

( v ) Preliminary Specifications

( ) Final Specifications

<b>Module</b>	15 Inch Color TFT-LCD
<b>Model Name</b>	G150XG01 V3

<b>Customer</b>	<b>Date</b>
_____	_____
<b>Checked &amp; Approved by</b>	
_____	_____
<p>Note: This Specification is subject to change without notice.</p>	

<b>Approved by</b>	<b>Date</b>
_____	_____
<b>Prepared by</b>	
_____	_____
<p>Audio-Video Business Unit / AU Optronics corporation</p>	

AUO Confidential For DATAMOL Internal Use Only 2010/8/27

**Contents**

<b>1. Operating Precautions</b> .....	<b>4</b>
<b>2. General Description</b> .....	<b>5</b>
2.1 Display Characteristics.....	5
2.2 Optical Characteristics .....	6
<b>3. Functional Block Diagram</b> .....	<b>9</b>
<b>4. Absolute Maximum Ratings</b> .....	<b>10</b>
4.1 Absolute Ratings of TFT LCD Module .....	10
4.2 Absolute Ratings of Environment .....	10
<b>5. Electrical Characteristics</b> .....	<b>11</b>
5.1 TFT LCD Module .....	11
5.2 Backlight Unit.....	13
<b>6. Signal Characteristic</b> .....	<b>14</b>
6.1 Pixel Format Image .....	14
6.2 Scanning Direction.....	14
6.3 Signal Description .....	15
6.4 The Input Data Format .....	16
6.5 Interface Timing.....	18
6.6 Power ON/OFF Sequence .....	19
<b>7. Connector &amp; Pin Assignment</b> .....	<b>20</b>
7.1 TFT-LCD Signal: LVDS Interface Connector.....	20
7.2 LED Backlight Unit: LED Driver Connector.....	22
7.3 LED Driver Connector Pin Assignment .....	22
<b>8. Reliability Test Criteria</b> .....	<b>23</b>
<b>9. Mechanical Characteristics</b> .....	<b>24</b>
9.1 LCM Outline Dimension (Front View).....	24
9.2 LCM Outline Dimension (Rear View).....	25
<b>10. Label and Packaging</b> .....	<b>26</b>
10.1 Shipping Label (on the rear side of TFT-LCD display).....	26
10.2 Carton Package .....	26
<b>11 Safety</b> .....	<b>27</b>
11.1 Sharp Edge Requirements.....	27
11.2 Materials .....	27
11.3 Capacitors.....	27
11.4 National Test Lab Requirement.....	27

**Record of Revision**

Version and Date	Page	Old description	New Description																																
rev2.0 2010/8/3	5	Typical Power Consumption: TBD	Typical Power Consumption: 9.63W																																
	6	R, G, B, W Color Coordinate: TBD	<table border="1"> <tr> <td>Red x</td> <td>0.577</td> <td>0.627</td> <td>0.677</td> </tr> <tr> <td>Red y</td> <td>0.298</td> <td>0.348</td> <td>0.398</td> </tr> <tr> <td>Green x</td> <td>0.288</td> <td>0.338</td> <td>0.388</td> </tr> <tr> <td>Green y</td> <td>0.539</td> <td>0.589</td> <td>0.639</td> </tr> <tr> <td>Blue x</td> <td>0.100</td> <td>0.150</td> <td>0.200</td> </tr> <tr> <td>Blue y</td> <td>0.029</td> <td>0.079</td> <td>0.129</td> </tr> <tr> <td>White x</td> <td>0.263</td> <td>0.313</td> <td>0.363</td> </tr> <tr> <td>White y</td> <td>0.279</td> <td>0.329</td> <td>0.379</td> </tr> </table>	Red x	0.577	0.627	0.677	Red y	0.298	0.348	0.398	Green x	0.288	0.338	0.388	Green y	0.539	0.589	0.639	Blue x	0.100	0.150	0.200	Blue y	0.029	0.079	0.129	White x	0.263	0.313	0.363	White y	0.279	0.329	0.379
Red x	0.577	0.627	0.677																																
Red y	0.298	0.348	0.398																																
Green x	0.288	0.338	0.388																																
Green y	0.539	0.589	0.639																																
Blue x	0.100	0.150	0.200																																
Blue y	0.029	0.079	0.129																																
White x	0.263	0.313	0.363																																
White y	0.279	0.329	0.379																																
	11	IDD & PDD: TBD	IDD: Typ.=700mA, Max.=840mA PDD: Typ.=2.31W, Max.=2.77W																																
	13	IVCC, PLED, IRUSH: TBD	IVCC: Typ.=0.61A PLED: Typ.=7.32W, Max.=10W IRUSH: Max.=1.5A																																
	13		Remove "LED Forward Current" and "LED Power"																																
	16	For 6Bits LVDS input MSB: R5 ; LSB: R0 MSB: G5 ; LSB: G0 MSB: B5 ; LSB: B0	For 6Bits LVDS input MSB: R7 ; LSB: R2 MSB: G7 ; LSB: G2 MSB: B7 ; LSB: B2																																

AUO Confidential For DATAMODUL Internal Use Only / 2010/8/21

## 1. Operating Precautions

- 1) Since front polarizer is easily damaged, please be cautious and not to scratch it.
- 2) Be sure to turn off power supply when inserting or disconnecting from input connector.
- 3) Wipe off water drop immediately. Long contact with water may cause discoloration or spots.
- 4) When the panel surface is soiled, wipe it with absorbent cotton or soft cloth.
- 5) Since the panel is made of glass, it may be broken or cracked if dropped or bumped on hard surface.
- 6) Since CMOS LSI is used in this module, take care of static electricity and insure human earth when handling.
- 7) Do not open nor modify the module assembly.
- 8) Do not press the reflector sheet at the back of the module to any direction.
- 9) In case if a module has to be put back into the packing container slot after it was taken out from the container, do not press the center of the LED Reflector edge. Instead, press at the far ends of the LED Reflector edge softly. Otherwise the TFT Module may be damaged.
- 10) At the insertion or removal of the Signal Interface Connector, be sure not to rotate nor tilt the Interface Connector of the TFT Module.
- 11) TFT-LCD Module is not allowed to be twisted & bent even force is added on module in a very short time. Please design your display product well to avoid external force applying to module by end-user directly.
- 12) Small amount of materials without flammability grade are used in the TFT-LCD module. The TFT-LCD module should be supplied by power complied with requirements of Limited Power Source (IEC60950 or UL1950), or be applied exemption.
- 13) Severe temperature condition may result in different luminance, response time.
- 14) Continuous operating TFT-LCD Module under high temperature environment may accelerate LED light bar exhaustion and reduce luminance dramatically.
- 15) The data on this specification sheet is applicable when TFT-LCD module is placed in landscape position.
- 16) Continuous displaying fixed pattern may induce image sticking. It's recommended to use screen saver or moving content periodically if fixed pattern is displayed on the screen.

## 2. General Description

G150XG01 V3 is a Color Active Matrix Liquid Crystal Display composed of a TFT-LCD display, a driver circuit, and a backlight system. The screen format is intended to support XGA (1024(H) x 768(V)) screen and 16.2M (RGB 8-bits) or 262k colors (RGB 6-bits). All input signals are LVDS interface compatible. All design rules of this module can correspond to PSWG standard.

G150XG01 V3 is designed for industrial display applications.

### 2.1 Display Characteristics

The following items are characteristics summary on the table under 25 °C condition:

Items	Unit	Specifications
Screen Diagonal	[inch]	15
Active Area	[mm]	304.128(H) x 228.096(V)
Pixels H x V		1024x2, 768x2 (RGBW)
Pixel Pitch	[mm]	0.297 x 0.297
Pixel Arrangement		R.G.B.W. Rectangle
Display Mode		TN, Normally White
Nominal Input Voltage VDD	[Volt]	3.3 typ.
Typical Power Consumption	[Watt]	9.63 ( 64 Gray Bar pattern)
Weight	[Grams]	1000g (max.)
Physical Size	[mm]	326.5(H)x 253.5(V) x 13.1(D) (max.)
Electrical Interface		1 channel LVDS
Surface Treatment		Anti-glare, Hardness 3H
Support Color		16.2M / 262K colors
Temperature Range Operating Storage (Non-Operating)	[°C] [°C]	-30 to +85 -30 to +85
RoHS Compliance		RoHS Compliance

AUO Confidential For DATAMODUL Internal Use Only / 2010/8/27

## 2.2 Optical Characteristics

The optical characteristics are measured under stable conditions at 25°C (Room Temperature):

Item	Unit	Conditions	Min.	Typ.	Max.	Note
White Luminance	[cd/m <sup>2</sup> ]	100% Dimming (center point)	320	400	-	1
Uniformity	%	9 Points	75	80	-	1, 2, 3
Contrast Ratio			400	700	-	4
Cross talk	%					
Response Time	[msec]	Rising	-	5.7		6
	[msec]	Falling	-	2.3		
	[msec]	Raising + Falling	-	8		
Viewing Angle	[degree] [degree]	Horizontal (Right) CR = 10 (Left)	70 70	80 80	- -	7
	[degree] [degree]	Vertical (Upper) CR = 10 (Lower)	50 70	60 80	- -	
Color / Chromaticity Coordinates (CIE 1931)		Red x	0.577	0.627	0.677	
		Red y	0.298	0.348	0.398	
		Green x	0.288	0.338	0.388	
		Green y	0.539	0.589	0.639	
		Blue x	0.100	0.150	0.200	
		Blue y	0.029	0.079	0.129	
		White x	0.263	0.313	0.363	
		White y	0.279	0.329	0.379	
Color Gamut	%		-	60	-	

Note 1: Measurement method

Equipment Pattern Generator, Power Supply, Digital Voltmeter, Luminance meter (SR\_3 or equivalent)

Aperture 1" with 50cm viewing distance

Test Point Center

Environment < 1 lux

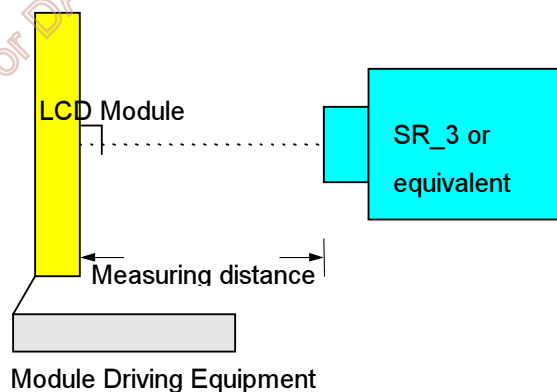

Note 2: Definition of 9 points position (Display active area : 304.128(H) x 228.096(V))

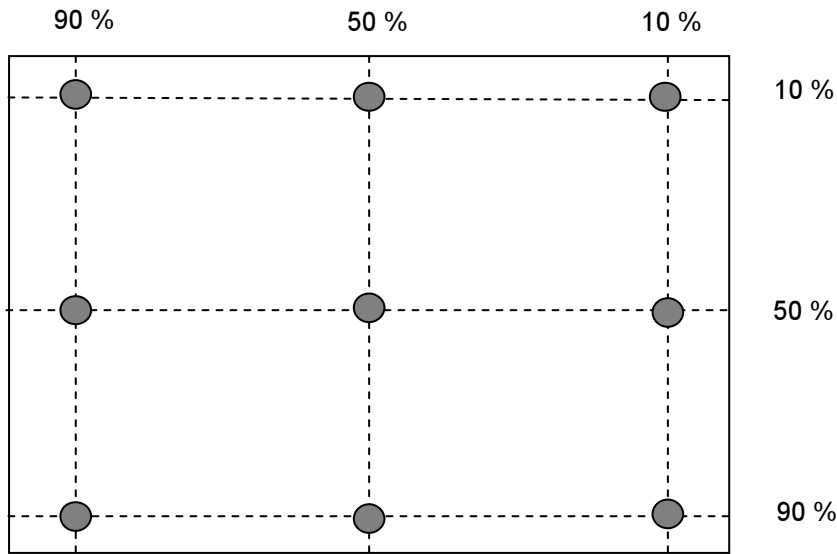

Note 3: The luminance uniformity of 9 points is defined by dividing the minimum luminance values by the maximum test point luminance

$$\delta_{w9} = \frac{\text{Minimum Brightness of nine points}}{\text{Maximum Brightness of nine points}}$$

Note 4 : Definition of contrast ratio (CR):

$$\text{Contrast ratio (CR)} = \frac{\text{Brightness on the "White" state}}{\text{Brightness on the "Black" state}}$$

Note 5 : Definition of cross talk (CT)

$$CT = | YB - YA | / YA \times 100 (\%)$$

Where

YA = Luminance of measured location without gray level 0 pattern (cd/m2)

YB = Luminance of measured location with gray level 0 pattern (cd/m2)

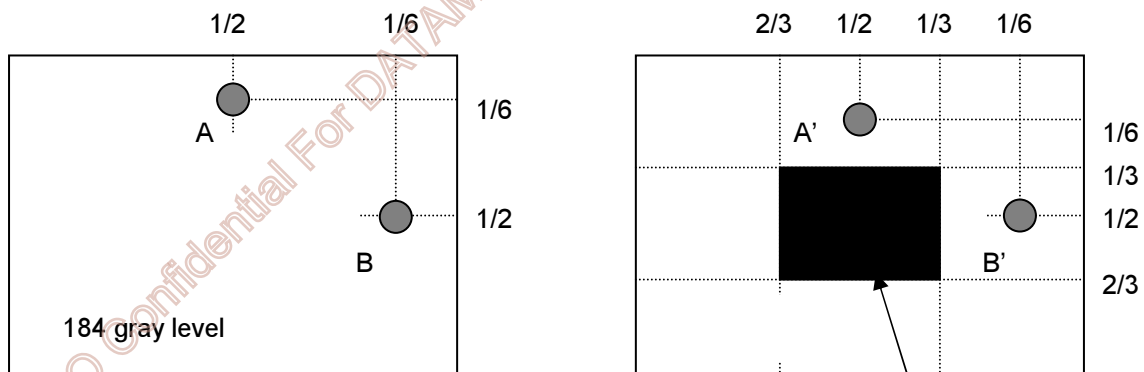

Note 6: Definition of response time:

The output signals of photo detector are measured when the input signals are changed from “White” to “Black” (falling time) and from “Black” to “White” (rising time), respectively. The response time interval is between 10% and 90% of amplitudes. Please refer to the figure as below.

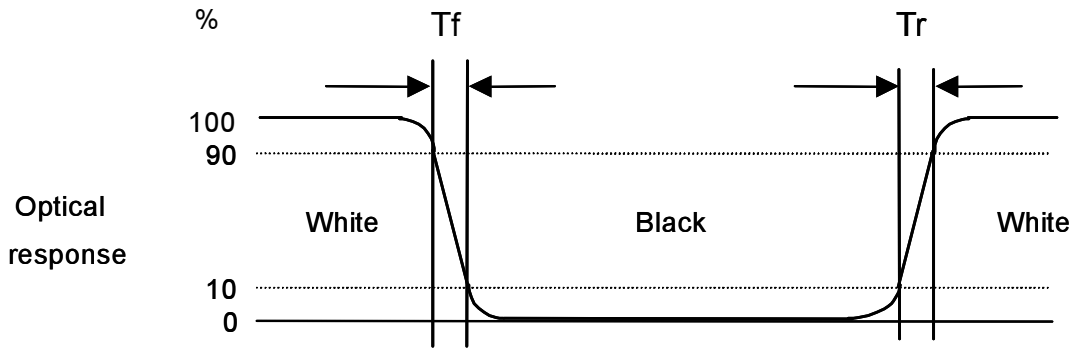

Note 7: Definition of viewing angle

Viewing angle is the measurement of contrast ratio  $\geq 10$ , at the screen center, over a 180° horizontal and 180° vertical range (off-normal viewing angles). The 180° viewing angle range is broken down as below: 90° ( $\theta$ ) horizontal left and right, and 90° ( $\phi$ ) vertical high (up) and low (down). The measurement direction is typically perpendicular to the display surface with the screen rotated to its center to develop the desired measurement viewing angle.

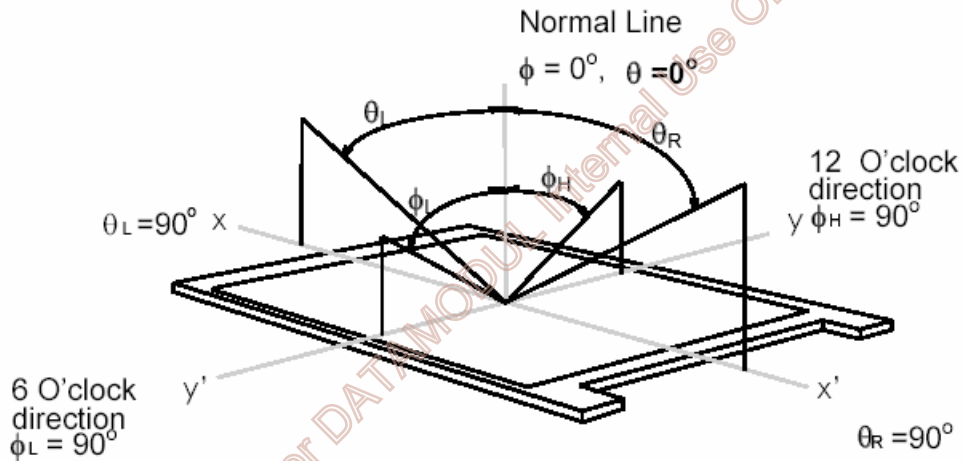

AUO Confidential For DATAMOBILE Internal Use Only / 2010/01/27

### 3. Functional Block Diagram

The following diagram shows the functional block of the 15 inch color TFT/LCD module:

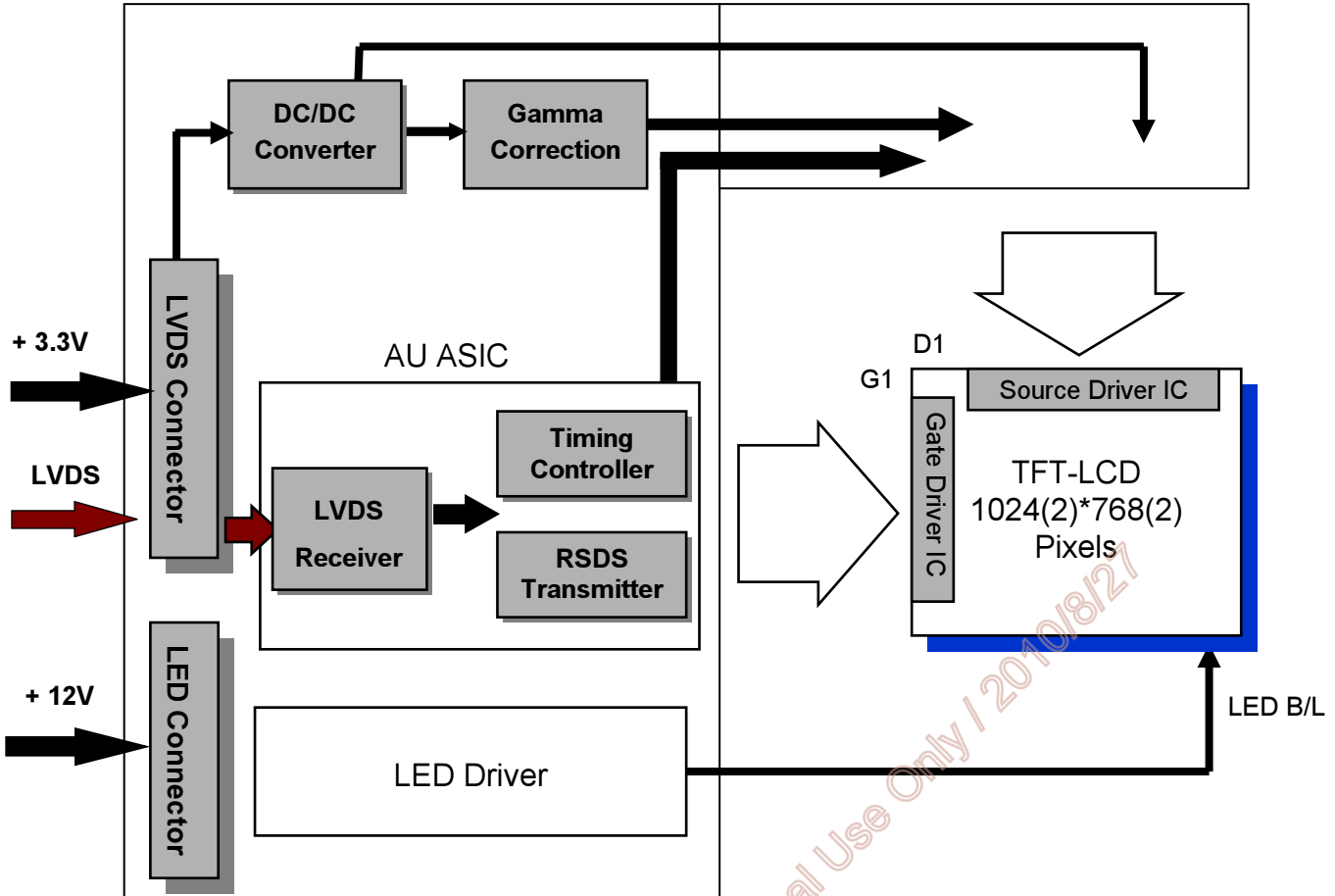

AUO Confidential For DATAMODUL Internal Use Only / 2010/8/21

## 4. Absolute Maximum Ratings

### 4.1 Absolute Ratings of TFT LCD Module

Item	Symbol	Min	Max	Unit
Logic/LCD Drive Voltage	Vin	- 0.3	+3.6	[Volt]

### 4.2 Absolute Ratings of Environment

Item	Symbol	Min	Max	Unit
Operating Temperature	TOP	-30	+85	[°C]
Operation Humidity	HOP	8	90	[%RH]
Storage Temperature	TST	-30	+85	[°C]
Storage Humidity	HST	8	90	[%RH]

Note: Maximum Wet-Bulb should be 39°C and no condensation.

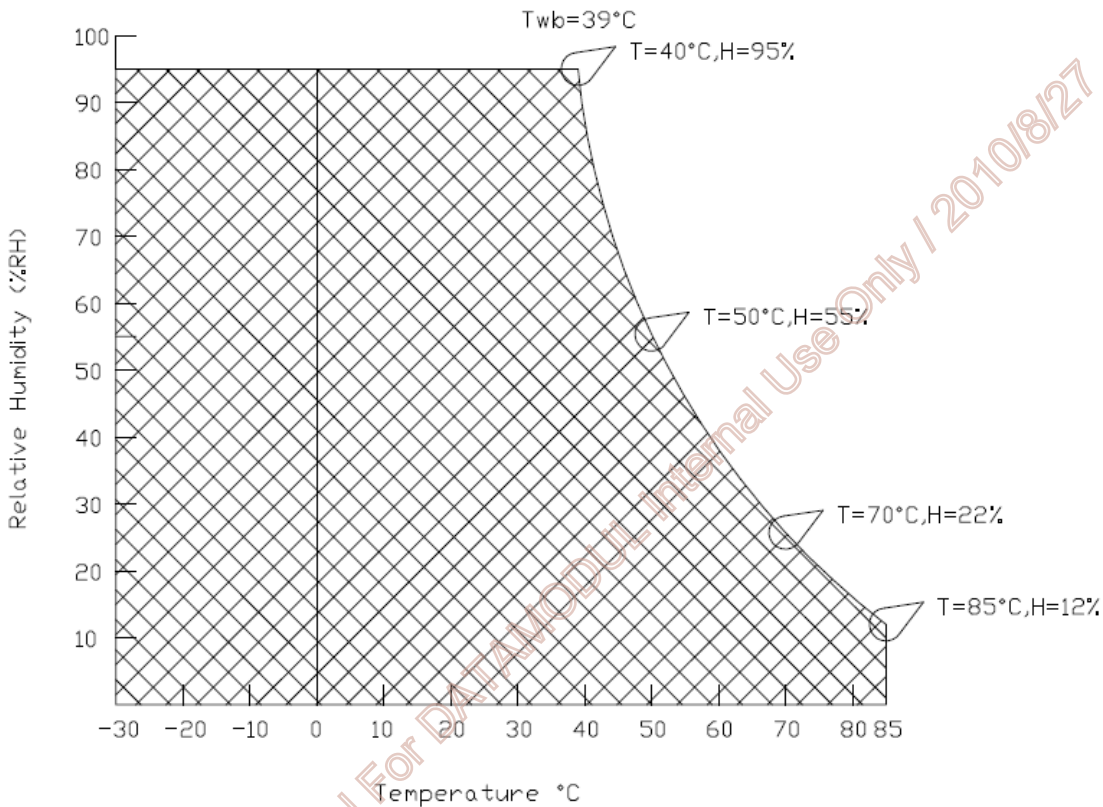

## 5. Electrical Characteristics

### 5.1 TFT LCD Module

#### 5.1.1 Power Specification

Symbol	Parameter	Min	Typ	Max	Units	Remark
VDD	Logic/LCD Drive Voltage	3.0	3.3	3.6	[Volt]	± 10%
IDD	VDD Current	-	700	840	[mA]	64 Gray Bar Pattern (VDD=3.3V, at 60Hz)
Irush	LCD Inrush Current	-	-	3	[A]	Note 1
PDD	VDD Power	-	2.31	2.77	[Watt]	64 Gray Bar Pattern (VDD=3.3V, at 60Hz)

Note 1: Measurement condition:

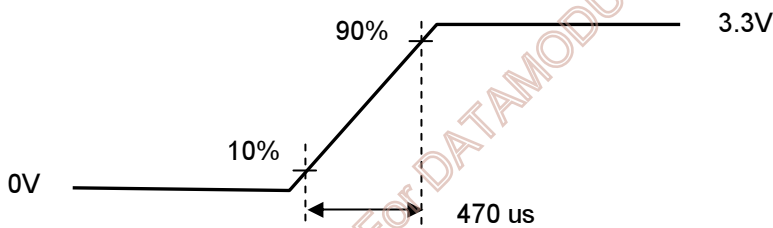
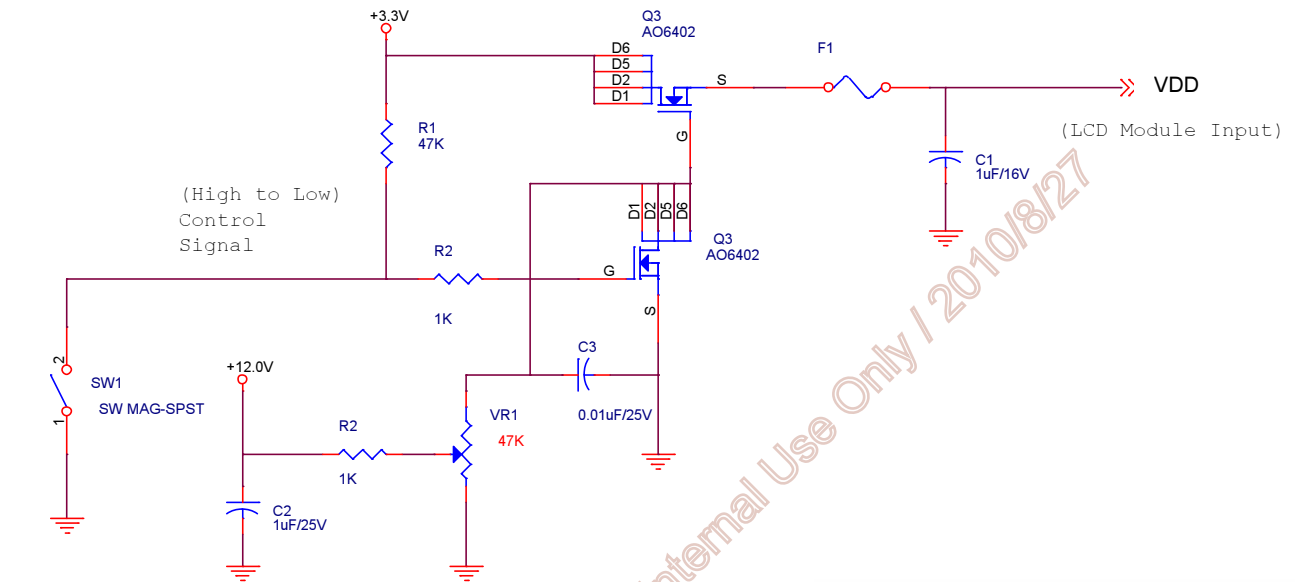

VDD rising time



64 Gray pattern

AUO Confidential For DATAMODUL Internal Use Only / 2010/8/27

### 5.1.2 Signal Electrical Characteristics

Input signals shall be low or Hi-Z state when VDD is off.

Symbol	Item	Min.	Typ.	Max.	Unit	Remark
VTH	Differential Input High Threshold	-	-	100	[mV]	VCM=1.2V
VTL	Differential Input Low Threshold	100	-	-	[mV]	VCM=1.2V
VID	Input Differential Voltage	100	400	600	[mV]	
VICM	Differential Input Common Mode Voltage	1.15	1.2	1.45	[V]	VTH/VTL=±100mV

Note: LVDS Signal Waveform.

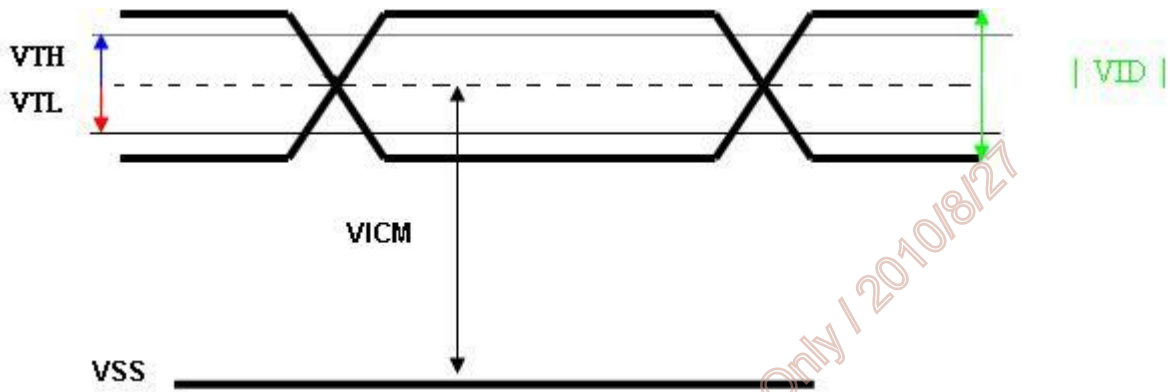

AUO Confidential For DATAMODUL Internal Use Only / 2010/8/27

## 5.2 Backlight Unit

### 5.2.1 Parameter guideline for LED

Following characteristics are measured under stable condition using a LED driving board at 25°C (Room Temperature).

Symbol	Parameter	Min	Typ	Max	Unit	Remark
V <sub>cc</sub>	Input Voltage	10.8	12	12.6	Volt	
I <sub>vcc</sub>	Input Current	-	0.61	-	A	100% Dimming
P <sub>LED</sub>	Power Consumption	-	7.32	10	Watt	100% Dimming
I <sub>rush</sub>	Inrush Current	-	-	1.5	A	
F <sub>PWM</sub>	PWM Dimming Frequency	200	-	20k	Hz	
	Swing Voltage	4.5	5	5.5		
	Dimming Duty Cycle	5	-	100	%	
V <sub>analog</sub>	Analog Dimming Voltage	2.0	5	5.5		5V, 100% Brightness
I <sub>F</sub>	LED Forward Current	-	80	84	mA	T <sub>a</sub> = 25°C
Operating Life		50000	-	-	Hrs	T <sub>a</sub> = 25°C

Note 1: T<sub>a</sub> means ambient temperature of TFT-LCD module.

Note 2: If G150XG01 V3 module is driven at high ambient temperature & humidity condition. The operating life will be reduced.

Note 3: Operating life means brightness goes down to 50% initial brightness. Min. operating life time is estimated data.

AUO Confidential For DATAMODUL Internal Use Only / 2010/8/27

## 6. Signal Characteristic

### 6.1 Pixel Format Image

Following figure shows the relationship between input signal and LCD pixel format.

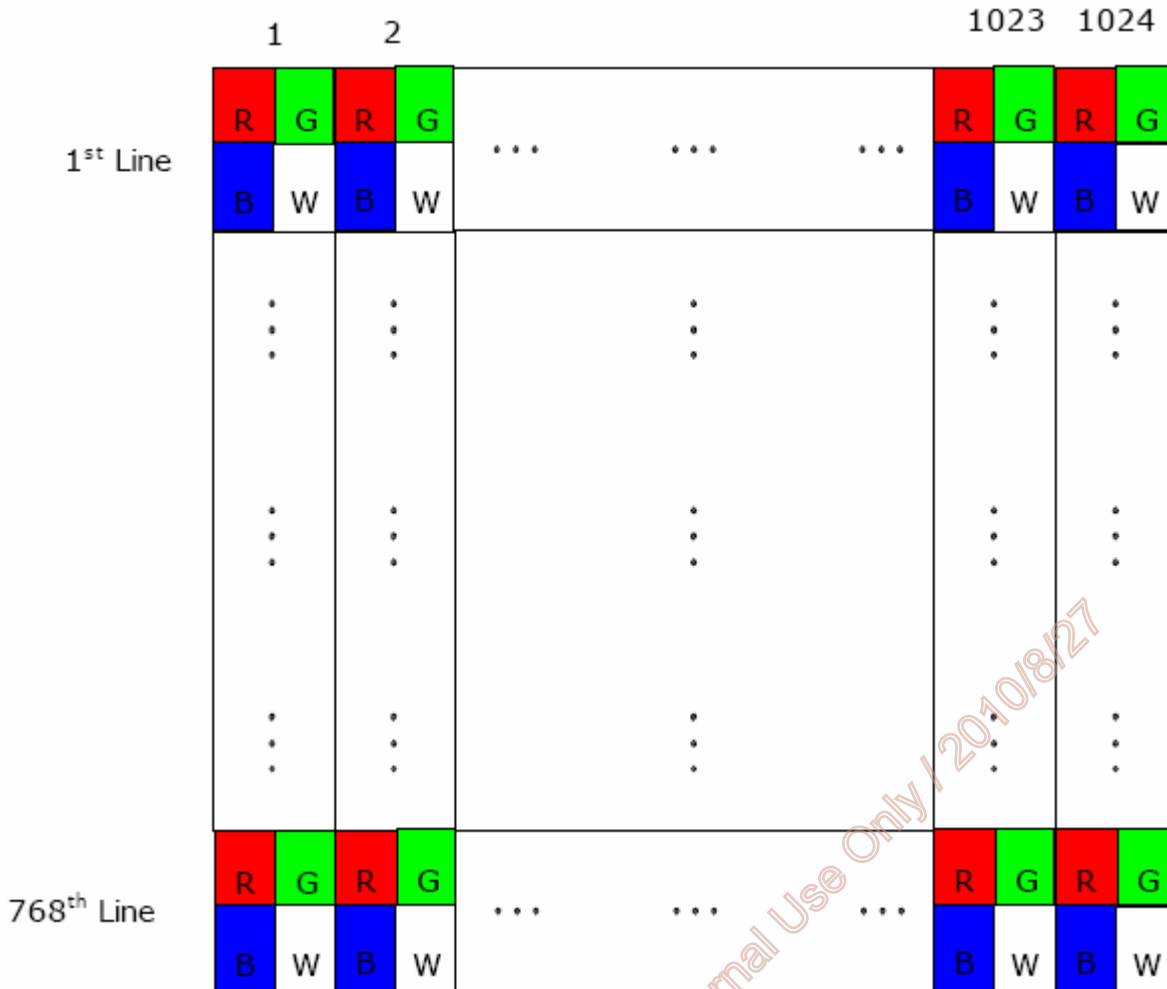

### 6.2 Scanning Direction

The following figures show the image seen from the front view. The arrow indicates the direction of scan.

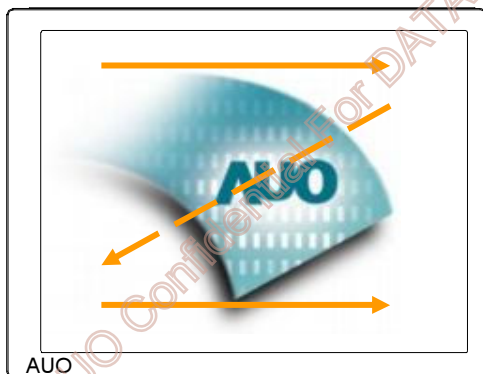

Fig. 1 Normal scan (Pin4, REV = Low or NC)

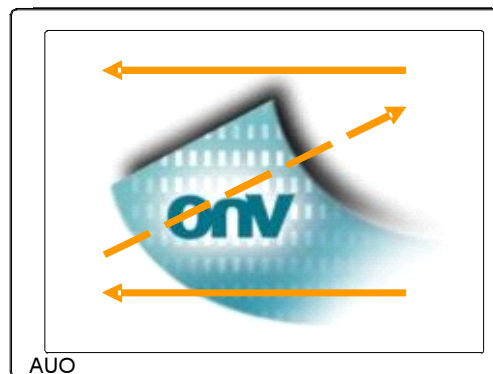

Fig. 2 Reverse scan (Pin4, REV = High)

### 6.3 Signal Description

The module using a pair of LVDS receiver SN75LVDS82(Texas Instruments) or compatible. LVDS is a differential signal technology for LCD interface and high speed data transfer device. Transmitter shall be SN75LVDS83(negative edge sampling) or compatible. The first LVDS port(RxOxxx) transmits odd pixels while the second LVDS port(RxExxx) transmits even pixels.

Input Signal Interface		
Pin No.	Symbol	Description
1	VDD	Power Supply, 3.3V (typical)
2	VDD	Power Supply, 3.3V (typical)
3	GND	Ground
4	REV	Reverse Scan [H: Enable; L/NC: Disable]*Note1
5	Rin0-	- LVDS differential data input
6	Rin0+	+ LVDS differential data input
7	GND	Ground
8	Rin1-	- LVDS differential data input
9	Rin1+	+ LVDS differential data input
10	GND	Ground
11	Rin2-	- LVDS differential data input
12	Rin2+	+ LVDS differential data input
13	GND	Ground
14	ClkIN-	- LVDS differential clock input
15	ClkIN+	+ LVDS differential clock input
16	GND	Ground
17	Rin3-	- LVDS differential data input *Note2
18	Rin3+	+ LVDS differential data input *Note2
19	NC/GND	Reserved for AUO internal test. Please set it as NC or Ground.
20	SEL68	Selection for 6 bits/8bits LVDS data input[H/NC: 6bits, L: 8bits]*Note1

Note 1: Input signals shall be in low status when VDD is off.

Note 2: For 6bits input mode, pin 17 and pin 18 must be floated.

Note 3: High stands for “3.3V”, Low stands for “0V”, NC stands for “No Connection”.

AUO Confidential For Internal Use Only / 2010/8/27

## 6.4 The Input Data Format

### 6.4.1 SEL68

SEL68 = "High" or "NC" for 6 bits LVDS Input

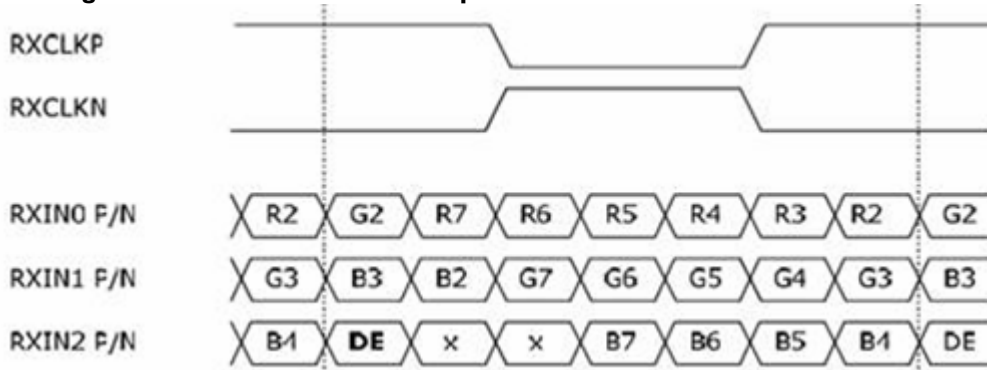

SEL68 = "Low" for 8 bits LVDS Input

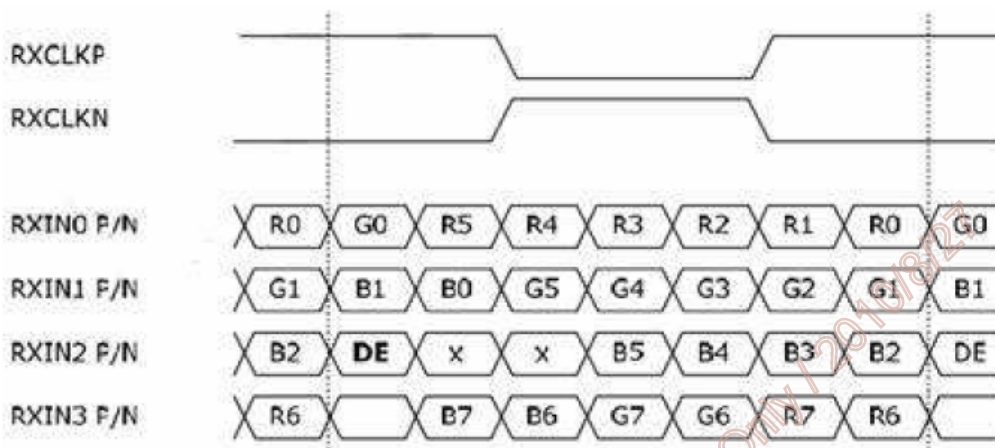

Signal Name	Description	Remark
R7	Red Data 7	Red-pixel Data  For 8Bits LVDS input MSB: R7 ; LSB: R0
R6	Red Data 6	
R5	Red Data 5	
R4	Red Data 4	
R3	Red Data 3	
R2	Red Data 2	
R1	Red Data 1	
R0	Red Data 0	
G7	Green Data 7	Green-pixel Data  For 8Bits LVDS input MSB: G7 ; LSB: G0
G6	Green Data 6	
G5	Green Data 5	
G4	Green Data 4	
G3	Green Data 3	
G2	Green Data 2	
G1	Green Data 1	
G0	Green Data 0	
B7	Blue Data 7	Blue-pixel Data  For 8Bits LVDS input MSB: B7 ; LSB: B0
B6	Blue Data 6	
B5	Blue Data 5	
B4	Blue Data 4	
B3	Blue Data 3	
B2	Blue Data 2	
B1	Blue Data 1	
B0	Blue Data 0	

RxCLKIN	LVDS Data Clock	The typical frequency is 65MHz. The signal is used to strobe the pixel data and DE signals. All pixel data shall be valid at the falling edge when the DE signal is high.
DE	Data Enable Signal	When the signal is high, the pixel data shall be valid to be displayed.

Note: Output signals from any system shall be low or Hi-Z state when VDD is off.

AUO Confidential For DATAMODUL Internal Use Only / 2010/8/27

## 6.5 Interface Timing

### 6.5.1 Timing Characteristics

Signal	Parameter	Symbol	Min.	Typ.	Max.	Unit	
Clock Timing	Clock frequency	$1/T_{Clock}$	50	65	80	MHz	
Vsync Timing	Vertical Section	Period	$T_V$	776	806	1023	$T_{Line}$
		Active	$T_{VD}$	-	768	-	
		Blanking	$T_{VB}$	8	38	255	
Hsync Timing	Horizontal Section	Period	$T_H$	1054	1344	2047	$T_{Clock}$
		Active	$T_{HD}$	-	1024	-	
		Blanking	$T_{HB}$	40	320	1023	

Note: DE mode only.

Note : Typical value refer to VESA STANDARD

### 6.5.2 Input Timing Diagram

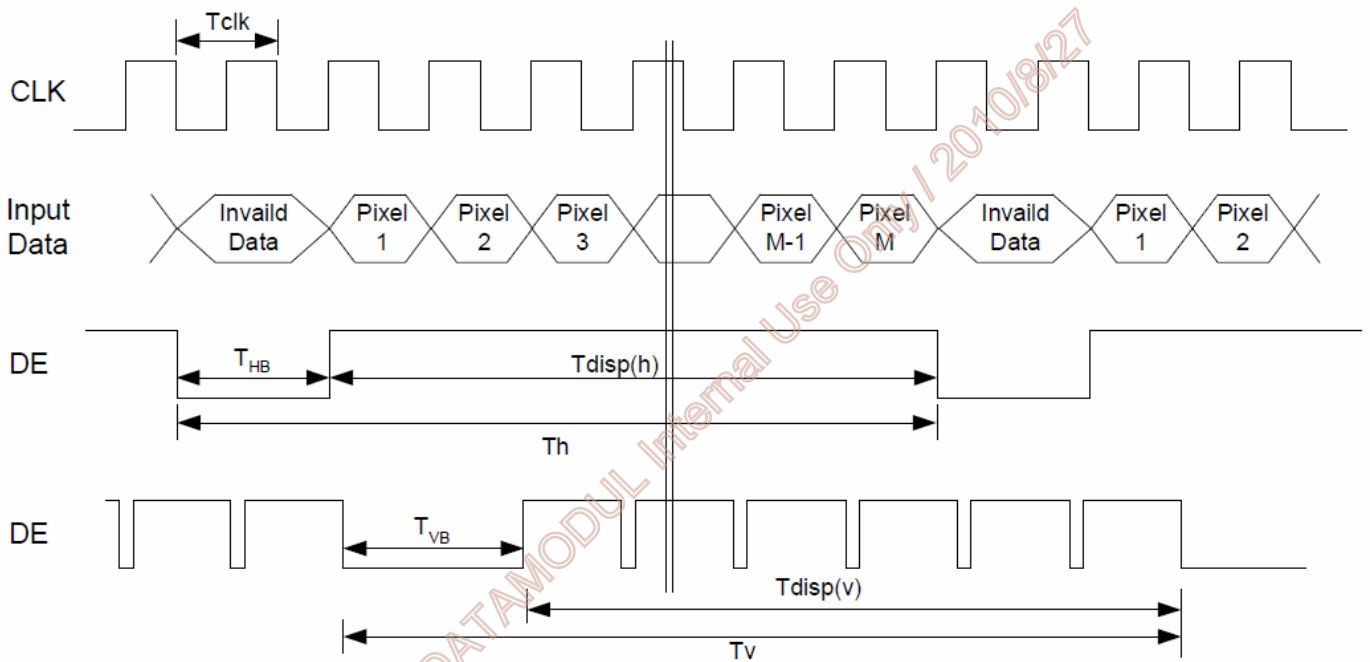

## 6.6 Power ON/OFF Sequence

VDD power and LED on/off sequence is as below. Interface signals are also shown in the chart. Signals from any system shall be Hi-Z state or low level when VDD is off.

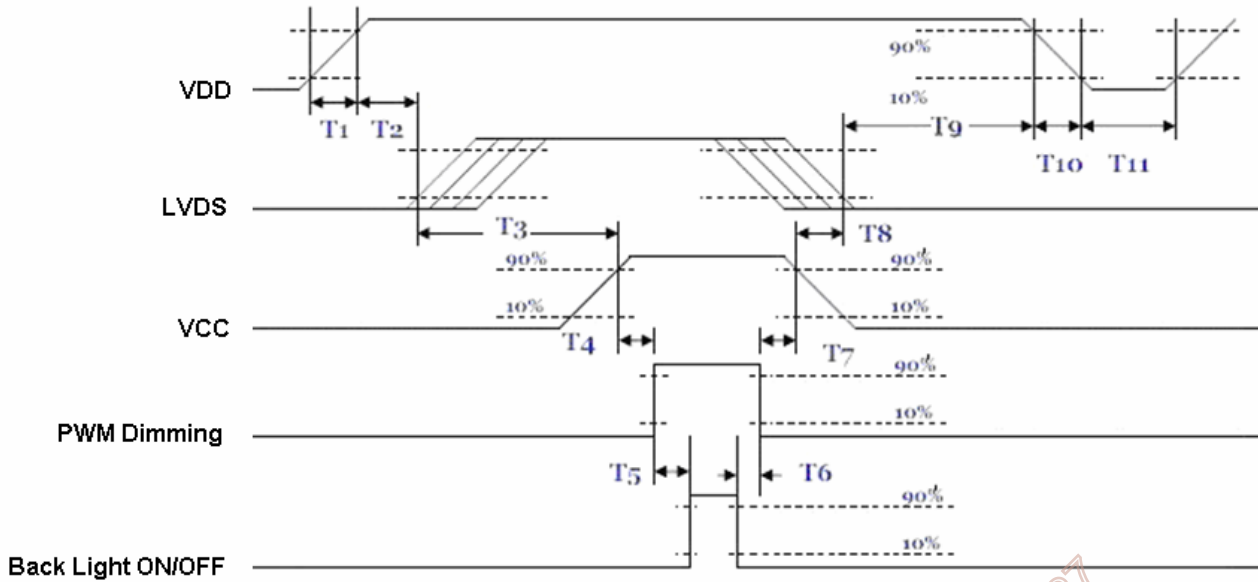

Power ON/OFF sequence timing

Parameter	Value			Units
	Min.	Typ.	Max.	
T1	0.5	-	10	[ms]
T2	30	40	50	[ms]
T3	200	-	-	[ms]
T4	10	-	-	[ms]
T5	10	-	-	[ms]
T6	0	-	-	[ms]
T7	10	-	-	[ms]
T8	100	-	-	[ms]
T9	0	16	50	[ms]
T10	-	-	10	[ms]
T11	1000	-	-	[ms]

The above on/off sequence should be applied to avoid abnormal function in the display. Please make sure to turn off the power when you plug the cable into the input connector or pull the cable out of the connector.

## 7. Connector & Pin Assignment

Physical interface is described as for the connector on module. These connectors are capable of accommodating the following signals and will be following components.

### 7.1 TFT-LCD Signal: LVDS Interface Connector

Connector Name / Designation	Signal Connector
Manufacturer	STM or compatible
Connector Model Number	MSB240420-E
Mating Housing Part Number	P240420 or compatible

Pin#	Signal Name	Pin#	Signal Name
1	VDD	2	VDD
3	GND	4	REV
5	Rin0-	6	Rin0+
7	GND	8	Rin1-
9	Rin1+	10	GND
11	Rin2-	12	Rin2+
13	GND	14	ClkIN-
15	ClkIN+	16	GND
17	Rin3-	18	Rin3+
19	NC/GND	20	SEL68

AUO Confidential For DATAMODUL Internal Use Only | 2010/8/27

## 7.1.1 Connector Illustration

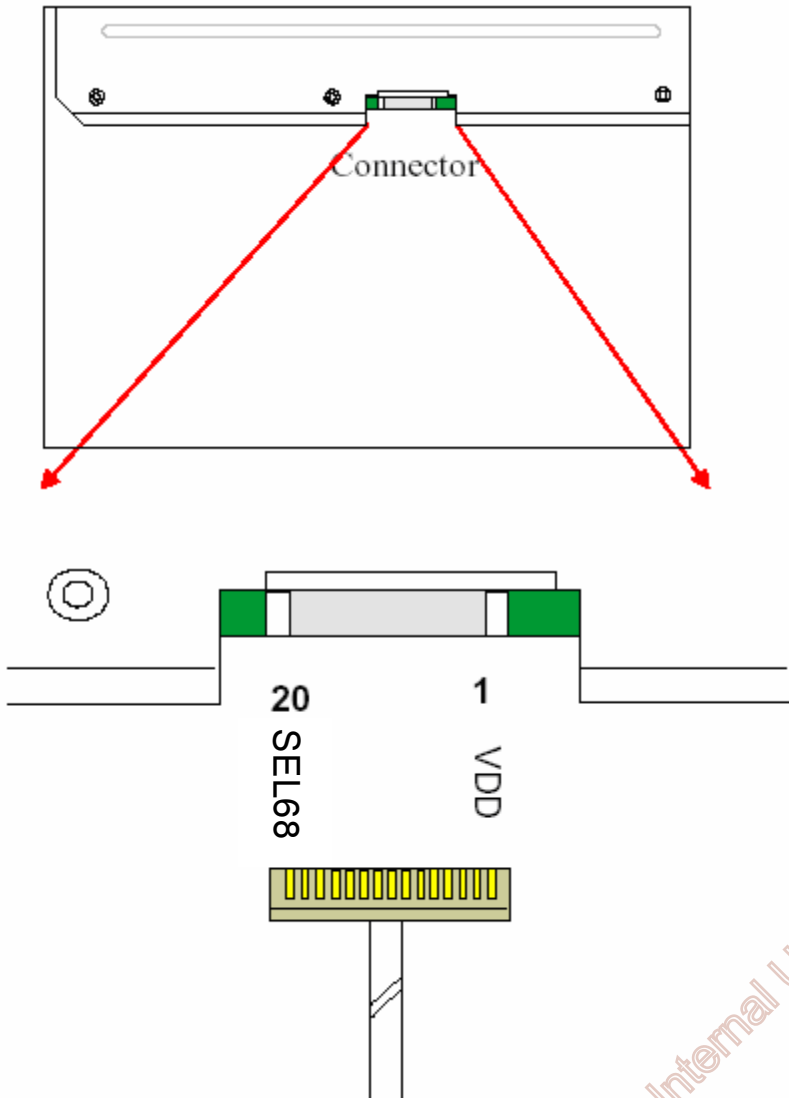

AUO Confidential For DATAMODUL Internal Use Only / 2010/8/27

## 7.2 LED Backlight Unit: LED Driver Connector

<b>Connector Name / Designation</b>	<b>LED Connector</b>
Manufacturer	E&T or compatible
Connector Model Number	3808K-F05N-02R or compatible
Mating Connector Model Number	H208K-P05N-02B or compatible

## 7.3 LED Driver Connector Pin Assignment

Pin#	Symbol	Signal Name
1	Vcc	12V
2	GND	GND
3	Enable	5V-On / 0V-Off
4	Dimming	PWM Dimming or Analog Dimming
5	NC	NC

AUO Confidential For DATAMODUL Internal Use Only / 2010/8/27

## 8. Reliability Test Criteria

Items	Required Condition	Note
Temperature Humidity Bias	50□/80%,300 hours	
High Temperature Operation	85□,300 hours	
Low Temperature Operation	-30□,300 hours	
Hot Storage	85□,300 hours	
Cold Storage	-30□,300 hours	
Thermal Shock Test	-20□/30 min ,60□/30 min ,100cycles	
Shock Test (Non-Operating)	50G,20ms,Half-sine wave,( ±X, ±Y, ±Z)	
Vibration Test (Non-Operating)	1.5G, (10~200Hz, P-P) 30 mins/axis (X, Y, Z)	
On/off test	On/10 sec, Off/10 sec, 30,000 cycles	
ESD	Contact Discharge: ± 8KV, 150pF(330Ω ) 1sec, 8 points, 25 times/ point Air Discharge: ± 15KV, 150pF(330Ω ) 1sec, 8 points, 25 times/ point	Note 1

Note1: According to EN61000-4-2, ESD class B: Some performance degradation allowed. No data lost  
 . Self-recoverable. No hardware failures.

AUO Confidential For DATAMODUL Internal Use Only / 2019/04/24

## 9. Mechanical Characteristics

### 9.1 LCM Outline Dimension (Front View)

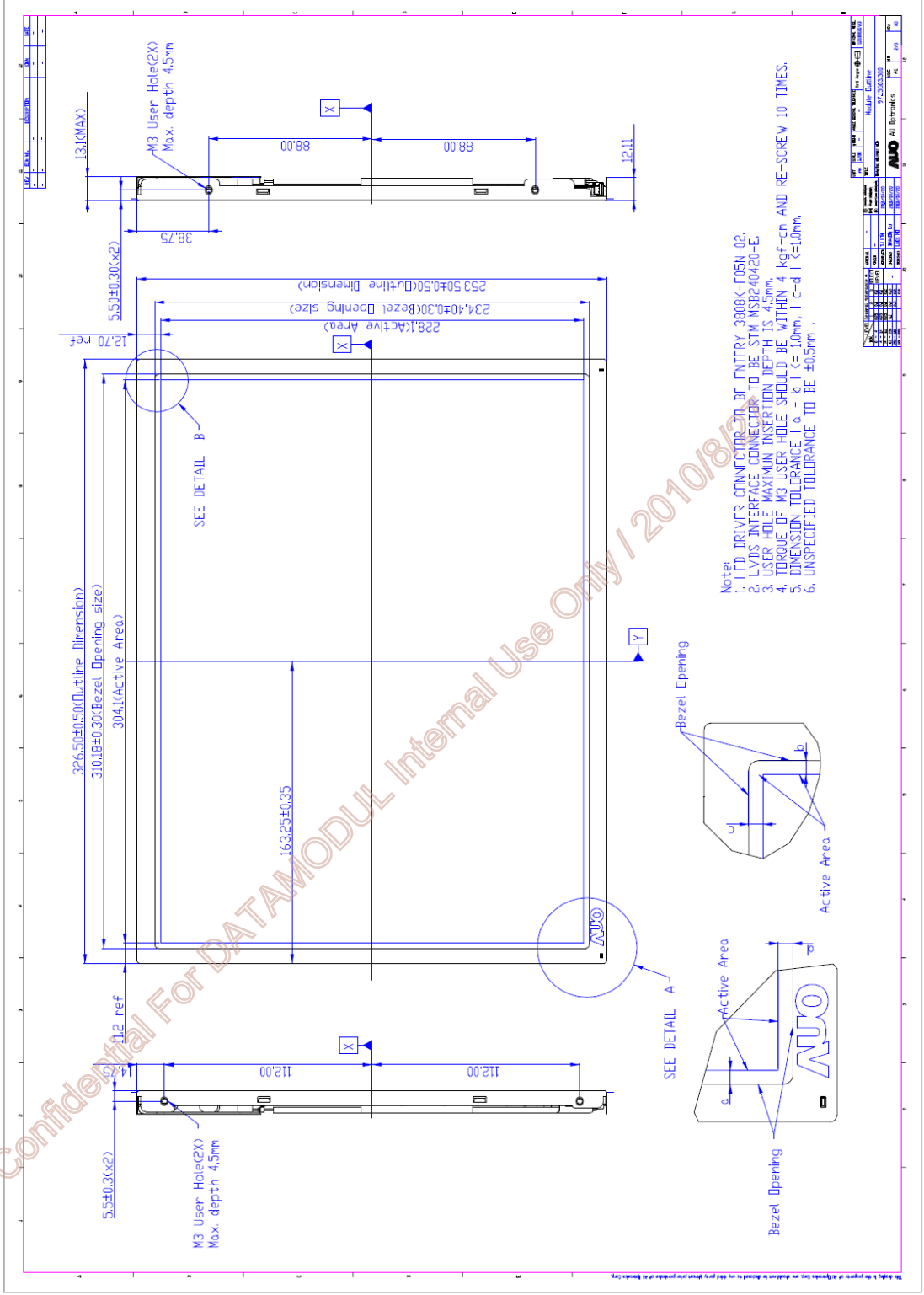

### 9.2 LCM Outline Dimension (Rear View)

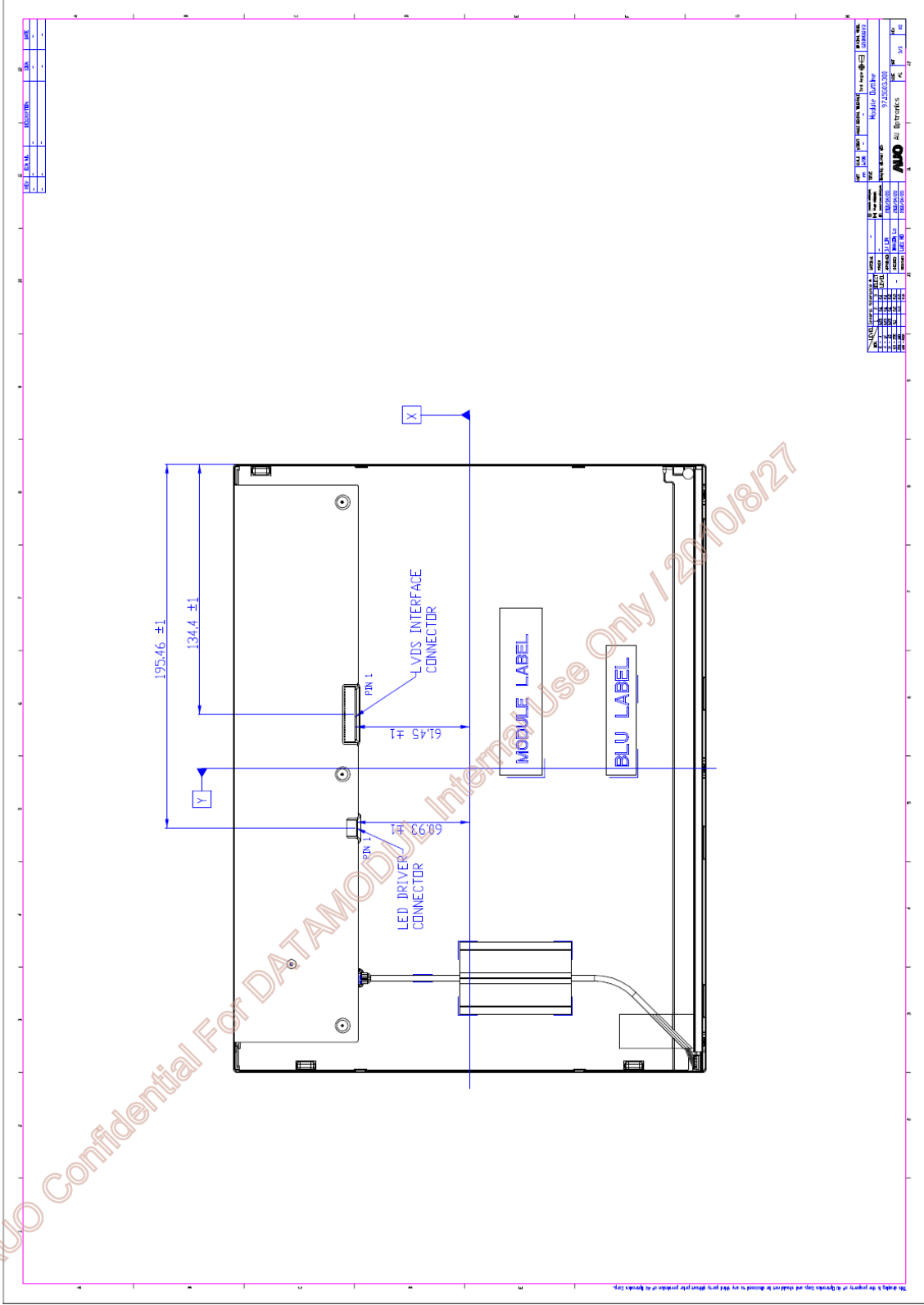

## 10. Label and Packaging

### 10.1 Shipping Label (on the rear side of TFT-LCD display)



### 10.2 Carton Package

- Max capacity: 15 TFT-LCD module per carton (12pcs \* 1 layers)
- Max weight: 20 kg per carton
- Outside dimension of carton: 375(L)mm\* 430(W)mm\* 353(H)mm

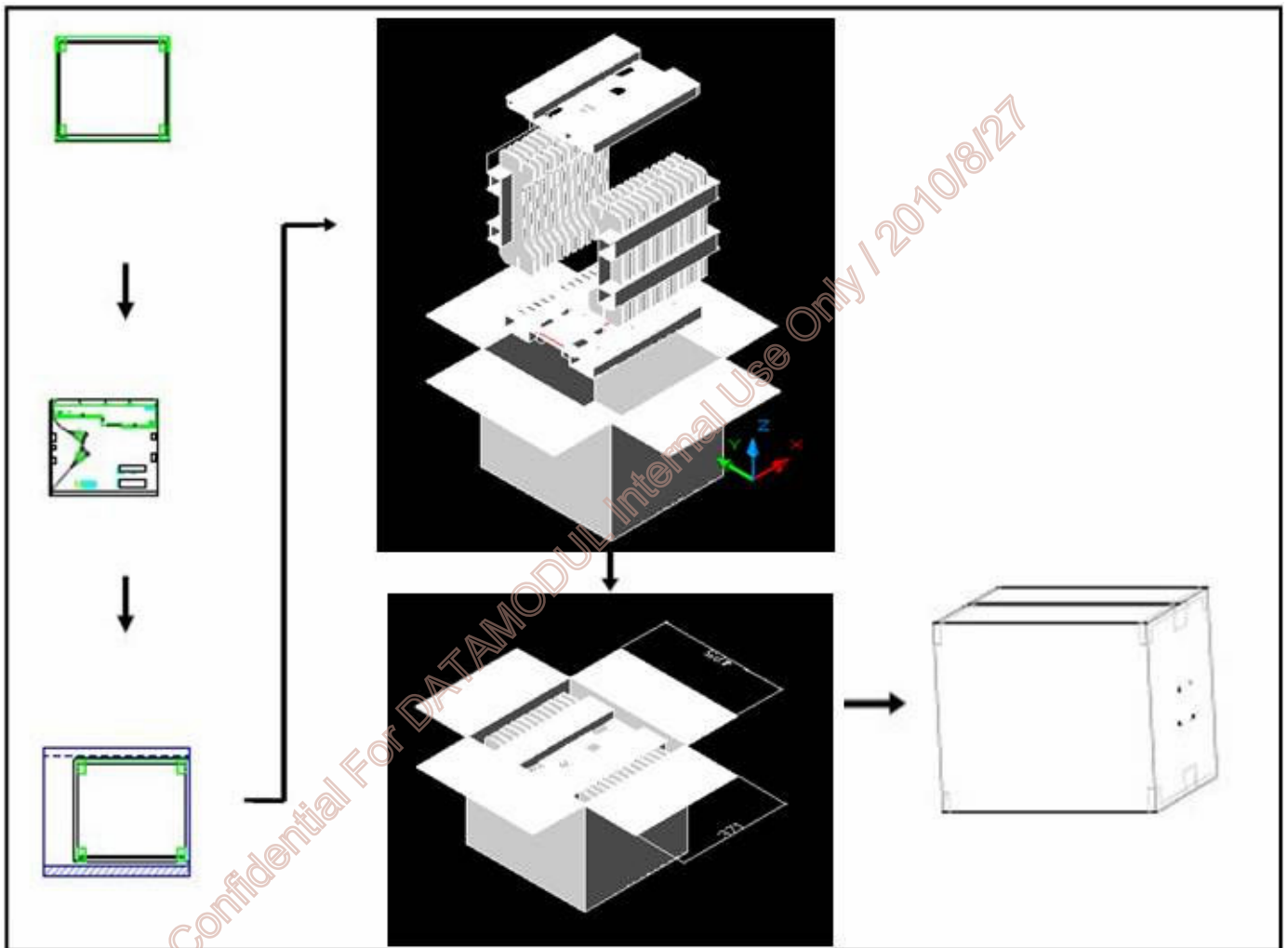

## 11 Safety

### 11.1 Sharp Edge Requirements

There will be no sharp edges or comers on the display assembly that could cause injury.

### 11.2 Materials

#### 11.2.1 Toxicity

There will be no carcinogenic materials used anywhere in the display module. If toxic materials are used, they will be reviewed and approved by the responsible AUO toxicologist.

#### 11.2.2 Flammability

All components including electrical components that do not meet the flammability grade UL94-V1 in the module will complete the flammability rating exception approval process.

The printed circuit board will be made from material rated 94-V1 or better. The actual UL flammability rating will be printed on the printed circuit board.

### 11.3 Capacitors

If any polarized capacitors are used in the display assembly, provisions will be made to keep them from being inserted backwards.

### 11.4 National Test Lab Requirement

The display module will satisfy all requirements for compliance to:

**UL 1950, First Edition**

**U.S.A. Information Technology Equipment**

AUO Confidential For DATAMODUL Internal Use Only / 2010/8/27