

REVISIONS			
REV	DESCRIPTION, ECN, EAR NO.	DATE	APP'D
D	ADD LED OPTIONS SHEET	JUL26/21	L.C.
E	REVISE DIM PER REAL SHELL	AUG26/24	K.T.

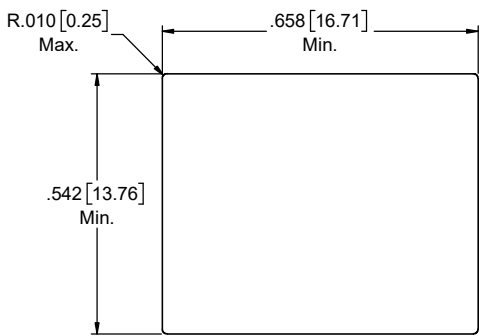

**RECOMMEND PANEL CUTOUT**

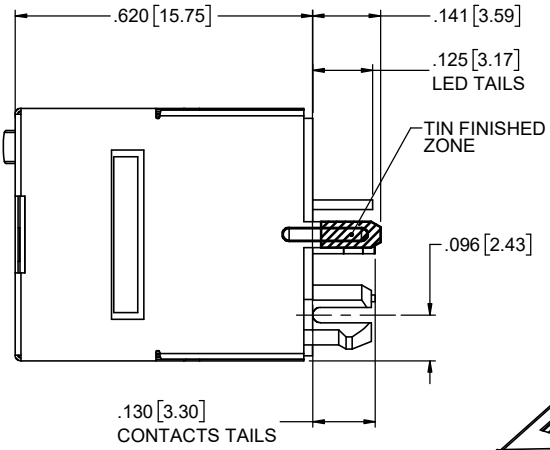
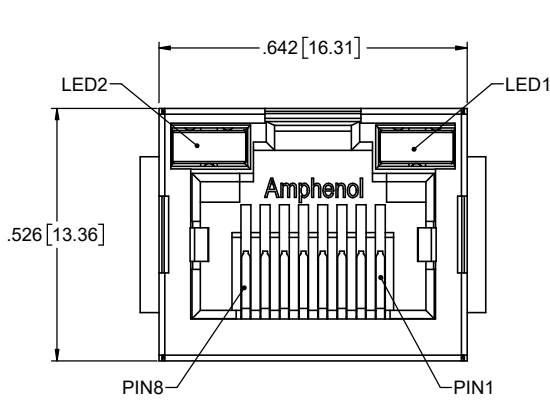
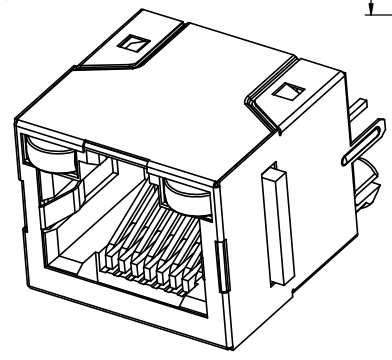
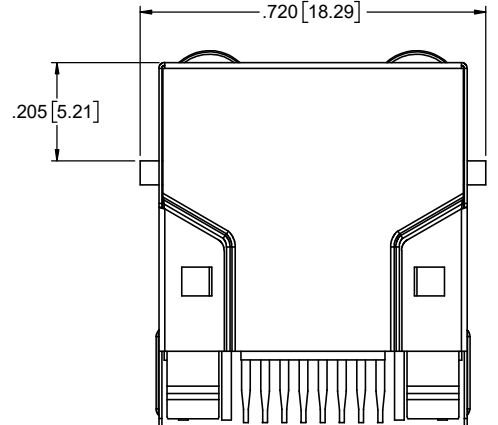

TYPE FOR SINGLE COLOR LED  
RED, GREEN OR YELLOW

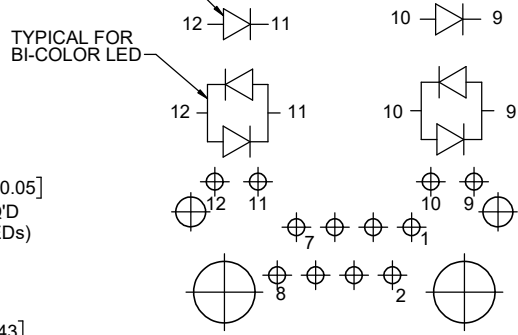

**NOTES:**

PLASTIC HOUSING: HIGH TEMPERATURE THERMOPLASTIC  
FLAMMABILITY RATING UL 94V-0, COLOR: BLACK

CONTACTS: PHOSPHOR BRONZE  
(FLAT) PLATING: 30µ" [0.76 MICRONS]  
MIN. GOLD ON MATING SURFACES.  
50µ" [1.27 MICRONS]  
MIN. NICKEL UNDERPLATE  
100µ" [2.54 MICRONS]  
MIN. MATTE TIN ON CONTACT TAILS.

SHIELD: STAINLESS STEEL WITH TIN FINISHED ON SOLDER TAILS.

PACKAGING: TRAY PACKAGING, 110PCS/TRAY, 1320PCS/CARTON

RECOMMENDED SOLDERING TEMPERATURE:  
WAVE SOLDERING TEMPERATURE AT 260 °C MAXIMUM  
FOR 5-8 SEC.

AMPHENOL PART NUMBER: RJHSE-338X-A1

REFER TO NEXT PAGE  
FOR LED ORDERING  
CODE

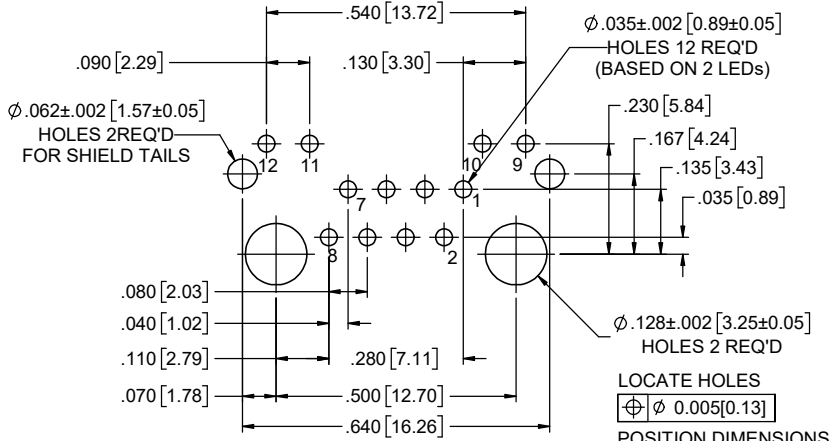

**RECOMMENDED P.C.B LAYOUT  
COMPONENT SIDE OF BOARD**

LOCATE HOLES  
⊕ ±0.005 [0.13]  
POSITION DIMENSIONS  
ARE BASIC



UNLESS SPECIFIED OTHERWISE		DRAWN	J.OUYANG	JUL04/06
PRIMARY UNITS	INCHES	CHECKED	L.CHAN	JUL04/06
SECONDARY	MILLIMETERS	M.E. APP'D		
REFERENCE IN PARENTHESES		Q.A. APP'D		
GENERAL TOLERANCES		DWG APPR.		
1 DECIMAL PLACE	±.025	ENG. REL. NO.		
2 DECIMAL PLACES	±.020	REF.		
3 DECIMAL PLACES	±.015	THIRD ANGLE PROJECTION		
ANGULAR DEGREES	±1.0°	DO NOT SCALE DRAWING		

**Amphenol Canada Corp.**  
Commercial Products

MODULAR JACK, RJ45, VERTICAL MOUNT, 8P8C,  
SHIELD, WITH FLANGE, WITH LED OPTIONS, WITH  
.130" CONTACT TAIL LENGTH, RoHS COMPLIANT

DWG. NO. **RJHSE-338X-A1** REV **E**

CODE ID NO. 03554 | DWG SIZE: X | SCALE: 5:1 | SHEET 1 OF 2

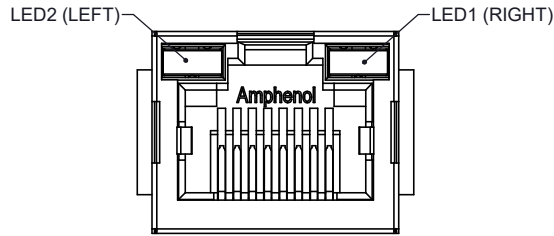

TYPICAL FOR SINGLE & MULTI-PORT

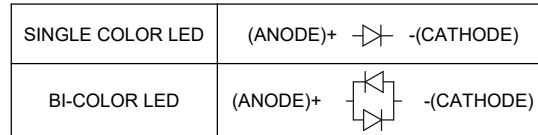

REVISIONS			
REV	DESCRIPTION, ECN, EAR NO.	DATE	APP'D
D	ADD LED OPTIONS SHEET	JUL26/21	L.C.
E	REVISE DIM PER REAL SHELL	AUG26/24	K.T.

LED SPECIFICATIONS:  
 FORWARD VOLTAGE: 2.1 VOLTS TYP.  
 FORWARD VOLTAGE: 2.9 VOLTS FOR WHITE  
 FORWARD VOLTAGE: 3.1 VOLTS FOR BLUE  
 REVERSE VOLTAGE: 5.0 VOLTS MAX.  
 LUMINOUS INTENSITY:  
 18.6 mcd MIN. (AT If=20mA) TYP.  
 480 mcd MIN. (AT If=5mA) FOR WHITE  
 110 mcd MIN. (AT If=20mA) FOR BLUE

OPERATING TEMPERATURE: -55° TO 85° C  
 LEAD SOLDERING TEMPERATURE: 260° C  
 PLATING ON TAILS: TIN OR TIN/COPPER  
 ALLOY OVER SILVER

PRIMARY COLOR FOR BI-COLOR  
 LEDS IN STANDARD ANODE/  
 CATHODE CONFIGURATION IS:  
 RED-GREEN= RED  
 RED-YELLOW= RED  
 GREEN-YELLOW= GREEN  
 GREEN-ORANGE= GREEN

LEGEND  
 BIC=BI-COLOR LED  
 LOWC=LOW CURRENT LED  
 YE=YELLOW  
 GR=GREEN  
 RD=RED  
 OR=ORANGE

NOTE:  
 THE TWO DIGITS PRECEDING THE  
 ADDITIONAL LED CODE MUST BE  
 USED IN THE PART NUMBER, WHEN  
 ORDERING ANY OF THE ADDITIONAL  
 LED OPTIONS.

**EXAMPLE:**

PART NUMBER RJHSE-338X-A1

LED COLOR CODE

CODE	LED2 (LEFT)	LED1 (RIGHT)	CODE	LED2 (LEFT)	LED1 (RIGHT)	CODE	LED2 (LEFT)	LED1 (RIGHT)
0	BLOCKED	BLOCKED	9	GREEN	BLOCKED	J	BIC RD/GR	YELLOW
1	YELLOW	GREEN	A	BIC GR/YE	BIC GR/YE	K	YELLOW	BIC GR/OR
2	BLOCKED	GREEN	B	BIC RD/GR	BIC RD/GR	L	BIC GR/YE	RED
3	YELLOW	BLOCKED	C	BIC RD/GR	BIC GR/YE	M	RED	YELLOW
4	GREEN	YELLOW	D	GREEN	BIC GR/YE	N	BIC GR/RD	BIC GR/YE
5	GREEN	GREEN	E	YELLOW	BIC GR/YE	P	GREEN	BIC RD/GR
6	YELLOW	YELLOW	F	BIC GR/YE	YELLOW	R	BIC GR/OR	GREEN
7	RED	GREEN	G	BIC GR/OR	BIC GR/OR	T	RED	RED
8	GREEN	RED	H	BIC GR/YE	GREEN	V	BIC RD/GR	GREEN
						W	ADDITIONAL OPTION	



PART NUMBER RJHSE-338W-A1Y

ADDITIONAL LED COLOR CODE

DENOTES ADDITIONAL LED OPTIONS TO BE USED

CODE	LED2 (LEFT)	LED1 (RIGHT)	CODE	LED2 (LEFT)	LED1 (RIGHT)	CODE	LED2 (LEFT)	LED1 (RIGHT)
0	DO NOT USE		F	GREEN	BIC GR/OR	Y	YELLOW	BIC YE/GR
1	RED	BLOCKED	G	GREEN	ORANGE			
2	BIC GR/OR	YELLOW	H	BIC OR/GR	BIC OR/GR	B	LOWC YE	LOWC GR
3	YELLOW	RED	J	BIC YE/GR	BIC YE/GR	C	LOWC GR	LOWC YE
4	BLOCKED	RED	K	BLOCKED	WHITE	D	LOWC GR	LOWC GR
5	BLOCKED	YELLOW	L	GREEN	BIC YE/GR			
6	RED	BIC RD/GR	N	BLUE	RED			
7	BLOCKED	BIC RD/GR	P	BLOCKED	BIC GR/YE			
8	BIC RD/GR	BLOCKED	R	BIC GR/RD	BIC GR/RD			
9	BIC GR/YE	BLOCKED	T	BLOCKED	BIC YE/GR			
A	BIC OR/GR	GREEN	U	ORANGE	BIC GR/YE			
E	BIC GR/YE	BIC GR/RD	V	BLOCKED	BIC GR/RD			



UNLESS SPECIFIED OTHERWISE	DRAWN	J.OUYANG	JUL04/06
PRIMARY UNITS	INCHES	CHECKED	L.CHAN
SECONDARY	MILLIMETERS	M.E. APP'D	JUL04/06
REFERENCE IN PARENTHESES		Q.A. APP'D	
GENERAL TOLERANCES		DWG APPR.	
1 DECIMAL PLACE	±.025	ENG. REL. NO.	
2 DECIMAL PLACES	±.020	REF.	
3 DECIMAL PLACES	±.015		
ANGULAR DEGREES	±1.0°	THIRD ANGLE PROJECTION	
		DO NOT SCALE DRAWING	

**Amphenol Canada Corp.**  
 Commercial Products

MODULAR JACK, RJ45, VERTICAL MOUNT, 8P8C, SHIELD, WITH FLANGE, WITH LED OPTIONS, WITH .130" CONTACT TAIL LENGTH, RoHS COMPLIANT

DWG. NO. **RJHSE-338X-A1**

CODE ID NO. 03554 | DWG SIZE: X | SCALE: 4:1 | SHEET 2 OF 2