



CE TEST REPORT

FOR

SATA Flash Drive

Model : SX250-25

Trade Name : Apacer

Issued to

Apacer Technology Inc.

1F., No.32, Zhongcheng Rd., Tucheng Dist., New Taipei City 236, Taiwan
(R.O.C)

Issued by

WH Technology Corp.

Open Site		No.120, Ln. 5, Hudong St., Xizhi Dist., New Taipei City 221, Taiwan ,(R.O.C.)
EMC Test Site	Xizhi Office and Lab	7F., No.262, Sec. 3, Datong Rd., Xizhi Dist., New Taipei City 221, Taiwan, (R.O.C.)
Tel.: +886-2-7729-7707 Fax: +886-2- 8648-1311		

Note: This test refers exclusively to the test presented test model and sample. This report shall not be reproduced except in full, without the written approval of WH Technology Corp. This document may be altered or revised by WH Technology Corp. Personnel only, and shall be noted in the revision section of the document.



TABLE OF CONTENTS	2
1. GENERAL INFORMATION	4
1.1 DESCRIPTION OF THE TESTED SAMPLES	5
1.2 SUMMARY OF TEST RESULT	6
1.3 TEST METHODOLOGY	7
1.4 DESCRIPTION OF THE SUPPORT EQUIPMENTS	8
1.5 FEATURES OF EUT:	8
PLEASE REFER TO USER MANUAL OR PRODUCT SPECIFICATION.	8
2. INSTRUMENT AND CALIBRATION	9
2.1 MEASURING INSTRUMENT CALIBRATION	9
2.2 TEST AND MEASUREMENT EQUIPMENT	9
2.3 TEST PERFORMED	10
2.4 APPENDIX	10
3. CONDUCTED EMISSION MEASUREMENT	13
3.1 TEST SET-UP	13
3.2 LIMIT	13
3.3 TEST PROCEDURE	13
3.4 TEST SPECIFICATION	14
3.5 RESULT: PASSED	14
3.6 TEST DATA:	14
4. RADIATED EMISSION MEASUREMENT	15
4.1 TEST SETUP	15
4.2 LIMIT	16
4.3 TEST PROCEDURE	16
4.4 TEST SPECIFICATION	17
4.5 RESULT: PASSED	17
4.6 TEST DATA:	17
PLEASE REFER TO APPENDIX 2	17
5. POWER HARMONIC MEASUREMENT	18
5.1 TEST SETUP	18
5.2 LIMIT OF HARMONIC CURRENT	18
5.3 TEST PROCEDURE	18
5.4 TEST SPECIFICATION	18
5.5 RESULT: PASSED	18
5.6 TEST DATA:	19
6. VOLTAGE FLUCTUATIONS	20
6.1 TEST SETUP	20
6.2 VOLTAGE FLUCTUATIONS TEST	20
6.3 TEST PROCEDURE	20
6.4 TEST SPECIFICATION	20
6.5 RESULT: PASSED	20
6.6 TEST DATA:	20
7. ELECTROSTATIC DISCHARGE IMMUNITY TEST (ESD)	21
7.1 TEST PROCEDURE	21
7.2 TEST SETUP	21
7.3 TEST LEVEL	21
7.4 TEST RESULT.	22
8. RADIATED SUSCEPTIBILITY MEASUREMENT (RS)	24



8.1	TEST SETUP-----	24
8.2	TEST PROCEDURE-----	24
8.3	TEST LEVEL -----	24
8.4	TEST PROCEDURE -----	25
8.5	TEST RESULT -----	25
9.	ELECTRICAL FAST TRANSIENT/BURST (EFT)-----	27
9.1	TEST SETUP-----	27
9.2	TEST PROCEDURE-----	27
9.3	TEST PROCEDURE -----	27
9.4	TEST LEVEL -----	28
9.5	TEST RESULT -----	28
10.	SURGE-----	29
10.1	TEST SETUP-----	29
10.2	TEST PROCEDURE-----	29
10.3	TEST LEVEL -----	29
10.4	TEST PROCEDURE -----	30
10.5	TEST RESULT -----	30
11.	IMMUNITY TEST TO CS CONDUCTED DISTURBANCE (CS)-----	31
11.1	TEST SETUP-----	31
11.2	TEST PROCEDURE-----	31
11.3	TEST LEVEL -----	31
11.4	TEST PROCEDURE -----	32
11.5	TEST RESULT -----	32
12.	POWER FREQUENCY MAGNETIC FIELD (MAGNETIC)-----	34
12.1	TEST SETUP-----	34
12.2	TEST STANDARD-----	34
12.3	TEST LEVEL -----	34
12.4	TEST PROCEDURE -----	34
12.5	TEST RESULT -----	35
13.	VOLTAGE DIPS AND INTERRUPTION MEASUREMENT-----	36
13.1	TEST SETUP -----	36
13.2	TEST PROCEDURE-----	36
13.3	TEST LEVEL -----	37
13.4	TEST PROCEDURE -----	37
13.5	TEST RESULT -----	38
14.	PERFORMANCE CRITERIA -----	39
15.	MEASUREMENT UNCERTAINTY -----	40
APPENDIX 1		
PHOTOS OF TEST CONFIGURATION		
APPENDIX 2		
TEST DATA		
APPENDIX 3		
PHOTOS OF EUT		



1. GENERAL INFORMATION

Applicant : Apacer Technology Inc.
Address : 1F., No.32, Zhongcheng Rd., Tucheng Dist., New Taipei City 236, Taiwan (R.O.C)
Manufacturer : Apacer Technology Inc.
Address : 1F., No.32, Zhongcheng Rd., Tucheng Dist., New Taipei City 236, Taiwan (R.O.C)
EUT : SATA Flash Drive
Model Name : SX250-25
Model Differences : N/A
Receipt Date : Oct. 01, 2018
Final Test Date : Oct. 09, 2018

Measurement procedure used:

EMI :

EN 55032 : 2015
EN 61000-3-2 : 2014
EN 61000-3-3 : 2013
CISPR 32 : 2012

EMS:

EN 55035 : 2017
IEC 61000-4-2 : 2009
IEC 61000-4-3 : 2006+A1: 2007+A2:2010
IEC 61000-4-4 : 2012
IEC 61000-4-5 : 2014+A1:2017
IEC 61000-4-6 : 2013/COR1:2015
IEC 61000-4-8 : 2010
IEC 61000-4-11 : 2004+A1:2017

Deviation from Applicable Standard

The above equipment was tested by WH Technology Corp. for compliance with EMC requirements set forth in the EUROPEAN COUNCIL DIRECTIVE 2014/30/EU and the technical standards mentioned above. The results of testing in this report apply only to the product/system, which was tested. Other similar equipment will not necessarily produce the same results due to production tolerance.

This test report shall not be reproducing in part without written approval of WH Technology Corp.

Tested By:

Reviewed by:

Oct. 09, 2018

Date

Bing Zhang/ Engineer

Oct. 09, 2018

Date

Bell Wei / Manager
TAF Accreditation Number: 2954



1.1 DESCRIPTION OF THE TESTED SAMPLES

EUT

EUT Type : Engineer Type
Condition when received : Good Damage :
EUT Name : SATA Flash Drive
Model Number : SX250-25
Receipt Date : 10/01/2018
EUT Power Rating : AC Power
 DC Power
 DCV from PC
 DCV from Adaptor
EUT highest operating frequency : Above 1GHz
EUT peripheral EQUIPMENT : N/A
I/O Port of EUT : N/A



1.2 SUMMARY OF TEST RESULT

Emission			
Test Standard	Test Item	Test Result	Worse Emission
EN55032 Class B	Conducted Emission	Pass	Line 3.62 MHz, 12.83 dB Margin
EN55032 Class B	Radiated Emission	Pass	Below 1GHz Vertical 197.81 MHz, 5.11 dB Margin Above 1GHz Vertical 5316.00 MHz, 25.41 dB Margin

Immunity				
Test Standard	Test Item	Performance Criteria	Observed Result Class	Test Result
IEC61000-4-2	Electrostatic Discharge	B	A	Pass
IEC61000-4-3	Radiated Susceptibility	A	A	Pass
IEC61000-4-4	Electrical Fast Transient	B	A	Pass
IEC61000-4-5	Surge	B	A	Pass
IEC61000-4-6	Conducted Susceptibility	A	A	Pass
IEC61000-4-8	Magnetic Field	A	A	Pass
IEC61000-4-11	Voltage Dips and Interruption	Dips >95% B	B	Pass
		Dips 30% C	C	Pass
		Interruptions >95% C	C	Pass



1.3 TEST METHODOLOGY

1.3.1 EUT SYSTEM OPERATION

1. EUT is fully system and power on.
2. Exercise software is EMCTEST and run ITU-R BT 1729 color bar.
3. Perform the EMC testing procedures, and measure the maximum emission noise.

1.3.2 DESCRIPITON OF TEST MODES

To investigate the maximum EMI emission characteristics generates from EUT, the test system was pre-scanning tested base on the consideration of following EUT operation mode or test configuration mode which possible have effect on EMI emission level. Each of these EUT operation mode(s) or test configuration mode(s) mentioned above was evaluated respectively.

Pretest Test Mode	Description
Mode 1	Working

Conducted emission test	
Final Test Mode	Description
Mode 1	Working

Radiated emission test	
Final Test Mode	Description
Mode 1	Working

Harmonic current emissions & Voltage changes, fluctuations and flicker test	
Final Test Mode	Description
Mode 1	Working

Immunity emission test	
Final Test Mode	Description
Mode 1	Working



1.4 DESCRIPTION OF THE SUPPORT EQUIPMENTS

Setup Diagram

See test photographs attached in appendix 1 for the actual connections between EUT and support equipment.

Support Equipment

OUTSIDE SUPPORT EQUIPMENT							
No.	Equipment	Model	Serial No.	FCC ID/ BSMI ID	Trade name	Data Cable	Power Cord
1.	PC	D13M	FZHBW02	R33002	DELL	N/A	Unshielded 1.8m
2.	Monitor	UZ2315Hf	CN-0NJ1C5- 72872-473- AF2SREVA 02	R43002	DELL	Shielded 1.8m	Unshielded 1.8m
3.	Printer	D4360	N/A	R33001	HP	Shielded 1.8m / USB	Unshielded 1.8m
4.	USB 3.0	TC100-001	NA	D43606	TCELL	Shielded 1m / USB	N/A
5.	Mouse	MS116p	CN-04DWD N-73826-5C M-0120	R41108	DELL	Shielded 1.8m / USB	N/A
6.	Keyboard	KB216p	CN-005TW2- 71581-5AF-01 I3-A01	D41108	DELL	Shielded 1.8m / USB	N/A

Note: All the above equipment /cable were placed in worse case position to maximize emission signals during emission test.

Grounding: Grounding was in accordance with the manufacturer’s requirement and conditions for the intended use.

1.5 FEATURES OF EUT:

PLEASE REFER TO USER MANUAL OR PRODUCT SPECIFICATION.



2. INSTRUMENT AND CALIBRATION

2.1 MEASURING INSTRUMENT CALIBRATION

The measuring equipment utilized to perform the tests documented in the report has been calibrated once a year or in accordance with the manufacturer's recommendations, and is traceable to recognized national standards.

2.2 TEST AND MEASUREMENT EQUIPMENT

The following list contains measurement equipment used for testing. The equipment conforms to the requirement of CISPR 16-1, ANSI C63.2 and. Other required standards.

Calibration of all test and measurement, including any accessories that may effect such calibration, is checked frequently to ensure the accuracy. Adjustments are made and correction factors are applied in accordance with the instructions contained in the respective.

TABLELIST OF TEST AND MEASUREMENT EQUIPMENT

Test Site	Instrument	Manufacturer	Model No.	S/N	Next Cal. Date
Conduction	Spectrum (9K--3GHz)	R&S	FSP3	833387/010	2018/12/07
	EMI Receiver	R&S	ESHS10	830223/008	2019/06/10
	LISN	Rolf Heine Hochfrequenztechnik	NNB-2/16z	98062	2019/06/13
	ISN	Schwarzbeck	8-Wire ISN CAT5	CAT5-8158-0094	2018/10/19
	RF Cable	N/A	N/A	EMI-3	2018/10/17
Radiation	Bilog antenna(30M-1GHz)	ETC	MCTD2786B	BLB16M04004/JB-5-004	2019/05/30
	Double Ridged Guide Horn antenna(1G-18GHz)	ETC	MCTD 1209	DRH15N02009	2018/11/28
	Horn antenna (18G-26GHz)	com-power	AH-826	81000	2019/08/16
	LOOP Antenna (Below 30MHz)	com-power	AL-130	17117	2018/11/12
	Pre amplifier (30M-1GHz)	EMC INSTRUMENT	EMC9135	980334	2019/05/08
	Microwave Preamplifier (1G-18GHz)	EMC INSTRUMENT	EMC051845	980108&A T -18001	2018/11/27



	Pre amplifier (18G~26GHz)	MITEQ	JS4-18002600-30-5A	808329	2019/08/09
	EMI Test Receiver	R&S	ESVS30 (20M-1000MHz)	826006/002	2018/11/07
	RF Cable (9K-1GHz)	EMCI	N male on end of both sides (EMI4)	30m	2018/11/09
	RF CABLE (1~26GHz)	SUCOFLEX	104PEA	NA	2019/05/07
	RF CABLE (1~18GHz)	HARBOUR INDUSTRIES	LL142MI(7M)	NA	2019/08/09
	RF CABLE (18~26GHz)	AGILENT	EMC102-KM-KM-600	160102	2019/04/18
	Spectrum (9K--7GHz)	R&S	FSP7	830180/006	2019/04/18
	Spectrum (9K--40GHz)	AGILENT	8564EC	4046A0032	2019/02/28
Software	e3	AUDIX	N/A	N/A	N/A
SG	SINGAL GENERATOR (100k-1GHz)	HP	8648A	3619U00426	N/A

#: CALIBRATION INTERVAL OF INSTRUMENTS LISTED ABOVE IS ONE YEAR

2.3 TEST PERFORMED

Conducted emissions were investigated over the frequency range from 0.15 MHz to 30 MHz using a receiver which resolution bandwidth is set at 9 KHz.

Radiated emissions were investigated over the frequency range from 30 MHz to 1000 MHz using a receiver which resolution bandwidth is set at 120 KHz. Radiated measurement was performed at distance that from an antenna to EUT is 10 meters.

2.4 APPENDIX

Appendix A: Measurement Procedure for Main Power Port Conducted Emissions

The measurements are performed in a WH lab test room; The EUT was placed on non-conductive 1.0m x 1.5m table, which is 0.8 meters above an earth-grounded.

Power to the EUT was provided through the LISN which has the Impedance (50 ohm/50 uH) vs. Frequency Characteristic in accordance with the standard. Powers to the LISNs were filtered to eliminate ambient signal interference and these filters were bonded to the ground plane. Peripheral equipment required to provide a functional system (support equipment) for EUT testing was powered from the second LISN through a ganged, metal power outlet box which is bonded to the ground plane at the LISN.

If the EUT is supplied with a flexible power cord, the power cord length in excess of the distance separating the EUT from the LISN shall be folded back and forth at



the center of the lead so as to form a bundle not exceeding 40cm in length. If the EUT is provided with a permanently coiled power cord, bundling of the cord is not required. If the EUT is supplied without a power cord, the EUT shall be connected to the LISN by a power cord of the type specified by the manufacturer which shall not be longer than 1 meter. The excess power cord shall be bundled as described above. If a non-flexible power cord is provided with the EUT, it shall be cut to the length necessary to attach the EUT to the LISN and shall not be bundled.

The interconnecting cables were arranged and moved to get the maximum measurement. Both the line of power cord, hot and neutral, was measured.

The highest emissions were analyzed in details by operating the spectrum analyzer in fixed tuned mode to determine the nature of the emissions and to provide information which could be useful in reducing their amplitude.

Appendix B: Test Procedure for Radiated Emissions

Preliminary Measurements in Semi Anechoic Chamber

The radiated emissions are initially measured in the anechoic chamber at a measurement distance of 3 meters. Desktop EUT are placed on a wooden stand 0.8 meter in height. The measurement antenna is 3 meters from the EUT. The test setup in anechoic chamber is the same as open site. The turntable rotated 360°C. The antenna height is 1m. The primary objective of the radiated measurements in the anechoic chamber is to identify the frequency spectrum in the absence of the electromagnetic environment existing on the open test site. The frequencies can then be pre-selected on the open test site to obtain the corresponding amplitude. The initial scan is made with the spectrum analyzer in automatic sweep mode. The spectrum peaks are then measured manually to determine the exact frequencies.



Measurements on the Open Site

The radiated emissions test will then be repeated on the open site or chamber to measure the amplitudes accurately and without the multiple reflections existing in the shielded room. The EUT and support equipments are set up on the turntable. Desktop EUT are set up on a wooden stand 0.8 meter above the ground.

For the initial measurements, the receiving antenna is varied from 1-4 meter height and is changed in the vertical plane from vertical to horizontal polarization at each frequency. Both reading are recorded with the quasi-peak detector with 120 KHz bandwidth. For frequency between 30 MHz and 1000 MHz, the reading is recorded with peak detector or quasi-peak detector.

At the highest amplitudes observed, the EUT is rotated in the horizontal plane while changing the antenna polarization in the vertical plane to maximize the reading. The interconnecting cables were arranged and moved to get the maximum measurement. Once the maximum reading is obtained, the antenna elevation and polarization will be varied between specified limits to maximize the readings.



3. CONDUCTED EMISSION MEASUREMENT

3.1 TEST SET-UP

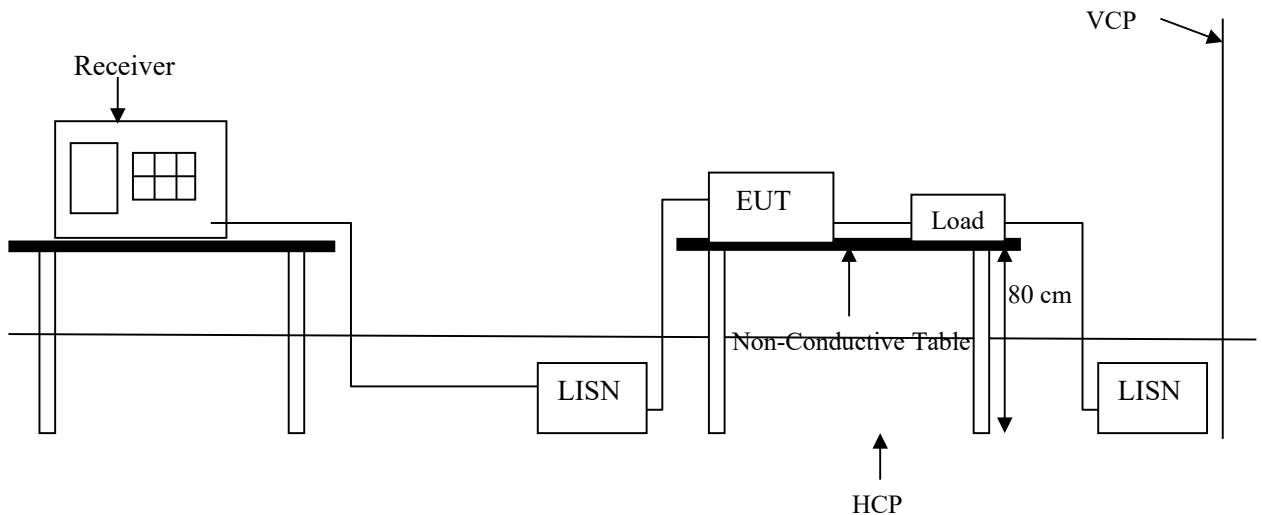

3.2 LIMIT

Frequency range (MHz)	CLASS A		CLASS B	
	QP dB(uV)	Average dB(uV)	QP dB(uV)	Average dB(uV)
0.15-0.5	79 dBuV	66 dBuV	66 - 56 dBuV	56 - 46 dBuV
0.5-5.0	73 dBuV	60 dBuV	56 dBuV	46 dBuV
5.0-30.0	73 dBuV	60 dBuV	60 dBuV	50 dBuV

Remark: In the above table, the tighter limit applies at the band edges.

3.3 TEST PROCEDURE

Please refer 2.4 Appendix

Appendix A: Measurement Procedure for Main Power Port Conducted Emissions.

Note:

1. Reading in which marked as Peak, QP or AVG means measurements by using are Quasi-Peak or Average Mode with Detector BW=9 kHz (6 dB Bandwidth).
2. All readings are Peak Mode value unless otherwise stated QP or AVG in column of Note. If the Peak or QP Mode Measured value compliance with the QP Limits and lower than AVG Limits, the EUT shall be deemed to meet both QP & AVG Limits and then only Peak or QP Mode was measured, but AVG Mode didn't perform.



3.4 TEST SPECIFICATION

According to EN 55032 CLASS B

(Please refer to Page 4 for dated references which are related to the standard as mentioned above)

3.5 RESULT: PASSED

EMI Receiver/Spectrum Analyzer Configuration (for the frequencies tested)

Frequency Range:	150 KHz—30 MHz
Detector Function:	Quasi-Peak / Average Mode
Resolution Bandwidth:	9 KHz
Temperature:	26 °C
Humidity:	43 % RH

3.6 TEST DATA:

Please refer to appendix 2



4. RADIATED EMISSION MEASUREMENT

4.1 TEST SETUP

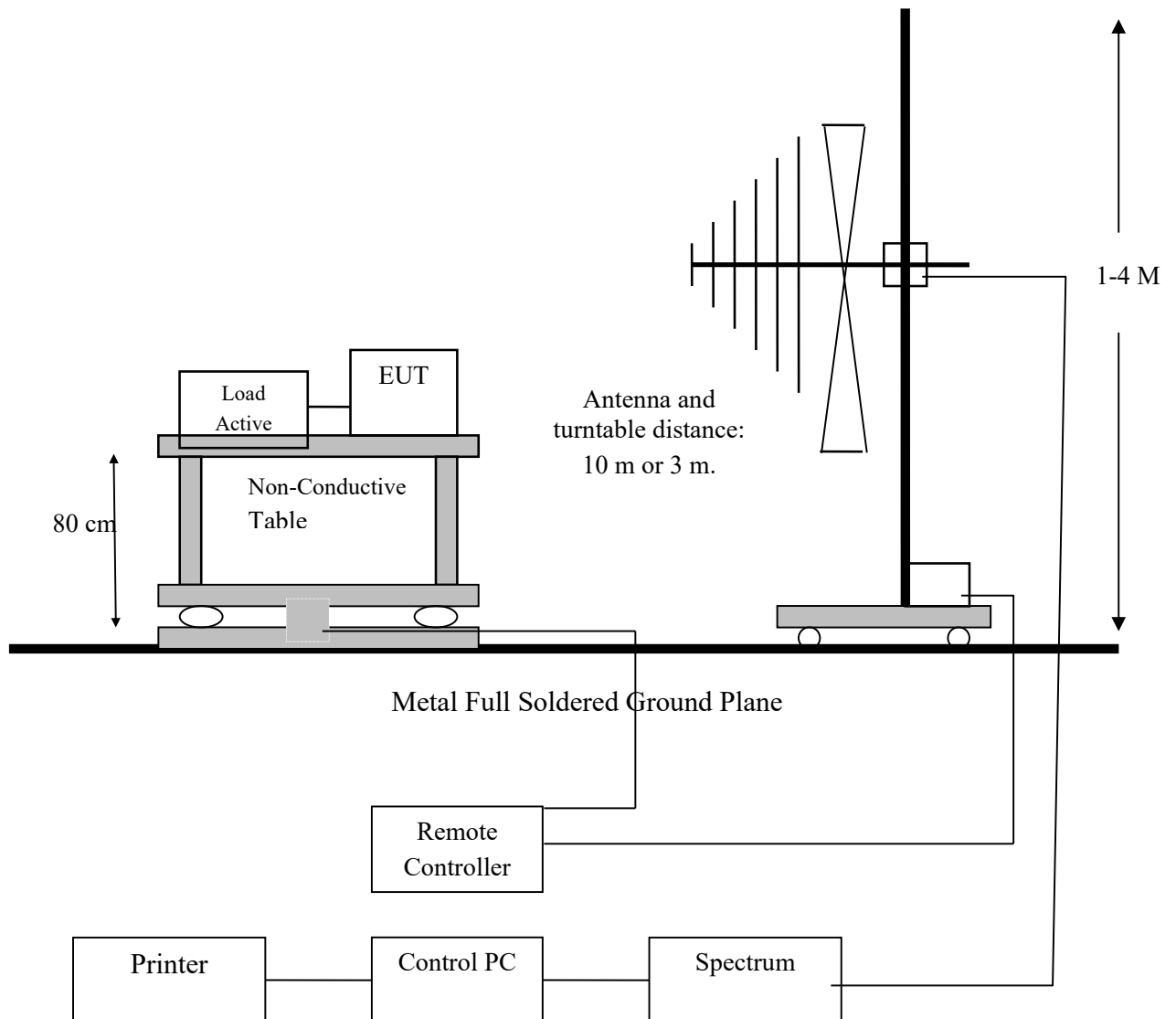



4.2 LIMIT

Frequency MHz	Class A		Class B	
	Distance (Meter)	Limit dB μ V/m	Distance (Meter)	Limit dB μ V/m
30 ~ 230	10	40	10	30
230 ~ 1000	10	47	10	37

For Class A

Frequency range GHz	Average limit dB(μ V/m)	Peak limit dB(μ V/m)
1 to 3	56	76
3 to 6	60	80
NOTE The lower limit applies at the transition frequency.		

For Class B

Frequency range GHz	Average limit dB(μ V/m)	Peak limit dB(μ V/m)
1 to 3	50	70
3 to 6	54	74
NOTE The lower limit applies at the transition frequency.		

Remark: In the above table, the tighter limit applies at the band edges.

4.3 TEST PROCEDURE

Please refer 2.4 Appendix

Appendix B: Test Procedure for Radiated Emissions

Note:

Below 1GHz

1. Reading in which marked as QP or Peak means measurements by using are Quasi-Peak Mode with Detector BW=120 kHz..

2. All readings are Peak unless otherwise stated QP in column of Note. Peak denotes that the Peak reading compliance with the QP Limits and then QP Mode measurement didn't perform.

Above 1 GHz

1. Reading in which marked as Peak means measurements by using are Peak Mode with instrument setting in RBW=1 MHz, VBW= 1MHz.



Reading in which marked as AV means measurements by using are Average Mode with instruments setting in RBW=1 MHz, VBW= 1MHz.

2.All readings are Peak Mode value unless otherwise stated AVG in column of Note. If the Peak be deemed to meet both Peak & AVG Limits and then only Peak Mode was measured, but AVG Mode didn't perform.

4.4 TEST SPECIFICATION

According to EN 55032 CLASS B

(Please refer to Page 4 for dated references which are related to the standard as mentioned above)

4.5 RESULT: PASSED

Temperature:	27 °C
Humidity:	49 % RH

4.6 TEST DATA:

Please refer to appendix 2



5. POWER HARMONIC MEASUREMENT

5.1 TEST SETUP

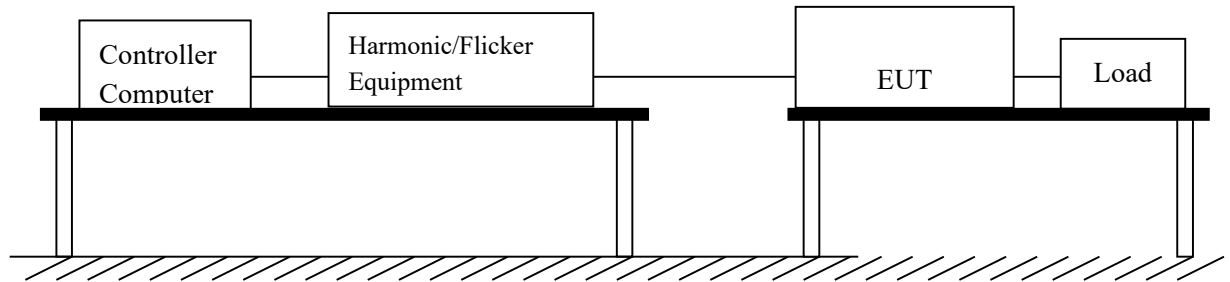

5.2 LIMIT OF HARMONIC CURRENT

Limit of Harmonic Currents

Harmonic Order	Maximum Permissible Harmonic Current (Ampere)	Harmonic Order	Maximum Permissible Harmonic Current (Ampere)
Odd Harmonic		Even Harmonic	
3	2.30	2	1.08
5	1.14	4	0.43
7	0.77	6	0.30
9	0.40	$8 \leq n \leq 40$	$0.23 \times 8/n$
11	0.33		
13	0.21		
$15 \leq n \leq 39$	$0.15 \times 15/n$		

5.3 TEST PROCEDURE

The EUT is supplied in series with power analyzer from a power source has the same normal voltage and frequency as the rated supply voltage and the equipment under test. The rated voltage at the supply voltage of EUT of 0.94 time and 1.06 times shall be performed.

5.4 TEST SPECIFICATION

According to EN 61000-3-2

(Please refer to Page 4 for dated references which are related to the standard as mentioned above)

5.5 RESULT: PASSED

Temperature:	25 °C
Humidity:	45 % RH



5.6 TEST DATA:

Please refer to appendix 2



6. VOLTAGE FLUCTUATIONS

6.1 TEST SETUP

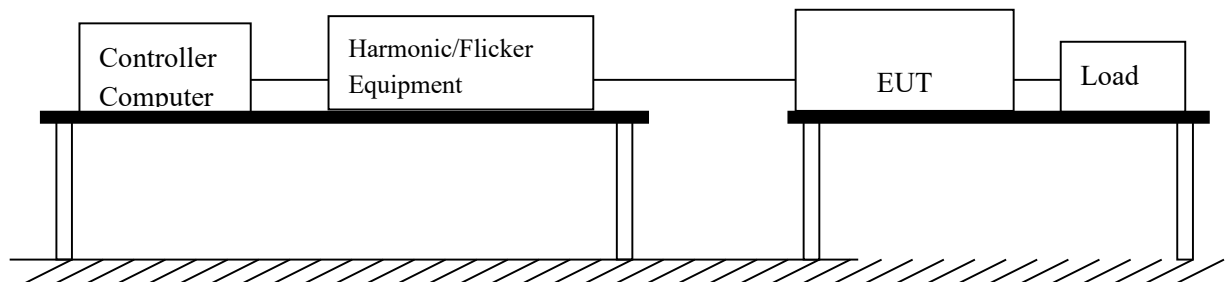

6.2 VOLTAGE FLUCTUATIONS TEST

Port:	AC mains
Basic Standard:	EN61000-3-3
Test Procedure	Refer to paragraph 6.3
Observation period:	For Pst 10min
	For Plt 2 hours

6.3 TEST PROCEDURE

The EUT is supplied in series with reference impedance from a power source with the voltage and frequency as the nominal supply voltage and frequency of the EUT.

6.4 TEST SPECIFICATION

According to EN 61000-3-3

According to EN55032 CLASS B

(Please refers to Page 4 for dated references which are related to the standard as mentioned above)

6.5 RESULT: PASSED

Temperature:	25 °C
Humidity:	45 % RH

6.6 TEST DATA:

Please refer to appendix 2



7. ELECTROSTATIC DISCHARGE IMMUNITY TEST (ESD)

7.1 TEST PROCEDURE

According To IEC 61000-4-2

According To EN 55035

(Please refer to Page 4 for dated references which are related to the standard as mentioned above)

7.2 TEST SETUP

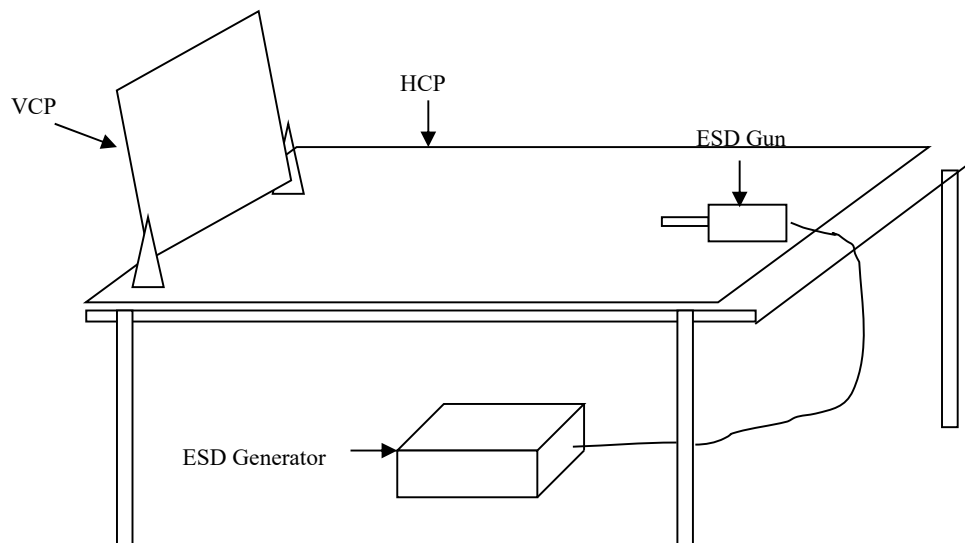

7.3 TEST LEVEL

Item	Test Specification	Unit	Performance Criteria
Enclosure Room	±2, 4, 8, 15 KV (Air Discharge)	KV (Charge Voltage)	B
Electrostatic Discharge	±2, 4, 6, 8 KV (Contact Discharge)		
Time between test	<u>1</u>	sec	

Number of test: 10 Discharges / Test point / Polarity / Level

Particular requirements: at least 200 discharges, 100 each at negative and positive polarity, at a minimum of four test points.

When the measurement was taken, The ESD discharger was performed in single discharge. For the single discharge time between successive single discharges will keep on one second. It was at least ten single discharges with positive and negative at the same selected pointed. The selected pointed, which was performed with electrostatic discharge, was marked on the red label on the EUT Indirect applicant of discharge to the EUT

Vertical Coupling Plane (VCP)



The coupling plane, of dimensions 0.5 m x 0.5 m, is placed parallel to, and positioned at a distance 0.1 m from, the EUT, with the discharge electrode touching the coupling plane.

The four faces of the EUT will be performed with electrostatic discharge. It was at least ten singles discharges with positive and negative at the same selected point.

Horizontal Coupling Plane (HCP)

The coupling plane is placed under the EUT. The generator shall be positioned vertically at a distance of 0.1m from the EUT, with the discharge electrode touching the coupling.

The four faces of the EUT will be performed with electrostatic discharge. It was at least ten single discharges with positive and negative at the same selected pointed.

7.4 TEST RESULT.

Model: SX250-25

Temperature: 25 °C , Humidity: 45 % RH

Voltage	Contact Discharge				Air Discharge					
	2KV		4KV		2KV		4KV		8KV	
Polarity	+	-	+	-	+	-	+	-	+	-
Case	A	A	A	A	/	/	/	/	/	/
SCREW	A	A	A	A	/	/	/	/	/	/
I/P Port	/	/	/	/	A	A	A	A	A	A
HCP	A	A	A	A	A	A	A	A	A	A
VCP	A	A	A	A	A	A	A	A	A	A

Performance Criteria:

- A) Normal performance within the specification;
- B) Temporary degradation or less of function of performance which is self recoverable;
- C) Temporary degradation or less of function or perform. Which requires. operate intervention or system reset;
- D) Degradation or loss of function which is not recoverable due to damage of equipment (components) or software, or loss of data;

"/" : no test.



Test points please refer below photos.



Red dot: Contact; Blue dot: Air

Final Result: **PASSED**

Remark:

Photos of test configuration please refer to appendix 1.



8. RADIATED SUSCEPTIBILITY MEASUREMENT (RS)

8.1 TEST SETUP

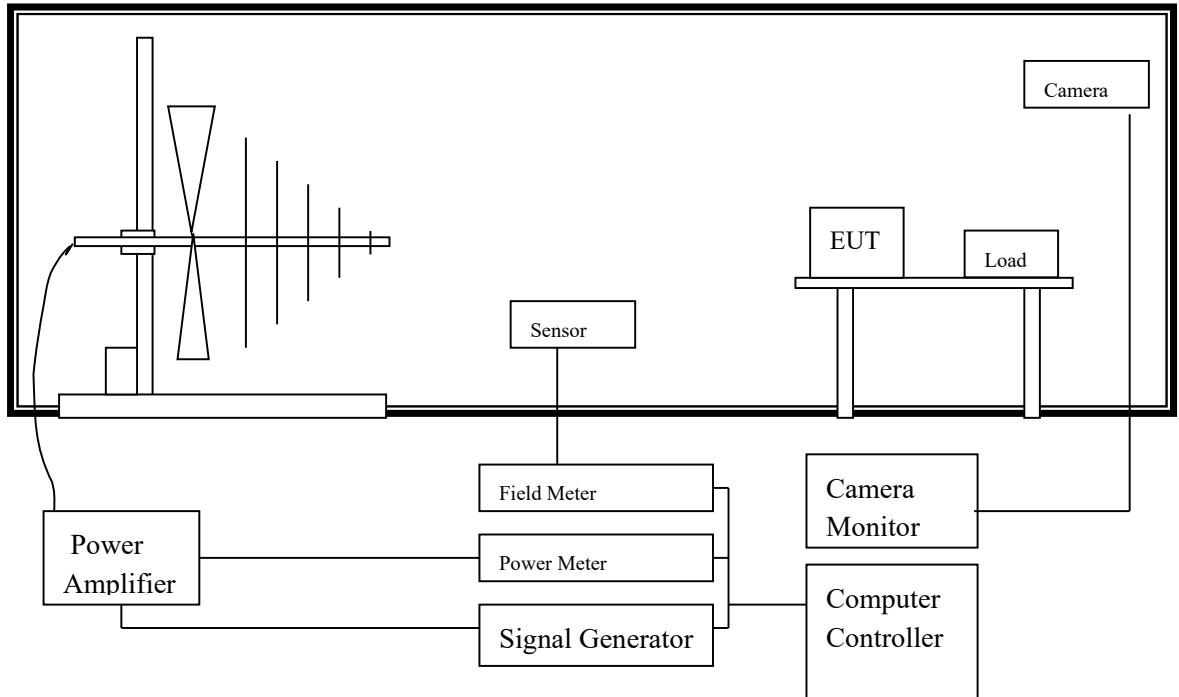

8.2 TEST PROCEDURE

According To IEC 61000-4-3

According To EN 55035

(Please refer to Page 4 for dated references which are related to the standard as mentioned above)

8.3 TEST LEVEL

Item	Test Specification	Unit	Performance Criteria
Radio –Frequency	80~1000	MHz	A
Electromagnetic Field	3	V/m (unmodulated, rms)	
Amplitude Modulated	80	%AM (1 KHz)	



8.4 TEST PROCEDURE

The EUT and load, which are placed on a wooden table whose height is 0.8 meter aboveground, are placed with one coincident with the calibration plane such that the distance from antenna to the EUT is 3 meters.

Both horizontal and vertical polarization of the antenna position and four sides of the EUT are set on measurement. In order to judge the EUT performance, a CCD camera is used to monitor the situation of EUT.

All the scanning conditions are as follows:

Condition of Test	Remarks
1. Field Strength	3 V/m; Level 2
2. Radiated Signal	AM 80% modulated with 1 KHz
3. Scanning Frequencies	80 MHz ~ 1000 MHz
4. Dwell Time	3 seconds
5. Frequency step size	1%
6. The rate of swept of frequency	1.5×10^{-3} decades/s
7. Antenna Polarity	HORIZONTAL & VERTICAL
8. The four sides of EUT are tested	FRONT, REAR, RIGHT, LEFT

8.5 TEST RESULT

Model: SX250-25

Temperature: 25 °C , Humidity: 45 % RH

ANT SIDE	3 V HORIZONTAL	3 V VERTICAL	RESULT
FRONT	A	A	PASSED
REAR	A	A	PASSED
RIGHT	A	A	PASSED
LEFT	A	A	PASSED



Performance Criteria:

- A) Normal performance within the specification;
 - B) Temporary degradation or less of function of performance which is self recoverable;
 - C) Temporary degradation or less of function or perform. Which requires. operate intervention or system reset;
 - D) Degradation or loss of function which is not recoverable due to damage of equipment (components) or software, or loss of data;
- "/" : no test.

Final Result: **PASSED**

Remark:

Photos of test configuration please refer to appendix 1.



9. ELECTRICAL FAST TRANSIENT/BURST (EFT)

9.1 TEST SETUP

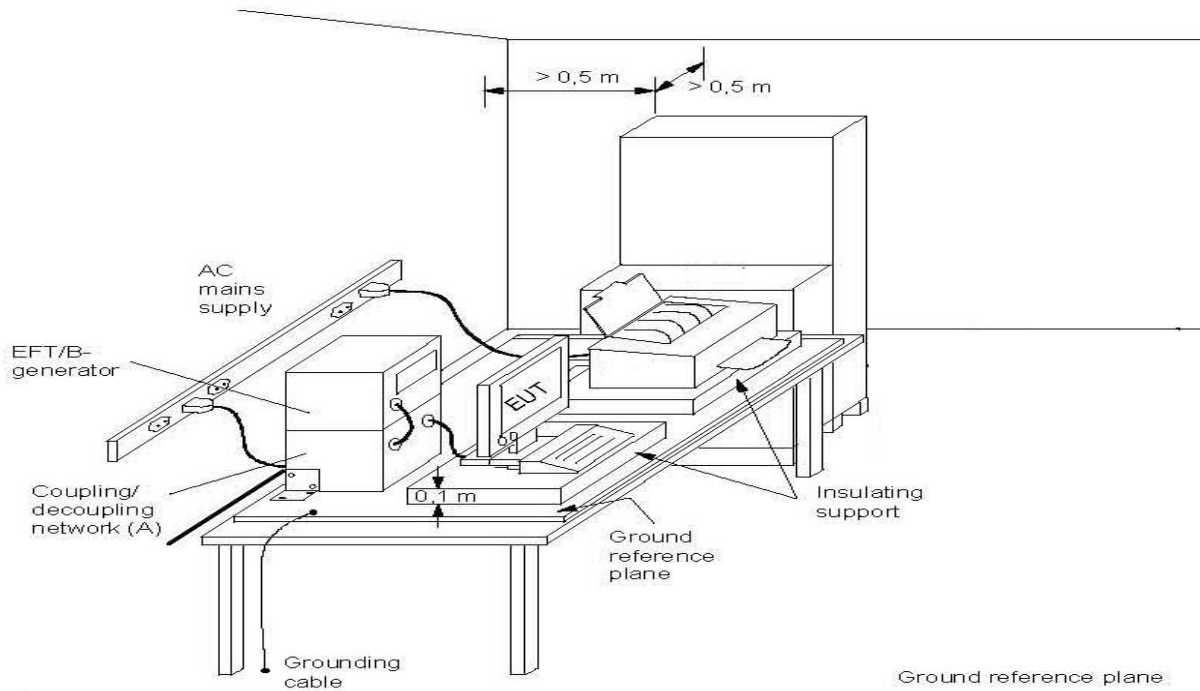

9.2 TEST PROCEDURE

According To IEC 61000-4-4

According To EN 55035

(Please refer to Page 4 for dated references which are related to the standard as mentioned above)

9.3 TEST PROCEDURE

The EUT and load are placed on a ground reference plane and insulated from it by an insulating support $0,1\text{ m} \pm 0,01\text{ m}$ thick. The minimum area of the ground reference plane is $1\text{ m} \times 1\text{ m}$. It also projected beyond the EUT by at least 0.1 meter on all sides.

For Input and Output AC power or DC Input and DC Output Power Ports:

The EUT is connected with the power mains through a coupling device that directly couples the EFT interference signal.

Each of the line and nature conductors is impressed with burst noise for 1 minute.

For Protective Earth Port:

The EUT is connected to the power mains through a coupling device that directly couples the EFT interference signal. The protective earth line (PE) is impressed with burst noise for 1 minute.

The length of power cord between the coupling device and the EUT shall be $0.5\text{ m} \pm 0.05\text{ m}$.

For signal Lines and Control Lines Test:



The EFT interference signal is through a coupling clamp device couples to the signal and control lines of the EUT with burst noise for 1 minute.

9.4 TEST LEVEL

Item	Test Specification	Unit	Performance Criteria
Test Voltage	±0.5, ±1	KV (Peak)	B
Pulse Rise time & Duration	5/50	Tr/Ts (ns)	
Pulse Repetition	5	Rep. Frequency (KHz)	

9.5 TEST RESULT

Model: SX250-25

Temperature: 25 °C , Humidity: 45 % RH

Test Point/ Mode / Result		0.5 KV		1 KV		2 KV	
		+	-	+	-	+	-
Power Line	L	A	A	A	A	/	/
	N	A	A	A	A	/	/
	G	A	A	A	A	/	/
Signal Line Clamp Test		/	/	/	/	/	/

Performance Criteria:

- A) Normal performance within the specification;
 - B) Temporary degradation or less of function of performance which is self recoverable;
 - C) Temporary degradation or less of function or perform. Which requires. operate intervention or system reset;
 - D) Degradation or loss of function which is not recoverable due to damage of equipment (components) or software, or loss of data;
- "/" : no test.

Final Result: **PASSED**

Remark:

Photos of test configuration please refer to appendix 1.



10. SURGE

10.1 TEST SETUP

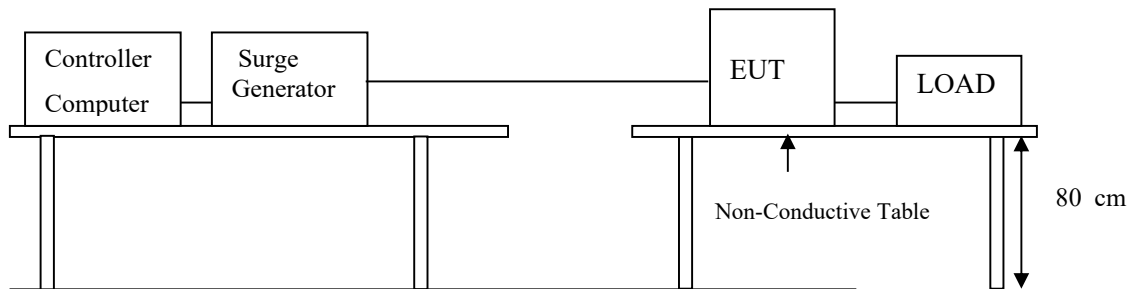

10.2 TEST PROCEDURE

According To IEC 61000-4-5

According To EN 55035

(Please refer to Page 4 for dated references which are related to the standard as mentioned above)

10.3 TEST LEVEL

Item	Test Specification	Unit	Performance Criteria
DC Input and DC Output Power Ports			
Surge	1.2/50(8/20)	Tr/Ts (μs)	B
Line to Ground	±0.5	KV	
Line to Line	±0.5	KV	
AC Input and AC Output Power Ports			
Surge	1.2/50(8/20)	Tr/Ts (μs)	B
Line to Ground	±2	KV	
Line to Line	±1	KV	
Polarity	POSITIVE / NEGATIVE		
Phase shifting in a range between 0° to 360°			



10.4 TEST PROCEDURE

The EUT and its load are placed on a table which is 0.8 meter height. The length of power cord between the coupling device and the EUT shall be 2 meters or less.

For Input and Output AC Power or DC Input and DC Output Power Ports:

The EUT is connected to the power mains through a coupling device that directly couples the Surge interference signal.

The Surge noise shall be applied synchronized to the voltage phase at 0°, 90°, 180°, 270° and the peak value of the AC voltage wave. (5 Positive and 5 Negative)

Each of line-earth and line-line is impressed with a sequence of five surge voltages with interval of 1 minute.

10.5 TEST RESULT

Model: SX250-25

Temperature: 25 °C , Humidity: 45 % RH

Phase/Polarity/Mode/Result			0	90	180	270
Signal Line 1 KV	+	Line to Neutral	/	/	/	/
	-		/	/	/	/
1 KV	+	Line to Neutral	A	A	A	A
	-		A	A	A	A
2 KV	+	Line to Ground	A	A	A	A
	-		A	A	A	A
	+	Neutral to Ground	A	A	A	A
	-		A	A	A	A

Performance Criteria:

- A) Normal performance within the specification;
 - B) Temporary degradation or less of function of performance which is self recoverable;
 - C) Temporary degradation or less of function or perform. Which requires. operate intervention or system reset;
 - D) Degradation or loss of function which is not recoverable due to damage of equipment (components) or software, or loss of data;
- "/" : no test.

Final Result: **PASSED**

Remark:

Photos of test configuration please refer to appendix 1.



11. IMMUNITY TEST TO CS CONDUCTED DISTURBANCE (CS)

11.1 TEST SETUP

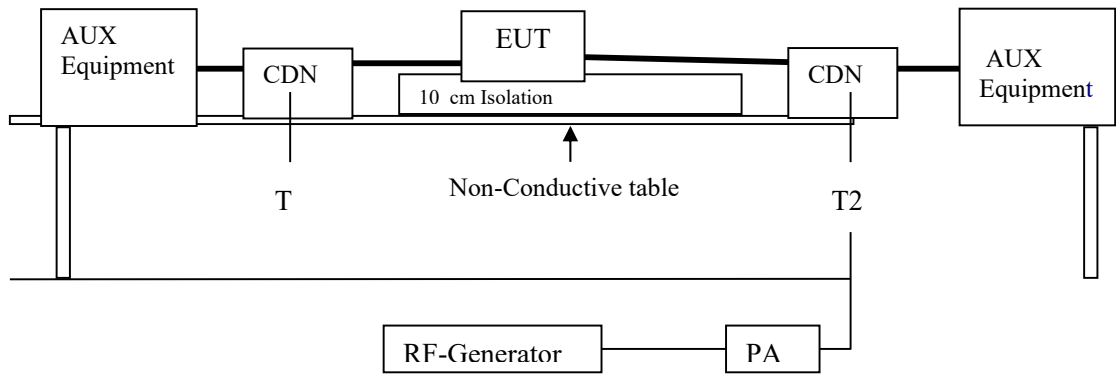

11.2 TEST PROCEDURE

According To IEC 61000-4-6

According To EN 55035

(Please refer to Page 4 for dated references which are related to the standard as mentioned above)

11.3 TEST LEVEL

Item	Test Specification	Unit	Performance Criteria
Ports for Signal Lines			
Radio-Frequency	0.15 ~ 80	MHz	A
Common Mode	3	V (rms, Unmodulated)	
Amplitude Modulated	80	%AM (1 KHz)	
	150	Source Impedance	
Ac Input and AC Output and DC Input and DC output Ports and Functional Earth Ports			
Radio-Frequency	0.15 ~ 80	MHz	
Common Mode	3	V (rms, Unmodulated)	A
Amplitude Modulated	80	%AM (1 KHz)	
	150	Source Impedance	



11.4 TEST PROCEDURE

The EUT are placed on a table which is 0.8 meter height and a ground reference plane on the table, the EUT are placed upon table and use 10cm insulation between the EUT and ground reference plane.

For AC Input and AC Output Power or DC Input and DC Output Power Ports

The EUT is connected to the power mains through a coupling and decoupling networks for Power supply lines. It also directly couples the disturbance signal into EUT.

Use CDN-M2 for two wires or CDN-M3 for three wires.

For Signal Lines and Control Lines Test:

The disturbance signal is through a coupling and decoupling networks (CDN) or EM-clamp which is to couple the signal and control lines of the EUT.

All scanning frequencies conditions are as following:

Condition of Test	Remarks
IEC 61000-4-6	
1. Field Strength	3 V; Level 2
2. Radiated Signal	AM 80% modulated with 1 KHz
3. Scanning Frequencies	0.15 MHz ~ 80 MHz
4. Dwell Time	3 seconds
5. Frequency step size Δf	1%
6. The rate of swept of frequency	1.5×10^{-3} decades/s

11.5 TEST RESULT

Model: SX250-25

Temperature: 25 °C , Humidity: 45 % RH

TEST Specification	Unit	Performance Criteria
0.15 - 80	MHz	A
3	V	
80	% AM (1 KHz)	

Performance Criteria:

- A) Normal performance within the specification;
- B) Temporary degradation or less of function of performance which is self recoverable;
- C) Temporary degradation or less of function or perform. Which requires. operate intervention or system reset;
- D) Degradation or loss of function which is not recoverable due to damage of equipment (components) or software, or loss of data;

"/" : no test.



Final Result: **PASSED**

Remark:

Photos of test configuration please refer to appendix 1.



12. POWER FREQUENCY MAGNETIC FIELD (MAGNETIC)

12.1 TEST SETUP

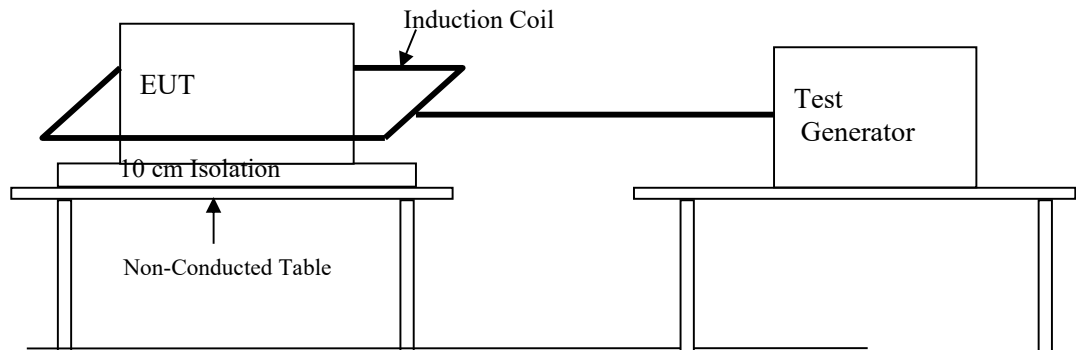

12.2 TEST STANDARD

According To IEC 61000-4-8

According To EN 55035

(Please refer to Page 4 for dated references which are related to the standard as mentioned above)

12.3 TEST LEVEL

Item	Test Specification	Unit	Performance Criteria
Power-Frequency	50	Hz	A
Magnetic Field	1	A/m	

12.4 TEST PROCEDURE

The EUT and its load are placed on a table that is 0.8 meter above the metal ground plane dimension is at least 1 meter x 1 meter. The test magnetic field shall be placed at least than 3 meter distance from the induction coil.

The test magnetic field shall be applied by the immersion method to the EUT. The induction coil shall be rotated by 90° in order to expose the EUT to the test field with different orientation (X, Y, Z orientation).



12.5 TEST RESULT

Model: SX250-25

Temperature: 25 °C , Humidity: 45 % RH

Environmental Phenomena	Test Specification	Units	Performance Criteria
Magnetic Field	1	A/m	A

Performance Criteria:

- A) Normal performance within the specification;
 - B) Temporary degradation or less of function of performance which is self recoverable;
 - C) Temporary degradation or less of function or perform. Which requires. operate intervention or system reset;
 - D) Degradation or loss of function which is not recoverable due to damage of equipment (components) or software, or loss of data;
- “/” : no test.

Final Result: **PASSED**

Remark:

Photos of test configuration please refer to appendix 1.



13. VOLTAGE DIPS AND INTERRUPTION MEASUREMENT

13.1 TEST SETUP

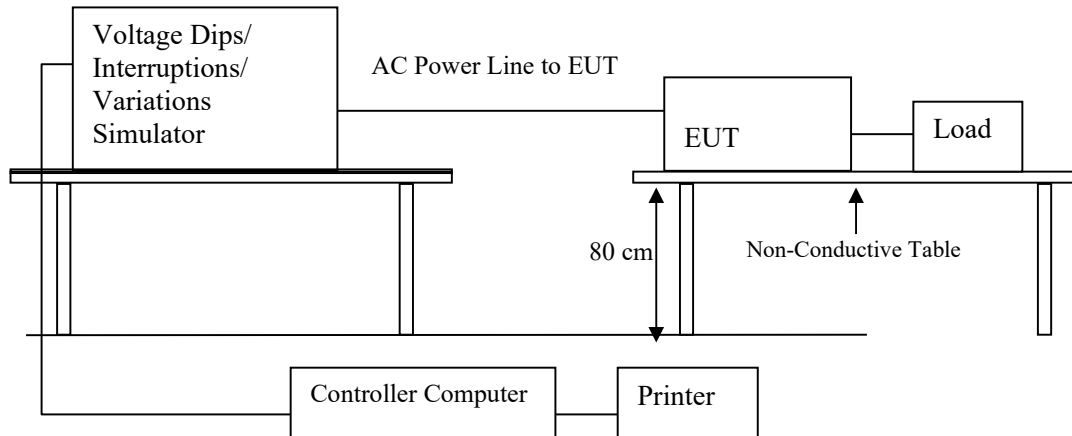

13.2 TEST PROCEDURE

According To IEC 61000-4-11

According To EN 55035

(Please refer to Page 4 for dated references which are related to the standard as mentioned above)



13.3 TEST LEVEL

Class ^a	Test level and durations for voltage dips				
Class 1	Case-by-case according to the equipment requirements				
Class 2	0 % during 1/2 cycle	0 % during 1 cycle	70 % during 25/30 ^c cycles		
Class 3	0 % during 1/2 cycle	0 % during 1 cycle	40 % during 10/12 ^c cycles	70 % during 25/30 ^c cycles	80 % during 250/300 ^c cycles
Class X ^b	X	X	X	X	X

a: Classes as per IEC 61000-2-4.
b: To be defined by product committee. For equipment connected directly or indirectly to the public network, the levels must not be less severe than Class 2.
c: "25/30 cycles" means "25 cycles for 50 Hz test" and "30 cycles for 60 Hz tet".

Class ^a	Test level and durations for short interruptions (t _s) (50Hz / 60Hz)
Class 1	Case-by-case according to the equipment requirements
Class 2	0 % during 250/300 ^c cycles
Class 3	0 % during 250/300 ^c cycles
Class X ^b	X

a: Classes as per IEC 61000-2-4.
b: To be defined by product committee. For equipment connected directly or indirectly to the public network, the levels must not be less severe than Class 2.
c: "250/300 cycles" means "250 cycles for 50 Hz test" and "300 cycles for 60 Hz test".

13.4 TEST PROCEDURE

The EUT and its load are placed on a wooden table which is 0.8 meter above a metal ground plane which dimension is 1 meter x 1 meter, the thickness is 0.65mm. It projected beyond the EUT by at least 0.1 meter on all sides. The power cord shall be used the shortest power cord as specified by the manufacturer.

For Voltage Dips / Interruption Test:

The EUT is connected to the power mains through a coupling device that directly couples to the Voltage Dips and Interruption Generator.

The EUT shall be tested for 30% voltage dips of supplied voltage and duration time is 10ms, for 60% voltage dips of supplied voltage and duration time is 100ms with a sequence of three voltage dips with intervals of 10 seconds, and for 95% voltage interruption of supplied voltage and the duration time is 5000ms with a sequence of three voltage interruptions with intervals of 10 seconds.

Voltage phase shifting are shall occur at 0°, 45°, 90°, 135°, 180°, 225°, 270°, 315° of the voltage.



13.5 TEST RESULT

Model: SX250-25

Temperature: 25 °C , Humidity: 45 % RH

Voltage Dips	Test Level % U _T	Reduction (%)	Duration	Performance Criteria
	<5	>95	0.5 (periods)	B
	70	30	25 (periods)	C

Voltage Dips	Test Level % U _T	Reduction (%)	Duration	Performance Criteria
	<5	>95	250(periods) 5000 ms	C

Performance Criteria:

- A) Normal performance within the specification;
 - B) Temporary degradation or less of function of performance which is self recoverable;
 - C) Temporary degradation or less of function or perform. Which requires. operate intervention or system reset;
 - D) Degradation or loss of function which is not recoverable due to damage of equipment (components) or software, or loss of data;
- "/" : no test.

Final Result: **PASSED**

Remark:

Please refer to appendix 1.



14. PERFORMANCE CRITERIA

- A. The apparatus shall continue to operate as intended during and after the test. No degradation of performance or loss of function is allowed below a performance level specified by the manufacturer, when the apparatus is used as intended.
- B. The apparatus shall continue to operate as intended after the test. No degradation of performance or loss of function is allowed below a performance level specified by the manufacturer, when the apparatus is used as intended. The performance level may be replaced by a permissible loss of performance. During the test, degradation of performance is however allowed.
- C. Temporary loss of function is allowed, provided the function is self-recoverable or can be restored by the operation of the controls.



15. MEASUREMENT UNCERTAINTY

Measurement Item	Measurement Frequency	Polarization	Uncertainty
Conducted Emission	9 kHz ~ 30 MHz	LINE/NEUTRAL	3.54 dB
Radiated Emission	Below 1GHz	Horizontal	2.81 dB
		Vertical	4.01 dB
	Above 1GHz	Horizontal	4.64 dB
		Vertical	5.16 dB



APPENDIX 1 PHOTOS OF TEST CONFIGURATION

Photograph – Conducted Emission Test Setup

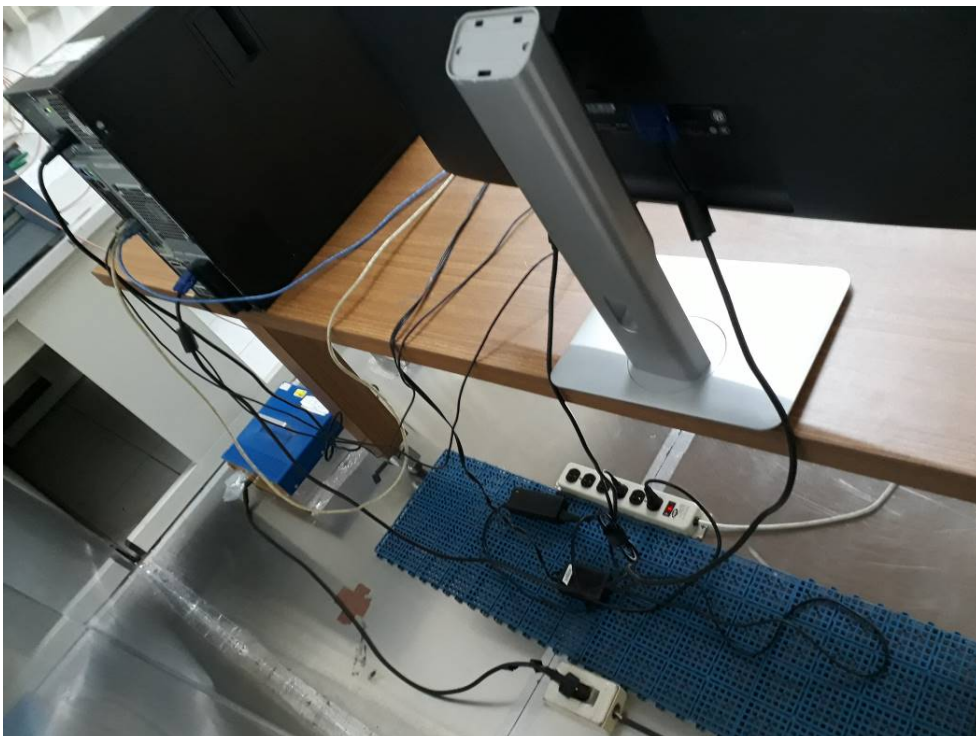



Photograph – Radiated Emission Test Setup





Photograph –Harmonics & Flicker Test Setup



Photograph –ESD Test Setup

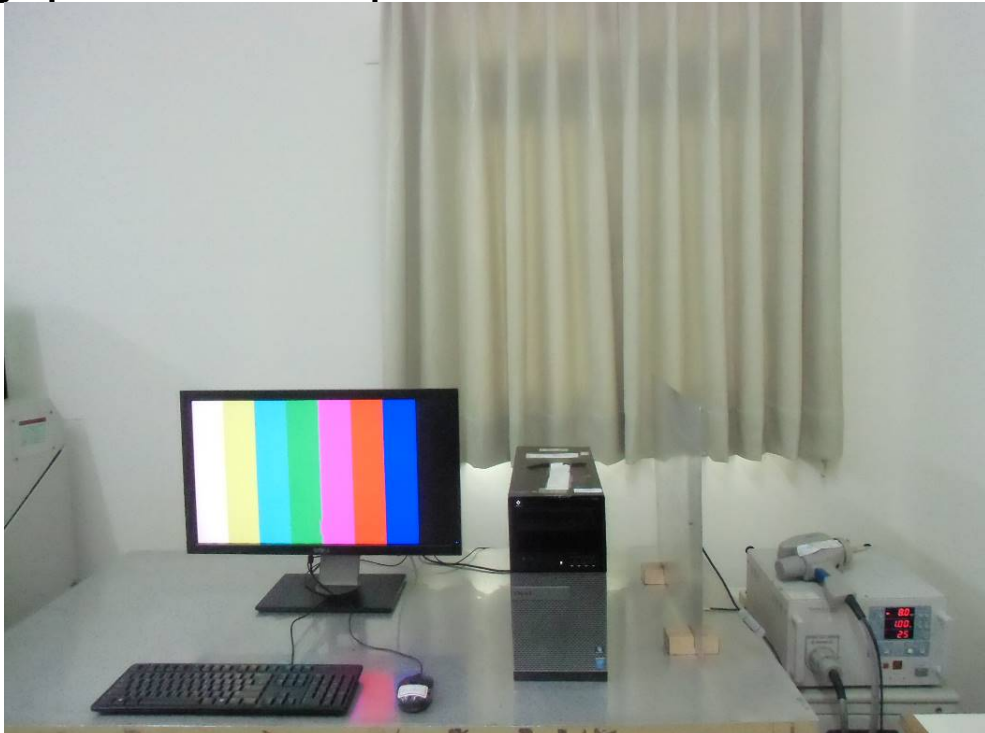



Photograph –RS Test Setup



Photograph –Surge & EFT Test Setup





Photograph –CS Test Setup

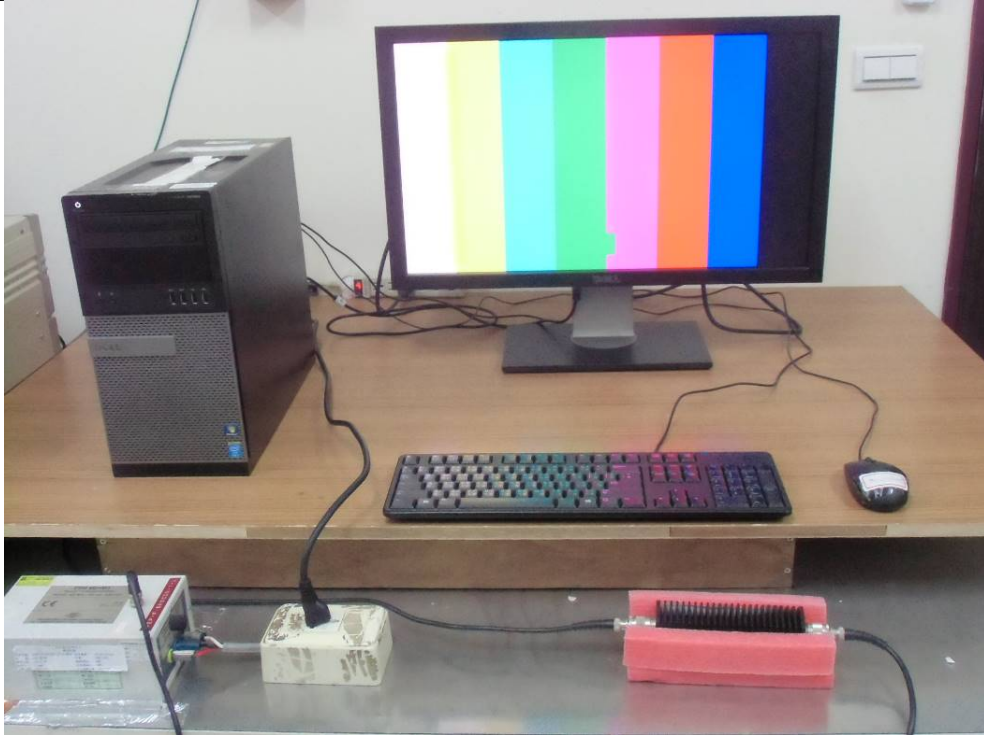

Photograph –PFMF Test Setup





Photograph –DIPS Test Setup





APPENDIX 2 TEST DATA

Test Data – Conducted Emission

Phase: L

Data: 1

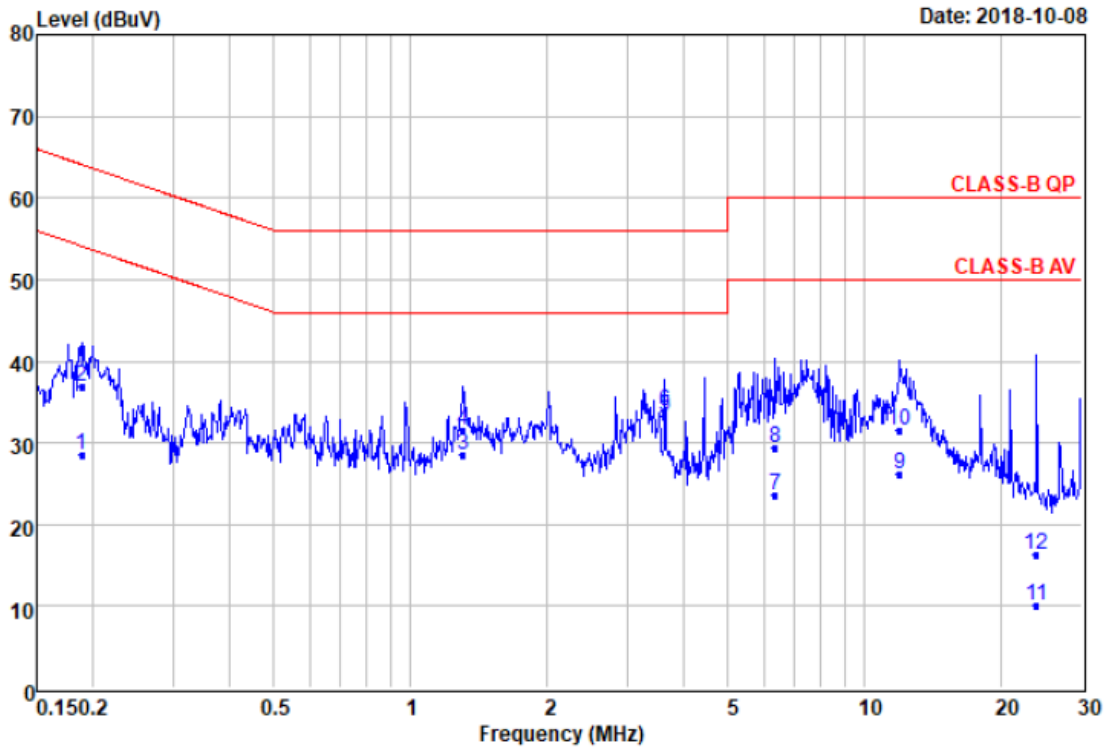

Remarks

: Factor=Insrtion loss+Cable loss

	Read	Over	Limit			
Freq	Level	Level	Factor	Limit	Line	Remark
MHz	dBuV	dBuV	dB	dB	dBuV	
1	0.19	18.50	28.61	10.11	-25.50	54.11 Average
2	0.19	26.70	36.81	10.11	-27.30	64.11 QP
3	1.30	18.40	28.58	10.18	-17.42	46.00 Average
4	1.30	21.40	31.58	10.18	-24.42	56.00 QP
5 @	3.62	22.90	33.17	10.27	-12.83	46.00 Average
6	3.62	23.70	33.97	10.27	-22.03	56.00 QP
7	6.35	13.20	23.56	10.36	-26.44	50.00 Average
8	6.35	19.10	29.46	10.36	-30.54	60.00 QP
9	11.93	15.69	26.19	10.50	-23.81	50.00 Average
10	11.93	20.99	31.49	10.50	-28.51	60.00 QP
11	23.89	-0.70	10.10	10.80	-39.90	50.00 Average
12	23.89	5.50	16.30	10.80	-43.70	60.00 QP



Phase: N

Data: 2

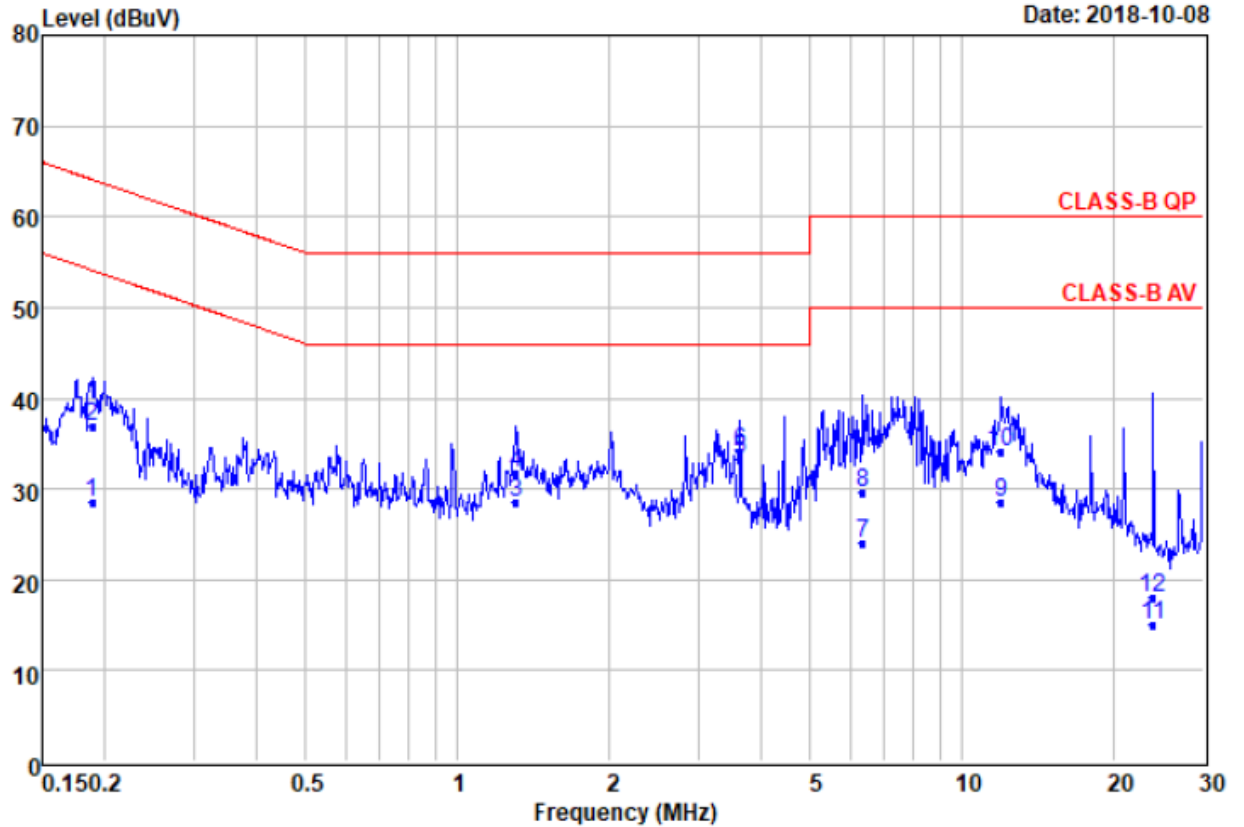

Remarks

: Factor=Insrtion loss+Cable loss

	Freq	Read Level	Level	Factor	Over Limit	Limit Line	Remark
	MHz	dBuV	dBuV	dB	dB	dBuV	
1	0.19	18.50	28.60	10.10	-25.51	54.11	Average
2	0.19	26.80	36.90	10.10	-27.21	64.11	QP
3	1.30	18.40	28.57	10.17	-17.43	46.00	Average
4	1.30	21.60	31.77	10.17	-24.23	56.00	QP
5 @	3.62	22.89	33.15	10.26	-12.85	46.00	Average
6	3.62	23.89	34.15	10.26	-21.85	56.00	QP
7	6.35	13.60	23.94	10.34	-26.06	50.00	Average
8	6.35	19.20	29.54	10.34	-30.46	60.00	QP
9	11.93	18.00	28.47	10.47	-21.53	50.00	Average
10	11.93	23.60	34.07	10.47	-25.93	60.00	QP
11	23.89	4.21	14.91	10.70	-35.09	50.00	Average
12	23.89	7.41	18.11	10.70	-41.89	60.00	QP



Test Data – Radiated Emission-Below 1GHz

Polarization: Horizontal

Data: 1

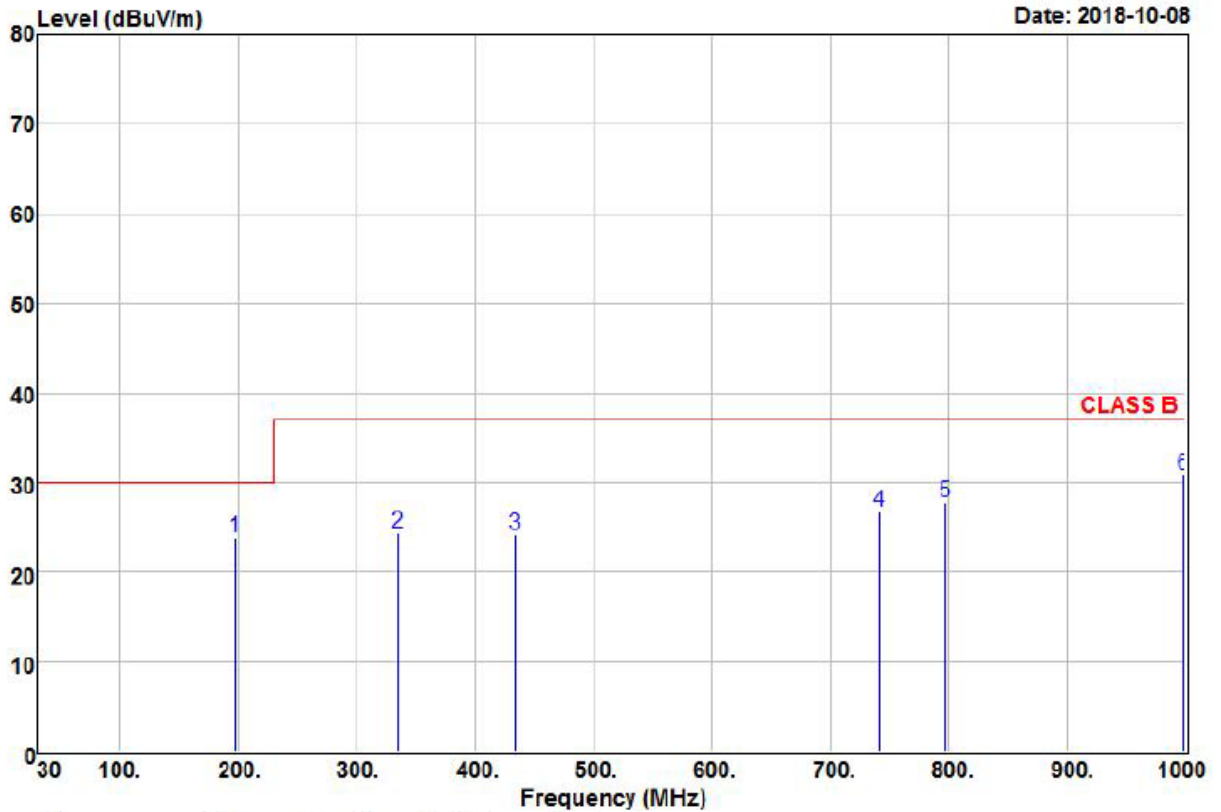

Remarks: : 1.Result=Read Value+Factor
: 2.Factor=Antenna Factor+Cable loss-
: Amplifier Factor

	Freq	Read Level	Factor	Level	Over Limit	Limit	Remark
	MHz	dBuV	dB/m	dBuV/m	dB	dBuV/m	
1 @	197.81	43.33	-19.44	23.89	-6.11	30.00	QP
2	335.55	37.57	-13.29	24.28	-12.72	37.00	QP
3	433.52	35.16	-11.00	24.16	-12.84	37.00	QP
4	741.01	33.44	-6.76	26.68	-10.32	37.00	QP
5	797.27	33.58	-5.86	27.72	-9.28	37.00	QP
6	999.03	32.93	-2.13	30.80	-6.20	37.00	QP



Polarization: Vertical

Data: 2

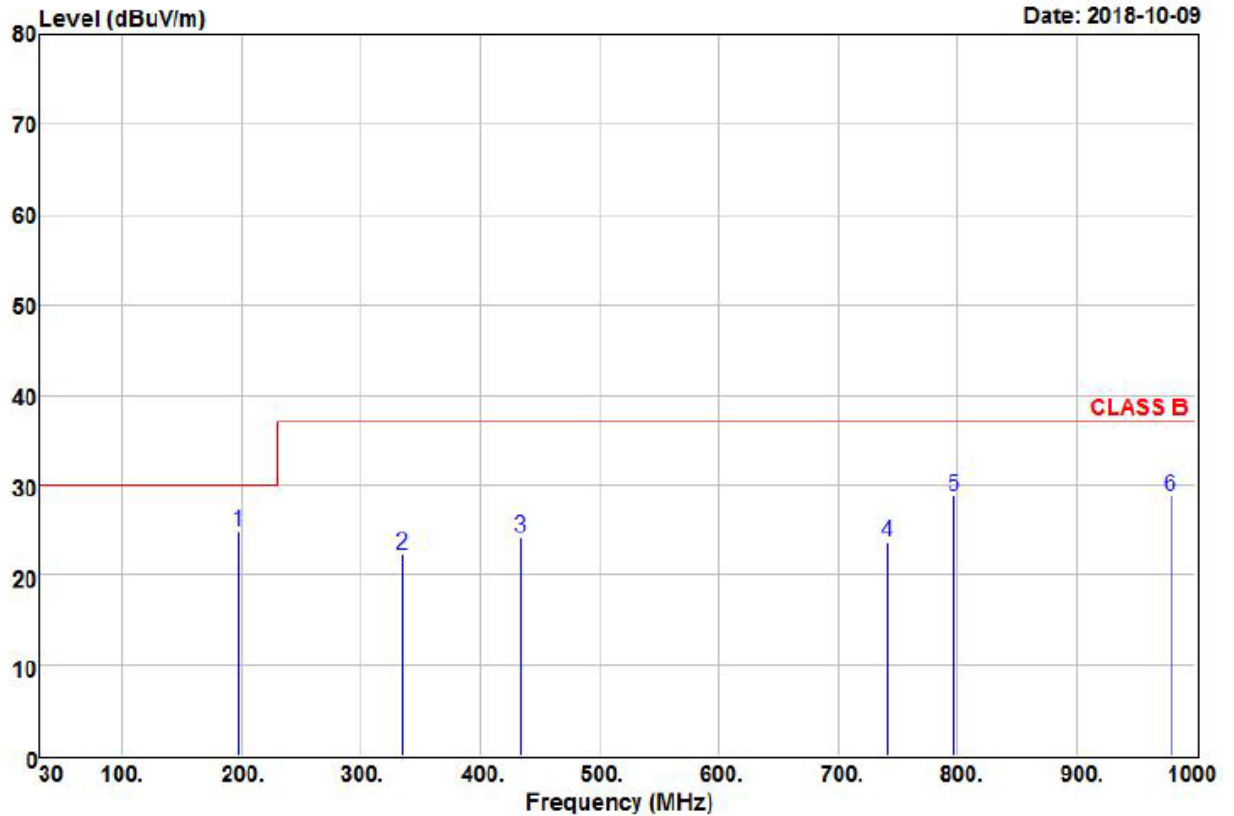

Remarks: : 1.Result=Read Value+Factor
: 2.Factor=Antenna Factor+Cable loss-
: Amplifier Factor

	Read	Over	Limit			
Freq	Level	Factor	Level	Limit	Line	Remark
MHz	dBuV	dB/m	dBuV/m	dB	dBuV/m	
1 @	197.81	44.33	-19.44	24.89	-5.11	30.00 QP
2	335.55	35.57	-13.29	22.28	-14.72	37.00 QP
3	433.52	35.16	-11.00	24.16	-12.84	37.00 QP
4	741.01	30.44	-6.76	23.68	-13.32	37.00 QP
5	797.27	34.58	-5.86	28.72	-8.28	37.00 QP
6	979.03	30.86	-2.06	28.80	-8.20	37.00 QP



Test Data – Radiated Emission-Above 1GHz(1-6G)

Polarization: Horizontal

Data: 1

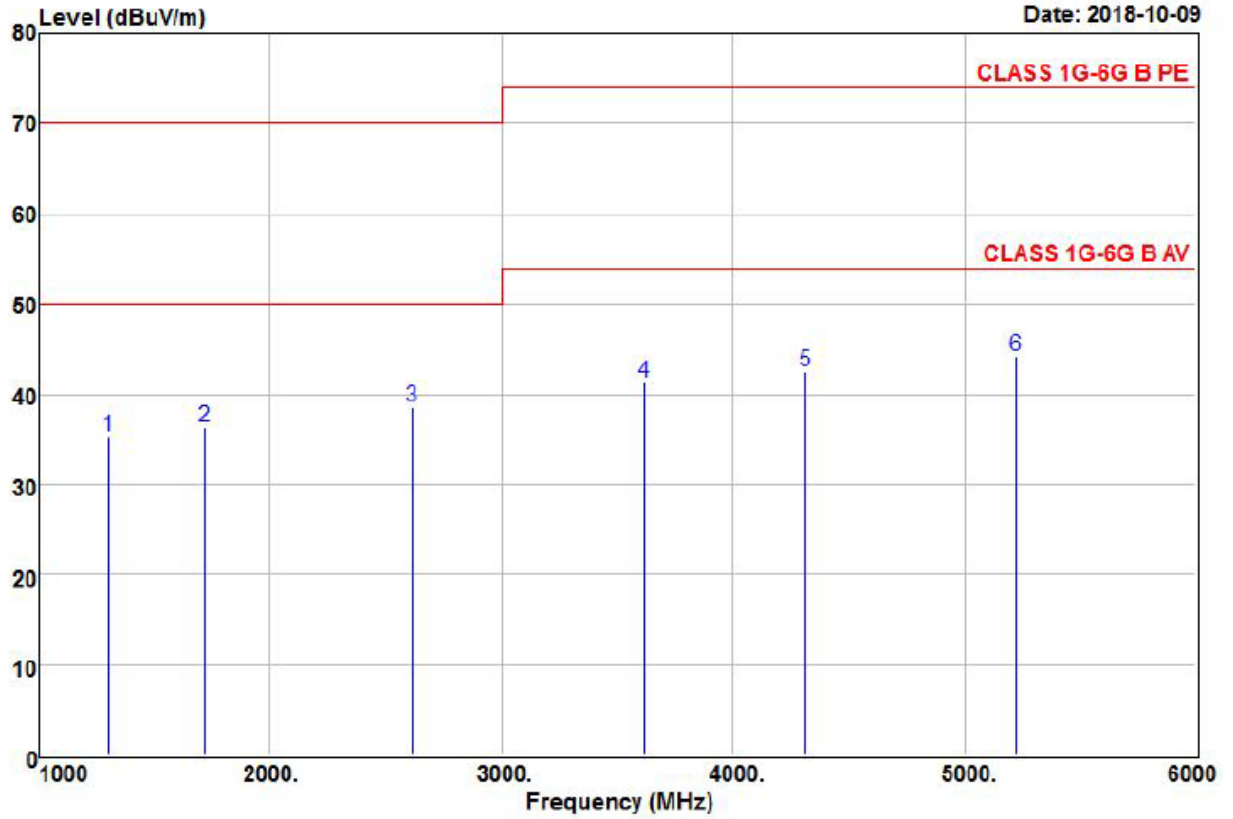

Remarks: : 1.Result=Read Value+Factor
: 2.Factor=Antenna Factor+Cable loss-
: Amplifier Factor

	Read	Over	Limit			
Freq	Level	Factor	Level	Limit	Line	Remark
MHz	dBuV	dB/m	dBuV/m	dB	dBuV/m	
1	1300.00	54.18	-18.84	35.34	-34.66	70.00 Peak
2	1717.00	52.87	-16.61	36.26	-33.74	70.00 Peak
3	2616.00	50.71	-12.16	38.55	-31.45	70.00 Peak
4	3616.00	50.39	-9.17	41.22	-32.78	74.00 Peak
5	4316.00	49.56	-7.01	42.55	-31.45	74.00 Peak
6 @	5226.00	48.58	-4.32	44.26	-29.74	74.00 Peak



Polarization: Vertical

Data: 2

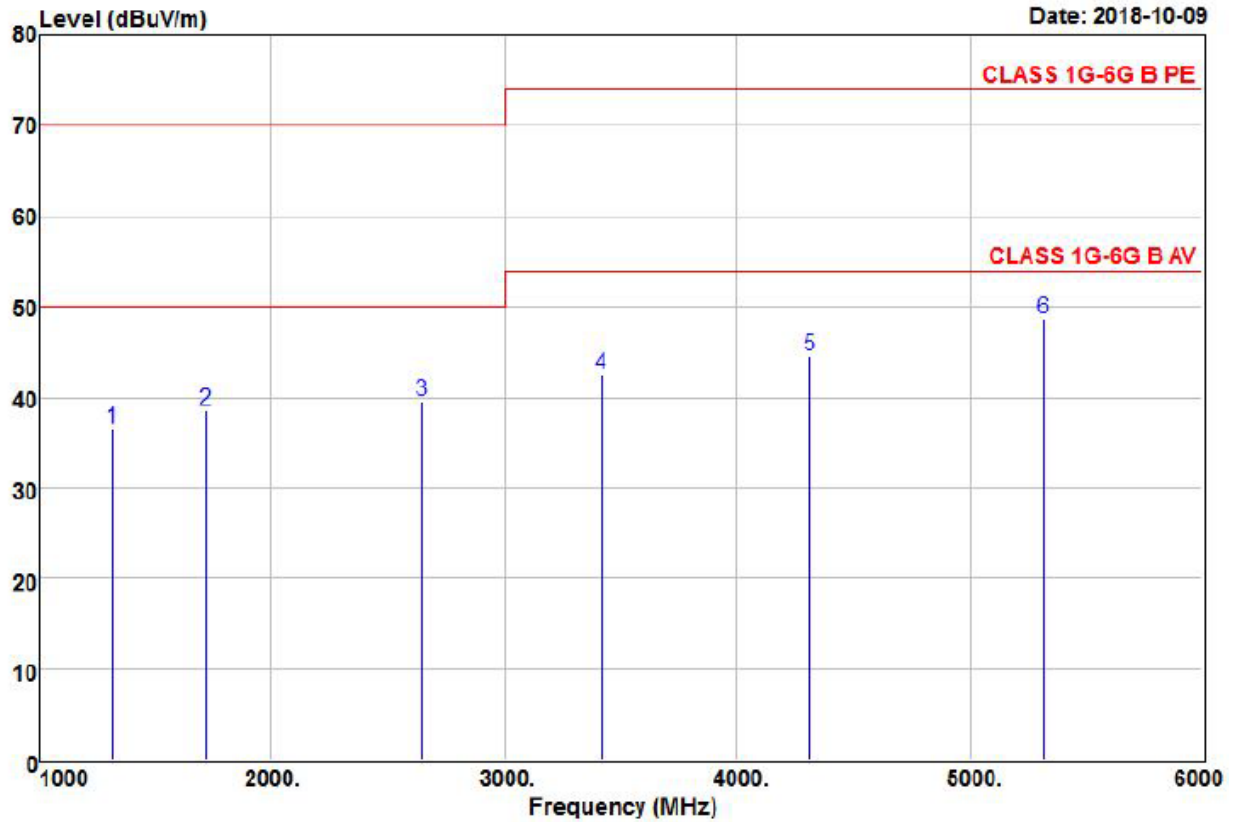

Remarks: : 1.Result=Read Value+Factor
: 2.Factor=Antenna Factor+Cable loss-
: Amplifier Factor

	Freq	Read Level	Factor	Level	Over Limit	Limit Line	Remark
	MHz	dBuV	dB/m	dBuV/m	dB	dBuV/m	
1	1312.00	55.22	-18.80	36.42	-33.58	70.00	Peak
2	1715.00	55.19	-16.63	38.56	-31.44	70.00	Peak
3	2644.00	51.71	-12.09	39.62	-30.38	70.00	Peak
4	3413.00	52.35	-9.80	42.55	-31.45	74.00	Peak
5	4316.00	51.57	-7.01	44.56	-29.44	74.00	Peak
6 @	5316.00	52.78	-4.19	48.59	-25.41	74.00	Peak



Harmonics

EMC PARTNER AG , Laufen

Date : 2018/10/9 上午 11:52 V4.22

File :

Operator
Unit
Serial Number

Urms = 224.2V Freq = 49.922 Range: 2 A
Irms = 0.226A Ipk = 0.443A cf = 1.965
P = 37.30W S = 50.58VA pf = 0.738
THDi = 17.1 % THDu = 1.30 % Class A

Test completed, Result: PASSED

Order	Freq. [Hz]	Iavg [A]	Irms [A]	Imax [A]	Limit	Status
1	50	0.2298	0.2233	0.3131		
2	100	0.0000	0.0024	0.0050	1.0800	
3	150	0.0259	0.0253	0.0343	2.3000	
4	200	0.0000	0.0017	0.0029	0.4300	
5	250	0.0157	0.0149	0.0227	1.1400	
6	300	0.0000	0.0013	0.0017	0.3000	
7	350	0.0102	0.0104	0.0133	0.7700	
8	400	0.0000	0.0027	0.0038	0.2300	
9	450	0.0099	0.0103	0.0133	0.4000	
10	500	0.0000	0.0011	0.0029	0.1840	
11	550	0.0100	0.0103	0.0132	0.3300	
12	600	0.0000	0.0013	0.0016	0.1533	
13	650	0.0084	0.0083	0.0118	0.2100	
14	700	0.0000	0.0015	0.0021	0.1314	
15	750	0.0050	0.0051	0.0101	0.1500	
16	800	0.0000	0.0007	0.0027	0.1150	
17	850	0.0059	0.0057	0.0090	0.1324	
18	900	0.0000	0.0021	0.0032	0.1022	
19	950	0.0042	0.0051	0.0072	0.1184	
20	1000	0.0000	0.0024	0.0035	0.0920	
21	1050	0.0000	0.0029	0.0051	0.1071	
22	1100	0.0000	0.0010	0.0018	0.0836	
23	1150	0.0000	0.0026	0.0038	0.0978	
24	1200	0.0000	0.0011	0.0013	0.0767	
25	1250	0.0000	0.0031	0.0042	0.0900	
26	1300	0.0000	0.0006	0.0017	0.0708	
27	1350	0.0000	0.0024	0.0043	0.0833	
28	1400	0.0000	0.0020	0.0024	0.0657	



29	1450	0.0000	0.0012	0.0026	0.0776
30	1500	0.0000	0.0032	0.0034	0.0613
31	1550	0.0000	0.0007	0.0018	0.0726
32	1600	0.0000	0.0016	0.0023	0.0575
33	1650	0.0000	0.0007	0.0026	0.0682
34	1700	0.0000	0.0013	0.0017	0.0541
35	1750	0.0000	0.0006	0.0035	0.0643
36	1800	0.0000	0.0011	0.0021	0.0511
37	1850	0.0000	0.0011	0.0035	0.0608
38	1900	0.0000	0.0026	0.0037	0.0484
39	1950	0.0000	0.0010	0.0027	0.0577
40	2000	0.0000	0.0037	0.0042	0.0460

Important:
- 100% of time voltage "out of Spec"



Voltage on EUT
Current into EUT

Urms = 224.2 V P = 37.30 W
Irms = 0.226 A pf = 0.738

THC = 0.038 A

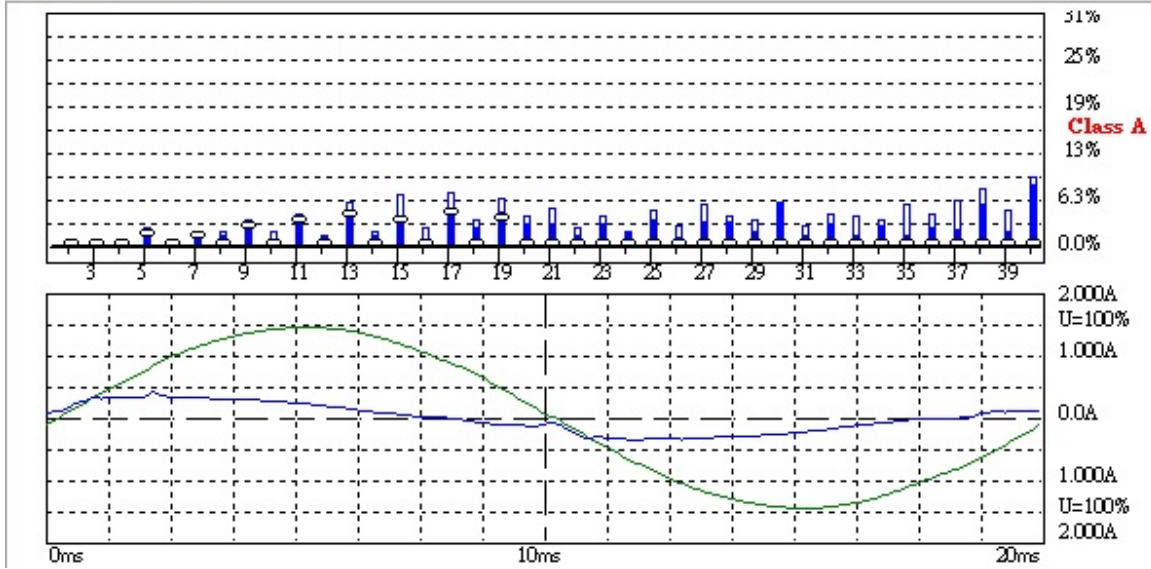



Flicker

EMC PARTNER AG , Laufen

Date : 2018/10/9 下午 12:16 V4.22

File :

Operator
Unit
Serial Number

Urms = 224.2V Freq = 49.922 Range: 2 A
Irms = 0.228A Ipk = 0.463A cf = 2.034
P = 38.58W S = 51.02VA pf = 0.756

LIN (Line Impedance Network) : L: 0.24ohm +j0.15ohm N: 0.16ohm +j0.10ohm

Limits : Plt : 0.65 Pst : 1.00
dmax : 4.00 % dc : 3.30 %
dtLim: 3.30 % dt>Lim: 200ms

Test completed, Result: PASSED

dmax
[%]
1 0.000



Cumulative Probability Function

Urms = 224.2 V P = 38.58 W d(t) : steady
Irms = 0.228 A pf = 0.756 Time: 10.1 min



Flicker Emission IEC 61000-4-15 for 230V/50Hz

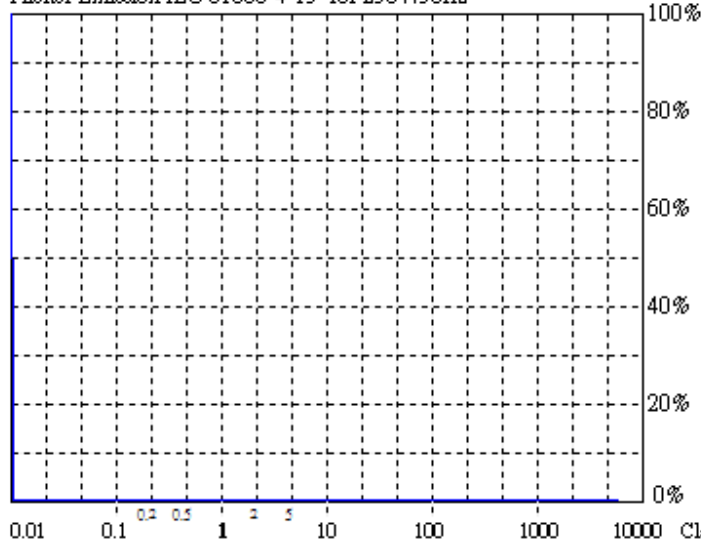

Actual Flicker (Flt): 0.00
Short-term Flicker (Pst): 0.07
Limit (Pst): 1.00
Long-term Flicker (Plt): 0.07
Limit (Plt): 0.65
Maximum Relative Volt. Change (dmax): 0.00%
Limit (dmax): 4.00%
Relative Steady-state Voltage Change (dc): 0.01%
Limit (dc): 3.00%
Tmax 3.00% (dt): 0.00ms
Limit (dt>Lim): 200ms

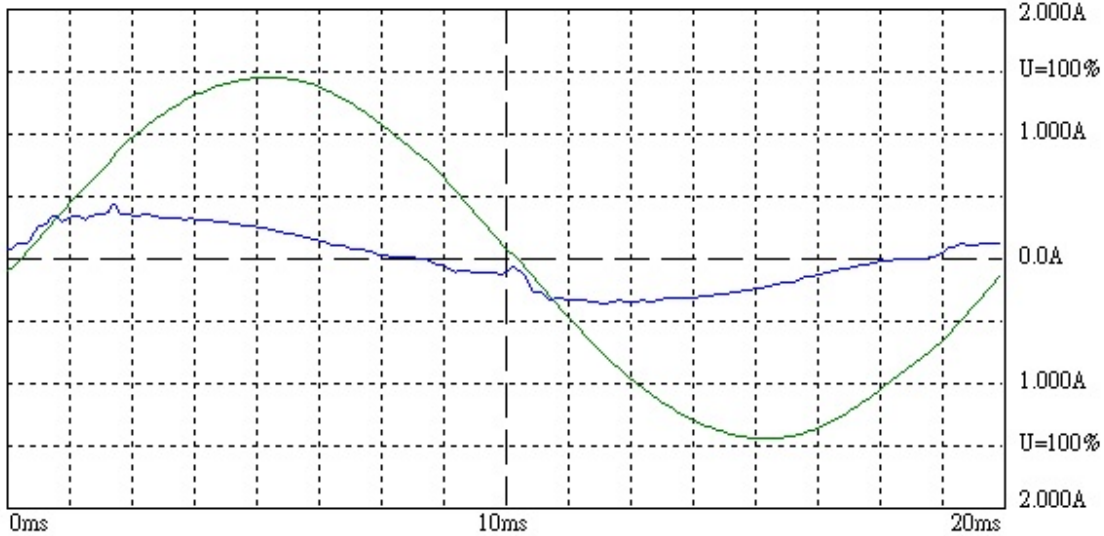



APPENDIX 3 PHOTOS OF EUT

