

DATA SHEET

119 AHT-DIN
Aluminum electrolytic capacitors
Axial High Temperature, DIN-based

Product specification
Supersedes data of 7th June 2002
File under BCcomponents, BC01

2003 Feb 25

Aluminum electrolytic capacitors

Axial High Temperature, DIN-based

119 AHT-DIN

FEATURES

- Polarized aluminum electrolytic capacitors, non-solid electrolyte
- Axial leads, cylindrical aluminium case, insulated with a blue sleeve
- Mounting ring version not insulated
- Taped versions up to case $\varnothing 15 \times 30$ mm available for automatic insertion
- Charge and discharge proof
- Extra long useful life: up to 8000 hours at 125 °C, high stability, high reliability
- Extended temperature range: 125 °C (usable up to 150 °C)
- High ripple current capability.

APPLICATIONS

- Military, industrial control, EDP and telecommunication
- Smoothing, filtering, buffering in SMPS; coupling, decoupling
- For use where low mounting height is important; vibration and shock resistant.

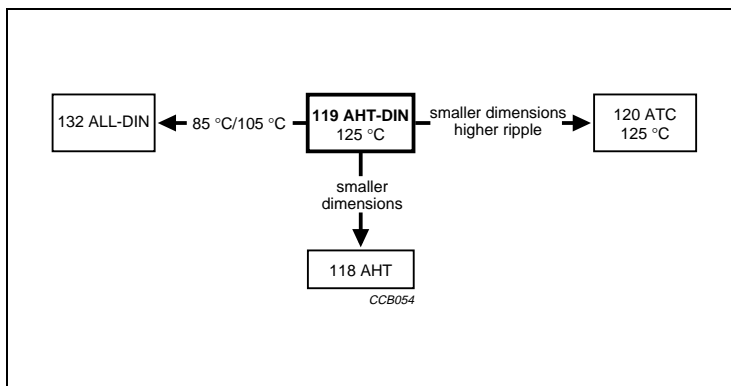
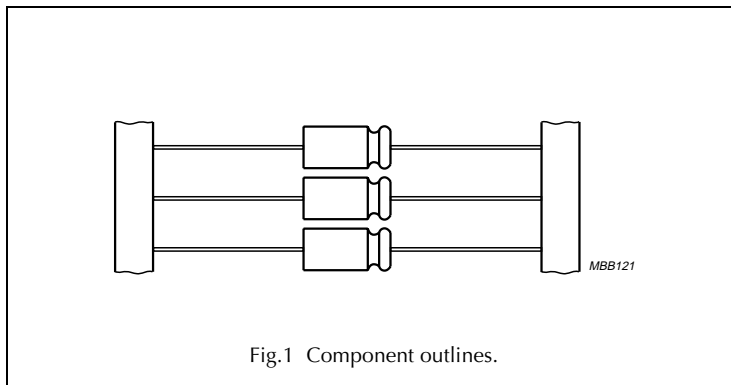

QUICK REFERENCE DATA

DESCRIPTION	VALUE	
Case sizes ($\varnothing D_{nom} \times L_{nom}$ in mm)	6.5 × 18 to 10 × 25	10 × 30 to 21 × 38
Rated capacitance range, C_R	4.7 to 4700 μ F	
Tolerance on C_R	-10/+50%	
Rated voltage range, U_R	10 to 200 V	
Category temperature range	-55 to +125 °C	
Endurance test at 150 °C	500 hours	500 hours
Endurance test at 125 °C	2 000 hours	4 000 hours
Useful life at 125 °C	4 000 hours	8 000 hours
Useful life at 40 °C, 1.8 I_R applied	500 000 hours	1 000 000 hours
Shelf life at 0 V, 125 °C: $U_R = 10$ to 63 V $U_R = 100$ and 200 V	500 hours 100 hours	
Based on sectional specification	IEC 60384-4/EN130300	
Climatic category IEC 60068	55/125/56	

Aluminum electrolytic capacitors

Axial High Temperature, DIN-based

119 AHT-DIN

Selection chart for C_R , U_R and relevant nominal case sizes ($\varnothing D \times L$ in mm)

Preferred types in **bold**.

C_R (μF)	U_R (V)						
	10	16	25	40	63	100	200
4.7	–	–	–	–	–	6.5 × 18	10 × 18
10	–	–	–	–	6.5 × 18	8 × 18	10 × 25
22	–	–	6.5 × 18	–	8 × 18	10 × 18	–
47	–	6.5 × 18	–	8 × 18	10 × 18	10 × 25	–
	–	–	–	–	–	10 × 30	–
68	–	–	–	–	10 × 30	12.5 × 30	–
100	6.5 × 18	8 × 18	10 × 18	10 × 25	10 × 30	15 × 30	–
150	–	–	–	12.5 × 30	15 × 30	15 × 30	–
220	10 × 18	10 × 25	10 × 25	12.5 × 30	15 × 30	18 × 30	–
	–	–	12.5 × 30	–	–	–	–
330	–	12.5 × 30	12.5 × 30	15 × 30	18 × 30	18 × 38	–
470	10 × 25	12.5 × 30	12.5 × 30	15 × 30	18 × 38	21 × 38	–
	12.5 × 30	–	–	–	–	–	–
680	12.5 × 30	15 × 30	18 × 30	18 × 30	21 × 38	–	–
1000	15 × 30	15 × 30	18 × 30	18 × 38	21 × 38	–	–
1500	18 × 30	18 × 30	18 × 38	21 × 38	–	–	–
2200	18 × 30	18 × 38	21 × 38	21 × 38	–	–	–
3300	18 × 38	21 × 38	–	–	–	–	–
4700	21 × 38	21 × 38	–	–	–	–	–

MARKING

The capacitors are marked (where possible) with the following information:

- Rated capacitance (in μF)
- Tolerance on rated capacitance, code letter in accordance with "IEC 60062"
- Rated voltage (in V) at 125 °C and 85 °C
- Group number (119)
- Name of manufacturer
- Date code, in accordance with "IEC 60062"
- Code indicating factory of origin
- Band to indicate the negative terminal
- '+' sign to identify the positive terminal.

Aluminum electrolytic capacitors

Axial High Temperature, DIN-based

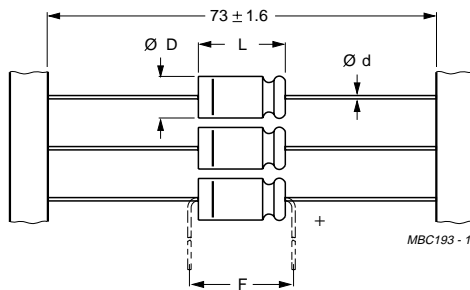
119 AHT-DIN
MECHANICAL DATA, AVAILABLE FORMS AND PACKAGING QUANTITIES

Dimensions in mm.

Form BR: Taped on reel,
case $\varnothing D \times L = 6.5 \times 18$ to 15×30 mm.

Form BA: Taped in box (ammopack),
case $\varnothing D \times L = 6.5 \times 18$ to 10×25 mm.

For dimensions see Table 1.

Tape dimensions are specified in data handbook BC01, section "Packaging".

Fig.2 Dimensional outline; Forms BA and BR.

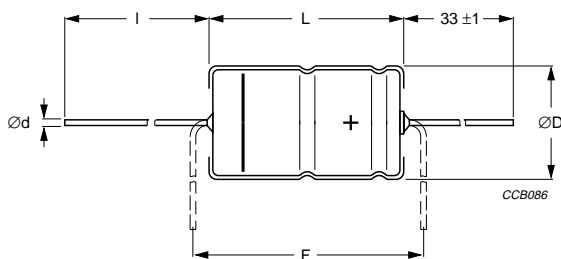

Dimensions in mm.

Form AA: Axial in box,
case $\varnothing D \times L = 10 \times 30$ to 21×38 mm.

For dimensions see Table 1.

Fig.3 Dimensional outline; Form AA.

Aluminum electrolytic capacitors

Axial High Temperature, DIN-based

119 AHT-DIN

Table 1 Axial; physical dimensions, mass and packaging quantities; see Figs 2 and 3

NOMINAL CASE SIZE ØD × L (mm)	CASE CODE	AXIAL FORM AA, BA, and BR					MASS (g)	PACKAGING QUANTITIES		
		Ød	l (mm)	ØD _{max} (mm)	L _{max} (mm)	F _{min} (mm)		FORM AA	FORM BA	FORM BR
6.5 × 18	4	0.8	–	6.9	18.5	25	≈1.3	–	1000	1000
8 × 18	5	0.8	–	8.5	18.5	25	≈1.7	–	500	500
10 × 18	6	0.8	–	10.5	18.5	25	≈2.5	–	500	500
10 × 25	7	0.8	–	10.5	25.0	30	≈3.3	–	500	500
10 × 30	00	0.8	55 ±1	10.5	30.5	35	≈4.8	340	–	500
12.5 × 30	01	0.8	55 ±1	13.0	30.5	35	≈7.4	260	–	400
15 × 30	02	0.8	55 ±1	15.5	30.5	35	≈11.7	300	–	250
18 × 30	03	0.8	55 ±1	18.5	30.5	35	≈12.9	200	–	–
18 × 38	04	0.8	34 ±1	18.5	39.0	44	≈19.0	125	–	–
21 × 38	05	0.8	34 ±1	21.5	39.0	44	≈24.0	100	–	–

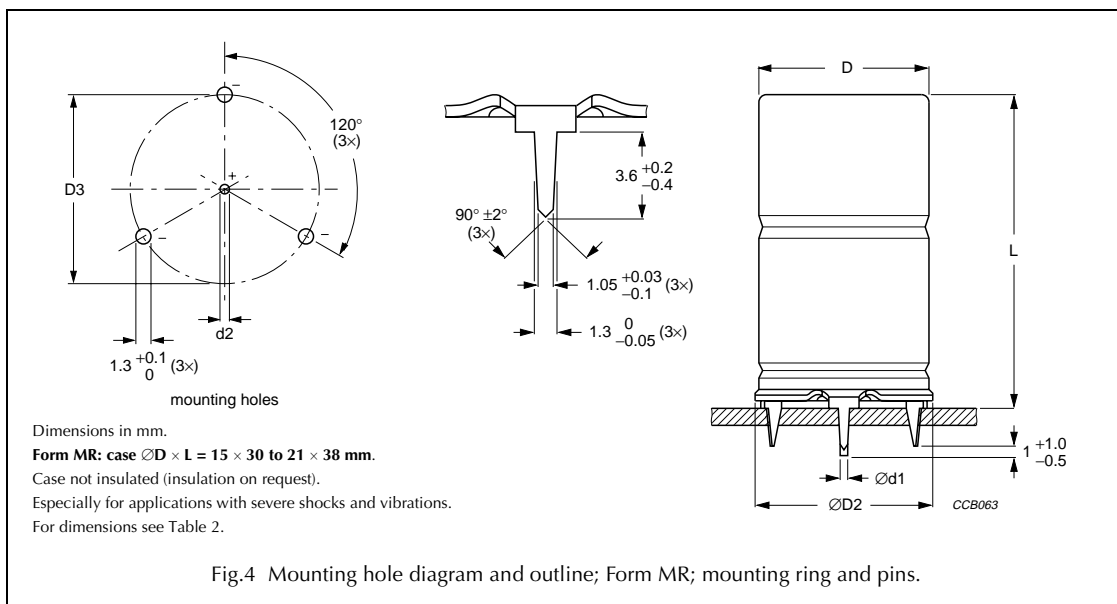

Fig.4 Mounting hole diagram and outline; Form MR; mounting ring and pins.

Table 2 Mounting ring; mass and packaging quantities; see Fig.4

NOMINAL CASE SIZE ØD × L (mm)	CASE CODE	MOUNTING RING: FORM MR						MASS (g)	PACKAGING QUANTITIES
		Ød1 (mm)	Ød2 (mm)	ØD _{max} (mm)	ØD _{2max} (mm)	D3 (mm)	L _{max} (mm)		
15 × 30	02	0.8	1.0 +0.4	15.5	17.5	16.5 ±0.2	33	≈8.6	200
18 × 30	03	0.8	1.0 +0.4	18.5	19.5	18.5 ±0.2	33	≈11.5	240
18 × 38	04	0.8	1.0 +0.4	18.5	19.5	18.5 ±0.2	42	≈14.0	100
21 × 38	05	0.8	1.0 +0.4	21.5	22.5	21.5 ±0.2	42	≈19.2	100

Aluminum electrolytic capacitors Axial High Temperature, DIN-based

119 AHT-DIN

Ordering example

Electrolytic capacitor 119 series

470 $\mu\text{F}/16\text{ V}$; $-10/+50\%$

Nominal case size: $\varnothing 12.5 \times 30\text{ mm}$; Form BR

Catalogue number: 2222 119 25471.

ELECTRICAL DATA AND ORDERING INFORMATION

Unless otherwise specified, all electrical values in Table 3 apply at $T_{\text{amb}} = 20\text{ }^{\circ}\text{C}$,

$P = 86\text{ to }106\text{ kPa}$, $\text{RH} = 45\text{ to }75\%$.

SYMBOL	DESCRIPTION
C_R	rated capacitance at 100 Hz, tolerance $-10/+50\%$
I_R	rated RMS ripple current at 100 Hz, $125\text{ }^{\circ}\text{C}$
I_{L1}	max. leakage current after 1 minute at U_R
I_{L5}	max. leakage current after 5 minutes at U_R
$\text{Tan } \delta$	max. dissipation factor at 100 Hz
ESR	equivalent series resistance at 100 Hz (calculated from $\text{tan } \delta_{\text{max}}$ and C_R)
Z	max. impedance at 10 kHz

Table 3 Electrical data and ordering Information; preferred types in **bold**

U_R (V)	C_R 100 Hz (μF)	NOMINAL CASE SIZE $\varnothing D \times L$ (mm)	CASE CODE	I_R 100 Hz 125 $^{\circ}\text{C}$ (mA)	I_{L1} 1 min (μA)	I_{L5} 5 min (μA)	$\text{Tan } \delta$ 100 Hz	ESR 100 Hz (Ω)	Z 10 kHz (Ω)	CATALOGUE NUMBER 2222			
										IN BOX FORM AA	TAPED ON REEL FORM BR	TAPED IN BOX FORM BA	MOUNTING RING FORM MR
10	100	6.5×18	4	130	10	6	0.2	3.5	2.2	–	119 24101	119 34101	–
	220	10×18	6	240	17	8.4	0.18	1.3	1.0	–	119 24221	119 34221	–
	470	10×25	7	380	32	13	0.18	0.61	0.49	–	119 90501	119 90502	–
	470	12.5×30	01	550	32	13	0.16	0.54	0.38	119 14471	119 24471	–	–
	680	12.5×30	01	640	45	18	0.20	0.47	0.38	119 14681	119 24681	–	–
	1000	15×30	02	830	64	24	0.20	0.32	0.24	119 14102	119 24102	–	119 44102
	1500	18×30	03	1100	94	34	0.22	0.23	0.17	119 14152	–	–	119 44152
	2200	18×30	03	1190	136	48	0.26	0.19	0.17	119 14222	–	–	119 44222
	3300	18×38	04	1550	202	70	0.27	0.13	0.10	119 14332	–	–	119 44332
	4700	21×38	05	1700	286	90	0.30	0.10	0.09	119 14472	–	–	119 44472
16	47	6.5×18	4	110	10	5.5	0.13	4.4	2.2	–	119 25479	119 35479	–
	100	8×18	5	170	14	7.2	0.13	2.1	1.3	–	119 25101	119 35101	–
	220	10×25	7	300	25	11	0.13	0.94	0.55	–	119 25221	119 35221	–
	330	12.5×30	01	560	36	15	0.13	0.63	0.38	119 15331	119 25331	–	–
	470	12.5×30	01	570	50	19	0.15	0.51	0.38	119 15471	119 25471	–	–

Aluminum electrolytic capacitors Axial High Temperature, DIN-based

119 AHT-DIN

U _R (V)	C _R 100 Hz (μF)	NOMINAL CASE SIZE ∅D × L (mm)	CASE CODE	I _R 100 Hz 125 °C (mA)	I _{L1} 1 min (μA)	I _{L5} 5 min (μA)	Tan δ 100 Hz	ESR 100 Hz (Ω)	Z 10 kHz (Ω)	CATALOGUE NUMBER 2222			
										IN BOX FORM AA	TAPED ON REEL FORM BR	TAPED IN BOX FORM BA	MOUNTING RING FORM MR
16	680	15 × 30	02	750	69	26	0.15	0.35	0.24	119 15681	119 25681	–	119 45681
	1000	15 × 30	02	850	100	36	0.19	0.30	0.24	119 15102	119 25102	–	119 45102
	1500	18 × 30	03	1120	148	52	0.20	0.21	0.17	119 15152	–	–	119 45152
	2200	18 × 38	04	1440	215	74	0.20	0.14	0.10	119 15222	–	–	119 45222
	3300	21 × 38	05	1650	321	110	0.22	0.11	0.09	119 15332	–	–	119 45332
	4700	21 × 38	05	1710	455	154	0.28	0.09	0.09	119 15472	–	–	119 45472
25	22	6.5 × 18	4	85	10	5.1	0.10	7.2	3.2	–	119 26229	119 36229	–
	100	10 × 18	6	210	19	9	0.10	1.6	1.0	–	119 26101	119 36101	–
	220	10 × 25	7	350	37	15	0.10	0.72	0.58	–	119 90503	119 90504	–
	220	12.5 × 30	01	500	37	15	0.09	0.65	0.38	119 16221	119 26221	–	–
	330	12.5 × 30	01	580	54	21	0.11	0.53	0.38	119 16331	119 26331	–	–
	470	12.5 × 30	01	630	75	28	0.13	0.44	0.38	119 16471	119 26471	–	–
	680	18 × 30	03	990	106	38	0.13	0.30	0.17	119 16681	–	–	119 46681
	1000	18 × 30	03	1090	154	54	0.13	0.21	0.17	119 16102	–	–	119 46102
	1500	18 × 38	04	1420	229	79	0.13	0.14	0.10	119 16152	–	–	119 46152
2200	21 × 38	05	1550	334	114	0.13	0.11	0.09	119 16222	–	–	119 46222	
40	47	8 × 18	5	150	15	7.8	0.08	2.7	1.5	–	119 27479	119 37479	–
	100	10 × 25	7	260	28	12	0.08	1.3	0.7	–	119 27101	119 37101	–
	150	12.5 × 30	01	440	40	16	0.08	0.85	0.51	119 17151	119 27151	–	–
	220	12.5 × 30	01	500	57	22	0.09	0.65	0.48	119 17221	119 27221	–	–
	330	15 × 30	02	630	83	30	0.09	0.43	0.37	119 17331	119 27331	–	119 47331
	470	15 × 30	02	720	117	42	0.12	0.41	0.37	119 17471	119 27471	–	119 47471
	680	18 × 30	03	970	167	58	0.12	0.28	0.22	119 17681	–	–	119 47681
	1000	18 × 38	04	1250	244	84	0.12	0.19	0.14	119 17102	–	–	119 47102
	1500	21 × 38	05	1410	364	124	0.14	0.15	0.12	119 17152	–	–	119 47152
2200	21 × 38	05	1550	532	180	0.18	0.13	0.11	119 17222	–	–	119 47222	

Aluminum electrolytic capacitors Axial High Temperature, DIN-based

119 AHT-DIN

U _R (V)	C _R 100 Hz (μF)	NOMINAL CASE SIZE ∅D × L (mm)	CASE CODE	I _R 100 Hz 125 °C (mA)	I _{L1} 1 min (μA)	I _{L5} 5 min (μA)	Tan δ 100 Hz	ESR 100 Hz (Ω)	Z 10 kHz (Ω)	CATALOGUE NUMBER 2222			
										IN BOX FORM AA	TAPED ON REEL FORM BR	TAPED IN BOX FORM BA	MOUNTING RING FORM MR
63	10	6.5 × 18	4	68	20	5.3	0.07	11	5.6	–	119 28109	119 38109	–
	22	8 × 18	5	110	20	6.7	0.07	5.1	2.8	–	119 28229	119 38229	–
	47	10 × 18	6	180	22	9.9	0.07	2.4	1.3	–	119 28479	119 38479	–
	68	10 × 25	7	230	30	13	0.07	1.6	1.0	–	119 90505	119 90506	–
	68	10 × 30	00	300	30	13	0.07	1.6	0.92	119 18689	119 28689	–	–
	100	10 × 30	00	360	42	17	0.08	1.3	0.75	119 18101	119 28101	–	–
	150	15 × 30	02	560	61	23	0.08	0.85	0.37	119 18151	119 28151	–	119 48151
	220	15 × 30	02	640	87	32	0.08	0.58	0.37	119 18221	119 28221	–	119 48221
	330	18 × 30	03	880	129	46	0.09	0.43	0.23	119 18331	–	–	119 48331
	470	18 × 38	04	1130	182	63	0.09	0.30	0.15	119 18471	–	–	119 48471
	680	21 × 38	05	1290	261	90	0.09	0.21	0.12	119 18681	–	–	119 48681
	1000	21 × 38	05	1430	382	130	0.10	0.16	0.11	119 18102	–	–	119 48102
100	4.7	6.5 × 18	4	44	20	10	0.08	27	10	–	119 29478	119 39478	–
	10	8 × 18	5	70	20	10	0.08	13	6.0	–	119 29109	119 39109	–
	22	10 × 18	6	112	20	10	0.08	5.8	3.5	–	119 29229	119 39229	–
	47	10 × 25	7	178	32	13	0.08	2.7	2.0	–	119 90518	119 90519	–
	47	10 × 30	00	240	32	13	0.08	2.7	2.0	119 19479	119 29479	–	–
	68	12.5 × 30	01	330	45	18	0.08	1.9	1.2	119 19689	119 29689	–	–
	100	15 × 30	02	440	64	24	0.09	1.4	0.96	119 19101	119 29101	–	119 49101
	150	15 × 30	02	520	94	34	0.10	1.1	0.78	119 19151	119 29151	–	119 49151
	220	18 × 30	03	710	136	48	0.10	0.72	0.55	119 19221	–	–	119 49221
	330	18 × 38	04	920	202	70	0.10	0.48	0.37	119 19331	–	–	119 49331
	470	21 × 38	05	1070	286	98	0.10	0.34	0.28	119 19471	–	–	119 49471
200	4.7	10 × 18	6	52	20	10	0.08	27	10	–	119 90507	119 90508	–
	10	10 × 25	7	82	20	10	0.08	13	5.0	–	119 90509	119 90511	–

Aluminum electrolytic capacitors

Axial High Temperature, DIN-based

119 AHT-DIN

Additional electrical data

PARAMETER	CONDITIONS	VALUE	
		AXIAL	MOUNTING RING
Voltage			
Surge voltage		$U_s \leq 1.15 \times U_R$	
Reverse voltage		$U_{rev} \leq 1 \text{ V}$	
Current			
Leakage current	after 1 minute: $U_R = 10 \text{ to } 40 \text{ V}$ $U_R = 63 \text{ V to } 200 \text{ V}$	$I_{L1} \leq 0.006C_R \times U_R + 4 \mu\text{A}$, or $10 \mu\text{A}$ (whichever is greater) $I_{L1} \leq 0.006C_R \times U_R + 4 \mu\text{A}$, or $20 \mu\text{A}$ (whichever is greater)	
	after 5 minutes: $U_R = 10 \text{ to } 63 \text{ V}$ $U_R = 100 \text{ and } 200 \text{ V}$	$I_{L5} \leq 0.002C_R \times U_R + 4 \mu\text{A}$ $I_{L5} \leq 0.002C_R \times U_R + 4 \mu\text{A}$, or $10 \mu\text{A}$ (whichever is greater)	
Inductance			
Equivalent series inductance (ESL)	case $\varnothing D \times L$ mm: 6.5 × 18 8 × 18 10 × 18 10 × 25 10 × 30 12.5 × 30 15 × 30 18 × 30 18 × 38 21 × 38	typ. 15 nH typ. 35 nH typ. 69 nH typ. 38 nH typ. 38 nH typ. 46 nH typ. 48 nH typ. 50 nH typ. 54 nH typ. 59 nH	– – – – – – typ. 39 nH typ. 39 nH typ. 39 nH typ. 39 nH

Table 4 Uprating values at reduced ambient temperature; note 1

SYMBOL	CONDITIONS	VALUES							UNIT
		10	16	25	40	63	100	200	
U_R	$T_{amb} > 85 \text{ to } 125 \text{ }^\circ\text{C}$	10	16	25	40	63	100	200	V
U_{R2}	$T_{amb} \leq 85 \text{ }^\circ\text{C}$	16	25	40	63	100	125	250	V

Note

- For applications at ambient temperatures of $\leq 85 \text{ }^\circ\text{C}$, the rated voltage (U_R) may be raised to U_{R2} .

Aluminum electrolytic capacitors

Axial High Temperature, DIN-based

119 AHT-DIN

Capacitance (C)

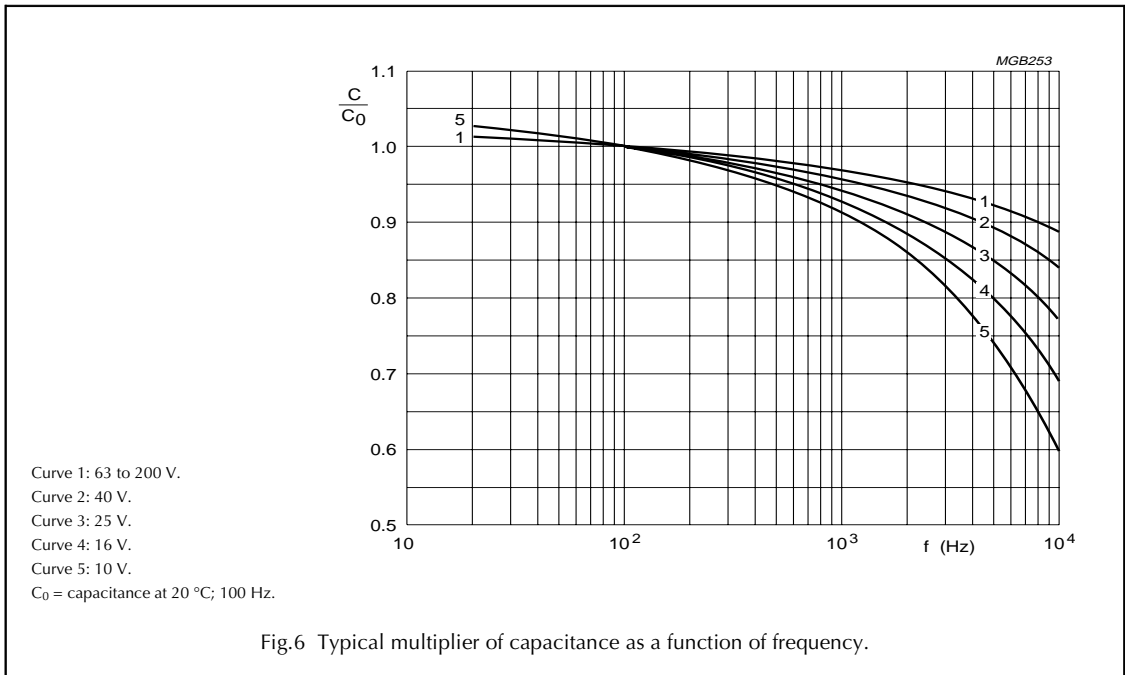
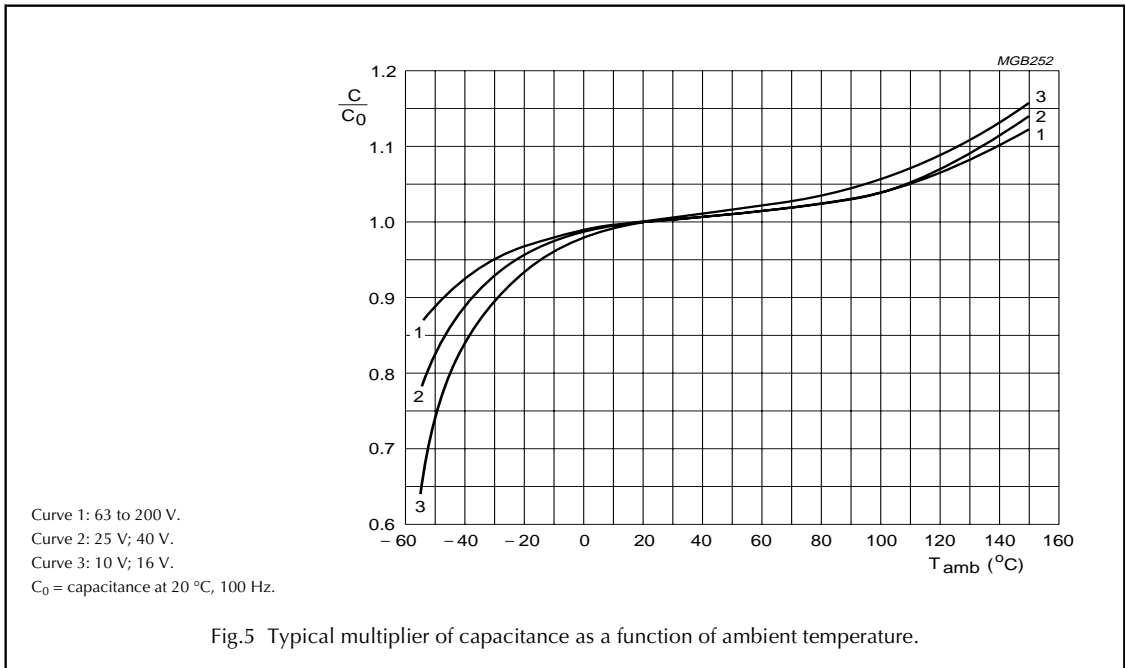

Aluminum electrolytic capacitors

Axial High Temperature, DIN-based

119 AHT-DIN

Equivalent series resistance (ESR)

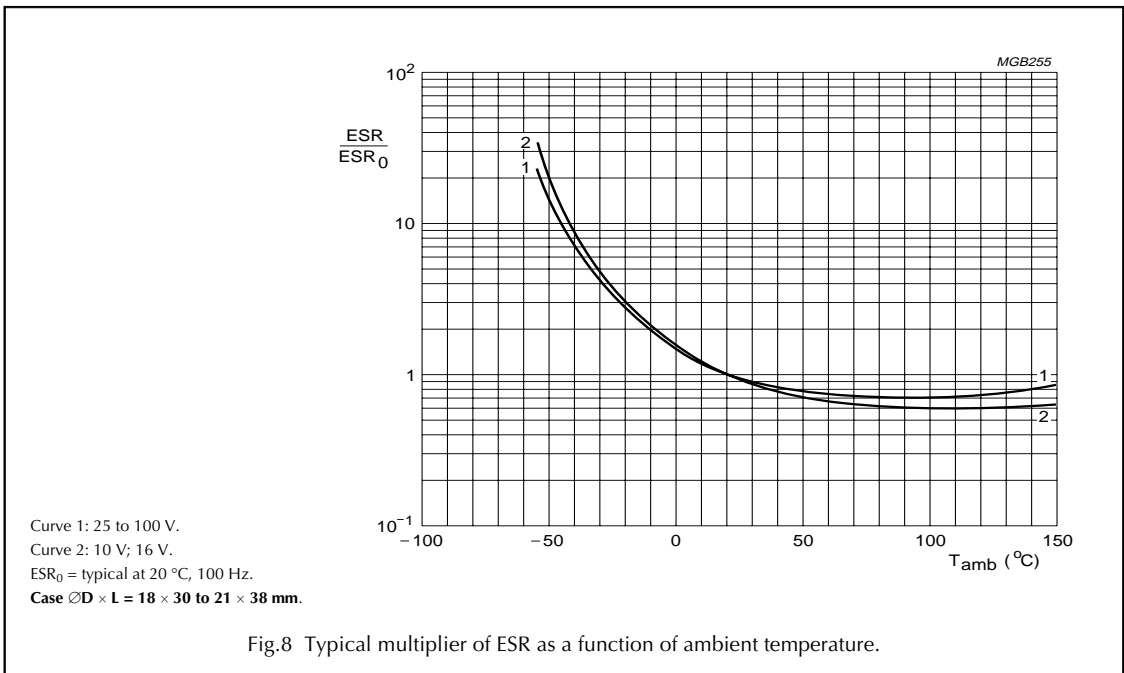
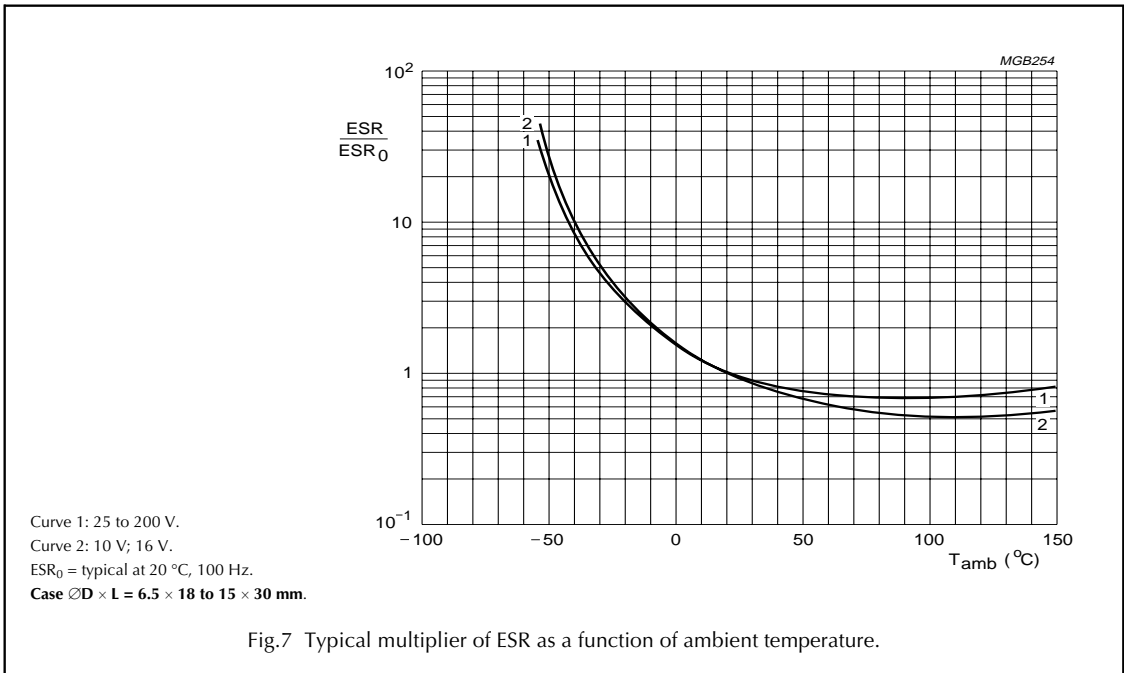

Aluminum electrolytic capacitors
Axial High Temperature, DIN-based

119 AHT-DIN

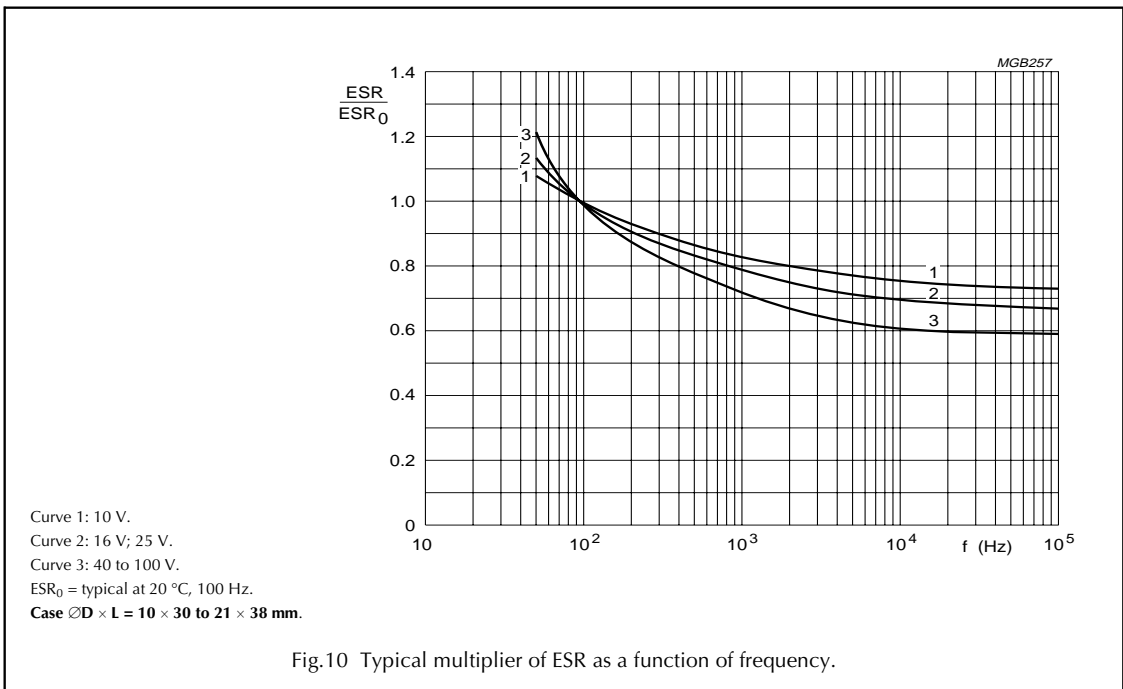
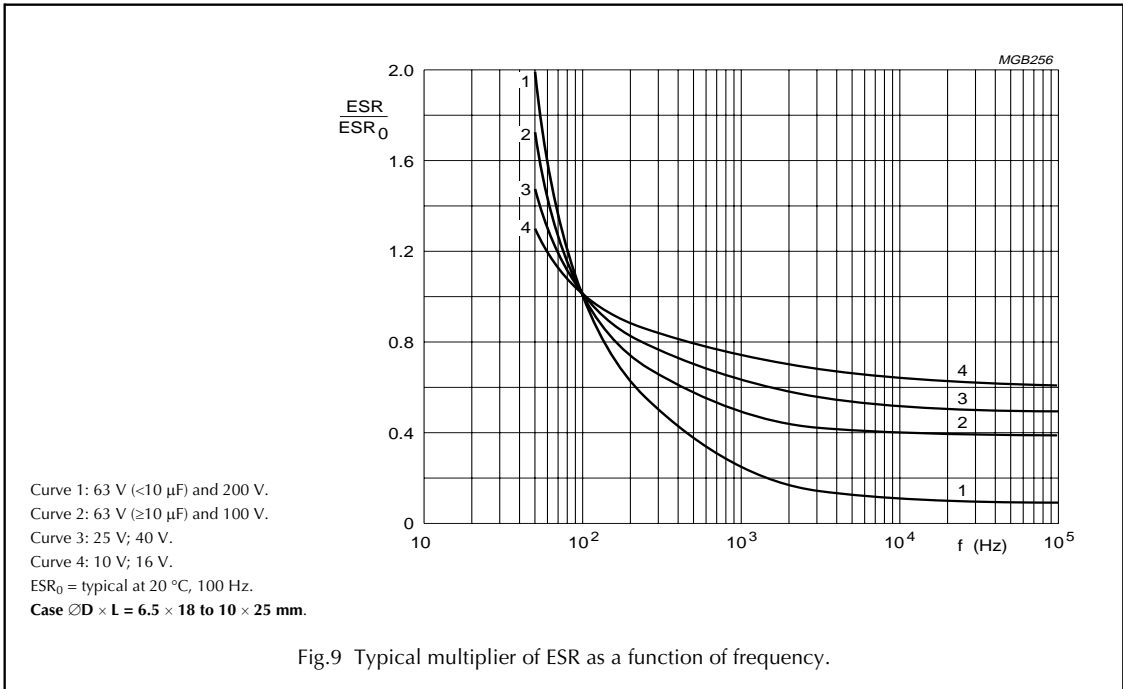

Aluminum electrolytic capacitors

Axial High Temperature, DIN-based

119 AHT-DIN

Impedance (Z)

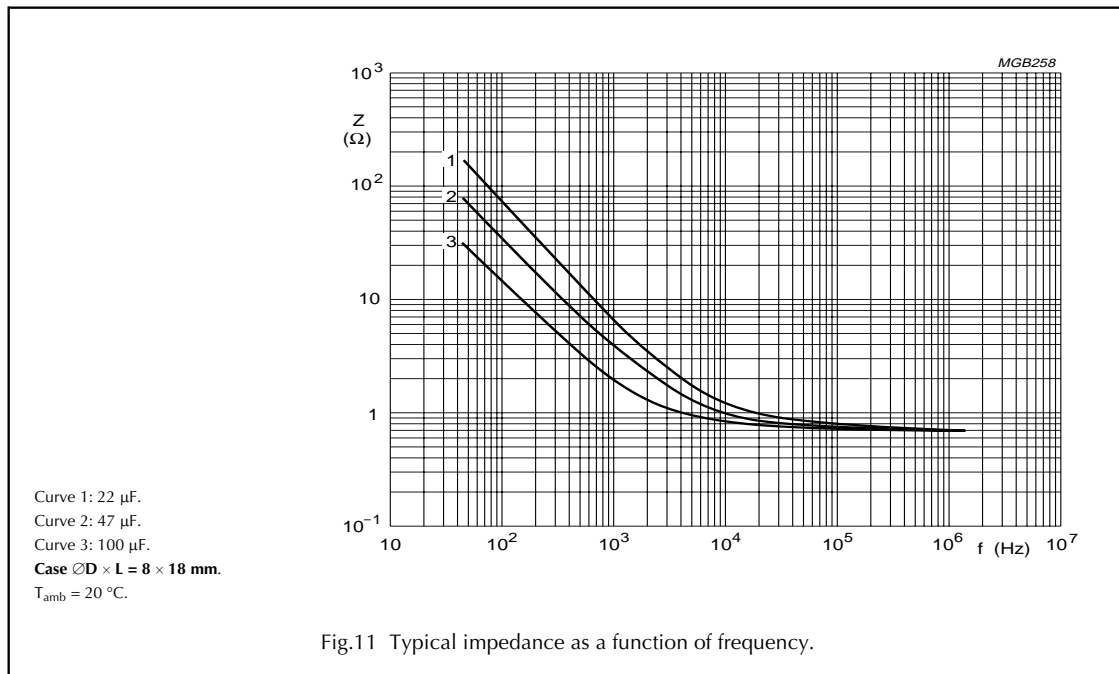

Fig.11 Typical impedance as a function of frequency.

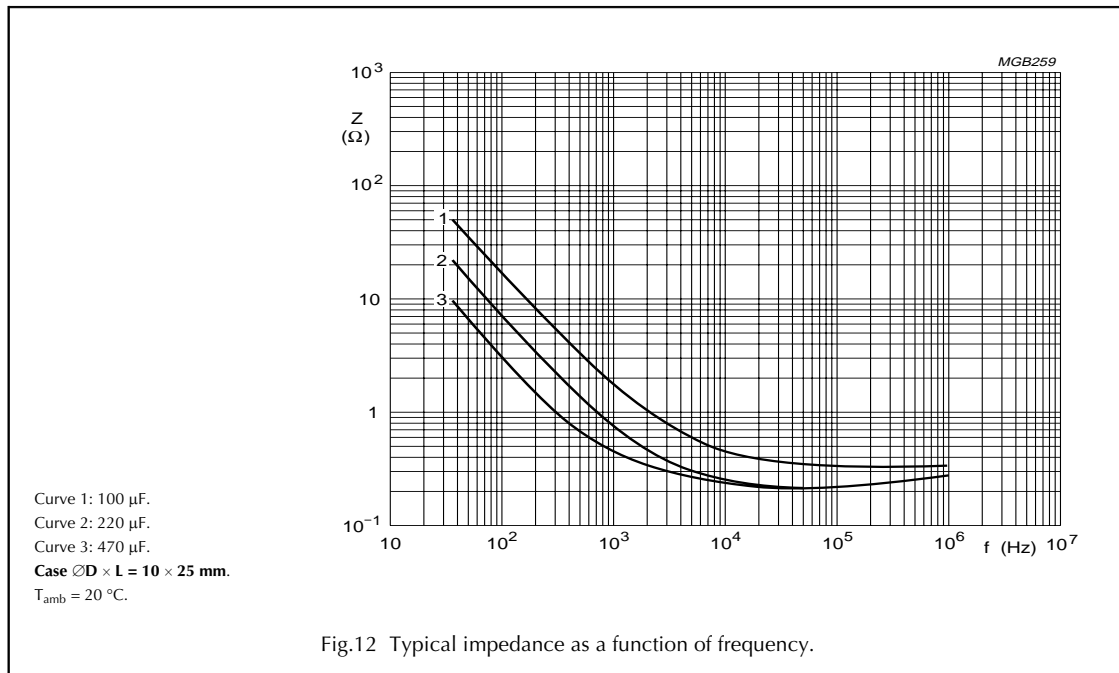

Fig.12 Typical impedance as a function of frequency.

Aluminum electrolytic capacitors
Axial High Temperature, DIN-based

119 AHT-DIN

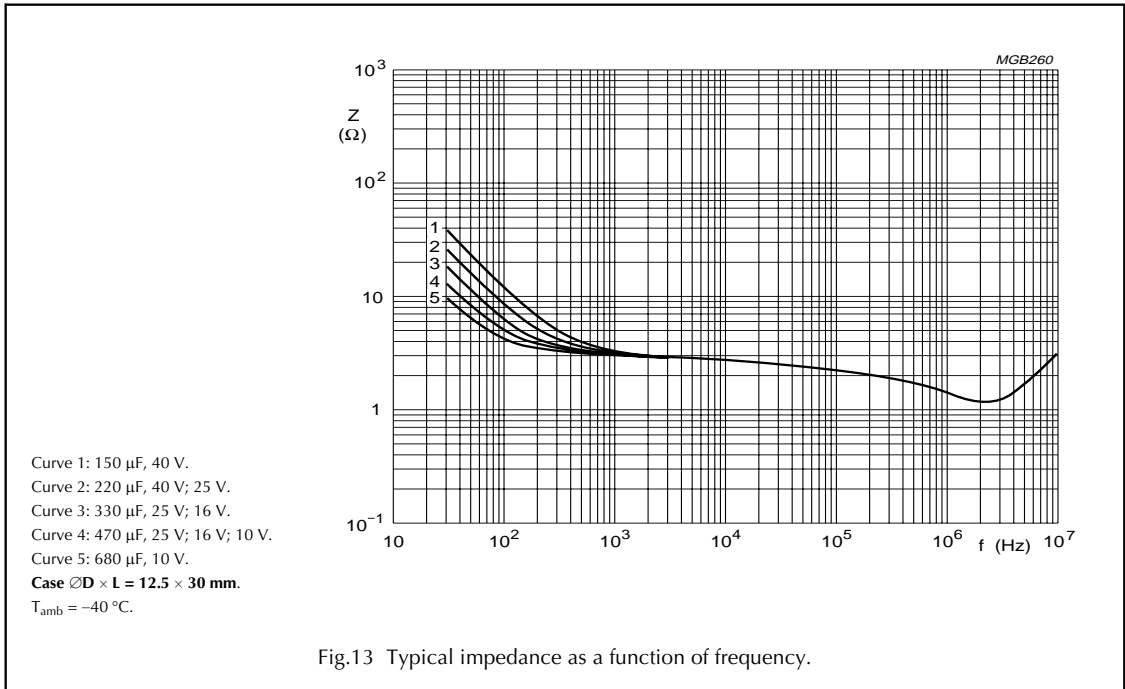

Fig.13 Typical impedance as a function of frequency.

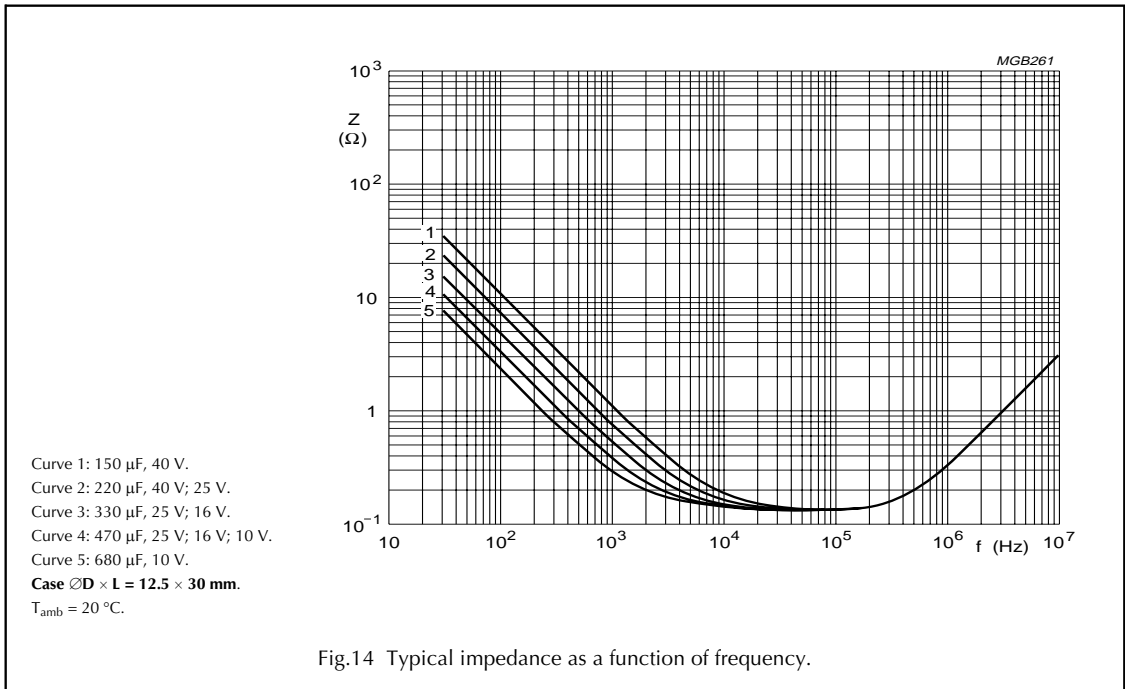
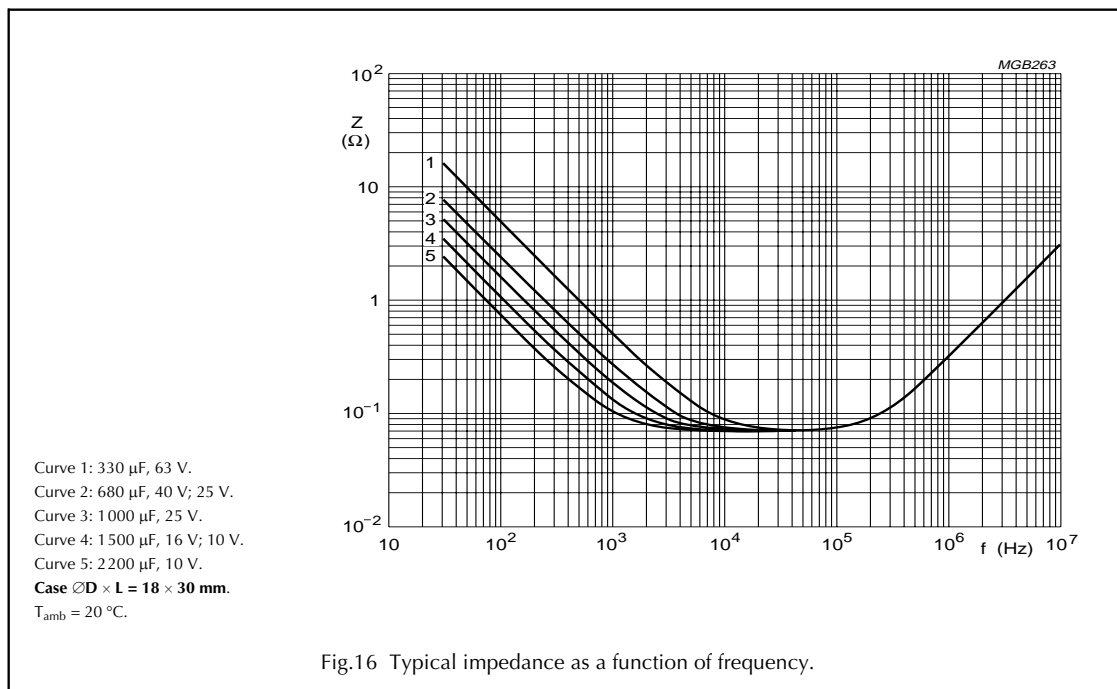
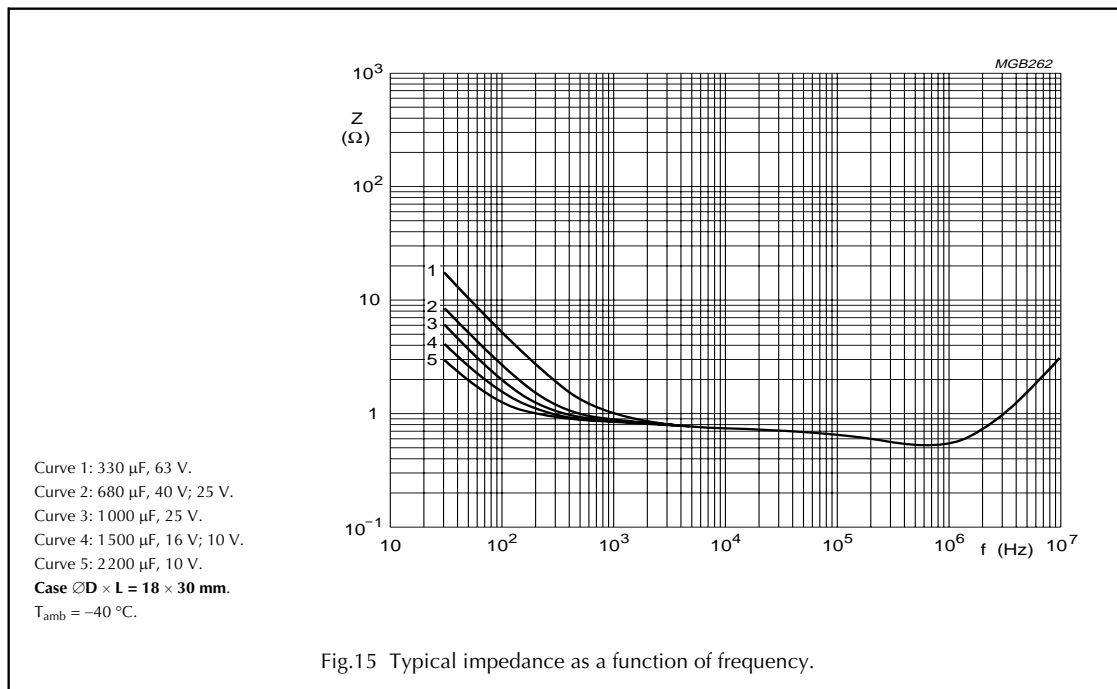

Fig.14 Typical impedance as a function of frequency.

Aluminum electrolytic capacitors

Axial High Temperature, DIN-based

119 AHT-DIN



Aluminum electrolytic capacitors

Axial High Temperature, DIN-based

119 AHT-DIN

RIPPLE CURRENT AND USEFUL LIFE

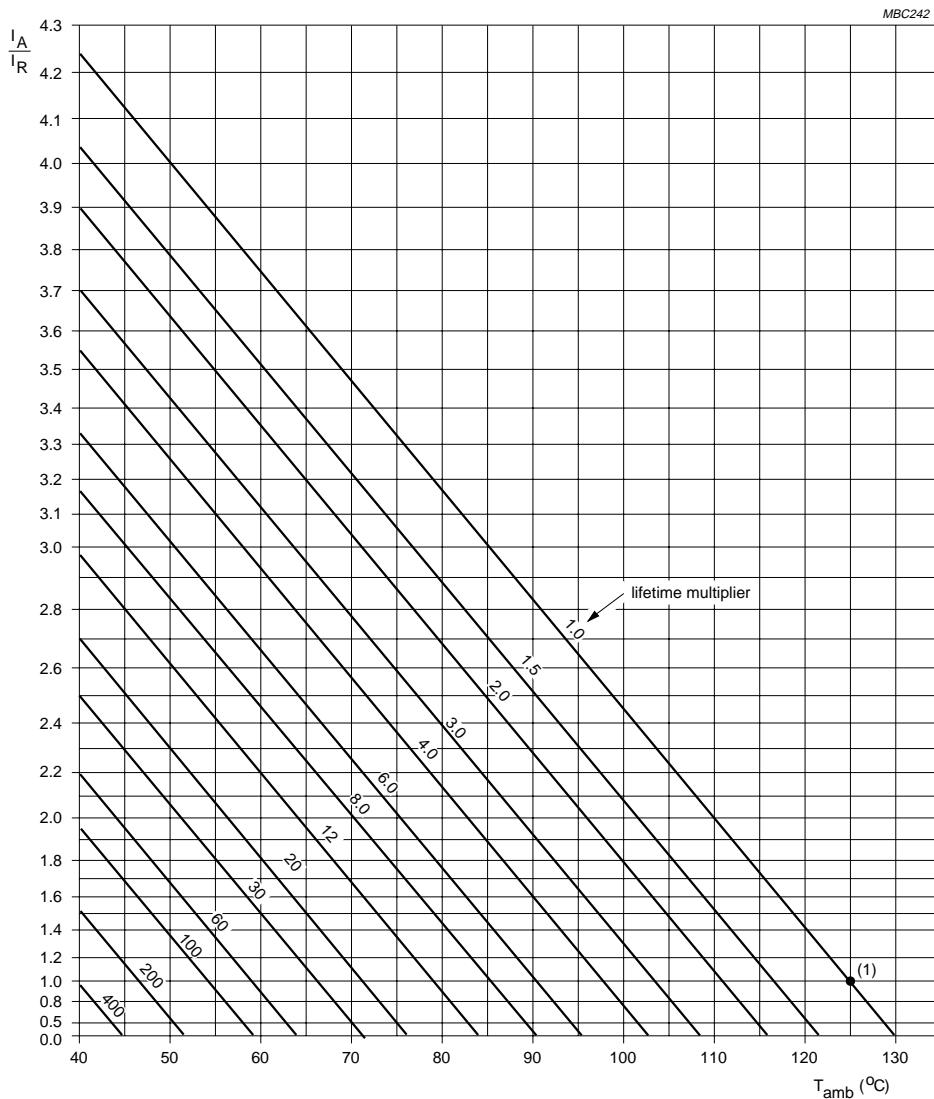

I_A = actual ripple current at 100 Hz.

I_R = rated ripple current at 100 Hz, 125 °C.

(1) Useful life at 125 °C and I_R applied:

case $\varnothing D \times L = 6.5 \times 18$ to 10×25 mm: 4000 hours

case $\varnothing D \times L = 10 \times 30$ to 21×38 mm: 8000 hours.

Fig.17 Multiplier of useful life as a function of ambient temperature and ripple current load.

Aluminum electrolytic capacitors

Axial High Temperature, DIN-based

119 AHT-DIN

Table 5 Multiplier of ripple current (I_R) as a function of frequency

FREQUENCY (Hz)	I_R MULTIPLIER		
	$U_R = 10$ and 16 V	$U_R = 25$ and 40 V	$U_R = 63$ to 200 V
50	0.95	0.9	0.85
100	1.0	1.0	1.0
300	1.07	1.12	1.2
1000	1.12	1.2	1.3
3000	1.15	1.25	1.35
≥ 10000	1.2	1.3	1.4

SPECIFIC TESTS AND REQUIREMENTS

General tests and requirements are specified in data handbook BC01, section "Tests and Requirements".

Table 6 Test procedures and requirements

TEST		PROCEDURE (quick reference)	REQUIREMENTS
NAME OF TEST	REFERENCE		
Endurance	IEC 60384-4/ EN130300 subclause 4.13	$T_{amb} = 125$ °C; U_R applied; case $\varnothing D \times L = 6.5 \times 18$ to 10×25 mm: 2000 hours; case $\varnothing D \times L = 10 \times 30$ to 21×38 mm: 4000 hours	$\Delta C/C: \pm 15\%$ $\tan \delta \leq 1.3 \times$ spec. limit $Z \leq 2 \times$ spec. limit $I_{L5} \leq$ spec. limit
Useful life	CECC 30301 subclause 1.8.1	$T_{amb} = 125$ °C; U_R and I_R applied; case $\varnothing D \times L = 6.5 \times 18$ to 10×25 mm: 4000 hours; case $\varnothing D \times L = 10 \times 30$ to 21×38 mm: 8000 hours	$\Delta C/C: \pm 45\%$ $\tan \delta \leq 3 \times$ spec. limit $Z \leq 3 \times$ spec. limit $I_{L5} \leq$ spec. limit no short or open circuit total failure percentage: $\leq 1\%$ (200 V $\leq 3\%$)
Shelf life (storage at high temperature)	IEC 60384-4/ EN130300 subclause 4.17	$T_{amb} = 125$ °C; no voltage applied; $U_R = 10$ to 63 V: 500 hours; $U_R = 100$ and 200 V: 100 hours after test: U_R to be applied for 30 minutes, 24 to 48 hours before measurement	$\Delta C/C, \tan \delta, Z$: for requirements see 'Endurance test' above $I_{L5} \leq 2 \times$ spec. limit
Reverse voltage	IEC 60384-4/ EN130300 subclause 4.15	$T_{amb} = 125$ °C: 125 hours at $U = -1$ V followed by 125 hours at U_R	$\Delta C/C: \pm 20\%$ $\tan \delta \leq$ spec. limit $I_{L5} \leq$ spec. limit