

# DATA SHEET

132/133 ALL-DIN  
**Aluminum electrolytic capacitors**  
**Axial Long Life, DIN-based**

Product specification  
Supersedes data of 18th January 2000  
File under BCcomponents, BC01

2001 Dec 12

# Aluminum electrolytic capacitors

## Axial Long Life, DIN-based

132/133 ALL-DIN

### FEATURES

- Polarized aluminum electrolytic capacitors, non-solid electrolyte
- Axial leads, cylindrical aluminum case, insulated with a blue sleeve
- Mounting ring version not insulated
- Taped versions up to  $\varnothing 15 \times 30$  mm available for automatic insertion
- Charge and discharge proof
- Long useful life:  
10000 to 15000 hours at 85 °C, high reliability
- High ripple current capability.

### APPLICATIONS

- General industrial, power supplies, telecommunication, EDP
- Coupling, decoupling, timing; smoothing, filtering and buffering in SMPS
- For use where low mounting height is important
- Vibration and shock resistant.

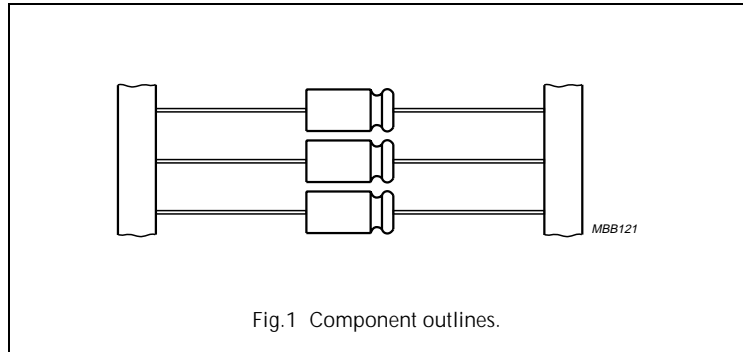
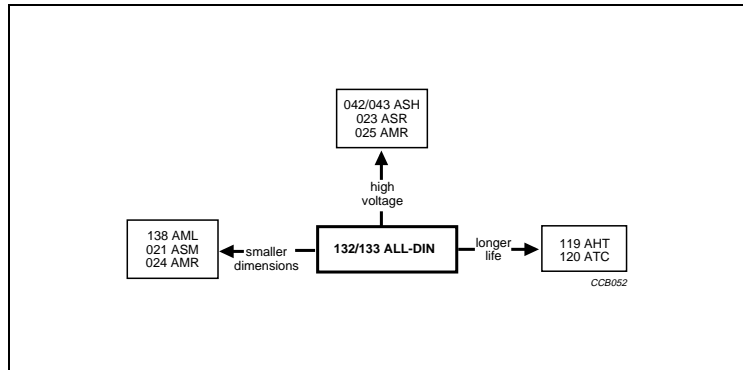

Fig.1 Component outlines.



### QUICK REFERENCE DATA

DESCRIPTION	VALUE		
	6.5 × 18 and 8 × 18	10 × 18 and 10 × 25	10 × 30 to 21 × 40
Case sizes ( $\varnothing D_{nom} \times L_{nom}$ in mm)	6.5 × 18 and 8 × 18	10 × 18 and 10 × 25	10 × 30 to 21 × 40
Rated capacitance range, $C_R$	1 to 4700 $\mu F$		
Tolerance on $C_R$	-10 to +50%		
Rated voltage range, $U_R$	10 to 350 V		
Category temperature range	-40 to +85 °C		
Endurance test at 105 °C	2000 hours	2000 hours	-
Endurance test at 85 °C	6000 hours	8000 hours	8000 hours
Useful life at 105 °C	3000 hours	3000 hours	-
Useful life at 85 °C	10000 hours	15000 hours	15000 hours
Useful life at 40 °C, $1.8 \times I_R$ applied	160000 hours	240000 hours	240000 hours
Shelf life at 0 V, 85 °C	500 hours		
Based on sectional specification	IEC 60384-4/EN130300		
Climatic category IEC 60068	40/085/56		

# Aluminum electrolytic capacitors

## Axial Long Life, DIN-based

### 132/133 ALL-DIN

Selection chart for  $C_R$ ,  $U_R$  and relevant nominal case sizes ( $\varnothing D_{nom} \times L_{nom}$  in mm)

Preferred types in **bold**.

$C_R$ ( $\mu F$ )	$U_R$ (V)								
	10	16	25	40	63	100	160	250	350
1.0	–	–	–	–	–	6.5 × 18	–	–	6.5 × 18
2.2	–	–	–	–	–	6.5 × 18	<b>6.5 × 18</b>	8 × 18	8 × 18
4.7	–	–	–	–	6.5 × 18	<b>6.5 × 18</b>	8 × 18	10 × 18	<b>8 × 18</b>
10	–	–	–	–	<b>6.5 × 18</b>	<b>8 × 18</b>	10 × 18	10 × 25	12.5 × 30 <sup>(1)</sup>
	–	–	–	–	–	–	–	10 × 30 <sup>(1)</sup>	–
22	–	–	6.5 × 18	–	<b>8 × 18</b>	<b>10 × 18</b>	10 × 25	12.5 × 30 <sup>(1)</sup>	15 × 30 <sup>(1)</sup>
	–	–	–	–	–	–	10 × 30 <sup>(1)</sup>	–	–
47	–	6.5 × 18	–	<b>8 × 18</b>	<b>10 × 18</b>	<b>10 × 25</b>	15 × 30 <sup>(1)</sup>	18 × 30 <sup>(1)</sup>	18 × 40 <sup>(1)</sup>
	–	–	–	–	–	<b>10 × 30</b>	–	–	–
68	–	–	–	–	10 × 30	12.5 × 30	15 × 30 <sup>(1)</sup>	18 × 40 <sup>(1)</sup>	21 × 40 <sup>(1)</sup>
100	–	<b>8 × 18</b>	–	<b>10 × 18</b>	<b>10 × 30</b>	<b>15 × 30</b>	18 × 30 <sup>(1)</sup>	21 × 40 <sup>(1)</sup>	–
150	–	–	–	12.5 × 30	15 × 30	18 × 30	18 × 40 <sup>(1)</sup>	–	–
220	8 × 18	<b>10 × 18</b>	<b>10 × 25</b>	<b>12.5 × 30</b>	<b>15 × 30</b>	<b>18 × 40</b>	21 × 40 <sup>(1)</sup>	–	–
	–	–	<b>12.5 × 30</b>	–	–	–	–	–	–
330	–	10 × 25	12.5 × 30	15 × 30	18 × 30	18 × 40	–	–	–
	–	12.5 × 30	–	–	–	–	–	–	–
470	<b>12.5 × 30</b>	10 × 25	<b>12.5 × 30</b>	<b>15 × 30</b>	<b>18 × 40</b>	<b>21 × 40</b>	–	–	–
	–	<b>12.5 × 30</b>	–	–	–	–	–	–	–
680	12.5 × 30	15 × 30	18 × 30	18 × 30	21 × 40	–	–	–	–
1000	<b>15 × 30</b>	<b>15 × 30</b>	<b>18 × 30</b>	<b>18 × 40</b>	<b>21 × 40</b>	–	–	–	–
1500	18 × 30	18 × 30	18 × 40	21 × 40	–	–	–	–	–
2200	<b>18 × 30</b>	<b>18 × 40</b>	<b>21 × 40</b>	<b>21 × 40</b>	–	–	–	–	–
3300	18 × 40	21 × 40	–	–	–	–	–	–	–
4700	<b>21 × 40</b>	<b>21 × 40</b>	–	–	–	–	–	–	–

#### Note

- For these CV-values see data sheet "041-043 ASH".

# Aluminum electrolytic capacitors

## Axial Long Life, DIN-based

132/133 ALL-DIN

### MECHANICAL DATA, AVAILABLE FORMS AND PACKAGING QUANTITIES

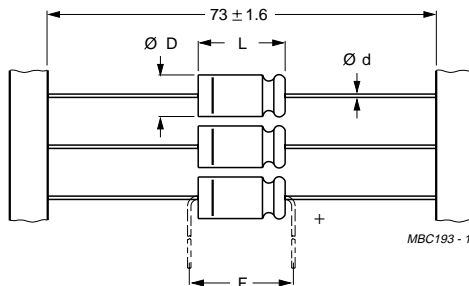

Dimensions in mm.

**Form BR:** Taped on reel,  
case  $\varnothing D \times L = 6.5 \times 18$  to  $15 \times 30$  mm.

**Form BA:** Taped in box (ammopack),  
case  $\varnothing D \times L = 6.5 \times 18$  to  $10 \times 25$  mm.

For dimensions see Table 1.

Tape dimensions are specified in data handbook BC01, section "Packaging".

Fig.2 Dimensional outline; Forms BA and BR.

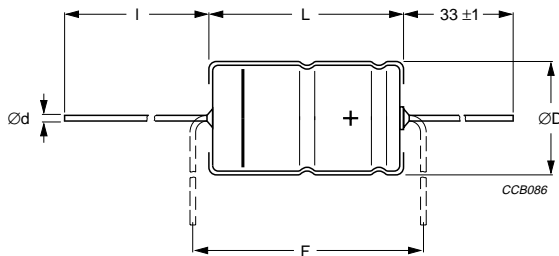

Dimensions in mm.

**Form AA:** Axial in box,  
case  $\varnothing D \times L = 10 \times 30$  to  $21 \times 40$  mm

For dimensions see Table 1.

Fig.3 Dimensional outline; Form AA.

# Aluminum electrolytic capacitors

## Axial Long Life, DIN-based

132/133 ALL-DIN

**Table 1 Axial;** physical dimensions, mass and packaging quantities; see Figs 2 and 3

NOMINAL CASE SIZE ØD × L (mm)	CASE CODE	AXIAL: FORM AA, BA, and BR					MASS (g)	PACKAGING QUANTITIES		
		Ød (mm)	l (mm)	ØD <sub>max</sub> (mm)	L <sub>max</sub> (mm)	F <sub>min</sub> (mm)		FORM AA	FORM BA	FORM BR
6.5 × 18	4	0.8	–	6.9	18.5	25	≈1.3	–	1000	1000
8 × 18	5	0.8	–	8.5	18.5	25	≈1.7	–	500	500
10 × 18	6	0.8	–	10.5	18.5	25	≈2.5	–	500	500
10 × 25	7	0.8	–	10.5	25.0	30	≈3.3	–	500	500
10 × 30	00	0.8	55 ±1	10.5	30.5	35	≈4.8	200	–	500
12.5 × 30	01	0.8	55 ±1	13.0	30.5	35	≈7.4	200	–	400
15 × 30	02	0.8	55 ±1	15.5	30.5	35	≈11.7	200	–	250
18 × 30	03	0.8	55 ±1	18.5	30.5	35	≈12.9	200	–	–
18 × 40	04	0.8	34 ±1	18.5	42.2	45	≈19.4	100	–	–
21 × 40	05	0.8	34 ±1	21.5	42.2	45	≈24.7	100	–	–

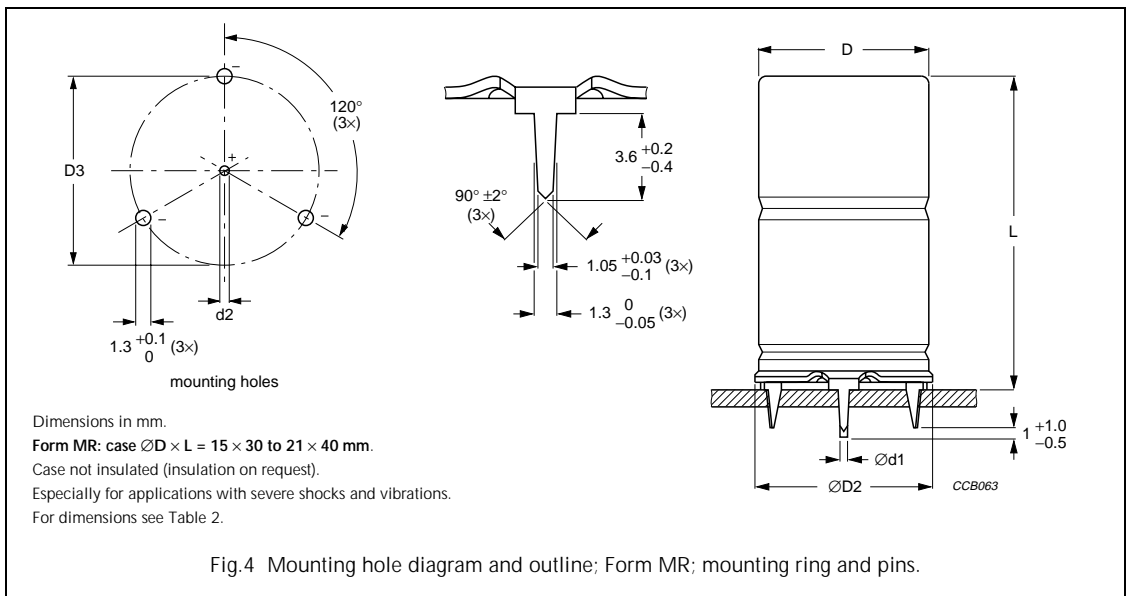

Fig. 4 Mounting hole diagram and outline; Form MR; mounting ring and pins.

**Table 2 Mounting ring;** physical dimensions, mass and packaging quantities; see Fig. 4

NOMINAL CASE SIZE ØD × L (mm)	CASE CODE	MOUNTING RING: FORM MR						MASS (g)	PACKAGING QUANTITIES
		Ød1 (mm)	Ød2 (mm)	ØD <sub>max</sub> (mm)	ØD2 <sub>max</sub> (mm)	D3 (mm)	L <sub>max</sub> (mm)		
15 × 30	02	0.8	1.0 +0.4	15.5	17.5	16.5 ±0.2	33	≈11.7	200
18 × 30	03	0.8	1.0 +0.4	18.5	19.5	18.5 ±0.2	33	≈12.9	200
18 × 40	04	0.8	1.0 +0.4	18.5	19.5	18.5 ±0.2	45	≈19.4	100
21 × 40	05	0.8	1.0 +0.4	21.5	22.5	21.5 ±0.2	45	≈24.7	100

# Aluminum electrolytic capacitors

## Axial Long Life, DIN-based

### 132/133 ALL-DIN

#### Ordering example

Electrolytic capacitor 132 series

100  $\mu$ F/40 V;  $-10/+50\%$

Nominal case size:  $\varnothing 10 \times 18$  mm; Form BR

Catalogue number: 2222 132 27101.

#### ELECTRICAL DATA AND ORDERING INFORMATION

Unless otherwise specified, all electrical values in Tables 3 apply at  $T_{amb} = 20$  °C,  $P = 86$  to 106 kPa,  $RH = 45$  to 75%.

SYMBOL	DESCRIPTION
$C_R$	rated capacitance at 100 Hz (tolerance $-10$ to $+50\%$ )
$I_R$	rated RMS ripple current at 100 Hz, 85 °C
$I_{L5}$	max. leakage current after 5 minutes at $U_R$
Tan $\delta$	max. dissipation factor at 100 Hz
ESR	equivalent series resistance at 100 Hz (calculated from tan $\delta_{max}$ and $C_R$ )
Z	max. impedance at 10 kHz or 100 kHz

Table 3 Electrical data: preferred types in bold

$U_R$ (V)	$C_R$ 100 Hz ( $\mu$ F)	NOMINAL CASE SIZE $\varnothing D \times L$ (mm)	$I_R$ 100 Hz 85 °C (mA)	$I_{L5}$ 5 min ( $\mu$ A)	Tan $\delta$ 100 Hz	ESR 100 Hz ( $\Omega$ )	Z 10 kHz ( $\Omega$ )	Z 100 kHz ( $\Omega$ )	CATALOGUE NUMBER 2222 . . . . .			
									IN BOX FORM AA	TAPED ON REEL FORM BR	TAPED IN BOX FORM BA	MOUNTING RING FORM MR
10	220	8 $\times$ 18	190	8.4	0.18	1.3	0.73	0.70	–	132 24221	132 34221	–
	<b>470</b>	<b>12.5 <math>\times</math> 30</b>	350	9.4	0.18	0.61	0.26	0.60	<b>132 14471</b>	<b>132 24471</b>	–	–
	680	12.5 $\times$ 30	460	13.6	0.18	0.42	0.20	0.40	132 14681	132 24681	–	–
	<b>1000</b>	<b>15 <math>\times</math> 30</b>	640	20	0.18	0.28	0.12	–	<b>132 14102</b>	<b>132 24102</b>	–	<b>132 44102</b>
	1500	18 $\times$ 30	800	30	0.22	0.23	0.10	–	132 14152	–	–	132 44152
	<b>2200</b>	<b>18 <math>\times</math> 30</b>	1100	44	0.22	0.16	0.09	–	<b>132 14222</b>	–	–	<b>132 44222</b>
	3300	18 $\times$ 40	1300	66	0.27	0.13	0.05	–	132 14332	–	–	132 44332
	<b>4700</b>	<b>21 <math>\times</math> 40</b>	1800	94	0.27	0.09	0.05	–	<b>132 14472</b>	–	–	<b>132 44472</b>
16	47	6.5 $\times$ 18	95	5.5	0.14	4.7	2.6	2.2	–	132 25479	132 35479	–
	<b>100</b>	<b>8 <math>\times</math> 18</b>	150	7.2	0.14	2.2	1.2	1.1	–	132 25101	<b>132 35101</b>	–
	<b>220</b>	<b>10 <math>\times</math> 18</b>	250	11	0.14	1.0	0.55	0.55	–	132 25221	<b>132 35221</b>	–
	330	10 $\times$ 25	320	14.6	0.14	0.67	0.36	0.36	–	132 90508	132 90509	–
	330	12.5 $\times$ 30	320	10.6	0.14	0.67	0.36	0.60	132 15331	132 25331	–	–
	470	10 $\times$ 25	450	19	0.14	0.47	0.26	0.26	–	132 90507	132 90502	–
	<b>470</b>	<b>12.5 <math>\times</math> 30</b>	450	15	0.14	0.47	0.26	0.40	<b>132 15471</b>	<b>132 25471</b>	–	–
	680	15 $\times$ 30	550	22	0.14	0.33	0.14	–	132 15681	132 25681	–	132 45681
	<b>1000</b>	<b>15 <math>\times</math> 30</b>	780	32	0.14	0.22	0.12	–	<b>132 15102</b>	<b>132 25102</b>	–	<b>132 45102</b>

# Aluminum electrolytic capacitors

## Axial Long Life, DIN-based

### 132/133 ALL-DIN

U <sub>R</sub> (V)	C <sub>R</sub> 100 Hz (μF)	NOMINAL CASE SIZE ∅D × L (mm)	I <sub>R</sub> 100 Hz 85 °C (mA)	I <sub>L5</sub> 5 min (μA)	Tan δ 100 Hz	ESR 100 Hz (Ω)	Z 10 kHz (Ω)	Z 100 kHz (Ω)	CATALOGUE NUMBER 2222 . . . . .			
									IN BOX FORM AA	TAPED ON REEL FORM BR	TAPED IN BOX FORM BA	MOUNTING RING FORM MR
16	1500	18 × 30	950	48	0.15	0.16	0.10	–	132 15152	–	–	132 45152
	<b>2200</b>	<b>18 × 40</b>	1300	70	0.15	0.11	0.06	–	<b>132 15222</b>	–	–	<b>132 45222</b>
	3300	21 × 40	1600	110	0.15	0.07	0.05	–	132 15332	–	–	132 45332
	<b>4700</b>	<b>21 × 40</b>	2300	150	0.15	0.05	0.05	–	<b>132 15472</b>	–	–	<b>132 45472</b>
25	22	6.5 × 18	60	5.1	0.11	8.0	4.1	2.9	–	132 26229	132 36229	–
	<b>220</b>	<b>10 × 25</b>	340	15	0.11	0.8	0.40	0.40	–	132 90503	<b>132 90504</b>	–
	<b>220</b>	<b>12.5 × 30</b>	340	11	0.11	0.8	0.40	0.60	<b>132 16221</b>	<b>132 26221</b>	–	–
	330	12.5 × 30	410	16.5	0.11	0.53	0.30	0.40	132 16331	132 26331	–	–
	<b>470</b>	<b>12.5 × 30</b>	560	24	0.11	0.37	0.20	–	<b>132 16471</b>	<b>132 26471</b>	–	–
	680	18 × 30	700	34	0.11	0.26	0.10	–	132 16681	–	–	132 46681
	<b>1000</b>	<b>18 × 30</b>	1000	50	0.11	0.17	0.10	–	<b>132 16102</b>	–	–	<b>132 46102</b>
	1500	18 × 40	1100	75	0.12	0.13	0.06	–	132 16152	–	–	132 46152
	<b>2200</b>	<b>21 × 40</b>	1850	110	0.13	0.09	0.05	–	<b>132 16222</b>	–	–	<b>132 46222</b>
40	<b>47</b>	<b>8 × 18</b>	120	7.8	0.09	3.0	1.6	1.4	–	132 27479	<b>132 37479</b>	–
	<b>100</b>	<b>10 × 18</b>	210	12	0.09	1.4	0.75	0.75	–	132 27101	<b>132 37101</b>	–
	150	10 × 25	310	16	0.09	0.95	0.50	0.50	–	132 90511	132 90512	–
	150	12.5 × 30	310	12	0.09	0.95	0.50	0.60	132 17151	132 27151	–	–
	<b>220</b>	<b>12.5 × 30</b>	410	17.5	0.09	0.65	0.34	0.40	<b>132 17221</b>	<b>132 27221</b>	–	–
	330	15 × 30	550	26	0.09	0.43	0.20	–	132 17331	132 27331	–	132 47331
	<b>470</b>	<b>15 × 30</b>	700	38	0.09	0.30	0.16	–	<b>132 17471</b>	<b>132 27471</b>	–	<b>132 47471</b>
	680	18 × 30	900	54	0.09	0.21	0.10	–	132 17681	–	–	132 47681
	<b>1000</b>	<b>18 × 40</b>	1200	80	0.09	0.14	0.08	–	<b>132 17102</b>	–	–	<b>132 47102</b>
	1500	21 × 40	1500	120	0.10	0.10	0.06	–	132 17152	–	–	132 47152
	<b>2200</b>	<b>21 × 40</b>	1900	180	0.10	0.07	0.05	–	<b>132 17222</b>	–	–	<b>132 47222</b>
63	4.7	6.5 × 18	38	4.6	0.07	24	12	5	–	132 28478	132 38478	–
	<b>10</b>	<b>6.5 × 18</b>	64	5.3	0.07	11	5.5	3.3	–	132 28109	<b>132 38109</b>	–
	<b>22</b>	<b>8 × 18</b>	100	6.8	0.07	5.1	2.5	2.1	–	132 28229	<b>132 38229</b>	–
	<b>47</b>	<b>10 × 18</b>	170	9.9	0.07	2.4	1.2	1.2	–	132 28479	<b>132 38479</b>	–
	68	10 × 25	210	12.6	0.07	1.6	0.81	0.60	–	132 90513	132 90514	–

# Aluminum electrolytic capacitors

## Axial Long Life, DIN-based

### 132/133 ALL-DIN

U <sub>R</sub> (V)	C <sub>R</sub> 100 Hz (μF)	NOMINAL CASE SIZE ∅D × L (mm)	I <sub>R</sub> 100 Hz 85 °C (mA)	I <sub>L5</sub> 5 min (μA)	Tan δ 100 Hz	ESR 100 Hz (Ω)	Z 10 kHz (Ω)	Z 100 kHz (Ω)	CATALOGUE NUMBER 2222 . . . . .			
									IN BOX FORM AA	TAPED ON REEL FORM BR	TAPED IN BOX FORM BA	MOUNTING RING FORM MR
63	68	10 × 30	210	8.6	0.07	1.6	0.80	0.60	132 18689	132 28689	–	–
	<b>100</b>	<b>10 × 30</b>	300	12.6	0.07	1.1	0.60	0.40	<b>132 18101</b>	<b>132 28101</b>	–	–
	150	15 × 30	350	19	0.07	0.74	0.37	–	132 18151	132 28151	–	132 48151
	<b>220</b>	<b>15 × 30</b>	520	28	0.07	0.50	0.25	–	<b>132 18221</b>	<b>132 28221</b>	–	<b>132 48221</b>
	330	18 × 30	600	42	0.07	0.34	0.15	–	132 18331	–	–	132 48331
	<b>470</b>	<b>18 × 40</b>	970	59	0.07	0.24	0.12	–	<b>132 18471</b>	–	–	<b>132 48471</b>
	680	21 × 40	1000	86	0.07	0.16	0.08	–	132 18681	–	–	132 48681
	<b>1000</b>	<b>21 × 40</b>	1600	130	0.07	0.11	0.06	–	<b>132 18102</b>	–	–	<b>132 48102</b>
100	1	6.5 × 18	20	4.0	0.06	95	45	6	–	132 29108	132 39108	–
	2.2	6.5 × 18	30	4.4	0.06	43	20	5	–	132 29228	132 39228	–
	<b>4.7</b>	<b>6.5 × 18</b>	48	4.9	0.06	20	9.6	4	–	132 29478	<b>132 39478</b>	–
	<b>10</b>	<b>8 × 18</b>	73	6	0.06	9.5	4.5	2.8	–	132 29109	<b>132 39109</b>	–
	<b>22</b>	<b>10 × 18</b>	130	8.4	0.06	4.3	2	1.3	–	132 29229	<b>132 39229</b>	–
	<b>47</b>	<b>10 × 25</b>	220	13.4	0.06	2.0	1	0.90	–	132 90505	<b>132 90506</b>	–
	<b>47</b>	<b>10 × 30</b>	220	9.4	0.06	2.0	1	0.90	<b>132 19479</b>	<b>132 29479</b>	–	–
	68	12.5 × 30	250	13.5	0.06	1.4	0.80	–	132 19689	132 29689	–	–
	<b>100</b>	<b>15 × 30</b>	380	20	0.06	0.95	0.50	–	<b>132 19101</b>	<b>132 29101</b>	–	<b>132 49101</b>
	150	18 × 30	400	30	0.06	0.64	0.35	–	132 19151	–	–	132 49151
	<b>220</b>	<b>18 × 40</b>	660	44	0.06	0.43	0.20	–	<b>132 19221</b>	–	–	<b>132 49221</b>
	330	18 × 40	700	66	0.06	0.29	0.15	–	132 19331	–	–	132 49331
	<b>470</b>	<b>21 × 40</b>	1200	94	0.06	0.20	0.10	–	<b>132 19471</b>	–	–	<b>132 49471</b>

# Aluminum electrolytic capacitors

## Axial Long Life, DIN-based

### 132/133 ALL-DIN

U <sub>R</sub> (V)	C <sub>R</sub> 100 Hz (μF)	NOMINAL CASE SIZE ∅D × L (mm)	I <sub>R</sub> 100 Hz 85 °C (mA)	I <sub>L5</sub> 5 min (μA)	Tan δ 100 Hz	ESR 100 Hz (Ω)	Z 10 kHz (Ω)	Z 100 kHz (Ω)	CATALOGUE NUMBER 2222 . . . . .			
									IN BOX FORM AA	TAPED ON REEL FORM BR	TAPED IN BOX FORM BA	MOUNTING RING FORM MR
160	2.2	6.5 × 18	22	20	0.10	72	55	30	–	133 21228	<b>133 31228</b>	–
	4.7	8 × 18	37	20	0.10	34	26	20	–	133 21478	133 31478	–
	10	10 × 18	61	20	0.10	16	12	10	–	133 21109	133 31109	–
	22	10 × 25	120	20	0.10	7.2	5.5	2.5	–	133 90502	133 90503	–
250	2.2	8 × 18	25	20	0.10	72	50	30	–	133 23228	133 33228	–
	4.7	10 × 18	37	20	0.10	34	23	16	–	133 23478	133 33478	–
	10	10 × 25	66	20	0.10	16	11	9	–	133 23109	133 33109	–
350	1	6.5 × 18	15	20	0.10	160	100	40	–	133 25108	133 35108	–
	2.2	8 × 18	25	20	0.10	72	45	28	–	133 25228	133 35228	–
	4.7	8 × 18	43	20	0.10	34	21	15	–	133 90511	<b>133 90509</b>	–

# Aluminum electrolytic capacitors

## Axial Long Life, DIN-based

132/133 ALL-DIN

## Additional electrical data

PARAMETER	CONDITIONS	VALUE	
		AXIAL	MOUNTING RING
<b>Voltage</b>			
Surge voltage	$U_R = 10$ to $250$ V	$U_S \leq 1.15 \times U_R$	
	$U_R = 350$ V	$U_S \leq 1.1 \times U_R$	
Reverse voltage		$U_{rev} \leq 1$ V	
<b>Current</b>			
Leakage current	after 1 minute: case $\varnothing D \times L = 6.5 \times 18$ to $10 \times 25$ mm: $U_R = 10$ to $100$ V $U_R = 160$ to $350$ V case $\varnothing D \times L = 10 \times 30$ to $21 \times 40$ mm: $U_R = 10$ to $100$ V	$I_{L1} \leq 0.01 C_R \times U_R + 3 \mu A$ $I_{L1} \leq 50 \mu A$	
	after 5 minutes: case $\varnothing D \times L = 6.5 \times 18$ to $10 \times 25$ mm: $U_R = 10$ to $100$ V $U_R = 160$ to $350$ V case $\varnothing D \times L = 10 \times 30$ to $21 \times 40$ mm: $U_R = 10$ to $100$ V	$I_{L5} \leq 0.002 C_R \times U_R + 4 \mu A$ $I_{L5} \leq 20 \mu A$	
<b>Inductance</b>			
Equivalent series inductance (ESL)	case $\varnothing D \times L$ mm:		
	6.5 × 18	typ. 15 nH	–
	8 × 18	typ. 35 nH	–
	10 × 18	typ. 69 nH	–
	10 × 25	typ. 38 nH	–
	10 × 30	typ. 38 nH	–
	12.5 × 30	typ. 46 nH	–
	15 × 30	typ. 48 nH	typ. 39 nH
	18 × 30	typ. 50 nH	typ. 39 nH
	18 × 40	typ. 54 nH	typ. 39 nH
	21 × 40	typ. 59 nH	typ. 39 nH

# Aluminum electrolytic capacitors

## Axial Long Life, DIN-based

132/133 ALL-DIN

### Capacitance (C)

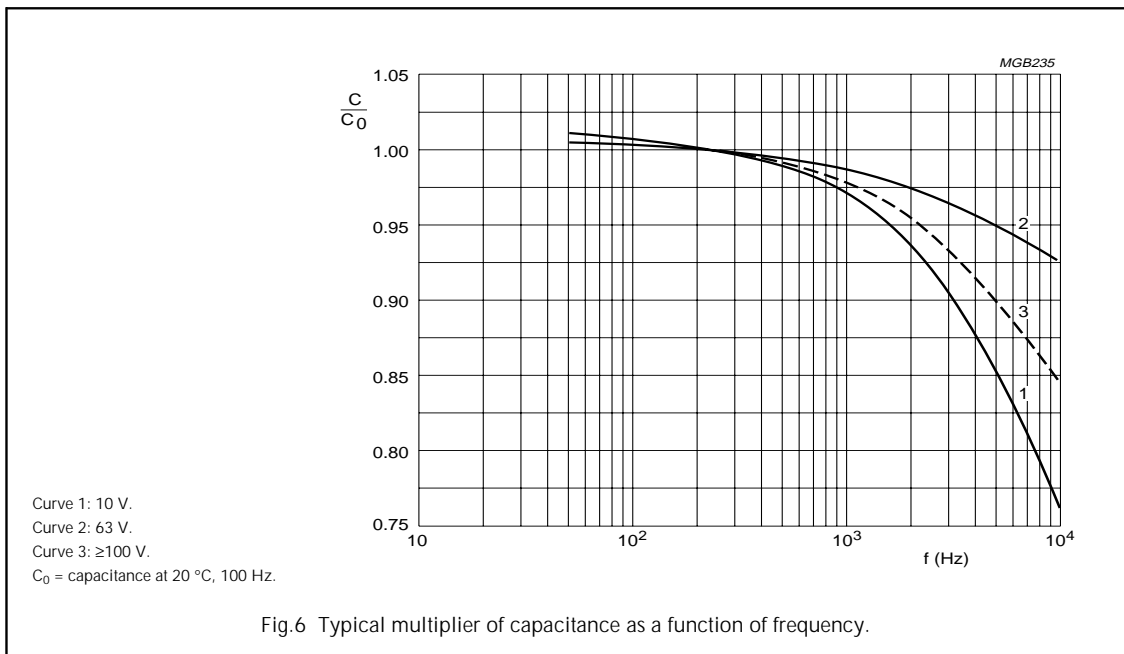
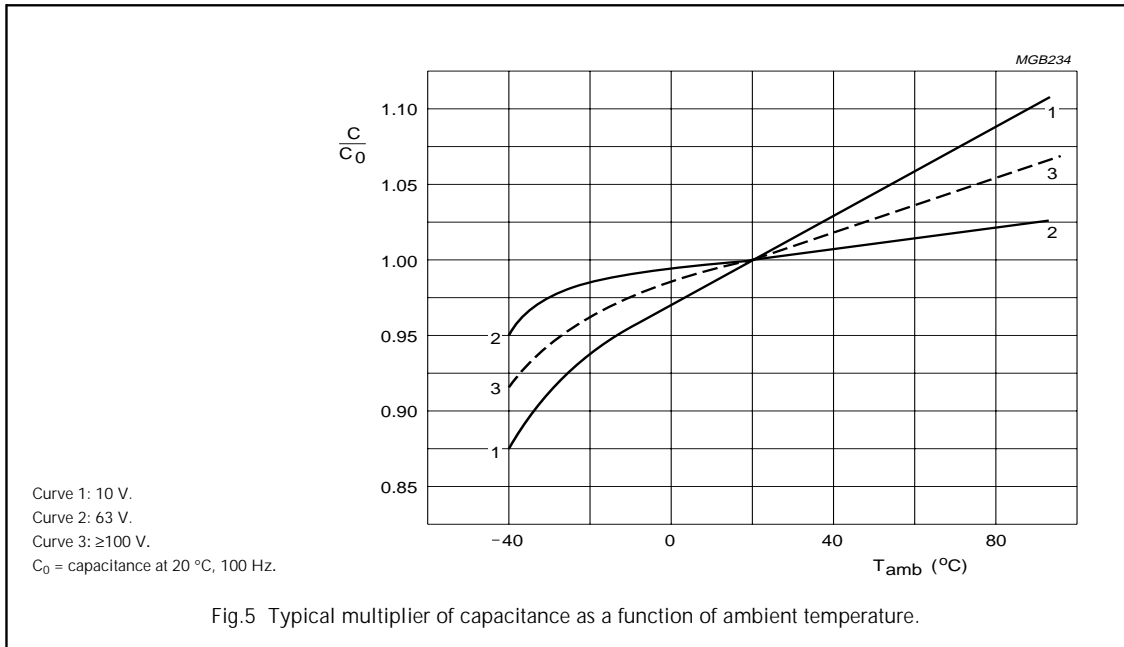

# Aluminum electrolytic capacitors

## Axial Long Life, DIN-based

132/133 ALL-DIN

Dissipation factor ( $\tan \delta$ )

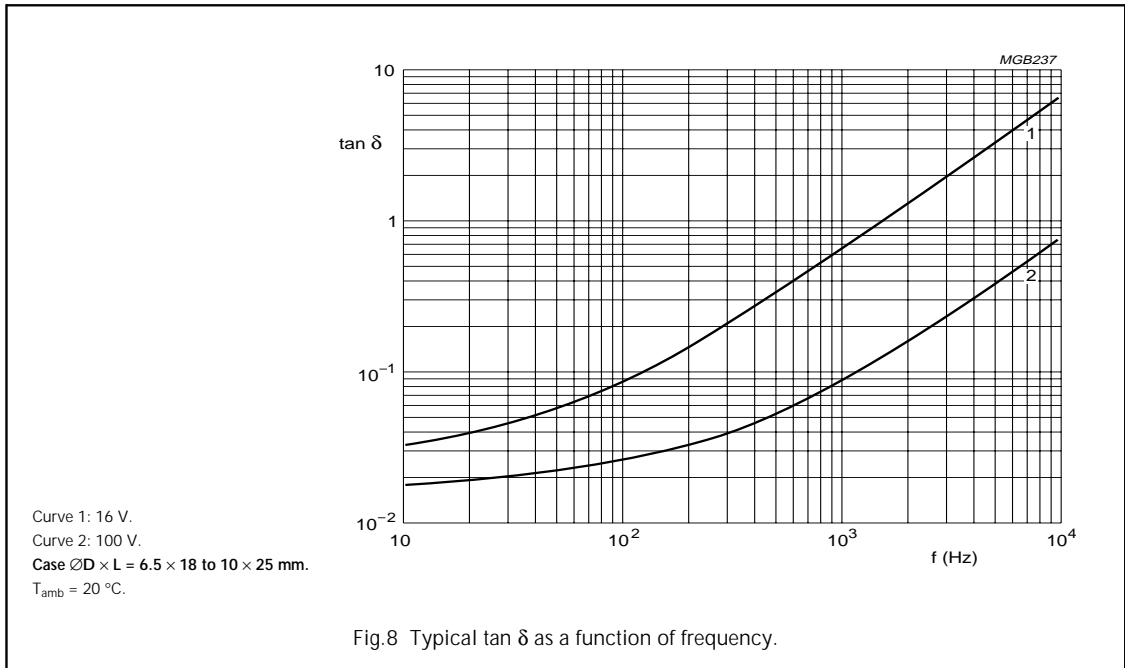
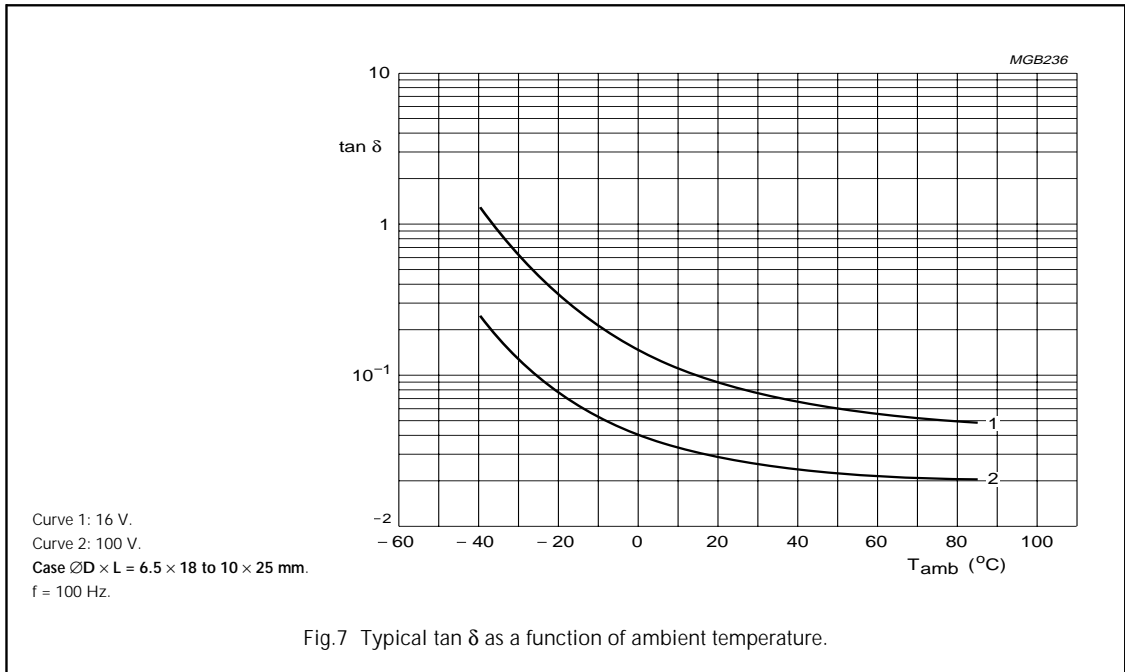

# Aluminum electrolytic capacitors

## Axial Long Life, DIN-based

132/133 ALL-DIN

### Impedance (Z)

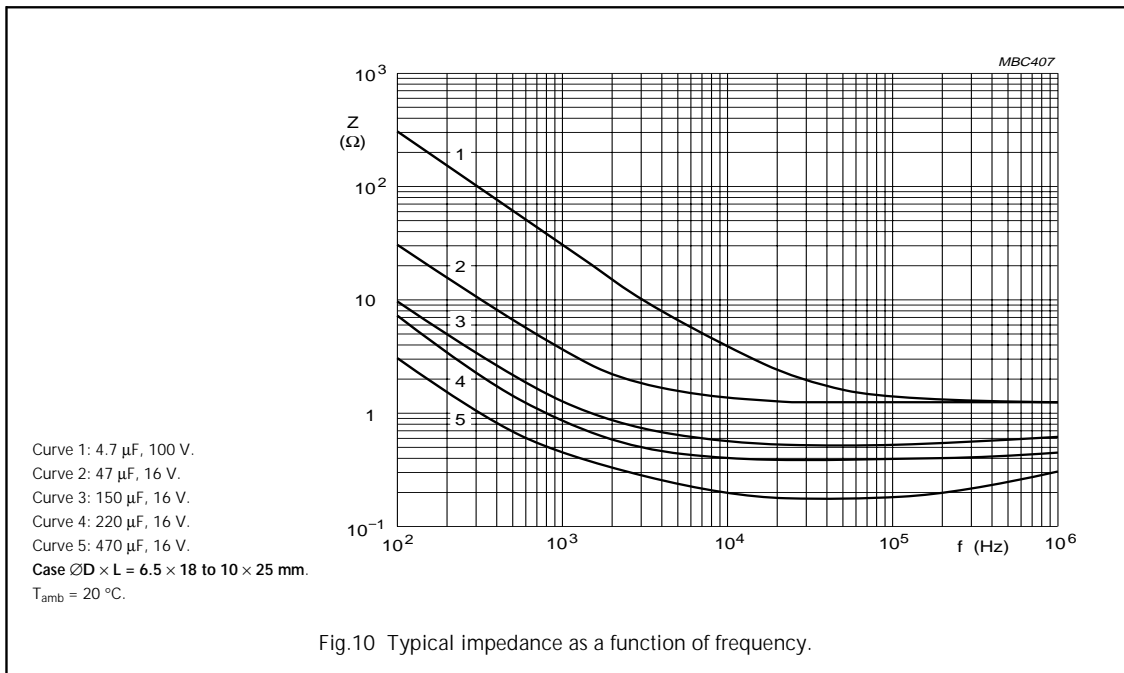
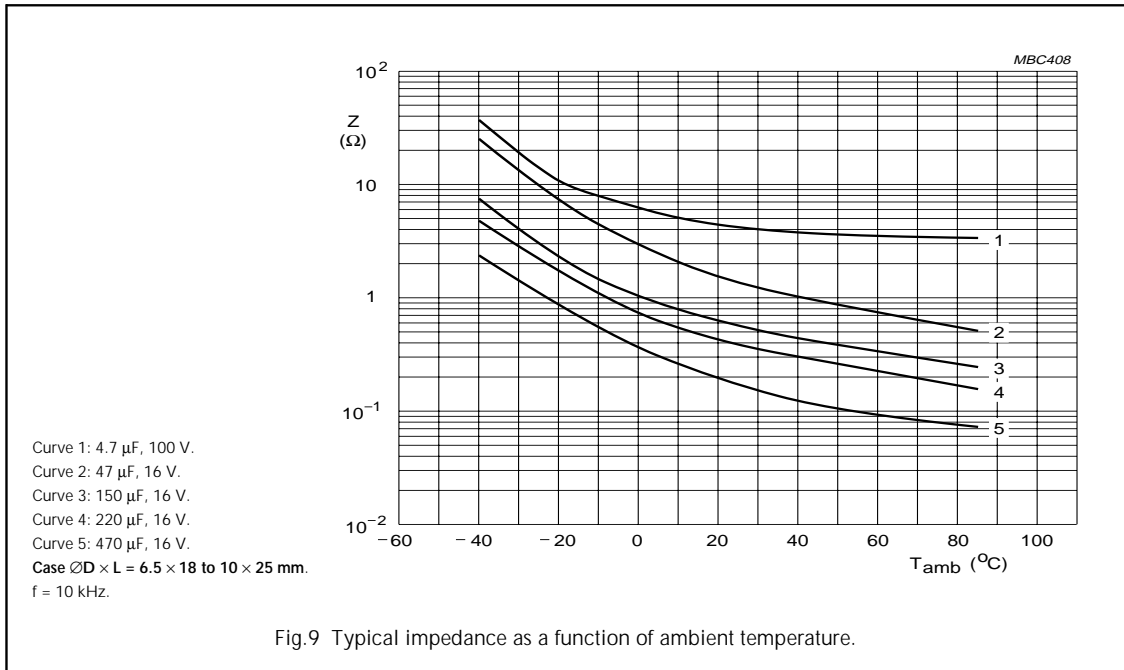

# Aluminum electrolytic capacitors

## Axial Long Life, DIN-based

132/133 ALL-DIN

### RIPPLE CURRENT AND USEFUL LIFE

**Table 4** Multiplier of ripple current ( $I_R$ ) as a function of frequency

FREQUENCY (Hz)	$I_R$ MULTIPLIER		
	$U_R = 10$ to $16$ V	$U_R = 25$ to $63$ V	$U_R = 100$ to $350$ V
50	0.95	0.9	0.85
100	1.0	1.0	1.0
300	1.07	1.12	1.2
1000	1.12	1.2	1.3
3000	1.15	1.25	1.35
$\geq 10000$	1.2	1.3	1.4

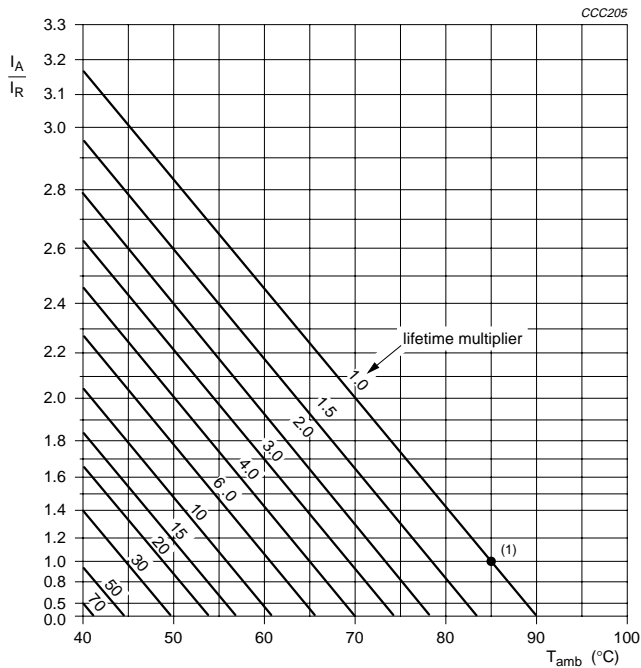

$I_A$  = actual ripple current at 100 Hz.  
 $I_R$  = rated ripple current at 100 Hz, 85 °C.  
 (1) Useful life at 85 °C and  $I_R$  applied;  
 case  $\varnothing D \times L = 6.5 \times 18$  and  $8 \times 18$  mm: 10000 hours  
 case  $\varnothing D \times L = 10 \times 18$  to  $21 \times 40$  mm: 15000 hours.

Fig.11 Multiplier of useful life as a function of ambient temperature and ripple current load.

# Aluminum electrolytic capacitors

## Axial Long Life, DIN-based

### 132/133 ALL-DIN

#### SPECIFIC TESTS AND REQUIREMENTS

General tests and requirements are specified in data handbook BC01, section "Tests and Requirements".

**Table 5** Test procedures and requirements

TEST		PROCEDURE (quick reference)	REQUIREMENTS
NAME OF TEST	REFERENCE		
Endurance	IEC 60384-4/ EN130300, subclause 4.13	$T_{amb} = 85\text{ °C}$ ; $U_R$ applied; case $\varnothing D \times L = 6.5 \times 18$ and $8 \times 18$ mm: 6000 hours; case $\varnothing D \times L = 10 \times 18$ to $21 \times 40$ mm: 8000 hours	$U_R = 10$ to $160\text{ V}$ ; $\Delta C/C$ : $\pm 15\%$ $U_R = 250$ to $350\text{ V}$ ; $\Delta C/C$ : $\pm 10\%$ $\tan \delta \leq 1.3 \times \text{spec. limit}$ $Z \leq 2 \times \text{spec. limit}$ $I_{L5} \leq \text{spec. limit}$
Useful life	CECC 30301, subclause 1.8.1	$T_{amb} = 85\text{ °C}$ ; $U_R$ and $I_R$ applied; case $\varnothing D \times L = 6.5 \times 18$ and $8 \times 18$ mm: 10000 hours; case $\varnothing D \times L = 10 \times 18$ to $21 \times 40$ mm: 15000 hours	$U_R = 10$ to $160\text{ V}$ ; $\Delta C/C$ : $\pm 45\%$ $U_R = 250$ to $350\text{ V}$ ; $\Delta C/C$ : $\pm 30\%$ $\tan \delta \leq 3 \times \text{spec. limit}$ $Z \leq 3 \times \text{spec. limit}$ $I_{L5} \leq \text{spec. limit}$ no short or open circuit total failure percentage: $\leq 1\%$
Shelf life (storage at high temperature)	IEC 60384-4/ EN130300, subclause 4.17	$T_{amb} = 85\text{ °C}$ ; no voltage applied; 500 hours after test: $U_R$ to be applied for 30 minutes, 24 to 48 hours before measurement	$\Delta C/C$ , $\tan \delta$ , $Z$ : for requirements see 'Endurance test' above $I_{L5} \leq 2 \times \text{spec. limit}$

#### MARKING

The capacitors are marked (where possible) with the following information:

- Rated capacitance (in  $\mu\text{F}$ )
- Tolerance on rated capacitance, code letter in accordance with "IEC 60062"
- Rated voltage (in V)
- Upper category temperature (85 °C)
- Group number (132 or 133)
- Name of manufacturer
- Date code, in accordance with "IEC 60062"
- Code indicating factory of origin
- Band to identify the negative terminal.