

AVAILABLE THROUGH DISTRIBUTION



BOURNS®

Features

- Surface Mount 4 mm Square / Multiturn Cermet / Industrial / Sealed
- Sealed to withstand board wash processing
- Pick and place centering design, with flush adjustment

- 4mm design meets EIA/EIAJ/IPC/VECI SMD standard trimmer footprint
- Low CRV - 1 %
- DESC selected material drawing #92021

3224 - 4 mm SMD Trimming Potentiometer

Electrical Characteristics

Standard Resistance Range 10 to 2 megohm
 (see standard resistance table)
 Resistance Tolerance ±10 % std.
 Absolute Minimum Resistance 1 % or 2.0 ohms
 (whichever is greater)
 Contact Resistance Variation 1 % or 3 ohms max.
 Resolution Essentially Infinite
 Insulation Resistance 500 vdc.
 100 megohms min.
 Dielectric Strength
 Sea Level 600 vac (1minute)
 Adjustment Angle 11 turns nom.

Environmental Characteristics

Power Rating (300 volts max.)
 85 °C 0.25 watt
 150 °C 0 watt
 Temperature Range -65 °C to +150 °C
 Temperature Coefficient ±100 ppm/°C
 Humidity MIL-STD 202 Method 106
 TRS ±2 %; IR 10 megohms
 Vibration 20 G TRS ±1 %; VRS ±1 %
 Shock 100 G TRS ±1 %; VRS ±1 %
 Load Life
 @ 85 °C rated power 1,000 hours
 TRS 3 ohms or 3 % (whichever is greater)
 Rotational Cycling 200 cycles
 TRS 3 ohms or 3 % (whichever is greater)
 Thermal Shock 5 cycles
 TRS ±2 %; VRS ±1 %

Physical Characteristics

Mechanical Stop Wiper idles
 Torque 180 g-cm max.
 Weight Approximately 0.01 oz.
 Marking Manufacturer's code,
 resistance code and date code
 Solderability Per MIL-STD-202,
 Method 208
 Wiper Set at 50 % nominal
 Flammability UL94V0
 Pushover Strength
 J, G 4.4 lbs.
 W, X 2.2 lbs.
 Adjustment Tool H-91

How To Order

3224 J - 1 - 502 E

Model _____
 Style _____
 Standard or Modified Product Indicator _____
 -1 = IR Reflow (standard)
 *-2 = Wave Solderable
 -FW5 = .070" ± .010" Shaft Extension
 Resistance Code _____
 Embossed Tape Designator _____
 E = Style J, G: 500 pcs./7" reel (standard)
 Style W: 250 pcs./7" reel (standard)
 Style X: 200 pcs./7" reel (standard)
 G = Style J, G: 1500 pcs./13" reel (standard)
 Style W: 1000 pcs./13" reel (standard)
 Style X: 850 pcs./13" reel (standard)
 G = Style J, G: 1500 pcs./13" reel (FW5)
 Style W, X: 600 pcs./13" reel (FW5)

Consult factory for other available options.
 * -2 has a treated stainless steel shaft

3224J Side Adjust

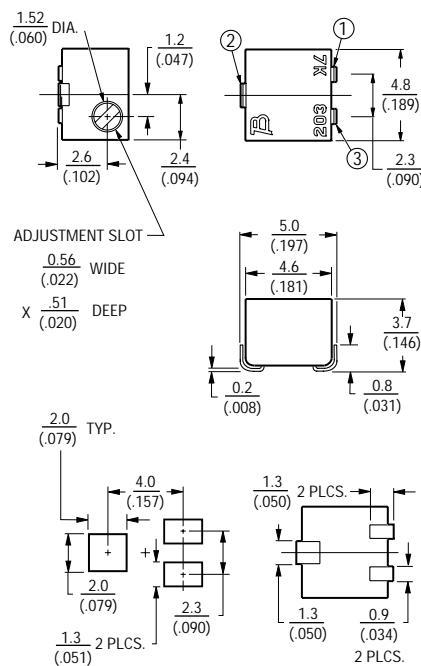

3224G Side Adjust

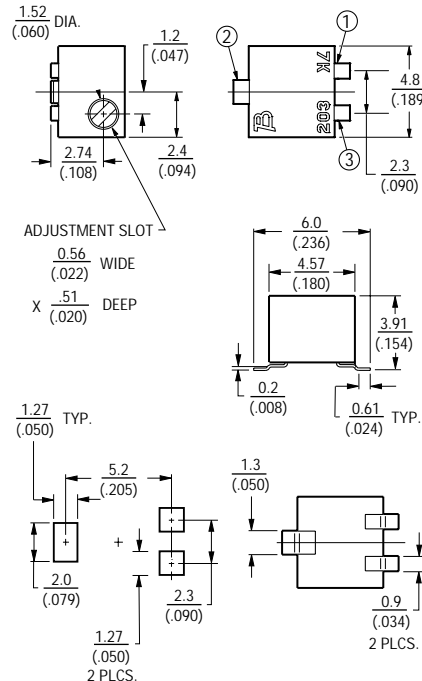

3224W Top Adjust

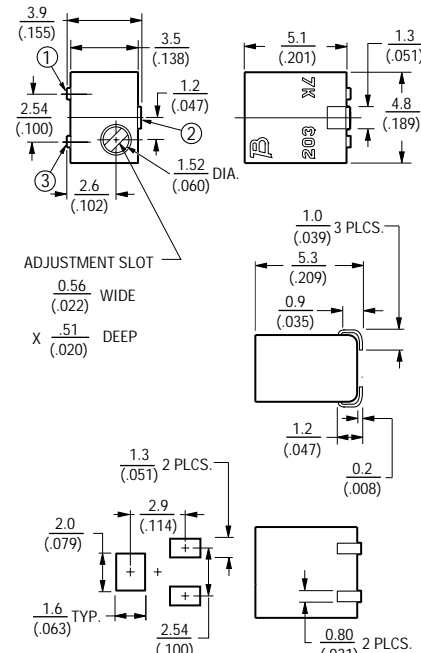

3224X Top Adjust

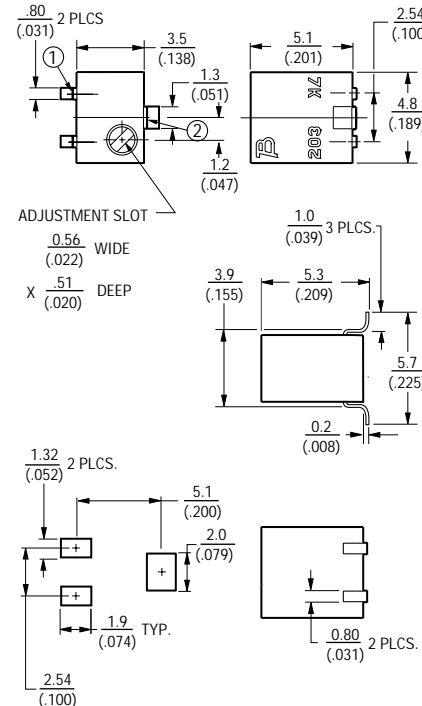

Specifications are subject to change without notice.

Customers should verify actual device performance in their specific applications.

Additional Features

- Top and side adjust styles
- J-hook, and gull-wing
- Patent #5047746 advanced drive/wiper mechanism

3224 - Packaging Specifications

BOURNS®

J & G Styles

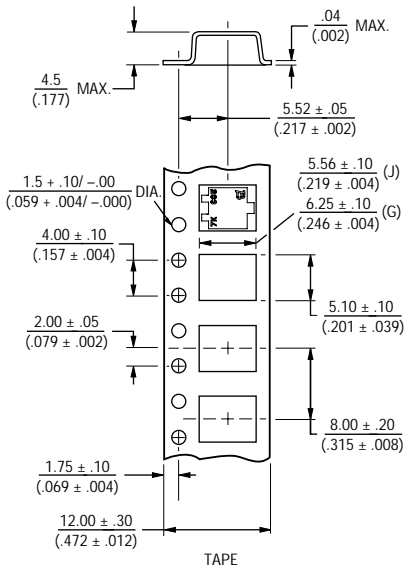

W Style

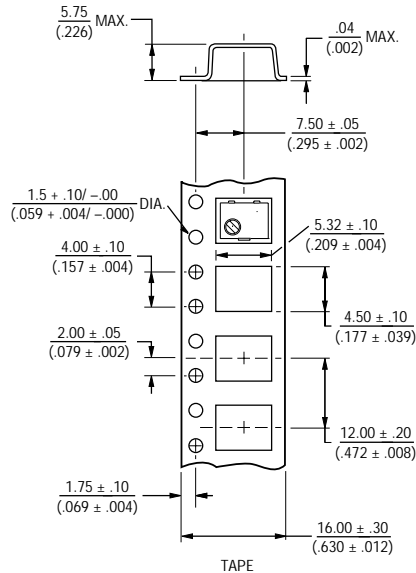

X Style

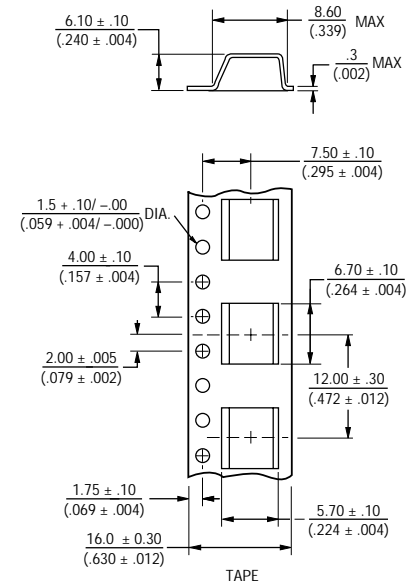

W & X Style Reel

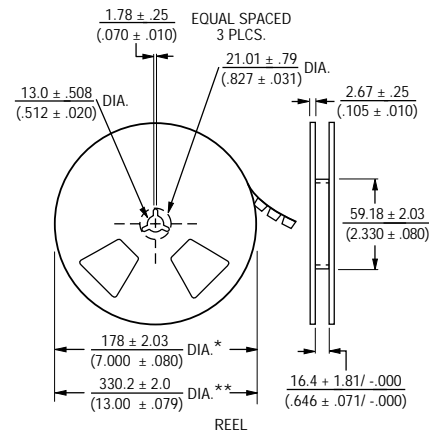
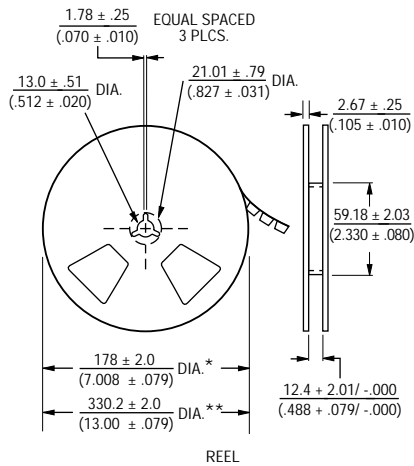

* Embossed Tape Designator "E"
 ** Embossed Tape Designator "G"
 (See How To Order chart for further information.)

Cover tape peel strength: Meets EIA specification 481.

* Embossed Tape Designator "E"
 ** Embossed Tape Designator "G"
 (See How To Order chart for further information.)

Cover tape peel strength: Meets EIA specification 481.

TOLERANCES: ± 0.25 (.010) EXCEPT WHERE NOTED

DIMENSIONS ARE: $\frac{\text{MM}}{\text{(INCHES)}}$

Standard Resistance Table

Resistance (Ohms)	Resistance Code
10	100
20	200
50	500
100	101
200	201
500	501
1,000	102
2,000	202
5,000	502
10,000	103
20,000	203
50,000	503
100,000	104
200,000	204
500,000	504
1,000,000	105
2,000,000	205

Popular distribution resistance values listed in boldface. Special resistances available.

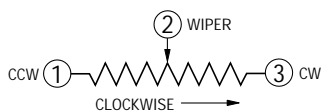

REV. 06/03

Specifications are subject to change without notice.

Customers should verify actual device performance in their specific applications.