

Digital Optocouplers for Ultra Low Power and High Noise Rejection

Application Note 5486

Introduction

Avago’s new-generation optocouplers, ACPL-M61L/M62L/061L/064L/W61L/K64L (ACPL-x6xL) and ACNW261L offer significant power efficiency improvements—a critical design parameter for electrical system designers. These new optocouplers consume 90% less power than standard optocouplers available today and 40% lower power than alternative opto-isolators.

Optocouplers provide high-voltage insulation and noise rejection—two essential requirements for transmitting information from one voltage potential to another within an electrical system. Electrical equipment, especially equipment used in industrial applications, must operate reliably for many years. Hence, the optocoupler must provide a high-quality insulation barrier to ensure reliability and durability. In addition, optocouplers reject common mode transient noise that can cause abnormal voltage transitions or excessive noise on the output signal.

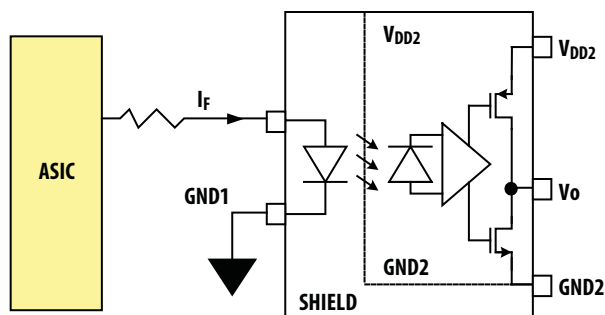

Figure 1. ACPL-M61L directly driven from ASIC without external buffer.

Target Applications and Key Features

The ACPL-x6xL and ACNW261L are designed for communication interfaces (RS485, CANBus, and I2C), microprocessor system interfaces, and provide digital isolation for A/D and/or D/A conversion applications. Device performance is guaranteed over a wide temperature range, from -40°C to 105°C, making them ideal for industrial applications.

Key features of the ACPL-x6xL and ACNW261L include:

- A low-current LED input that allows direct drive from CMOS outputs (refer to Figure 1)
- 35 kV/ μ s dynamic and static common mode rejection - no compromise on noise immunity!
- Controlled output slew rate over a wide range of load conditions
- Easy configuration for inverting and non-inverting operation
- Certified for safe insulation at continuous working voltages from 560V_{peak} to 1414V_{peak} with transient voltages of 6kV_{peak} / 8kV_{peak}

Table 1 presents essential technical specifications for these optocouplers.

Table 1. Key technical specifications of ACPL-x6xL and ACNW261L.

Parameter	Specification
Propagation Delay	80 ns (max)
Skew between any two parts	30 ns (max)
Pulse Width Distortion	30 ns (max)
LED Forward Current	1.6 mA
I _{cc} Supply Current	1.3 mA (max)
Common Mode Noise Rejection	35 kV/ μ s at 1000 V
Supply Voltage	2.7 to 5.5 V
Temperature Range	-40 to 105°C
Continuous Working Voltage	560 V _{peak} to 1414 V _{peak}

Ease of Use and Design Flexibility

As previously mentioned, the low LED current needed to switch the new optocouplers series makes it possible to drive the input LED directly from a CMOS output. To simplify circuit design in these cases, Avago specifies all timing parameters for the new optocouplers with fixed input resistor configurations for 3.3V and 5V signal levels (across the temperature range). Moreover, the push-pull CMOS outputs eliminate the need for external pull-up resistors.

The output stage is inverting but designers can easily configure the optocouplers for either inverting or non-inverting operation. In Figure 2 below, to obtain a non-inverting configuration the designer must simply change V_{in} to V_{cc} and $GND1$ to V_{in} .

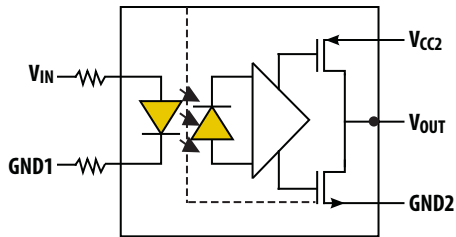

Figure 2. Typical high-CMR drive circuit.

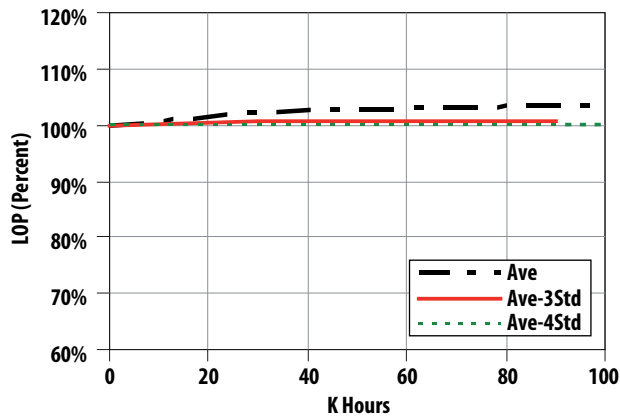

Figure 3. LED light output power, LOP, stability over time.

Optocoupler CMR Performance

Common mode noise can create a significant problem in data communication applications, especially in industrial environments where electrical motors, sensors and programmable logic controllers are connected together. In such systems, isolators reduce noise levels and enhance signal performance. All isolators, regardless of technology, have a parasitic capacitive coupling between the two isolated sides of the component. A noise transient occurring on the output side may cause an unwanted voltage rise on the input side. This can result in false-triggering of the input or even latch-up of high-impedance logic inputs. Optical isolators with LED inputs are ideal in environments with high levels of common mode noise.

The attenuation of the light signal through the internal, optically transparent insulation material in these optocouplers is low, so the distance through isolator can be kept high, effectively reducing the parasitic capacitance. In other words, providing sufficient insulation thickness in these optocoupler minimizes the unwanted capacitive coupling between the two sides.

The “split resistor” input LED drive approach shown in Figure 2 balances the impedance across the LED input. Thus, a common mode noise voltage rise on the LED is symmetrical and cannot, therefore, switch the LED on. In addition, the LED inputs have a relatively high input capacitance of 70pF. The series-connected LED and current-limiting resistor form a low-pass filter that helps filter noise transients. An internal Faraday shield also minimizes the effects of common mode noise.

High Reliability

The quality of the LED used in an optocoupler figures prominently in the durability of the product. Avago produces its own high-reliability LEDs for optocouplers at its manufacturing facility. The infrared, AlGaAs LED used in the ACPL-x6xL and ACNW261L provides excellent stability over both temperature and time. As shown in Figure 3, light output power (LOP) is essentially unchanged after 100,000 hours of operation. Graphs showing performance over temperature are provided in the product data sheets.

Speed Enhancement

A peaking capacitor placed across the input current-limit resistor (Figure 4) enhances speed performance. The value of the peaking capacitor is dependent upon the rise and fall time of the input signal and supply voltages and the LED input driving current (IF). Figure 5 shows the significant improvement of propagation delay and pulse width distortion (PWD) achieved by adding a peaking capacitor with a driving current of 2mA and a 3.3V/5V power supply.

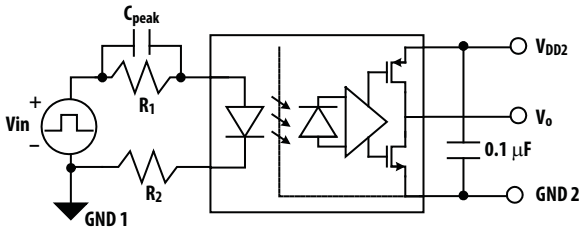

Figure 4. Connection of peaking capacitor (C_{peak}) in parallel of the input limiting resistor ($R1$) to improve speed performance

Benefits from Slew-rate Controlled Outputs

The maximum data rate for a serial interface is limited by the skew/synchronization between signals on the data and clock lines rather than the optocoupler's absolute propagation delay. Increasing the absolute switching speed of an isolator decreases noise rejection. Rather than reducing propagation delay, Avago leverages new design features in its optocouplers that reduce skew and enhance signal quality by controlling the output slew rate.

Differences in line capacitance can lead to differences in rise and fall times between two channels. Output nodes that have higher load capacitance will have higher rise and fall times (as depicted in Figure 6). This results in a large variation of propagation delay, PWD and propagation delay skew performance. The ACPL-x6xL and ACNW261L are designed with a slew-rate controlled output feature. This feature allows the rise and fall time of the output signal to be well controlled across a wide load capacitance range. This is important in parallel communication where different communication lines (for example clock and signal lines) may have different fan-outs. The propagation delay difference (skew) between any two channels in the ACPL-x6xL and ACNW261L is specified at 30ns maximum over temperature.

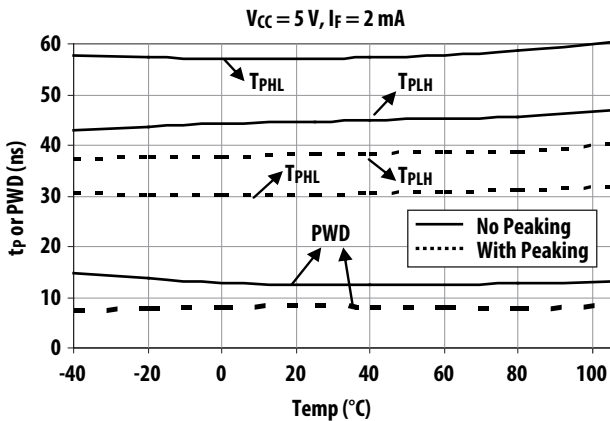

Figure 5. Improvement of t_p and PWD with the addition of a 47pF peaking capacitor.

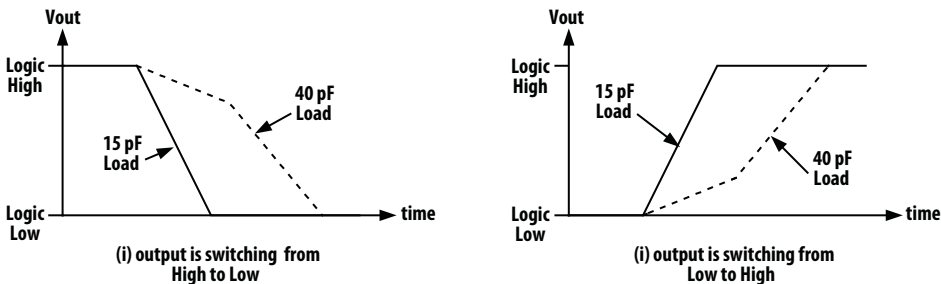

Figure 6. Rise and fall times of the output varying with load capacitance.

Supply Voltage Range and Glitch-Free Outputs

Besides being power efficient, ACPL-x6xL and ACNW261L are able to deliver stable switching performance across the whole supply voltage range (2.7 V – 5.5 V) and glitch free outputs during power up/down of the component.

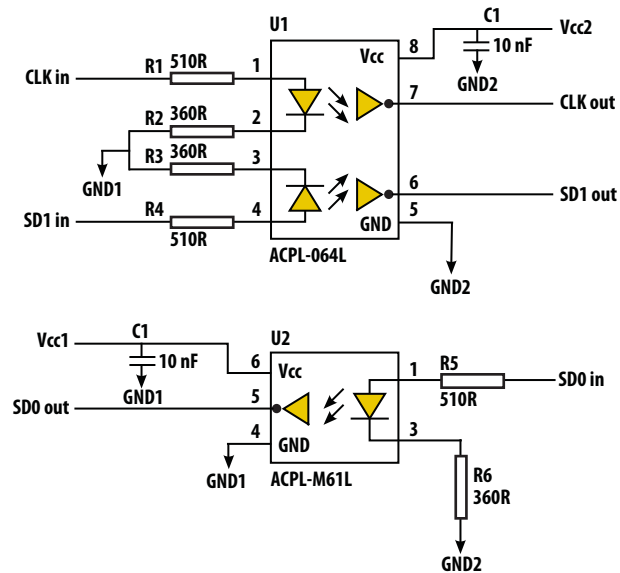

Figure 7. Isolation of SPI interface.

Application Example: SPI Interface

In many applications, such as SPI and I2C serial interfaces, stable switching parameters over time and temperature are far more important than the actual device switching speed. The SPI serial interface found in many micro-controllers is a good example to review. An isolated SPI interface based on the dual-channel ACPL-064L and the single-channel ACPL-M61L is shown in Figure 7. Figure 8 shows the ACPL-x6xL SPI interface evaluation board that is available upon request from Avago.

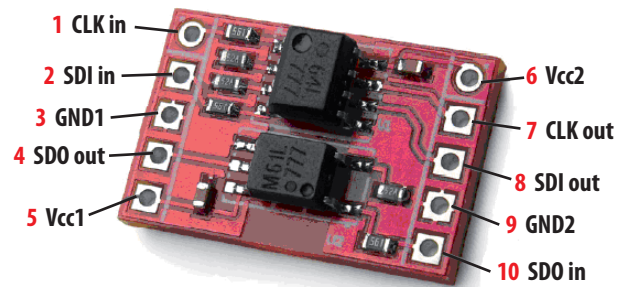

Figure 8. ACPL-x6xL SPI interface evaluation board.

Product Offering

Table 2 and Figure 9 below show the various package options available. All devices are RoHS-6 compliant.

Table 2. ACPL-x6xL and ACNW261L package options

Part No.	Package Type	No. of Channels	Output Type	Enable Pin	UL1577, 1 min (Vpeak)	IEC60747-5-5, Max. Working Voltage (Vpeak)	Clearance (mm)	Creepage (mm)
ACPL-M61L	SO-5	1	CMOS	–	3750	560*	5.0	5.0
ACPL-M62L [^]	SO-5	1	Open Drain	–	3750	560*	5.0	5.0
ACPL-061L [^]	SO-8	1	CMOS	0	3750	560*	4.9	4.8
ACPL-064L	SO-8	2	CMOS	–	3750	560*	4.9	4.8
ACPL-W61L	Stretched S06	1	CMOS	–	5000	1140*	8.0	8.0
ACPL-K64L	Stretched S08	2	CMOS	–	5000	1140*	8.0	8.0
ACNW261L [^]	400 mil DIP-8/ Gull Wing	1	CMOS	0	5000	1414	9.6	10.0

Notes:

[^] Advance information. Subjected to changes.

* Applicable for ACPL-x6xL series with IEC60747-5-5 Option, -x60E.

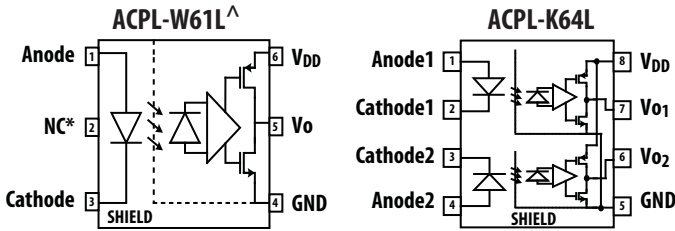
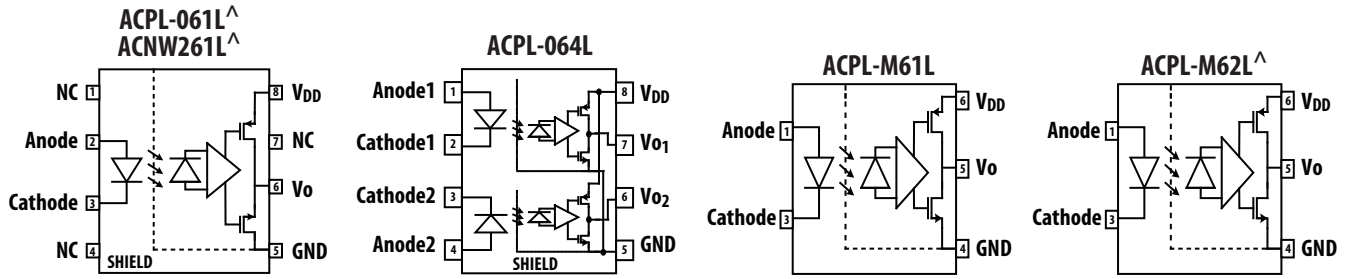

TRUTH TABLE
(POSITIVE LOGIC)

LED	OUTPUT
ON	L
OFF	H

TRUTH TABLE
(POSITIVE LOGIC)

LED	ENABLE	OUTPUT
ON	H	L
OFF	H	H
ON	L	Z
OFF	L	Z
ON	NC	L
OFF	NC	H

(for ACPL-061L/ACNW261L only)

* A 0.1 μ F bypass capacitor must be connected between pins V_{DD} and GND.
 ^ Advanced information, may subject to changes.

Figure 9. ACPL-x6xL and ACNW261L package options

For product information and a complete list of distributors, please go to our web site: www.avagotech.com