

MM74HC4040

12-Stage Binary Counter

Features

- Typical propagation delay: 16ns
- Wide operating voltage range: 2–6V
- Low input current: 1µA Max.
- Low quiescent current: 80µA Max. (74HC Series)
- Output drive capability: 10 LS-TTL loads

General Description

The MM74HC4040 is a high speed binary ripple carry counter. This counter is implemented utilizing advanced silicon-gate CMOS technology to achieve speed performance similar to LS-TTL logic while retaining the low power and high noise immunity of CMOS.

The MM74HC4040 is a 12-stage counter. This device is incremented on the falling edge (negative transition) of the input clock, and all their outputs are reset to a low level by applying a logical high on their reset input.

This device is pin equivalent to the CD4040. All inputs are protected from damage due to static discharge by protection diodes to V_{CC} and ground.

Ordering Information

Order Number	Package Number	Package Description
MM74HC4040M ⁽¹⁾	M16A	16-Lead Small Outline Integrated Circuit (SOIC), JEDEC MS-012, 0.150" Narrow
MM74HC4040SJ ⁽¹⁾	M16D	16-Lead Small Outline Package (SOP), EIAJ TYPE II, 5.3mm Wide
MM74HC4040MTC ⁽¹⁾	MTC16	16-Lead Thin Shrink Small Outline Package (TSSOP), JEDEC MO-153, 4.4mm Wide
MM74HC4040N	N16E	16-Lead Plastic Dual-In-Line Package (PDIP), JEDEC MS-001, 0.300" Wide

Note:

1. Devices also available in Tape and Reel. Specify by appending the suffix letter "X" to the ordering number.

Connection Diagram

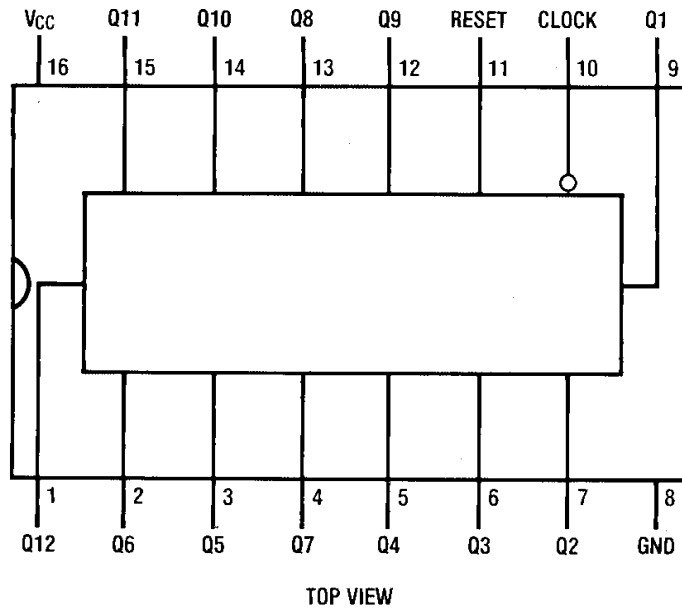

Logic Diagram

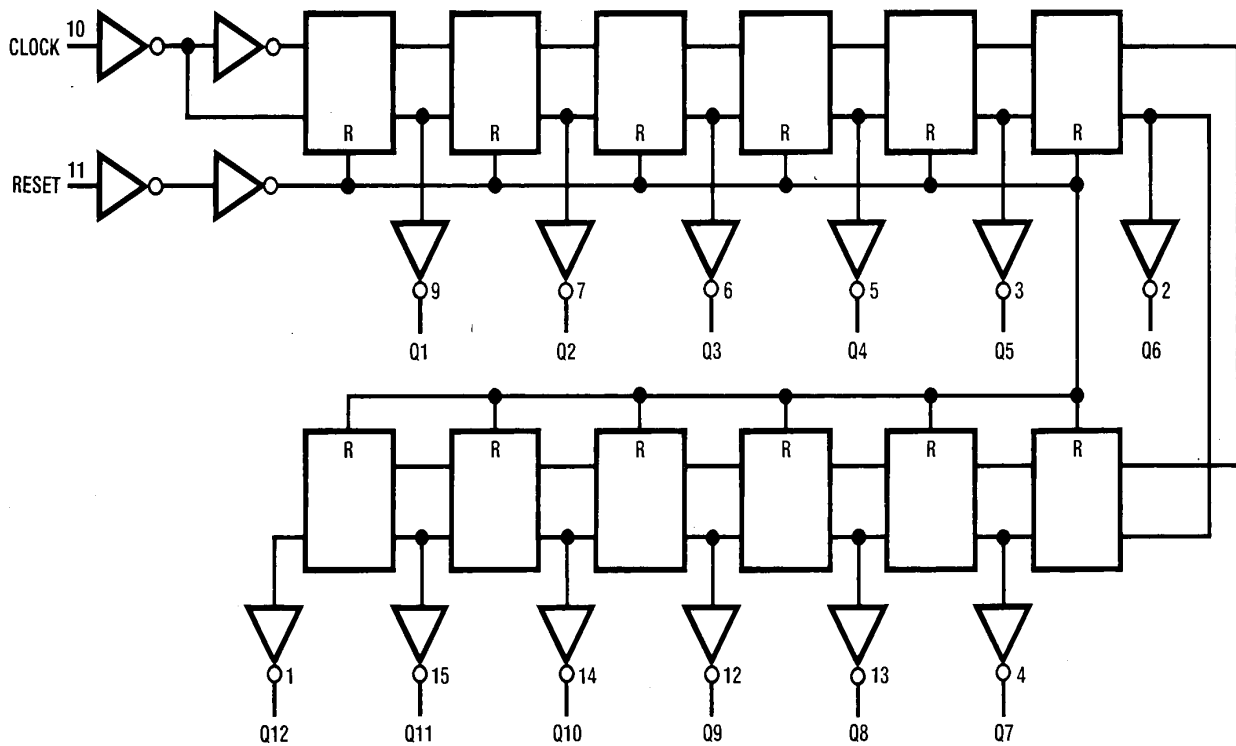

Absolute Maximum Ratings⁽²⁾

Stresses exceeding the absolute maximum ratings may damage the device. The device may not function or be operable above the recommended operating conditions and stressing the parts to these levels is not recommended. In addition, extended exposure to stresses above the recommended operating conditions may affect device reliability. The absolute maximum ratings are stress ratings only.

Symbol	Parameter	Rating
V_{CC}	Supply Voltage	-0.5 to +7.0V
V_{IN}	DC Input Voltage	-1.5 to $V_{CC} + 1.5V$
V_{OUT}	DC Output Voltage	-0.5 to $V_{CC} + 0.5V$
I_{CD}	Clamp Diode Current	$\pm 20mA$
I_{OUT}	DC Output Current, per pin	$\pm 25mA$
I_{CC}	DC V_{CC} or GND Current, per pin	$\pm 50mA$
T_{STG}	Storage Temperature Range	-65°C to +150°C
P_D	Power Dissipation Note 3 S.O. Package only	600mW 500mW
T_L	Lead Temperature (Soldering 10 seconds)	260°C

Note:

- Unless otherwise specified all voltages are referenced to ground.
- Power Dissipation temperature derating — plastic "N" package: -12mW/°C from 65°C to 85°C.

Recommended Operating Conditions

The Recommended Operating Conditions table defines the conditions for actual device operation. Recommended operating conditions are specified to ensure optimal performance to the datasheet specifications. Fairchild does not recommend exceeding them or designing to absolute maximum ratings.

Symbol	Parameter	Min.	Max.	Units
V_{CC}	Supply Voltage	2	6	V
V_{IN}, V_{OUT}	DC Input or Output Voltage	0	V_{CC}	V
T_A	Operating Temperature Range	-40	+85	°C
t_r, t_f	Input Rise and Fall Times $V_{CC} = 2.0V$ $V_{CC} = 4.5V$ $V_{CC} = 6.0V$		1000 500 400	ns

DC Electrical Characteristics⁽⁴⁾

Symbol	Parameter	Conditions	V _{CC}	T _A = 25°C		T _A = -40 to 85°C	T _A = -55 to 125°C	Units
				Typ.	Guaranteed Limits			
V _{IH}	Minimum HIGH Level Input Voltage		2.0V		1.5	1.5	1.5	V
			4.5V		3.15	3.15	3.15	
			6.0V		4.2	4.2	4.2	
V _{IL}	Maximum LOW Level Input Voltage		2.0V		0.5	0.5	0.5	V
			4.5V		1.35	1.35	1.35	
			6.0V		1.8	1.8	1.8	
V _{OH}	Minimum HIGH Level Output Voltage	V _{IN} = V _{IH} or V _{IL} : I _{OUT} ≤ 20 μA	2.0V	2.0	1.9	1.9	1.9	V
			4.5V	4.5	4.4	4.4	4.4	
			6.0V	6.0	5.9	5.9	5.9	
		V _{IN} = V _{IH} or V _{IL} : I _{OUT} ≤ 4.0 mA	4.5V	4.2	3.98	3.84	3.7	
			6.0V	5.7	5.48	5.34	5.2	
V _{OL}	Maximum LOW Level Output Voltage	V _{IN} = V _{IH} or V _{IL} : I _{OUT} ≤ 20 μA	2.0V	0	0.1	0.1	0.1	V
			4.5V	0	0.1	0.1	0.1	
			6.0V	0	0.1	0.1	0.1	
		V _{IN} = V _{IH} or V _{IL} : I _{OUT} ≤ 4.0 mA	4.5V	0.2	.26	0.33	0.4	
			6.0V	0.2	.26	0.33	0.4	
I _{IN}	Maximum Input Current	V _{IN} = V _{CC} or GND	6.0V		±0.1	±1.0	±1.0	μA
I _{CC}	Maximum Quiescent Supply Current	V _{IN} = V _{CC} or GND, I _{OUT} = 0 μA	6.0V		8.0	80	160	μA

Note:

4. For a power supply of 5V ±10% the worst case output voltages (V_{OH}, and V_{OL}) occur for HC at 4.5V. Thus the 4.5V values should be used when designing with this supply. Worst case V_{IH} and V_{IL} occur at V_{CC} = 5.5V and 4.5V respectively. (The V_{IH} value at 5.5V is 3.85V.) The worst case leakage current (I_{IN}, I_{CC}, and I_{OZ}) occur for CMOS at the higher voltage and so the 6.0V values should be used.

AC Electrical Characteristics

V_{CC} = 5V, T_A = 25°C, C_L = 15pF, t_r = t_f = 6ns

Symbol	Parameter	Conditions	Typ.	Guaranteed Limit	Units
f _{MAX}	Maximum Operating Frequency		50	30	MHz
t _{PHL} , t _{PLH}	Maximum Propagation Delay Clock to Q	⁽⁵⁾	17	35	ns
t _{PHL}	Maximum Propagation Delay Reset to any Q		16	40	ns
t _{REM}	Minimum Reset Removal Time		10	20	ns
t _W	Minimum Pulse Width		10	16	ns

Note:

5. Typical Propagation delay time to any output can be calculated using: t_p = 17 + 12(N-1) ns; where N is the number of the output, Q_W, at V_{CC} = 5V.

AC Electrical Characteristics

$V_{CC} = 2.0V$ to $6.0V$, $C_L = 50pF$, $t_r = t_f = 6ns$ (unless otherwise specified).

Symbol	Parameter	Conditions	V_{CC}	$T_A = 25^\circ C$		$T_A = -40$	$T_A = -55$	Units
				Typ	Guaranteed Limits		to $85^\circ C$	
f_{MAX}	Maximum Operating Frequency		2.0V	10	6	5	4	MHz
			4.5V	40	30	24	20	
			6.0V	50	35	28	24	
t_{PHL}, t_{PLH}	Maximum Propagation Delay Clock to Q_1		2.0V	80	210	265	313	ns
			4.5V	21	42	53	63	
			6.0V	18	36	45	53	
t_{PHL}, t_{PLH}	Maximum Propagation Delay Between Stages from Q_n to Q_{n+1}		2.0V	80	125	156	188	ns
			4.5V	18	25	31	38	
			6.0V	15	21	26	31	
t_{PHL}	Maximum Propagation Delay Reset to any Q (4020 and 4040)		2.0V	72	240	302	358	ns
			4.5V	24	48	60	72	
			6.0V	20	41	51	61	
t_{REM}	Minimum Reset Removal Time		2.0V		100	126	149	ns
			4.5V		20	25	50	
			6.0V		16	21	25	
t_W	Minimum Pulse Width		2.0V		90	100	120	ns
			4.5V		16	20	24	
			6.0V		14	18	20	
t_{TLH}, t_{THL}	Maximum Output Rise and Fall Time		2.0V	30	75	95	110	ns
			4.5V	10	15	19	22	
			6.0V	9	13	16	19	
t_r, t_f	Maximum Input Rise and Fall Time				1000	1000	1000	ns
					500	500	500	
					400	400	400	
C_{PD}	Power Dissipation Capacitance ⁽⁶⁾	(per package)		55				pF
C_{IN}	Maximum Input Capacitance			5	10	10	10	pF

Note:

6. C_{PD} determines the no load dynamic power consumption, $P_D = C_{PD} V_{CC}^2 f + I_{CC} V_{CC}$, and the no load dynamic current consumption, $I_S = C_{PD} V_{CC} f + I_{CC}$.

Timing Diagram

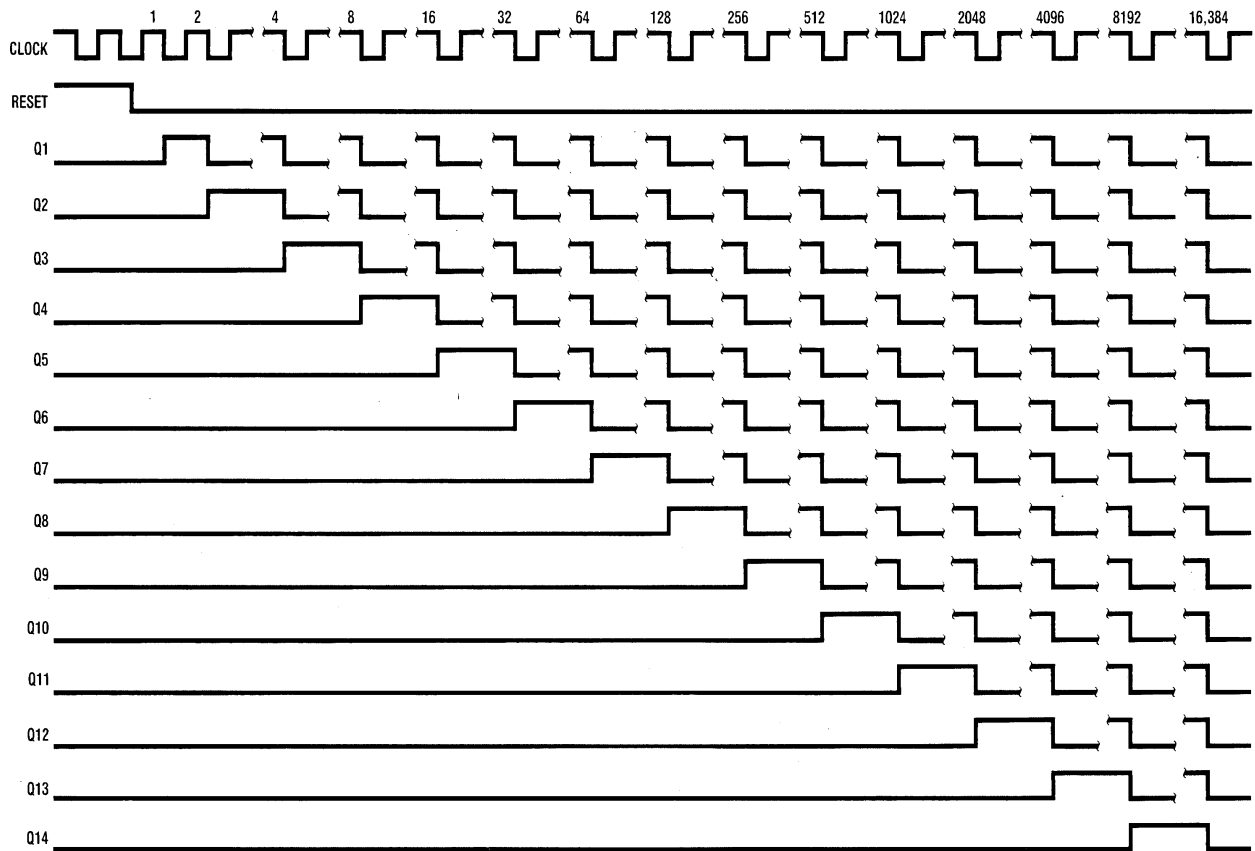

Physical Dimensions

Dimensions are in millimeters unless otherwise noted.

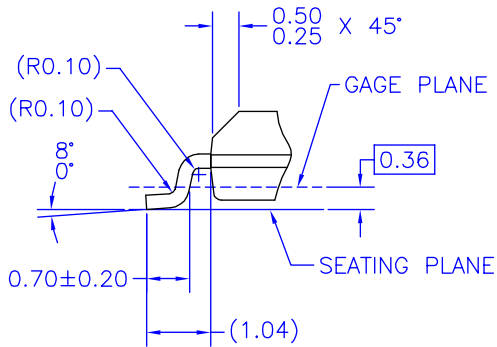
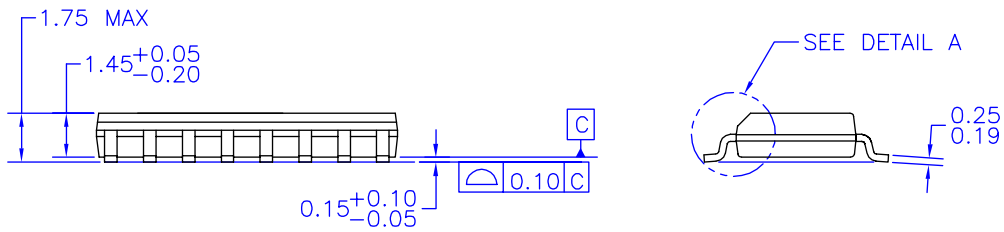
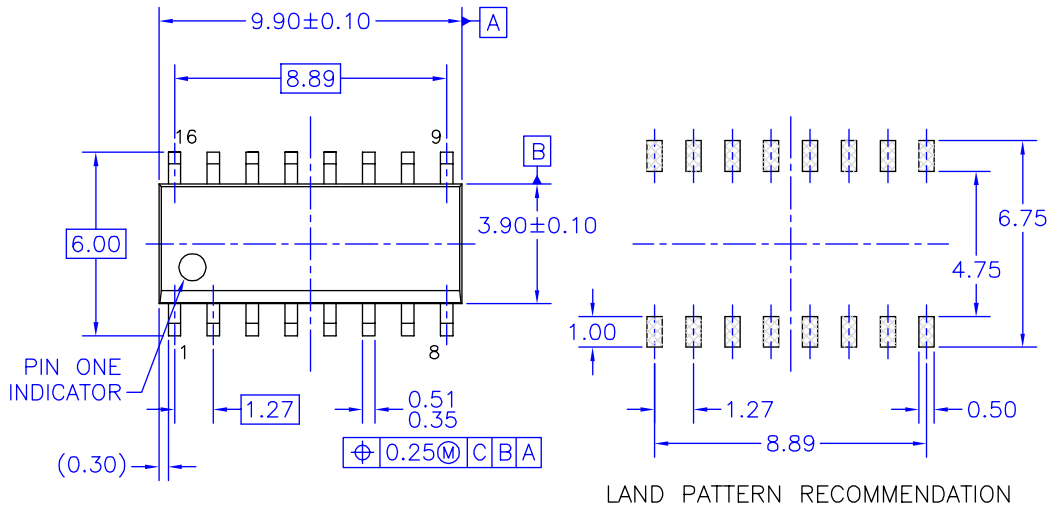

NOTES: UNLESS OTHERWISE SPECIFIED

- A) THIS PACKAGE CONFORMS TO JEDEC MS-012, VARIATION AC, ISSUE C, DATED MAY 1990.
- B) ALL DIMENSIONS ARE IN MILLIMETERS.
- C) DIMENSIONS DO NOT INCLUDE MOLD FLASH OR BURRS.
- D) STANDARD LEAD FINISH: 200 MICRONS / 5.08 MICRONS MIN. LEAD/TIN (SOLDER) ON COPPER.

DETAIL A
SCALE: 2:1

M16AREVK

Figure 1. 16-Lead Small Outline Integrated Circuit (SOIC), JEDEC MS-012, 0.150" Narrow Package Number M16A

Physical Dimensions (Continued)

Dimensions are in millimeters unless otherwise noted.

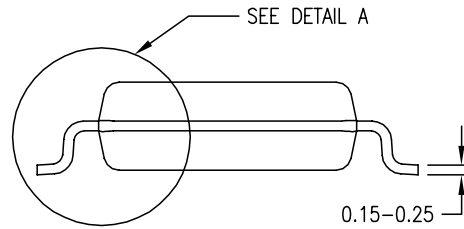
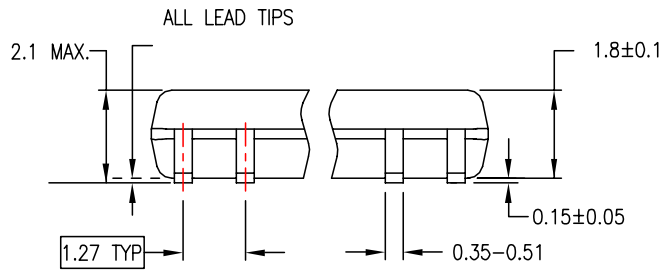
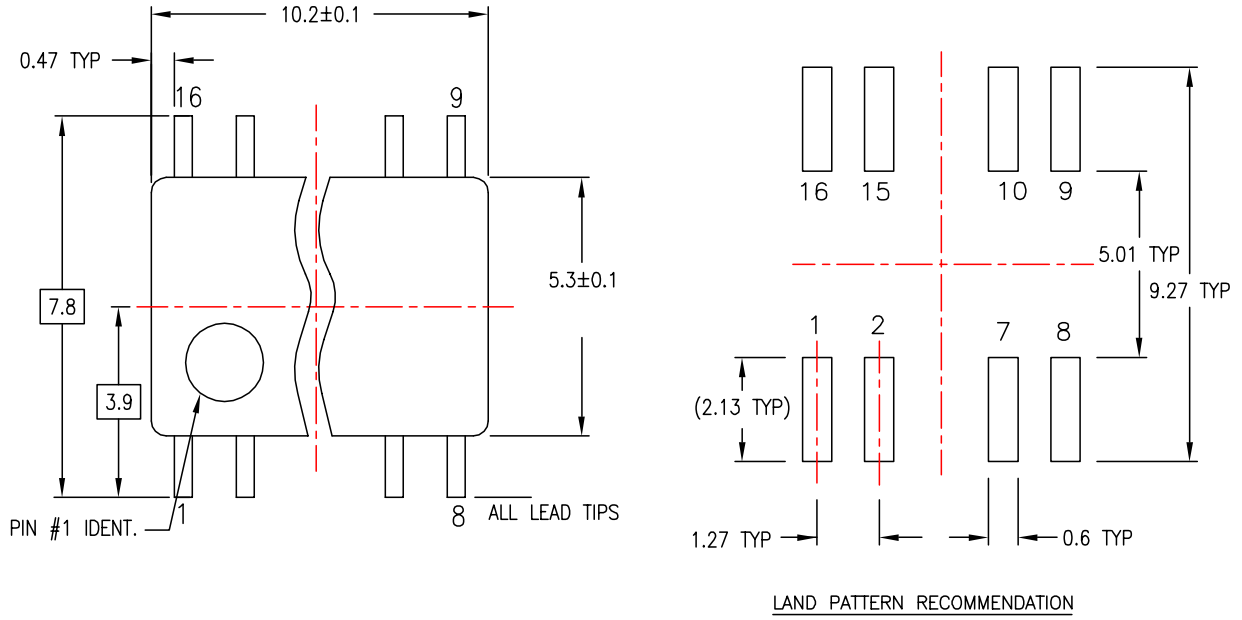

DIMENSIONS ARE IN MILLIMETERS

NOTES:

- A. CONFORMS TO EIAJ EDR-7320 REGISTRATION, ESTABLISHED IN DECEMBER, 1998.
- B. DIMENSIONS ARE IN MILLIMETERS.
- C. DIMENSIONS ARE EXCLUSIVE OF BURRS, MOLD FLASH, AND TIE BAR EXTRUSIONS.

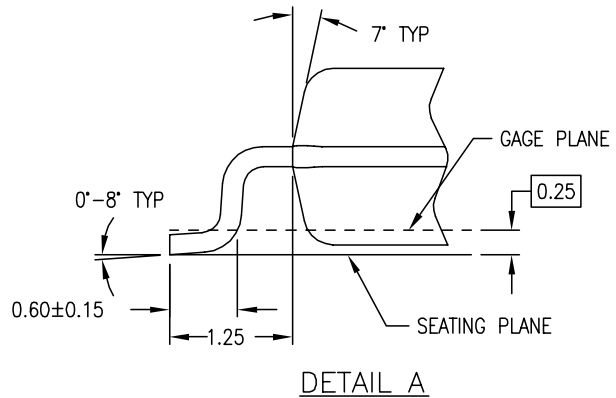

M16DREVC

Figure 2. 16-Lead Small Outline Package (SOP), EIAJ TYPE II, 5.3mm Wide Package Number M16D

Physical Dimensions (Continued)

Dimensions are in millimeters unless otherwise noted.

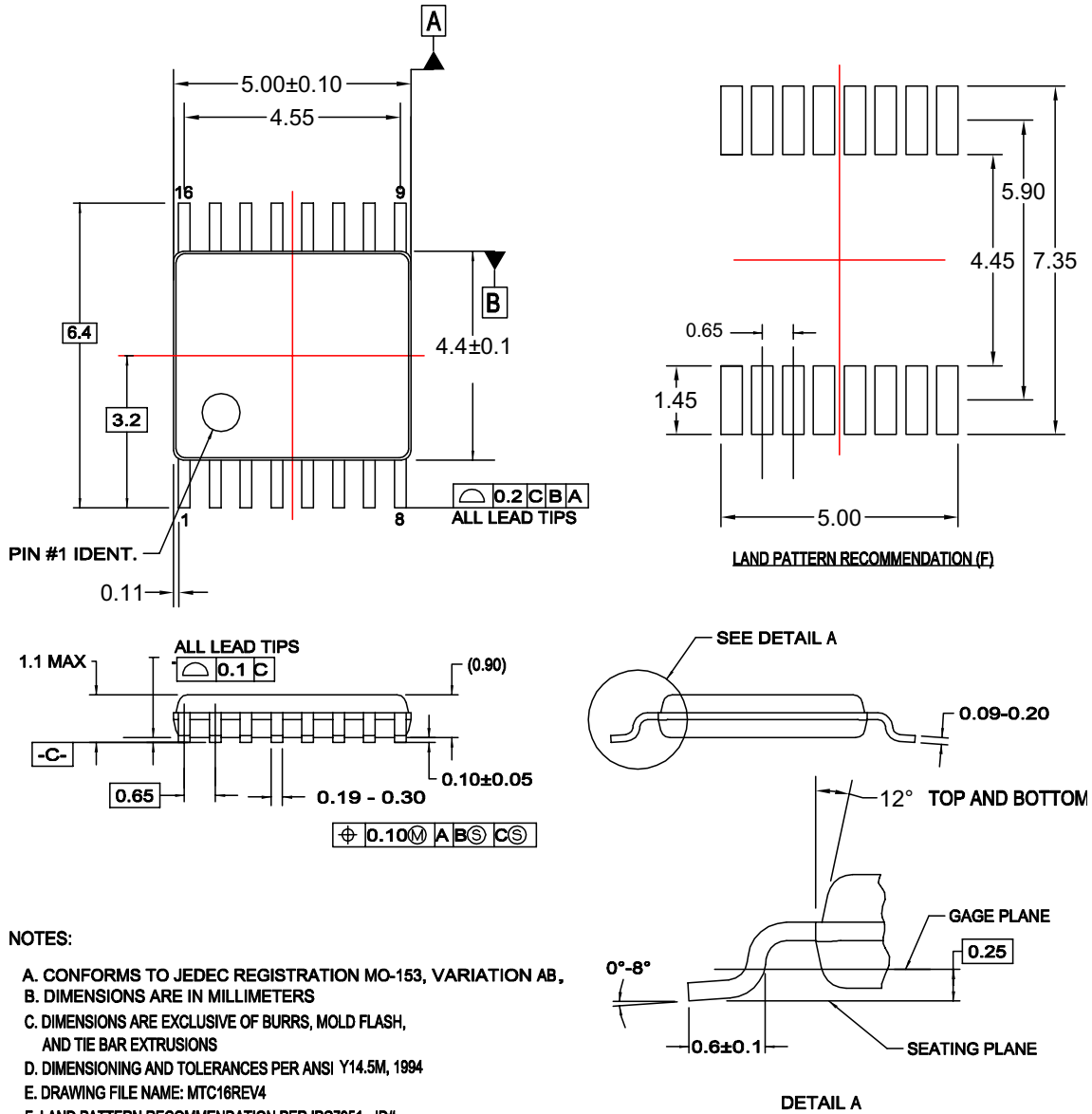

NOTES:

- A. CONFORMS TO JEDEC REGISTRATION MO-153, VARIATION AB,
- B. DIMENSIONS ARE IN MILLIMETERS
- C. DIMENSIONS ARE EXCLUSIVE OF BURRS, MOLD FLASH, AND TIE BAR EXTRUSIONS
- D. DIMENSIONING AND TOLERANCES PER ANSI Y14.5M, 1994
- E. DRAWING FILE NAME: MTC16REV4
- F. LAND PATTERN RECOMMENDATION PER IPC7351 - ID# TSOP65P640X110-16N

MTC16rev4

Figure 3. 16-Lead Thin Shrink Small Outline Package (TSSOP), JEDEC MO-153, 4.4mm Wide Package Number MTC16

Physical Dimensions (Continued)

Dimensions are in inches (millimeters) unless otherwise noted.

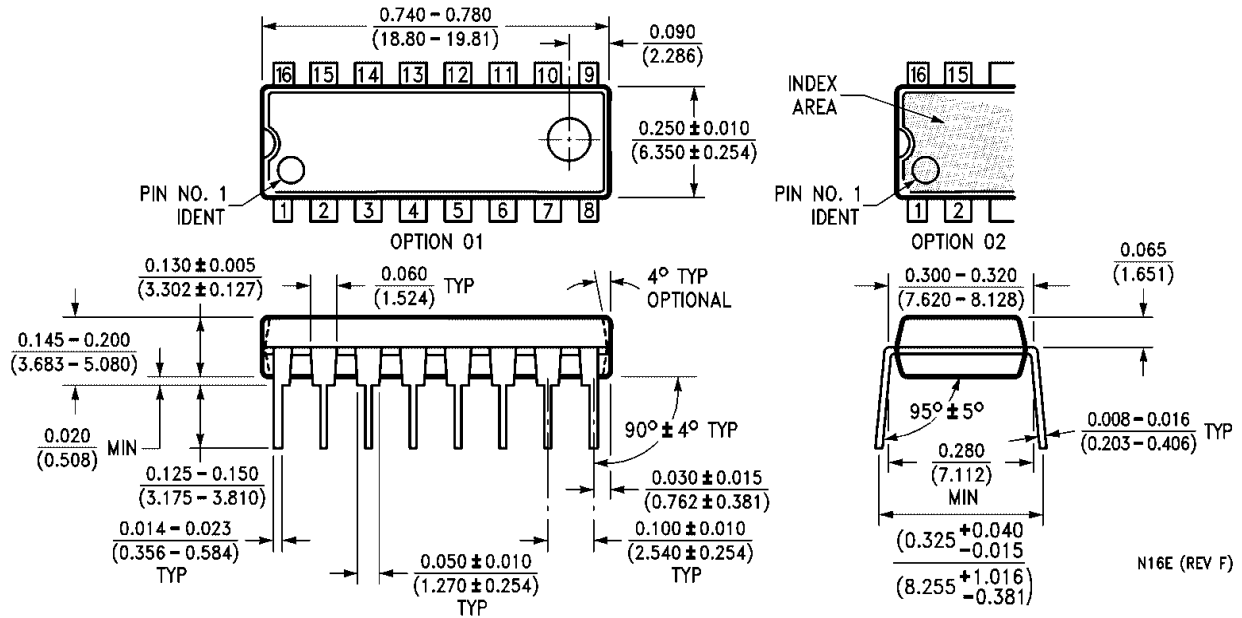



Figure 4. 16-Lead Plastic Dual-In-Line Package (PDIP), JEDEC MS-001, 0.300" Wide Package Number N16E

N16E (REV F)



TRADEMARKS

The following are registered and unregistered trademarks and service marks Fairchild Semiconductor owns or is authorized to use and is not intended to be an exhaustive list of all such trademarks

ACEx®	Green FPS™ e-Series™	Power-SPM™	SyncFET™
Build it Now™	GTO™	PowerTrench®	The Power Franchise®
CorePLUS™	<i>i-Lo</i> ™	Programmable Active Droop™	 ™
CROSSVOLT™	IntelliMAX™	QFET®	TinyBoost™
CTL™	ISOPLANAR™	QS™	TinyBuck™
Current Transfer Logic™	MegaBuck™	QT Optoelectronics™	TinyLogic®
EcoSPARK®	MICROCOUPLER™	Quiet Series™	TINYOPTO™
FACT Quiet Series™	MicroPak™	RapidConfigure™	TinyPower™
FACT®	Motion-SPM™	SMART START™	TinyPWM™
FAST®	OPTOLOGIC®	SPM®	TinyWire™
FastvCore™	OPTOPLANAR®	STEALTH™	μSerDes™
FPS™	PDP-SPM™	SuperFET™	UHC®
FRFET®	Power220®	SuperSOT™-3	UniFET™
Global Power ResourceSM	Power247®	SuperSOT™-6	VCX™
Green FPS™	POWEREDGE®	SuperSOT™-8	

DISCLAIMER

FAIRCHILD SEMICONDUCTOR RESERVES THE RIGHT TO MAKE CHANGES WITHOUT FURTHER NOTICE TO ANY PRODUCTS HEREIN TO IMPROVE RELIABILITY, FUNCTION, OR DESIGN. FAIRCHILD DOES NOT ASSUME ANY LIABILITY ARISING OUT OF THE APPLICATION OR USE OF ANY PRODUCT OR CIRCUIT DESCRIBED HEREIN; NEITHER DOES IT CONVEY ANY LICENSE UNDER ITS PATENT RIGHTS, NOR THE RIGHTS OF OTHERS. THESE SPECIFICATIONS DO NOT EXPAND THE TERMS OF FAIRCHILD'S WORLDWIDE TERMS AND CONDITIONS, SPECIFICALLY THE WARRANTY THEREIN, WHICH COVERS THESE PRODUCTS.

LIFE SUPPORT POLICY

FAIRCHILD'S PRODUCTS ARE NOT AUTHORIZED FOR USE AS CRITICAL COMPONENTS IN LIFE SUPPORT DEVICES OR SYSTEMS WITHOUT THE EXPRESS WRITTEN APPROVAL OF FAIRCHILD SEMICONDUCTOR CORPORATION.

As used herein:

- Life support devices or systems are devices or systems which, (a) are intended for surgical implant into the body, or (b) support or sustain life, and (c) whose failure to perform when properly used in accordance with instructions for use provided in the labeling, can be reasonably expected to result in significant injury to the user.
- A critical component is any component of a life support device or system whose failure to perform can be reasonably expected to cause the failure of the life support device or system, or to affect its safety or effectiveness.

PRODUCT STATUS DEFINITIONS

Definition of Terms

Datasheet Identification	Product Status	Definition
Advance Information	Formative or In Design	This datasheet contains the design specifications for product development. Specifications may change in any manner without notice.
Preliminary	First Production	This datasheet contains preliminary data; supplementary data will be published at a later date. Fairchild Semiconductor reserves the right to make changes at any time without notice to improve design.
No Identification Needed	Full Production	This datasheet contains final specifications. Fairchild Semiconductor reserves the right to make changes at any time without notice to improve design.
Obsolete	Not In Production	This datasheet contains specifications on a product that has been discontinued by Fairchild semiconductor. The datasheet is printed for reference information only.

Rev. I28

Mouser Electronics

Authorized Distributor

Click to View Pricing, Inventory, Delivery & Lifecycle Information:

[ON Semiconductor:](#)

[MM74HC4040N](#) [MM74HC4040MX](#) [MM74HC4040N_Q](#)