

8D Corrective Action Report

Device: MV54164

PQA Number: 2005020050

Date: 7. January 2005

Author: Liam WH

Failure analysis is performed as a technical service to the users of microcircuits manufactured by Fairchild Semiconductor Corporation (Fairchild). Failure Analysis Reports or PQA Reports are considered proprietary to Fairchild and are furnished by Fairchild on the sole condition that the user agrees not to disclose any contents of the Failure Analysis Report to a third party. Information conveyed in these reports in no way alters Fairchild's product warranty policy and under no circumstances can these reports be used as an authorization to return product to Fairchild.

Customer Information:

Name: ABACUS (PROMAX) DENMARK
Location: ,DNK

<u>Contacts</u>	<u>Name</u>	<u>Phone</u>	<u>Fax</u>
-----------------	-------------	--------------	------------

Part Number:

Reference Documents:

<u>Reference Type</u>	<u>Reference Number</u>
-----------------------	-------------------------

Summary/Abstract:

Received sample due to outline dimension is out of specification.
After verification, this is because the data sheet is not updated per the changes.
Need product line to update data sheet to fix the actual outline dimension accordingly.

Team Members:

Tan, CH
Reinkensmeier, Stefan +49-8141-6102-108 CQE
Liam, WH 04-8502783 Primary contact for this file

Problem Description:

Customer Claim: The part is out of specification, too long. The maximum dimension is 25.27mm, but has some in 25.43mm.

Device Info: Package Leads Stampoff ROM Code
MV5X

Technology: Default
Process: Commercial
Division: Fairchild
Product Group: INTEGRATED CIRCUITS GROUP
Accounting Group: Standard Display

<u>Datecode</u>	<u>Die Run</u>	<u>Quantity</u>	<u>Top marking</u>
0440		1	440

Reported Fail Status: IQC
Reported Fail Temperature:
Reported Test Condition: visual

Containment Actions:

Action Item #1: Check current production line at subcon
Implementation date: 05 Jan 2005
Person responsible: Liam, WH
Comment: Sample 100pcs to measure outline dimension, all meet specification

Define Root Cause:

Findings During This Analysis:

<u>Top Marking</u>	<u>Serial Number</u>	<u>Description</u>
440		Layout
440		GOOD DEVICE

Process name: Initial Verification
 Person responsible: Liam, WH
 Step initiated date: 06 Jan 2005
 Step completion date: 06 Jan 2005

Measure the returned unit using caliper.

MV54164 Outline Dimension

Spec: 1.005"(max) - 25.53mm(max)- , data sheet- 1.000"(max)-25.4mm(max)

No	1		2		3	
1	1.001	25.43	1.001	25.43	1.001	25.43
2	1.001	25.43	1.001	25.43	1.001	25.43
3	1.001	25.43	1.001	25.43	1.001	25.43
4	1.000	25.40	1.000	25.40	1.000	25.40
5	1.001	25.43	1.001	25.43	1.001	25.43
6	1.000	25.40	1.000	25.40	1.000	25.40
7	1.000	25.40	1.000	25.40	1.000	25.40
8	1.000	25.40	1.000	25.40	1.000	25.40
9	1.001	25.43	1.001	25.43	1.002	25.45
10	1.000	25.40	1.000	25.40	1.000	25.40
11	1.000	25.40	1.000	25.40	1.000	25.40
12	1.000	25.40	1.000	25.40	1.000	25.40
13	1.000	25.40	1.000	25.40	1.000	25.40
14	1.000	25.40	1.000	25.40	1.000	25.40
15	1.000	25.40	0.999	25.37	1.000	25.40
16	1.001	25.43	1.001	25.43	1.001	25.43
17	1.001	25.43	1.001	25.43	1.001	25.43
18	1.000	25.40	1.000	25.40	1.001	25.43
19	1.000	25.40	1.000	25.40	1.001	25.43
20	1.000	25.40	1.000	25.40	1.000	25.40

We are always refer to Figure 2 to measure the dimension.
 From the result shown, all the reading meets the internal specification.

Process name: Failure Analysis 1
 Person responsible: Liam, WH
 Step initiated date: 06 Jan 2005
 Step completion date: 06 Jan 2005

We have found out that the data sheet from the web indicated the outline dimension with 1.00" max – with 25.27mm (Figure 1). We also found the 1.00" should indicate measurement of 25.40mm instead of 25.27mm (1.00" = 25.4mm)

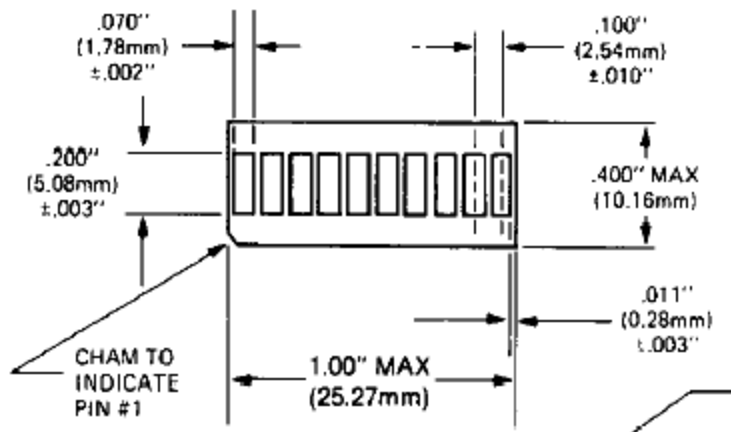

Figure 1

We refer back with the current used outline drawing (Figure 2), noticed that the outline dimension is 1.005max which is equivalent to 25.53mm. This specification has been revised to state the changes since February 1982. But somehow the data sheet of this part is not updated in the website to reflect the changes.

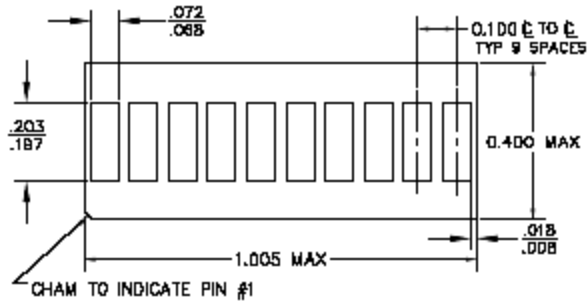

Figure 2

Measurement also being done in IQA and OQA. The detail data is shown below:-

INCOMING QA MEASURED DATA

PART NO: 302207_09
 VENDOR: JAR JUNG

DONE BY:(NAME) Miao yanming
 DATE: 12/27/04

Dimension No	Specification Requirement	Actual Readings of Samples(Raw Cap)								Disposition	Equipment
		# 1	# 2	# 3	# 4	# 5	# 6	# 7	# 8		
	1.000 max	0.990	0.990	0.990	1.000	0.990	0.990	1.000	1.000	ACC	Caliper
	Unit : "	1.000	1.000	0.990	1.000	1.000	1.000	0.995	1.000	ACC	Caliper
		0.990	0.995	1.000	1.000	1.000	0.990	1.000	0.995	ACC	Caliper
	25.40 max	25.15	25.15	25.15	25.40	25.15	25.15	25.40	25.40		
	Unit : mm	25.40	25.40	25.15	25.40	25.45	25.40	24.13	25.40		
		25.15	24.13	25.40	25.40	25.40	25.15	25.40	24.13		

OUTGOING QA MEASURED DATA

PART NO: MV59164

DONE BY:(NAME) Miao yanming
 DATE: 12/28/2004

Dimension No	Specification Requirement	Actual Readings of Samples(Finish products)								Disposition	Equipment
		# 1	# 2	# 3	# 4	# 5	# 6	# 7	# 8		
	1.005 max	1.0040	1.0020	1.0010	1.0025	1.0040	1.0020	1.0020	1.0010	ACC	Caliper
	Unit : "										
	25.53 max										
	Unit : mm	25.50	25.45	25.43	25.46	25.50	25.45	25.45	25.43		

The dimension of 1.000"max is for RAW CAP only. For the finished good, the dimension is 1.005"max. After encapsulation, the cap will have slight expansion. It is reasonable phenomenon.

From the data shown, all meet the specification.

Verify Corrective Actions:

Action Item #1: Update datasheet per the changes
 Verification date: 07 Jan 2005
 Person responsible: Liam, WH
 Should action be implemented?: Yes

Implement Corrective Actions:

Action Item #1: Update datasheet per the changes
Implementation date: 07 Jan 2005
Person responsible: Liam, WH
Has action been implemented?: Yes
Comment: To inform this changes to product line accordingly

Prevent Recurrence:

Action Item #1: Review data sheet
Responsible person: Product Line
Expected implementation date: 07 Jan 2004
Status: This is a continuous on going activity to review any mismatch of data sheet with internal document from subcon

Closure:

Disposition of units: Sample detained in factory.