

2 Output PCI Express* Buffer with CLKREQ# Function

ICS9DB102

Description

1-to-2 Zero-delay or fanout buffer for PCI Express. The **ICS9DB102** zero-delay buffer supports PCI Express clocking requirements. The **ICS9DB102** is driven by a differential SRC output pair from an ICS CK409/CK410-compliant main clock generator such as the ICS952601 or ICS954101. It attenuates jitter on the input clock and has a selectable PLL Band Width to maximize performance in systems with or without Spread-Spectrum clocking.

Output Features

- 2 - 0.7V current mode differential output pairs (HSCL)

Features/Benefits

- CLKREQ# pin for outputs 1 and 4/output enable for Express Card applications
- PLL or bypass mode/PLL can dejitter incoming clock
- Selectable PLL bandwidth/minimizes jitter peaking in downstream PLL's
- Spread Spectrum Compatible/tracks spreading input clock for low EMI
- SMBus Interface/unused outputs can be disabled

Key Specifications

- Cycle-to-cycle jitter < 35ps
- Output-to-output skew < 25ps

Functional Block Diagram

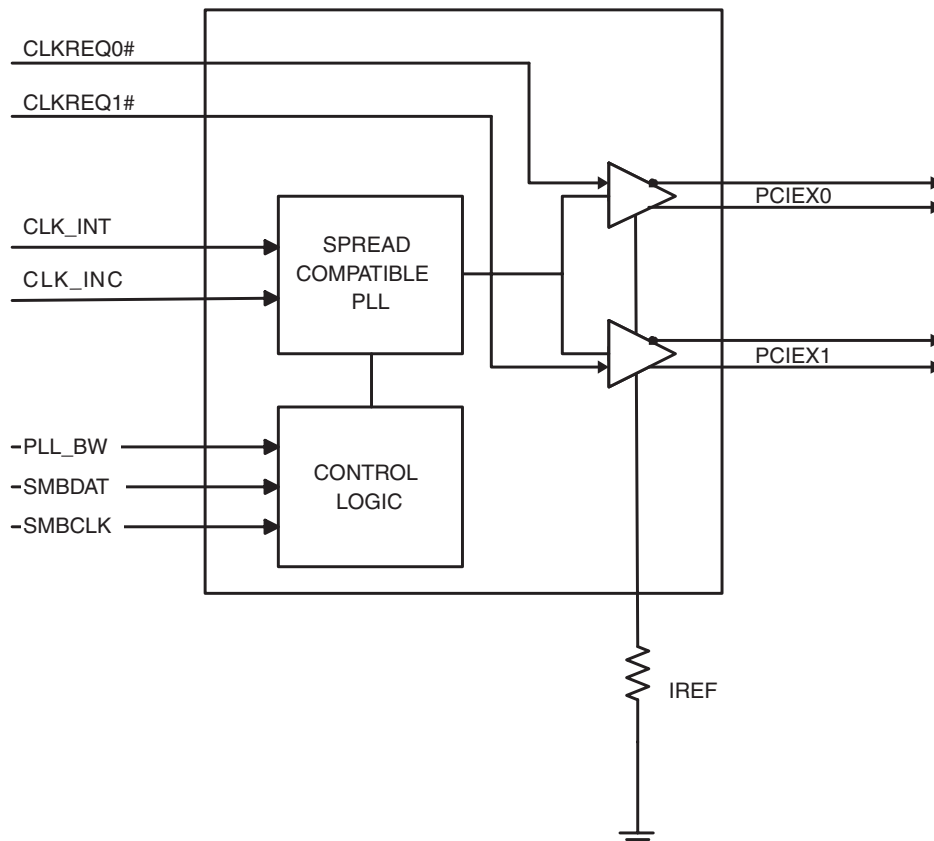

Pin Configuration

PLL_BW	1	ICS9DB102	20	VDDA
CLK_INT	2		19	GNDA
CLK_INC	3		18	IREF
**CLKREQ0#	4		17	**CLKREQ1#
VDD	5		16	VDD
GND	6		15	GND
PCIEXT0	7		14	PCIEXT1
PCIEXC0	8		13	PCIEXC1
VDD	9		12	VDD
SMBDAT	10		11	SMBCLK

Note: Pins preceded by '**' have internal 120K ohm pull down resistors

20-pin SSOP & TSSOP

Power Groups

Pin Number		Description
VDD	GND	
5,9,12,16	6,15	PCI Express Outputs
9	6	SMBUS
20	19	IREF
20	19	Analog VDD & GND for PLL core

Pin Description

PIN #	PIN NAME	PIN TYPE	DESCRIPTION
1	PLL_BW	INPUT	3.3V input for selecting PLL Band Width 0 = low, 1 = high
2	CLK_INT	INPUT	"True" reference clock input.
3	CLK_INC	INPUT	"Complementary" reference clock input.
4	**CLKREQ0#	INPUT	Output enable for SRC/PCI Express output pair '0' 0 = enabled, 1 = tri-stated
5	VDD	POWER	Power supply, nominal 3.3V
6	GND	POWER	Ground pin.
7	PCIEXT0	OUTPUT	True clock of differential PCI_Express pair.
8	PCIEXC0	OUTPUT	Complement clock of differential PCI_Express pair.
9	VDD	POWER	Power supply, nominal 3.3V
10	SMBDAT	I/O	Data pin of SMBUS circuitry, 5V tolerant
11	SMBCLK	INPUT	Clock pin of SMBUS circuitry, 5V tolerant
12	VDD	POWER	Power supply, nominal 3.3V
13	PCIEXC1	OUTPUT	Complement clock of differential PCI_Express pair.
14	PCIEXT1	OUTPUT	True clock of differential PCI_Express pair.
15	GND	POWER	Ground pin.
16	VDD	POWER	Power supply, nominal 3.3V
17	**CLKREQ1#	INPUT	Output enable for SRC/PCI Express output pair '1' 0 = enabled, 1 = tri-stated
18	IREF	OUTPUT	This pin establishes the reference current for the differential current-mode output pairs. This pin requires a fixed precision resistor tied to ground in order to establish the appropriate current. 475 ohms is the standard value.
19	GNDA	POWER	Ground pin for the PLL core.
20	VDDA	POWER	3.3V power for the PLL core.

Note:

Pins preceded by '**' have internal 120K ohm pull down resistors

Absolute Max

Symbol	Parameter	Min	Max	Units
VDDA	3.3V Core Supply Voltage		$V_{DD} + 0.5V$	V
VDD	3.3V Output Supply Voltage	GND - 0.5	$V_{DD} + 0.5V$	V
Ts	Storage Temperature	-65	150	°C
Tambient	Ambient Operating Temp	0	70	°C
Tcase	Case Temperature		115	°C
ESD prot	Input ESD protection human body model	2000		V

Electrical Characteristics - Input/Supply/Common Output Parameters

T_A = 0 - 70°C; Supply Voltage V_{DD} = 3.3 V +/-5%

PARAMETER	SYMBOL	CONDITIONS	MIN	TYP	MAX	UNITS	NOTES
Input High Voltage	V _{IH}	3.3 V +/-5%	2		V _{DD} + 0.3	V	1
Input Low Voltage	V _{IL}	3.3 V +/-5%	V _{SS} - 0.3		0.8	V	1
Input High Current	I _{IH}	V _{IN} = V _{DD}	-5		5	uA	1
Input Low Current	I _{IL1}	V _{IN} = 0 V; Inputs with no pull-up resistors	-5			uA	1
	I _{IL2}	V _{IN} = 0 V; Inputs with pull-up resistors	-200			uA	1
Operating Supply Current	I _{DD3.3OP}	Full Active, C _L = Full load;		75	100	mA	1
		all differential pairs tri-stated		27	50	mA	1
Input Frequency ³	F _i	V _{DD} = 3.3 V	99	100	101	MHz	1
Pin Inductance ¹	L _{pin}				7	nH	1
Input Capacitance ¹	C _{IN}	Logic Inputs			5	pF	1
	C _{OUT}	Output pin capacitance			4.5	pF	1
Clk Stabilization ^{1,2}	T _{STAB}	From V _{DD} Power-Up to 1st clock			1.8	ms	1
Modulation Frequency		Triangular Modulation	30		33	kHz	1
Spread Spectrum Modulation Frequency	f _{MOD}	Lexmark Modulation	25		45	KHz	1
PLL Bandwidth	BW	PLL Bandwidth when PLL_BW=0		400		KHz	1
		PLL Bandwidth when PLL_BW=1		1.2		MHz	1
SMBus Voltage	V _{DD}		2.7		5.5	V	1
Low-level Output Voltage	V _{OL} SMBUS	@ I _{PULLUP}			0.4	V	1
Current sinking at V _{OL} = 0.4 V	I _{PULLUP}	SMBus SDATA pin	4			mA	1
SCLK/SDATA Clock/Data Rise Time	T _{RI2C}	(Max V _{IL} - 0.15) to (Min V _{IH} + 0.15)			1000	ns	1
SCLK/SDATA Clock/Data Fall Time	T _{FI2C}	(Min V _{IH} + 0.15) to (Max V _{IL} - 0.15)			300	ns	1

¹Guaranteed by design and characterization, not 100% tested in production.

Electrical Characteristics - PCIeX 0.7V Current Mode Differential Pair

$T_A = 0 - 70^\circ\text{C}$; $V_{DD} = 3.3\text{ V} \pm 5\%$; $C_L = 2\text{pF}$, $R_S = 33.2\Omega$, $R_P = 49.9\Omega$, $I_{REF} = 475\Omega$

PARAMETER	SYMBOL	CONDITIONS	MIN	TYP	MAX	UNITS	NOTES
Current Source Output Impedance	Zo	$V_O = V_x$	3000			Ω	1
Voltage High	VHigh	Statistical measurement on single ended signal using oscilloscope	660		850	mV	1,3
Voltage Low	VLow		-150		150		1,3
Max Voltage	Vovs	Measurement on single ended signal using absolute value.			1150	mV	1,3
Min Voltage	Vuds		-300				1,3
Crossing Voltage (abs)	Vcross(abs)		250	350	550	mV	1,3
Crossing Voltage (var)	d-Vcross	Variation of crossing over all edges		12	140	mV	1,3
Long Accuracy	ppm	see Tperiod min-max values			0	ppm	1,2
Average period	Tperiod	100.00MHz nominal	9.9970		10.0030	ns	2
		100.00MHz spread	9.9970		10.0533	ns	2
Absolute min period	Tabsmin	100.00MHz nominal/spread	9.8720			ns	1,2
Rise Time	t _r	$V_{OL} = 0.175\text{V}$, $V_{OH} = 0.525\text{V}$	175		700	ps	1
Fall Time	t _f	$V_{OH} = 0.525\text{V}$ $V_{OL} = 0.175\text{V}$	175		700	ps	1
Rise Time Variation	d-t _r			30	125	ps	1
Fall Time Variation	d-t _f			30	125	ps	1
Input to Output Delay	t _{pd}	PLL Mode.	135		185	ps	1
	t _{pdbyb}	Bypass mode	3.2		3.7	ns	1
Duty Cycle	d _{t3}	Measurement from differential waveform	45		55	%	1
Output-to-Output Skew	t _{sk3}	$V_T = 50\%$			25	ps	1
Jitter, Cycle to cycle	t _{jyc-cyc}	PLL mode. Measurement from differential waveform			35	ps	1
	t _{jyc-cycbyp}	Additive Jitter in Bypass Mode			30	ps	1

¹Guaranteed by design, not 100% tested in production.

²All Long Term Accuracy and Clock Period specifications are guaranteed with the assumption that the input clock complies with CK409/CK410 accuracy requirements

³ $I_{REF} = V_{DD}/(3 \times R_R)$. For $R_R = 475\Omega$ (1%), $I_{REF} = 2.32\text{mA}$. $I_{OH} = 6 \times I_{REF}$ and $V_{OH} = 0.7\text{V}$ @ $Z_O = 50\Omega$.

General SMBus serial interface information for the ICS9DB102

How to Write:

- Controller (host) sends a start bit.
- Controller (host) sends the write address $D4_{(H)}$
- ICS clock will **acknowledge**
- Controller (host) sends the beginning byte location = N
- ICS clock will **acknowledge**
- Controller (host) sends the data byte count = X
- ICS clock will **acknowledge**
- Controller (host) starts sending **Byte N through Byte N + X - 1**
(see Note 2)
- ICS clock will **acknowledge** each byte **one at a time**
- Controller (host) sends a Stop bit

How to Read:

- Controller (host) will send start bit.
- Controller (host) sends the write address $D4_{(H)}$
- ICS clock will **acknowledge**
- Controller (host) sends the beginning byte location = N
- ICS clock will **acknowledge**
- Controller (host) will send a separate start bit.
- Controller (host) sends the read address $D5_{(H)}$
- ICS clock will **acknowledge**
- ICS clock will send the data byte count = X
- ICS clock sends **Byte N + X - 1**
- ICS clock sends **Byte 0 through byte X (if $X_{(H)}$ was written to byte 8).**
- Controller (host) will need to acknowledge each byte
- Controller (host) will send a not acknowledge bit
- Controller (host) will send a stop bit

Index Block Write Operation		
Controller (Host)		ICS (Slave/Receiver)
T	starT bit	
Slave Address $D4_{(H)}$		
WR	WRite	
		ACK
Beginning Byte = N		
		ACK
Data Byte Count = X		
		ACK
Beginning Byte N	X Byte	
○		ACK
○		○
○		○
Byte N + X - 1		○
		ACK
P	stoP bit	

Index Block Read Operation		
Controller (Host)		ICS (Slave/Receiver)
T	starT bit	
Slave Address $D4_{(H)}$		
WR	WRite	
		ACK
Beginning Byte = N		
		ACK
RT	Repeat starT	
Slave Address $D5_{(H)}$		
RD	ReaD	
		ACK
		Data Byte Count = X
ACK		
		Beginning Byte N
ACK		
○		X Byte
○		
○		
○		
		Byte N + X - 1
N	Not acknowledge	
P	stoP bit	

ICS9DB102
2 Output PCI Express* Buffer with CLKREQ# Function

SMBus Table: Device Control Register, READ/WRITE ADDRESS (D4/D5)

Byte 0	Pin #	Name	Control Function	Type	0	1	PWD
Bit 7	-	SW_EN	Enables SMBus Control	RW	Functions controlled by SMBus registers	Functions controlled by device pins	1
Bit 6	-	RESERVED		RW	-	-	X
Bit 5	-	RESERVED		RW	-	-	X
Bit 4	-	RESERVED		RW	-	-	X
Bit 3	-	RESERVED		RW	-	-	X
Bit 2	-	RESERVED		RW	-	-	X
Bit 1	-	PLL BW #adjust	Selects PLL Bandwidth	RW	Low BW	High BW	1
Bit 0	-	PLL Enable	Bypasses PLL for board test	RW	PLL bypassed (fan out mode)	PLL enabled (ZDB mode)	1

SMBus Table: Output Enable Register

Byte 1	Pin #	Name	Control Function	Type	0	1	PWD
Bit 7	-	RESERVED		RW	-	-	X
Bit 6	-	RESERVED		RW	-	-	X
Bit 5	-	RESERVED		RW	-	-	X
Bit 4	-	RESERVED		RW	-	-	X
Bit 3	-	RESERVED		RW	-	-	X
Bit 2	-	RESERVED		RW	-	-	X
Bit 1	-	RESERVED		RW	-	-	X
Bit 0	-	RESERVED		RW	-	-	X

SMBus Table: Function Select Register

Byte 2	Pin #	Name	Control Function	Type	0	1	PWD
Bit 7	-	RESERVED		RW	-	-	X
Bit 6	-	RESERVED		RW	-	-	X
Bit 5	-	RESERVED		RW	-	-	X
Bit 4	-	RESERVED		RW	-	-	X
Bit 3	-	RESERVED		RW	-	-	X
Bit 2	-	RESERVED		RW	-	-	X
Bit 1	-	RESERVED		RW	-	-	X
Bit 0	-	RESERVED		RW	-	-	X

SMBus Table: Vendor & Revision ID Register

Byte 3	Pin #	Name	Control Function	Type	0	1	PWD
Bit 7	-	RID3	REVISION ID	R	-	-	0
Bit 6	-	RID2		R	-	-	0
Bit 5	-	RID1		R	-	-	0
Bit 4	-	RID0		R	-	-	0
Bit 3	-	VID3	VENDOR ID	R	-	-	0
Bit 2	-	VID2		R	-	-	0
Bit 1	-	VID1		R	-	-	0
Bit 0	-	VID0		R	-	-	1

SMBus Table: DEVICE ID

Byte 4	Pin #	Name	Control Function	Type	0	1	PWD
Bit 7	-	Device ID = 06 Hex		R	-	-	0
Bit 6	-			R	-	-	0
Bit 5	-			R	-	-	0
Bit 4	-			R	-	-	0
Bit 3	-			R	-	-	0
Bit 2	-			R	-	-	1
Bit 1	-			R	-	-	1
Bit 0	-			R	-	-	0

SMBus Table: Byte Count Register

Byte 5	Pin #	Name	Control Function	Type	0	1	PWD
Bit 7	-	BC7	Writing to this register will configure how many bytes will be read back, default is 06 = 6 bytes.	RW	-	-	0
Bit 6	-	BC6		RW	-	-	0
Bit 5	-	BC5		RW	-	-	0
Bit 4	-	BC4		RW	-	-	0
Bit 3	-	BC3		RW	-	-	0
Bit 2	-	BC2		RW	-	-	1
Bit 1	-	BC1		RW	-	-	1
Bit 0	-	BC0		RW	-	-	0

ICS9DB102
2 Output PCI Express* Buffer with CLKREQ# Function

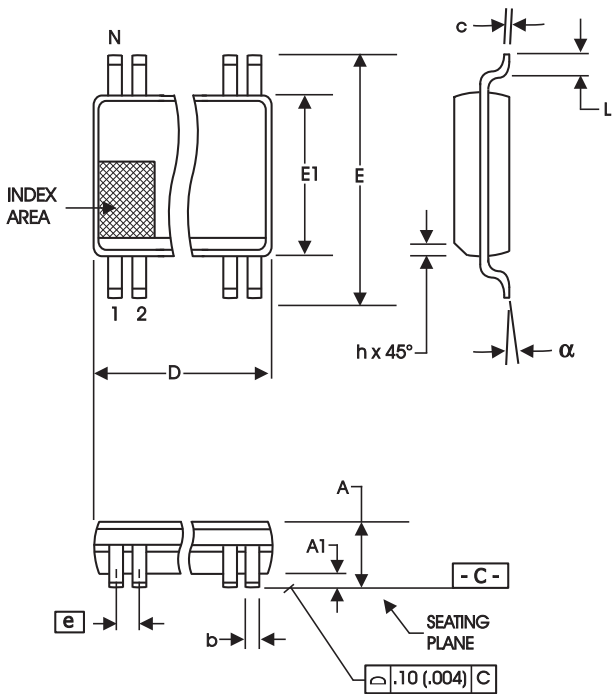

20-Lead, 150 mil SSOP (QSOP)

SYMBOL	In Millimeters		In Inches	
	COMMON DIMENSIONS	COMMON DIMENSIONS	COMMON DIMENSIONS	COMMON DIMENSIONS
	MIN	MAX	MIN	MAX
A	1.35	1.75	.053	.069
A1	0.10	0.25	.004	.010
A2	--	1.50	--	.059
b	0.20	0.30	.008	.012
c	0.18	0.25	.007	.010
D	SEE VARIATIONS		SEE VARIATIONS	
E	5.80	6.20	.228	.244
E1	3.80	4.00	.150	.157
e	0.635 BASIC		0.025 BASIC	
L	0.40	1.27	.016	.050
N	SEE VARIATIONS		SEE VARIATIONS	
a	0°	8°	0°	8°
ZD	SEE VARIATIONS		SEE VARIATIONS	

Ordering Information

ICS9DB102yFLFT

Example:

ICS XXXX y F LFT

- Designation for tape and reel packaging
- Lead Free, RoHS Compliant (Optional)
- Package Type
F = SSOP
- Revision Designator (will not correlate with datasheet revision)
- Device Type (consists of 3 to 7 digit numbers)
- Prefix
ICS, AV = Standard Device

ICS9DB102
2 Output PCI Express* Buffer with CLKREQ# Function

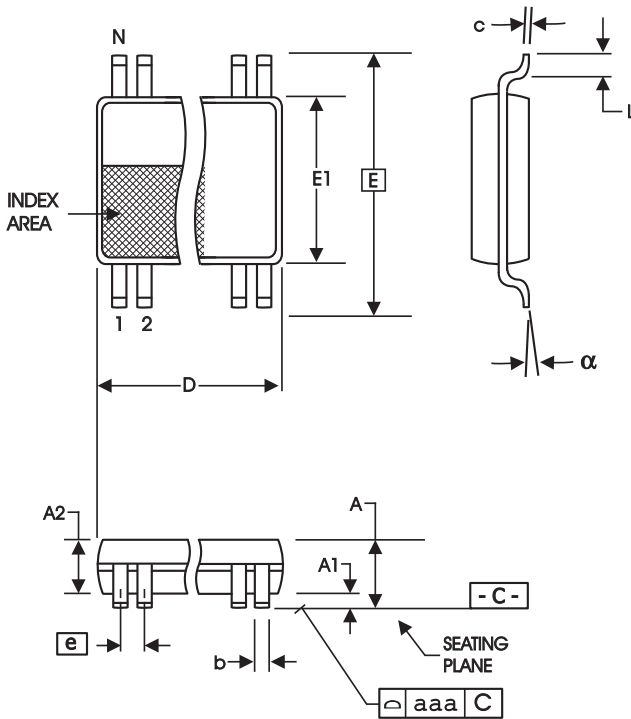

20-Lead, 4.40 mm. Body, 0.65 mm. Pitch TSSOP
(173 mil) (25.6 mil)

SYMBOL	In Millimeters		In Inches	
	COMMON DIMENSIONS		COMMON DIMENSIONS	
	MIN	MAX	MIN	MAX
A	--	1.20	--	.047
A1	0.05	0.15	.002	.006
A2	0.80	1.05	.032	.041
b	0.19	0.30	.007	.012
c	0.09	0.20	.0035	.008
D	SEE VARIATIONS		SEE VARIATIONS	
E	6.40 BASIC		0.252 BASIC	
E1	4.30	4.50	.169	.177
e	0.65 BASIC		0.0256 BASIC	
L	0.45	0.75	.018	.030
N	SEE VARIATIONS		SEE VARIATIONS	
a	0°	8°	0°	8°
aaa	--	0.10	--	.004

VARIATIONS

N	D mm.		D (inch)	
	MIN	MAX	MIN	MAX
20	6.40	6.60	.252	.260

Reference Doc.: JEDEC Publication 95, MO-153

10-0035

Ordering Information

ICS9DB102yGLFT

Example:

ICS XXXX yG LFT

Designation for tape and reel packaging
 Lead Free, RoHS Compliant (Optional)

Package Type
 G = TSSOP

Revision Designator (will not correlate with datasheet revision)

Device Type (consists of 3 to 7 digit numbers)

Prefix

ICS, AV = Standard Device

Innovate with IDT and accelerate your future networks. Contact:

www.IDT.com

For Sales

800-345-7015
408-284-8200
Fax: 408-284-2775

For Tech Support

408-284-6578
pcclockhelp@idt.com

Corporate Headquarters

Integrated Device Technology, Inc.
6024 Silver Creek Valley Road
San Jose, CA 95138
United States
800 345 7015
+408 284 8200 (outside U.S.)

Asia Pacific and Japan

Integrated Device Technology
Singapore (1997) Pte. Ltd.
Reg. No. 199707558G
435 Orchard Road
#20-03 Wisma Atria
Singapore 238877
+65 6 887 5505

Europe

IDT Europe, Limited
Prime House
Barnett Wood Lane
Leatherhead, Surrey
United Kingdom KT22 7DE
+44 1372 363 339



www.IDT.com