

Surface Mount Multilayer Ceramic Capacitors

Commercial Grade

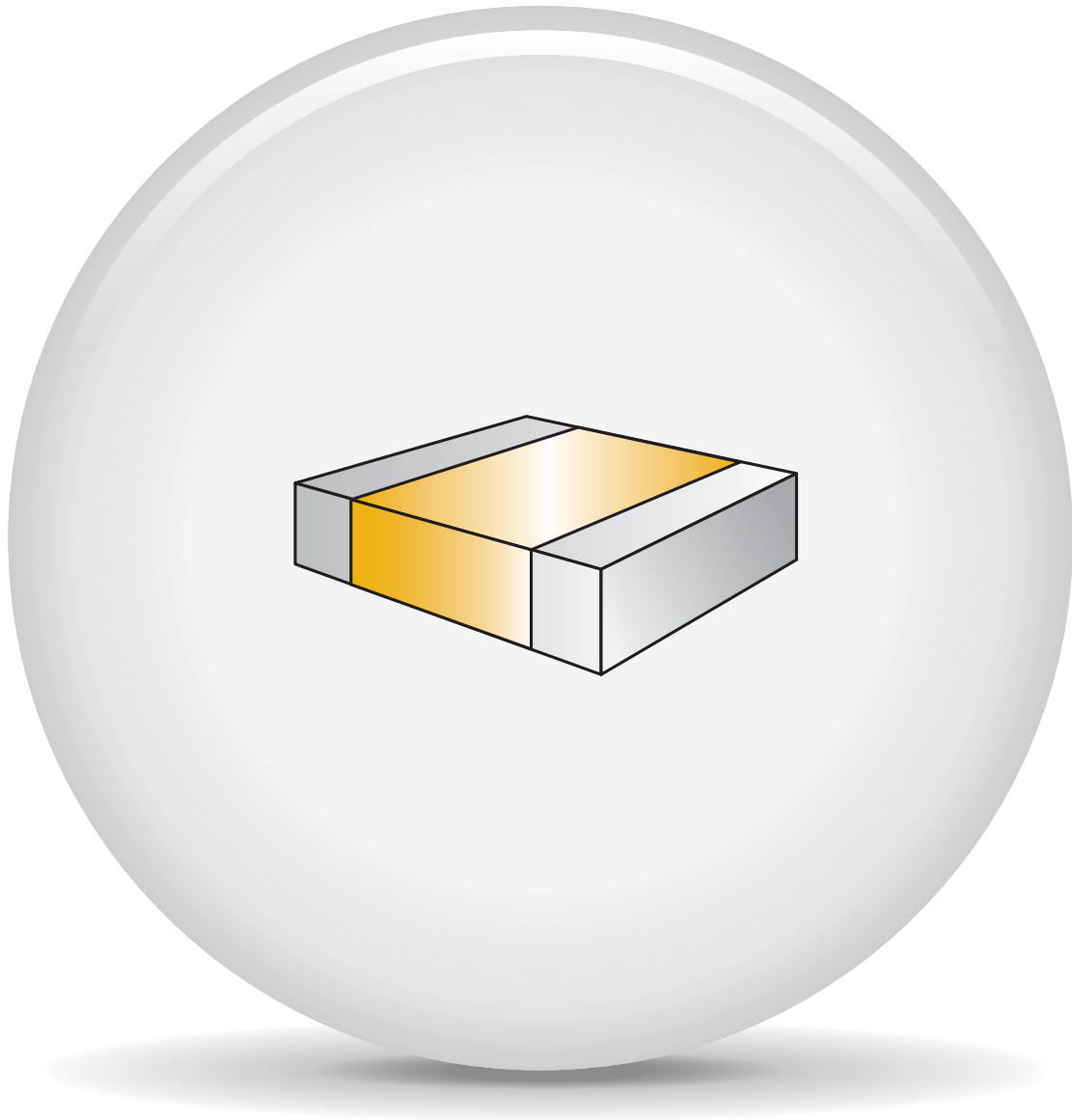

One world. One KEMET.

The Capacitance Company
KEMET
CHARGED.®

Table of Contents	Page
Why Choose KEMET	4
Standard Products	
COG Dielectric, 10VDC-200VDC	10
X7R Dielectric, 6.3VDC-250VDC	16
X5R Dielectric, 4VDC-50VDC	22
Z5U Dielectric, 50VDC-100VDC	26
Y5V Dielectric, 6.3VDC-50VDC	30
Capacitor, Array, COG Dielectric, 10VDC to 200VDC	34
Capacitor, Array, X7R Dielectric, 10VDC to 200VDC	40
Commercial Off-the-Shelf (COTS) for Higher Reliability Applications, COG Dielectric, 10VDC-200VDC	46
Commercial Off-the-Shelf (COTS) for Higher Reliability Applications, X7R Dielectric, 6.3VDC-200VDC	52
Telecom "Tip and Ring," X7R Dielectric, 250VDC	58
Flex Mitigation Solutions	
Open Mode Design, X7R Dielectric, 16VDC-200VDC	62
Floating Electrode Design (FE-CAP), X7R Dielectric, 6.3VDC-250VDC	70
Flexible Termination System (FT-CAP), X7R Dielectric, 6.3VDC-250VDC	75
High Voltage with Flexible Termination System (HV FT-CAP), X7R Dielectric, 500VDC-3000VDC	81
Floating Electrode Design with Flexible Termination System (FF-CAP), X7R Dielectric, 6.3VDC-250VDC	86
KPS Series, X7R Dielectric, 10VDC-250VDC	91
SnPb End Metallization	
Commercial "L" Series, SnPb Termination, COG Dielectric, 10VDC-200VDC	101
Commercial "L" Series, SnPb Termination, X7R Dielectric, 6.3VDC-250VDC	107
Commercial Off-the-Shelf (COTS) for Higher Reliability Applications, COG Dielectric, 10VDC-200VDC	112
Commercial Off-the-Shelf (COTS) for Higher Reliability Applications, X7R Dielectric, 6.3VDC-200VDC	118
High Temperature 150°C, Ultra Stable X8R Dielectric, 25VDC-100VDC	124
High Temperature 150°C, X8L Dielectric, 10VDC-50VDC	129
Telecom "Tip and Ring," X7R Dielectric, 250VDC	137
Open Mode Design, X7R Dielectric, 16VDC-200VDC	141
Floating Electrode Design (FE-CAP), X7R Dielectric, 6.3VDC-250VDC	149
Flexible Termination System (FT-CAP), X7R Dielectric, 6.3VDC-250VDC	154
Floating Electrode Design with Flexible Termination System (FF-CAP), X7R Dielectric, 6.3VDC-250VDC	160
Bulk Capacitance Solutions (Stacked Capacitors)	
KPS Series, X7R Dielectric, 10VDC-250VDC	165
KEMET Power Solutions (KPS) MIL Series, 50VDC-500VDC	175
High Temperature	
High Temperature 150°C, Ultra Stable X8R Dielectric, 25VDC-100VDC	198
High Temperature 150°C, X8L Dielectric, 10VDC-50VDC	203
High Temperature 200°C, COG Dielectric, 10VDC-200VDC	211

High Voltage

High Voltage C0G Dielectric, 500VDC-3000VDC.....	221
High Voltage X7R Dielectric, 500VDC-3000VDC	227
High Voltage with Flexible Termination System (HV FT-CAP), X7R Dielectric, 500VDC-3000VDC.....	233
KPS HV, Large Case, SM Series, C0G Dielectric, 500VDC-10KVDC (Industrial Grade)	238
KPS HV, Large Case, SM Series, X7R Dielectric, 500VDC-10KVDC (Industrial Grade).....	248
Chip Thickness/Packaging Quantities	259
Chip Capacitor Land Pattern Design Recommendations.....	260
Performance & Reliability.....	261
Packaging Information.....	262
Marking Information.....	268
KEMET Corporation Sales Offices	269
Other KEMET Resources.....	270

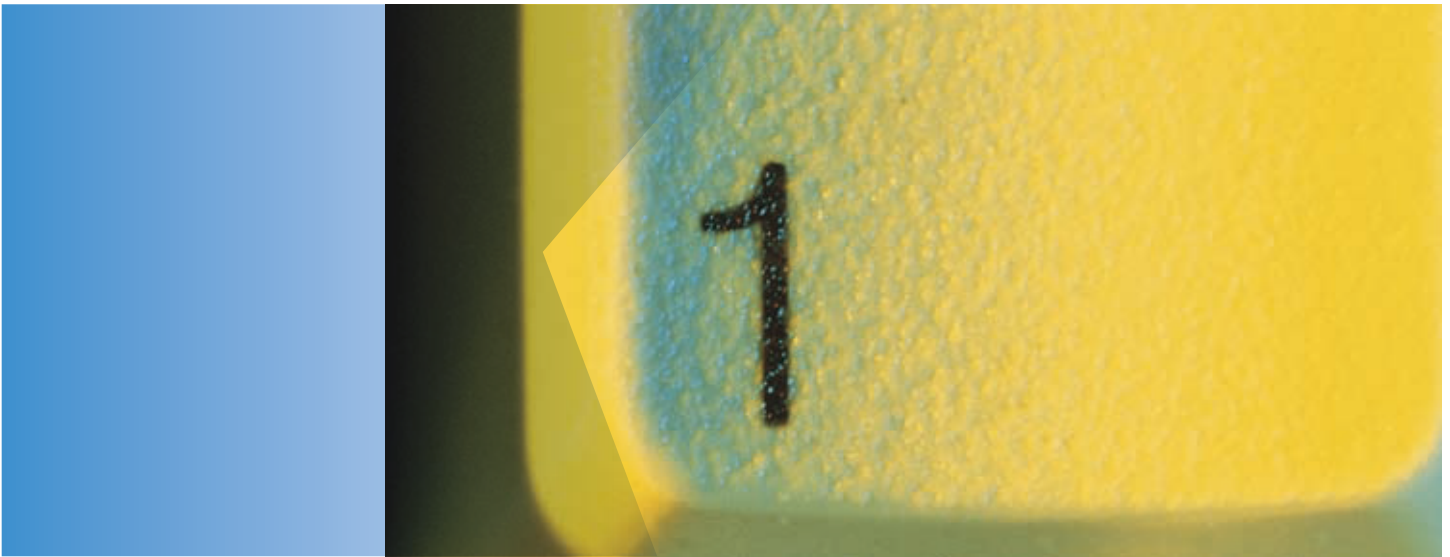

One world. One source. One KEMET.

No bouncing from supplier to supplier to find what you need. No multiple web sites and phone calls to get answers.

When you partner with KEMET, our entire global organization seamlessly provides you with the coordinated action and service you need. We're your single, integrated source for capacitance solutions worldwide, offering 95% of possible dielectric solutions, to cover practically any application. With new, innovative products year after year after year. Global availability. Full design collaboration, with fast custom design and prototyping to give your new products a competitive edge. Plus consistent quality, reliability and on-time delivery.

All from one company that's easy to work with and totally dedicated to your success. For anything to do with capacitance, call *The Capacitance Company* – KEMET.



Looking for a hassle-free source for 95% of possible dielectric solutions?

KEMET is the place for one-stop dielectric shopping. We offer our customers the broadest selection of capacitor technologies in the industry, including tantalum, ceramic, aluminum, electrolytic, film and paper.

But the range of products is only the beginning. You simply won't find an electronic components manufacturer more determined to find new technological solutions to customer problems, or more committed to product quality and on-time delivery – in every case, lowering your total cost of ownership as much as we possibly can. It's how we've helped customers succeed for more than 90 years. And it's how we're helping them succeed today.



We're everywhere you need us to be.

AMERICA

Canada
Mexico
USA

EMEA

Bulgaria
Finland
France
Germany
Italy
Portugal
Sweden
Switzerland
United Kingdom

ASIA-PACIFIC

China
Hong Kong
India
Indonesia
Japan
Malaysia
Singapore
Taiwan

The next time you board an airplane, boot up your computer or read about a breakthrough medical device, a piece of our technology is likely involved. KEMET customers include nearly all of the world's major electronics original equipment manufacturers, manufacturing services companies and electronics distributors. High Reliability versions of our capacitors are even in outer space, part of every important military and aerospace effort of the past 60 years, from the first Telstar satellite and Apollo 11 to the Patriot missile, International Space Station and Mars Pathfinder.

Our sales offices can't be quite as ubiquitous as our products, but we do pride ourselves on being where you need us. This map shows you our sales offices around the world.

As you can see, we're not only easy to work with, we're easy to find. And we're more than ready to be your single source capacitance solutions supplier.

One world. One source. One KEMET.

One WORLD One Brand One Strategy One Focus One Team One KEMET



Why The Capacitance Company is also the “Easy-To-Buy-From” company.

When you choose KEMET, you’ll enjoy a level of responsiveness you just won’t get from any other component manufacturer. You simply won’t find an electronic components manufacturer more passionate about customer service. Our innovative service offerings and superior localized support are known throughout the industry, powered by our global, customer-focused sales organization and worldwide logistics capabilities. We’re 100% committed to serving any customer, anywhere, and meeting customer needs when they need to be met.

Whether you need rush samples, technical assistance, in-person consultations or accelerated custom design, design collaboration and prototype services, we have a solution. If it’s anything to do with capacitance, we can help – and help fast.



Working to make a better world.

At KEMET, we're proud to work with customers to develop products that truly make the world a better, safer, more connected place to live – from hand-held devices to automotive systems to the greenest energy technology.

As a company, KEMET is dedicated to economically, environmentally and socially sustainable development. We've adopted the Electronic Industry Code of Conduct (EICC), addressing all aspects of corporate responsibility. All of our commercial-grade products are available in RoHS-compliant versions with Pb-free terminations. Our manufacturing facilities have won numerous environmental excellence awards and recognitions. And our supply chain is certified to be sourced from areas that are neither environmentally protected nor under conflict.

After all, we believe that doing the right thing is in everyone's interest.



Which capacitor is right for you?

As The Capacitance Company, we make over 95% of possible dielectric solutions – the broadest selection of capacitor technologies in the industry. By offering a wide variety of dielectrics, dimensions, voltages, temperature characteristics and terminations, KEMET capacitors satisfy an expansive range of customer requirements and applications.

In fact, if the capacitor you need hasn't been invented, it's only because you haven't asked. We can quickly develop custom products and carry out early-stage manufacturing through our accelerated collaboration services. Available through our global innovation and manufacturing centers around the world, accelerated collaboration brings together the necessary people, equipment and facilities together to get the job done, on time and in budget.

Of course, when you're under pressure to design smaller and smaller products with greater and greater functionality, there's no time for the traditional back-and-forth with your suppliers. With KEMET, you get direct contact to the engineers and other professionals who can help you successfully solve your design problems, and in record time. We deal personally with customers to ascertain the new part types needed for their next-generation products. In many cases, we can go from start to samples in only four months.

We've helped some of the world's most prominent electronics companies slash time to market and gain significant windows of competitive advantage. We can do the same for you, too.

Surface Mount Multilayer Ceramic Chip Capacitors (SMD MLCCs) C0G Dielectric, 10VDC-200VDC (Commercial Grade)

Overview

KEMET's C0G dielectric features a 125°C maximum operating temperature and is considered "stable." The Electronics Components, Assemblies & Materials Association (EIA) characterizes C0G dielectric as a Class I material. Components of this classification are temperature compensating and are suited for resonant circuit applications or those where Q and stability of capacitance characteristics are required. C0G exhibits no change in capacitance with respect to time and voltage and boasts a negligible change in capacitance with reference to ambient

temperature. Capacitance change is limited to $\pm 30\text{ppm}/^\circ\text{C}$ from -55°C to $+125^\circ\text{C}$.

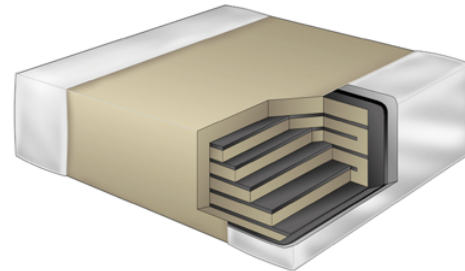

Benefits

- -55°C to $+125^\circ\text{C}$ operating temperature range
- RoHS compliant
- EIA 0201, 0402, 0603, 0805, 1206, 1210, 1808, 1812, 1825, 2220 and 2225 case sizes
- DC voltage ratings of 10V, 16V, 25V, 50V, 100V and 200V
- Capacitance offerings ranging from 0.5pF up to 0.47 μF
- Available capacitance tolerances of $\pm 0.25\text{pF}$, $\pm 0.5\text{pF}$, $\pm 1\%$, $\pm 2\%$, $\pm 5\%$, $\pm 10\%$ and $\pm 20\%$
- No piezoelectric noise
- Extremely low ESR and ESL
- High thermal stability
- High ripple current capability
- Preferred capacitance solution at line frequencies and into the MHz range
- No capacitance change with respect to applied rated DC voltage

- Negligible capacitance change with respect to temperature from -55°C to $+125^\circ\text{C}$
- No capacitance decay with time
- Non-polar device, minimizing installation concerns
- 100% pure matte tin-plated termination finish allowing for excellent solderability
- SnPb plated termination finish option available upon request (5% min)

Applications

Typical applications include critical timing, tuning, circuits requiring low loss, circuits with pulse, high current, decoupling, bypass, filtering, transient voltage suppression, blocking and energy storage.

Ordering Information

C	1206	C	104	J	3	G	A	C	TU
Ceramic	Case Size (L" x W")	Specification/ Series	Capacitance Code (pF)	Capacitance Tolerance ¹	Voltage	Dielectric	Failure Rate/ Design	Termination Finish ²	Packaging/Grade (C-Spec) ³
	0201 0402 0603 0805 1206 1210 1808 1812 1825 2220 2225	C = Standard	2 Sig. Digits + Number of Zeros Use 9 for 1.0 - 9.9pF Use 8 for 0.5 - .99pF ex. 2.2pF = 229 ex. 0.5pF = 508	C = $\pm 0.25\text{pF}$ D = $\pm 0.5\text{pF}$ F = $\pm 1\%$ G = $\pm 2\%$ J = $\pm 5\%$ K = $\pm 10\%$ M = $\pm 20\%$	8 = 10V 4 = 16V 3 = 25V 5 = 50V 1 = 100V 2 = 200V	G = C0G	A = N/A	C = 100% Matte Sn	Blank = Bulk TU = 7" Reel Unmarked

¹ Additional capacitance tolerance offerings may be available. Contact KEMET for details.

² Additional termination finish options may be available. Contact KEMET for details.

³ Additional reeling or packaging options may be available. Contact KEMET for details.

Dimensions – Millimeters (Inches)

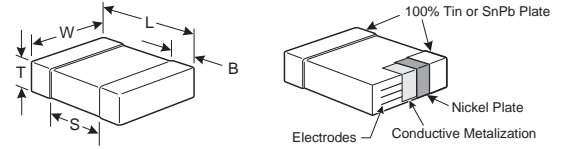

EIA Size Code	Metric Size Code	L Length	W Width	T Thickness	B Bandwidth	S Separation Min.	Mounting Technique
0201	0603	0.60 (.024) ± 0.03 (.001)	0.30 (.012) ± 0.03 (.001)	See Table 2 for Thickness	0.15 (.006) ± 0.05 (.002)	N/A	Solder Reflow Only
0402	1005	1.00 (.040) ± 0.05 (.002)	0.50 (.020) ± 0.05 (.002)		0.30 (.012) ± 0.10 (.004)	0.30 (.012)	
0603	1608	1.60 (.063) ± 0.15 (.006)	0.80 (.032) ± 0.15 (.006)		0.35 (.014) ± 0.15 (.006)	0.70 (.028)	Solder Wave or Solder Reflow
0805	2012	2.00 (.079) ± 0.20 (.008)	1.25 (.049) ± 0.20 (.008)		0.50 (0.02) ± 0.25 (.010)	0.75 (.030)	
1206	3216	3.20 (.126) ± 0.20 (.008)	1.60 (.063) ± 0.20 (.008)		0.50 (0.02) ± 0.25 (.010)	N/A	Solder Reflow Only
1210	3225	3.20 (.126) ± 0.20 (.008)	2.50 (.098) ± 0.20 (.008)		0.50 (0.02) ± 0.25 (.010)		
1808	4520	4.70 (.185) ± 0.50 (.020)	2.00 (.079) ± 0.20 (.008)		0.60 (.024) ± 0.35 (.014)		
1812	4532	4.50 (.177) ± 0.30 (.012)	3.20 (.126) ± 0.30 (.012)		0.60 (.024) ± 0.35 (.014)		
1825	4564	4.50 (.177) ± 0.30 (.012)	6.40 (.252) ± 0.40 (.016)		0.60 (.024) ± 0.35 (.014)		
2220	5650	5.70 (.224) ± 0.40 (.016)	5.00 (.197) ± 0.40 (.016)		0.60 (.024) ± 0.35 (.014)		
2225	5664	5.60 (.220) ± 0.40 (.016)	6.40 (.248) ± 0.40 (.016)		0.60 (.024) ± 0.35 (.014)		

Qualification/Certification

Commercial grade products are subject to internal qualification. Details regarding test methods and conditions are referenced in Table 4, Performance and Reliability.

Environmental Compliance

RoHS compliant

Electrical Parameters/Characteristics

Item	Parameters/Characteristics
Operating Temperature Range	-55°C to +125°C
Capacitance Change with Reference to +25°C and 0 Vdc Applied (TCC)	±30PPM/°C
Aging Rate (Max % Cap Loss/Decade Hour)	0%
Dielectric Withstanding Voltage	250% of rated voltage (5 ± 1 seconds and charge/discharge not exceeding 50mA)
Dissipation Factor (DF) Maximum Limit @ 25°C	0.1%
Insulation Resistance (IR) Limit @ 25°C	1000 megohm microfarads or 100GΩ (Rated voltage applied for 120 ± 5 secs @ 25°C)

To obtain IR limit, divide $M\Omega\text{-}\mu F$ value by the capacitance and compare to $G\Omega$ limit. Select the lower of the two limits.

Capacitance and Dissipation Factor (DF) measured under the following conditions:

1MHz ± 100kHz and 1.0Vrms ± 0.2V if capacitance ≤ 1000pF

1kHz ± 50Hz and 1.0Vrms ± 0.2V if capacitance > 1000pF

Note: When measuring capacitance it is important to ensure the set voltage level is held constant. The HP4284 & Agilent E4980 have a feature known as Automatic Level Control (ALC). The ALC feature should be switched to "ON".

Post Environmental Limits

High Temperature Life, Biased Humidity, Moisture Resistance					
Dielectric	Rated DC Voltage	Capacitance Value	DF (%)	Cap Shift	IR
C0G	All	All	0.5	0.3% or ± 0.25 pF	10% of Initial Limit

Table 1A – C0G Dielectric, (0201 - 1206 Case Sizes) con't

Cap	Cap Code	Series				C0201				C0402				C0603				C0805				C1206																			
		Voltage Code				8	4	3	8	4	3	5	1	2	8	4	3	5	1	2	8	4	3	5	1	2	8	4	3	5	1	2									
		Voltage DC				10	16	25	10	16	25	50	100	200	10	16	25	50	100	200	10	16	25	50	100	200	10	16	25	50	100	200									
		Cap Tolerance				Product Availability and Chip Thickness Codes - See Table 2 for Chip Thickness Dimensions																																			
3,300 pF	332		F	G	J	K	M											CB	CB	CB	CB	CB								DD	DD	DD	DD	DC	UD	EC	EC	EC	EC	EE	UD
3,600 pF	362		F	G	J	K	M											CB	CB	CB	CB	CB								DD	DD	DD	DD	DC	UD	EC	EC	EC	EC	EE	UD
3,900 pF	392		F	G	J	K	M											CB	CB	CB	CB	CB								DE	DE	DE	DE	DC	UD	EC	EC	EC	EC	EF	UD
4,300 pF	432		F	G	J	K	M											CB	CB	CB	CB	CB								DE	DE	DE	DE	DC	UD	EC	EC	EC	EC	EF	UD
4,700 pF	472		F	G	J	K	M											CB	CB	CB	CB	CB								DE	DE	DE	DE	DC	UD	EC	EC	EC	EC	EF	UD
5,100 pF	512		F	G	J	K	M											CB	CB	CB	CB	CB								DE	DE	DE	DE	DC	UD	ED	ED	ED	ED	ED	UD
5,600 pF	562		F	G	J	K	M											CB	CB	CB	CB	CB								DC	DC	DC	DC	DC	UD	ED	ED	ED	ED	ED	UD
6,200 pF	622		F	G	J	K	M											CB	CB	CB	CB	CB								DC	DC	DC	DC	DC	UD	EB	EB	EB	EB	EB	UD
6,800 pF	682		F	G	J	K	M											CB	CB	CB	CB	CB								DC	DC	DC	DC	DC	UD	EB	EB	EB	EB	EB	UD
7,500 pF	752		F	G	J	K	M											CB	CB	CB	CB	CB								DC	DC	DC	DC	DC	UD	EB	EB	EB	EB	EB	UD
8,200 pF	822		F	G	J	K	M											CB	CB	CB	CB	CB								DC	DC	DC	DC	DC	UD	EC	EC	EC	EC	EB	UD
9,100 pF	912		F	G	J	K	M											CB	CB	CB	CB	CB								DC	DC	DC	DC	DC	UD	EC	EC	EC	EC	EB	UD
10,000 pF	103		F	G	J	K	M											CB	CB	CB	CB	CB								DC	DC	DC	DC	DD	UD	ED	ED	ED	ED	EB	UD
12,000 pF	123		F	G	J	K	M											CB	CB	CB	CB	CB								DC	DC	DC	DC	DE	UD	EB	EB	EB	EB	EB	UD
15,000 pF	153		F	G	J	K	M											CB	CB	CB	CB	CB								DC	DC	DC	DC	DG	UD	EB	EB	EB	EB	EB	UD
18,000 pF	183		F	G	J	K	M											DC	DC	DC	DD	DD								DC	DC	DC	DD	DD	UD	EB	EB	EB	EB	EB	UD
22,000 pF	223		F	G	J	K	M																						DD	DD	DD	DF		UD	EB	EB	EB	EB	EC	UD	
27,000 pF	273		F	G	J	K	M																						DF	DF	DF			UD	EB	EB	EB	EB	EE	UD	
33,000 pF	333		F	G	J	K	M																						DG	DG	DG			UD	EB	EB	EB	EB	EE	UD	
39,000 pF	393		F	G	J	K	M																						DG	DG	DG			UD	EC	EC	EC	EE	EH	UD	
47,000 pF	473		F	G	J	K	M																						DG	DG	DG			UD	EC	EC	EC	EE	EH	UD	
56,000 pF	563		F	G	J	K	M																											UD	ED	ED	ED	EF		UD	
68,000 pF	683		F	G	J	K	M																											UD	EF	EF	EF	EH		UD	
82,000 pF	823		F	G	J	K	M																											UD	EH	EH	EH	EH		UD	
0.10 µF	104		F	G	J	K	M																											UD	EH	EH	EH			UD	
Cap	Cap Code	Voltage DC				10	16	25	10	16	25	50	100	200	10	16	25	50	100	200	10	16	25	50	100	200	10	16	25	50	100	200	10	16	25	50	100	200			
		Voltage Code				8	4	3	8	4	3	5	1	2	8	4	3	5	1	2	8	4	3	5	1	2	8	4	3	5	1	2	8	4	3	5	1	2			
		Series				C0201				C0402				C0603				C0805				C1206																			

Table 1B – (1210 - 2225 Case Sizes)

Cap	Cap Code	Series				C1210				C1808			C1812			C1825			C2220			C2225				
		Voltage Code				8	4	3	5	1	2	5	1	2	5	1	2	5	1	2	3	1	2	5	1	2
		Voltage DC				10	16	25	50	100	200	50	100	200	50	100	200	50	100	200	50	100	200	50	100	200
		Cap Tolerance				Product Availability and Chip Thickness Codes See Table 2 for Chip Thickness Dimensions																				
0.5-0.75 pF	508-758																									
1.0-2.4 pF	109-249	D																								
2.7-9.1 pF	279-919	D																								
10-13 pF	100-130	D			J	K	M	FB	FB	FB	FB	FB	FB													
15-24 pF	150-240	D			J	K	M	FB	FB	FB	FB	FB	FB													
27-51 pF	270-510	D	F	G	J	K	M	FB	FB	FB	FB	FB	FB													
56-82 pF	560-820		F	G	J	K	M	FB	FB	FB	FB	FB	FB													
91-200 pF	910-201		F	G	J	K	M	FB	FB	FB	FB	FB	FB													
220-300 pF	221-301		F	G	J	K	M	FB	FB	FB	FB	FB	FB													
330-430 pF	331-431		F	G	J	K	M	FB	FB	FB	FB	FB	FB													
470-910 pF	471-911		F	G	J	K	M	FB	FB	FB	FB	FB	FB	LF	LF	LF										
1,000 pF	102		F	G	J	K	M	FB	FB	FB	FB	FB	FB	LF	LF	LF	GB	GB	GB							
1,100 pF	112		F	G	J	K	M	FB	FB	FB	FB	FB	FB	LF	LF	LF	GB	GB	GB							
1,200 pF	122		F	G	J	K	M	FB	FB	FB	FB	FB	FB	LF	LF	LF	GB	GB	GB							
1,300 pF	132		F	G	J	K	M	FB	FB	FB	FB	FB	FB	LF	LF	LF	GB	GB	GB							
1,500 pF	152		F	G	J	K	M	FB	FB	FB	FB	FB	FE	LF	LF	LF	GB	GB	GB							
Cap	Cap Code	Voltage DC				10	16	25	50	100	200	50	100	200	50	100	200	50	100	200	50	100	200	50	100	200
		Voltage Code				8	4	3	5	1	2	5	1	2	5	1	2	5	1	2	3	1	2	5	1	2
		Series				C1210				C1808			C1812			C1825			C2220			C2225				

UD = Under Development

These products are protected under US Patents 7,172,985 & 7,670,981, other patents pending, and any foreign counterparts.

Table 1B – C0G Dielectric, (1210 - 2225 Case Sizes) con't

Cap	Cap Code	Series						C1210						C1808			C1812			C1825			C2220			C2225													
		Voltage Code						8	4	3	5	1	2	5	1	2	5	1	2	5	1	2	3	1	2	5	1	2											
		Voltage DC						10	16	25	50	100	200	50	100	200	50	100	200	50	100	200	50	100	200	50	100	200											
		Cap Tolerance						Product Availability and Chip Thickness Codes See Table 2 for Chip Thickness Dimensions																															
1,600 pF	162	F	G	J	K	M	FB	FB	FB	FB	FB	FE	LF	LF	LF	GB	GB	GB																					
1,800 pF	182	F	G	J	K	M	FB	FB	FB	FB	FB	FE	LF	LF	LF	GB	GB	GB																					
2,000 pF	202	F	G	J	K	M	FB	FB	FB	FB	FC	FE	LF	LF	LF	GB	GB	GB																					
2,200 pF	222	F	G	J	K	M	FB	FB	FB	FB	FC	FG	LF	LF	LF	GB	GB	GB																					
2,400 pF	242	F	G	J	K	M	FB	FB	FB	FB	FC	FC	LF	LF	LF																								
2,700 pF	272	F	G	J	K	M	FB	FB	FB	FB	FC	FC	LF	LF	LF	GB	GB	GB																					
3,000 pF	302	F	G	J	K	M	FB	FB	FB	FB	FC	FF	LF	LF																									
3,300 pF	332	F	G	J	K	M	FB	FB	FB	FB	FF	FF	LF	LF		GB	GB	GB																					
3,600 pF	362	F	G	J	K	M	FB	FB	FB	FB	FF	FF	LF	LF																									
3,900 pF	392	F	G	J	K	M	FB	FB	FB	FB	FF	FF	LF	LF		GB	GB	GB	HB	HB	HB																		
4,300 pF	432	F	G	J	K	M	FB	FB	FB	FB	FF	FF	LF	LF																									
4,700 pF	472	F	G	J	K	M	FF	FF	FF	FF	FG	FG	LF	LF		GB	GB	GD	HB	HB	HB														KE	KE	KE		
5,100 pF	512	F	G	J	K	M	FB	FB	FB	FB	FG	FG																								KE	KE	KE	
5,600 pF	562	F	G	J	K	M	FB	FB	FB	FB	FG	FG				GB	GB	GH	HB	HB	HB															KE	KE	KE	
6,200 pF	622	F	G	J	K	M	FB	FB	FB	FB	FG	UD																									KE	KE	KE
6,800 pF	682	F	G	J	K	M	FB	FB	FB	FB	FG	UD				GB	GB	GJ	HB	HB	HB	JB	JB	UD												KE	KE	KE	
7,500 pF	752	F	G	J	K	M	FC	FC	FC	FC	FC	UD																									KE	KE	KE
8,200 pF	822	F	G	J	K	M	FC	FC	FC	FC	FC	UD				GB	GH	UD	HB	HB	HB	JB	JB	UD												KE	KE	KE	
9,100 pF	912	F	G	J	K	M	FE	FE	FE	FE	FE	UD																									KE	KE	KE
10,000 pF	103	F	G	J	K	M	FF	FF	FF	FF	FF	UD				GB	GH	UD	HB	HB	HE	JB	JB	UD													KE	KE	KE
12,000 pF	123	F	G	J	K	M	FG	FG	FG	FG	FB	UD				GB	GG	UD	HB	HB	HE	JB	JB	UD													KE	KE	KE
15,000 pF	153	F	G	J	K	M	FG	FG	FG	FG	FB	UD				GB	GB	UD	HB	HB		JB	JB	UD													KE	KE	KE
18,000 pF	183	F	G	J	K	M	FB	FB	FB	FB	FB	UD				GB	GB	UD	HB	HE		JB	JB	UD													KE	KE	
22,000 pF	223	F	G	J	K	M	FB	FB	FB	FB	FB	UD				GB	GB	UD	HB	HE		JB	JB	UD													KE	KE	
27,000 pF	273	F	G	J	K	M	FB	FB	FB	FB	FB	UD				GB	GB	UD	HB	HG		JB	JB	UD												KE	KE		
33,000 pF	333	F	G	J	K	M	FB	FB	FB	FB	FB	UD				GB	GB	UD				JB	JB	UD											KE				
39,000 pF	393	F	G	J	K	M	FB	FB	FB	FB	FE	UD				GB	GB	UD				JB	JB	UD															
47,000 pF	473	F	G	J	K	M	FB	FB	FB	FB	FE	UD				GB	GB	UD				JB	JB	UD															
56,000 pF	563	F	G	J	K	M	FB	FB	FB	FB	FF	UD				GB	GB	UD				JB	JB	UD															
68,000 pF	683	F	G	J	K	M	FB	FB	FB	FC	FG	UD				GB	GB	UD				JB	JB	UD															
82,000 pF	823	F	G	J	K	M	FC	FC	FC	FF	FH	UD				GB	GB	UD				JB	JB	UD															
0.10 µF	104	F	G	J	K	M	FE	FE	FE	FG	FM	UD				GB	GD	UD				JB	JB	UD															
0.12 µF	124	F	G	J	K	M	FG	FG	FG	FH		UD				GB	GH	UD				JB	JB	UD															
0.15 µF	154	F	G	J	K	M	FH	FH	FH	FM		UD				GD	GN	UD				JB	JB	UD															
0.18 µF	184	F	G	J	K	M	FJ	FJ	FJ			UD				GH		UD				JB	JD	UD															
0.22 µF	224	F	G	J	K	M	FK	FK	FK			UD				GK		UD				JB	JD	UD															
0.27 µF	274	F	G	J	K	M						UD										JB	JF	UD															
0.33 µF	334	F	G	J	K	M						UD										JD	JG	UD															
0.47 µF	474	F	G	J	K	M						UD												UD															
0.56 µF	564	F	G	J	K	M						UD												UD															
0.68 µF	684	F	G	J	K	M						UD												UD															
0.82 µF	824	F	G	J	K	M						UD												UD															
1.0 µF	105	F	G	J	K	M						UD												UD															
Cap	Cap Code	Voltage DC						10	16	25	50	100	200	50	100	200	50	100	200	50	100	200	50	100	200	50	100	200	50	100	200	50	100	200	50	100	200		
		Voltage Code						8	4	3	5	1	2	5	1	2	5	1	2	5	1	2	3	1	2	5	1	2	5	1	2	5	1	2	5	1	2		
		Series						C1210						C1808			C1812			C1825			C2220			C2225													

UD = Under Development

These products are protected under US Patents 7,172,985 & 7,670,981, other patents pending, and any foreign counterparts.

Overview

KEMET's X7R dielectric features a 125°C maximum operating temperature and is considered "temperature stable." The Electronics Components, Assemblies & Materials Association (EIA) characterizes X7R dielectric as a Class II material. Components of this classification are fixed, ceramic dielectric capacitors suited for bypass and decoupling applications or for frequency discriminating circuits where Q and stability of capacitance characteristics are not critical. X7R exhibits a predictable change in capacitance with respect to time and

voltage and boasts a minimal change in capacitance with reference to ambient temperature. Capacitance change is limited to ±15% from -55°C to +125°C.

Benefits

- -55°C to +125°C operating temperature range
- Pb-Free and RoHS compliant
- Temperature stable dielectric
- EIA 0402, 0603, 0805, 1206, 1210, 1808, 1812, 1825, 2220 and 2225 case sizes
- DC voltage ratings of 6.3V, 10V, 16V, 25V, 50V, 100V, 200V and 250V
- Capacitance offerings ranging from 150pF to 47µF
- Available capacitance tolerances of ±5%, ±10% and ±20%
- Non-polar device, minimizing installation concerns
- 100% pure matte tin-plated termination finish allowing for excellent solderability
- SnPb termination finish option available upon request (5% min)

Applications

Typical applications include decoupling, bypass, filtering and transient voltage suppression.

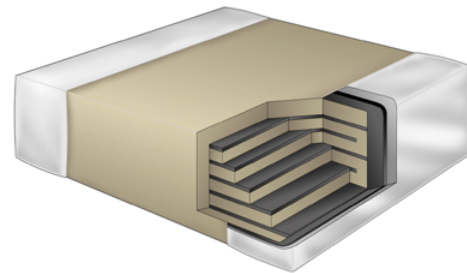

Ordering Information

C	1206	C	106	M	4	R	A	C	TU
Ceramic	Case Size (L" x W")	Specification/ Series	Capacitance Code (pF)	Capacitance Tolerance	Voltage	Dielectric	Failure Rate/ Design	Termination Finish ²	Packaging/Grade (C-Spec) ²
	0402 0603 0805 1206 1210 1808 1812 1825 2220 2225	C = Standard	2 Sig. Digits + Number of Zeros	J = ±5% K = ±10% M = ±20%	9 = 6.3 8 = 10V 4 = 16V 3 = 25V 6 = 35V 5 = 50V 1 = 100V 2 = 200V A = 250V	R = X7R	A = N/A	C = 100% Matte Sn	Blank = Bulk TU = 7" Reel Unmarked TM = 7" Reel Marked

¹ Additional termination finish options may be available. Contact KEMET for details.

² Additional reeling or packaging options may be available. Contact KEMET for details.

Dimensions – Millimeters (Inches)

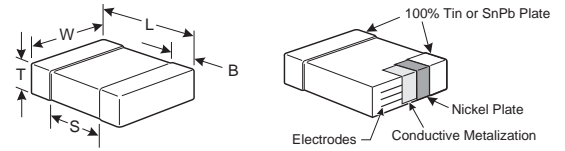

EIA Size Code	Metric Size Code	L Length	W Width	T Thickness	B Bandwidth	S Separation Min.	Mounting Technique
0402	1005	1.00 (.040) ± 0.05 (.002)	0.50 (.020) ± 0.05 (.002)	See Table 2 for Thickness	0.30 (.012) ± 0.10 (.004)	0.30 (.012)	Solder Reflow Only
0603	1608	1.60 (.063) ± 0.15 (.006)	0.80 (.032) ± 0.15 (.006)		0.35 (.014) ± 0.15 (.006)	0.70 (.028)	Solder Wave or Solder Reflow
0805	2012	2.00 (.079) ± 0.20 (.008)	1.25 (.049) ± 0.20 (.008)		0.50 (0.02) ± 0.25 (.010)	0.75 (.030)	
1206	3216	3.20 (.126) ± 0.20 (.008)	1.60 (.063) ± 0.20 (.008)		0.50 (0.02) ± 0.25 (.010)	N/A	Solder Reflow Only
1210	3225	3.20 (.126) ± 0.20 (.008)	2.50 (.098) ± 0.20 (.008)		0.50 (0.02) ± 0.25 (.010)		
1808	4520	4.70 (.185) ± 0.50 (.020)	2.00 (.079) ± 0.20 (.008)		0.60 (.024) ± 0.35 (.014)		
1812	4532	4.50 (.177) ± 0.30 (.012)	3.20 (.126) ± 0.30 (.012)		0.60 (.024) ± 0.35 (.014)		
1825	4564	4.50 (.177) ± 0.30 (.012)	6.40 (.252) ± 0.40 (.016)		0.60 (.024) ± 0.35 (.014)		
2220	5650	5.70 (.224) ± 0.40 (.016)	5.00 (.197) ± 0.40 (.016)		0.60 (.024) ± 0.35 (.014)		
2225	5664	5.60 (.220) ± 0.40 (.016)	6.40 (.248) ± 0.40 (.016)		0.60 (.024) ± 0.35 (.014)		

Qualification/Certification

Commercial grade products are subject to internal qualification. Details regarding test methods and conditions are referenced in Table 4, Performance and Reliability.

Environmental Compliance

Pb-Free and RoHS compliant

Electrical Parameters/Characteristics

Item	Parameters/Characteristics
Operating Temperature Range	-55°C to +125°C
Capacitance Change with Reference to +25°C and 0 Vdc Applied (TCC)	±15%
Aging Rate (Max % Cap Loss/Decade Hour)	3.0%
Dielectric Withstanding Voltage	250% of rated voltage (5 ± 1 seconds and charge/discharge not exceeding 50mA)
Dissipation Factor (DF) Maximum Limits @ 25°C	5%(10V), 3.5%(16V & 25V) and 2.5%(50V to 250V)
Insulation Resistance (IR) Limit @ 25°C	See Insulation Resistance Limit Table (Rated voltage applied for 120 ± 5 secs @ 25°C)

Regarding Aging Rate: Capacitance measurements (including tolerance) are indexed to a referee time of 48 or 1000 Hours. Please refer to a part number specific datasheet for referee time details.

To obtain IR limit, divide $M\Omega\text{-}\mu F$ value by the capacitance and compare to $G\Omega$ limit. Select the lower of the two limits.

Capacitance and Dissipation Factor (DF) measured under the following conditions:

1kHz ± 50Hz and 1.0 ± 0.2 Vrms if capacitance $\leq 10\mu F$

120Hz ± 10Hz and 0.5 ± 0.1 Vrms if capacitance $> 10\mu F$

Note: When measuring capacitance it is important to ensure the set voltage level is held constant. The HP4284 & Agilent E4980 have a feature known as Automatic Level Control (ALC). The ALC feature should be switched to "ON".

Post Environmental Limits

High Temperature Life, Biased Humidity, Moisture Resistance					
Dielectric	Rated DC Voltage	Capacitance Value	DF (%)	Cap Shift	IR
X7R	>25	All	3.0	± 20%	10% of Initial Limit
	16 / 25		5.0		
	< 16		7.5		

Insulation Resistance Limit Table

EIA Case Size	1000 megohm microfarads or 100GΩ	500 megohm microfarads or 10GΩ
0201	N/A	ALL
0402	< .012μF	≥ .012μF
0603	< .047μF	≥ .047μF
0805	< .047μF	≥ .047μF
1206	< 0.22μF	≥ 0.22μF
1210	< 0.39μF	≥ 0.39μF
1808	ALL	N/A
1812	< 2.2μF	≥ 2.2μF
1825	ALL	N/A
2220	< 10μF	≥ 10μF
2225	ALL	N/A

Table 1A – X7R Dielectric, (0402 - 1206 Case Sizes)

Cap	Cap Code	Series		C0402					C0603						C0805									C1206																					
		Voltage Code		9	8	4	3	5	9	8	4	3	5	1	2	9	8	4	3	6	5	1	2	A	9	8	4	3	6	5	1	2	A												
		Voltage DC		6.3	10	16	25	50	6.3	10	16	25	50	100	200	6.3	10	16	25	35	50	100	200	250	6.3	10	16	25	35	50	100	200	250												
Cap Tolerance		Product Availability and Chip Thickness Codes - See Table 2 for Chip Thickness Dimensions																																											
150 pF	151	J	K	M	BB	BB	BB	BB	BB	CB	CB	CB	CB	CB	CB	DC	DC	DC	DC	DC	DC	DC	DC	DC	DC	DC	DC	DC	DC	DC	DC	DC	DC	DC	DC	DC	DC	DC	DC						
180 pF	181	J	K	M	BB	BB	BB	BB	BB	CB	CB	CB	CB	CB	CB	DC	DC	DC	DC	DC	DC	DC	DC	DC	DC	DC	DC	DC	DC	DC	DC	DC	DC	DC	DC	DC	DC	DC	DC	DC	DC				
220 pF	221	J	K	M	BB	BB	BB	BB	BB	CB	CB	CB	CB	CB	CB	DC	DC	DC	DC	DC	DC	DC	DC	DC	DC	DC	DC	DC	DC	DC	DC	DC	DC	DC	DC	DC	DC	DC	DC	DC	DC	DC			
270 pF	271	J	K	M	BB	BB	BB	BB	BB	CB	CB	CB	CB	CB	CB	DC	DC	DC	DC	DC	DC	DC	DC	DC	DC	DC	DC	DC	DC	DC	DC	DC	DC	DC	DC	DC	DC	DC	DC	DC	DC	DC			
330 pF	331	J	K	M	BB	BB	BB	BB	BB	CB	CB	CB	CB	CB	CB	DC	DC	DC	DC	DC	DC	DC	DC	DC	DC	DC	DC	DC	DC	DC	DC	DC	DC	DC	DC	DC	DC	DC	DC	DC	DC	DC			
390 pF	391	J	K	M	BB	BB	BB	BB	BB	CB	CB	CB	CB	CB	CB	DC	DC	DC	DC	DC	DC	DC	DC	DC	DC	DC	DC	DC	DC	DC	DC	DC	DC	DC	DC	DC	DC	DC	DC	DC	DC	DC			
470 pF	471	J	K	M	BB	BB	BB	BB	BB	CB	CB	CB	CB	CB	CB	DC	DC	DC	DC	DC	DC	DC	DC	DC	DC	DC	DC	DC	DC	DC	DC	DC	DC	DC	DC	DC	DC	DC	DC	DC	DC	DC			
560 pF	561	J	K	M	BB	BB	BB	BB	BB	CB	CB	CB	CB	CB	CB	DC	DC	DC	DC	DC	DC	DC	DC	DC	DC	DC	DC	DC	DC	DC	DC	DC	DC	DC	DC	DC	DC	DC	DC	DC	DC	DC			
680 pF	681	J	K	M	BB	BB	BB	BB	BB	CB	CB	CB	CB	CB	CB	DC	DC	DC	DC	DC	DC	DC	DC	DC	DC	DC	DC	DC	DC	DC	DC	DC	DC	DC	DC	DC	DC	DC	DC	DC	DC	DC			
820 pF	821	J	K	M	BB	BB	BB	BB	BB	CB	CB	CB	CB	CB	CB	DC	DC	DC	DC	DC	DC	DC	DC	DC	DC	DC	DC	DC	DC	DC	DC	DC	DC	DC	DC	DC	DC	DC	DC	DC	DC	DC			
1,000 pF	102	J	K	M	BB	BB	BB	BB	BB	CB	CB	CB	CB	CB	CB	DC	DC	DC	DC	DC	DC	DC	DC	DC	DC	DC	DC	DC	DC	DC	DC	DC	DC	DC	DC	DC	DC	DC	DC	DC	DC	DC			
1,200 pF	122	J	K	M	BB	BB	BB	BB	BB	CB	CB	CB	CB	CB	CB	DC	DC	DC	DC	DC	DC	DC	DC	DC	DC	DC	DC	DC	DC	DC	DC	DC	DC	DC	DC	DC	DC	DC	DC	DC	DC	DC	DC		
1,500 pF	152	J	K	M	BB	BB	BB	BB	BB	CB	CB	CB	CB	CB	CB	DC	DC	DC	DC	DC	DC	DC	DC	DC	DC	DC	DC	DC	DC	DC	DC	DC	DC	DC	DC	DC	DC	DC	DC	DC	DC	DC	DC		
1,800 pF	182	J	K	M	BB	BB	BB	BB	BB	CB	CB	CB	CB	CB	CB	DC	DC	DC	DC	DC	DC	DC	DC	DC	DC	DC	DC	DC	DC	DC	DC	DC	DC	DC	DC	DC	DC	DC	DC	DC	DC	DC	DC		
2,200 pF	222	J	K	M	BB	BB	BB	BB	BB	CB	CB	CB	CB	CB	CB	DC	DC	DC	DC	DC	DC	DC	DC	DC	DC	DC	DC	DC	DC	DC	DC	DC	DC	DC	DC	DC	DC	DC	DC	DC	DC	DC	DC		
2,700 pF	272	J	K	M	BB	BB	BB	BB	BB	CB	CB	CB	CB	CB	CB	DC	DC	DC	DC	DC	DC	DC	DC	DC	DC	DC	DC	DC	DC	DC	DC	DC	DC	DC	DC	DC	DC	DC	DC	DC	DC	DC	DC		
3,300 pF	332	J	K	M	BB	BB	BB	BB	BB	CB	CB	CB	CB	CB	CB	DC	DC	DC	DC	DC	DC	DC	DC	DC	DC	DC	DC	DC	DC	DC	DC	DC	DC	DC	DC	DC	DC	DC	DC	DC	DC	DC	DC		
3,900 pF	392	J	K	M	BB	BB	BB	BB	BB	CB	CB	CB	CB	CB	CB	DC	DC	DC	DC	DC	DC	DC	DC	DC	DC	DC	DC	DC	DC	DC	DC	DC	DC	DC	DC	DC	DC	DC	DC	DC	DC	DC	DC		
4,700 pF	472	J	K	M	BB	BB	BB	BB	BB	CB	CB	CB	CB	CB	CB	DC	DC	DC	DC	DC	DC	DC	DC	DC	DC	DC	DC	DC	DC	DC	DC	DC	DC	DC	DC	DC	DC	DC	DC	DC	DC	DC	DC		
5,600 pF	562	J	K	M	BB	BB	BB	BB	BB	CB	CB	CB	CB	CB	CB	DC	DC	DC	DC	DC	DC	DC	DC	DC	DC	DC	DC	DC	DC	DC	DC	DC	DC	DC	DC	DC	DC	DC	DC	DC	DC	DC	DC		
6,800 pF	682	J	K	M	BB	BB	BB	BB	BB	CB	CB	CB	CB	CB	CB	DC	DC	DC	DC	DC	DC	DC	DC	DC	DC	DC	DC	DC	DC	DC	DC	DC	DC	DC	DC	DC	DC	DC	DC	DC	DC	DC	DC		
8,200 pF	822	J	K	M	BB	BB	BB	BB	BB	CB	CB	CB	CB	CB	CB	DC	DC	DC	DC	DC	DC	DC	DC	DC	DC	DC	DC	DC	DC	DC	DC	DC	DC	DC	DC	DC	DC	DC	DC	DC	DC	DC	DC	DC	
10,000 pF	103	J	K	M	BB	BB	BB	BB	BB	CB	CB	CB	CB	CB	CB	DC	DC	DC	DC	DC	DC	DC	DC	DC	DC	DC	DC	DC	DC	DC	DC	DC	DC	DC	DC	DC	DC	DC	DC	DC	DC	DC	DC	DC	
12,000 pF	123	J	K	M	BB	BB	BB	BB	BB	CB	CB	CB	CB	CB	CB	DC	DC	DC	DC	DC	DC	DC	DC	DC	DC	DC	DC	DC	DC	DC	DC	DC	DC	DC	DC	DC	DC	DC	DC	DC	DC	DC	DC	DC	
15,000 pF	153	J	K	M	BB	BB	BB	BB	BB	CB	CB	CB	CB	CB	CB	DC	DC	DC	DC	DC	DC	DC	DC	DC	DC	DC	DC	DC	DC	DC	DC	DC	DC	DC	DC	DC	DC	DC	DC	DC	DC	DC	DC	DC	
18,000 pF	183	J	K	M	BB	BB	BB	BB	BB	CB	CB	CB	CB	CB	CB	DC	DC	DC	DC	DC	DC	DC	DC	DC	DC	DC	DC	DC	DC	DC	DC	DC	DC	DC	DC	DC	DC	DC	DC	DC	DC	DC	DC	DC	
22,000 pF	223	J	K	M	BB	BB	BB	BB	BB	CB	CB	CB	CB	CB	CB	DC	DC	DC	DC	DC	DC	DC	DC	DC	DC	DC	DC	DC	DC	DC	DC	DC	DC	DC	DC	DC	DC	DC	DC	DC	DC	DC	DC	DC	
27,000 pF	273	J	K	M	BB	BB	BB	BB	BB	CB	CB	CB	CB	CB	CB	DC	DC	DC	DC	DC	DC	DC	DC	DC	DC	DC	DC	DC	DC	DC	DC	DC	DC	DC	DC	DC	DC	DC	DC	DC	DC	DC	DC	DC	
33,000 pF	333	J	K	M	BB	BB	BB	BB	BB	CB	CB	CB	CB	CB	CB	DC	DC	DC	DC	DC	DC	DC	DC	DC	DC	DC	DC	DC	DC	DC	DC	DC	DC	DC	DC	DC	DC	DC	DC	DC	DC	DC	DC	DC	
39,000 pF	393	J	K	M	BB	BB	BB	BB	BB	CB	CB	CB	CB	CB	CB	DC	DC	DC	DC	DC	DC	DC	DC	DC	DC	DC	DC	DC	DC	DC	DC	DC	DC	DC	DC	DC	DC	DC	DC	DC	DC	DC	DC	DC	
47,000 pF	473	J	K	M	BB	BB	BB	BB	BB	CB	CB	CB	CB	CB	CB	DC	DC	DC	DC	DC	DC	DC	DC	DC	DC	DC	DC	DC	DC	DC	DC	DC	DC	DC	DC	DC	DC	DC	DC	DC	DC	DC	DC	DC	
56,000 pF	563	J	K	M	BB	BB	BB	BB	BB	CB	CB	CB	CB	CB	CB	DC	DC	DC	DC	DC	DC	DC	DC	DC	DC	DC	DC	DC	DC	DC	DC	DC	DC	DC	DC	DC	DC	DC	DC	DC	DC	DC	DC	DC	DC
68,000 pF	683	J	K	M	BB	BB	BB	BB	BB	CB	CB	CB	CB	CB	CB	DC	DC	DC	DC	DC	DC	DC	DC	DC	DC	DC	DC	DC	DC	DC	DC	DC	DC	DC	DC	DC	DC	DC	DC	DC	DC	DC	DC	DC	DC
82,000 pF	823	J	K	M	BB	BB	BB	BB	BB	CB	CB	CB	CB	CB	CB	DC	DC	DC	DC	DC	DC	DC	DC	DC	DC	DC	DC	DC	DC	DC	DC	DC	DC	DC	DC	DC	DC	DC	DC	DC	DC	DC	DC	DC	DC
0.10 µF	104	J	K	M	BB	BB	BB	BB	BB	CB	CB	CB	CB	CB	CB	DC	DC	DC	DC	DC	DC	DC	DC	DC	DC	DC	DC	DC	DC	DC	DC	DC	DC	DC	DC	DC	DC	DC	DC	DC	DC	DC	DC	DC	
0.12 µF	124	J	K	M						CB	CB	CB	CB	CB		DC	DC	DC	DC	DC	DC	DC	DC	DC	DC	DC	DC	DC	DC	DC	DC	DC	DC	DC	DC	DC	DC	DC	DC	DC	DC	DC	DC	DC	
0.15 µF	154	J	K	M						CB	CB	CB	CB	CD		DC	DC	DC	DC	DC	DC	DC	DC	DC	DC	DC	DC	DC	DC	DC	DC	DC	DC	DC	DC	DC	DC	DC	DC	DC	DC	DC	DC	DC	
0.18 µF	184	J	K	M						CB	CB	CB	CB			DC	DC	DC	DC	DC	DC	DC	DC	DC	DC	DC	DC	DC	DC	DC	DC	DC	DC	DC	DC	DC	DC	DC	DC	DC	DC	DC	DC	DC	
0.22 µF	224	J	K	M						CB	CB	CB	CB	UD		DC	DC	DC	DC	DC	DC	DC	DC	DC	DC	DC	DC	DC	DC	DC	DC	DC	DC	DC	DC	DC	DC	DC	DC	DC	DC	DC	DC	DC	DC
0.27 µF	274	J	K	M						CB	CB	CB	CB			DC	DC	DC	DC	DC	DC	DC	DC	DC	DC	DC	DC	DC	DC	DC	DC	DC	DC	DC	DC	DC	DC	DC	DC	DC	DC	DC	DC	DC	DC
0.33 µF	334	J	K	M						CB	CB	CB	CB			DC	DC	DC	DC	DC	DC	DC	DC	DC	DC	DC	DC	DC	DC	DC	DC	DC	DC	DC	DC	DC	DC	DC	DC	DC	DC	DC	DC	DC	DC
0.39 µF	394	J	K	M						CB	CB	CB	CB			DC	DC	DC	DC	DC	DC	DC	DC	DC	DC	DC	DC	DC	DC	DC	DC	DC	DC	DC	DC	DC	DC	DC	DC	DC	DC	DC	DC	DC	DC
0.47 µF	474	J	K	M						CB	CB	CB	CB			DC	DC	DC	DC</																										

Table 1A – X7R Dielectric, (0402 - 1206 Case Sizes) con't

Cap	Cap Code	Series	C0402					C0603					C0805					C1206														
		Voltage Code	9	8	4	3	5	9	8	4	3	5	1	2	9	8	4	3	6	5	1	2	A	9	8	4	3	6	5	1	2	A
		Voltage DC	6.3	10	16	25	50	6.3	10	16	25	50	100	200	6.3	10	16	25	35	50	100	200	250	6.3	10	16	25	35	50	100	200	250
Cap Tolerance	Product Availability and Chip Thickness Codes - See Table 2 for Chip Thickness Dimensions																															
6.8 µF	685	J K M																					EH	EH	EH							
8.2 µF	825	J K M											UD	UD										EH	EH	EH						
10 µF	106	J K M																						EH	EH	EH	UD	UD	UD			
12 µF	126	J K M																														
15 µF	156	J K M																														
18 µF	186	J K M																														
22 µF	226	J K M																						UD	UD							
47 µF	476	J K M																														
Cap	Cap Code	Voltage DC	6.3	10	16	25	50	6.3	10	16	25	50	100	200	6.3	10	16	25	35	50	100	200	250	6.3	10	16	25	35	50	100	200	250
		Voltage Code	9	8	4	3	5	9	8	4	3	5	1	2	9	8	4	3	6	5	1	2	A	9	8	4	3	6	5	1	2	A
		Series	C0402					C0603					C0805					C1206														

Table 1B – (1210 - 2225 Case Sizes)

Cap	Cap Code	Series	C1210							C1808			C1812				C1825				C2220					C2225									
		Voltage Code	9	8	4	3	5	1	2	A	5	1	2	3	5	1	2	A	5	1	2	A	3	5	1	2	A	5	1	2	A				
		Voltage DC	6.3	10	16	25	50	100	200	250	50	100	200	25	50	100	200	250	50	100	200	250	25	50	100	200	250	50	100	200	250				
Cap Tolerance	Product Availability and Chip Thickness Codes - See Table 2 for Chip Thickness Dimensions																																		
2,200 pF	222	J K M	FB	FB	FB	FB	FB	FB	FB	FB	FB																								
2,700 pF	272	J K M	FB	FB	FB	FB	FB	FB	FB	FB	FB																								
3,300 pF	332	J K M	FB	FB	FB	FB	FB	FB	FB	FB	FB																								
3,900 pF	392	J K M	FB	FB	FB	FB	FB	FB	FB	FB	FB																								
4,700 pF	472	J K M	FB	FB	FB	FB	FB	FB	FB	FB	FB	LD	LD	LD																					
5,600 pF	562	J K M	FB	FB	FB	FB	FB	FB	FB	FB	FB	LD	LD	LD																					
6,800 pF	682	J K M	FB	FB	FB	FB	FB	FB	FB	FB	FB	LD	LD	LD	GB	GB	GB	GB	GB																
8,200 pF	822	J K M	FB	FB	FB	FB	FB	FB	FB	FB	FB	LD	LD	LD	GB	GB	GB	GB	GB																
10,000 pF	103	J K M	FB	FB	FB	FB	FB	FB	FB	FB	FB	LD	LD	LD	GB	GB	GB	GB	GB																
12,000 pF	123	J K M	FB	FB	FB	FB	FB	FB	FB	FB	FB	LD	LD	LD	GB	GB	GB	GB	GB																
15,000 pF	153	J K M	FB	FB	FB	FB	FB	FB	FB	FB	FB	LD	LD	LD	GB	GB	GB	GB	GB																
18,000 pF	183	J K M	FB	FB	FB	FB	FB	FB	FB	FB	FB	LD	LD	LD	GB	GB	GB	GB	GB																
22,000 pF	223	J K M	FB	FB	FB	FB	FB	FB	FB	FB	FB	LD	LD	LD	GB	GB	GB	GB	GB	HB	HB	HB	HB												
27,000 pF	273	J K M	FB	FB	FB	FB	FB	FB	FB	FB	FB	LD	LD	LD	GB	GB	GB	GB	GB	HB	HB	HB	HB												
33,000 pF	333	J K M	FB	FB	FB	FB	FB	FB	FB	FB	FB	LD	LD	LD	GB	GB	GB	GB	GB	HB	HB	HB	HB												
39,000 pF	393	J K M	FB	FB	FB	FB	FB	FB	FB	FB	FB	LD	LD	LD	GB	GB	GB	GB	GB	HB	HB	HB	HB												
47,000 pF	473	J K M	FB	FB	FB	FB	FB	FB	FB	FB	FC	FC	FC	LD	LD	LD	LD	LD	GB	GB	GB	GB							KC	KC	KC	KC			
56,000 pF	563	J K M	FB	FB	FB	FB	FB	FB	FB	FB	FC	FC	FC	LD	LD	LD	LD	LD	GB	GB	GB	GB	HB	HB	HB	HB					KC	KC	KC	KC	
68,000 pF	683	J K M	FB	FB	FB	FB	FB	FB	FB	FB	FC	FC	LD						GB	GB	GB	GB	HB	HB	HB	HB					KC	KC	KC	KC	
82,000 pF	823	J K M	FB	FB	FB	FB	FB	FB	FB	FC	FF	FF	LD						GB	GB	GB	GB	HB	HB	HB	HB	JC	JC	JC	JC	JC	KC	KC	KC	KC
0.10 µF	104	J K M	FB	FB	FB	FB	FB	FD	FD	FG	FG	LD						GB	GB	GB	GB	HB	HB	HB	HB	JC	JC	JC	JC	JC	KC	KC	KC	KC	
0.12 µF	124	J K M	FB	FB	FB	FB	FB	FD	FD			LD						GB	GB	GB	GB	HB	HB	HB	HB	JC	JC	JC	JC	JC	KC	KC	KC	KC	
0.15 µF	154	J K M	FC	FC	FC	FC	FC	FD	FD			LD						GB	GB	GB	GE	GE	HB	HB	HB	HB	JC	JC	JC	JC	JC	KC	KC	KC	KC
0.18 µF	184	J K M	FC	FC	FC	FC	FC	FD	FD			LD						GB	GB	GB	GF	GG	HB	HB	HB	HB	JC	JC	JC	JC	JC	KC	KC	KC	KC
Cap	Cap Code	Voltage DC	6.3	10	16	25	50	100	200	250	50	100	200	25	50	100	200	250	50	100	200	250	25	50	100	200	250	50	100	200	250				
		Voltage Code	9	8	4	3	5	1	2	A	5	1	2	3	5	1	2	A	5	1	2	A	3	5	1	2	A	5	1	2	A				
		Series	C1210							C1808			C1812				C1825				C2220					C2225									

UD = Under Development

Table 1B – X7R Dielectric, (1210 - 2225 Case Sizes) con't

Cap	Cap Code	Series	C1210								C1808			C1812					C1825				C2220					C2225						
			Voltage Code	9	8	4	3	5	1	2	A	5	1	2	3	5	1	2	A	5	1	2	A	3	5	1	2	A	5	1	2	A		
			Voltage DC	63	10	16	25	50	100	200	250	50	100	200	25	50	100	200	250	50	100	200	250	25	50	100	200	250	50	100	200	250		
			Cap Tolerance	Product Availability and Chip Thickness Codes - See Table 2 for Chip Thickness Dimensions																														
0.22 uF	224	J K M	FC	FC	FC	FC	FC	FD							GB	GB	GB	GG	GG	GB	HB	HB	HB	HB	JC	JC	JC	JC	JC	KC	KC	KC	KC	
0.27 uF	274	J K M	FC	FC	FC	FC	FC	FD							GB	GB	GG	GG	GG	GB	HB	HB	HB	HB	JC	JC	JC	JC	JC	KC	KC	KC	KC	
0.33 uF	334	J K M	FD	FD	FD	FD	FD	FD							GB	GB	GG	GG	GG	GB	HB	HB	HB	HB	JC	JC	JC	JC	JC	KC	KC	KC	KC	
0.39 uF	394	J K M	FD	FD	FD	FD	FD	FD							GB	GB	GG	GG	GG	GB	HB	HB	HD	HD	JC	JC	JC	JC	JC	KC	KC	KC	KC	
0.47 uF	474	J K M	FD	FD	FD	FD	FD	FD							GB	GB	GG	GJ	GJ	GB	HB	HB	HD	HD	JC	JC	JC	JC	JC	KC	KC	KD	KD	
0.56 uF	564	J K M	FD	FD	FD	FD	FD	FF							GC	GC	GG			GB	HB	HD	HD	HD	JC	JC	JC	JD	JD	KB	KC	KD	KD	
0.68 uF	684	J K M	FD	FD	FD	FD	FD	FG							GC	GC	GG			GB	HB	HD	HD	HD	JC	JC	JD	JD	JD	KB	KC	KD	KD	
0.82 uF	824	J K M	FF	FF	FF	FF	FF	FL							GE	GE	GG			GB	HB	HF	HF	HF	JC	JC	JF	JF	JF	KB	KC	KE	KE	
1.0 uF	105	J K M	FH	FH	FH	FH	FH	FM							GE	GE	GG			GB	HB	HF	HF	HF	JC	JC	JF	JF	JF	KB	KD	KE	KE	
1.2 uF	125	J K M	FH	FH	FH	FH	FG													GB	HB				JC	JC				KB	KE	KE	KE	
1.5 uF	155	J K M	FH	FH	FH	FH	FG														HC				JC	JC				KC				
1.8 uF	185	J K M	FH	FH	FH	FH	FG														HD				JD	JD				KD				
2.2 uF	225	J K M	FJ	FJ	FJ	FJ	FG	FT							GO ²	GO ²	GO ²				HF				JF	JF				KD				
2.7 uF	275	J K M	FE	FE	FE	FE	FG	FH																										
3.3 uF	335	J K M	FF	FF	FF	FM	FM																											
3.9 uF	395	J K M	FG	FG	FG	FG	FK																											
4.7 uF	475	J K M	FC	FC	FC	FG	FS								GK	GK																		
5.6 uF	565	J K M	FF	FF	FF	FH																												
6.8 uF	685	J K M	FG	FG	FG	FM																												
8.2 uF	825	J K M	FH	FH	FH	FK																												
10 uF	106	J K M	FH	FH	FH	FS	UD								GK										JF	JO								
12 uF	126	J K M																																
15 uF	156	J K M																								JO								
18 uF	186	J K M																																
22 uF	226	J K M	FS	FS	UD	UD																				JO								
47 uF	476	J K M	FS ¹	UD																														
Cap	Cap Code	Series	C1210								C1808			C1812					C1825				C2220					C2225						
			Voltage DC	63	10	16	25	50	100	200	250	50	100	200	25	50	100	200	250	50	100	200	250	25	50	100	200	250	50	100	200	250		
			Voltage Code	9	8	4	3	5	1	2	A	5	1	2	3	5	1	2	A	5	1	2	A	3	5	1	2	A	5	1	2	A		

UD = Under Development

xx¹ Available only in K,M tolerance

xx² Available only in M tolerance.

Surface Mount Multilayer Ceramic Chip Capacitors (SMD MLCCs) X5R Dielectric, 4VDC-50VDC (Commercial Grade)

Overview

KEMET's X5R dielectric features an 85°C maximum operating temperature and is considered "semi-stable." The Electronics Components, Assemblies & Materials Association (EIA) characterizes X5R dielectric as a Class II material. Components of this classification are fixed, ceramic dielectric capacitors suited for bypass and decoupling applications or for frequency discriminating circuits where Q and stability of capacitance characteristics are not critical. X5R exhibits a predictable change

in capacitance with respect to time and voltage and boasts a minimal change in capacitance with reference to ambient temperature. Capacitance change is limited to $\pm 15\%$ from -55°C to +85°C.

Benefits

- -55°C to +85°C operating temperature range
- Pb-Free and RoHS compliant
- Temperature stable dielectric
- EIA 0201, 0402, 0603, 0805, 1206, and 1210 case sizes
- DC voltage ratings of 4V, 6.3V, 10V, 16V, 25V, 35V and 50V
- Capacitance offerings ranging from .01 μF to 100 μF
- Available capacitance tolerances of $\pm 10\%$ and $\pm 20\%$
- Non-polar device, minimizing installation concerns
- 100% pure matte tin-plated termination finish allowing for excellent solderability

Applications

Typical applications include decoupling, bypass, and filtering.

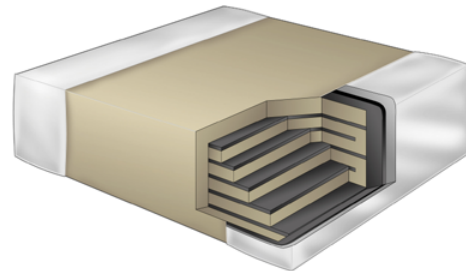

Ordering Information

C	1206	C	107	M	9	P	A	C	TU
Ceramic	Case Size (L" x W")	Specification/ Series	Capacitance Code (pF)	Capacitance Tolerance	Voltage	Dielectric	Failure Rate/ Design	Termination Finish ²	Packaging/Grade (C-Spec) ²
	1005 = 01005 0201 0402 0603 0805 1206 1210	C = Standard	2 Sig. Digits + Number of Zeros	K = $\pm 10\%$ M = $\pm 20\%$	7 = 4V 9 = 6.3V 8 = 10V 4 = 16V 3 = 25V 6 = 35V 5 = 50V	P = X5R	A = N/A	C = 100% Matte Sn	Blank = Bulk TU = 7" Reel Unmarked TM = 7" Reel Marked

¹ Additional termination finish options may be available. Contact KEMET for details.

² Additional reeling or packaging options may be available. Contact KEMET for details.

Dimensions – Millimeters (Inches)

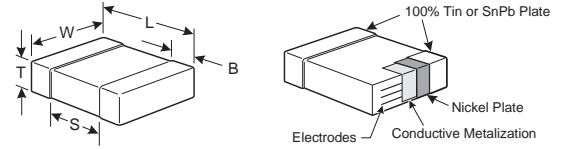

EIA Size Code	Metric Size Code	L Length	W Width	T Thickness	B Bandwidth	S Separation Min.	Mounting Technique
01005	0402	0.40 (.016) ± 0.02 (.001)	0.20 (.008) ± 0.02 (.001)	See Table 2 for Thickness	0.10 (.004) ± 0.03 (.001)	N/A	Solder Reflow Only
0201	0603	0.60 (.024) ± 0.03 (.001)	0.30 (.012) ± 0.03 (.001)		0.15 (.006) ± 0.05 (.002)		
0402	1005	1.00 (.040) ± 0.05 (.002)	0.50 (.020) ± 0.05 (.002)		0.30 (.012) ± 0.10 (.004)	0.30 (.012)	
0603	1608	1.60 (.063) ± 0.15 (.006)	0.80 (.032) ± 0.15 (.006)		0.35 (.014) ± 0.15 (.006)	0.70 (.028)	Solder Wave or Solder Reflow
0805	2012	2.00 (.079) ± 0.20 (.008)	1.25 (.049) ± 0.20 (.008)		0.50 (0.02) ± 0.25 (.010)	0.75 (.030)	
1206	3216	3.20 (.126) ± 0.20 (.008)	1.60 (.063) ± 0.20 (.008)		0.50 (0.02) ± 0.25 (.010)	N/A	Solder Reflow Only
1210	3225	3.20 (.126) ± 0.20 (.008)	2.50 (.098) ± 0.20 (.008)		0.50 (0.02) ± 0.25 (.010)		
1812	4532	4.50 (.177) ± 0.30 (.012)	3.20 (.126) ± 0.30 (.012)		0.60 (.024) ± 0.35 (.014)		
1825	4564	4.50 (.177) ± 0.30 (.012)	6.40 (.252) ± 0.40 (.016)		0.60 (.024) ± 0.35 (.014)		
2220	5650	5.70 (.224) ± 0.40 (.016)	5.00 (.197) ± 0.40 (.016)		0.60 (.024) ± 0.35 (.014)		
2225	5664	5.60 (.220) ± 0.40 (.016)	6.40 (.248) ± 0.40 (.016)		0.60 (.024) ± 0.35 (.014)		

Qualification/Certification

Commercial grade products are subject to internal qualification. Details regarding test methods and conditions are referenced in Table 4, Performance and Reliability.

Environmental Compliance

Pb-Free and RoHS compliant

Electrical Parameters/Characteristics

Item	Parameters/Characteristics
Operating Temperature Range	-55°C to +85°C
Capacitance Change with Reference to +25°C and 0 Vdc Applied (TCC)	±15%
Aging Rate (Max % Cap Loss/Decade Hour)	4.0%
Dielectric Withstanding Voltage	250% of rated voltage (5 ± 1 seconds and charge/discharge not exceeding 50mA)
Dissipation Factor (DF) Maximum Limits @ 25°C	See Dissipation Factor Limit Table
Insulation Resistance (IR) Limit @ 25°C	See Insulation Resistance Limit Table (Rated voltage applied for 120 ± 5 secs @ 25°C)

Regarding Aging Rate: Capacitance measurements (including tolerance) are indexed to a referee time of 48 or 1000 Hours. Please refer to a part number specific datasheet for referee time details.

To obtain IR limit, divide MΩ-μF value by the capacitance and compare to GΩ limit. Select the lower of the two limits.

Capacitance and Dissipation Factor (DF) measured under the following conditions:

1kHz ± 50Hz and 1.0 ± 0.2 Vrms if capacitance ≤ 10μF

120Hz ± 10Hz and 0.5 ± 0.1 Vrms if capacitance > 10μF

Note: When measuring capacitance it is important to ensure the set voltage level is held constant. The HP4284 & Agilent E4980 have a feature known as Automatic Level Control (ALC). The ALC feature should be switched to "ON".

Post Environmental Limits

High Temperature Life, Biased Humidity, Moisture Resistance					
Dielectric	Rated DC Voltage	Capacitance Value	DF (%)	Cap Shift	IR
X5R	>25	All	3.0	± 20%	10% of Initial Limit
	25		7.5		
	<25	< 0.56 μ F	7.5		
	<25	≥ 0.56 μ F	12.0		

Dissipation Factor Limit Table

Rated DC Voltage	Capacitance	Dissipation Factor (Limit)
50V - 200V	All	3%
25V	All	5%
<25V	< 0.56 μ F	5%
<25V	≥ 0.56 μ F	10%

Insulation Resistance Limit Table

EIA Case Size	1000 megohm microfarads or 100G Ω	500 megohm microfarads or 10G Ω
0201	N/A	ALL
0402	< .012 μ F	≥ .012 μ F
0603	< .047 μ F	≥ .047 μ F
0805	< .047 μ F	≥ .047 μ F
1206	< 0.22 μ F	≥ 0.22 μ F
1210	< 0.39 μ F	≥ 0.39 μ F
1808	ALL	N/A
1812	< 2.2 μ F	≥ 2.2 μ F
1825	ALL	N/A
2220	< 10 μ F	≥ 10 μ F
2225	ALL	N/A

Table 1 – X5R Dielectric, (1005 - 1210 Case Sizes)

Cap	Cap Code	Series		C1005			C0201			C0402					C0603					C0805					C1206					C1210										
		Voltage Code		7	9	7	9	4	7	9	8	4	3	5	7	9	8	4	3	5	7	9	8	4	3	5	9	8	4	3	1	9	8	4	3	6	5			
		Voltage DC		4	6.3	4	6.3	16	4	6.3	10	16	25	50	4	6.3	10	16	25	50	4	6.3	10	16	25	50	6.3	10	16	25	50	6.3	10	16	25	35	50			
Cap Tolerance		Product Availability and Chip Thickness Codes - See Table 2 for Chip Thickness Dimensions																																						
10,000 pF	103	K	M			AB	AB	AB																																
12,000 pF	123	K	M						BB	BB	BB	BB																												
15,000 pF	153	K	M						BB	BB	BB	BB																												
18,000 pF	183	K	M						BB	BB	BB	BB																												
22,000 pF	223	K	M	UD	UD				BB	BB	BB	BB																												
27,000 pF	273	K	M						BB	BB	BB	BB																												
33,000 pF	333	K	M						BB	BB	BB	BB																												
39,000 pF	393	K	M						BB	BB	BB	BB																												
47,000 pF	473	K	M						BB	BB	BB	BB																												
56,000 pF	563	K	M						BB	BB	BB	BB																												
68,000 pF	683	K	M						BB	BB	BB	BB																												
82,000 pF	823	K	M						BB	BB	BB	BB																												
0.10 μF	104	K	M			AB	AB		BB	BB	BB	BB	UD																											
0.12 μF	124	K	M																																					
0.15 μF	154	K	M																																					
0.18 μF	184	K	M																																					
0.22 μF	224	K	M						BB	BB																														
0.27 μF	274	K	M											CC	CC	CC	CC												EB	EB	EB	EB								
0.33 μF	334	K	M											CC	CC	CC	CC												EB	EB	EB	EB								
0.39 μF	394	K	M											CC	CC	CC	CC												EB	EB	EB	EB								
0.47 μF	474	K	M											CC	CC	CC	CC	UD	UD	DC	DC	DC	DC	DC					EC	EC	EC	EC				FD	FD	FD	FD	FD
0.56 μF	564	K	M											CC	CC	CC	CC			DD	DD	DD	DD	DD					ED	ED	ED	ED				FD	FD	FD	FD	FD
0.68 μF	684	K	M											CC	CC	CC	CC			DE	DE	DE	DE	DE					EE	EE	EE	EE				FD	FD	FD	FD	FD
0.82 μF	824	K	M											CC	CC	CC	CC			DF	DF	DF	DF	DF					EF	EF	EF	EF				FF	FF	FF	FF	FF
1.0 μF	105	K	M						BB	BB	BB			CC	CC	CC	CC			DG	DG	DG	DG	DG	UD			EE	EE	EE	EH				FH	FH	FH	FH	FH	
1.2 μF	125	K	M																	DC	DC	DC	DC					EC	EC	EC	EC				FD	FD	FD	FD	FD	
1.5 μF	155	K	M																	DC	DC	DC	DC					EC	EC	EC	EC				FD	FD	FD	FD	FD	
1.8 μF	185	K	M																	DD	DD	DD	DD					EC	EC	EC	EC				FD	FD	FD	FD	FD	
2.2 μF	225	K	M						BB ¹	BB ¹				CC	CC	CC	CC			DD	DD	DD					EE	EE	EE	EE	UD				FG	FG	FG	FG	FG	
2.7 μF	275	K	M																	DL	DL	DL	DL					EF	EF	EF	EF				FG	FG	FG	FG	FG	
3.3 μF	335	K	M						BB ¹					CC	CC ¹					DE	DE	DE	DH					EH	EH	EH	EH				FH	FH	FH	FH	FH	
3.9 μF	395	K	M																	DH	DH	DH	DH					EH	EH	EH	EH				FJ	FJ	FJ	FJ		
4.7 μF	475	K	M						BC ²					CC	CC	CC	UD			DG	DG	DH	DG	DG				EH	EH	EH	EH	EH				FK	FK	FK	FK	FK
5.6 μF	565	K	M																	DH	DH	DH						EK	EK	EH				FG	FG	FG	FE	FE		
6.8 μF	685	K	M																	DH	DH	DH						EK	EK	EH				FJ	FJ	FJ	FJ	FJ		
8.2 μF	825	K	M																									ED	ED	EH				FK	FK	FK	FG	FG		
10 μF	106	K	M						UD	UD	UD	UD	UD	CC ¹	CC ¹					DG	DG	DG	DG					EH	EH	EH	EH				FK	FK	FK	FH	FT ¹	
12 μF	126	K	M																																					
15 μF	156	K	M																																					
18 μF	186	K	M																																					
22 μF	226	K	M						UD																				EH	EH										
27 μF	276	K	M																																					
33 μF	336	K	M																																					
39 μF	396	K	M																																					
47 μF	476	K	M										UD							DH ¹	DG							EH ¹	EH ¹							FS ¹	FS	FS ¹		
100 μF	107	K	M																									EH ¹								FS ¹	UD	UD		
Cap	Cap Code	Voltage DC		4	6.3	4	6.3	16	4	6.3	10	16	25	50	4	6.3	10	16	25	50	4	6.3	10	16	25	50	6.3	10	16	25	50	6.3	10	16	25	35	50			
		Voltage Code		7	9	7	9	4	7	9	8	3	5	4	7	9	8	4	3	5	7	9	8	4	3	5	9	8	4	3	5	9	8	4	3	6	5			
		Series		C1005	C0201	C0402					C0603					C0805					C12																			

Surface Mount Multilayer Ceramic Chip Capacitors (SMD MLCCs)

Z5U Dielectric, 50VDC-100VDC (Commercial Grade)

Overview

KEMET's Z5U dielectric features an 85°C maximum operating temperature and is considered "general-purpose." The Electronics Components, Assemblies & Materials Association (EIA) characterizes Z5U dielectric as a Class III material. Components of this classification are fixed, ceramic dielectric capacitors suited for bypass and decoupling or other applications in which dielectric losses, high insulation resistance and capacitance stability are not of major importance. Z5U exhibits a predictable change in

capacitance with respect to time and voltage and displays wide variations in capacitance with reference to ambient temperature. Capacitance change is limited to +22%, -56% from +10°C to +85°C.

Benefits

- +10°C to +85°C operating temperature range
- Pb-Free and RoHS compliant
- EIA 0805, 1206, 1210, 1812, 1825, and 2225 case sizes
- DC voltage ratings of 50V and 100V
- Capacitance offerings ranging from 6,800pF to 2.2µF
- Available capacitance tolerances of ±20% and +80%-20%
- Non-polar device, minimizing installation concerns
- 100% pure matte tin-plated termination finish allowing for excellent solderability

Applications

Typical applications include limited temperature, decoupling and bypass.

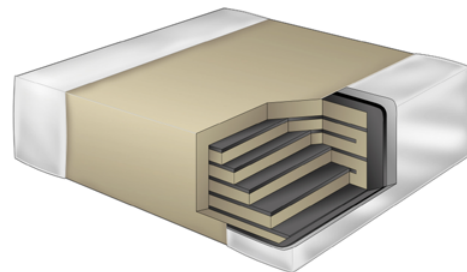

Ordering Information

C	1825	C	225	M	5	U	A	C	TU
Ceramic	Case Size (L" x W")	Specification/ Series	Capacitance Code (pF)	Capacitance Tolerance	Voltage	Dielectric	Failure Rate/ Design	Termination Finish ²	Packaging/Grade (C-Spec) ²
	0805 1206 1210 1812 1825 2225	C = Standard	2 Sig. Digits + Number of Zeros	M = ±20% Z = +80%/-20	5 = 50V 1 = 100V	U = Z5U	A = N/A	C = 100% Matte Sn	Blank = Bulk TU = 7" Reel Unmarked TM = 7" Reel Marked

¹ Additional termination finish options may be available. Contact KEMET for details.

² Additional reeling or packaging options may be available. Contact KEMET for details.

Dimensions – Millimeters (Inches)

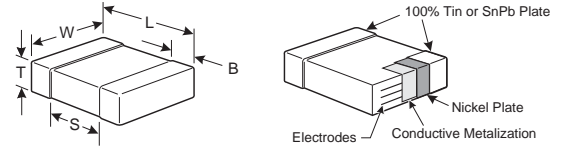

EIA Size Code	Metric Size Code	L Length	W Width	T Thickness	B Bandwidth	S Separation Min.	Mounting Technique
0805	2012	2.00 (.079) ± 0.20 (.008)	1.25 (.049) ± 0.20 (.008)	See Table 2 for Thickness	0.50 (0.02) ± 0.25 (.010)	0.75 (.030)	Solder Wave or Solder Reflow
1206	3216	3.20 (.126) ± 0.20 (.008)	1.60 (.063) ± 0.20 (.008)		0.50 (0.02) ± 0.25 (.010)	N/A	
1210	3225	3.20 (.126) ± 0.20 (.008)	2.50 (.098) ± 0.20 (.008)		0.50 (0.02) ± 0.25 (.010)		
1812	4532	4.50 (.177) ± 0.30 (.012)	3.20 (.126) ± 0.30 (.012)		0.60 (.024) ± 0.35 (.014)		Solder Reflow Only
1825	4564	4.50 (.177) ± 0.30 (.012)	6.40 (.252) ± 0.40 (.016)		0.60 (.024) ± 0.35 (.014)		
2225	5664	5.60 (.220) ± 0.40 (.016)	6.40 (.248) ± 0.40 (.016)		0.60 (.024) ± 0.35 (.014)		

Qualification/Certification

Commercial grade products are subject to internal qualification. Details regarding test methods and conditions are referenced in Table 4, Performance and Reliability.

Environmental Compliance

Pb-Free and RoHS compliant

Electrical Parameters/Characteristics

Item	Parameters/Characteristics
Operating Temperature Range	-10°C to +85°C
Capacitance Change with Reference to +25°C and 0 Vdc Applied (TCC)	+22%, -56%
Aging Rate (Max % Cap Loss/Decade Hour)	7.0%
Dielectric Withstanding Voltage	250% of rated voltage (5 ± 1 seconds and charge/discharge not exceeding 50mA)
Dissipation Factor (DF) Maximum Limits @ 25°C	4.0%
Insulation Resistance (IR) Limit @ 25°C	100 megohm microfarads or 10GΩ (Rated voltage applied for 120 ± 5 secs @ 25°C)

Regarding Aging Rate: Capacitance measurements (including tolerance) are indexed to a referee time of 48 or 1000 Hours. Please refer to a part number specific datasheet for referee time details.

To obtain IR limit, divide MΩ-μF value by the capacitance and compare to GΩ limit. Select the lower of the two limits.

Capacitance and Dissipation Factor (DF) measured under the following conditions:

1kHz ± 50Hz and 1.0 ± 0.2 Vrms if capacitance ≤ 10μF

120Hz ± 10Hz and 0.5 ± 0.1 Vrms if capacitance > 10μF

Note: When measuring capacitance it is important to ensure the set voltage level is held constant. The HP4284 & Agilent E4980 have a feature known as Automatic Level Control (ALC). The ALC feature should be switched to "ON".

Post Environmental Limits

High Temperature Life, Biased Humidity, Moisture Resistance					
Dielectric	Rated DC Voltage	Capacitance Value	DF (%)	Cap Shift	IR
Z5U	>25	All	5.0	± 30%	10% of Initial Limit
	25		7.5		

Table 1 – Z5U Dielectric, (0805 - 2225 Case Sizes)

Cap	Cap Code	Series		C0805		C1206		C1210		C1812		C1825		C2225	
		Voltage Code		5	1	5	1	5	1	5	1	5	1	5	1
		Voltage DC		50	100	50	100	50	100	50	100	50	100	50	100
		Cap Tolerance	Product Availability and Chip Thickness Codes See Table 2 for Chip Thickness Dimensions												
6,800 pF	682	M	Z	DC	DC										
8,200 pF	822	M	Z	DC	DC										
10,000 pF	103	M	Z	DC	DC	EB	EB								
12,000 pF	123	M	Z	DC		EB	EB								
15,000 pF	153	M	Z	DC		EB	EB								
18,000 pF	183	M	Z	DC		EB	EB								
22,000 pF	223	M	Z	DC		EB	EB								
27,000 pF	273	M	Z	DC		EB	EB								
33,000 pF	333	M	Z	DC		EB	EB								
39,000 pF	393	M	Z	DC		EB	EC								
47,000 pF	473	M	Z	DC		EB	EC	FB	FB						
56,000 pF	563	M	Z	DD		EB	EB	FB	FB						
68,000 pF	683	M	Z	DD		EB	EB	FB	FB						
82,000 pF	823	M	Z	DD		EB	EB	FB	FC	GB	GB				
0.10 µF	104	M	Z	DD		EB	EB	FB	FD	GB	GB				
0.12 µF	124	M	Z			EC		FB	FD	GB	GB				
0.15 µF	154	M	Z			EC		FC	FD	GB	GB				
0.18 µF	184	M	Z			EC		FC		GB		HB	HB		
0.22 µF	224	M	Z			EC		FC		GB		HB	HB		
0.27 µF	274	M	Z					FC		GB		HB	HB		
0.33 µF	334	M	Z					FD		GB		HB	HB	KB	KC
0.39 µF	394	M	Z					FD		GB		HB	HB	KB	KC
0.47 µF	474	M	Z					FD		GB		HB		KB	KC
0.56 µF	564	M	Z					FD		GC		HB		KB	
0.68 µF	684	M	Z					FD		GC		HB		KB	
0.82 µF	824	M	Z					FF		GE		HB		KB	
1.0 µF	105	M	Z					FH		GE		HB		KB	
1.2 µF	125	M	Z									HB		KB	
1.5 µF	155	M	Z									HC		KC	
1.8 µF	185	M	Z									HD		KD	
2.2 µF	225	M	Z									HF		KD	
Cap	Cap Code	Voltage DC		50	100	50	100	50	100	50	100	50	100	50	100
		Voltage Code		5	1	5	1	5	1	5	1	5	1	5	1
		Series		C0805		C1206		C1210		C1812		C1825		C2225	

Surface Mount Multilayer Ceramic Chip Capacitors (SMD MLCCs)
Y5V Dielectric, 6.3VDC-50VDC (Commercial Grade)

Overview

KEMET's Y5V dielectric features an 85°C maximum operating temperature and is considered "general-purpose." The Electronics Components, Assemblies & Materials Association (EIA) characterizes Z5U dielectric as a Class III material. Components of this classification are fixed, ceramic dielectric capacitors suited for bypass and decoupling or other applications in which dielectric losses, high insulation resistance and capacitance stability are not of major importance. Y5V exhibits a predictable change in

capacitance with respect to time and voltage and displays wide variations in capacitance with reference to ambient temperature. Capacitance change is limited to +22%, -82% from -30°C to +85°C.

Benefits

- -30°C to +85°C operating temperature range
- Pb-Free and RoHS compliant
- EIA 0402, 0603, 0805, 1206, and 1210 case sizes
- DC voltage ratings of 6.3V, 10V, 16V, 25V and 50V
- Capacitance offerings ranging from .022µF to 22µF
- Available capacitance tolerance of +80%-20%
- Non-polar device, minimizing installation concerns
- 100% pure matte tin-plated termination finish that allowing for excellent solderability

Applications

Typical applications include limited temperature, decoupling and bypass.

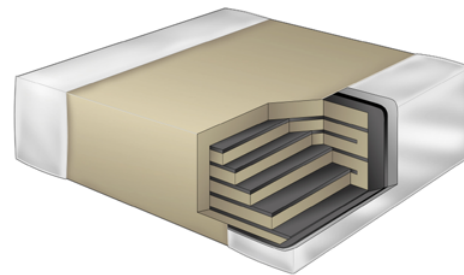

Ordering Information

C	1210	C	226	Z	4	V	A	C	TU
Ceramic	Case Size (L" x W")	Specification/ Series	Capacitance Code (pF)	Capacitance Tolerance	Voltage	Dielectric	Failure Rate/ Design	Termination Finish ²	Packaging/Grade (C-Spec) ²
	0402 0603 0805 1206 1210	C = Standard	2 Sig. Digits + Number of Zeros	Z = +80%/ -20%	9 = 6.3V 8 = 10V 4 = 16V 3 = 25V 5 = 50V	V = Y5V	A = N/A	C = 100% Matte Sn	Blank = Bulk TU = 7" Reel Unmarked TM = 7" Reel Marked

¹ Additional termination finish options may be available. Contact KEMET for details.

² Additional reeling or packaging options may be available. Contact KEMET for details.

Dimensions – Millimeters (Inches)

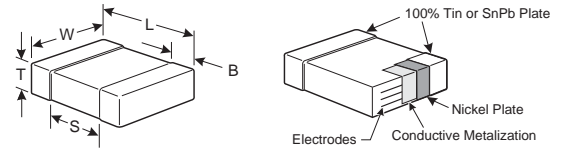

EIA Size Code	Metric Size Code	L Length	W Width	T Thickness	B Bandwidth	S Separation Min.	Mounting Technique
0402	1005	1.00 (.040) ± 0.05 (.002)	0.50 (.020) ± 0.05 (.002)	See Table 2 for Thickness	0.30 (.012) ± 0.10 (.004)	0.30 (.012)	Solder Reflow Only
0603	1608	1.60 (.063) ± 0.15 (.006)	0.80 (.032) ± 0.15 (.006)		0.35 (.014) ± 0.15 (.006)	0.70 (.028)	Solder Wave or Solder Reflow
0805	2012	2.00 (.079) ± 0.20 (.008)	1.25 (.049) ± 0.20 (.008)		0.50 (0.02) ± 0.25 (.010)	0.75 (.030)	
1206	3216	3.20 (.126) ± 0.20 (.008)	1.60 (.063) ± 0.20 (.008)		0.50 (0.02) ± 0.25 (.010)	N/A	Solder Reflow Only
1210	3225	3.20 (.126) ± 0.20 (.008)	2.50 (.098) ± 0.20 (.008)		0.50 (0.02) ± 0.25 (.010)		

Qualification/Certification

Commercial grade products are subject to internal qualification. Details regarding test methods and conditions are referenced in Table 4, Performance and Reliability.

Environmental Compliance

Pb-Free and RoHS compliant

Electrical Parameters/Characteristics

Item	Parameters/Characteristics
Operating Temperature Range	-30°C to +85°C
Capacitance Change with Reference to +25°C and 0 Vdc Applied (TCC)	+22%, -82%
Aging Rate (Max % Cap Loss/Decade Hour)	7.0%
Dielectric Withstanding Voltage	250% of rated voltage (5 ± 1 seconds and charge/discharge not exceeding 50mA)
Dissipation Factor (DF) Maximum Limits @ 25°C	10% (10V), 7% (16V & 25V) and 5% (50V)
Insulation Resistance (IR) Limit @ 25°C	See Insulation Resistance Limit Table (Rated voltage applied for 120 ± 5 secs @ 25°C)

Regarding Aging Rate: Capacitance measurements (including tolerance) are indexed to a referee time of 1000 Hours.

To obtain IR limit, divide $M\Omega \cdot \mu F$ value by the capacitance and compare to $G\Omega$ limit. Select the lower of the two limits.

Capacitance and Dissipation Factor (DF) measured under the following conditions:

1kHz ± 50Hz and 1.0 ± 0.2 Vrms

120Hz ± 10Hz and 0.5 ± 0.1 Vrms if capacitance >10 μF

Note: When measuring capacitance it is important to ensure the set voltage level is held constant. The HP4284 & Agilent E4980 have a feature known as Automatic Level Control (ALC). The ALC feature should be switched to "ON".

Post Environmental Limits

High Temperature Life, Biased Humidity, Moisture Resistance					
Dielectric	Rated DC Voltage	Capacitance Value	DF (%)	Cap Shift	IR
Y5V	>25	All	7.5	± 30%	10% of Initial Limit
	16 / 25		10.0		
	< 16		15.0		

Insulation Resistance Limit Table

EIA Case Size	100 megohm microfarads or 10G Ω	50 megohm microfarads or 10G Ω
All	≥ 16V	≤ 10V

Table 1 – Y5V Dielectric, (0402 - 1210 Case Sizes)

Cap	Cap Code	Series	C0402				C0603				C0805					C1206					C1210							
		Voltage Code	9	8	4		9	8	4	3		9	8	4	3	5		9	8	4	3	5		9	8	4	3	5
		Voltage DC	6.3	10	16		6.3	10	16	25		6.3	10	16	25	50		6.3	10	16	25	50		6.3	10	16	25	50
		Cap Tolerance	Product Availability and Chip Thickness Codes - See Table 2 for Chip Thickness Dimensions																									
22,000 pF	223	Z	BB	BB	BB	CB	CB	CB	CB	DC	DC	DC	DC	DC	EB	EB	EB	EB	EB									
27,000 pF	273	Z	BB	BB	BB	CB	CB	CB	CB	DC	DC	DC	DC	DC	EB	EB	EB	EB	EB									
33,000 pF	333	Z	BB	BB	BB	CB	CB	CB	CB	DC	DC	DC	DC	DC	EB	EB	EB	EB	EB									
39,000 pF	393	Z	BB	BB	BB	CB	CB	CB	CB	DD	DD	DD	DD	DD	EB	EB	EB	EB	EB									
47,000 pF	473	Z	BB	BB	BB	CB	CB	CB	CB	DD	DD	DD	DD	DD	EB	EB	EB	EB	EB									
56,000 pF	563	Z	BB	BB	BB	CB	CB	CB	CB	DD	DD	DD	DD	DD	EB	EB	EB	EB	EB									
68,000 pF	683	Z	BB	BB	BB	CB	CB	CB	CB	DD	DD	DD	DD	DD	EB	EB	EB	EB	EB									
82,000 pF	823	Z	BB	BB	BB	CB	CB	CB	CB	DD	DD	DD	DD	DD	EB	EB	EB	EB	EB									
0.10 µF	104	Z	BB	BB	BB	CB	CB	CB	CB	DD	DD	DD	DD	DD	EB	EB	EB	EB	EB									
0.12 µF	124	Z				CC	CC	CC	CC	DC	DC	DC	DC															
0.15 µF	154	Z				CC	CC	CC	CC	DC	DC	DC	DC															
0.18 µF	184	Z				CC	CC	CC	CC	DC	DC	DC	DC															
0.22 µF	224	Z	BB			CC	CC	CC	CC	DC	DC	DC	DC	DG	EC	EC	EC	EC		FD	FD	FD	FD	FD				
0.27 µF	274	Z				CC	CC	CC	CC	DC	DC	DC	DC		EB	EB	EB	EB		FD	FD	FD	FD	FD				
0.33 µF	334	Z				CC	CC	CC	CC	DC	DC	DC	DC		EB	EB	EB	EB		FD	FD	FD	FD	FD				
0.39 µF	394	Z				CC	CC	CC		DC	DC	DC	DC		EB	EB	EB	EB		FD	FD	FD	FD	FD				
0.47 µF	474	Z	BB			CC	CC	CC	CC	DC	DC	DC	DC		EC	EC	EC	EC		FD	FD	FD	FD	FD				
0.56 µF	564	Z				CC	CC			DD	DD	DD	DD		EB	EB	EB	EB		FD	FD	FD	FD	FD				
0.68 µF	684	Z				CC	CC			DE	DE	DE	DE		EB	EB	EB	EB		FD	FD	FD	FD	FD				
0.82 µF	824	Z				CC	CC			DG	DG	DG	DG		EB	EB	EB	EB		FF	FF	FF	FF	FF				
1.0 µF	105	Z	BB			CC	CC			DG	DG	DG	DG		EG	EG	EG	EG		FH	FH	FH	FH	FH				
1.2 µF	125	Z								DC	DC	DC			EC	EC	EC			FD	FD	FD						
1.5 µF	155	Z								DC	DC	DC			EC	EC	EC			FD	FD	FD						
1.8 µF	185	Z								DD	DD	DD			ED	ED	ED			FD	FD	FD						
2.2 µF	225	Z								DD	DD	DD			EE	EE	EE			FD	FD	FD						
3.3 µF	335	Z								DE	DE	DH			EF	EF	EF			FE	FE	FE						
4.7 µF	475	Z								DH	DH	DH			EM	EM	EM			FG	FG	FG						
5.6 µF	565	Z								DF	DF				EJ	EJ	EJ			FG	FG	FG						
6.8 µF	685	Z								DH	DH				EJ	EJ				FH	FH	FH						
10 µF	106	Z								DH	DH				EJ	EJ				FH	FH	FH						
15 µF	156	Z																		FH	FH	FH						
22 µF	226	Z													EJ					FT	FT	FM						
Cap	Cap Code	Voltage DC	6.3	10	16		6.3	10	16	25		6.3	10	16	25	50		6.3	10	16	25	50		6.3	10	16	25	50
		Voltage Code	9	8	4		9	8	4	3		9	8	4	3	5		9	8	4	3	5		9	8	4	3	5
		Series	C0402				C0603				C0805					C1206					C1210							

Capacitor Array, C0G Dielectric, 10VDC-200VDC (Commercial & Automotive Grade)

Overview

KEMET's Ceramic Chip Capacitor Array in C0G dielectric is an advanced passive technology where multiple capacitor elements are integrated into one common monolithic structure. Array technology promotes reduced placement costs and increased throughput. This is achieved by alternatively placing one device rather than two or four discrete devices. Use of capacitor arrays also saves board space which translates into increased board density and more functions per board. Arrays consume only a portion of the space required for standard chips resulting in savings in inventory and pick/place machine positions.

KEMET's C0G dielectric features a 125°C maximum operating temperature and is considered "stable." The Electronics Components, Assemblies & Materials Association (EIA)

characterizes C0G dielectric as a Class I material. Components of this classification are temperature compensating and are suited for resonant circuit applications or those where Q and stability of capacitance characteristics are required. C0G exhibits no change in capacitance with respect to time and voltage and boasts a negligible change in capacitance with reference to ambient temperature. Capacitance change is limited to $\pm 30\text{ppm}/^\circ\text{C}$ from -55°C to $+125^\circ\text{C}$.

KEMET automotive grade array capacitors meet the demanding Automotive Electronics Council's AEC-Q200 qualification requirements and are manufactured in state of the art ISO/TS 16949:2002 certified facilities.

Benefits

- -55°C to $+125^\circ\text{C}$ operating temperature range
- Saves both circuit board and inventory space
- Reduces placement costs and increases throughput
- RoHS compliant
- EIA 0508 (2-element) and 0612 (4-element) case sizes
- DC voltage ratings of 10V, 16V, 25V, 50V, 100V and 200V
- Capacitance offerings ranging from 10pF to 2200pF
- Available capacitance tolerances of $\pm 5\%$, $\pm 10\%$ and $\pm 20\%$
- Non-polar device, minimizing installation concerns

- Flexible termination option is standard on 0508 case size arrays
- 100% pure matte tin-plated termination finish allowing for excellent solderability
- SnPb termination finish option available upon request (5% min)
- Commercial and Automotive (AEC-Q200) grades available

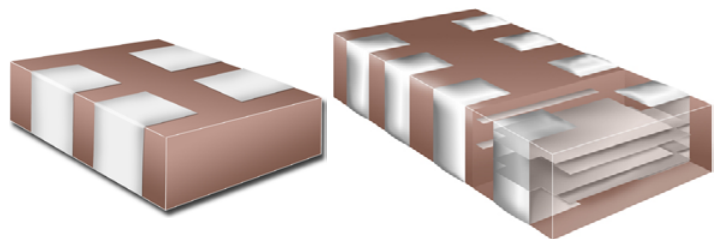

Ordering Information

CA	06	4	C	104	K	4	G	A	C	TU
Ceramic Array	Case Size (L" x W") ¹	Number of Capacitors	Specification/ Series ²	Capacitance Code (pF)	Capacitance Tolerance	Voltage	Dielectric	Failure Rate/ Design	Termination Finish ³	Packaging/Grade (C-Spec) ⁴
	05 = 0508 06 = 0612	2 = 2 4 = 4	C = Standard X = Flexible Termination	2 Sig. Digits + Number of Zeros	J = $\pm 5\%$ K = $\pm 10\%$ M = $\pm 20\%$	8 = 10V 4 = 16V 3 = 25V 5 = 50V 1 = 100V 2 = 200V	G = C0G	A = N/A	C = 100% Matte Sn	Blank = Bulk TU = 7" Reel Unmarked AUTO = Automotive Grade

¹ All previous reference to metric case dimension "1632" has been replaced with an inch standard reference of "0612". Please reference all new designs using the "0612" nomenclature. "CA064" replaces "C1632" in the ordering code.

² 0508 case size is only available with the flexible termination option. "X" must be used in the 6th character position when ordering this case size. 0612 (1632) case size is not currently available with the flexible termination option. "C" must be used in the 6th character position when ordering this case size.

³ Additional termination finish options may be available. Contact KEMET for details.

⁴ Additional reeling or packaging options may be available. Contact KEMET for details.

Dimensions – Millimeters (Inches)

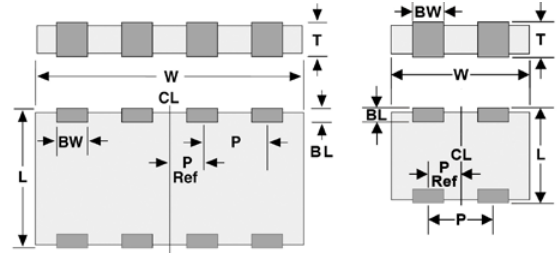

EIA Size Code	Metric Size Code	L Length	W Width	BW Bandwidth	BL Bandlength	T Thickness	P Pitch	P/2 Reference
0508	1220	1.30 (.051) ± 0.15 (.006)	2.10 (.083) ± 0.15 (.006)	0.53 (.021) ± 0.08 (.003)	0.30 (.012) ± 0.20 (.008)	See Table 2 for Thickness	1.00 (.039)	0.50 (.020) ± 0.10 (.004)
0612	1632	1.60 (.063) ± 0.20 (.008)	3.20 (.126) ± 0.20 (.008)	0.40 (0.06) ± 0.20 (.008)	0.30 (.012) ± 0.20 (.008)		0.80 (.031)	0.40 (.031) ± 0.05 (.002)

Applications

Typical applications include those that can benefit from board area savings, cost savings and overall volumetric reduction such as telecommunications, computers, handheld devices and automotive.

Qualification/Certification

Commercial grade products are subject to internal qualification. Details regarding test methods and conditions are referenced in Table 4, Performance and Reliability.

Automotive grade products meet or exceed the requirements outlined by the Automotive Electronics Council. Details regarding test methods and conditions are referenced in document AEC-Q200, Stress Test Qualification for Passive Components. For additional information regarding the Automotive Electronics Council and AEC-Q200, please visit their website @www.aecouncil.com.

Environmental Compliance

RoHS compliant.

Electrical Parameters/Characteristics

Item	Parameters/Characteristics
Operating Temperature Range	-55°C to +125°C
Capacitance Change with Reference to +25°C and 0 Vdc Applied (TCC)	±30PPM/°C
Aging Rate (Max % Cap Loss/Decade Hour)	0%
Dielectric Withstanding Voltage	250% of rated voltage (5 ± 1 seconds and charge/discharge not exceeding 50mA)
Dissipation Factor (DF) Maximum Limit @ 25°C	0.1%
Insulation Resistance (IR) Limit @ 25°C	1000 megohm microfarads or 100GΩ (Rated voltage applied for 120 ± 5 secs @ 25°C)

To obtain IR limit, divide $M\Omega\text{-}\mu F$ value by the capacitance and compare to $G\Omega$ limit. Select the lower of the two limits.

Capacitance and Dissipation Factor (DF) measured under the following conditions:

1MHz ± 100kHz and 1.0Vrms ± 0.2V if capacitance ≤ 1000pF

1kHz ± 50Hz and 1.0Vrms ± 0.2V if capacitance > 1000pF

Note: When measuring capacitance it is important to ensure the set voltage level is held constant. The HP4284 & Agilent E4980 have a feature known as Automatic Level Control (ALC). The ALC feature should be switched to "ON".

Post Environmental Limits

High Temperature Life, Biased Humidity, Moisture Resistance					
Dielectric	Rated DC Voltage	Capacitance Value	DF (%)	Cap Shift	IR
COG	All	All	0.5	0.3% or ± 0.25 pF	10% of Initial Limit

Table 1 – Array, COG Dielectric, (0508 - 0612 Case Sizes)

Cap	Cap Code	Series			CA052 (0508 Case Size)					CA064 (0612 Case Size)					
		Voltage Code			8	4	3	5	1	8	4	3	5	1	2
		Voltage DC			10	16	25	50	100	10	16	25	50	100	200
		Cap Tolerance			Product Availability and Chip Thickness Codes - See Table 2 for Chip Thickness Dimensions										
10 pF	100	J	K	M						MA	MA	MA	MA	MA	MA
12 pF	120	J	K	M						MA	MA	MA	MA	MA	MA
15 pF	150	J	K	M						MA	MA	MA	MA	MA	MA
18 pF	180	J	K	M						MA	MA	MA	MA	MA	MA
22 pF	220	J	K	M						MA	MA	MA	MA	MA	MA
27 pF	270	J	K	M						MA	MA	MA	MA	MA	MA
33 pF	330	J	K	M						MA	MA	MA	MA	MA	MA
39 pF	390	J	K	M						MA	MA	MA	MA	MA	MA
47 pF	470	J	K	M						MA	MA	MA	MA	MA	MA
56 pF	560	J	K	M						MA	MA	MA	MA	MA	MA
68 pF	680	J	K	M						MA	MA	MA	MA	MA	MA
82 pF	820	J	K	M						MA	MA	MA	MA	MA	MA
100 pF	101	J	K	M	PA	PA	PA	PA	PA	MA	MA	MA	MA	MA	MA
120 pF	121	J	K	M	PA	PA	PA	PA	PA	MA	MA	MA	MA	MA	MA
150 pF	151	J	K	M	PA	PA	PA	PA	PA	MA	MA	MA	MA	MA	MA
180 pF	181	J	K	M	PA	PA	PA	PA	PA	MA	MA	MA	MA	MA	MA
220 pF	221	J	K	M	PA	PA	PA	PA	PA	MA	MA	MA	MA	MA	MA
270 pF	271	J	K	M	PA	PA	PA	PA	PA	MA	MA	MA	MA	MA	MA
330 pF	331	J	K	M	PA	PA	PA	PA	PA	MA	MA	MA	MA	MA	MA
390 pF	391	J	K	M	PA	PA	PA	PA	PA	MA	MA	MA	MA	MA	MA
470 pF	471	J	K	M	PA	PA	PA	PA	PA	MA	MA	MA	MA	MA	MA
560 pF	561	J	K	M	PA	PA	PA	PA	PA						
680 pF	681	J	K	M	PA	PA	PA	PA	PA						
820 pF	821	J	K	M	PA	PA	PA	PA	PA						
1,000 pF	102	J	K	M	PA	PA	PA	PA	PA						
1,100 pF	112	J	K	M	PA	PA	PA	PA	PA						
1,200 pF	122	J	K	M	PA	PA	PA	PA	PA						
1,300 pF	132	J	K	M	PA	PA	PA	PA	PA						
1,500 pF	152	J	K	M	PA	PA	PA	PA	PA						
1,600 pF	162	J	K	M	PA	PA	PA	PA	PA						
1,800 pF	182	J	K	M	PA	PA	PA	PA	PA						
2,000 pF	202	J	K	M	PA	PA	PA	PA	PA						
2,200 pF	222	J	K	M	PA	PA	PA	PA	PA						
Cap	Cap Code	Voltage DC			10	16	25	50	100	10	16	25	50	100	200
		Voltage Code			8	4	3	5	1	8	4	3	5	1	2
		Series			CA052 (0508 Case Size)					CA064 (0612 Case Size)					

KEMET reserves the right to substitute product with an improved temperature characteristic, tighter capacitance tolerance and/or higher voltage capability within the same form factor (configuration and dimensions).

These products are protected under US Patents 7,172,985 & 7,670,981, other patents pending, and any foreign counterparts.

Table 2 – Chip Thickness / Packaging Quantities

Thickness Code	Chip Size	Thickness ± Range (mm)	Qty per Reel 7" Plastic	Qty per Reel 13" Plastic	Qty per Reel 7" Paper	Qty per Reel 13" Paper	Qty per Bulk Cassette
PA	0508	0.80 ± 0.10	4000	10000	N/A	N/A	N/A
MA	0612	0.80 ± 0.10	4000	10000	N/A	N/A	N/A

Table 3 – Chip Capacitor Array Land Pattern Design Recommendations per IPC-7351

EIA SIZE CODE	METRIC SIZE CODE	Density Level A: Maximum (Most) Land Protrusion (mm)						Density Level B: Median (Nominal) Land Protrusion (mm)						Density Level C: Minimum (Least) Land Protrusion (mm)					
		C	Y	X	P	V1	V2	C	Y	X	P	V1	V2	C	Y	X	P	V1	V2
0508/CA052	1220	1.60	1.00	0.55	1.00	3.50	3.30	1.50	0.90	0.50	1.00	2.90	2.80	1.40	0.75	0.45	1.00	2.40	2.50
0612/CA064	1632	1.80	1.10	0.50	0.80	3.90	4.40	1.80	0.95	0.50	0.80	3.30	3.90	1.70	0.85	0.40	0.80	2.80	3.60

Density Level A: For low-density Product applications. Provides a wider process window for reflow solder processes. Soldering processes for array type capacitors.

Density Level B: For products with a moderate level of component density. Provides a robust solder attachment condition for reflow solder processes.

Density Level C: For high component density product applications. Before adapting the minimum land pattern variations the user should perform qualification testing based on the conditions outlined in IPC standard 7351 (IPC-7351).

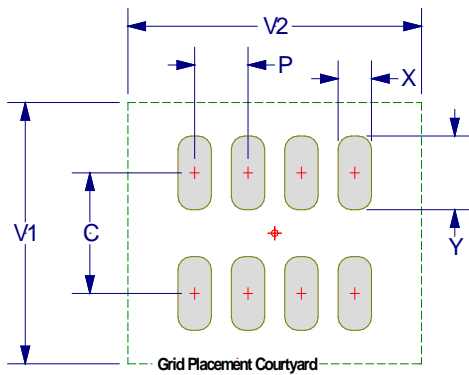

Soldering Process

Recommended Soldering Technique:

- Solder reflow only

Recommended Soldering Profile:

- KEMET recommends following the guidelines outlined in IPC/JEDEC J-STD-020

Table 4 – Performance & Reliability: Test Methods and Conditions

Stress	Reference	Test or Inspection Method
Terminal Strength	JIS-C-6429	Appendix 1, Note: Force of 1.8kg for 60 seconds.
Board Flex	JIS-C-6429	Appendix 2, Note: 2mm (min) for all except 3mm for C0G.
Solderability	J-STD-002	Magnification 50 X. Conditions:
		a) Method B, 4 hours @ 155°C, dry heat @ 235°C
		b) Method B @ 215°C category 3
		c) Method D, category 3 @ 260°C
Temperature Cycling	JESD22 Method JA-104	1000 cycles (-55°C to +125°C), Measurement at 24 hours. +/- 2 hours after test conclusion.
Biased Humidity	MIL-STD-202 Method 103	Load Humidity: 1000 hours 85°C/85%RH and Rated Voltage. Add 100K ohm resistor. Measurement at 24 hours. +/- 2 hours after test conclusion.
		Low Volt Humidity: 1000 hours 85°C/85%RH and 1.5V. Add 100K ohm resistor. Measurement at 24 hours. +/- 2 hours after test conclusion.
Moisture Resistance	MIL-STD-202 Method 106	t = 24 hours/cycle. Steps 7a & 7b not required. Unpowered. Measurement at 24 hours. +/- 2 hours after test conclusion.
Thermal Shock	MIL-STD-202 Method 107	-55°C/+125°C. Note: Number of cycles required-300, maximum transfer time-20 seconds, dwell time-15 minutes. Air-Air.
High Temperature Life	MIL-STD-202 Method 108 / EIA -198	1000 hours at 125°C (85°C for X5R, Z5U and Y5V) with 2 X rated voltage applied.
Storage Life	MIL-STD-202 Method 108	150°C, 0VDC, for 1000 hours.
Mechanical Shock	MIL-STD-202 Method 213	Figure 1 of Method 213, Condition F.
Resistance to Solvents	MIL-STD-202 Method 215	Add aqueous wash chemical - OKEM Clean or equivalent.

Storage and Handling

Ceramic chip capacitors should be stored in normal working environments. While the chips themselves are quite robust in other environments, solderability will be degraded by exposure to high temperatures, high humidity, corrosive atmospheres, and long term storage. In addition, packaging materials will be degraded by high temperature – reels may soften or warp, and tape peel force may increase. KEMET recommends that maximum storage temperature not exceed 40°C, and maximum storage humidity not exceed 70% relative humidity. In addition, temperature fluctuations should be minimized to avoid condensation on the parts, and atmospheres should be free of chlorine and sulfur bearing compounds. For optimized solderability, chip stock should be used promptly, preferably within 1.5 years of receipt.

Capacitor Array, X7R Dielectric, 10VDC-200VDC (Commercial & Automotive Grade)

Overview

KEMET's Ceramic Chip Capacitor Array in X7R dielectric is an advanced passive technology where multiple capacitor elements are integrated into one common monolithic structure. Array technology promotes reduced placement costs and increased throughput. This is achieved by alternatively placing one device rather than two or four discrete devices. Use of capacitor arrays also saves board space which translates into increased board density and more functions per board. Arrays consume only a portion of the space required for standard chips resulting in savings in inventory and pick/place machine positions.

KEMET's X7R dielectric features a 125°C maximum operating temperature and is considered "temperature stable." The Electronics Components, Assemblies & Materials Association (EIA)

characterizes X7R dielectric as a Class II material. Components of this classification are fixed, ceramic dielectric capacitors suited for bypass and decoupling applications or for frequency discriminating circuits where Q and stability of capacitance characteristics are not critical. X7R exhibits a predictable change in capacitance with respect to time and voltage and boasts a minimal change in capacitance with reference to ambient temperature. Capacitance change is limited to $\pm 15\%$ from -55°C to $+125^{\circ}\text{C}$.

KEMET automotive grade array capacitors meet the demanding Automotive Electronics Council's AEC-Q200 qualification requirements and are manufactured in state of the art ISO/TS 16949:2002 certified facilities.

Benefits

- -55°C to $+125^{\circ}\text{C}$ operating temperature range
- Saves both circuit board and inventory space
- Reduces placement costs and increases throughput
- RoHS compliant
- EIA 0508 (2-element) and 0612 (4-element) case sizes
- DC voltage ratings of 10V, 16V, 25V, 50V, 100V and 200V
- Capacitance offerings ranging from 10pF to 2200pF
- Available capacitance tolerances of $\pm 5\%$, $\pm 10\%$ and $\pm 20\%$
- Non-polar device, minimizing installation concerns

- Flexible termination option is standard on 0508 case size arrays
- 100% pure matte tin-plated termination finish allowing for excellent solderability
- SnPb termination finish option available upon request (5% min)
- Commercial and Automotive (AEC-Q200) grades available

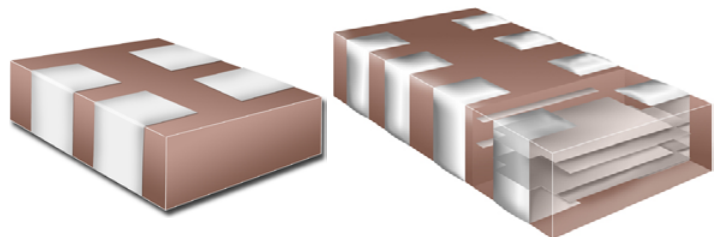

Ordering Information

CA	06	4	C	104	K	4	R	A	C	TU
Ceramic Array	Case Size (L" x W") ¹	Number of Capacitors	Specification/ Series ²	Capacitance Code (pF)	Capacitance Tolerance	Voltage	Dielectric	Failure Rate/ Design	Termination Finish ³	Packaging/Grade (C-Spec) ⁴
	05 = 0508 06 = 0612	2 = 2 4 = 4	C = Standard X = Flexible Termination	2 Sig. Digits + Number of Zeros	J = $\pm 5\%$ K = $\pm 10\%$ M = $\pm 20\%$	8 = 10V 4 = 16V 3 = 25V 5 = 50V 1 = 100V 2 = 200V	R = X7R	A = N/A	C = 100% Matte Sn	Blank = Bulk TU = 7" Reel Unmarked AUTO = Automotive Grade

¹ All previous reference to metric case dimension "1632" has been replaced with an inch standard reference of "0612". Please reference all new designs using the "0612" nomenclature. "CA064" replaces "C1632" in the ordering code.

² 0508 case size is only available with the flexible termination option. "X" must be used in the 6th character position when ordering this case size. 0612 (1632) case size is not currently available with the flexible termination option. "C" must be used in the 6th character position when ordering this case size.

³ Additional termination finish options may be available. Contact KEMET for details.

⁴ Additional reeling or packaging options may be available. Contact KEMET for details.

Dimensions – Millimeters (Inches)

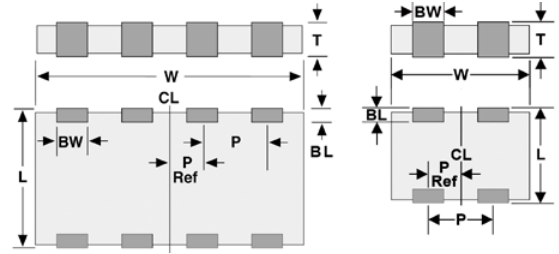

EIA Size Code	Metric Size Code	L Length	W Width	BW Bandwidth	BL Bandlength	T Thickness	P Pitch	P/2 Reference
0508	1220	1.30 (.051) ± 0.15 (.006)	2.10 (.083) ± 0.15 (.006)	0.53 (.021) ± 0.08 (.003)	0.30 (.012) ± 0.20 (.008)	See Table 2 for Thickness	1.00 (.039)	0.50 (.020) ± 0.10 (.004)
0612	1632	1.60 (.063) ± 0.20 (.008)	3.20 (.126) ± 0.20 (.008)	0.40 (0.06) ± 0.20 (.008)	0.30 (.012) ± 0.20 (.008)		0.80 (.031)	0.40 (.031) ± 0.05 (.002)

Applications

Typical applications include those that can benefit from board area savings, cost savings and overall volumetric reduction such as telecommunications, computers, handheld devices and automotive.

Qualification/Certification

Commercial grade products are subject to internal qualification. Details regarding test methods and conditions are referenced in Table 4, Performance and Reliability.

Automotive grade products meet or exceed the requirements outlined by the Automotive Electronics Council. Details regarding test methods and conditions are referenced in document AEC-Q200, Stress Test Qualification for Passive Components. For additional information regarding the Automotive Electronics Council and AEC-Q200, please visit their website @www.aecouncil.com.

Environmental Compliance

RoHS compliant.

Electrical Parameters/Characteristics

Item	Parameters/Characteristics
Operating Temperature Range	-55°C to +125°C
Capacitance Change with Reference to +25°C and 0 Vdc Applied (TCC)	±15%
Aging Rate (Max % Cap Loss/Decade Hour)	3.0%
Dielectric Withstanding Voltage	250% of rated voltage (5 ± 1 seconds and charge/discharge not exceeding 50mA)
Dissipation Factor (DF) Maximum Limits @ 25°C	5%(10V), 3.5%(16V & 25V) and 2.5%(50V to 200V)
Insulation Resistance (IR) Limit @ 25°C	1000 megohm microfarads or 100GΩ (Rated voltage applied for 120 ± 5 secs @ 25°C)

Regarding Aging Rate: Capacitance measurements (including tolerance) are indexed to a referee time of 1000 Hours.

To obtain IR limit, divide MΩ-μF value by the capacitance and compare to GΩ limit. Select the lower of the two limits.

Capacitance and Dissipation Factor (DF) measured under the following conditions:

1kHz ± 50Hz and 1.0 ± 0.2 Vrms if capacitance ≤ 10μF

120Hz ± 10Hz and 0.5 ± 0.1 Vrms if capacitance > 10μF

Note: When measuring capacitance it is important to ensure the set voltage level is held constant. The HP4284 & Agilent E4980 have a feature known as Automatic Level Control (ALC). The ALC feature should be switched to "ON".

Post Environmental Limits

High Temperature Life, Biased Humidity, Moisture Resistance					
Dielectric	Rated DC Voltage	Capacitance Value	DF (%)	Cap Shift	IR
X7R	>25	All	3.0	± 20%	10% of Initial Limit
	16 / 25		5.0		
	< 16		7.5		

Table 1 – Array, X7R Dielectric, (0508 - 0612 Case Sizes)

Cap	Cap Code	Series			CA052 (0508 Case Size)					CA064 (0612 Case Size)					
		Voltage Code			8	4	3	5	1	8	4	3	5	1	2
		Voltage DC			10	16	25	50	100	10	16	25	50	100	200
		Cap Tolerance			Product Availability and Chip Thickness Codes - See Table 2 for Chip Thickness Dimensions										
330 pF	331	J	K	M	PA	PA	PA	PA	PA	MA	MA	MA	MA	MA	MA
390 pF	391	J	K	M	PA	PA	PA	PA	PA	MA	MA	MA	MA	MA	MA
470 pF	471	J	K	M	PA	PA	PA	PA	PA	MA	MA	MA	MA	MA	MA
560 pF	561	J	K	M	PA	PA	PA	PA	PA	MA	MA	MA	MA	MA	MA
680 pF	681	J	K	M	PA	PA	PA	PA	PA	MA	MA	MA	MA	MA	MA
820 pF	821	J	K	M	PA	PA	PA	PA	PA	MA	MA	MA	MA	MA	
1,000 pF	102	J	K	M	PA	PA	PA	PA	PA	MA	MA	MA	MA	MA	
1,200 pF	122	J	K	M	PA	PA	PA	PA	PA	MA	MA	MA	MA	MA	
1,500 pF	152	J	K	M	PA	PA	PA	PA	PA	MA	MA	MA	MA	MA	
1,800 pF	182	J	K	M	PA	PA	PA	PA	PA	MA	MA	MA	MA	MA	
2,200 pF	222	J	K	M	PA	PA	PA	PA	PA	MA	MA	MA	MA	MA	
2,700 pF	272	J	K	M	PA	PA	PA	PA	PA	MA	MA	MA	MA	MA	
3,300 pF	332	J	K	M	PA	PA	PA	PA	PA	MA	MA	MA	MA	MA	
3,900 pF	392	J	K	M	PA	PA	PA	PA	PA	MA	MA	MA	MA	MA	
4,700 pF	472	J	K	M	PA	PA	PA	PA	PA	MA	MA	MA	MA	MA	
5,600 pF	562	J	K	M	PA	PA	PA	PA		MA	MA	MA	MA		
6,800 pF	682	J	K	M	PA	PA	PA	PA		MA	MA	MA	MA		
8,200 pF	822	J	K	M	PA	PA	PA	PA		MA	MA	MA	MA		
10,000 pF	103	J	K	M	PA	PA	PA	PA		MA	MA	MA	MA		
12,000 pF	123	J	K	M	PA	PA	PA	PA		MA	MA	MA	MA		
15,000 pF	153	J	K	M	PA	PA	PA	PA		MA	MA	MA	MA		
18,000 pF	183	J	K	M	PA	PA	PA	PA		MA	MA	MA	MA		
22,000 pF	223	J	K	M	PA	PA	PA	PA		MA	MA	MA	MA		
27,000 pF	273	J	K	M	PA	PA	PA	PA		MA	MA				
33,000 pF	333	J	K	M	PA	PA	PA	PA		MA	MA				
39,000 pF	393	J	K	M	PA	PA	PA	PA		MA	MA				
47,000 pF	473	J	K	M	PA	PA	PA	PA		MA	MA				
56,000 pF	563	J	K	M	PA	PA	PA	PA		MA	MA				
68,000 pF	683	J	K	M	PA	PA	PA	PA		MA	MA				
82,000 pF	823	J	K	M	PA	PA	PA	PA		MA	MA				
0.10 uF	104	J	K	M	PA	PA	PA	PA		MA	MA				
0.15 uF	154	J	K	M	PA										
0.22 uF	224	J	K	M	PA										
Cap	Cap Code	Voltage DC			10	16	25	50	100	10	16	25	50	100	200
		Voltage Code			8	4	3	5	1	8	4	3	5	1	2
		Series			CA052 (0508 Case Size)					CA064 (0612 Case Size)					

Table 2 – Chip Thickness / Packaging Quantities

Thickness Code	Chip Size	Thickness ± Range (mm)	Qty per Reel 7" Plastic	Qty per Reel 13" Plastic	Qty per Reel 7" Paper	Qty per Reel 13" Paper	Qty per Bulk Cassette
PA	0508	0.80 ± 0.10	4000	10000	N/A	N/A	N/A
MA	0612	0.80 ± 0.10	4000	10000	N/A	N/A	N/A

Table 3 – Chip Capacitor Array Land Pattern Design Recommendations per IPC-7351

EIA SIZE CODE	METRIC SIZE CODE	Density Level A: Maximum (Most) Land Protrusion (mm)						Density Level B: Median (Nominal) Land Protrusion (mm)						Density Level C: Minimum (Least) Land Protrusion (mm)					
		C	Y	X	P	V1	V2	C	Y	X	P	V1	V2	C	Y	X	P	V1	V2
0508/CA052	1220	1.60	1.00	0.55	1.00	3.50	3.30	1.50	0.90	0.50	1.00	2.90	2.80	1.40	0.75	0.45	1.00	2.40	2.50
0612/CA064	1632	1.80	1.10	0.50	0.80	3.90	4.40	1.80	0.95	0.50	0.80	3.30	3.90	1.70	0.85	0.40	0.80	2.80	3.60

Density Level A: For low-density Product applications. Provides a wider process window for reflow solder processes. Soldering processes for array type capacitors.

Density Level B: For products with a moderate level of component density. Provides a robust solder attachment condition for reflow solder processes.

Density Level C: For high component density product applications. Before adapting the minimum land pattern variations the user should perform qualification testing based on the conditions outlined in IPC standard 7351 (IPC-7351).

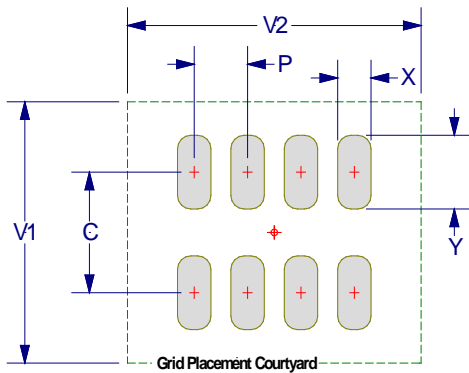

Soldering Process

Recommended Soldering Technique:

- Solder reflow only

Recommended Soldering Profile:

- KEMET recommends following the guidelines outlined in IPC/JEDEC J-STD-020

Table 4 – Performance & Reliability: Test Methods and Conditions

Stress	Reference	Test or Inspection Method
Terminal Strength	JIS-C-6429	Appendix 1, Note: Force of 1.8kg for 60 seconds.
Board Flex	JIS-C-6429	Appendix 2, Note: 2mm (min) for all except 3mm for COG.
Solderability	J-STD-002	Magnification 50 X. Conditions:
		a) Method B, 4 hours @ 155°C, dry heat @ 235°C
		b) Method B @ 215°C category 3
		c) Method D, category 3 @ 260°C
Temperature Cycling	JESD22 Method JA-104	1000 Cycles (-55°C to +125°C), Measurement at 24 hours. +/- 2 hours after test conclusion.
Biased Humidity	MIL-STD-202 Method 103	Load Humidity: 1000 hours 85°C/85%RH and Rated Voltage. Add 100K ohm resistor. Measurement at 24 hours. +/- 2 hours after test conclusion.
		Low Volt Humidity: 1000 hours 85°C/85%RH and 1.5V. Add 100K ohm resistor. Measurement at 24 hours. +/- 2 hours after test conclusion.
Moisture Resistance	MIL-STD-202 Method 106	t = 24 hours/cycle. Steps 7a & 7b not required. Unpowered. Measurement at 24 hours. +/- 2 hours after test conclusion.
Thermal Shock	MIL-STD-202 Method 107	-55°C/+125°C. Note: Number of cycles required-300, Maximum transfer time-20 seconds, Dwell time-15 minutes. Air-Air.
High Temperature Life	MIL-STD-202 Method 108 / EIA -198	1000 hours at 125°C (85°C for X5R, Z5U and Y5V) with 2 X rated voltage applied.
Storage Life	MIL-STD-202 Method 108	150°C, 0VDC, for 1000 Hours.
Mechanical Shock	MIL-STD-202 Method 213	Figure 1 of Method 213, Condition F.
Resistance to Solvents	MIL-STD-202 Method 215	Add aqueous wash chemical - OKEM Clean or equivalent.

Storage and Handling

Ceramic chip capacitors should be stored in normal working environments. While the chips themselves are quite robust in other environments, solderability will be degraded by exposure to high temperatures, high humidity, corrosive atmospheres, and long term storage. In addition, packaging materials will be degraded by high temperature – reels may soften or warp, and tape peel force may increase. KEMET recommends that maximum storage temperature not exceed 40°C, and maximum storage humidity not exceed 70% relative humidity. In addition, temperature fluctuations should be minimized to avoid condensation on the parts, and atmospheres should be free of chlorine and sulfur bearing compounds. For optimized solderability, chip stock should be used promptly, preferably within 1.5 years of receipt.

Commercial Off-the-Shelf (COTS) for Higher Reliability Applications, C0G Dielectric, 10VDC-200VDC

Overview

KEMET's COTS program is an extension of KEMET knowledge of high reliability test regimes and requirements. KEMET regularly supplies "up-screened" products by working with customer drawings and imposing specified design and test requirements. The COTS program offers the same high quality and high reliability components as up-screened products, but at a lower cost to the customer. This is accomplished by eliminating the need for customer-specific drawings to achieve the reliability level required for customer applications. A series of tests and inspections have been selected to provide the accelerated conditioning and 100% screening necessary to eliminate infant mortal failures from the population.

KEMET's C0G dielectric features a 125°C maximum operating temperature and is considered "stable." The Electronics Components, Assemblies & Materials Association (EIA) characterizes C0G dielectric as a Class I material. Components of this classification are temperature compensating and are suited for resonant circuit applications or those where Q and stability of capacitance characteristics are required. C0G exhibits no change in capacitance with respect to time and voltage and boasts a negligible change in capacitance with reference to ambient temperature. Capacitance change is limited to $\pm 30\text{ppm}/^\circ\text{C}$ from -55°C to $+125^\circ\text{C}$.

All COTS testing includes voltage conditioning and post-electrical testing as per MIL-PRF-55681. For enhanced reliability, KEMET also provides the following test level options and conformance certifications:

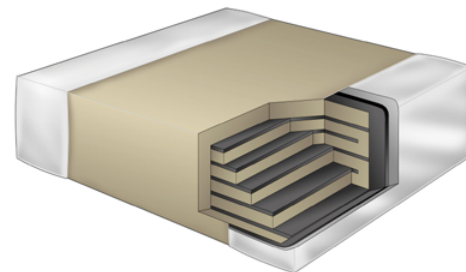
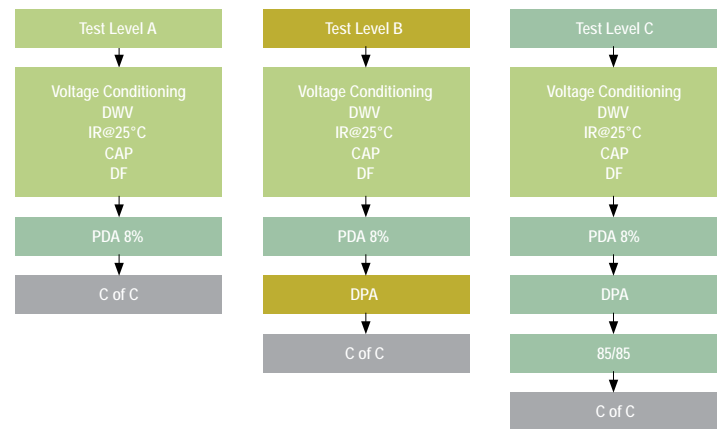

Ordering Information

C	1206	T	104	K	5	G	A	C	TU
Ceramic	Case Size (L" x W")	Specification/ Series	Capacitance Code (pF)	Capacitance Tolerance ¹	Voltage	Dielectric	Failure Rate/Design	Termination Finish ²	Packaging/Grade (C-Spec) ³
	0402 0603 0805 1206 1210 1812 2220	T = COTS	2 Sig. Digits + Number of Zeros Use 9 for 1.0 - 9.9pF Use 8 for 0.5 - .99pF ex. 2.2pF = 229 ex. 0.5pF = 508	C = $\pm 0.25\text{pF}$ D = $\pm 0.5\text{pF}$ F = $\pm 1\%$ G = $\pm 2\%$ J = $\pm 5\%$ K = $\pm 10\%$ M = $\pm 20\%$	8 = 10V 4 = 16V 3 = 25V 6 = 35V 5 = 50V 1 = 100V 2 = 200V	G = C0G	A = Group A Testing per MIL-PRF-55681 PDA 8% B = Group A Testing per MIL-PRF-55681 PDA 8%, DPA per EIA-469 C = Group A Testing per MIL-PRF-55681 PDA 8%, DPA per EIA-469, Humidity per MIL-STD-202, Method 103, Condition A	C = 100% Matte Sn L = SnPb (5% min)	Blank = Bulk TU = 7" Reel Unmarked TM = 7" Reel Marked

¹ Additional capacitance tolerance offerings may be available. Contact KEMET for details.

² Additional termination finish options may be available. Contact KEMET for details.

³ Additional reeling or packaging options may be available. Contact KEMET for details.

Dimensions – Millimeters (Inches)

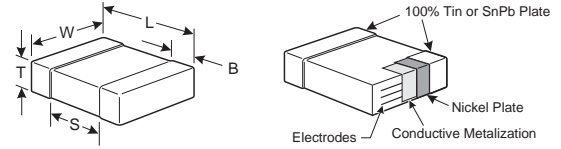

EIA Size Code	Metric Size Code	L Length	W Width	T Thickness	B Bandwidth	S Separation Min.	Mounting Technique
0402	1005	1.00 (.040) ± 0.05 (.002)	0.50 (.020) ± 0.05 (.002)	See Table 2 for Thickness	0.30 (.012) ± 0.10 (.004)	0.30 (.012)	Solder Reflow Only
0603	1608	1.60 (.063) ± 0.15 (.006)	0.80 (.032) ± 0.15 (.006)		0.35 (.014) ± 0.15 (.006)	0.70 (.028)	Solder Wave or Solder Reflow
0805	2012	2.00 (.079) ± 0.20 (.008)	1.25 (.049) ± 0.20 (.008)		0.50 (0.02) ± 0.25 (.010)	0.75 (.030)	
1206	3216	3.20 (.126) ± 0.20 (.008)	1.60 (.063) ± 0.20 (.008)		0.50 (0.02) ± 0.25 (.010)	N/A	Solder Reflow Only
1210	3225	3.20 (.126) ± 0.20 (.008)	2.50 (.098) ± 0.20 (.008)		0.50 (0.02) ± 0.25 (.010)		
1812	4532	4.50 (.177) ± 0.30 (.012)	3.20 (.126) ± 0.30 (.012)		0.60 (.024) ± 0.35 (.014)		
2220	5650	5.70 (.224) ± 0.40 (.016)	5.00 (.197) ± 0.40 (.016)		0.60 (.024) ± 0.35 (.014)		

Benefits

- -55°C to +125°C operating temperature range
- Voltage conditioning and post-electrical testing per MIL-PRF-55681, Paragraph 4.8.3.1, Standard Voltage Conditioning
- Destructive Physical Analysis (DPA) per EIA-469
- Humidity, steady state, low voltage (85/85) per MIL-STD 202, Method 103, Condition A
- Certificate of compliance
- RoHS compliant (excluding SnPb end metallization option)
- EIA 0201, 0402, 0603, 0805, 1206, 1210, 1812, 1825, 2220 and 2225 case sizes
- DC voltage ratings of 10V, 16V, 25V, 50V, 100V and 200V
- Capacitance offerings ranging from 0.5pF up to 0.47µF
- Available capacitance tolerances of ±0.25pF, ±0.5pF, ±1%, ±2%, ±5%, ±10% and ±20%
- No piezoelectric noise
- Extremely low ESR and ESL
- High thermal stability
- High ripple current capability
- Preferred capacitance solution at line frequencies and into the MHz range
- No capacitance change with respect to applied rated DC voltage
- Negligible capacitance change with respect to temperature
- No capacitance decay with time
- Non-polar device, minimizing installation concerns
- SnPb end metallization option available upon request (5% min)

Applications

Typical applications include military, space quality and high reliability electronics.

Qualification/Certification

Commercial grade products are subject to internal qualification. Details regarding test methods and conditions are referenced in Table 4, Performance and Reliability.

Environmental Compliance

RoHS compliant (excluding SnPb termination finish option)

Electrical Parameters/Characteristics

Item	Parameters/Characteristics
Operating Temperature Range	-55°C to +125°C
Capacitance Change with Reference to +25°C and 0 Vdc Applied (TCC)	±30PPM/°C
Aging Rate (Max % Cap Loss/Decade Hour)	0%
Dielectric Withstanding Voltage	250% of rated voltage (5 ± 1 seconds and charge/discharge not exceeding 50mA)
Dissipation Factor (DF) Maximum Limit @ 25°C	0.1%
Insulation Resistance (IR) Limit @ 25°C	1000 megohm microfarads or 100GΩ (Rated voltage applied for 120 ± 5 secs @ 25°C)

To obtain IR limit, divide MΩ-μF value by the capacitance and compare to GΩ limit. Select the lower of the two limits.

Capacitance and Dissipation Factor (DF) measured under the following conditions:

1MHz ± 100kHz and 1.0Vrms ± 0.2V if capacitance ≤1000pF

1kHz ± 50Hz and 1.0Vrms ± 0.2V if capacitance >1000pF

Note: When measuring capacitance it is important to ensure the set voltage level is held constant. The HP4284 & Agilent E4980 have a feature known as Automatic Level Control (ALC). The ALC feature should be switched to "ON".

Post Environmental Limits

High Temperature Life, Biased Humidity, Moisture Resistance					
Dielectric	Rated DC Voltage	Capacitance Value	DF (%)	Cap Shift	IR
C0G	All	All	0.5	0.3% or ± 0.25 pF	10% of Initial Limit

Table 1A – (COTS) COG Dielectric, (0402 - 1206 Case Sizes)

Cap	Cap Code	Series		C0402						C0603						C0805						C1206																					
		Voltage Code		8	4	3	5	1	2	8	4	3	5	1	2	8	4	3	5	1	2	8	4	3	5	1	2																
		Voltage DC		10	16	25	50	100	200	10	16	25	50	100	200	10	16	25	50	100	200	10	16	25	50	100	200																
		Cap Tolerance		Product Availability and Chip Thickness Codes See Table 2 for Chip Thickness Dimensions																																							
0.5-0.75 pF	508-758	C	D																																								
1.0-2.4 pF	109-249	C	D																																								
2.7-5.1 pF	279-519	C	D																																								
5.6-9.1 pF	569-919	C	D																																								
10-13 pF	100-130	C	D																																								
15-24 pF	150-240	C	D																																								
27-36 pF	270-360	C	D																																								
39-51 pF	390-510	D		F	G	J	K	M																																			
56 pF	560	F		G	J	K	M																																				
62 pF	620	F		G	J	K	M																																				
68 pF	680	F		G	J	K	M																																				
75 pF	750	F		G	J	K	M																																				
82 pF	820	F		G	J	K	M																																				
91 pF	910	F		G	J	K	M																																				
100 pF	101	F		G	J	K	M																																				
110 pF	111	F		G	J	K	M																																				
120 pF	121	F		G	J	K	M																																				
130 pF	131	F		G	J	K	M																																				
150 pF	151	F		G	J	K	M																																				
160 pF	161	F		G	J	K	M																																				
180 pF	181	F		G	J	K	M																																				
200 pF	201	F		G	J	K	M																																				
220 pF	221	F		G	J	K	M																																				
240 pF	241	F		G	J	K	M																																				
270 pF	271	F		G	J	K	M																																				
300 pF	301	F		G	J	K	M																																				
330 pF	331	F		G	J	K	M																																				
360 pF	361	F		G	J	K	M																																				
390 pF	391	F		G	J	K	M																																				
430 pF	431	F		G	J	K	M																																				
470 pF	471	F		G	J	K	M																																				
510 pF	511	F		G	J	K	M																																				
560 pF	561	F		G	J	K	M																																				
620 pF	621	F		G	J	K	M																																				
680 pF	681	F		G	J	K	M																																				
750 pF	751	F		G	J	K	M																																				
820 pF	821	F		G	J	K	M																																				
910 pF	911	F		G	J	K	M																																				
1,000 pF	102	F		G	J	K	M																																				
1,100 pF	112	F		G	J	K	M																																				
1,200 pF	122	F		G	J	K	M																																				
1,300 pF	132	F		G	J	K	M																																				
1,500 pF	152	F		G	J	K	M																																				
1,600 pF	162	F		G	J	K	M																																				
1,800 pF	182	F		G	J	K	M																																				
2,000 pF	202	F		G	J	K	M																																				
2,200 pF	222	F		G	J	K	M																																				
2,400 pF	242	F		G	J	K	M																																				
2,700 pF	272	F		G	J	K	M																																				
3,000 pF	302	F		G	J	K	M																																				
3,300 pF	332	F		G	J	K	M																																				
3,600 pF	362	F		G	J	K	M																																				
3,900 pF	392	F		G	J	K	M																																				
4,300 pF	432	F		G	J	K	M																																				
4,700 pF	472	F		G	J	K	M																																				
Cap	Cap Code	Voltage DC		10	16	25	50	100	200	Voltage Code		8	4	3	5	1	2	Series		C0402						C0603						C0805						C1206					

KEMET reserves the right to substitute product with an improved temperature characteristic, tighter capacitance tolerance and/or higher voltage capability within the same form factor (configuration and dimensions).

These products are protected under US Patents 7,172,985 & 7,670,981, other patents pending, and any foreign counterparts.

Table 1A – (COTS) C0G Dielectric, (0402 - 1206 Case Sizes) con't

Cap	Cap Code	Series	C0402						C0603						C0805						C1206							
		Voltage Code	8	4	3	5	1	2	8	4	3	5	1	2	8	4	3	5	1	2	8	4	3	5	1	2		
		Voltage DC	10	16	25	50	100	200	10	16	25	50	100	200	10	16	25	50	100	200	10	16	25	50	100	200		
		Cap Tolerance	Product Availability and Chip Thickness Codes See Table 2 for Chip Thickness Dimensions																									
5,100 pF	512	F G J K M							CB	CB	CB	CB				DE	DE	DE	DE	DC			ED	ED	ED	ED	ED	
5,600 pF	562	F G J K M							CB	CB	CB	CB				DC	DC	DC	DC	DC			ED	ED	ED	ED	ED	
6,200 pF	622	F G J K M							CB	CB	CB	CB				DC	DC	DC	DC	DC			EB	EB	EB	EB	EB	
6,800 pF	682	F G J K M							CB	CB	CB	CB				DC	DC	DC	DC	DC			EB	EB	EB	EB	EB	
7,500 pF	752	F G J K M							CB	CB	CB	CB				DC	DC	DC	DC	DC			EB	EB	EB	EB	EB	
8,200 pF	822	F G J K M							CB	CB	CB					DC	DC	DC	DC	DC			EC	EC	EC	EC	EC	EB
9,100 pF	912	F G J K M							CB	CB	CB					DC	DC	DC	DC	DC			EC	EC	EC	EC	EC	EB
10,000 pF	103	F G J K M							CB	CB	CB					DC	DC	DC	DC	DC	DD		ED	ED	ED	ED	ED	EB
12,000 pF	123	F G J K M							CB	CB	CB					DC	DC	DC	DC	DC	DE		ED	ED	ED	ED	ED	EB
15,000 pF	153	F G J K M							CB	CB	CB					DC	DC	DC	DC	DC	DG		EB	EB	EB	EB	EB	EB
18,000 pF	183	F G J K M														DC	DC	DC	DC	DD			EB	EB	EB	EB	EB	EB
22,000 pF	223	F G J K M														DD	DD	DD	DF				EB	EB	EB	EB	EB	EC
27,000 pF	273	F G J K M														DF	DF	DF					EB	EB	EB	EB	EB	EE
33,000 pF	333	F G J K M														DG	DG	DG					EB	EB	EB	EB	EB	EE
47,000 pF	473	F G J K M														DG	DG	DG					EC	EC	EC	EE	EH	
56,000 pF	563	F G J K M																					ED	ED	ED	EF		
68,000 pF	683	F G J K M																					EF	EF	EF	EH		
82,000 pF	823	F G J K M																					EH	EH	EH	EH		
0.10 µF	104	F G J K M																					EH	EH	EH			
Cap	Cap Code	Voltage DC	10	16	25	50	100	200	10	16	25	50	100	200	10	16	25	50	100	200	10	16	25	50	100	200		
		Voltage Code	8	4	3	5	1	2	8	4	3	5	1	2	8	4	3	5	1	2	8	4	3	5	1	2		
		Series	C0402						C0603						C0805						C1206							

Table 1B – (1210 - 2220 Case Sizes)

Cap	Cap Code	Series	C1210						C1812			C2220								
		Voltage Code	8	4	3	5	1	2	5	1	2	3	1	2						
		Voltage DC	10	16	25	50	100	200	50	100	200	50	100	200						
		Cap Tolerance	Product Availability and Chip Thickness Codes See Table 2 for Chip Thickness Dimensions																	
0.5-0.75 pF	508-758	C D																		
1.0-2.4 pF	109-249	C D							FB	FB	FB	FB	FB	FB						
2.7-5.1 pF	279-519	C D			K	M			FB	FB	FB	FB	FB	FB						
5.6-9.1 pF	569-919	C D			J	K	M		FB	FB	FB	FB	FB	FB						
10-13 pF	100-130	C D			J	K	M		FB	FB	FB	FB	FB	FB						
15-24 pF	150-240	C D	G	J	K	M			FB	FB	FB	FB	FB	FB						
27-36 pF	270-360	D	G	J	K	M			FB	FB	FB	FB	FB	FB						
39-51 pF	390-510	D	F	G	J	K	M		FB	FB	FB	FB	FB	FB						
56-82 pF	560-820		F	G	J	K	M		FB	FB	FB	FB	FB	FB						
91-180 pF	910-181		F	G	J	K	M		FB	FB	FB	FB	FB	FB						
200-360 pF	201-361		F	G	J	K	M		FB	FB	FB	FB	FB	FB						
390 pF	391		F	G	J	K	M		FB	FB	FB	FB	FB	FB						
430 pF	431		F	G	J	K	M		FB	FB	FB	FB	FB	FB						
470 pF	471		F	G	J	K	M		FB	FB	FB	FB	FB	FB	GB	GB	GB			
510 pF	511		F	G	J	K	M		FB	FB	FB	FB	FB	FB	GB	GB	GB			
560 pF	561		F	G	J	K	M		FB	FB	FB	FB	FB	FB	GB	GB	GB			
620 pF	621		F	G	J	K	M		FB	FB	FB	FB	FB	FB	GB	GB	GB			
680 pF	681		F	G	J	K	M		FB	FB	FB	FB	FB	FB	GB	GB	GB			
750 pF	751		F	G	J	K	M		FB	FB	FB	FB	FB	FB	GB	GB	GB			
Cap	Cap Code	Voltage DC	10	16	25	50	100	200	50	100	200	50	100	200						
		Voltage Code	8	4	3	5	1	2	5	1	2	3	1	2						
		Series	C1210						C1812			C2220								

KEMET reserves the right to substitute product with an improved temperature characteristic, tighter capacitance tolerance and/or higher voltage capability within the same form factor (configuration and dimensions).

These products are protected under US Patents 7,172,985 & 7,670,981, other patents pending, and any foreign counterparts.

Table 1B – (COTS) C0G Dielectric, (1210 - 2220 Case Sizes) con't

Cap	Cap Code	Series					C1210						C1812			C2220		
		Voltage Code					8	4	3	5	1	2	5	1	2	3	1	2
		Voltage DC					10	16	25	50	100	200	50	100	200	50	100	200
		Cap Tolerance					Product Availability and Chip Thickness Codes See Table 2 for Chip Thickness Dimensions											
820 pF	821	F	G	J	K	M	FB	FB	FB	FB	FB	FB	GB	GB	GB			
910 pF	911	F	G	J	K	M	FB	FB	FB	FB	FB	FB	GB	GB	GB			
1,000 pF	102	F	G	J	K	M	FB	FB	FB	FB	FB	FB	GB	GB	GB			
1,100 pF	112	F	G	J	K	M	FB	FB	FB	FB	FB	FB	GB	GB	GB			
1,200 pF	122	F	G	J	K	M	FB	FB	FB	FB	FB	FB	GB	GB	GB			
1,300 pF	132	F	G	J	K	M	FB	FB	FB	FB	FB	FC	GB	GB	GB			
1,500 pF	152	F	G	J	K	M	FB	FB	FB	FB	FB	FE	GB	GB	GB			
1,600 pF	162	F	G	J	K	M	FB	FB	FB	FB	FB	FE	GB	GB	GB			
1,800 pF	182	F	G	J	K	M	FB	FB	FB	FB	FB	FE	GB	GB	GB			
2,000 pF	202	F	G	J	K	M	FB	FB	FB	FB	FC	FE	GB	GB	GB			
2,200 pF	222	F	G	J	K	M	FB	FB	FB	FB	FC	FG	GB	GB	GB			
2,400 pF	242	F	G	J	K	M	FB	FB	FB	FB	FC	FC						
2,700 pF	272	F	G	J	K	M	FB	FB	FB	FB	FC	FC	GB	GB	GB			
3,000 pF	302	F	G	J	K	M	FB	FB	FB	FB	FC	FF						
3,300 pF	332	F	G	J	K	M	FB	FB	FB	FB	FF	FF	GB	GB	GB			
3,600 pF	362	F	G	J	K	M	FB	FB	FB	FB	FF	FF						
3,900 pF	392	F	G	J	K	M	FB	FB	FB	FB	FF	FF	GB	GB	GB			
4,300 pF	432	F	G	J	K	M	FB	FB	FB	FB	FF	FG						
4,700 pF	472	F	G	J	K	M	FF	FF	FF	FF	FG	FG	GB	GB	GD			
5,100 pF	512	F	G	J	K	M	FB	FB	FB	FB	FG	FG						
5,600 pF	562	F	G	J	K	M	FB	FB	FB	FB	FG	FG	GB	GB	GH			
6,200 pF	622	F	G	J	K	M	FB	FB	FB	FB	FG	FG						
6,800 pF	682	F	G	J	K	M	FB	FB	FB	FB	FG	FG	GB	GB	GJ	JB	JB	
7,500 pF	752	F	G	J	K	M	FC	FC	FC	FC	FC	FC						
8,200 pF	822	F	G	J	K	M	FC	FC	FC	FC	FC	FC	GB	GH		JB	JB	
9,100 pF	912	F	G	J	K	M	FE	FE	FE	FE	FE	FE						
10,000 pF	103	F	G	J	K	M	FF	FF	FF	FF	FF	FF	GB	GH		JB	JB	
12,000 pF	123	F	G	J	K	M	FG	FG	FG	FG	FB	FB	GB	GG		JB	JB	
15,000 pF	153	F	G	J	K	M	FG	FG	FG	FG	FB	FB	GB	GB		JB	JB	
18,000 pF	183	F	G	J	K	M	FB	FB	FB	FB	FB	FB	GB	GB		JB	JB	
22,000 pF	223	F	G	J	K	M	FB	FB	FB	FB	FB	FB	GB	GB		JB	JB	
27,000 pF	273	F	G	J	K	M	FB	FB	FB	FB	FB	FB	GB	GB		JB	JB	
33,000 pF	333	F	G	J	K	M	FB	FB	FB	FB	FB	FB	GB	GB		JB	JB	
47,000 pF	473	F	G	J	K	M	FB	FB	FB	FB	FE	FE	GB	GB		JB	JB	
56,000 pF	563	F	G	J	K	M	FB	FB	FB	FB	FF	FF	GB	GB		JB	JB	
68,000 pF	683	F	G	J	K	M	FB	FB	FB	FC	FG	FG	GB	GB		JB	JB	
82,000 pF	823	F	G	J	K	M	FC	FC	FC	FF	FH	FH	GB	GB		JB	JB	
0.10 μF	104	F	G	J	K	M	FE	FE	FE	FG	FM	FM	GB	GD		JB	JB	
0.12 μF	124	F	G	J	K	M	FG	FG	FG	FH	FH	FH	GB	GH		JB	JB	
0.15 μF	154	F	G	J	K	M	FH	FH	FH	FM	FM	FM	GD	GN		JB	JB	
0.18 μF	184	F	G	J	K	M	FJ	FJ	FJ				GH			JB	JD	
0.22 μF	224	F	G	J	K	M	FK	FK	FK				GK			JB	JD	
0.27 μF	274	F	G	J	K	M										JB	JF	
0.33 μF	334	F	G	J	K	M										JD	JG	
0.47 μF	474	F	G	J	K	M										JG		
Cap	Cap Code	Voltage DC					10	16	25	50	100	200	50	100	200	50	100	200
		Voltage Code					8	4	3	5	1	2	5	1	2	3	1	2
		Series					C1210						C1812			C2220		

KEMET reserves the right to substitute product with an improved temperature characteristic, tighter capacitance tolerance and/or higher voltage capability within the same form factor (configuration and dimensions).

These products are protected under US Patents 7,172,985 & 7,670,981, other patents pending, and any foreign counterparts.

Commercial Off-the-Shelf (COTS) for Higher Reliability Applications, X7R Dielectric, 6.3VDC-200VDC

Overview

KEMET's COTS program is an extension of KEMET knowledge of high reliability test regimes and requirements. KEMET regularly supplies "up-screened" products by working with customer drawings and imposing specified design and test requirements. The COTS program offers the same high quality and high reliability components as up-screened products, but at a lower cost to the customer. This is accomplished by eliminating the need for customer-specific drawings to achieve the reliability level required for customer applications. A series of tests and inspections have been selected to provide the accelerated conditioning and 100% screening necessary to eliminate infant mortal failures from the population.

KEMET's X7R dielectric features a 125°C maximum operating temperature and is considered "temperature stable." The Electronics Components, Assemblies & Materials Association (EIA) characterizes X7R dielectric as a Class II material. Components of this classification are fixed, ceramic dielectric capacitors suited for bypass and decoupling applications or for frequency discriminating circuits where Q and stability of capacitance characteristics are not critical. X7R exhibits a predictable change in capacitance with respect to time and voltage and boasts a minimal change in capacitance with reference to ambient temperature. Capacitance change is limited to ±15% from -55°C to +125°C.

All COTS testing includes voltage conditioning and post-electrical testing as per MIL-PRF-55681. For enhanced reliability, KEMET also provides the following test level options and conformance certifications:

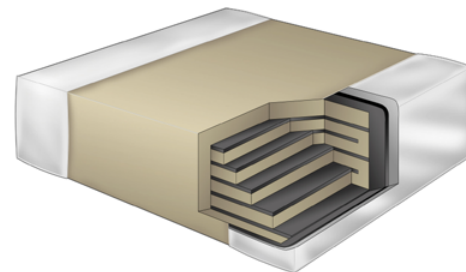
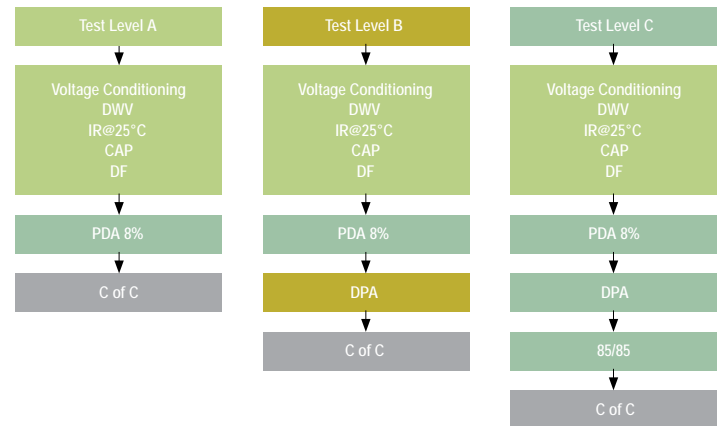

Ordering Information

C	1210	T	104	K	5	R	A	C	TU
Ceramic	Case Size (L" x W")	Specification/ Series	Capacitance Code (pF)	Capacitance Tolerance	Voltage	Dielectric	Failure Rate/Design	Termination Finish ¹	Packaging/Grade (C-Spec) ²
	0402 0603 0805 1206 1210 1812 2220	T = COTS	2 Sig. Digits + Number of Zeros	J = ±5% K = ±10% M = ±20%	9 = 6.3V 8 = 10V 4 = 16V 3 = 25V 5 = 50V 1 = 100V 2 = 200V	R = X7R	A = Group A Testing per MIL-PRF-55681 PDA 8% B = Group A Testing per MIL-PRF-55681 PDA 8%, DPA per EIA-469 C = Group A Testing per MIL-PRF-55681 PDA 8%, DPA per EIA-469, Humidity per MIL-STD-202, Method 103, Condition A	C = 100% Matte Sn L = SnPb (5% min)	Blank = Bulk TU = 7" Reel Unmarked TM = 7" Reel Marked

¹ Additional termination finish options may be available. Contact KEMET for details.

² Additional reeling or packaging options may be available. Contact KEMET for details.

Dimensions – Millimeters (Inches)

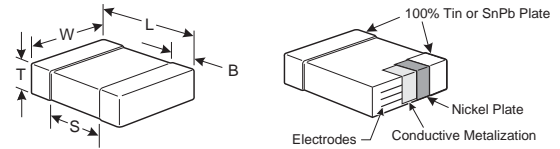

EIA Size Code	Metric Size Code	L Length	W Width	T Thickness	B Bandwidth	S Separation Min.	Mounting Technique
0402	1005	1.00 (.040) ± 0.05 (.002)	0.50 (.020) ± 0.05 (.002)	See Table 2 for Thickness	0.30 (.012) ± 0.10 (.004)	0.30 (.012)	Solder Reflow Only
0603	1608	1.60 (.063) ± 0.15 (.006)	0.80 (.032) ± 0.15 (.006)		0.35 (.014) ± 0.15 (.006)	0.70 (.028)	Solder Wave or Solder Reflow
0805	2012	2.00 (.079) ± 0.20 (.008)	1.25 (.049) ± 0.20 (.008)		0.50 (0.02) ± 0.25 (.010)	0.75 (.030)	
1206	3216	3.20 (.126) ± 0.20 (.008)	1.60 (.063) ± 0.20 (.008)		0.50 (0.02) ± 0.25 (.010)	N/A	Solder Reflow Only
1210	3225	3.20 (.126) ± 0.20 (.008)	2.50 (.098) ± 0.20 (.008)		0.50 (0.02) ± 0.25 (.010)		
1812	4532	4.50 (.177) ± 0.30 (.012)	3.20 (.126) ± 0.30 (.012)		0.60 (.024) ± 0.35 (.014)		
2220	5650	5.70 (.224) ± 0.40 (.016)	5.00 (.197) ± 0.40 (.016)		0.60 (.024) ± 0.35 (.014)		

Benefits

- -55°C to +125°C operating temperature range
- Voltage conditioning and post-electrical testing per MIL-PRF-55681, Paragraph 4.8.3.1, Standard Voltage Conditioning
- Destructive Physical Analysis (DPA) per EIA-469
- Humidity, steady state, low voltage (85/85) per MIL-STD 202, Method 103, Condition A
- Certificate of compliance
- Pb-Free and RoHS compliant (excluding SnPb end metallization option)
- Temperature stable dielectric
- EIA 0402, 0603, 0805, 1206, 1210, 1812, and 2220 case sizes
- DC voltage ratings of 6.3V, 10V, 16V, 25V, 50V, 100V and 200V
- Capacitance offerings ranging from 150pF to 22µF
- Available capacitance tolerances of ±5%, ±10% & ±20%
- Non-polar device, minimizing installation concerns
- SnPb end metallization option available upon request (5% min)

Applications

Typical applications include military, space quality and high reliability electronics.

Qualification/Certification

Commercial grade products are subject to internal qualification. Details regarding test methods and conditions are referenced in Table 4, Performance and Reliability.

Environmental Compliance

Pb-Free and RoHS compliant (excluding SnPb termination finish option)

Electrical Parameters/Characteristics

Item	Parameters/Characteristics
Operating Temperature Range	-55°C to +125°C
Capacitance Change with Reference to +25°C and 0 Vdc Applied (TCC)	±15%
Aging Rate (Max % Cap Loss/Decade Hour)	3.0%
Dielectric Withstanding Voltage	250% of rated voltage (5 ± 1 seconds and charge/discharge not exceeding 50mA)
Dissipation Factor (DF) Maximum Limits @ 25°C	5%(10V), 3.5%(16V & 25V) and 2.5%(50V to 250V)
Insulation Resistance (IR) Limit @ 25°C	See Insulation Resistance Limit Table (Rated voltage applied for 120 ± 5 secs @ 25°C)

Regarding Aging Rate: Capacitance measurements (including tolerance) are indexed to a referee time of 1000 Hours.

To obtain IR limit, divide $M\Omega\text{-}\mu\text{F}$ value by the capacitance and compare to $G\Omega$ limit. Select the lower of the two limits.

Capacitance and Dissipation Factor (DF) measured under the following conditions:

1kHz ± 50Hz and 1.0 ± 0.2 Vrms if capacitance ≤ 10μF

120Hz ± 10Hz and 0.5 ± 0.1 Vrms if capacitance > 10μF

Note: When measuring capacitance it is important to ensure the set voltage level is held constant. The HP4284 & Agilent E4980 have a feature known as Automatic Level Control (ALC). The ALC feature should be switched to "ON".

Post Environmental Limits

High Temperature Life, Biased Humidity, Moisture Resistance					
Dielectric	Rated DC Voltage	Capacitance Value	DF (%)	Cap Shift	IR
X7R	>25	All	3.0	± 20%	10% of Initial Limit
	16 / 25		5.0		
	< 16		7.5		

Insulation Resistance Limit Table

EIA Case Size	1000 megohm microfarads or 100GΩ	500 megohm microfarads or 10GΩ
0201	N/A	ALL
0402	< .012μF	≥ .012μF
0603	< .047μF	≥ .047μF
0805	< .047μF	≥ .047μF
1206	< 0.22μF	≥ 0.22μF
1210	< 0.39μF	≥ 0.39μF
1808	ALL	N/A
1812	< 2.2μF	≥ 2.2μF
1825	ALL	N/A
2220	< 10μF	≥ 10μF
2225	ALL	N/A

Table 1A – (COTS) X7R Dielectric, (0402 - 1206 Case Sizes)

Cap	Cap Code	Series			C0402					C0603						C0805						C1206								
		Voltage Code			9	8	4	3	5	9	8	4	3	5	1	2	9	8	4	3	5	1	2	9	8	4	3	5	1	2
		Voltage DC			6.3	10	16	25	50	6.3	10	16	25	50	100	200	6.3	10	16	25	50	100	200	6.3	10	16	25	50	100	200
		Cap Tolerance			Product Availability and Chip Thickness Codes - See Table 2 for Chip Thickness Dimensions																									
150 pF	151	J	K	M	BB	BB	BB	BB	BB	CB	CB	CB	CB	CB	CB	DC	DC	DC	DC	DC	DC	DC								
180 pF	181	J	K	M	BB	BB	BB	BB	BB	CB	CB	CB	CB	CB	CB	DC	DC	DC	DC	DC	DC	DC								
220 pF	221	J	K	M	BB	BB	BB	BB	BB	CB	CB	CB	CB	CB	CB	DC	DC	DC	DC	DC	DC	DC								
270 pF	271	J	K	M	BB	BB	BB	BB	BB	CB	CB	CB	CB	CB	CB	DC	DC	DC	DC	DC	DC	DC								
330 pF	331	J	K	M	BB	BB	BB	BB	BB	CB	CB	CB	CB	CB	CB	DC	DC	DC	DC	DC	DC	DC								
390 pF	391	J	K	M	BB	BB	BB	BB	BB	CB	CB	CB	CB	CB	CB	DC	DC	DC	DC	DC	DC	DC								
470 pF	471	J	K	M	BB	BB	BB	BB	BB	CB	CB	CB	CB	CB	CB	DC	DC	DC	DC	DC	DC	DC								
560 pF	561	J	K	M	BB	BB	BB	BB	BB	CB	CB	CB	CB	CB	CB	DC	DC	DC	DC	DC	DC	DC								
680 pF	681	J	K	M	BB	BB	BB	BB	BB	CB	CB	CB	CB	CB	CB	DC	DC	DC	DC	DC	DC	DC								
820 pF	821	J	K	M	BB	BB	BB	BB	BB	CB	CB	CB	CB	CB	CB	DC	DC	DC	DC	DC	DC	DC								
1,000 pF	102	J	K	M	BB	BB	BB	BB	BB	CB	CB	CB	CB	CB	CB	DC	DC	DC	DC	DC	DC	DC	EB	EB	EB	EB	EB	EB		
1,200 pF	122	J	K	M	BB	BB	BB	BB	BB	CB	CB	CB	CB	CB	CB	DC	DC	DC	DC	DC	DC	DC	EB	EB	EB	EB	EB	EB		
1,500 pF	152	J	K	M	BB	BB	BB	BB	BB	CB	CB	CB	CB	CB	CB	DC	DC	DC	DC	DC	DC	DC	EB	EB	EB	EB	EB	EB		
1,800 pF	182	J	K	M	BB	BB	BB	BB	BB	CB	CB	CB	CB	CB	CB	DC	DC	DC	DC	DC	DC	DC	EB	EB	EB	EB	EB	EB		
2,200 pF	222	J	K	M	BB	BB	BB	BB	BB	CB	CB	CB	CB	CB	CB	DC	DC	DC	DC	DC	DC	DC	EB	EB	EB	EB	EB	EB		
2,700 pF	272	J	K	M	BB	BB	BB	BB	BB	CB	CB	CB	CB	CB	CB	DC	DC	DC	DC	DC	DC	DC	EB	EB	EB	EB	EB	EB		
3,300 pF	332	J	K	M	BB	BB	BB	BB	BB	CB	CB	CB	CB	CB	CB	DC	DC	DC	DC	DC	DC	DC	EB	EB	EB	EB	EB	EB		
3,900 pF	392	J	K	M	BB	BB	BB	BB	BB	CB	CB	CB	CB	CB	CB	DC	DC	DC	DC	DC	DC	DC	EB	EB	EB	EB	EB	EB		
4,700 pF	472	J	K	M	BB	BB	BB	BB	BB	CB	CB	CB	CB	CB	CB	DC	DC	DC	DC	DC	DC	DC	EB	EB	EB	EB	EB	EB		
5,600 pF	562	J	K	M	BB	BB	BB	BB	BB	CB	CB	CB	CB	CB	CB	DC	DC	DC	DC	DC	DC	DC	EB	EB	EB	EB	EB	EB		
6,800 pF	682	J	K	M	BB	BB	BB	BB	BB	CB	CB	CB	CB	CB	CB	DC	DC	DC	DC	DC	DC	DC	EB	EB	EB	EB	EB	EB		
8,200 pF	822	J	K	M	BB	BB	BB	BB	BB	CB	CB	CB	CB	CB	CB	DC	DC	DC	DC	DC	DC	DC	EB	EB	EB	EB	EB	EB		
10,000 pF	103	J	K	M	BB	BB	BB	BB	BB	CB	CB	CB	CB	CB	CB	DC	DC	DC	DC	DC	DC	DC	EB	EB	EB	EB	EB	EB		
12,000 pF	123	J	K	M	BB	BB	BB	BB	BB	CB	CB	CB	CB	CB	CB	DC	DC	DC	DC	DC	DC	DC	EB	EB	EB	EB	EB	EB		
15,000 pF	153	J	K	M	BB	BB	BB	BB	BB	CB	CB	CB	CB	CB	CB	DC	DC	DC	DC	DC	DC	DC	EB	EB	EB	EB	EB	EB		
18,000 pF	183	J	K	M	BB	BB	BB	BB	BB	CB	CB	CB	CB	CB	CB	DC	DC	DC	DC	DC	DD	DC	EB	EB	EB	EB	EB	EB		
22,000 pF	223	J	K	M	BB	BB	BB	BB	BB	CB	CB	CB	CB	CB	CB	DC	DC	DC	DC	DC	DD	DC	EB	EB	EB	EB	EB	EB		
27,000 pF	273	J	K	M	BB	BB	BB	BB	BB	CB	CB	CB	CB	CB	CB	DC	DC	DC	DC	DC	DD	DE	EB	EB	EB	EB	EB	EB		
33,000 pF	333	J	K	M	BB	BB	BB	BB	BB	CB	CB	CB	CB	CB	CB	DC	DC	DC	DC	DC	DD	DE	EB	EB	EB	EB	EB	EB		
39,000 pF	393	J	K	M	BB	BB	BB	BB	BB	CB	CB	CB	CB	CB	CB	DC	DC	DC	DC	DC	DD	DE	EB	EB	EB	EB	EB	EB		
47,000 pF	473	J	K	M	BB	BB	BB	BB	BB	CB	CB	CB	CB	CB	CB	DC	DC	DC	DC	DC	DE	DG	EB	EB	EB	EB	EB	EB		
56,000 pF	563	J	K	M	BB	BB	BB	BB	BB	CB	CB	CB	CB	CB	CB	DD	DD	DD	DD	DD	DE	DG	EB	EB	EB	EB	EB	EB		
68,000 pF	683	J	K	M	BB	BB	BB	BB	BB	CB	CB	CB	CB	CB	CB	DD	DD	DD	DD	DD	DE	DG	EB	EB	EB	EB	EB	EB		
82,000 pF	823	J	K	M	BB	BB	BB	BB	BB	CB	CB	CB	CB	CB	CB	DD	DD	DD	DD	DD	DE	DG	EB	EB	EB	EB	EB	EB		
0.10 μF	104	J	K	M	BB	BB	BB	BB	BB	CB	CB	CB	CB	CB	CB	DD	DD	DD	DD	DD	DE	DG	EB	EB	EB	EB	EB	EB		
0.12 μF	124	J	K	M						CB	CB	CB	CB			DC	DC	DC	DC	DD	DG		EC	EC	EC	EC	EC	EC		
0.15 μF	154	J	K	M						CB	CB	CB	CB			DC	DC	DC	DC	DD	DG		EC	EC	EC	EC	EC	EC		
0.18 μF	184	J	K	M						CB	CB	CB	CB			DC	DC	DC	DC	DD	DG		EC	EC	EC	EC	EC	EC		
0.22 μF	224	J	K	M						CB	CB	CB	CD			DC	DC	DC	DC	DD	DG		EC	EC	EC	EC	EC	EC		
0.27 μF	274	J	K	M						CB	CB	CB				DD	DD	DD	DD	DD			EB	EB	EB	EB	EC	EM		
0.33 μF	334	J	K	M						CB	CB	CB				DD	DD	DD	DD	DD			EB	EB	EB	EB	EC	EG		
0.39 μF	394	J	K	M						CB	CB	CB				DG	DG	DG	DG	DE			EB	EB	EB	EB	EC	EG		
0.47 μF	474	J	K	M						CB	CB	CB				DD	DD	DD	DD	DE			EC	EC	EC	EC	EC	EG		
0.56 μF	564	J	K	M												DD	DD	DD	DG	DH			ED	ED	ED	ED	EC			
0.68 μF	684	J	K	M												DD	DD	DD	DG	DH			EE	EE	EE	EE	ED			
0.82 μF	824	J	K	M												DD	DD	DD	DG				EF	EF	EF	EF	ED			
1.0 μF	105	J	K	M												DD	DD	DD	DG				EF	EF	EF	EG	ED			
1.2 μF	125	J	K	M												DE	DE	DE					ED	ED	ED	EG	EH			
1.5 μF	155	J	K	M												DG	DG	DG					EF	EF	EF	EG	EH			
1.8 μF	185	J	K	M												DG	DG	DG					EF	EF	EF	EG	EH			
2.2 μF	225	J	K	M												DG	DG	DG					ED	ED	ED	EF	EH			
2.7 μF	275	J	K	M																			EN	EN	EN	EH				
3.3 μF	335	J	K	M																			ED	ED	ED	EH				
Cap	Cap Code	Voltage DC			6.3	10	16	25	50	6.3	10	16	25	50	100	200	6.3	10	16	25	50	100	200	6.3	10	16	25	50	100	200
		Voltage Code			9	8	4	3	5	9	8	4	3	5	1	2	9	8	4	3	5	1	2	9	8	4	3	5	1	2
		Series			C0402					C0603						C0805						C1206								

Table 1A – (COTS) X7R Dielectric, (0402 - 1206 Case Sizes) con't

Cap	Cap Code	Series	C0402					C0603						C0805						C1206																		
		Voltage Code	9	8	4	3	5	9	8	4	3	5	1	2	9	8	4	3	5	1	2	9	8	4	3	5	1	2										
		Voltage DC	6.3	10	16	25	50	6.3	10	16	25	50	100	200	6.3	10	16	25	50	100	200	6.3	10	16	25	50	100	200										
Cap Tolerance	Product Availability and Chip Thickness Codes - See Table 2 for Chip Thickness Dimensions																																					
3.9 µF	395	J	K	M																						EF	EF	EF	EH									
4.7 µF	475	J	K	M																							EF	EF	EF	EH								
5.6 µF	565	J	K	M																							EH	EH	EH									
6.8 µF	685	J	K	M																							EH	EH	EH									
8.2 µF	825	J	K	M																							EH	EH	EH									
10 µF	106	J	K	M																							EH	EH	EH									
12 µF	126	J	K	M																							EH	EH	EH									

Cap	Cap Code	Voltage DC	Voltage Code	Series	C0402					C0603						C0805						C1206												
		6.3	10	16	25	50	6.3	10	16	25	50	100	200	6.3	10	16	25	50	100	200	6.3	10	16	25	50	100	200	6.3	10	16	25	50	100	200
		9	8	4	3	5	9	8	4	3	5	1	2	9	8	4	3	5	1	2	9	8	4	3	5	1	2	9	8	4	3	5	1	2

Table 1B – (1210 - 2220 Case Sizes)

Cap	Cap Code	Series	C1210								C1812					C2220			
		Voltage Code	9	8	4	3	5	1	2	3	5	1	2	A	3	5	1	2	
		Voltage DC	6.3	10	16	25	50	100	200	25	50	100	200	250	25	50	100	200	
Cap Tolerance	Product Availability and Chip Thickness Codes - See Table 2 for Chip Thickness Dimensions																		
2,200 pF	222	J	K	M	FB	FB	FB	FB	FB	FB									
2,700 pF	272	J	K	M	FB	FB	FB	FB	FB	FB									
3,300 pF	332	J	K	M	FB	FB	FB	FB	FB	FB									
3,900 pF	392	J	K	M	FB	FB	FB	FB	FB	FB									
4,700 pF	472	J	K	M	FB	FB	FB	FB	FB	FB									
5,600 pF	562	J	K	M	FB	FB	FB	FB	FB	FB									
6,800 pF	682	J	K	M	FB	FB	FB	FB	FB	FB	GB	GB	GB						
8,200 pF	822	J	K	M	FB	FB	FB	FB	FB	FB	GB	GB	GB						
10,000 pF	103	J	K	M	FB	FB	FB	FB	FB	FB	GB	GB	GB	GB					
12,000 pF	123	J	K	M	FB	FB	FB	FB	FB	FB	GB	GB	GB						
15,000 pF	153	J	K	M	FB	FB	FB	FB	FB	FB	GB	GB	GB						
18,000 pF	183	J	K	M	FB	FB	FB	FB	FB	FB	GB	GB	GB						
22,000 pF	223	J	K	M	FB	FB	FB	FB	FB	FB	GB	GB	GB	GB					
27,000 pF	273	J	K	M	FB	FB	FB	FB	FB	FB	GB	GB	GB						
33,000 pF	333	J	K	M	FB	FB	FB	FB	FB	FB	GB	GB	GB						
39,000 pF	393	J	K	M	FB	FB	FB	FB	FB	FB	GB	GB	GB						
47,000 pF	473	J	K	M	FB	FB	FB	FB	FB	FB	GB	GB	GB	GB					
56,000 pF	563	J	K	M	FB	FB	FB	FB	FB	FB	GB	GB	GB						
68,000 pF	683	J	K	M	FB	FB	FB	FB	FB	FB	GB	GB	GB						
82,000 pF	823	J	K	M	FB	FB	FB	FB	FB	FC	GB	GB	GB						
0.10 µF	104	J	K	M	FB	FB	FB	FB	FB	FD	GB	GB	GB						
0.12 µF	124	J	K	M	FB	FB	FB	FB	FB	FD	GB	GB	GB						
0.15 µF	154	J	K	M	FC	FC	FC	FC	FC	FD	GB	GB	GB						
0.18 µF	184	J	K	M	FC	FC	FC	FC	FC	FD	GB	GB	GB						
0.22 µF	224	J	K	M	FC	FC	FC	FC	FC	FD	GB	GB	GB						
0.27 µF	274	J	K	M	FC	FC	FC	FC	FC	FD	GB	GB	GG		JC	JC			
0.33 µF	334	J	K	M	FD	FD	FD	FD	FD	FD	GB	GB	GG		JC	JC			
0.39 µF	394	J	K	M	FD	FD	FD	FD	FD	FD	GB	GB	GG		JC	JC			
0.47 µF	474	J	K	M	FD	FD	FD	FD	FD	FD	GB	GB	GG		JC	JC			
0.56 µF	564	J	K	M	FD	FD	FD	FD	FD	FF	GC	GC	GG		JC	JC			

Cap	Cap Code	Voltage DC	Voltage Code	Series	C1210								C1812					C2220			
		6.3	10	16	25	50	100	200	25	50	100	200	250	25	50	100	200	25	50	100	200
		9	8	4	3	5	1	2	3	5	1	2	A	3	5	1	2				

Table 1B – (COTS) X7R Dielectric, (1210 - 2220 Case Sizes) con't

Cap	Cap Code	Series			C1210						C1812					C2220				
		Voltage Code			9	8	4	3	5	1	2	3	5	1	2	A	3	5	1	2
		Voltage DC			6.3	10	16	25	50	100	200	25	50	100	200	250	25	50	100	200
		Cap Tolerance			Product Availability and Chip Thickness Codes - See Table 2 for Chip Thickness Dimensions															
0.68 µF	684	J	K	M	FD	FD	FD	FD	FD	FG		GC	GC	GG		JC	JC			
0.82 µF	824	J	K	M	FF	FF	FF	FF	FF	FL		GE	GE	GG		JC	JC			
1.0 µF	105	J	K	M	FH	FH	FH	FH	FH	FM		GE	GE	GG		JC	JC			
1.2 µF	125	J	K	M	FH	FH	FH	FH	FH	FG						JC	JC			
1.5 µF	155	J	K	M	FH	FH	FH	FH	FH	FG						JC	JC			
1.8 µF	185	J	K	M	FH	FH	FH	FH	FG						JD	JD				
2.2 µF	225	J	K	M	FJ	FJ	FJ	FJ	FG			GO	GO		JF	JF				
2.7 µF	275	J	K	M	FE	FE	FE	FG	FH											
3.3 µF	335	J	K	M	FF	FF	FF	FM	FM											
3.9 µF	395	J	K	M	FG	FG	FG	FG	FK											
4.7 µF	475	J	K	M	FC	FC	FC	FG	FS			GK	GK							
5.6 µF	565	J	K	M	FF	FF	FF	FH												
6.8 µF	685	J	K	M	FG	FG	FG	FM												
8.2 µF	825	J	K	M	FH	FH	FH	FK												
10 µF	106	J	K	M	FH	FH	FH	FS				GK			JF	JO				
12 µF	126	J	K	M																
15 µF	156	J	K	M																
18 µF	186	J	K	M																
22 µF	226	J	K	M	FS	FS														
47 µF	476	J	K	M																
Cap	Cap Code	Voltage DC			6.3	10	16	25	50	100	200	25	50	100	200	250	25	50	100	200
		Voltage Code			9	8	4	3	5	1	2	3	5	1	2	A	3	5	1	2
		Series			C1210						C1812					C2220				

Telecom "Tip and Ring," X7R Dielectric, 250VDC (Commercial Grade)

Overview

KEMET's 250V DC Tip and Ring MLCCs in X7R dielectric are designed and rated for telecommunication ringer circuits where the capacitor is used to block -48V to -52V DC of line voltage and pass a 16-25 Hz AC signal pulse of 70 VRMs to 90 VRMs. Serving as an excellent replacement for high voltage leaded film devices, these smaller surface mount technology footprints save valuable board space which is critical when creating new designs.

KEMET Tip and Ring capacitors feature a 125°C maximum operating temperature and are considered "temperature stable." The Electronics Components, Assemblies & Materials Association (EIA) characterizes X7R dielectric as a Class II

material. Components of this classification are fixed, ceramic dielectric capacitors suited for bypass and decoupling applications or for frequency discriminating circuits where Q and stability of capacitance characteristics are not critical. X7R dielectric exhibits a predictable change in capacitance with respect to time and voltage and boasts a minimal change in capacitance with reference to ambient temperature. Capacitance change is limited to $\pm 15\%$ from -55°C to +125°C.

These devices are able to withstand today's higher lead-free reflow processing temperatures and offer superior high frequency filtering characteristics and low ESR.

Benefits

- -55°C to +125°C operating temperature range
- Pb-Free and RoHS compliant
- EIA 0805, 1206, 1210, 1812, 1825, 2220 and 2225 case sizes
- DC voltage rating of 250V
- Capacitance offerings ranging from 1000pF to 6.8 μ F
- Available capacitance tolerances of $\pm 10\%$ and $\pm 20\%$
- Non-polar device, minimizing installation concerns
- 100% pure matte tin-plated termination finish that allows for excellent solderability
- SnPb termination finish option available upon request (5% min)
- Flexible termination option available upon request

Applications

Typical applications include telecommunication ringing circuits, switch mode power supply snubber circuits, high voltage DC blocking and high voltage coupling. Markets include telephone lines, analog and digital modems, facsimile machines, wireless base stations, cable and digital video recording set-top boxes, satellite dishes, high voltage power supply, DC/DC converters, and Ethernet, POS and ATM hardware.

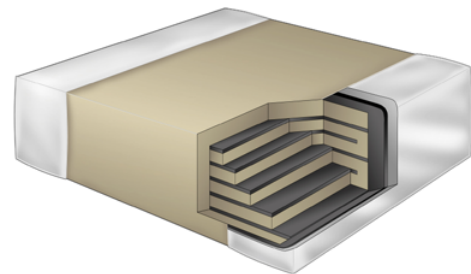

Ordering Information

C	1825	C	105	K	A	R	A	C	TU
Ceramic	Case Size (L" x W")	Specification/ Series	Capacitance Code (pF)	Capacitance Tolerance	Voltage	Dielectric	Failure Rate/ Design	Termination Finish ¹	Packaging/Grade (C-Spec) ²
	0805 1206 1210 1812 1825 2220 2225	C = Standard X = Flexible Termination	2 Sig. Digits + Number of Zeros	J = $\pm 5\%$ K = $\pm 10\%$ M = $\pm 20\%$	A = 250V	R = X7R	A = N/A	C = 100% Matte Sn L = SnPb (5% min)	Blank = Bulk TU = 7" Reel Unmarked TM = 7" Reel Marked

¹ Additional termination finish options may be available. Contact KEMET for details.

² Additional reeling or packaging options may be available. Contact KEMET for details.

Dimensions – Millimeters (Inches) Standard Termination

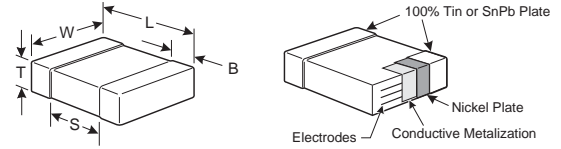

EIA Size Code	Metric Size Code	L Length	W Width	T Thickness	B Bandwidth	S Separation Minimum	Mounting Technique
0805	2012	2.00 (.079) ± 0.20 (.008)	1.25 (.049) ± 0.20 (.008)	See Table 2 for Thickness	0.50 (0.02) ± 0.25 (.010)	0.75 (.030)	Solder Wave or Solder Reflow
1206	3216	3.20 (.126) ± 0.20 (.008)	1.60 (.063) ± 0.20 (.008)		0.50 (0.02) ± 0.25 (.010)	N/A	
1210	3225	3.20 (.126) ± 0.20 (.008)	2.50 (.098) ± 0.20 (.008)		0.50 (0.02) ± 0.25 (.010)		
1812	4532	4.50 (.177) ± 0.30 (.012)	3.20 (.126) ± 0.30 (.012)		0.60 (.024) ± 0.35 (.014)		
1825	4564	4.50 (.177) ± 0.30 (.012)	6.40 (.252) ± 0.40 (.016)		0.60 (.024) ± 0.35 (.014)		
2220	5650	5.70 (.224) ± 0.40 (.016)	5.00 (.197) ± 0.40 (.016)		0.60 (.024) ± 0.35 (.014)		
2225	5664	5.60 (.220) ± 0.40 (.016)	6.40 (.248) ± 0.40 (.016)		0.60 (.024) ± 0.35 (.014)		

Dimensions – Millimeters (Inches) Flexible Termination option

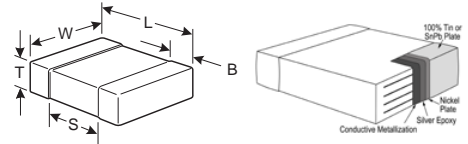

EIA Size Code	Metric Size Code	L Length	W Width	T Thickness	B Bandwidth	S Separation Minimum	Mounting Technique
0805	2012	2.10 (.083) +0.30 (.012) / -0.20 (.008)	1.25 (.049) ± 0.20 (.008)	See Table 2 for Thickness	0.50 (0.02) +0.10(.004) / -0.25 (.010)	0.50 (.020)	Solder Wave or Solder Reflow
1206	3216	3.3 (.130) ± 0.40 (.016)	1.60 (.063) ± 0.20 (.008)		0.60 (.024) ± 0.25 (.010)	0.70 (.028)	
1210	3225	3.3 (.130) ± 0.40 (.016)	2.50 (.098) ± 0.20 (.008)		0.60 (.024) ± 0.25 (.010)	N/A	Solder Reflow Only
1812	4532	4.5 (.178) ± 0.40 (.016)	3.20 (.126) ± 0.30 (.012)		0.70 (.028) ± 0.35 (.014)		
1825	4564	4.6 (.181) ± 0.40 (.016)	6.40 (.252) ± 0.40 (.016)		0.70 (.028) ± 0.35 (.014)		
2220	5650	5.9 (.232) ± 0.75 (.030)	5.00 (.197) ± 0.40 (.016)		0.70 (.028) ± 0.35 (.014)		
2225	5664	5.9 (.232) ± 0.75 (.030)	6.40 (.248) ± 0.40 (.016)		0.70 (.028) ± 0.35 (.014)		

Qualification/Certification

Commercial grade products are subject to internal qualification. Details regarding test methods and conditions are referenced in Table 4, Performance and Reliability.

Environmental Compliance

Pb-Free and RoHS compliant (excluding SnPb termination finish option)

Electrical Parameters/Characteristics

Item	Parameters/Characteristics
Operating Temperature Range	-55°C to +125°C
Capacitance Change with Reference to +25°C and 0 Vdc Applied (TCC)	±15%
Aging Rate (Max % Cap Loss/Decade Hour)	3.0%
Dielectric Withstanding Voltage	250% of rated voltage (5 ± 1 seconds and charge/discharge not exceeding 50mA)
Dissipation Factor (DF) Maximum Limits @ 25°C	5%(10V), 3.5%(16V & 25V) and 2.5%(50V–250V)
Insulation Resistance (IR) Limit @ 25°C	See Insulation Resistance Limit Table (Rated voltage applied for 120 ± 5 secs @ 25°C)

Regarding Aging Rate: Capacitance measurements (including tolerance) are indexed to a referee time of 1000 Hours.

To obtain IR limit, divide MΩ-μF value by the capacitance and compare to GΩ limit. Select the lower of the two limits.

Capacitance and Dissipation Factor (DF) measured under the following conditions:

1kHz ± 50Hz and 1.0 ± 0.2 Vrms if capacitance ≤ 10μF

120Hz ± 10Hz and 0.5 ± 0.1 Vrms if capacitance > 10μF

Note: When measuring capacitance it is important to ensure the set voltage level is held constant. The HP4284 & Agilent E4980 have a feature known as Automatic Level Control (ALC). The ALC feature should be switched to "ON".

Post Environmental Limits

High Temperature Life, Biased Humidity, Moisture Resistance					
Dielectric	Rated DC Voltage	Capacitance Value	DF (%)	Cap Shift	IR
X7R	>25	All	3.0	± 20%	10% of Initial Limit
	16 / 25		5.0		
	< 16		7.5		

Insulation Resistance Limit Table

EIA Case Size	1000 megohm microfarads or 100GΩ	500 megohm microfarads or 10GΩ
0201	N/A	ALL
0402	< .012μF	≥ .012μF
0603	< .047μF	≥ .047μF
0805	< .047μF	≥ .047μF
1206	< 0.22μF	≥ 0.22μF
1210	< 0.39μF	≥ 0.39μF
1808	ALL	N/A
1812	< 2.2μF	≥ 2.2μF
1825	ALL	N/A
2220	< 10μF	≥ 10μF
2225	ALL	N/A

Table 1 – “Tip and Ring,” X7R Dielectric, (0805 - 2225 Case Sizes)

Cap	Cap Tol.	Series			C0805C	C1206C	C1210C	C1812C	C1825C	C2220C	C2225C
		Voltage Code			A	A	A	A	A	A	A
		Voltage DC			250	250	250	250	250	250	250
		Cap Tolerance			Product Availability and Chip Thickness Codes - See Table 2 for Chip Thickness Dimensions						
150 pF	151	J	K	M							
180 pF	181	J	K	M	DC						
220 pF	221	J	K	M	DC						
270 pF	271	J	K	M	DC						
330 pF	331	J	K	M	DC						
390 pF	391	J	K	M	DC						
470 pF	471	J	K	M	DC						
560 pF	561	J	K	M	DC						
680 pF	681	J	K	M	DC						
820 pF	821	J	K	M	DC						
1,000 pF	102	J	K	M	DC	EB					
1,200 pF	122	J	K	M	DC	EB					
1,500 pF	152	J	K	M	DC	EB					
1,800 pF	182	J	K	M	DC	EB					
2,200 pF	222	J	K	M	DC	EB	FB				
2,700 pF	272	J	K	M	DC	EB	FB				
3,300 pF	332	J	K	M	DC	EB	FB				
3,900 pF	392	J	K	M	DC	EB	FB				
4,700 pF	472	J	K	M	DC	EB	FB				
5,600 pF	562	J	K	M	DC	EB	FB				
6,800 pF	682	J	K	M	DC	EB	FB	GB			
8,200 pF	822	J	K	M	DC	EB	FB	GB			
10,000 pF	103	J	K	M	DC	EB	FB	GB			
12,000 pF	123	J	K	M	DC	EB	FB	GB			
15,000 pF	153	J	K	M	DC	EB	FB	GB			
18,000 pF	183	J	K	M	DC	EB	FB	GB			
22,000 pF	223	J	K	M	DC	EB	FB	GB	HB		
27,000 pF	273	J	K	M		EB	FB	GB	HB		
33,000 pF	333	J	K	M		EB	FB	GB	HB		
39,000 pF	393	J	K	M		EB	FB	GB	HB		
47,000 pF	473	J	K	M		ED	FC	GB	HB	KC	
56,000 pF	563	J	K	M		ED	FC	GB	HB	KC	
68,000 pF	683	J	K	M		ED	FC	GB	HB	KC	
82,000 pF	823	J	K	M		ED	FF	GB	HB	JC	
0.10 µF	104	J	K	M		EM	FG	GB	HB	JC	
0.12 µF	124	J	K	M				GB	HB	JC	
0.15 µF	154	J	K	M				GE	HB	JC	
0.18 µF	184	J	K	M				GG	HB	JC	
0.22 µF	224	J	K	M				GG	HB	JC	
0.27 µF	274	J	K	M				GG	HB	JC	
0.33 µF	334	J	K	M				GG	HB	JC	
0.39 µF	394	J	K	M				GG	HD	JC	
0.47 µF	474	J	K	M				GJ	HD	JC	
0.56 µF	564	J	K	M					HD	JD	
0.68 µF	684	J	K	M					HD	JD	
0.82 µF	824	J	K	M					HF	JF	
1.0 µF	105	J	K	M					HF	JF	
1.2 µF	125	J	K	M							
1.5 µF	155	J	K	M							
1.8 µF	185	J	K	M							
2.2 µF	225	J	K	M							
2.7 µF	275	J	K	M							
3.3 µF	335	J	K	M							
3.9 µF	395	J	K	M							
4.7 µF	475	J	K	M							
Cap	Cap Tol.	Voltage DC			250	250	250	250	250	250	250
		Voltage Code			A	A	A	A	A	A	A
		Series			C0805C	C1206C	C1210C	C1812C	C1825C	C2220C	C2225C

Open Mode Design (FO-CAP), X7R Dielectric, 16VDC-200VDC (Commercial & Automotive Grade)

Overview

KEMET's Ceramic Open Mode capacitor in X7R dielectric is designed to significantly minimize the probability of a low IR or short circuit condition when forced to failure in a board stress flex situation, thus reducing the potential for catastrophic failure. The Open Mode capacitor may experience a drop in capacitance; however, a short is unlikely because a crack will not typically propagate across counter electrodes within the device's "active area." Since there will not be any current leakage associated with a typical Open Mode flex crack, there is no localized heating and therefore little chance for a catastrophic and potentially costly failure event.

Driven by the demand for a more robust and reliable component, the Open Mode capacitor was designed for critical applications where higher operating temperatures and mechanical stress are

a concern. These capacitors are manufactured in state of the art ISO/TS 16949:2002 certified facilities and are widely used in automotive circuits as well as power supplies (input and output filters) and general electronic applications.

When combined with flexible termination technology these devices offer the ultimate level of protection against a low IR or short circuit condition. Open Mode devices compliment KEMET's Floating Electrode (FE-CAP) and Floating Electrode with Flexible Termination (FF-CAP) product lines by providing a fail-safe design optimized for mid to high range capacitance values. These devices exhibit a predictable change in capacitance with respect to time and voltage and boast a minimal change in capacitance with reference to ambient temperature. Capacitance change is limited to $\pm 15\%$ from -55°C to $+125^{\circ}\text{C}$.

Benefits

- -55°C to $+125^{\circ}\text{C}$ operating temperature range
- Open Mode/fail open design
- Mid to high capacitance flex mitigation
- Pb-Free and RoHS compliant
- EIA 0805, 1206, 1210 and 1812 case sizes
- DC voltage ratings of 16V, 25V, 50V, 100V and 200V
- Capacitance offerings ranging from 1000pF to 6.8 μF
- Available capacitance tolerances of $\pm 5\%$, $\pm 10\%$ and $\pm 20\%$
- Non-polar device, minimizing installation concerns
- 100% pure matte tin-plated termination finish allowing for excellent solderability

- SnPb termination finish option available upon request (5% min)
- Commercial and Automotive (AEC-Q200) grades available
- SnPb termination finish option available upon request (5% min)
- Flexible termination option available upon request

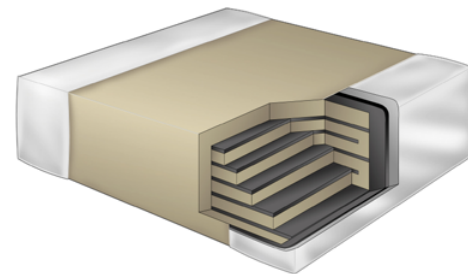

Ordering Information

C	1210	J	685	K	3	R	A	C	TU
Ceramic	Case Size (L" x W")	Specification/ Series	Capacitance Code (pF)	Capacitance Tolerance	Voltage	Dielectric	Failure Rate/ Design	Termination Finish ¹	Packaging/Grade (C-Spec) ²
	0805 1206 1210 1812	F = Open Mode J = Open Mode w/Flexible Termination	2 Sig. Digits + Number of Zeros	K = $\pm 10\%$ M = $\pm 20\%$	4 = 16V 3 = 25V 5 = 50V 1 = 100V 2 = 200V	R = X7R	A = N/A	C = 100% Matte Sn L = SnPb (5% min)	Blank = Bulk TU = 7" Reel Unmarked TM = 7" Reel Marked AUTO = Automotive Grade

¹ Additional termination finish options may be available. Contact KEMET for details.

^{1,2} SnPb termination finish option is not available on automotive grade product.

² Additional reeling or packaging options may be available. Contact KEMET for details.

Dimensions – Standard Termination – Millimeters (Inches)

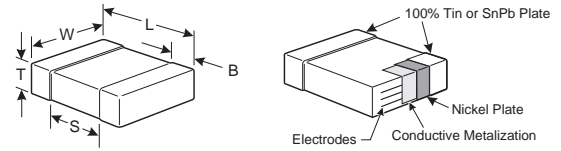

EIA Size Code	Metric Size Code	L Length	W Width	T Thickness	B Bandwidth	S Separation Min.	Mounting Technique
0805	2012	2.00 (.079) ± 0.20 (.008)	1.25 (.049) ± 0.20 (.008)	See Table 2 for Thickness	0.50 (0.02) ± 0.25 (.010)	0.75 (.030)	Solder Wave or Solder Reflow
1206	3216	3.20 (.126) ± 0.20 (.008)	1.60 (.063) ± 0.20 (.008)		0.50 (0.02) ± 0.25 (.010)	N/A	
1210	3225	3.20 (.126) ± 0.20 (.008)	2.50 (.098) ± 0.20 (.008)		0.50 (0.02) ± 0.25 (.010)		Solder Reflow Only
1812	4532	4.50 (.177) ± 0.30 (.012)	3.20 (.126) ± 0.30 (.012)		0.60 (.024) ± 0.35 (.014)		

Dimensions – Flexible Termination – Millimeters (Inches)

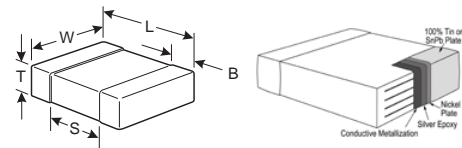

EIA Size Code	Metric Size Code	L Length	W Width	T Thickness	B Bandwidth	S Separation Min.	Mounting Technique
0805	2012	2.10 (.083) +0.30 (.012) / -0.20 (.008)	1.25 (.049) ± 0.20 (.008)	See Table 2 for Thickness	0.50 (0.02) +0.10 (.004) / -0.25 (.010)	0.70 (.028)	Solder Wave or Solder Reflow
1206	3216	3.30 (.130) ± 0.40 (.016)	1.60 (.063) ± 0.20 (.008)		0.60 (.024) ± 0.25 (.010)	N/A	
1210	3225	3.30 (.130) ± 0.40 (.016)	2.50 (.098) ± 0.20 (.008)		0.60 (.024) ± 0.25 (.010)		Solder Reflow Only
1812	4532	4.50 (.178) ± 0.40 (.016)	3.20 (.126) ± 0.30 (.012)		0.70 (.028) ± 0.35 (.014)		

Applications

Typical applications include input side filtering (power plane/bus), high current (battery line) and circuits that cannot be fused to open when short circuits occur due to flex cracks. Markets include automotive applications that are directly connected to the battery and/or involve conversion to a 42V system and raw power input side filtering in power conversion.

Qualification/Certification

Commercial grade products are subject to internal qualification. Details regarding test methods and conditions are referenced in Table 4, Performance and Reliability.

Automotive grade products meet or exceed the requirements outlined by the Automotive Electronics Council. Details regarding test methods and conditions are referenced in document AEC-Q200, Stress Test Qualification for Passive Components. For additional information regarding the Automotive Electronics Council and AEC-Q200, please visit their website at www.aecouncil.com.

Environmental Compliance

Pb-Free and RoHS compliant (excluding SnPb termination finish option).

Electrical Parameters/Characteristics

Item	Parameters/Characteristics
Operating Temperature Range	-55°C to +125°C
Capacitance Change with Reference to +25°C and 0 Vdc Applied (TCC)	±15%
Aging Rate (Max % Cap Loss/Decade Hour)	3.0%
Dielectric Withstanding Voltage	250% of rated voltage (5 ± 1 seconds and charge/discharge not exceeding 50mA)
Dissipation Factor (DF) Maximum Limits @ 25°C	5% (10V), 3.5% (16V & 25V) and 2.5% (50V to 250V)
Insulation Resistance (IR) Limit @ 25°C	See Insulation Resistance Limit Table (Rated voltage applied for 120 ± 5 secs @ 25°C)

Regarding Aging Rate: Capacitance measurements (including tolerance) are indexed to a referee time of 1000 hours.

To obtain IR limit, divide $M\Omega\text{-}\mu F$ value by the capacitance and compare to $G\Omega$ limit. Select the lower of the two limits.

Capacitance and Dissipation Factor (DF) measured under the following conditions:

1kHz ± 50Hz and 1.0 ± 0.2 Vrms if capacitance $\leq 10\mu F$

120Hz ± 10Hz and 0.5 ± 0.1 Vrms if capacitance $> 10\mu F$

Note: When measuring capacitance it is important to ensure the set voltage level is held constant. The HP4284 & Agilent E4980 have a feature known as Automatic Level Control (ALC). The ALC feature should be switched to "ON."

Post Environmental Limits

High Temperature Life, Biased Humidity, Moisture Resistance					
Dielectric	Rated DC Voltage	Capacitance Value	DF (%)	Cap Shift	IR
X7R	>25	All	3.0	± 20%	10% of Initial Limit
	16 / 25		5.0		
	< 16		7.5		

Insulation Resistance Limit Table

EIA Case Size	1000 megohm microfarads or 100GΩ	500 megohm microfarads or 10GΩ
0201	N/A	ALL
0402	< .012μF	≥ .012μF
0603	< .047μF	≥ .047μF
0805	< .047μF	≥ .047μF
1206	< 0.22μF	≥ 0.22μF
1210	< 0.39μF	≥ 0.39μF
1808	ALL	N/A
1812	< 2.2μF	≥ 2.2μF
1825	ALL	N/A
2220	< 10μF	≥ 10μF
2225	ALL	N/A

Table 1 – Open Mode Design, X7R Dielectric, (0805 - 1812 Case Sizes)

Cap	Cap Code	Series		C0805F/J					C1206F/J					C1210F/J					C1812F/J			
		Voltage Code		4	3	5	1	2	4	3	5	1	2	4	3	5	1	2	3	5	1	2
		Voltage DC		16	25	50	100	200	16	25	50	100	200	16	25	50	100	200	25	50	100	200
		Cap Tolerance		Product Availability and Chip Thickness Codes - See Table 2 for Chip Thickness Dimensions																		
1,000 pF	102	K	M	DD	DD	DD	DD	DD														
1,200 pF	122	K	M	DD	DD	DD	DD	DD														
1,500 pF	152	K	M	DD	DD	DD	DD	DD														
1,800 pF	182	K	M	DD	DD	DD	DD	DD														
2,200 pF	222	K	M	DD	DD	DD	DD	DD														
2,700 pF	272	K	M	DD	DD	DD	DD	DD														
3,300 pF	332	K	M	DD	DD	DD	DD	DD														
3,900 pF	392	K	M	DD	DD	DD	DD	DD														
4,700 pF	472	K	M	DD	DD	DD	DD	DD														
5,600 pF	562	K	M	DD	DD	DD	DD	DD														
6,800 pF	682	K	M	DD	DD	DD	DD	DD														
8,200 pF	822	K	M	DD	DD	DD	DD	DD														
10,000 pF	103	K	M	DD	DD	DD	DD	DD														
12,000 pF	123	K	M	DD	DD	DD	DD	DG														
15,000 pF	153	K	M	DD	DD	DD	DD	DG														
18,000 pF	183	K	M	DD	DD	DD	DD		EC	EC	EC	EC	EC									
22,000 pF	223	K	M	DD	DD	DD	DG		EC	EC	EC	EC	EC									
27,000 pF	273	K	M	DD	DD	DD	DG		EC	EC	EC	EC	EC									
33,000 pF	333	K	M	DD	DD	DD	DG		EC	EC	EC	EC	EC									
39,000 pF	393	K	M	DD	DD	DD	DG		EC	EC	EC	EC	EC									
47,000 pF	473	K	M	DD	DD	DD	DE		EC	EC	EC	EC	EG					GB	GB	GB	GB	
56,000 pF	563	K	M	DD	DD	DD			EC	EC	EC	EC	EG					GB	GB	GB	GB	
68,000 pF	683	K	M	DD	DD	DG	DG		EC	EC	EC	EC	EG	FD	FD	FD	FD	GB	GB	GB	GB	
82,000 pF	823	K	M	DD	DD	DG			EC	EC	EC	EC	EG	FD	FD	FD	FD	GB	GB	GB	GB	
0.10 µF	104	K	M	DG	DG	DG			EC	EC	EC	EC	EG	FD	FD	FD	FD	GB	GB	GB	GB	
0.12 µF	124	K	M	DG	DG				EC	EC	EC	EC		FD	FD	FD	FD	FG	GB	GB	GB	
0.15 µF	154	K	M	DG	DG				EC	EC	EC	EG		FD	FD	FD	FD	FH	GB	GB	GB	
0.18 µF	184	K	M	DG	DG				EC	EC	EC	EG		FD	FD	FD	FD	FH	GB	GB	GB	
0.22 µF	224	K	M	DG	DD	DG			EC	EC	EC	ED		FD	FD	FD	FD	FJ	GB	GB	GB	
0.27 µF	274	K	M	DD	DD				EC	EC	EC			FD	FD	FD	FG		GB	GB	GB	
0.33 µF	334	K	M	DD	DG				EG	EG	EG	EG		FD	FD	FD	FH		GB	GB	GB	
0.39 µF	394	K	M	DD	DG				EG	EG				FD	FD	FG	FH		GB	GB	GB	
0.47 µF	474	K	M	DE	DG				EG	EG	EC			FD	FD	FG	FJ		GB	GB	GB	
0.56 µF	564	K	M						EG					FD	FD	FG	FR		GB	GB	GD	
0.68 µF	684	K	M	DG					EG					FD	FG	FH	FR		GD	GD	GF	
0.82 µF	824	K	M						EG					FD	FG	FH			GD	GD	GK	
1.0 µF	105	K	M						EG	EC	EH			FD	FH	FJ	FS		GN	GN	GM	
1.2 µF	125	K	M											FG								
1.5 µF	155	K	M											FH								
1.8 µF	185	K	M											FH								
2.2 µF	225	K	M						EC	EH				FJ	FM	FM						
2.7 µF	275	K	M																			
3.3 µF	335	K																				
3.9 µF	395	K	M																			
4.7 µF	475	K	M						EH					FG	FM							
6.8 µF	685	K	M											FS	FS							
Cap	Cap Code	Voltage DC		16	25	50	100	200	16	25	50	100	200	16	25	50	100	200	25	50	100	200
		Voltage Code		4	3	5	1	2	4	3	5	1	2	4	3	5	1	2	3	5	1	2
		Series		C0805F					C1206F					C1210F					C1812F			

Table 2 – Chip Thickness/Packaging Quantities

Thickness Code	Chip Size	Thickness ± Range (mm)	QTY per Reel 7" Plastic	QTY per Reel 13" Plastic	QTY per Reel 7" Paper	QTY per Reel 13" Paper	QTY per Bulk Cassette
AA	1005	0.20 ± 0.02			15000		
AB	0201	0.30 ± 0.03			15000		
BB	0402	0.50 ± 0.05			10000	50000	50000
BC	0402	0.50 ± 0.10			10000	50000	50000
PA	0508	0.80 ± 0.10	4000	10000			
CB	0603	0.80 ± 0.07			4000	10000	15000
CC	0603	0.80 ± 0.10			4000	10000	15000
CD	0603	0.80 ± 0.15			4000	10000	15000
MA	0612	0.80 ± 0.10	4000	10000			
DB	0805	0.60 ± 0.10			4000	10000	15000
DC	0805	0.78 ± 0.10			4000	10000	15000
DD	0805	0.90 ± 0.10			4000	10000	15000
DL	0805	0.95 ± 0.10	4000	10000			
DE	0805	1.00 ± 0.10	2500	10000			
DF	0805	1.10 ± 0.10	2500	10000			
DG	0805	1.25 ± 0.15	2500	10000			
DH	0805	1.25 ± 0.20	2500	10000			
EB	1206	0.78 ± 0.10	4000	10000	4000	10000	
EK	1206	0.80 ± 0.10	2000	8000			
EC	1206	0.90 ± 0.10	4000	10000			
EN	1206	0.95 ± 0.10	4000	10000			
ED	1206	1.00 ± 0.10	2500	10000			
EE	1206	1.10 ± 0.10	2500	10000			
EF	1206	1.20 ± 0.15	2500	10000			
EM	1206	1.25 ± 0.15	2500	10000			
EG	1206	1.60 ± 0.15	2000	8000			
EH	1206	1.60 ± 0.20	2000	8000			
EJ	1206	1.70 ± 0.20	2000	8000			
FB	1210	0.78 ± 0.10	4000	10000			
FC	1210	0.90 ± 0.10	4000	10000			
FD	1210	0.95 ± 0.10	4000	10000			
FE	1210	1.00 ± 0.10	2500	10000			
FF	1210	1.10 ± 0.10	2500	10000			
FG	1210	1.25 ± 0.15	2500	10000			
FL	1210	1.40 ± 0.15	2000	8000			
FO	1210	1.50 ± 0.20	2000	8000			
FH	1210	1.55 ± 0.15	2000	8000			
FP	1210	1.60 ± 0.20	2000	8000			
FM	1210	1.70 ± 0.20	2000	8000			
FJ	1210	1.85 ± 0.20	2000	8000			
FN	1210	1.85 ± 0.20	2000	8000			
FT	1210	1.90 ± 0.20	1500	4000			
FK	1210	2.10 ± 0.20	2000	8000			
FR	1210	2.25 ± 0.20	2000	8000			
FS	1210	2.50 ± 0.20	1000	4000			
FV	1210	3.35 ± 0.10	500	1800			
FW	1210	6.15 ± 0.15	200	1000			
PA	1220	0.80 ± 0.10	4000	10000			
MA	1632	0.80 ± 0.10	4000	10000			
NA	1706	0.90 ± 0.10	4000	10000			
NB	1706	1.00 ± 0.10	4000	10000			
NC	1706	1.00 ± 0.15	4000	10000			
LD	1808	0.90 ± 0.10	2500	10000			
LE	1808	1.00 ± 0.10	2500	10000			
LF	1808	1.00 ± 0.15	2500	10000			
LA	1808	1.40 ± 0.15	1000	4000			
LB	1808	1.60 ± 0.15	1000	4000			
LC	1808	2.00 ± 0.15	1000	4000			
GB	1812	1.00 ± 0.10	1000	4000			
GC	1812	1.10 ± 0.10	1000	4000			
GD	1812	1.25 ± 0.15	1000	4000			
GE	1812	1.30 ± 0.10	1000	4000			
GH	1812	1.40 ± 0.15	1000	4000			
GF	1812	1.50 ± 0.10	1000	4000			
GG	1812	1.55 ± 0.10	1000	4000			
GK	1812	1.60 ± 0.20	1000	4000			
GJ	1812	1.70 ± 0.15	1000	4000			
GN	1812	1.70 ± 0.20	1000	4000			
GL	1812	1.90 ± 0.20	1000	4000			
GM	1812	2.00 ± 0.20	1000	4000			
GO	1812	2.50 ± 0.20	500	2000			
GP	1812	2.65 ± 0.35	500	1400			
GR	1812	5.00 ± 0.50	350	1000			
HB	1825	1.10 ± 0.15	1000	4000			
HC	1825	1.15 ± 0.15	1000	4000			
HD	1825	1.30 ± 0.15	1000	4000			
HE	1825	1.40 ± 0.15	1000	4000			
HF	1825	1.50 ± 0.15	1000	4000			
Thickness Code	Chip Size	Thickness ± Range (mm)	QTY per Reel 7" Plastic	QTY per Reel 13" Plastic	QTY per Reel 7" Paper	QTY per Reel 13" Paper	QTY per Bulk Cassette

Package Quantity
 Based on Finished Chip
 Thickness Specifications

Table 2 – Chip Thickness/Packaging Quantities cont'

Thickness Code	Chip Size	Thickness ± Range (mm)	QTY per Reel 7" Plastic	QTY per Reel 13" Plastic	QTY per Reel 7" Paper	QTY per Reel 13" Paper	QTY per Bulk Cassette
HG	1825	1.60 ± 0.20	1000	4000			
JB	2220	1.00 ± 0.15	1000	4000			
JC	2220	1.10 ± 0.15	1000	4000			
JD	2220	1.30 ± 0.15	1000	4000			
JE	2220	1.40 ± 0.15	1000	4000			
JF	2220	1.50 ± 0.15	1000	4000			
JP	2220	1.60 ± 0.20	1000	4000			
JG	2220	1.70 ± 0.15	1000	4000			
JH	2220	1.80 ± 0.15	1000	4000			
JO	2220	2.40 ± 0.15	500	2000			
JP	2220	3.50 ± 0.30	250	850			
JR	2220	5.00 ± 0.50	150	600			
KB	2225	1.00 ± 0.15	1000	4000			
KC	2225	1.10 ± 0.15	1000	4000			
KD	2225	1.30 ± 0.15	1000	4000			
KE	2225	1.40 ± 0.15	1000	4000			
KF	2225	1.60 ± 0.20	1000	4000			
Thickness Code	Chip Size	Thickness ± Range (mm)	QTY per Reel 7" Plastic	QTY per Reel 13" Plastic	QTY per Reel 7" Paper	QTY per Reel 13" Paper	QTY per Bulk Cassette

Table 3A – Land Pattern Design Recommendations per IPC-7351 (Standard Termination)

EIA Size Code	Metric Size Code	Density Level A: Maximum (Most) Land Protrusion (mm)					Density Level B: Median (Nominal) Land Protrusion (mm)					Density Level C: Minimum (Least) Land Protrusion (mm)				
		C	Y	X	V1	V2	C	Y	X	V1	V2	C	Y	X	V1	V2
01005	0402	0.33	0.46	0.43	1.60	0.90	0.28	0.36	0.33	1.30	0.70	0.23	0.26	0.23	1.00	0.50
0201	0603	0.38	0.56	0.52	1.80	1.00	0.33	0.46	0.42	1.50	0.80	0.28	0.36	0.32	1.20	0.60
0402	1005	0.50	0.72	0.72	2.20	1.20	0.45	0.62	0.62	1.90	1.00	0.40	0.52	0.52	1.60	0.80
0603	1608	0.90	1.15	1.10	4.00	2.10	0.80	0.95	1.00	3.10	1.50	0.60	0.75	0.90	2.40	1.20
0805	2012	1.00	1.35	1.55	4.40	2.60	0.90	1.15	1.45	3.50	2.00	0.75	0.95	1.35	2.80	1.70
1206	3216	1.60	1.35	1.90	5.60	2.90	1.50	1.15	1.80	4.70	2.30	1.40	0.95	1.70	4.00	2.00
1210	3225	1.60	1.35	2.80	5.65	3.80	1.50	1.15	2.70	4.70	3.20	1.40	0.95	2.60	4.00	2.90
1808	4520	2.30	1.75	2.30	7.40	3.30	2.20	1.55	2.20	6.50	2.70	2.10	1.35	2.10	5.80	2.40
1812	4532	2.15	1.60	3.60	6.90	4.60	2.05	1.40	3.50	6.00	4.00	1.95	1.20	3.40	5.30	3.70
1825	4564	2.15	1.60	6.90	6.90	7.90	2.05	1.40	6.80	6.00	7.30	1.95	1.20	6.70	5.30	7.00
2220	5650	2.75	1.70	5.50	8.20	6.50	2.65	1.50	5.40	7.30	5.90	2.55	1.30	5.30	6.60	5.60
2225	5664	2.70	1.70	6.90	8.10	7.90	2.60	1.50	6.80	7.20	7.30	2.50	1.30	6.70	6.50	7.00

Density Level A: For low-density Product applications. Recommended for wave solder applications and provides a wider process window for reflow solder processes. KEMET only recommends wave soldering of EIA 0603, 0805 and 1206 case sizes.

Density Level B: For products with a moderate level of component density. Provides a robust solder attachment condition for reflow solder processes.

Density Level C: For high component density product applications. Before adapting the minimum land pattern variations the user should perform qualification testing based on the conditions outlined in IPC standard 7351 (IPC-7351).

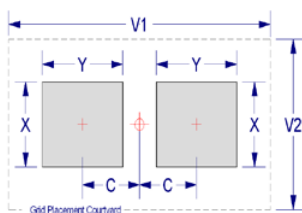

Table 3B – Land Pattern Design Recommendations per IPC-7351 (Flexible Termination)

EIA Size Code	Metric Size Code	Density Level A: Maximum (Most) Land Protrusion (mm)					Density Level B: Median (Nominal) Land Protrusion (mm)					Density Level C: Minimum (Least) Land Protrusion (mm)				
		C	Y	X	V1	V2	C	Y	X	V1	V2	C	Y	X	V1	V2
0603	1608	0.85	1.25	1.10	4.00	2.10	0.75	1.05	1.00	3.10	1.50	0.65	0.85	0.90	2.40	1.20
0805	2012	1.10	1.30	1.55	4.50	2.60	1.00	1.10	1.45	3.60	2.00	0.90	0.90	1.35	2.90	1.70
1206	3216	1.60	1.65	1.90	5.90	2.90	1.50	1.45	1.80	5.00	2.30	1.40	1.25	1.70	4.30	2.00
1210	3225	1.60	1.65	2.80	5.90	3.80	1.50	1.45	2.70	5.00	3.20	1.40	1.25	2.60	4.30	2.90
1808	4520	2.25	1.85	2.30	7.40	3.30	2.15	1.65	2.20	6.50	2.70	2.05	1.45	2.10	5.80	2.40
1812	4532	2.10	1.80	3.60	7.00	4.60	2.00	1.60	3.50	6.10	4.00	1.90	1.40	3.40	5.40	3.70
1825	4564	2.15	1.80	6.90	7.10	7.90	2.05	1.60	6.80	6.20	7.30	1.95	1.40	6.70	5.50	7.00
2220	5650	2.85	2.10	5.50	8.80	6.50	2.75	1.90	5.40	7.90	5.90	2.65	1.70	5.30	7.20	5.60
2225	5664	2.85	2.10	6.90	8.80	7.90	2.75	1.90	6.80	7.90	7.30	2.65	1.70	6.70	7.20	7.00

Density Level A: For low-density Product applications. Recommended for wave solder applications and provides a wider process window for reflow solder processes. KEMET only recommends wave soldering of EIA 0603, 0805 and 1206 case sizes.

Density Level B: For products with a moderate level of component density. Provides a robust solder attachment condition for reflow solder processes.

Density Level C: For high component density product applications. Before adapting the minimum land pattern variations the user should perform qualification testing based on the conditions outlined in IPC standard 7351 (IPC-7351).

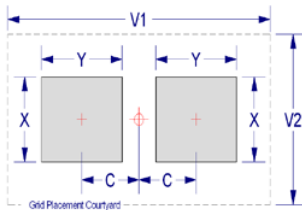

Soldering Process

Recommended Soldering Technique:

- Solder wave or solder reflow for EIA case sizes 0603, 0805 and 1206
- All other EIA case sizes are limited to solder reflow only

Recommended Soldering Profile:

- KEMET recommends following the guidelines outlined in IPC/JEDEC J-STD-020

Table 4 – Performance & Reliability: Test Methods and Conditions

Stress	Reference	Test or Inspection Method
Terminal Strength	JIS-C-6429	Appendix 1, Note: Force of 1.8kg for 60 seconds.
Board Flex	JIS-C-6429	Appendix 2, Note: 2mm (min) for all except 3mm for C0G.
Solderability	J-STD-002	Magnification 50 X. Conditions:
		a) Method B, 4 hours @ 155°C, dry heat @ 235°C
		b) Method B @ 215°C category 3
		c) Method D, category 3 @ 260°C
Temperature Cycling	JESD22 Method JA-104	1000 cycles (-55°C to +125°C). Measurement at 24 hours. +/- 2 hours after test conclusion.
Biased Humidity	MIL-STD-202 Method 103	Load Humidity: 1000 hours 85°C/85%RH and Rated Voltage. Add 100K ohm resistor. Measurement at 24 hours. +/- 2 hours after test conclusion.
		Low Volt Humidity: 1000 hours 85°C/85%RH and 1.5V. Add 100K ohm resistor. Measurement at 24 hours. +/- 2 hours after test conclusion.
Moisture Resistance	MIL-STD-202 Method 106	t = 24 hours/cycle. Steps 7a & 7b not required. Unpowered. Measurement at 24 hours. +/- 2 hours after test conclusion.
Thermal Shock	MIL-STD-202 Method 107	-55°C/+125°C. Note: Number of cycles required-300, maximum transfer time-20 seconds, dwell time-15 minutes. Air-Air.
High Temperature Life	MIL-STD-202 Method 108 / EIA -198	1000 hours at 125°C (85°C for X5R, Z5U and Y5V) with 2x rated voltage applied.
Storage Life	MIL-STD-202 Method 108	150°C, 0VDC, for 1000 hours.
Mechanical Shock	MIL-STD-202 Method 213	Figure 1 of Method 213, Condition F.
Resistance to Solvents	MIL-STD-202 Method 215	Add aqueous wash chemical - OKEM Clean or equivalent.

Storage and Handling

Ceramic chip capacitors should be stored in normal working environments. While the chips themselves are quite robust in other environments, solderability will be degraded by exposure to high temperatures, high humidity, corrosive atmospheres, and long term storage. In addition, packaging materials will be degraded by high temperature – reels may soften or warp, and tape peel force may increase. KEMET recommends that maximum storage temperature not exceed 40°C, and maximum storage humidity not exceed 70% relative humidity. In addition, temperature fluctuations should be minimized to avoid condensation on the parts, and atmospheres should be free of chlorine and sulfur bearing compounds. For optimized solderability, chip stock should be used promptly, preferably within 1.5 years of receipt.

Floating Electrode Design (FE-CAP) X7R Dielectric 6.3VDC-250VDC (Commercial Grade)

Overview

KEMET's Floating Electrode (FE-CAP) multilayer ceramic capacitor in X7R dielectric utilizes a cascading internal electrode design configured to form multiple capacitors in series within a single monolithic structure. This unique configuration results in enhanced voltage and ESD performance over standard capacitor designs while allowing for a fail-open condition if mechanically damaged (cracked). If damaged, the device may experience a drop in capacitance but a short is unlikely. The FE-CAP is designed to reduce the likelihood of a low IR or short circuit condition and the chance for a catastrophic and potentially costly failure event.

Driven by the demand for a more robust and reliable component, the FE-CAP was designed for critical applications where

higher operating temperatures and mechanical stress are a concern. These capacitors are manufactured in state of the art ISO/TS 16949:2002 certified facilities and are widely used in power supplies (input and output filters) and general electronic applications.

Combined with the stability of an X7R dielectric, the FE-CAP complements KEMET's "Open Mode" devices by providing a fail-safe design optimized for low to mid range capacitance values. These devices exhibit a predictable change in capacitance with respect to time and voltage and boast a minimal change in capacitance with reference to ambient temperature. Capacitance change is limited to $\pm 15\%$ from -55°C to $+125^{\circ}\text{C}$.

Benefits

- -55°C to $+125^{\circ}\text{C}$ operating temperature range
- Floating Electrode/fail open design
- Low to mid capacitance flex mitigation
- Pb-Free and RoHS compliant
- EIA 0402, 0603, 0805, 1206, 1210, and 1812 case sizes
- DC voltage ratings of 6.3V, 10V, 16V, 25V, 50V, 100V, 200V, and 250V
- Capacitance offerings ranging from 150pF to 0.22 μF
- Available capacitance tolerances of $\pm 5\%$, $\pm 10\%$ and $\pm 20\%$
- Non-polar device, minimizing installation concerns
- 100% pure matte tin-plated termination finish allowing for excellent solderability
- SnPb termination finish option available upon request (5% min)

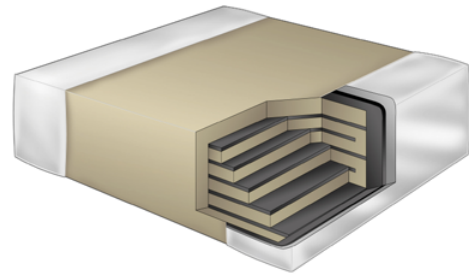

Ordering Information

C	0805	S	104	K	5	R	A	C	TU
Ceramic	Case Size (L" x W")	Specification/ Series	Capacitance Code (pF)	Capacitance Tolerance	Voltage	Dielectric	Failure Rate/ Design	Termination Finish ¹	Packaging/Grade (C-Spec) ²
	0402 0603 0805 1206 1210 1812	S = Floating Electrode	2 Sig. Digits + Number of Zeros	J = $\pm 5\%$ K = $\pm 10\%$ M = $\pm 20\%$	9 = 6.3V 8 = 10V 4 = 16V 3 = 25V 6 = 35V 5 = 50V 1 = 100V 2 = 200V A = 250V	R = X7R	A = N/A	C = 100% Matte Sn L = SnPb (5% min)	Blank = Bulk TU = 7" Reel Unmarked TM = 7" Reel Marked

¹ Additional termination finish options may be available. Contact KEMET for details.

² Additional reeling or packaging options may be available. Contact KEMET for details.

Dimensions – Millimeters (Inches)

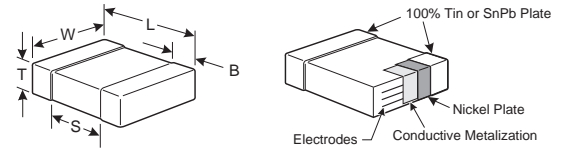

EIA Size Code	Metric Size Code	L Length	W Width	T Thickness	B Bandwidth	S Separation Min.	Mounting Technique
0402	1005	1.00 (.040) ± 0.05 (.002)	0.50 (.020) ± 0.05 (.002)	See Table 2 for Thickness	0.30 (.012) ± 0.10 (.004)	0.30 (.012)	Solder Reflow Only
0603	1608	1.60 (.063) ± 0.15 (.006)	0.80 (.032) ± 0.15 (.006)		0.35 (.014) ± 0.15 (.006)	0.70 (.028)	Solder Wave or Solder Reflow
0805	2012	2.00 (.079) ± 0.20 (.008)	1.25 (.049) ± 0.20 (.008)		0.50 (0.02) ± 0.25 (.010)	0.75 (.030)	
1206	3216	3.20 (.126) ± 0.20 (.008)	1.60 (.063) ± 0.20 (.008)		0.50 (0.02) ± 0.25 (.010)	N/A	Solder Reflow Only
1210	3225	3.20 (.126) ± 0.20 (.008)	2.50 (.098) ± 0.20 (.008)		0.50 (0.02) ± 0.25 (.010)		
1812	4532	4.50 (.177) ± 0.30 (.012)	3.20 (.126) ± 0.30 (.012)		0.60 (.024) ± 0.35 (.014)		

Applications

Typical applications include circuits with a direct battery or power source connection, critical and safety relevant circuits without (integrated) current limitation and any application that is subject to high levels of board flexure or temperature cycling. Examples include raw power input side filtering (power plane/bus), high current applications (automobile battery line) and circuits that cannot be fused to open. Markets include consumer, medical, industrial (power supply), automotive, aerospace and telecom.

Qualification/Certification

Commercial grade products are subject to internal qualification. Details regarding test methods and conditions are referenced in Table 4, Performance and Reliability.

Automotive grade products meet or exceed the requirements outlined by the Automotive Electronics Council. Details regarding test methods and conditions are referenced in document AEC-Q200, Stress Test Qualification for Passive Components. For additional information regarding the Automotive Electronics Council and AEC-Q200, please visit their website @www.aecouncil.com.

Environmental Compliance

Pb-Free and RoHS compliant (excluding SnPb termination finish option)

Electrical Parameters/Characteristics

Item	Parameters/Characteristics
Operating Temperature Range	-55°C to +125°C
Capacitance Change with Reference to +25°C and 0 Vdc Applied (TCC)	±15%
Aging Rate (Max % Cap Loss/Decade Hour)	3.0%
Dielectric Withstanding Voltage	250% of rated voltage (5 ± 1 seconds and charge/discharge not exceeding 50mA)
Dissipation Factor (DF) Maximum Limits @ 25°C	5%(10V), 3.5%(16V & 25V) and 2.5%(50V to 250V)
Insulation Resistance (IR) Limit @ 25°C	See Insulation Resistance Limit Table (Rated voltage applied for 120 ± 5 secs @ 25°C)

Regarding Aging Rate: Capacitance measurements (including tolerance) are indexed to a referee time of 1000 Hours.

To obtain IR limit, divide $M\Omega \cdot \mu F$ value by the capacitance and compare to $G\Omega$ limit. Select the lower of the two limits.

Capacitance and Dissipation Factor (DF) measured under the following conditions:

1kHz ± 50Hz and 1.0 ± 0.2 Vrms if capacitance ≤ 10μF

120Hz ± 10Hz and 0.5 ± 0.1 Vrms if capacitance > 10μF

Note: When measuring capacitance it is important to ensure the set voltage level is held constant. The HP4284 & Agilent E4980 have a feature known as Automatic Level Control (ALC). The ALC feature should be switched to "ON".

Post Environmental Limits

High Temperature Life, Biased Humidity, Moisture Resistance					
Dielectric	Rated DC Voltage	Capacitance Value	DF (%)	Cap Shift	IR
X7R	>25	All	3.0	± 20%	10% of Initial Limit
	16 / 25		5.0		
	< 16		7.5		

Insulation Resistance Limit Table

EIA Case Size	1000 megohm microfarads or 100GΩ	500 megohm microfarads or 10GΩ
0201	N/A	ALL
0402	< .012μF	≥ .012μF
0603	< .047μF	≥ .047μF
0805	< .047μF	≥ .047μF
1206	< 0.22μF	≥ 0.22μF
1210	< 0.39μF	≥ 0.39μF
1808	ALL	N/A
1812	< 2.2μF	≥ 2.2μF
1825	ALL	N/A
2220	< 10μF	≥ 10μF
2225	ALL	N/A

Table 1A – (FE-CAP), X7R Dielectric, (0402 - 0805 Case Sizes)

Cap	Cap Code	Series			C0402S					C0603S						C0805S									
		Voltage Code			9	8	4	3	5	9	8	4	3	5	1	2	9	8	4	3	5	1	2	A	
		Voltage DC			6.3	10	16	25	50	6.3	10	16	25	50	100	200	6.3	10	16	25	50	100	200	250	
		Cap Tolerance			Product Availability and Chip Thickness Codes - See Table 2 for Chip Thickness Dimensions																				
150 pF	151	J	K	M	BB	BB	BB	BB	BB	CB	CB	CB	CB	CB	CB	CB	DC	DC	DC	DC	DC	DC	DC	DC	
180 pF	181	J	K	M	BB	BB	BB	BB	BB	CB	CB	CB	CB	CB	CB	CB	DC	DC	DC	DC	DC	DC	DC	DC	
220 pF	221	J	K	M	BB	BB	BB	BB	BB	CB	CB	CB	CB	CB	CB	CB	DC	DC	DC	DC	DC	DC	DC	DC	
270 pF	271	J	K	M	BB	BB	BB	BB	BB	CB	CB	CB	CB	CB	CB	CB	DC	DC	DC	DC	DC	DC	DC	DC	
330 pF	331	J	K	M	BB	BB	BB	BB	BB	CB	CB	CB	CB	CB	CB	CB	DC	DC	DC	DC	DC	DC	DC	DC	
390 pF	391	J	K	M	BB	BB	BB	BB	BB	CB	CB	CB	CB	CB	CB	CB	DC	DC	DC	DC	DC	DC	DC	DC	
470 pF	471	J	K	M	BB	BB	BB	BB	BB	CB	CB	CB	CB	CB	CB	CB	DC	DC	DC	DC	DC	DC	DC	DC	
560 pF	561	J	K	M	BB	BB	BB	BB	BB	CB	CB	CB	CB	CB	CB	CB	DC	DC	DC	DC	DC	DC	DC	DC	
680 pF	681	J	K	M	BB	BB	BB	BB	BB	CB	CB	CB	CB	CB	CB	CB	DC	DC	DC	DC	DC	DC	DC	DC	
820 pF	821	J	K	M	BB	BB	BB	BB	BB	CB	CB	CB	CB	CB	CB	CB	DC	DC	DC	DC	DC	DC	DC	DC	
1,000 pF	102	J	K	M	BB	BB	BB	BB	BB	CB	CB	CB	CB	CB	CB	CB	DC	DC	DC	DC	DC	DC	DC	DC	
1,200 pF	122	J	K	M						CB	CB	CB	CB	CB	CB	CB	DC	DC	DC	DC	DC	DC	DC	DC	
1,500 pF	152	J	K	M						CB	CB	CB	CB	CB	CB	CB	DC	DC	DC	DC	DC	DC	DC	DC	
1,800 pF	182	J	K	M						CB	CB	CB	CB	CB	CB	CB	DC	DC	DC	DC	DC	DC	DC	DC	
2,200 pF	222	J	K	M						CB	CB	CB	CB	CB	CB	CB	DC	DC	DC	DC	DC	DC	DC	DC	
2,700 pF	272	J	K	M						CB	CB	CB	CB	CB	CB	CB	DC	DC	DC	DC	DC	DC	DC	DC	
3,300 pF	332	J	K	M						CB	CB	CB	CB	CB	CB	CB	DC	DC	DC	DC	DC	DC	DC	DC	
3,900 pF	392	J	K	M						CB	CB	CB	CB	CB	CB	CB	DC	DC	DC	DC	DC	DC	DC	DC	
4,700 pF	472	J	K	M						CB	CB	CB	CB	CB	CB	CB	DC	DC	DC	DC	DC	DC	DC	DC	
5,600 pF	562	J	K	M						CB	CB	CB	CB	CB	CB	CB	DC	DC	DC	DC	DC	DC	DC	DC	
6,800 pF	682	J	K	M						CB	CB	CB	CB	CB	CB	CB	DC	DC	DC	DC	DC	DC	DC	DC	
8,200 pF	822	J	K	M						CB	CB	CB	CB	CB	CB	CB	DC	DC	DC	DC	DC	DC	DC	DC	
10,000 pF	103	J	K	M						CB	CB	CB	CB	CB	CB	CB	DC	DC	DC	DC	DC	DC	DC	DC	
12,000 pF	123	J	K	M						CB	CB	CB	CB	CB	CB	CB	DC	DC	DC	DC	DC	DC	DC	DC	
15,000 pF	153	J	K	M						CB	CB	CB	CB	CB	CB	CB	DC	DC	DC	DC	DC	DC	DC	DC	
18,000 pF	183	J	K	M						CB	CB	CB	CB	CB	CB	CB	DC	DC	DC	DC	DC	DC	DD		
22,000 pF	223	J	K	M						CB	CB	CB	CB	CB	CB	CB	DC	DC	DC	DC	DC	DC	DD		
27,000 pF	273	J	K	M													DC	DC	DC	DC	DC	DC			
33,000 pF	333	J	K	M													DC	DC	DC	DC	DC	DC			
39,000 pF	393	J	K	M													DC	DC	DC	DC	DC	DC			
47,000 pF	473	J	K	M													DC	DC	DC	DC	DC	DC			
56,000 pF	563	J	K	M													DD	DD	DD	DD	DD	DD			
68,000 pF	683	J	K	M													DD	DD	DD	DD	DD	DD			
82,000 pF	823	J	K	M													DG	DG	DG	DG	DG	DG			
0.10 µF	104	J	K	M													DG	DG	DG	DG	DG	DG			
Cap	Cap Code	Voltage DC			6.3	10	16	25	50	6.3	10	16	25	50	100	200	6.3	10	16	25	50	100	200	250	
		Voltage Code			9	8	4	3	5	9	8	4	3	5	1	2	9	8	4	3	5	1	2	A	
		Series			C0402S					C0603S						C0805S									

Table 1B – (FE-CAP), X7R Dielectric, (1206 - 1812 Case Sizes)

Cap	Cap Code	Series			C1206S								C1210S								C1812S							
		Voltage Code			9	8	4	3	5	1	2	A	9	8	4	3	5	1	2	A	9	8	4	3	5			
		Voltage DC			6.3	10	16	25	50	100	200	250	6.3	10	16	25	50	100	200	250	6.3	10	16	25	50			
Cap Tolerance		Product Availability and Chip Thickness Codes - See Table 2 for Chip Thickness Dimensions																										
1,000 pF	102	J	K	M	EB	EB	EB	EB	EB	EB	EB	EB																
1,200 pF	122	J	K	M	EB	EB	EB	EB	EB	EB	EB	EB																
1,500 pF	152	J	K	M	EB	EB	EB	EB	EB	EB	EB	EB																
1,800 pF	182	J	K	M	EB	EB	EB	EB	EB	EB	EB	EB																
2,200 pF	222	J	K	M	EB	EB	EB	EB	EB	EB	EB	EB	FB	FB	FB	FB	FB	FB	FB									
2,700 pF	272	J	K	M	EB	EB	EB	EB	EB	EB	EB	EB	FB	FB	FB	FB	FB	FB	FB									
3,300 pF	332	J	K	M	EB	EB	EB	EB	EB	EB	EB	EB	FB	FB	FB	FB	FB	FB	FB									
3,900 pF	392	J	K	M	EB	EB	EB	EB	EB	EB	EB	EB	FB	FB	FB	FB	FB	FB	FB									
4,700 pF	472	J	K	M	EB	EB	EB	EB	EB	EB	EB	EB	FB	FB	FB	FB	FB	FB	FB									
5,600 pF	562	J	K	M	EB	EB	EB	EB	EB	EB	EB	EB	FB	FB	FB	FB	FB	FB	FB									
6,800 pF	682	J	K	M	EB	EB	EB	EB	EB	EB	EB	EB	FB	FB	FB	FB	FB	FB	FB	GB	GB	GB	GB	GB				
8,200 pF	822	J	K	M	EB	EB	EB	EB	EB	EB	EB	EB	FB	FB	FB	FB	FB	FB	FB	GB	GB	GB	GB	GB				
10,000 pF	103	J	K	M	EB	EB	EB	EB	EB	EB	EB	EB	FB	FB	FB	FB	FB	FB	FB	GB	GB	GB	GB	GB				
12,000 pF	123	J	K	M	EB	EB	EB	EB	EB	EB	EB	EB	FB	FB	FB	FB	FB	FB	FB	GB	GB	GB	GB	GB				
15,000 pF	153	J	K	M	EB	EB	EB	EB	EB	EB	EB	EB	FB	FB	FB	FB	FB	FB	FB	GB	GB	GB	GB	GB				
18,000 pF	183	J	K	M	EB	EB	EB	EB	EB	EB	EB	EB	FB	FB	FB	FB	FB	FB	FB	GB	GB	GB	GB	GB				
22,000 pF	223	J	K	M	EB	EB	EB	EB	EB	EB	EB	EB	FB	FB	FB	FB	FB	FB	FB	GB	GB	GB	GB	GB				
27,000 pF	273	J	K	M	EB	EB	EB	EB	EB	EB	EB	EB	FB	FB	FB	FB	FB	FB	FB	GB	GB	GB	GB	GB				
33,000 pF	333	J	K	M	EB	EB	EB	EB	EB	EB	EB	EB	FB	FB	FB	FB	FB	FB	FB	GB	GB	GB	GB	GB				
39,000 pF	393	J	K	M	EB	EB	EB	EB	EB	EB	EC	EB	FB	FB	FB	FB	FB	FB	FB	GB	GB	GB	GB	GB				
47,000 pF	473	J	K	M	EB	EB	EB	EB	EB	EB	EC	EB	FB	FB	FB	FB	FB	FB	FC	GB	GB	GB	GB	GB				
56,000 pF	563	J	K	M	EB	EB	EB	EB	EB	EB	EB	EB	FB	FB	FB	FB	FB	FB	FC	GB	GB	GB	GB	GB				
68,000 pF	683	J	K	M	EB	EB	EB	EB	EB	EB	EB	EB	FB	FB	FB	FB	FB	FB	FC	GB	GB	GB	GB	GB				
82,000 pF	823	J	K	M	EB	EB	EB	EB	EB	EB	EB	EB	FB	FB	FB	FB	FB	FB	FC	GB	GB	GB	GB	GB				
0.10 µF	104	J	K	M	EB	EB	EB	EB	EB	EB	EB	EB	FB	FB	FB	FB	FB	FB	FD	GB	GB	GB	GB	GB				
0.12 µF	124	J	K	M	EC	EC	EC	EC	EC				FB	FB	FB	FB	FB			GB	GB	GB	GB	GB				
0.15 µF	154	J	K	M									FC	FC	FC	FC	FC			GB	GB	GB	GB	GB				
0.18 µF	184	J	K	M									FC	FC	FC	FC	FC			GB	GB	GB	GB	GB				
0.22 µF	224	J	K	M									FC	FC	FC	FC	FC			GB	GB	GB	GB	GB				
Cap	Cap Code	Voltage DC			6.3	10	16	25	50	100	200	250	C1210S								C1812S							
		Voltage Code			9	8	4	3	5	1	2	A	9	8	4	3	5	1	2	A	9	8	4	3	5			
		Series			C1206S								C1210S								C1812S							

Flexible Termination System (FT-CAP) X7R Dielectric, 6.3VDC-250VDC (Commercial Grade & Automotive Grade)

Overview

KEMET's Flexible Termination (FT-CAP) multilayer ceramic capacitor in X7R dielectric incorporates a unique, flexible termination system that is integrated with KEMET's standard termination materials. A conductive silver epoxy is utilized between the base metal and nickel barrier layers of KEMET's standard termination system in order to establish pliability while maintaining terminal strength, solderability and electrical performance. This technology was developed in order to address the primary failure mode of MLCCs—flex cracks, which are typically the result of excessive shear stresses produced during board flexure or thermal cycling. Flexible termination technology directs board flex stress away from the ceramic body and into the termination area, therefore mitigating flex cracks which can result in low IR or short circuit failures.

Although this technology does not eliminate the potential for mechanical damage that may propagate during extreme environmental and handling conditions, it does provide

superior flex performance over standard termination systems. Manufactured in state of the art ISO/TS 16949:2002 certified facilities, the FT-CAP complements KEMET's Open Mode, Floating Electrode (FE-CAP), Floating Electrode with Flexible Termination (FF-CAP) and KEMET Power Solutions (KPS) product lines by providing a complete portfolio of flex mitigation solutions.

Combined with the stability of an X7R dielectric and designed to accommodate all capacitance requirements, these flex-robust devices are RoHS-compliant, offer up to 5mm of flex-bend capability and exhibit a predictable change in capacitance with respect to time and voltage. Capacitance change with reference to ambient temperature is limited to $\pm 15\%$ from -55°C to $+125^{\circ}\text{C}$.

In addition to commercial grade, automotive grade devices are available which meet the demanding Automotive Electronics Council's AEC-Q200 qualification requirements .

Benefits

- -55°C to $+125^{\circ}\text{C}$ operating temperature range
- Superior flex performance (up to 5mm)
- High capacitance flex mitigation
- Pb-Free and RoHS compliant
- EIA 0603, 0805, 1206, 1210, 1808, 1812, 2220 and 2225 case sizes
- DC voltage ratings of 6.3V, 10V, 16V, 25V, 50V, 100V, 200V and 250V
- Capacitance offerings ranging from 180pF to 22 μF
- Available capacitance tolerances of $\pm 5\%$, $\pm 10\%$ and $\pm 20\%$

- Non-polar device, minimizing installation concerns
- 100% pure matte tin-plated termination finish allowing for excellent solderability
- SnPb termination finish option available upon request (5% min)
- Commercial and Automotive (AEC-Q200) grades available

**FLEXIBLE
 FT-CAP
 TERMINATION**

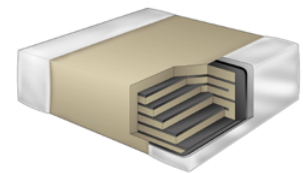

Ordering Information

C	1206	X	106	K	4	R	A	C	AUTO
Ceramic	Case Size (L" x W")	Specification/ Series	Capacitance Code (pF)	Capacitance Tolerance	Voltage	Dielectric	Failure Rate/ Design	Termination Finish ¹	Packaging/Grade (C-Spec) ²
	0603 0805 1206 1210 1808 1812 1825 2220 2225	X = Flexible Termination	2 Sig. Digits + Number of Zeros	J = $\pm 5\%$ K = $\pm 10\%$ M = $\pm 20\%$	9 = 6.3V 8 = 10V 4 = 16V 3 = 25V 5 = 50V 1 = 100V 2 = 200V A = 250V	R = X7R	A = N/A	C = 100% Matte Sn L = SnPb (5% min)	Blank = Bulk TU = 7" Reel Unmarked TM = 7" Reel Marked AUTO = Automotive Grade 7" Reel Unmarked

¹ Additional termination finish options may be available. Contact KEMET for details.

² Additional reeling or packaging options may be available. Contact KEMET for details.

Dimensions – Millimeters (Inches)

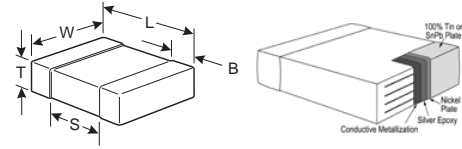

EIA Size Code	Metric Size Code	L Length	W Width	T Thickness	B Bandwidth	S Separation Min.	Mounting Technique
0603	1608	1.60 (.063) +0.20 (.008) / -0.10 (.004)	0.80 (.032) ± 0.15 (.006)	See Table 2 for Thickness	0.45 (.018) +0.05 (.002) / -0.15 (.006)	0.50 (.020)	Solder Wave or Solder Reflow
0805	2012	2.10 (.083) +0.30 (.012) / -0.20 (.008)	1.25 (.049) ± 0.20 (.008)		0.50 (.02) +0.10 (.004) / -0.25 (.010)	0.70 (.028)	
1206	3216	3.30 (.130) ± 0.40 (.016)	1.60 (.063) ± 0.20 (.008)		0.60 (.024) ± 0.25 (.010)	N/A	Solder Reflow Only
1210	3225	3.30 (.130) ± 0.40 (.016)	2.50 (.098) ± 0.20 (.008)		0.60 (.024) ± 0.25 (.010)		
1808	4520	4.70 (.185) ± 0.50 (.020)	2.00 (.079) ± 0.20 (.008)		0.70 (.028) ± 0.35 (.014)		
1812	4532	4.50 (.178) ± 0.40 (.016)	3.20 (.126) ± 0.30 (.012)		0.70 (.028) ± 0.35 (.014)		
1825	4564	4.60 (.181) ± 0.40 (.016)	6.40 (.252) ± 0.40 (.016)		0.70 (.028) ± 0.35 (.014)		
2220	5650	5.90 (.232) ± 0.75 (.030)	5.00 (.197) ± 0.40 (.016)		0.70 (.028) ± 0.35 (.014)		
2225	5664	5.90 (.232) ± 0.75 (.030)	6.40 (.248) ± 0.40 (.016)		0.70 (.028) ± 0.35 (.014)		

Applications

Typical applications include circuits with a direct battery or power source connection, critical and safety relevant circuits without (integrated) current limitation and any application that is subject to high levels of board flexure or temperature cycling. Examples include raw power input side filtering (power plane/bus), high current applications (automobile battery line) and circuits that cannot be fused to open. Markets include consumer, medical, industrial (power supply), automotive, aerospace and telecom.

Qualification/Certification

Commercial grade products are subject to internal qualification. Details regarding test methods and conditions are referenced in Table 4, Performance and Reliability.

Automotive grade products meet or exceed the requirements outlined by the Automotive Electronics Council. Details regarding test methods and conditions are referenced in document AEC-Q200, Stress Test Qualification for Passive Components. For additional information regarding the Automotive Electronics Council and AEC-Q200, please visit their website @www.aecouncil.com.

Environmental Compliance

Pb-Free and RoHS compliant (excluding SnPb termination finish option)

Electrical Parameters/Characteristics

Item	Parameters/Characteristics
Operating Temperature Range	-55°C to +125°C
Capacitance Change with Reference to +25°C and 0 Vdc Applied (TCC)	±15%
Aging Rate (Max % Cap Loss/Decade Hour)	3.0%
Dielectric Withstanding Voltage	250% of rated voltage (5 ± 1 seconds and charge/discharge not exceeding 50mA)
Dissipation Factor (DF) Maximum Limits @ 25°C	5%(10V), 3.5%(16V & 25V) and 2.5%(50V to 250V)
Insulation Resistance (IR) Limit @ 25°C	See Insulation Resistance Limit Table (Rated voltage applied for 120 ± 5 secs @ 25°C)

Regarding Aging Rate: Capacitance measurements (including tolerance) are indexed to a referee time of 1000 hours.

To obtain IR limit, divide $M\Omega\text{-}\mu\text{F}$ value by the capacitance and compare to $G\Omega$ limit. Select the lower of the two limits.

Capacitance and Dissipation Factor (DF) measured under the following conditions:

1kHz ± 50Hz and 1.0 ± 0.2 Vrms if capacitance ≤ 10μF

120Hz ± 10Hz and 0.5 ± 0.1 Vrms if capacitance > 10μF

Note: When measuring capacitance it is important to ensure the set voltage level is held constant. The HP4284 & Agilent E4980 have a feature known as Automatic Level Control (ALC). The ALC feature should be switched to "ON".

Post Environmental Limits

High Temperature Life, Biased Humidity, Moisture Resistance					
Dielectric	Rated DC Voltage	Capacitance Value	DF (%)	Cap Shift	IR
X7R	>25	All	3.0	± 20%	10% of Initial Limit
	16 / 25		5.0		
	< 16		7.5		

Insulation Resistance Limit Table

EIA Case Size	1000 megohm microfarads or 100GΩ	500 megohm microfarads or 10GΩ
0201	N/A	ALL
0402	< .012μF	≥ .012μF
0603	< .047μF	≥ .047μF
0805	< .047μF	≥ .047μF
1206	< 0.22μF	≥ 0.22μF
1210	< 0.39μF	≥ 0.39μF
1808	ALL	N/A
1812	< 2.2μF	≥ 2.2μF
1825	ALL	N/A
2220	< 10μF	≥ 10μF
2225	ALL	N/A

Table 1B – (FT-CAP), X7R Dielectric, (1808 - 2225 Case Sizes) con't

Cap	Cap Code	Series	C1808X				C1812X				C1825X				C2220X					C2225X								
		Voltage Code	5	1	2	A	3	5	1	2	A	5	1	2	A	3	5	1	2	A	5	1	2	A				
		Voltage DC	50	100	200	250	25	50	100	200	250	50	100	200	250	25	50	100	200	250	50	100	200	250				
		Cap Tolerance	Product Availability and Chip Thickness Codes - See Table 2 for Chip Thickness Dimensions																									
1.5 µF	155	J	K	M											HC					JC	JC				KC			
1.8 µF	185	J	K	M											HD					JD	JD				KD			
2.2 µF	225	J	K	M											HF					JF	JF				KD			
2.7 µF	275	J	K	M																								
3.3 µF	335	J	K	M																								
3.9 µF	395	J	K	M																								
4.7 µF	475	J	K	M				GK	GK																			
5.6 µF	565	J	K	M																								
6.8 µF	685	J	K	M																								
8.2 µF	825	J	K	M																								
10 µF	106	J	K	M				GK												JF	JO							
12 µF	126	J	K	M																								
15 µF	156	J	K	M																JO								
18 µF	186	J	K	M																JO								
22 µF	226	J	K	M																JO								
Cap	Cap Code	Voltage DC	50	100	200	250	25	50	100	200	250	50	100	200	250	25	50	100	200	250	50	100	200	250				
		Voltage Code	5	1	2	A	3	5	1	2	A	5	1	2	A	3	5	1	2	A	5	1	2	A				
		Series	C1808X				C1812X				C1825X				C2220X					C2225X								

High Voltage with Flexible Termination System (HV FT-CAP) X7R Dielectric, 500VDC-3000VDC (Commercial & Automotive Grade)

Overview

KEMET's High Voltage with Flexible Termination (HV FT-CAP) surface mount MLCCs in X7R dielectric combine high voltage and flexible termination technologies. Featuring a 125°C maximum operating temperature and considered "temperature stable," these devices address the primary failure mode of MLCCs—flex cracks, which are typically the result of excessive shear stresses produced during board flexure or thermal cycling. Utilizing a conductive silver epoxy between the base metal and nickel barrier layers of KEMET's standard termination system, flexible termination technology directs board flex stress away from the ceramic body and into the termination area, therefore mitigating flex cracks which can result in low IR or short circuit failures. Although flexible termination technology does not eliminate the potential for mechanical damage that may propagate during extreme environmental and handling conditions, it does provide superior flex performance over standard termination systems.

The HV FT-CAP offers low leakage current, exhibits low ESR at high frequencies and finds conventional use as snubbers or filters in applications such as switching power supplies and lighting

ballasts. Their exceptional performance at high frequencies has made them a preferred choice of design engineers worldwide. In addition to their use in power supplies, these capacitors are widely used in industries related to automotive(hybrid), telecommunications, medical, military, aerospace, semiconductors and test/diagnostic equipment.

Combined with the stability of an X7R dielectric and designed to accommodate all capacitance requirements, these flex-robust devices are RoHS-compliant, offer up to 5mm of flex-bend capability and exhibit a predictable change in capacitance with respect to time and voltage. Capacitance change with reference to ambient temperature is limited to ±15% from -55°C to +125°C.

KEMET's high voltage surface mount MLCCs are manufactured in state of the art ISO/TS 16949:2002 certified facilities and are available in both commercial and automotive grades. Automotive grade devices meet the demanding Automotive Electronics Council's AEC-Q200 qualification requirements.

HIGH VOLTAGE
FLEXIBLE
FTCAP
TERMINATION

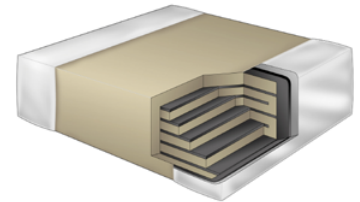

Ordering Information

C	1210	X	473	K	C	R	A	C	TU
Ceramic	Case Size (L" x W")	Specification/ Series	Capacitance Code (pF)	Capacitance Tolerance	Voltage	Dielectric	Failure Rate/ Design	Termination Finish ¹	Packaging/Grade (C-Spec) ²
	0805 1206 1210 1808 1812 1825 2220 2225	X = Flexible Termination	2 Sig. Digits + Number of Zeros	J = ±5% K = ±10% M = ±20%	C = 500V B = 630V D = 1000V F = 1500V G = 2000V Z = 2500V H = 3000V	R = X7R	A = N/A	C = 100% Matte Sn L = SnPb (5% min)	Blank = Bulk TU = 7" Reel Unmarked TM = 7" Reel Marked AUTO = Automotive Grade 7" Reel Unmarked

¹ SnPb termination finish option is not available on automotive grade product.

¹ Additional termination finish options may be available. Contact KEMET for details.

² Additional reeling or packaging options may be available. Contact KEMET for details.

Dimensions – Millimeters (Inches)

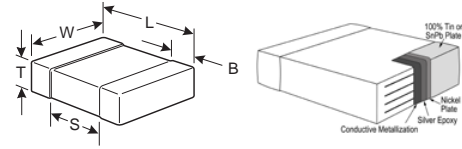

EIA Size Code	Metric Size Code	L Length	W Width	T Thickness	B Bandwidth	S Separation Min.	Mounting Technique
0805	2012	2.10 (.083) +0.30 (.012) / -0.20 (.008)	1.25 (.049) ± 0.20 (.008)	See Table 2 for Thickness	0.50 (0.02) +0.10(.004)/ -0.25 (.010)	0.70 (.028)	Solder Wave or Solder Reflow
1206	3216	3.30 (.130) ± 0.40 (.016)	1.60 (.063) ± 0.20 (.008)		0.60 (.024) ± 0.25 (.010)	N/A	
1210	3225	3.30 (.130) ± 0.40 (.016)	2.50 (.098) ± 0.20 (.008)		0.60 (.024) ± 0.25 (.010)		
1808	4520	4.70 (.185) ± 0.50 (.020)	2.00 (.079) ± 0.20 (.008)		0.70 (.028) ± 0.35 (.014)		
1812	4532	4.50 (.178) ± 0.40 (.016)	3.20 (.126) ± 0.30 (.012)		0.70 (.028) ± 0.35 (.014)		
1825	4564	4.60 (.181) ± 0.40 (.016)	6.40 (.252) ± 0.40 (.016)		0.70 (.028) ± 0.35 (.014)		
2220	5650	5.90 (.232) ± 0.75 (.030)	5.00 (.197) ± 0.40 (.016)		0.70 (.028) ± 0.35 (.014)		
2225	5664	5.90 (.232) ± 0.75 (.030)	6.40 (.248) ± 0.40 (.016)		0.70 (.028) ± 0.35 (.014)		Solder Reflow Only

Benefits

- -55°C to +125°C operating temperature range
- Superior flex performance (up to 5mm)
- Pb-Free and RoHS compliant
- EIA 0805, 1206, 1210, 1808, 1812, 1825, 2220 and 2225 case sizes
- DC voltage ratings of 500V, 630V, 1KV, 1.5KV, 2KV, 2.5KV and 3KV
- Capacitance offerings ranging from 62pF to 0.27µF
- Available capacitance tolerances of ±5%, ±10% or ±20%.
- Low ESR and ESL
- Non-polar device, minimizing installation concerns
- Commercial & Automotive (AEC-Q200) grades available
- 100% pure matte tin-plated termination finish allowing for excellent solderability
- SnPb plated termination finish option available upon request (5% min)

Applications

Typical applications include switch mode power supplies (input filters, resonators, tank circuits, snubber circuits, output filters), high voltage coupling and DC blocking, lighting ballasts, voltage multiplier circuits, DC/DC converters and coupling capacitors in Ćuk converters. Markets include power supply, LCD fluorescent backlight ballasts, HID lighting, telecom equipment, industrial and medical equipment/control, LAN/WAN interface, analog and digital modems, and automotive. X7R dielectrics are not designed for AC line filtering or pulse applications.

Qualification/Certification

Commercial grade products are subject to internal qualification. Details regarding test methods and conditions are referenced in Table 4, Performance and Reliability.

Automotive grade products meet or exceed the requirements outlined by the Automotive Electronics Council. Details regarding test methods and conditions are referenced in document AEC-Q200, Stress Test Qualification for Passive Components. For additional information regarding the Automotive Electronics Council and AEC-Q200, please visit their website @www.aecouncil.com.

Environmental Compliance

Pb-Free and RoHS compliant (excluding SnPb termination finish option)

Electrical Parameters/Characteristics

Item	Parameters/Characteristics
Operating Temperature Range	-55°C to +125°C
Capacitance Change with Reference to +25°C and 0 Vdc Applied (TCC)	±15%
Aging Rate (Max % Cap Loss/Decade Hour)	3.0%
Dielectric Withstanding Voltage	150% of rated voltage for voltage rating of < 1000V 120% of rated voltage for voltage rating of ≥ 1000V (5 ± 1 seconds and charge/discharge not exceeding 50mA)
Dissipation Factor (DF) Maximum Limit @ 25°C	2.5%
Insulation Resistance (IR) Limit @ 25°C	1000 megohm microfarads or 100GΩ (Rated voltage applied for 120 ± 5 secs @ 25°C)

Regarding Aging Rate: Capacitance measurements (including tolerance) are indexed to a referee time of 1000 Hours.

To obtain IR limit, divide MΩ-μF value by the capacitance and compare to GΩ limit. Select the lower of the two limits.

Capacitance and Dissipation Factor (DF) measured under the following conditions:

1kHz ± 50Hz and 1.0 ± 0.2 Vrms if capacitance ≤ 10μF

120Hz ± 10Hz and 0.5 ± 0.1 Vrms if capacitance > 10μF

Note: When measuring capacitance it is important to ensure the set voltage level is held constant. The HP4284 & Agilent E4980 have a feature known as Automatic Level Control (ALC). The ALC feature should be switched to "ON".

Post Environmental Limits

High Temperature Life, Biased Humidity, Moisture Resistance					
Dielectric	Rated DC Voltage	Capacitance Value	DF (%)	Cap Shift	IR
X7R	>25	All	3.0	± 20%	10% of Initial Limit
	16 / 25		5.0		
	< 16		7.5		

Table 1A – (HV FT-CAP), X7R Dielectric, (0805 - 1812 Case Sizes)

Cap	Cap Code	Series	C0805					C1206					C1210					C1808						C1812						
		Voltage Code	C	B	D	C	B	D	F	G	C	B	D	F	G	C	B	D	F	G	Z	H	C	B	D	F	G	Z	H	
		Voltage DC	500	630	1000	500	630	1000	1500	2000	500	630	1000	1500	2000	500	630	1000	1500	2000	2500	3000	500	630	1000	1500	2000	2500	3000	
		Cap Tolerance	Product Availability and Chip Thickness Codes - See Table 2 for Chip Thickness Dimensions																											
56 pF	560	J K M																												
62 pF	620	J K M	DG	DG	DG																									
68 pF	680	J K M	DG	DG	DG																									
75 pF	750	J K M	DG	DG	DG	EG	EG	EG	EG	EG																				
82 pF	820	J K M	DG	DG	DG	EG	EG	EG	EG	EG																				
91 pF	910	J K M	DG	DG	DG	EG	EG	EG	EG	EG																				
100 pF	101	J K M	DG	DG	DG	EG	EG	EG	EG	EG																				
110 pF	111	J K M	DG	DG	DG	EF	EF	EF	EF	EG																				
120 pF	121	J K M	DG	DG	DG	EF	EF	EF	EF	EG																				
130 pF	131	J K M	DG	DG	DG	EF	EF	EF	EF	EG	FL	FL	FL	FL	FL	LA	LA	LA	LA	LB	LB	LB	LB							
150 pF	151	J K M	DG	DG	DG	EF	EF	EF	EF	EG	FL	FL	FL	FL	FL	LA	LA	LA	LA	LB	LB	LB	LB	GK	GK	GK	GK	GK	GK	GK
180 pF	181	J K M	DG	DG	DG	EF	EF	EF	EF	EG	FL	FL	FL	FL	FL	LA	LA	LA	LA	LB	LB	LB	LB	GK	GK	GK	GK	GK	GK	GK
220 pF	221	J K M	DG	DG	DG	EF	EF	EF	EF	EG	FL	FL	FL	FL	FL	LA	LA	LA	LA	LB	LB	LB	LB	GK	GK	GK	GK	GK	GK	GK
270 pF	271	J K M	DG	DG	DG	EF	EF	EF	EF	EG	FL	FL	FL	FL	FL	LA	LA	LA	LA	LB	LB	LB	LC	GK	GK	GK	GK	GK	GK	GK
330 pF	331	J K M	DG	DG	DG	EF	EF	EF	EF	EG	FL	FL	FL	FL	FL	LA	LA	LA	LA	LB	LB	LB	LC	GK	GK	GK	GK	GK	GK	GK
390 pF	391	J K M	DG	DG	DG	EF	EF	EF	EF	EG	FL	FL	FL	FL	FL	LA	LA	LA	LA	LB	LB	LB	LC	GK	GK	GK	GK	GK	GK	GK
470 pF	471	J K M	DG	DG	DG	EF	EF	EF	EF	EG	FL	FL	FL	FL	FL	LA	LA	LA	LA	LB	LB	LB	LC	GK	GK	GH	GH	GH	GH	GK
560 pF	561	J K M	DG	DG	DG	EF	EF	EF	EF	EG	FL	FL	FL	FL	FL	LA	LA	LA	LA	LB	LB	LB	LC	GH	GH	GH	GH	GH	GK	GK
680 pF	681	J K M	DG	DG	DG	EF	EF	EF	EF	EG	FL	FL	FL	FL	FL	LA	LA	LA	LA	LB	LB	LB	LC	GH	GH	GH	GH	GH	GK	GK
820 pF	821	J K M	DG	DG	DG	EF	EF	EF	EF	EG	FL	FL	FL	FL	FL	LA	LA	LA	LA	LB	LB	LB	LC	GH	GH	GH	GH	GH	GK	GK
1,000 pF	102	J K M	DG	DG	DG	EF	EF	EF	EF	EG	FL	FL	FL	FL	FL	LA	LA	LA	LA	LB	LB	LB	LC	GH	GH	GH	GH	GH	GK	GK
1,200 pF	122	J K M	DG	DG	DG	EF	EF	EF	EG	EG	FL	FL	FL	FL	FM	LB	LB	LB	LB	LC				GH	GH	GH	GH	GH	GK	GK
1,500 pF	152	J K M	DG	DG	DG	EF	EF	EF	EG	EG	FL	FL	FL	FL	FM	LA	LA	LA	LB	LC				GH	GH	GH	GH	GH		
1,800 pF	182	J K M	DG	DG	DG	EF	EF	EF	EG	EG	FL	FL	FL	FL	FM	LA	LA	LA	LB	LC				GH	GH	GH	GH	GH		
2,000 pF	202	J K M	DG	DG	DG	EF	EF	EF	EG	EG	FL	FL	FL	FL	FM	LA	LA	LA	LB	LC				GH	GH	GH	GH	GH		
2,200 pF	222	J K M	DG	DG	DG	EF	EF	EF	EG	EG	FL	FL	FL	FL	FM	LA	LA	LA	LB	LC				GH	GH	GH	GH	GH		
2,700 pF	272	J K M	DG	DG	DG	EF	EF	EF	EG	EG	FL	FL	FL	FL	FM	LA	LA	LA	LB	LC				GH	GH	GH	GH	GK		
3,300 pF	332	J K M	DG	DG	DG	EF	EF	EF	EG	EG	FL	FL	FL	FL	FM	LA	LA	LA	LB					GH	GH	GH	GH	GK		
3,900 pF	392	J K M	DG	UD	UD	EF	EF	EF	EG	EG	FL	FL	FL	FL	FK	LA	LA	LA	LB					GH	GH	GH	GH	GK		
4,700 pF	472	J K M	DG	UD	UD	EF	EF	EF	EG	EG	FL	FL	FL	FL	FK	LA	LA	LA	LB					GH	GH	GH	GH			
5,600 pF	562	J K M	DG	UD	UD	EF	EF	EF			FL	FL	FL	FM		LA	LB	LB	LC					GH	GH	GH	GK			
6,800 pF	682	J K M	DG	UD	UD	EG	EG	EG			FL	FL	FL	FM		LA	LB	LB	LC					GH	GH	GH	GK			
8,200 pF	822	J K M	DG	UD	UD	EG	EG	EG			FL	FL	FL	FK		LA	LB	LB	LC					GH	GH	GH	GK			
10,000 pF	103	J K M	UD			EG	EG	EG			FL	FL	FL	FK		LA	LB	LB	LC					GH	GH	GH	GK			
12,000 pF	123	J K M	UD			EG	UD	UD			FL	FL	FL	FK		LA	LC	LC						GH	GK	GK	GK			
15,000 pF	153	J K M				EG	UD	UD			FL	FL	FL			LA	LC	LC						GH	GK	GK				
18,000 pF	183	J K M				UD	UD	UD			FL	FL	FL			LA	UD	UD						GH	GK	GK				
22,000 pF	223	J K M				UD	UD	UD			FL	FM	FM			LA	UD	UD						GH	GK	GK				
27,000 pF	273	J K M				UD	UD	UD			FM	FK	FK			LA	UD	UD						GH	UD	UD				
33,000 pF	333	J K M				UD	UD				FM	UD	UD			LC	UD	UD						GH	UD	UD				
39,000 pF	393	J K M				UD					FK	UD	UD			LC	UD	UD						GH	UD	UD				
47,000 pF	473	J K M				UD					FK	UD	UD			LC	UD	UD						GH	UD	UD				
56,000 pF	563	J K M				UD					UD	UD	UD			LC	UD	UD						GH	UD	UD				
62,000 pF	623	J K M				UD					UD	UD	UD			UD	UD	UD						GK	UD	UD				
68,000 pF	683	J K M				UD					UD	UD	UD			UD	UD	UD						UD	UD	UD				
82,000 pF	823	J K M				UD					UD	UD				UD	UD							UD	UD	UD				
0.10 μF	104	J K M				UD					UD	UD				UD	UD							UD	UD	UD				
0.12 μF	124	J K M				UD					UD					UD								UD	UD	UD				
0.15 μF	154	J K M				UD					UD					UD								UD	UD	UD				
0.18 μF	184	J K M				UD					UD					UD								UD	UD	UD				
0.22 μF	224	J K M				UD					UD					UD								UD	UD	UD				
0.27 μF	274	J K M				UD					UD					UD								UD	UD	UD				
0.33 μF	334	J K M				UD					UD					UD								UD	UD	UD				
Cap	Cap Code	Voltage DC	500	630	1000	500	630	1000	1500	2000	500	630	1000	1500	2000	500	630	1000	1500	2000	2500	3000	500	630	1000	1500	2000	2500	3000	
		Voltage Code	C	B	D	C	B	D	F	G	C	B	D	F	G	C	B	D	F	G	Z	H	C	B	D	F	G	Z	H	
		Series	C0805					C1206					C1210					C1808						C1812						
		Cap Tolerance	Product Availability and Chip Thickness Codes - See Table 2 for Chip Thickness Dimensions																											

UD = Under Development

KEMET reserves the right to substitute product with an improved temperature characteristic, tighter capacitance tolerance and/or higher voltage capability within the same form factor (configuration and dimensions).

Table 1B – (HV FT-CAP), X7R Dielectric, (1825 - 2225 Case Sizes)

Cap	Cap Code	Series			C1825								C2220								C2225											
		Voltage Code			C	B	D	F	G	Z	H	C	B	D	F	G	Z	H	C	B	D	F	G	Z	H							
		Voltage DC			500	630	1000	1500	2000	2500	3000	500	630	1000	1500	2000	2500	3000	500	630	1000	1500	2000	2500	3000							
		Cap Tolerance			Product Availability and Chip Thickness Codes - See Table 2 for Chip Thickness Dimensions																											
180 pF	181	J	K	M																												
220 pF	221	J	K	M																												
270 pF	271	J	K	M																												
330 pF	331	J	K	M	HG	HG	HG	HG	HG	HG	HG	HG	HG	HG	HG	HG	HG	HG	HG	HG	HG	HG	HG	HG	HG	HG	HG	HG	HG			
390 pF	391	J	K	M	HG	HG	HG	HG	HG	HG	HG	HG	HG	HG	HG	HG	HG	HG	HG	HG	HG	HG	HG	HG	HG	HG	HG	HG	HG			
470 pF	471	J	K	M	HG	HG	HG	HG	HG	HG	HG	HG	HG	HG	HG	HG	HG	HG	HG	HG	HG	HG	HG	HG	HG	HG	HG	HG	HG			
560 pF	561	J	K	M	HG	HG	HG	HG	HG	HG	HG	HG	HG	HG	HG	HG	HG	HG	HG	HG	HG	HG	HG	HG	HG	HG	HG	HG	HG			
680 pF	681	J	K	M	HG	HG	HG	HG	HG	HG	HG	HG	HG	HG	HG	HG	HG	HG	HG	HG	HG	HG	HG	HG	HG	HG	HG	HG	HG			
820 pF	821	J	K	M	HG	HG	HG	HG	HG	HG	HG	HG	HG	HG	HG	HG	HG	HG	HG	HG	HG	HG	HG	HG	HG	HG	HG	HG	HG			
1,000 pF	102	J	K	M	HG	HG	HG	HG	HG	HG	HG	HG	HG	HG	HG	HG	HG	HG	HG	HG	HG	HG	HG	HG	HG	HG	HG	HG	HG			
1,200 pF	122	J	K	M	HG	HG	HG	HG	HG	HG	HG	HG	HG	HG	HG	HG	HG	HG	HG	HG	HG	HG	HG	HG	HG	HG	HG	HG	HG			
1,500 pF	152	J	K	M	HG	HG	HG	HG	HG	HG	HG	HG	HG	HG	HG	HG	HG	HG	HG	HG	HG	HG	HG	HG	HG	HG	HG	HG	HG			
1,800 pF	182	J	K	M	HE	HE	HE	HE	HE	HE	HG	HG	HG	HG	HG	HG	HG	HG	HG	HG	HG	HG	HG	HG	HG	HG	HG	HG	HG			
2,000 pF	202	J	K	M	HE	HE	HE	HE	HE	HE	HG	HG	HG	HG	HG	HG	HG	HG	HG	HG	HG	HG	HG	HG	HG	HG	HG	HG	HG			
2,200 pF	222	J	K	M	HE	HE	HE	HE	HE	HE	HG	HG	HG	HG	HG	HG	HG	HG	HG	HG	HG	HG	HG	HG	HG	HG	HG	HG	HG			
2,700 pF	272	J	K	M	HE	HE	HE	HE	HE	HE	HG	HG	HG	HG	HG	HG	HG	HG	HG	HG	HG	HG	HG	HG	HG	HG	HG	HG	HG			
3,300 pF	332	J	K	M	HE	HE	HE	HE	HE	HE	HG	HG	HG	HG	HG	HG	HG	HG	HG	HG	HG	HG	HG	HG	HG	HG	HG	HG	HG			
3,900 pF	392	J	K	M	HE	HE	HE	HE	HE	HE	HG	HG	HG	HG	HG	HG	HG	HG	HG	HG	HG	HG	HG	HG	HG	HG	HG	HG	HG			
4,700 pF	472	J	K	M	HE	HE	HE	HE	HE	HE	HG	HG	HG	HG	HG	HG	HG	HG	HG	HG	HG	HG	HG	HG	HG	HG	HG	HG	HG			
5,600 pF	562	J	K	M	HE	HE	HE	HE	HE	HE	HG	HG	HG	HG	HG	HG	HG	HG	HG	HG	HG	HG	HG	HG	HG	HG	HG	HG	HG			
6,800 pF	682	J	K	M	HE	HE	HE	HE	HE	HE	HG	HG	HG	HG	HG	HG	HG	HG	HG	HG	HG	HG	HG	HG	HG	HG	HG	HG	HG			
8,200 pF	822	J	K	M	HE	HE	HE	HE	HE	HE	HG	HG	HG	HG	HG	HG	HG	HG	HG	HG	HG	HG	HG	HG	HG	HG	HG	HG	HG			
10,000 pF	103	J	K	M	HE	HE	HE	HE	HE	HE	HG	HG	HG	HG	HG	HG	HG	HG	HG	HG	HG	HG	HG	HG	HG	HG	HG	HG	HG			
12,000 pF	123	J	K	M	HE	HE	HE	HG	HG	HG	HG	HG	HG	HG	HG	HG	HG	HG	HG	HG	HG	HG	HG	HG	HG	HG	HG	HG	HG			
15,000 pF	153	J	K	M	HE	HE	HE	HG	HG	HG	HG	HG	HG	HG	HG	HG	HG	HG	HG	HG	HG	HG	HG	HG	HG	HG	HG	HG	HG			
18,000 pF	183	J	K	M	HE	HE	HE	HG	HG	HG	HG	HG	HG	HG	HG	HG	HG	HG	HG	HG	HG	HG	HG	HG	HG	HG	HG	HG	HG			
22,000 pF	223	J	K	M	HE	HG	HG	HG	HG	HG	HG	HG	HG	HG	HG	HG	HG	HG	HG	HG	HG	HG	HG	HG	HG	HG	HG	HG	HG			
27,000 pF	273	J	K	M	HE	HG	HG	HG	HG	HG	HG	HG	HG	HG	HG	HG	HG	HG	HG	HG	HG	HG	HG	HG	HG	HG	HG	HG	HG			
33,000 pF	333	J	K	M	HE	HG	HG	HG	HG	HG	HG	HG	HG	HG	HG	HG	HG	HG	HG	HG	HG	HG	HG	HG	HG	HG	HG	HG	HG			
39,000 pF	393	J	K	M	HE	HG	HG	HG	HG	HG	HG	HG	HG	HG	HG	HG	HG	HG	HG	HG	HG	HG	HG	HG	HG	HG	HG	HG	HG			
47,000 pF	473	J	K	M	HE	HG	HG	HG	HG	HG	HG	HG	HG	HG	HG	HG	HG	HG	HG	HG	HG	HG	HG	HG	HG	HG	HG	HG	HG			
56,000 pF	563	J	K	M	HE	HG	HG	HG	HG	HG	HG	HG	HG	HG	HG	HG	HG	HG	HG	HG	HG	HG	HG	HG	HG	HG	HG	HG	HG			
62,000 pF	623	J	K	M	HG	HG	HG	HG	HG	HG	HG	HG	HG	HG	HG	HG	HG	HG	HG	HG	HG	HG	HG	HG	HG	HG	HG	HG	HG			
68,000 pF	683	J	K	M	HG	HG	HG	HG	HG	HG	HG	HG	HG	HG	HG	HG	HG	HG	HG	HG	HG	HG	HG	HG	HG	HG	HG	HG	HG			
82,000 pF	823	J	K	M	HG	HG	HG	HG	HG	HG	HG	HG	HG	HG	HG	HG	HG	HG	HG	HG	HG	HG	HG	HG	HG	HG	HG	HG	HG			
0.10 µF	104	J	K	M	HG	HG	HG	HG	HG	HG	HG	HG	HG	HG	HG	HG	HG	HG	HG	HG	HG	HG	HG	HG	HG	HG	HG	HG	HG			
0.12 µF	124	J	K	M	HG	HG	HG	HG	HG	HG	HG	HG	HG	HG	HG	HG	HG	HG	HG	HG	HG	HG	HG	HG	HG	HG	HG	HG	HG			
0.15 µF	154	J	K	M	HG	HG	HG	HG	HG	HG	HG	HG	HG	HG	HG	HG	HG	HG	HG	HG	HG	HG	HG	HG	HG	HG	HG	HG	HG			
0.18 µF	184	J	K	M	HG	HG	HG	HG	HG	HG	HG	HG	HG	HG	HG	HG	HG	HG	HG	HG	HG	HG	HG	HG	HG	HG	HG	HG	HG			
0.22 µF	224	J	K	M	HG	HG	HG	HG	HG	HG	HG	HG	HG	HG	HG	HG	HG	HG	HG	HG	HG	HG	HG	HG	HG	HG	HG	HG	HG			
0.27 µF	274	J	K	M	HG	HG	HG	HG	HG	HG	HG	HG	HG	HG	HG	HG	HG	HG	HG	HG	HG	HG	HG	HG	HG	HG	HG	HG	HG			
0.33 µF	334	J	K	M	HG	HG	HG	HG	HG	HG	HG	HG	HG	HG	HG	HG	HG	HG	HG	HG	HG	HG	HG	HG	HG	HG	HG	HG	HG			
0.39 µF	394	J	K	M	HG	HG	HG	HG	HG	HG	HG	HG	HG	HG	HG	HG	HG	HG	HG	HG	HG	HG	HG	HG	HG	HG	HG	HG	HG			
0.47 µF	474	J	K	M	HG	HG	HG	HG	HG	HG	HG	HG	HG	HG	HG	HG	HG	HG	HG	HG	HG	HG	HG	HG	HG	HG	HG	HG	HG			
0.56 µF	564	J	K	M	HG	HG	HG	HG	HG	HG	HG	HG	HG	HG	HG	HG	HG	HG	HG	HG	HG	HG	HG	HG	HG	HG	HG	HG	HG			
Cap	Cap Code	Voltage DC			500	630	1000	1500	2000	2500	3000	500	630	1000	1500	2000	2500	3000	500	630	1000	1500	2000	2500	3000	500	630	1000	1500	2000	2500	3000
		Voltage Code			C	B	D	F	G	Z	H	C	B	D	F	G	Z	H	C	B	D	F	G	Z	H	C	B	D	F	G	Z	H
		Series			C1825								C2220								C2225											

KEMET reserves the right to substitute product with an improved temperature characteristic, tighter capacitance tolerance and/or higher voltage capability within the same form factor (configuration and dimensions).

Floating Electrode Design with Flexible Termination System (FF-CAP) X7R Dielectric, 6.3VDC-250VDC (Commercial Grade)

Overview

KEMET's Floating Electrode with Flexible Termination capacitor (FF-CAP) combines two existing KEMET technologies— Floating Electrode and Flexible Termination. The floating electrode component utilizes a cascading internal electrode design configured to form multiple capacitors in series within a single monolithic structure. This unique configuration results in enhanced voltage and ESD performance over standard capacitor designs while allowing for a fail-open condition if mechanically damaged (cracked). The flexible termination component utilizes a conductive silver epoxy between the base metal and nickel barrier layers of KEMET's standard termination system in order to establish pliability while maintaining terminal strength, solderability and electrical performance. Both technologies address the primary failure mode of MLCCs—flex cracks, which are typically the result of excessive shear stresses produced during board

flexure or thermal cycling.

Although neither technology can eliminate the potential for mechanical damage that may propagate during extreme environmental and/or handling conditions, the combination of these two technologies provide the ultimate level of protection against a low IR or short circuit condition. The FF-CAP complements KEMET's Open Mode, Floating Electrode (FE-CAP), Flexible Termination (FT-CAP) and KEMET Power Solutions (KPS) product lines by providing an ultimate fail-safe design optimized for low to mid range capacitance values. These devices exhibit a predictable change in capacitance with respect to time and voltage and boast a minimal change in capacitance with reference to ambient temperature. Capacitance change is limited to $\pm 15\%$ from -55°C to $+125^{\circ}\text{C}$.

Benefits

- -55°C to $+125^{\circ}\text{C}$ operating temperature range
- Superior flex performance (up to 5mm)
- Floating Electrode/fail open design
- Low to mid capacitance flex mitigation
- Pb-Free and RoHS compliant
- EIA 0603, 0805, 1206, 1210, and 1812 case sizes
- DC voltage ratings of 6.3V, 10V, 16V, 25V, 50V, 100V, 200V and 250V
- Capacitance offerings ranging from 180pF to 0.22 μF
- Available capacitance tolerances of $\pm 5\%$, $\pm 10\%$ and $\pm 20\%$
- Non-polar device, minimizing installation concerns
- 100% pure matte tin-plated termination finish allowing for excellent solderability
- SnPb termination finish option available upon request (5% min)

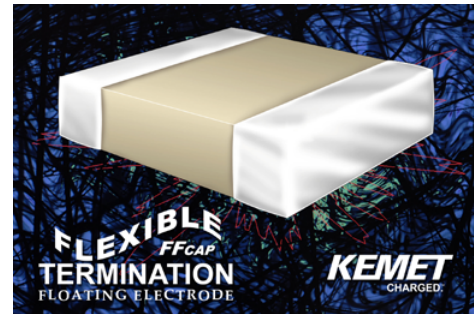

Ordering Information

C	0805	Y	104	K	5	R	A	C	TU
Ceramic	Case Size (L" x W")	Specification/ Series	Capacitance Code (pF)	Capacitance Tolerance	Voltage	Dielectric	Failure Rate/ Design	Termination Finish ¹	Packaging/Grade (C-Spec) ²
	0603 0805 1206 1210 1812	Y = Floating Electrode w/ Flexible Termination	2 Sig. Digits + Number of Zeros	J = $\pm 5\%$ K = $\pm 10\%$ M = $\pm 20\%$	9 = 6.3V 8 = 10V 4 = 16V 3 = 25V 5 = 50V 1 = 100V 2 = 200V A = 250V	R = X7R	A = N/A	C = 100% Matte Sn L = SnPb (5% min)	Blank = Bulk TU = 7" Reel Unmarked TM = 7" Reel Marked

¹ Additional termination finish options may be available. Contact KEMET for details.

² Additional reeling or packaging options may be available. Contact KEMET for details.

Dimensions – Millimeters (Inches)

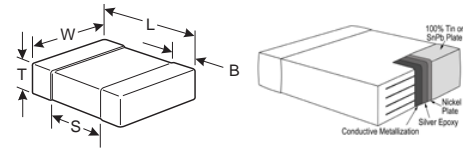

EIA Size Code	Metric Size Code	L Length	W Width	T Thickness	B Bandwidth	S Separation Min.	Mounting Technique
0603	1608	1.60 (.063) +0.20 (.008) / -0.10 (.004)	0.80 (.032) ± 0.15 (.006)	See Table 2 for Thickness	0.45 (.018) +0.05 (.002) / -0.15 (.006)	0.50 (.020)	Solder Wave or Solder Reflow
0805	2012	2.10 (.083) +0.30 (.012) / -0.20 (.008)	1.25 (.049) ± 0.20 (.008)		0.50 (0.02) +0.10(.004) / -0.25 (.010)	0.70 (.028)	
1206	3216	3.20 (.126) ± 0.20 (.008)	1.60 (.063) ± 0.20 (.008)		0.50 (0.02) ± 0.25 (.010)	N/A	Solder Reflow Only
1210	3225	3.20 (.126) ± 0.20 (.008)	2.50 (.098) ± 0.20 (.008)		0.50 (0.02) ± 0.25 (.010)		
1812	4532	4.50 (.177) ± 0.30 (.012)	3.20 (.126) ± 0.30 (.012)		0.60 (.024) ± 0.35 (.014)		

Applications

Typical applications include circuits with a direct battery or power source connection, critical and safety relevant circuits without (integrated) current limitation and any application that is subject to high levels of board flexure or temperature cycling. Examples include raw power input side filtering (power plane/bus), high current applications (automobile battery line) and circuits that cannot be fused to open. Markets include consumer, medical, industrial (power supply), automotive, aerospace and telecom.

Qualification/Certification

Commercial grade products are subject to internal qualification. Details regarding test methods and conditions are referenced in Table 4, Performance and Reliability.

Automotive grade products meet or exceed the requirements outlined by the Automotive Electronics Council. Details regarding test methods and conditions are referenced in document AEC-Q200, Stress Test Qualification for Passive Components. For additional information regarding the Automotive Electronics Council and AEC-Q200, please visit their website @www.aecouncil.com.

Environmental Compliance

Pb-Free and RoHS compliant (excluding SnPb termination finish option)

Electrical Parameters/Characteristics

Item	Parameters/Characteristics
Operating Temperature Range	-55°C to +125°C
Capacitance Change with Reference to +25°C and 0 Vdc Applied (TCC)	±15%
Aging Rate (Max % Cap Loss/Decade Hour)	3.0%
Dielectric Withstanding Voltage	250% of rated voltage (5 ± 1 seconds and charge/discharge not exceeding 50mA)
Dissipation Factor (DF) Maximum Limits @ 25°C	5%(10V), 3.5%(16V & 25V) and 2.5%(50V to 250V)
Insulation Resistance (IR) Limit @ 25°C	See Insulation Resistance Limit Table (Rated voltage applied for 120 ± 5 secs @ 25°C)

Regarding Aging Rate: Capacitance measurements (including tolerance) are indexed to a referee time of 1000 Hours.

To obtain IR limit, divide MΩ-μF value by the capacitance and compare to GΩ limit. Select the lower of the two limits.

Capacitance and Dissipation Factor (DF) measured under the following conditions:

1kHz ± 50Hz and 1.0 ± 0.2 Vrms if capacitance ≤ 10μF

120Hz ± 10Hz and 0.5 ± 0.1 Vrms if capacitance > 10μF

Note: When measuring capacitance it is important to ensure the set voltage level is held constant. The HP4284 & Agilent E4980 have a feature known as Automatic Level Control (ALC). The ALC feature should be switched to "ON".

Post Environmental Limits

High Temperature Life, Biased Humidity, Moisture Resistance					
Dielectric	Rated DC Voltage	Capacitance Value	DF (%)	Cap Shift	IR
X7R	>25	All	3.0	± 20%	10% of Initial Limit
	16 / 25		5.0		
	< 16		7.5		

Insulation Resistance Limit Table

EIA Case Size	1000 megohm microfarads or 100GΩ	500 megohm microfarads or 10GΩ
0201	N/A	ALL
0402	< .012μF	≥ .012μF
0603	< .047μF	≥ .047μF
0805	< .047μF	≥ .047μF
1206	< 0.22μF	≥ 0.22μF
1210	< 0.39μF	≥ 0.39μF
1808	ALL	N/A
1812	< 2.2μF	≥ 2.2μF
1825	ALL	N/A
2220	< 10μF	≥ 10μF
2225	ALL	N/A

Table 1A – (FF-CAP), X7R Dielectric, (0603 - 0805 Case Sizes)

Cap	Cap Code	Series			C0603Y						C0805Y								
		Voltage Code			9	8	4	3	5	1	2	9	8	4	3	5	1	2	A
		Voltage DC			6.3	10	16	25	50	100	200	6.3	10	16	25	50	100	200	250
		Cap Tolerance			Product Availability and Chip Thickness Codes - See Table 2 for Chip Thickness Dimensions														
150 pF	151	J	K	M															
180 pF	181	J	K	M	CB	CB	CB	CB	CB	CB	CB	DC	DC	DC	DC	DC	DC	DC	
220 pF	221	J	K	M	CB	CB	CB	CB	CB	CB	CB	DC	DC	DC	DC	DC	DC	DC	
270 pF	271	J	K	M	CB	CB	CB	CB	CB	CB	CB	DC	DC	DC	DC	DC	DC	DC	
330 pF	331	J	K	M	CB	CB	CB	CB	CB	CB	CB	DC	DC	DC	DC	DC	DC	DC	
390 pF	391	J	K	M	CB	CB	CB	CB	CB	CB	CB	DC	DC	DC	DC	DC	DC	DC	
470 pF	471	J	K	M	CB	CB	CB	CB	CB	CB	CB	DC	DC	DC	DC	DC	DC	DC	
560 pF	561	J	K	M	CB	CB	CB	CB	CB	CB	CB	DC	DC	DC	DC	DC	DC	DC	
680 pF	681	J	K	M	CB	CB	CB	CB	CB	CB	CB	DC	DC	DC	DC	DC	DC	DC	
820 pF	821	J	K	M	CB	CB	CB	CB	CB	CB	CB	DC	DC	DC	DC	DC	DC	DC	
1,000 pF	102	J	K	M	CB	CB	CB	CB	CB	CB	CB	DC	DC	DC	DC	DC	DC	DC	
1,200 pF	122	J	K	M	CB	CB	CB	CB	CB	CB	CB	DC	DC	DC	DC	DC	DC	DC	
1,500 pF	152	J	K	M	CB	CB	CB	CB	CB	CB	CB	DC	DC	DC	DC	DC	DC	DC	
1,800 pF	182	J	K	M	CB	CB	CB	CB	CB	CB	CB	DC	DC	DC	DC	DC	DC	DC	
2,200 pF	222	J	K	M	CB	CB	CB	CB	CB	CB	CB	DC	DC	DC	DC	DC	DC	DC	
2,700 pF	272	J	K	M	CB	CB	CB	CB	CB	CB	CB	DC	DC	DC	DC	DC	DC	DC	
3,300 pF	332	J	K	M	CB	CB	CB	CB	CB	CB	CB	DC	DC	DC	DC	DC	DC	DC	
3,900 pF	392	J	K	M	CB	CB	CB	CB	CB	CB	CB	DC	DC	DC	DC	DC	DC	DC	
4,700 pF	472	J	K	M	CB	CB	CB	CB	CB	CB	CB	DC	DC	DC	DC	DC	DC	DC	
5,600 pF	562	J	K	M	CB	CB	CB	CB	CB	CB	CB	DC	DC	DC	DC	DC	DC	DC	
6,800 pF	682	J	K	M	CB	CB	CB	CB	CB	CB	CB	DC	DC	DC	DC	DC	DC	DC	
8,200 pF	822	J	K	M	CB	CB	CB	CB	CB	CB	CB	DC	DC	DC	DC	DC	DC	DC	
10,000 pF	103	J	K	M	CB	CB	CB	CB	CB	CB	CB	DC	DC	DC	DC	DC	DC	DC	
12,000 pF	123	J	K	M	CB	CB	CB	CB	CB	CB	CB	DC	DC	DC	DC	DC	DC	DC	
15,000 pF	153	J	K	M	CB	CB	CB	CB	CB	CB	CB	DC	DC	DC	DC	DC	DC	DC	
18,000 pF	183	J	K	M	CB	CB	CB	CB	CB	CB	CB	DC	DC	DC	DC	DC	DD		
22,000 pF	223	J	K	M	CB	CB	CB	CB	CB	CB	CB	DC	DC	DC	DC	DC	DD		
27,000 pF	273	J	K	M								DC	DC	DC	DC	DC			
33,000 pF	333	J	K	M								DC	DC	DC	DC	DC			
39,000 pF	393	J	K	M								DC	DC	DC	DC	DC			
47,000 pF	473	J	K	M								DC	DC	DC	DC	DC			
56,000 pF	563	J	K	M								DD	DD	DD	DD	DD			
68,000 pF	683	J	K	M								DD	DD	DD	DD	DD			
82,000 pF	823	J	K	M								DG	DG	DG	DG	DG			
0.10 µF	104	J	K	M								DG	DG	DG	DG	DG			
Cap	Cap Code	Voltage DC			6.3	10	16	25	50	100	200	6.3	10	16	25	50	100	200	250
		Voltage Code			9	8	4	3	5	1	2	9	8	4	3	5	1	2	A
		Series			C0603Y						C0805Y								

Surface Mount Multilayer Ceramic Chip Capacitors (SMD MLCCs)
KPS Series, X7R Dielectric, 10VDC-250VDC
(Commercial Grade)



Overview

KEMET Power Solutions (KPS) Commercial Series stacked capacitors utilize a proprietary lead-frame technology to vertically stack one or two multilayer ceramic chip capacitors into a single compact surface mount package. The attached lead-frame mechanically isolates the capacitor/s from the printed circuit board, therefore offering advanced mechanical and thermal stress performance. Isolation also addresses concerns for audible, microphonic noise that may occur when a bias voltage is applied. A two chip stack offers up to double the capacitance in the same or smaller design footprint when compared to traditional surface mount MLCC devices. Providing up to 10mm of board flex

capability, KPS Series capacitors are environmentally friendly and in compliance with RoHS legislation. Available in X7R dielectric, these devices are capable of Pb-Free reflow profiles and provide lower ESR, ESL and higher ripple current capability when compared to other dielectric solutions.

Combined with the stability of an X7R dielectric, KEMET's KPS Series devices exhibit a predictable change in capacitance with respect to time and voltage and boast a minimal change in capacitance with reference to ambient temperature. Capacitance change is limited to $\pm 15\%$ from -55°C to $+125^{\circ}\text{C}$.

Benefits

- -55°C to $+125^{\circ}\text{C}$ operating temperature range
- Reliable and robust termination system
- EIA 1210, 1812 and 2220 case sizes
- DC voltage ratings of 10V, 16V, 25V, 50V, 100V and 250V
- Capacitance offerings ranging from $0.1\mu\text{F}$ up to $47\mu\text{F}$
- Available capacitance tolerances of $\pm 10\%$ and $\pm 20\%$
- Higher capacitance in the same footprint
- Potential board space savings
- Advanced protection against thermal and mechanical stress
- Provides up to 10mm of board flex capability
- Reduces audible, microphonic noise
- Extremely low ESR and ESL
- Pb-Free and RoHS compliant
- Capable of Pb-Free reflow profiles
- Non-polar device, minimizing installation concerns
- Tantalum and electrolytic alternative

Applications

Typical applications include smoothing circuits, DC/DC converters, power supplies (input/output filters), noise reduction (piezoelectric/mechanical), circuits with a direct battery or power source connection, critical and safety relevant circuits without (integrated) current limitation and any application that is subject to high levels of board flexure or temperature cycling. Markets include industrial, military, automotive and telecom.

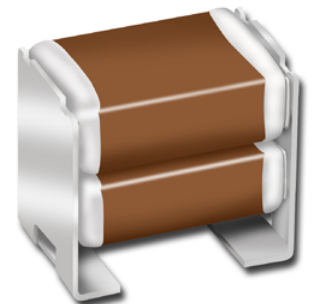

Ordering Information

C	1210	C	225	M	4	R	1	C	7186
Ceramic	Case Size (L" x W")	Specification/ Series	Capacitance Code (pF)	Capacitance Tolerance ¹	Voltage	Dielectric	Failure Rate/Design	Leadframe Finish ²	Packaging/Grade (C-Spec) ³
	1210 1812 2220	C = Standard	2 Sig. Digits + Number of Zeros	K = $\pm 10\%$ M = $\pm 20\%$	8 = 10V 4 = 16V 3 = 25V 5 = 50V 1 = 100V A = 250V	R = X7R	1 = KPS Single Chip Stack 2 = KPS Double Chip Stack	C = 100% Matte Sn	7186 = 7" Reel Unmarked 7289 = 13" Reel Unmarked

¹ Double chip stacks ("2" in the 13th character position of the ordering code) are only available in M ($\pm 20\%$) capacitance tolerance. Single chip stacks ("1" in the 13th character position of the ordering code) are available in K ($\pm 10\%$) or M ($\pm 20\%$) tolerances.

² Additional leadframe finish options may be available. Contact KEMET for details.

³ Additional reeling or packaging options may be available. Contact KEMET for details.

Dimensions – Millimeters (Inches)

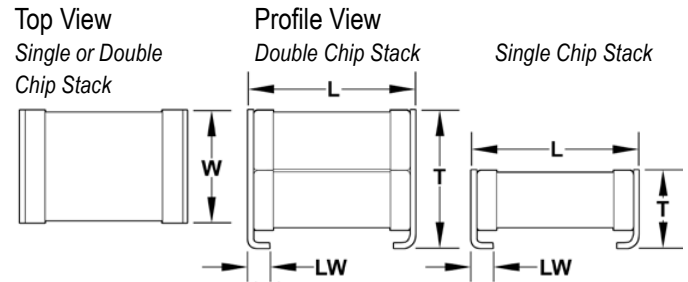

Chip Stack	EIA Size Code	Metric Size Code	L Length	W Width	T Thickness	LW Lead Width	Mounting Technique
Single	1210	3225	3.50 (.138) ± 0.30 (.012)	2.60 (.102) ± 0.30 (.012)	3.35 (.132) ± 0.10 (.004)	0.80 (.032) ± 0.15 (.006)	Solder Reflow Only
	1812	4532	5.00 (.197) ± 0.50 (.020)	3.50 (.138) ± 0.50 (.020)	2.65 (.104) ± 0.35 (.014)	1.10 (.043) ± 0.30 (.012)	
	2220	5650	6.00 (.236) ± 0.50 (.020)	5.00 (.197) ± 0.50 (.020)	3.50 (.138) ± 0.30 (.012)	1.60 (.063) ± 0.30 (.012)	
Double	1210	3225	3.50 (.138) ± 0.30 (.012)	2.60 (.102) ± 0.30 (.012)	6.15 (.242) ± 0.15 (.006)	0.80 (.031) ± 0.15 (.006)	
	1812	4532	5.00 (.197) ± 0.50 (.020)	3.50 (.138) ± 0.50 (.020)	5.00 (.197) ± 0.50 (.020)	1.10 (.043) ± 0.30 (.012)	
	2220	5650	6.00 (.236) ± 0.50 (.020)	5.00 (.197) ± 0.50 (.020)	5.00 (.197) ± 0.50 (.020)	1.60 (.063) ± 0.30 (.012)	

Qualification/Certification

Commercial grade products are subject to internal qualification. Details regarding test methods and conditions are referenced in Table 4, Performance and Reliability.

Environmental Compliance

Pb-Free and RoHS compliant

Electrical Parameters/Characteristics

Item	Parameters/Characteristics
Operating Temperature Range	-55°C to +125°C
Capacitance Change with Reference to +25°C and 0 VDC Applied (TCC)	±15%
Aging Rate (Max % Cap Loss/Decade Hour)	3.0%
Dielectric Withstanding Voltage	250% of rated voltage (5 ± 1 seconds and charge/discharge not exceeding 50mA)
Dissipation Factor (DF) Maximum Limits @ 25°C	5%(10V), 3.5%(16V & 25V) and 2.5%(50V to 250V)
Insulation Resistance (IR) Limit @ 25°C	See Insulation Resistance Limit Table (Rated voltage applied for 120 ± 5 secs @ 25°C)

Regarding Aging Rate: Capacitance measurements (including tolerance) are indexed to a referee time of 48 or 1000 Hours. Please refer to a part number specific datasheet for referee time details.

To obtain IR limit, divide $M\Omega\text{-}\mu\text{F}$ value by the capacitance and compare to $G\Omega$ limit. Select the lower of the two limits.

Capacitance and Dissipation Factor (DF) measured under the following conditions:

1kHz ± 50Hz and 1.0 ± 0.2 Vrms if capacitance $\leq 10\mu\text{F}$

120Hz ± 10Hz and 0.5 ± 0.1 Vrms if capacitance $> 10\mu\text{F}$

Note: When measuring capacitance it is important to ensure the set voltage level is held constant. The HP4284 & Agilent E4980 have a feature known as Automatic Level Control (ALC). The ALC feature should be switched to "ON".

Post Environmental Limits

High Temperature Life, Biased Humidity, Moisture Resistance					
Dielectric	Rated DC Voltage	Capacitance Value	DF (%)	Cap Shift	IR
X7R	>25	All	3.0	± 20%	10% of Initial Limit
	16 / 25		5.0		
	< 16		7.5		

Insulation Resistance Limit Table

EIA Case Size	1000 megohm microfarads or 100GΩ	500 megohm microfarads or 10GΩ
1210	< 0.39μF	≥ 0.39μF
1812	< 2.2μF	≥ 2.2μF
2220	< 10μF	≥ 10μF

Electrical Characteristics

Z and ESR C1210C475M5R1C

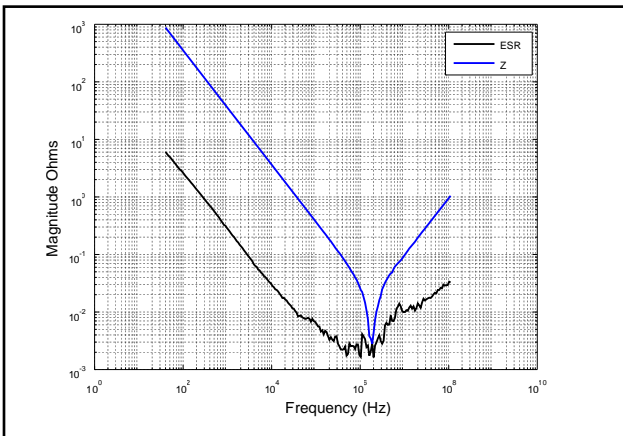

Z and ESR C2220C225MAR2C

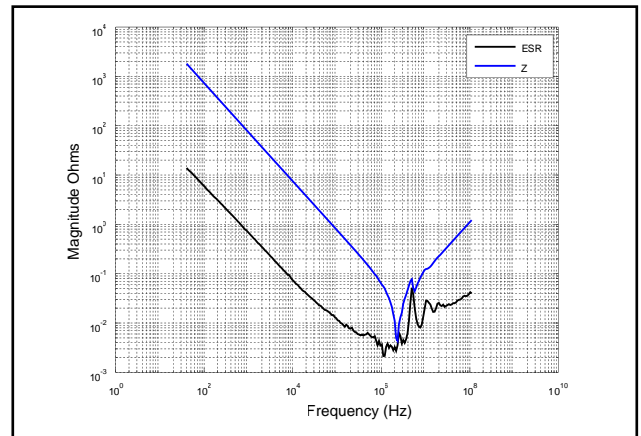

Z and ESR C2220C476M3R2C

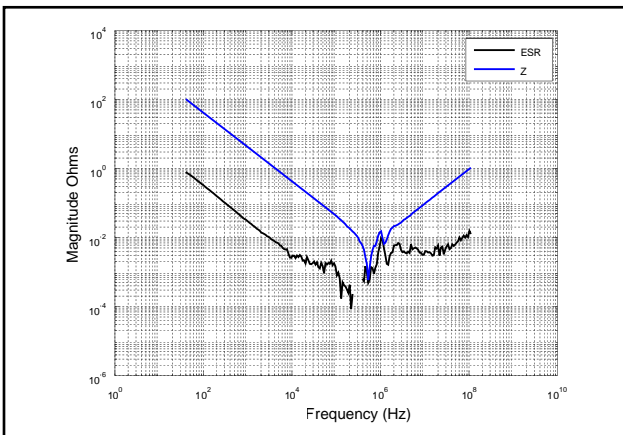

Electrical Characteristics

ESR - 1812, .10 μ F, 50V X7R

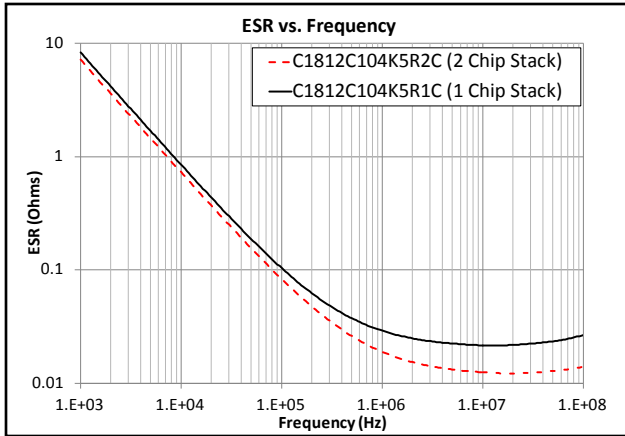

Impedance - 1812, .10 μ F, 50V X7R

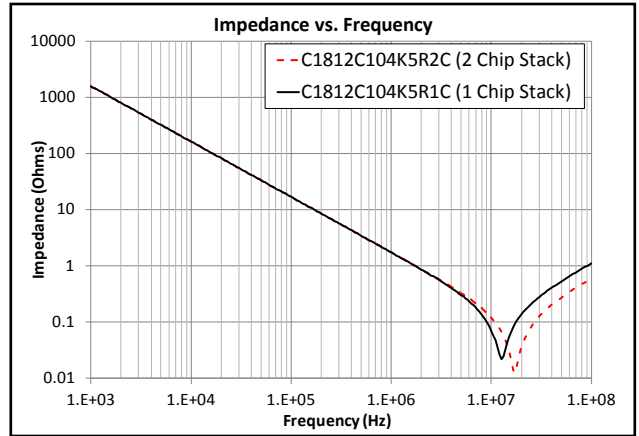

ESR - 1210, .22 μ F, 50V X7R

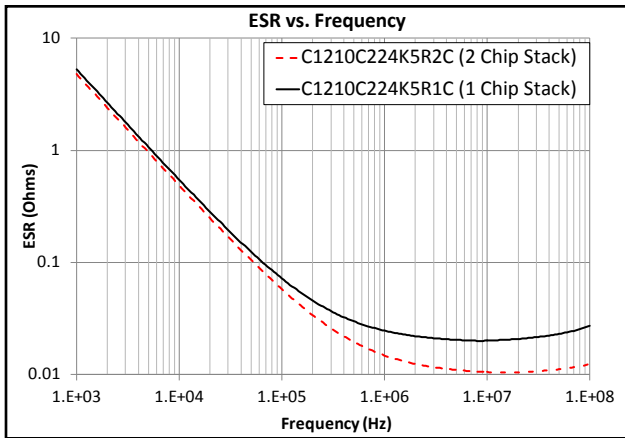

Impedance - 1210, .22 μ F, 50V X7R

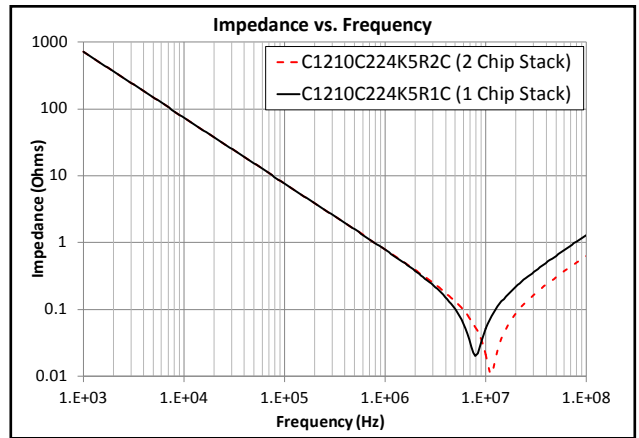

Electrical Characteristics cont

Microphonics - 1210, 4.7 μ F, 50V, X7R

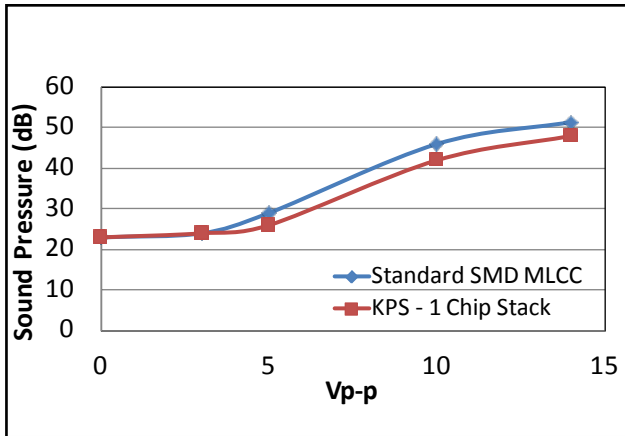

Microphonics - 2220, 22 μ F, 50V, X7R

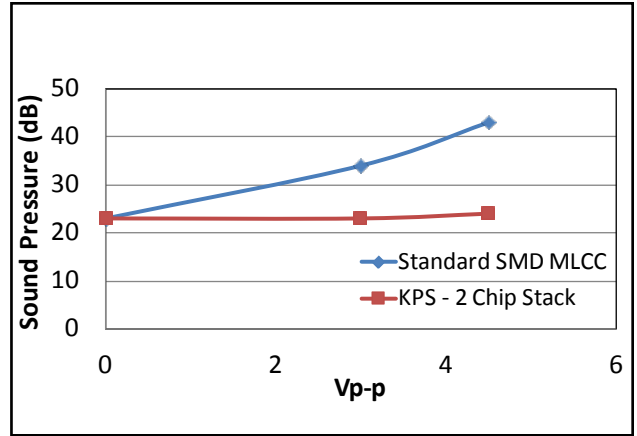

Microphonics - 2220, 47 μ F, 25V, X7R

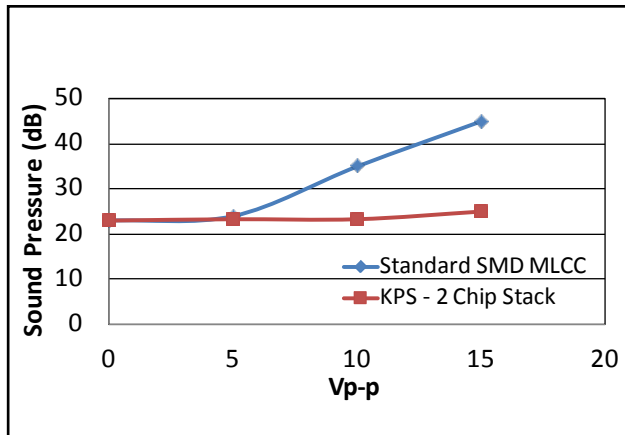

Microphonics - 1210, 22 μ F, 25V, X7R

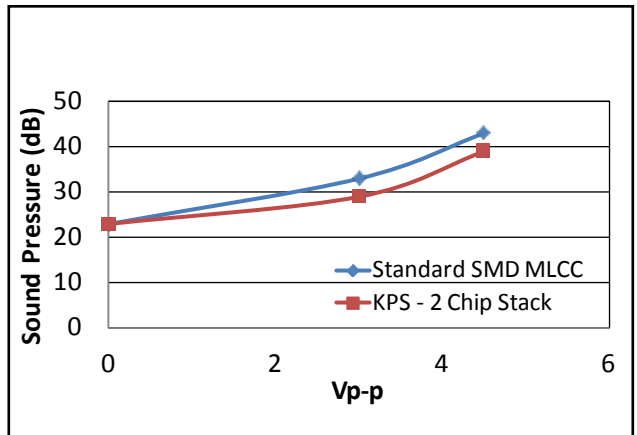

Competitive Comparison

Microphonics - 1210, 4.7 μ F, 50V, X7R

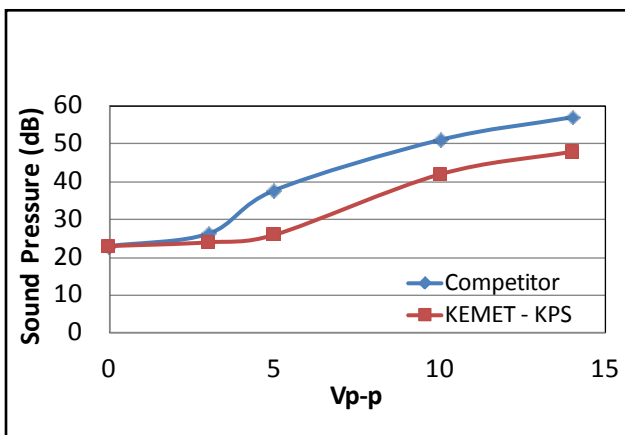

Ripple Current (Arms) 2220, 22 μ F, 50V

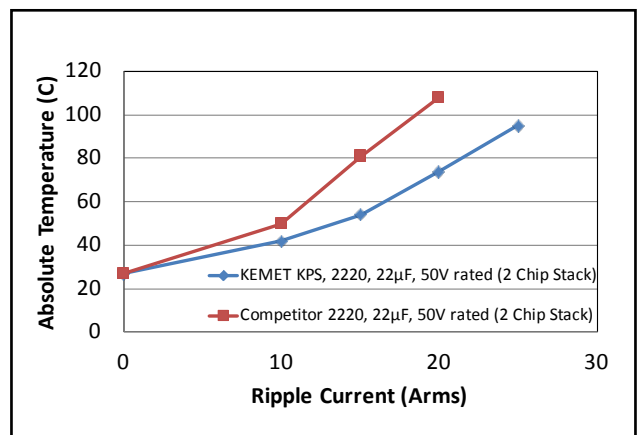

Note: Refer to Table 4 for test method.

Electrical Characteristics

Board Flex vs. Termination Type

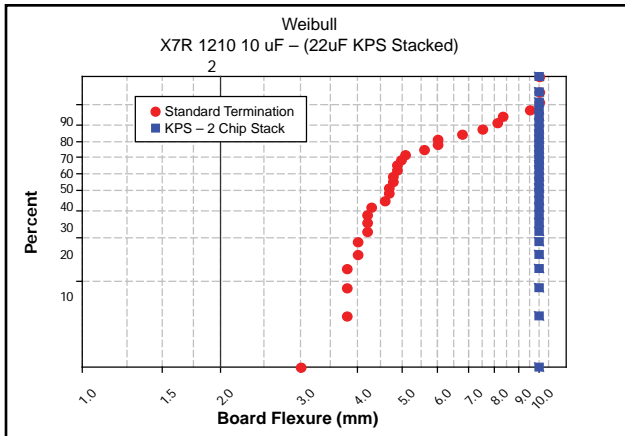

Board Flex vs. Termination Type

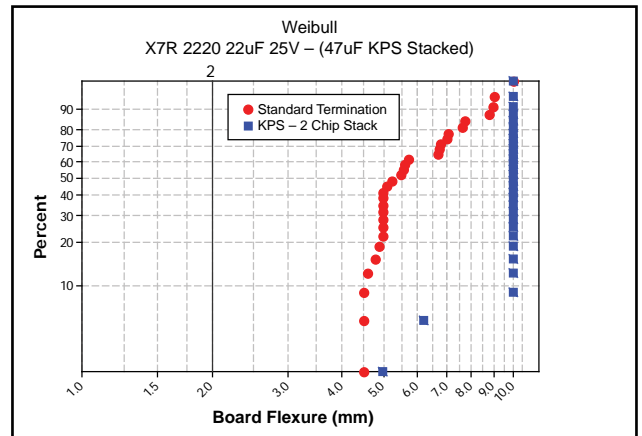

Board Flexure to 10mm

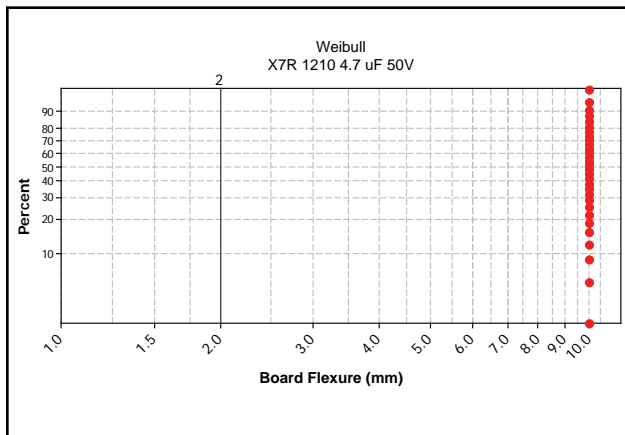

Board Flexure to 10mm

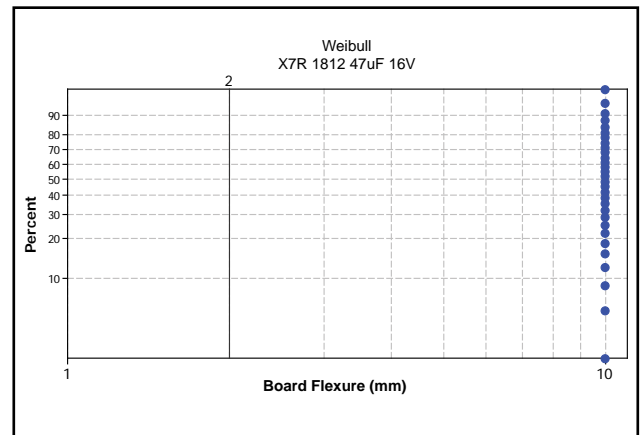

Table 1 – KPS Series, X7R Dielectric, (1210 - 2220 Case Sizes)

Cap	Cap Code	Series		C1210						C1812					C2220				
		Voltage Code		8	4	3	5	1	A	4	3	5	1	A	4	3	5	1	A
		Voltage DC		10	16	25	50	100	250	16	25	50	100	250	16	25	50	100	250
		Cap Tolerance		Product Availability and Chip Thickness Codes - See Table 2 for Chip Thickness Dimensions															
Single Chip Stack																			
0.10 µF	104	K	M	FV	FV	FV	FV	FV	FV	GP	GP	GP	GP	GP	JP	JP	JP	JP	JP
0.22 µF	224	K	M	FV	FV	FV	FV	FV	FV	GP	GP	GP	GP	GP	JP	JP	JP	JP	JP
0.47 µF	474	K	M	FV	FV	FV	FV	FV	FV	GP	GP	GP	GP	GP	JP	JP	JP	JP	JP
1.0 µF	105	K	M	FV	FV	FV	FV	FV	FV	GP	GP	GP	GP	GP	JP	JP	JP	JP	JP
2.2 µF	225	K	M	FV	FV	FV	FV	FV	FT ¹	GP	GP	GP	GP	GP	JP	JP	JP	JP	JP
3.3 µF	335	K	M	FV	FV	FV	FV	FV		GP	GP	GP			JP	JP	JP	JP	
4.7 µF	475	K	M	FV	FV	FV	FV			GP	GP	GP			JP	JP	JP	JP	
10 µF	106	K	M	FV	FV	FV				GP	GP				JP	JP	JP		
15 µF	156	K	M	FV											JP	JP			
22 µF	226	K	M	FV											JP	JP			
33 µF	336	K	M																
47 µF	476	K	M																
100 µF	107	K	M																
Double Chip Stack																			
0.10 µF	104		M	FW	FW	FW	FW	FW	FW	GR	GR	GR	GR	GR	JR	JR	JR	JR	JR
0.22 µF	224		M	FW	FW	FW	FW	FW	FW	GR	GR	GR	GR	GR	JR	JR	JR	JR	JR
0.47 µF	474		M	FW	FW	FW	FW	FW	FW	GR	GR	GR	GR	GR	JR	JR	JR	JR	JR
1.0 µF	105		M	FW	FW	FW	FW	FW	FW	GR	GR	GR	GR	GR	JR	JR	JR	JR	JR
2.2 µF	225		M	FW	FW	FW	FW	FW	FW	GR	GR	GR	GR	GR	JR	JR	JR	JR	JR
3.3 µF	335		M	FW	FW	FW	FW	FW	FW	GR	GR	GR	GR	GR	JR	JR	JR	JR	JR
4.7 µF	475		M	FW	FW	FW	FW	FW		GR	GR	GR			JR	JR	JR	JR	
10 µF	106		M	FW	FW	FW	FW			GR	GR	GR			JR	JR	JR		
22 µF	226		M	FW	FW	FW				GR	GR				JR	JR	JR		
33 µF	336		M	FW											JR	JR			
47 µF	476		M	FW											JR	JR			
100 µF	107		M																
220 µF	227		M																
Cap	Cap Code	Voltage DC		10	16	25	50	100	250	16	25	50	100	250	16	25	50	100	250
		Voltage Code		8	4	3	5	1	A	4	3	5	1	A	4	3	5	1	A
		Series		C1210						C1812					C2220				

Table 2 – Chip Thickness / Packaging Quantities

Thickness Code	Chip Size	Thickness ± Range (mm)	Qty per Reel 7" Plastic	Qty per Reel 13" Plastic
FV	1210	3.35 ± 0.10	600	2000
FW	1210	6.15 ± 0.15	300	1000
GP	1812	2.65 ± 0.35	500	2000
GR	1812	5.00 ± 0.50	400	1700
JP	2220	3.50 ± 0.30	300	1300
JR	2220	5.00 ± 0.50	200	800

Package Quantity Based on Finished Chip Thickness Specifications

Soldering Process

Recommended Soldering Technique:

- Solder reflow only

Recommended Soldering Profile:

- KEMET recommends following the guidelines outlined in IPC/JEDEC J-STD-020

Table 3 – KPS Land Pattern Design Recommendations

EIA Size Code	Metric Size Code	Median (Nominal) Land Protrusion (mm)		
		X	Y	2xC
1210	3225	1.75	1.14	3.00
1812	4532	2.87	1.35	4.39
2220	5650	4.78	2.08	5.38

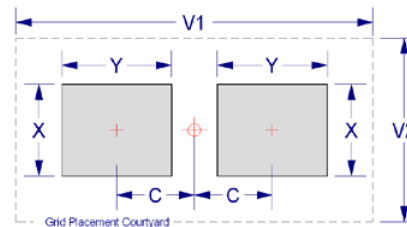
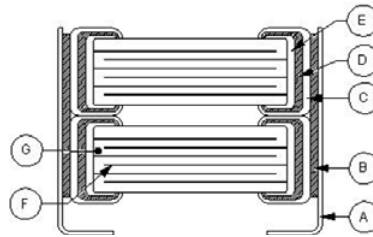

Table 4 – Performance & Reliability: Test Methods & Conditions

Stress	Reference	Test or Inspection Method
Terminal Strength	JIS-C-6429	Appendix 1, Note: Force of 1.8kg for 60 seconds.
Board Flex	JIS-C-6429	Appendix 2, Note: 2mm (min) for all except 3mm for COG.
Solderability	J-STD-002	Magnification 50 X. Conditions:
		a) Method B, 4 hrs @ 155°C, dry heat @ 235°C
		b) Method B @ 215°C category 3
	c) Method D, category 3 @ 260°C	
Temperature Cycling	JESD22 Method JA-104	1000 cycles (-55°C to +125°C), Measurement at 24 hrs. +/- 2 hrs after test conclusion.
Biased Humidity	MIL-STD-202 Method 103	Load Humidity: 1000 hours 85°C/85%RH and Rated Voltage. Add 100K ohm resistor. Measurement at 24 hrs. +/- 2 hrs after test conclusion.
		Low Volt Humidity: 1000 hours 85°C/85%RH and 1.5V. Add 100K ohm resistor. Measurement at 24 hrs. +/- 2 hrs after test conclusion.
Moisture Resistance	MIL-STD-202 Method 106	t = 24 hours/cycle. Steps 7a & 7b not required. Unpowered. Measurement at 24 hrs. +/- 2 hrs after test conclusion.
Thermal Shock	MIL-STD-202 Method 107	-55°C/+125°C. Note: Number of cycles required-300, maximum transfer time-20 seconds, dwell time-15 minutes. Air-Air.
High Temperature Life	MIL-STD-202 Method 108/ EIA-198	1000 hours at 125°C (85°C for X5R, Z5U and Y5V) with 2X rated voltage applied.
Storage Life	MIL-STD-202 Method 108	150°C, 0VDC, for 1000 hours.
Mechanical Shock	MIL-STD-202 Method 213	Figure 1 of Method 213, Condition F.
Resistance to Solvents	MIL-STD-202 Method 215	Add aqueous wash chemical - OKEM Clean or equivalent.

Construction

Ref	Name	Material
A	Leadframe	Phosphor Bronze - Alloy 510
B	Leadframe Attach	High Temp Solder
C	Termination	Cu
D		Ni
E		Sn
F	Electrode	Ni
G	Dielectric	BaTiO ₃



Storage and Handling

Ceramic chip capacitors should be stored in normal working environments. While the chips themselves are quite robust in other environments, solderability will be degraded by exposure to high temperatures, high humidity, corrosive atmospheres, and long term storage. In addition, packaging materials will be degraded by high temperature – reels may soften or warp, and tape peel force may increase. KEMET recommends that maximum storage temperature not exceed 40°C, and maximum storage humidity not exceed 70% relative humidity. In addition, temperature fluctuations should be minimized to avoid condensation on the parts, and atmospheres should be free of chlorine and sulfur bearing compounds. For optimized solderability, chip stock should be used promptly, preferably within 1.5 years of receipt.

Commercial "L" Series, SnPb Termination, C0G Dielectric 10VDC-200VDC (Commercial Grade)

Overview

KEMET's Commercial "L" Series with Tin/Lead Termination surface mount capacitors in C0G dielectric are designed to meet the needs of critical applications where tin/lead end metallization is required. KEMET's tin/lead electroplating process is designed to meet a 5% minimum lead content and address concerns for a more robust and reliable lead containing termination system. As the bulk of the electronics industry moves towards RoHS compliance, KEMET continues to provide tin/lead terminated products for military, aerospace and industrial applications and will ensure customers have a stable and long-term source of supply.

KEMET's C0G dielectric features a 125°C maximum operating temperature and is considered "stable." The Electronics Components, Assemblies & Materials Association (EIA) characterizes C0G dielectric as a Class I material. Components of this classification are temperature compensating and are suited for resonant circuit applications or those where Q and stability of capacitance characteristics are required. C0G exhibits no change in capacitance with respect to time and voltage and boasts a negligible change in capacitance with reference to ambient temperature. Capacitance change is limited to $\pm 30\text{ppm}/^\circ\text{C}$ from -55°C to $+125^\circ\text{C}$.

Benefits

- -55°C to $+125^\circ\text{C}$ operating temperature range
- Reliable and robust termination system
- EIA 0201, 0402, 0603, 0805, 1206, 1210, 1808, 1812, 1825, 2220 & 2225 case sizes
- DC voltage ratings of 10V, 16V, 25V, 50V, 100V and 200V
- Capacitance offerings ranging from 0.5pF up to 0.47 μF
- Available capacitance tolerances of $\pm 0.25\text{pF}$, $\pm 0.5\text{pF}$, $\pm 1\%$, $\pm 2\%$, $\pm 5\%$, $\pm 10\%$ and $\pm 20\%$
- No piezoelectric noise
- Extremely low ESR and ESL
- High thermal stability
- High ripple current capability
- Preferred capacitance solution at line frequencies and into the MHz range

- No capacitance change with respect to applied rated DC voltage
- Negligible capacitance change with respect to temperature from -55°C to $+125^\circ\text{C}$
- No capacitance decay with time
- Non-polar device, minimizing installation concerns
- SnPb plated termination finish (5% min)
- Flexible termination option available upon request
- Available for other surface mount products, additional dielectrics and higher voltage ratings upon request

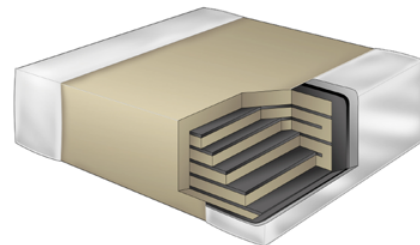

Ordering Information

C	1206	C	104	J	3	G	A	L	TU
Ceramic	Case Size (L" x W")	Specification/ Series	Capacitance Code (pF)	Capacitance Tolerance ¹	Voltage	Dielectric	Failure Rate/ Design	Termination Finish ²	Packaging/Grade (C-Spec) ³
	0402 0603 0805 1206 1210 1808 1812 1825 2220 2225	C = Standard	2 Sig. Digits + Number of Zeros Use 9 for 1.0 - 9.9pF Use 8 for 0.5 - .99pF ex. 2.2pF = 229 ex. 0.5pF = 508	C = $\pm 0.25\text{pF}$ D = $\pm 0.5\text{pF}$ F = $\pm 1\%$ G = $\pm 2\%$ J = $\pm 5\%$ K = $\pm 10\%$ M = $\pm 20\%$	8 = 10V 4 = 16V 3 = 25V 5 = 50V 1 = 100V 2 = 200V	G = C0G	A = N/A	L = SnPb (5% min)	Blank = Bulk TU = 7" Reel Unmarked

¹ Additional capacitance tolerance offerings may be available. Contact KEMET for details.

² Additional termination finish options may be available. Contact KEMET for details.

³ Additional reeling or packaging options may be available. Contact KEMET for details.

Dimensions – Millimeters (Inches)

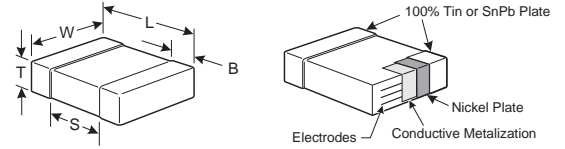

EIA Size Code	Metric Size Code	L Length	W Width	T Thickness	B Bandwidth	S Separation Min.	Mounting Technique
0402	1005	1.00 (.040) ± 0.05 (.002)	0.50 (.020) ± 0.05 (.002)	See Table 2 for Thickness	0.30 (.012) ± 0.10 (.004)	0.30 (.012)	Solder Reflow Only
0603	1608	1.60 (.063) ± 0.15 (.006)	0.80 (.032) ± 0.15 (.006)		0.35 (.014) ± 0.15 (.006)	0.70 (.028)	Solder Wave or Solder Reflow
0805	2012	2.00 (.079) ± 0.20 (.008)	1.25 (.049) ± 0.20 (.008)		0.50 (0.02) ± 0.25 (.010)	0.75 (.030)	
1206	3216	3.20 (.126) ± 0.20 (.008)	1.60 (.063) ± 0.20 (.008)		0.50 (0.02) ± 0.25 (.010)	N/A	Solder Reflow Only
1210	3225	3.20 (.126) ± 0.20 (.008)	2.50 (.098) ± 0.20 (.008)		0.50 (0.02) ± 0.25 (.010)		
1808	4520	4.70 (.185) ± 0.50 (.020)	2.00 (.079) ± 0.20 (.008)		0.60 (.024) ± 0.35 (.014)		
1812	4532	4.50 (.177) ± 0.30 (.012)	3.20 (.126) ± 0.30 (.012)		0.60 (.024) ± 0.35 (.014)		
1825	4564	4.50 (.177) ± 0.30 (.012)	6.40 (.252) ± 0.40 (.016)		0.60 (.024) ± 0.35 (.014)		
2220	5650	5.70 (.224) ± 0.40 (.016)	5.00 (.197) ± 0.40 (.016)		0.60 (.024) ± 0.35 (.014)		
2225	5664	5.60 (.220) ± 0.40 (.016)	6.40 (.248) ± 0.40 (.016)		0.60 (.024) ± 0.35 (.014)		

Applications

Typical applications include military, aerospace and other high reliability applications.

Qualification/Certification

Commercial grade products are subject to internal qualification. Details regarding test methods and conditions are referenced in Table 4, Performance and Reliability.

Environmental Compliance

These devices do not meet RoHS criteria due to the concentration of Pb containment in the termination finish

Electrical Parameters/Characteristics

Item	Parameters/Characteristics
Operating Temperature Range	-55°C to +125°C
Capacitance Change with Reference to +25°C and 0 Vdc Applied (TCC)	±30PPM/°C
Aging Rate (Max % Cap Loss/Decade Hour)	0%
Dielectric Withstanding Voltage	250% of rated voltage (5 ± 1 seconds and charge/discharge not exceeding 50mA)
Dissipation Factor (DF) Maximum Limit @ 25°C	0.1%
Insulation Resistance (IR) Limit @ 25°C	1000 megohm microfarads or 100GΩ (Rated voltage applied for 120 ± 5 secs @ 25°C)

To obtain IR limit, divide MΩ-μF value by the capacitance and compare to GΩ limit. Select the lower of the two limits.

Capacitance and Dissipation Factor (DF) measured under the following conditions:

1MHz ± 100kHz and 1.0Vrms ± 0.2V if capacitance ≤1000pF

1kHz ± 50Hz and 1.0Vrms ± 0.2V if capacitance >1000pF

Note: When measuring capacitance it is important to ensure the set voltage level is held constant. The HP4284 & Agilent E4980 have a feature known as Automatic Level Control (ALC). The ALC feature should be switched to "ON".

Post Environmental Limits

High Temperature Life, Biased Humidity, Moisture Resistance					
Dielectric	Rated DC Voltage	Capacitance Value	DF (%)	Cap Shift	IR
C0G	All	All	0.5	0.3% or ± 0.25 pF	10% of Initial Limit

Table 1A – SnPb Termination, C0G Dielectric, (0402 - 1206 Case Sizes)

Cap	Cap Code	Series		C0402						C0603						C0805						C1206																																
		Voltage Code		8	4	3	5	1	2	8	4	3	5	1	2	8	4	3	5	1	2	8	4	3	5	1	2																											
		Voltage DC		10	16	25	50	100	200	10	16	25	50	100	200	10	16	25	50	100	200	10	16	25	50	100	200																											
		Cap Tolerance	Product Availability and Chip Thickness Codes - See Table 2 for Chip Thickness Dimensions																																																			
0.50-0.75 pF	508-759	C	D							BB	BB	BB	BB			CB	CB	CB	CB	CB	CB	DC	DC	DC	DC	DC	DC	DC	DC	DC	DC	DC	DC	DC	DC	DC	DC	DC	DC	DC														
1.0-2.4 pF	109-249	C	D							BB	BB	BB	BB			CB	CB	CB	CB	CB	CB	DC	DC	DC	DC	DC	DC	DC	DC	DC	DC	DC	DC	DC	DC	DC	DC	DC	DC	DC	DC	DC	DC											
2.7-5.1 pF	279	C	D		J	K	M			BB	BB	BB	BB			CB	CB	CB	CB	CB	CB	DC	DC	DC	DC	DC	DC	DC	DC	DC	DC	DC	DC	DC	DC	DC	DC	DC	DC	DC	DC	DC	DC	DC										
5.6 pF	569	C	D		G	J	K	M		BB	BB	BB	BB			CB	CB	CB	CB	CB	CB	DC	DC	DC	DC	DC	DC	DC	DC	DC	DC	DC	DC	DC	DC	DC	DC	DC	DC	DC	DC	DC	DC	DC	DC									
6.2 pF	629	C	D		G	J	K	M		BB	BB	BB	BB			CB	CB	CB	CB	CB	CB	DC	DC	DC	DC	DC	DC	DC	DC	DC	DC	DC	DC	DC	DC	DC	DC	DC	DC	DC	DC	DC	DC	DC	DC	DC								
6.8 pF	689	C	D		G	J	K	M		BB	BB	BB	BB			CB	CB	CB	CB	CB	CB	DC	DC	DC	DC	DC	DC	DC	DC	DC	DC	DC	DC	DC	DC	DC	DC	DC	DC	DC	DC	DC	DC	DC	DC	DC	DC							
7.5 pF	759	C	D		G	J	K	M		BB	BB	BB	BB			CB	CB	CB	CB	CB	CB	DC	DC	DC	DC	DC	DC	DC	DC	DC	DC	DC	DC	DC	DC	DC	DC	DC	DC	DC	DC	DC	DC	DC	DC	DC	DC							
8.2 pF	829	C	D		G	J	K	M		BB	BB	BB	BB			CB	CB	CB	CB	CB	CB	DC	DC	DC	DC	DC	DC	DC	DC	DC	DC	DC	DC	DC	DC	DC	DC	DC	DC	DC	DC	DC	DC	DC	DC	DC	DC	DC						
9.1 pF	919	C	D		G	J	K	M		BB	BB	BB	BB			CB	CB	CB	CB	CB	CB	DC	DC	DC	DC	DC	DC	DC	DC	DC	DC	DC	DC	DC	DC	DC	DC	DC	DC	DC	DC	DC	DC	DC	DC	DC	DC	DC	DC					
10 pF	100	C	D		G	J	K	M		BB	BB	BB	BB			CB	CB	CB	CB	CB	CB	DC	DC	DC	DC	DC	DC	DC	DC	DC	DC	DC	DC	DC	DC	DC	DC	DC	DC	DC	DC	DC	DC	DC	DC	DC	DC	DC	DC					
11 pF	110	C	D		G	J	K	M		BB	BB	BB	BB			CB	CB	CB	CB	CB	CB	DC	DC	DC	DC	DC	DC	DC	DC	DC	DC	DC	DC	DC	DC	DC	DC	DC	DC	DC	DC	DC	DC	DC	DC	DC	DC	DC	DC	DC				
12 pF	120	D	D		G	J	K	M		BB	BB	BB	BB			CB	CB	CB	CB	CB	CB	DC	DC	DC	DC	DC	DC	DC	DC	DC	DC	DC	DC	DC	DC	DC	DC	DC	DC	DC	DC	DC	DC	DC	DC	DC	DC	DC	DC	DC				
13 pF	130	D	D		G	J	K	M		BB	BB	BB	BB			CB	CB	CB	CB	CB	CB	DC	DC	DC	DC	DC	DC	DC	DC	DC	DC	DC	DC	DC	DC	DC	DC	DC	DC	DC	DC	DC	DC	DC	DC	DC	DC	DC	DC	DC	DC			
15 pF	150	D	D		G	J	K	M		BB	BB	BB	BB			CB	CB	CB	CB	CB	CB	DC	DC	DC	DC	DC	DC	DC	DC	DC	DC	DC	DC	DC	DC	DC	DC	DC	DC	DC	DC	DC	DC	DC	DC	DC	DC	DC	DC	DC	DC			
16 pF	160	D	D		G	J	K	M		BB	BB	BB	BB			CB	CB	CB	CB	CB	CB	DC	DC	DC	DC	DC	DC	DC	DC	DC	DC	DC	DC	DC	DC	DC	DC	DC	DC	DC	DC	DC	DC	DC	DC	DC	DC	DC	DC	DC	DC	DC		
18 pF	180	D	F	G	J	K	M			BB	BB	BB	BB			CB	CB	CB	CB	CB	CB	DC	DC	DC	DC	DC	DC	DC	DC	DC	DC	DC	DC	DC	DC	DC	DC	DC	DC	DC	DC	DC	DC	DC	DC	DC	DC	DC	DC	DC	DC	DC		
20 pF	200	D	F	G	J	K	M			BB	BB	BB	BB			CB	CB	CB	CB	CB	CB	DC	DC	DC	DC	DC	DC	DC	DC	DC	DC	DC	DC	DC	DC	DC	DC	DC	DC	DC	DC	DC	DC	DC	DC	DC	DC	DC	DC	DC	DC	DC		
22 pF	220	D	F	G	J	K	M			BB	BB	BB	BB			CB	CB	CB	CB	CB	CB	DC	DC	DC	DC	DC	DC	DC	DC	DC	DC	DC	DC	DC	DC	DC	DC	DC	DC	DC	DC	DC	DC	DC	DC	DC	DC	DC	DC	DC	DC	DC	DC	
24 pF	240	D	F	G	J	K	M			BB	BB	BB	BB			CB	CB	CB	CB	CB	CB	DC	DC	DC	DC	DC	DC	DC	DC	DC	DC	DC	DC	DC	DC	DC	DC	DC	DC	DC	DC	DC	DC	DC	DC	DC	DC	DC	DC	DC	DC	DC	DC	
27 pF	270	F	F	G	J	K	M			BB	BB	BB	BB			CB	CB	CB	CB	CB	CB	DC	DC	DC	DC	DC	DC	DC	DC	DC	DC	DC	DC	DC	DC	DC	DC	DC	DC	DC	DC	DC	DC	DC	DC	DC	DC	DC	DC	DC	DC	DC	DC	
30 pF	300	F	F	G	J	K	M			BB	BB	BB	BB			CB	CB	CB	CB	CB	CB	DC	DC	DC	DC	DC	DC	DC	DC	DC	DC	DC	DC	DC	DC	DC	DC	DC	DC	DC	DC	DC	DC	DC	DC	DC	DC	DC	DC	DC	DC	DC	DC	
33 pF	330	F	F	G	J	K	M			BB	BB	BB	BB			CB	CB	CB	CB	CB	CB	DC	DC	DC	DC	DC	DC	DC	DC	DC	DC	DC	DC	DC	DC	DC	DC	DC	DC	DC	DC	DC	DC	DC	DC	DC	DC	DC	DC	DC	DC	DC	DC	
36 pF	360	F	F	G	J	K	M			BB	BB	BB	BB			CB	CB	CB	CB	CB	CB	DC	DC	DC	DC	DC	DC	DC	DC	DC	DC	DC	DC	DC	DC	DC	DC	DC	DC	DC	DC	DC	DC	DC	DC	DC	DC	DC	DC	DC	DC	DC	DC	DC
39 pF	390	F	F	G	J	K	M			BB	BB	BB	BB			CB	CB	CB	CB	CB	CB	DC	DC	DC	DC	DC	DC	DC	DC	DC	DC	DC	DC	DC	DC	DC	DC	DC	DC	DC	DC	DC	DC	DC	DC	DC	DC	DC	DC	DC	DC	DC	DC	DC
43 pF	430	F	F	G	J	K	M			BB	BB	BB	BB			CB	CB	CB	CB	CB	CB	DC	DC	DC	DC	DC	DC	DC	DC	DC	DC	DC	DC	DC	DC	DC	DC	DC	DC	DC	DC	DC	DC	DC	DC	DC	DC	DC	DC	DC	DC	DC	DC	DC
47 pF	470	F	F	G	J	K	M			BB	BB	BB	BB			CB	CB	CB	CB	CB	CB	DC	DC	DC	DC	DC	DC	DC	DC	DC	DC	DC	DC	DC	DC	DC	DC	DC	DC	DC	DC	DC	DC	DC	DC	DC	DC	DC	DC	DC	DC	DC	DC	DC
51 pF	510	F	F	G	J	K	M			BB	BB	BB	BB			CB	CB	CB	CB	CB	CB	DC	DC	DC	DC	DC	DC	DC	DC	DC	DC	DC	DC	DC	DC	DC	DC	DC	DC	DC	DC	DC	DC	DC	DC	DC	DC	DC	DC	DC	DC	DC	DC	DC
56 pF	560	F	F	G	J	K	M			BB	BB	BB	BB			CB	CB	CB	CB	CB	CB	DC	DC	DC	DC	DC	DC	DC	DC	DC	DC	DC	DC	DC	DC	DC	DC	DC	DC	DC	DC	DC	DC	DC	DC	DC	DC	DC	DC	DC	DC	DC	DC	DC
62 pF	620	F	F	G	J	K	M			BB	BB	BB	BB			CB	CB	CB	CB	CB	CB	DC	DC	DC	DC	DC	DC	DC	DC	DC	DC	DC	DC	DC	DC	DC	DC	DC	DC	DC	DC	DC	DC	DC	DC	DC	DC	DC	DC	DC	DC	DC	DC	DC
68 pF	680	F	F	G	J	K	M			BB	BB	BB	BB			CB	CB	CB	CB	CB	CB	DC	DC	DC	DC	DC	DC	DC	DC	DC	DC	DC	DC	DC	DC	DC	DC	DC	DC	DC	DC	DC	DC	DC	DC	DC	DC	DC	DC	DC	DC	DC	DC	DC
75 pF	750	F	F	G	J	K	M			BB	BB	BB	BB			CB	CB	CB	CB	CB	CB	DC	DC	DC	DC	DC	DC	DC	DC	DC	DC	DC	DC	DC	DC	DC	DC	DC	DC	DC	DC	DC	DC	DC	DC	DC	DC	DC	DC	DC	DC	DC	DC	DC
82 pF	820	F	F	G	J	K	M			BB	BB	BB	BB			CB	CB	CB	CB	CB	CB	DC	DC	DC	DC	DC	DC	DC	DC	DC	DC	DC	DC	DC	DC	DC	DC	DC	DC	DC	DC	DC	DC	DC	DC	DC	DC	DC	DC	DC	DC	DC	DC	DC
91 pF	910	F	F	G	J	K	M																																															

Table 1A – SnPb Termination, COG Dielectric, (0402 - 1206 Case Sizes) con't

Cap	Cap Code	Series	C0402						C0603						C0805						C1206					
		Voltage Code	8	4	3	5	1	2	8	4	3	5	1	2	8	4	3	5	1	2	8	4	3	5	1	2
		Voltage DC	10	16	25	50	100	200	10	16	25	50	100	200	10	16	25	50	100	200	10	16	25	50	100	200
		Cap Tolerance	Product Availability and Chip Thickness Codes - See Table 2 for Chip Thickness Dimensions																							
3,000 pF	302	F G J K M							CB	CB	CB	CB	CB		DD	DD	DD	DD	DC	UD	EC	EC	EC	EC	EC	UD
3,300 pF	332	F G J K M							CB	CB	CB	CB	CB		DD	DD	DD	DD	DC	UD	EC	EC	EC	EC	EE	UD
3,600 pF	362	F G J K M							CB	CB	CB	CB	CB		DD	DD	DD	DD	DC	UD	EC	EC	EC	EC	EE	UD
3,900 pF	392	F G J K M							CB	CB	CB	CB	CB		DE	DE	DE	DE	DC	UD	EC	EC	EC	EC	EE	UD
4,300 pF	432	F G J K M							CB	CB	CB	CB	CB		DE	DE	DE	DE	DC	UD	EC	EC	EC	EC	EE	UD
4,700 pF	472	F G J K M							CB	CB	CB	CB	CB		DE	DE	DE	DE	DC	UD	EC	EC	EC	EC	EE	UD
5,100 pF	512	F G J K M							CB	CB	CB	CB	CB		DE	DE	DE	DE	DC	UD	ED	ED	ED	ED	ED	UD
5,600 pF	562	F G J K M							CB	CB	CB	CB	CB		DC	DC	DC	DC	DC	UD	ED	ED	ED	ED	ED	UD
6,200 pF	622	F G J K M							CB	CB	CB	CB	CB		DC	DC	DC	DC	DC	UD	EB	EB	EB	EB	EB	UD
6,800 pF	682	F G J K M							CB	CB	CB	CB	CB		DC	DC	DC	DC	DC	UD	EB	EB	EB	EB	EB	UD
7,500 pF	752	F G J K M							CB	CB	CB	CB	CB		DC	DC	DC	DC	DC	UD	EB	EB	EB	EB	EB	UD
8,200 pF	822	F G J K M							CB	CB	CB	CB	CB		DC	DC	DC	DC	DC	UD	EC	EC	EC	EC	EB	UD
9,100 pF	912	F G J K M							CB	CB	CB	CB	CB		DC	DC	DC	DC	DC	UD	EC	EC	EC	EC	EB	UD
10,000 pF	103	F G J K M							CB	CB	CB	CB	CB		DC	DC	DC	DC	DD		ED	ED	ED	ED	EB	UD
12,000 pF	123	F G J K M							CB	CB	CB	CB	CB		DC	DC	DC	DC	DE		EB	EB	EB	EB	EB	UD
15,000 pF	153	F G J K M							CB	CB	CB	CB	CB		DC	DC	DC	DD	DG		EB	EB	EB	EB	EB	UD
18,000 pF	183	F G J K M							CB	CB	CB	CB	CB		DC	DC	DC	DD			EB	EB	EB	EB	EB	UD
22,000 pF	223	F G J K M													DD	DD	DD	DF			EB	EB	EB	EB	EC	UD
27,000 pF	273	F G J K M													DF	DF	DF				EB	EB	EB	EB	EE	
33,000 pF	333	F G J K M													DG	DG	DG				EB	EB	EB	EB	EE	
39,000 pF	393	F G J K M													DG	DG	DG				EC	EC	EC	EE	EH	
47,000 pF	473	F G J K M													DG	DG	DG				EC	EC	EC	EE	EH	
56,000 pF	563	F G J K M																			ED	ED	ED	EF		
68,000 pF	683	F G J K M																			EF	EF	EF	EH		
82,000 pF	823	F G J K M																			EH	EH	EH	EH		
0.10 μF	104	F G J K M																			EH	EH	EH			
Cap	Cap Code	Voltage DC	10	16	25	50	100	200	10	16	25	50	100	200	10	16	25	50	100	200	10	16	25	50	100	200
Cap	Cap Code	Voltage Code	8	4	3	5	2	1	8	4	3	5	1	2	8	4	3	5	1	2	8	4	3	5	1	2
Cap	Cap Code	Series	C0402						C0603						C0805						C1206					

Table 1B – (1210 - 2225 Case Sizes)

Cap	Cap Code	Series	C1210						C1808			C1812			C1825			C2220			C2225					
		Voltage Code	8	4	3	5	1	2	5	1	2	5	1	2	5	1	2	3	1	2	5	1	2			
		Voltage DC	10	16	25	50	100	200	50	100	200	50	100	200	50	100	200	50	100	200	50	100	200			
		Cap Tolerance	Product Availability and Chip Thickness Codes - See Table 2 for Chip Thickness Dimensions																							
0.5-0.75 pF	508-758	D																								
1.0-2.4 pF	109-249	D																								
2.7-9.1 pF	279-919	D							FB	FB	FB	FB	FB	FB												
10-13 pF	100-130	D							FB	FB	FB	FB	FB	FB												
15-24 pF	150-240	D							FB	FB	FB	FB	FB	FB												
27-51 pF	270-510	D	F	G	J	K	M		FB	FB	FB	FB	FB	FB												
56-82 pF	560-820	D	F	G	J	K	M		FB	FB	FB	FB	FB	FB												
91-200 pF	910-201	D	F	G	J	K	M		FB	FB	FB	FB	FB	FB												
220-300 pF	221-301	D	F	G	J	K	M		FB	FB	FB	FB	FB	FB												
330-430 pF	331-431	D	F	G	J	K	M		FB	FB	FB	FB	FB	FB	LE	LE	LE									
470-910 pF	471-911	D	F	G	J	K	M		FB	FB	FB	FB	FB	FB	LE	LE	LE	GB	GB	GB						
1,000 pF	102	D	F	G	J	K	M		FB	FB	FB	FB	FB	FB	LE	LE	LE	GB	GB	GB						
Cap	Cap Code	Voltage DC	10	16	25	50	100	200	50	100	200	50	100	200	50	100	200	50	100	200	50	100	200			
Cap	Cap Code	Voltage Code	8	4	3	5	1	2	5	1	2	5	1	2	5	1	2	3	1	2	5	1	2			
Cap	Cap Code	Series	C1210						C1808			C1812			C1825			C2220			C2225					

UD = Under Development

KEMET reserves the right to substitute product with an improved temperature characteristic, tighter capacitance tolerance and/or higher voltage capability within the same form factor (configuration and dimensions).

These products are protected under US Patents 7,172,985 & 7,670,981, other patents pending, and any foreign counterparts.

Table 1B – SnPb Termination, COG Dielectric, (1210 - 2225 Case Sizes) con't

Cap	Cap Code	Series						C1210						C1808			C1812			C1825			C2220			C2225														
		Voltage Code						8	4	3	5	1	2	5	1	2	5	1	2	5	1	2	3	1	2	5	1	2												
		Voltage DC						10	16	25	50	100	200	50	100	200	50	100	200	50	100	200	50	100	200	50	100	200												
		Cap Tolerance						Product Availability and Chip Thickness Codes - See Table 2 for Chip Thickness Dimensions																																
1,100 pF	112	D	F	G	J	K	M	FB	FB	FB	FB	FB	FB	LE	LE	LE	GB	GB	GB																					
1,200 pF	122	D	F	G	J	K	M	FB	FB	FB	FB	FB	FB	LE	LE	LE	GB	GB	GB																					
1,300 pF	132		F	G	J	K	M	FB	FB	FB	FB	FB	FC	LE	LE	LE	GB	GB	GB																					
1,500 pF	152		F	G	J	K	M	FB	FB	FB	FB	FB	FE	LE	LE	LE	GB	GB	GB																					
1,600 pF	162		F	G	J	K	M	FB	FB	FB	FB	FB	FE	LE	LE	LE	GB	GB	GB																					
1,800 pF	182		F	G	J	K	M	FB	FB	FB	FB	FB	FE	LE	LE	LE	GB	GB	GB																					
2,000 pF	202		F	G	J	K	M	FB	FB	FB	FB	FC	FE	LE	LE	LE	GB	GB	GB																					
2,200 pF	222		F	G	J	K	M	FB	FB	FB	FB	FC	FG	LE	LE	LE	GB	GB	GB																					
2,400 pF	242		F	G	J	K	M	FB	FB	FB	FB	FC	FC	LE	LE	LE	GB	GB	GB																					
2,700 pF	272		F	G	J	K	M	FB	FB	FB	FB	FC	FC	LE	LE	LE	GB	GB	GB																					
3,000 pF	302		F	G	J	K	M	FB	FB	FB	FB	FC	FF	LE	LE																									
3,300 pF	332		F	G	J	K	M	FB	FB	FB	FB	FF	FF	LE	LE		GB	GB	GB																					
3,600 pF	362		F	G	J	K	M	FB	FB	FB	FB	FF	FF	LE	LE																									
3,900 pF	392		F	G	J	K	M	FB	FB	FB	FB	FF	FF	LE	LE		GB	GB	GB	HB	HB	HB																		
4,300 pF	432		F	G	J	K	M	FB	FB	FB	FB	FF	FF	LE	LE																									
4,700 pF	472		F	G	J	K	M	FF	FF	FF	FF	FG	FG	LE	LE		GB	GB	GD	HB	HB	HB												KB	KB	KB				
5,100 pF	512		F	G	J	K	M	FB	FB	FB	FB	FG	FG																							KB	KB	KB		
5,600 pF	562		F	G	J	K	M	FB	FB	FB	FB	FG	FG				GB	GB	GH	HB	HB	HB													KB	KB	KB			
6,200 pF	622		F	G	J	K	M	FB	FB	FB	FB	FG	UD																											
6,800 pF	682		F	G	J	K	M	FB	FB	FB	FB	FG	UD				GB	GB	GJ	HB	HB	HB											UD		KB	KB	KB			
7,500 pF	752		F	G	J	K	M	FC	FC	FC	FC	FC	UD																											
8,200 pF	822		F	G	J	K	M	FC	FC	FC	FC	FC	UD				GB	GH	UD	HB	HB	HB												UD		KB	KB	KB		
9,100 pF	912		F	G	J	K	M	FE	FE	FE	FE	FE	UD																											
10,000 pF	103		F	G	J	K	M	FF	FF	FF	FF	FF	UD				GB	GH	UD	HB	HB	HE													UD		KB	KB	KB	
12,000 pF	123		F	G	J	K	M	FG	FG	FG	FG	FB	UD				GB	GG	UD	HB	HB	HE													UD		KB	KB	KB	
15,000 pF	153		F	G	J	K	M	FG	FG	FG	FG	FB	UD				GB	GB	UD	HB	HB															UD		KB	KB	KE
18,000 pF	183		F	G	J	K	M	FB	FB	FB	FB	FB	UD				GB	GB	UD	HB	HE															UD		KB	KB	
22,000 pF	223		F	G	J	K	M	FB	FB	FB	FB	FB	UD				GB	GB	UD	HB	HE															UD		KB	KB	
27,000 pF	273		F	G	J	K	M	FB	FB	FB	FB	FB	UD				GB	GB	UD	HB	HE															UD		KB	KB	
33,000 pF	333		F	G	J	K	M	FB	FB	FB	FB	FB	UD				GB	GB	UD	HB	HG															UD		KB	KE	
39,000 pF	393		F	G	J	K	M	FB	FB	FB	FB	FE	UD				GB	GB	UD																		UD			
47,000 pF	473		F	G	J	K	M	FB	FB	FB	FB	FE	UD				GB	GB	UD																		UD			
56,000 pF	563		F	G	J	K	M	FB	FB	FB	FB	FF					GB	GB	UD																		UD			
68,000 pF	683		F	G	J	K	M	FB	FB	FB	FC	FG					GB	GB	UD																		UD			
82,000 pF	823		F	G	J	K	M	FC	FC	FC	FF	FH					GB	GB	UD																		UD			
0.10 μF	104		F	G	J	K	M	FE	FE	FE	FG	FM					GB	GD	UD																	UD				
0.12 μF	124		F	G	J	K	M	FG	FG	FG	FH						GB	GH																			UD			
0.15 μF	154		F	G	J	K	M	FH	FH	FH	FM						GD	GN																			UD			
0.18 μF	184		F	G	J	K	M	FJ	FJ	FJ							GH																				UD			
0.22 μF	224		F	G	J	K	M	FK	FK	FK							GK																				UD			
0.27 μF	274		F	G	J	K	M																																	
0.33 μF	334		F	G	J	K	M																																	
0.47 μF	474		F	G	J	K	M																																	
0.56 μF	564		F	G	J	K	M																																	
0.68 μF	684		F	G	J	K	M																																	
0.82 μF	824		F	G	J	K	M																																	
1.0 μF	105		F	G	J	K	M																																	
Cap	Cap Code	Voltage DC						10	16	25	50	100	200	50	100	200	50	100	200	50	100	200	50	100	200	50	100	200	50	100	200									
		Voltage Code						8	4	3	5	1	2	5	1	2	5	1	2	5	1	2	3	1	2	5	1	2												
		Series						C1210						C1808			C1812			C1825			C2220			C2225														

UD = Under Development

KEMET reserves the right to substitute product with an improved temperature characteristic, tighter capacitance tolerance and/or higher voltage capability within the same form factor (configuration and dimensions).

These products are protected under US Patents 7,172,985 & 7,670,981, other patents pending, and any foreign counterparts.

Commercial "L" Series, SnPb Termination, X7R Dielectric 6.3VDC-250VDC (Commercial Grade)

Overview

KEMET's Commercial "L" Series with Tin/Lead Termination surface mount capacitors in X7R dielectric are designed to meet the needs of critical applications where tin/lead end metallization is required. KEMET's tin/lead electroplating process is designed to meet a 5% minimum lead content and address concerns for a more robust and reliable lead containing termination system. As the bulk of the electronics industry moves towards RoHS compliance, KEMET continues to provide tin/lead terminated products for military, aerospace and industrial applications and will ensure customers have a stable and long-term source of supply.

KEMET's X7R dielectric features a 125°C maximum operating

temperature and is considered "temperature stable." The Electronics Components, Assemblies & Materials Association (EIA) characterizes X7R dielectric as a Class II material. Components of this classification are fixed, ceramic dielectric capacitors suited for bypass and decoupling applications or for frequency discriminating circuits where Q and stability of capacitance characteristics are not critical. X7R exhibits a predictable change in capacitance with respect to time and voltage and boasts a minimal change in capacitance with reference to ambient temperature. Capacitance change is limited to $\pm 15\%$ from -55°C to $+125^{\circ}\text{C}$.

Benefits

- -55°C to $+125^{\circ}\text{C}$ operating temperature range
- Temperature stable dielectric
- Reliable and robust termination system
- EIA 0402, 0603, 0805, 1206, 1210, 1808, 1812, 1825, 2220 and 2225 case sizes
- DC voltage ratings of 6.3V, 10V, 16V, 25V, 50V, 100V, 200V and 250V
- Capacitance offerings ranging from 150pF to 22 μF
- Available capacitance tolerances of $\pm 5\%$, $\pm 10\%$ and $\pm 20\%$
- Non-polar device, minimizing installation concerns
- SnPb plated termination finish (5% min)
- Flexible termination option available upon request

- Available for other surface mount products, additional dielectrics and higher voltage ratings upon request

Applications

Typical applications include military, aerospace and other high reliability applications.

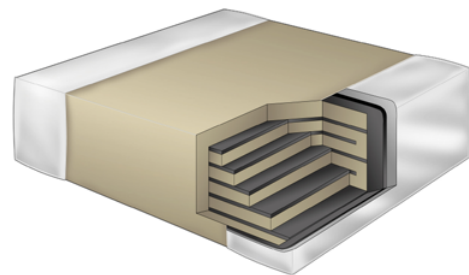

Ordering Information

C	1206	C	226	K	8	R	A	C	TU
Ceramic	Case Size (L" x W")	Specification/ Series	Capacitance Code (pF)	Capacitance Tolerance	Voltage	Dielectric	Failure Rate/ Design	Termination Finish ¹	Packaging/Grade (C-Spec) ²
	0402 0603 0805 1206 1210 1808 1812 1825 2220 2225	C = Standard	2 Sig. Digits + Number of Zeros	J = $\pm 5\%$ K = $\pm 10\%$ M = $\pm 20\%$	9 = 6.3V 8 = 10V 4 = 16V 3 = 25V 6 = 35V 5 = 50V 1 = 100V 2 = 200V A = 250V	R = X7R	A = N/A	L = SnPb (5% min)	Blank = Bulk TU = 7" Reel Unmarked TM = 7" Reel Marked

¹ Additional termination finish options may be available. Contact KEMET for details

² Additional reeling or packaging options may be available. Contact KEMET for details.

Dimensions – Millimeters (Inches)

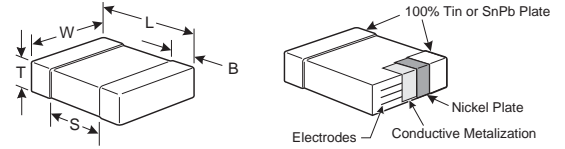

EIA Size Code	Metric Size Code	L Length	W Width	T Thickness	B Bandwidth	S Separation Min.	Mounting Technique
0402	1005	1.00 (.040) ± 0.05 (.002)	0.50 (.020) ± 0.05 (.002)	See Table 2 for Thickness	0.30 (.012) ± 0.10 (.004)	0.30 (.012)	Solder Reflow Only
0603	1608	1.60 (.063) ± 0.15 (.006)	0.80 (.032) ± 0.15 (.006)		0.35 (.014) ± 0.15 (.006)	0.70 (.028)	Solder Wave or Solder Reflow
0805	2012	2.00 (.079) ± 0.20 (.008)	1.25 (.049) ± 0.20 (.008)		0.50 (0.02) ± 0.25 (.010)	0.75 (.030)	
1206	3216	3.20 (.126) ± 0.20 (.008)	1.60 (.063) ± 0.20 (.008)		0.50 (0.02) ± 0.25 (.010)	N/A	Solder Reflow Only
1210	3225	3.20 (.126) ± 0.20 (.008)	2.50 (.098) ± 0.20 (.008)		0.60 (.024) ± 0.35 (.014)		
1808	4520	4.70 (.185) ± 0.50 (.020)	2.00 (.079) ± 0.20 (.008)		0.60 (.024) ± 0.35 (.014)		
1812	4532	4.50 (.177) ± 0.30 (.012)	3.20 (.126) ± 0.30 (.012)		0.60 (.024) ± 0.35 (.014)		
1825	4564	4.50 (.177) ± 0.30 (.012)	6.40 (.252) ± 0.40 (.016)		0.60 (.024) ± 0.35 (.014)		
2220	5650	5.70 (.224) ± 0.40 (.016)	5.00 (.197) ± 0.40 (.016)		0.60 (.024) ± 0.35 (.014)		
2225	5664	5.60 (.220) ± 0.40 (.016)	6.40 (.248) ± 0.40 (.016)		0.60 (.024) ± 0.35 (.014)		

Qualification/Certification

Commercial grade products are subject to internal qualification. Details regarding test methods and conditions are referenced in Table 4, Performance and Reliability.

Environmental Compliance

These devices do not meet RoHS criteria due to the concentration of Pb containment in the termination finish

Electrical Parameters/Characteristics

Item	Parameters/Characteristics
Operating Temperature Range	-55°C to +125°C
Capacitance Change with Reference to +25°C and 0 Vdc Applied (TCC)	±15%
Aging Rate (Max % Cap Loss/Decade Hour)	3.0%
Dielectric Withstanding Voltage	250% of rated voltage (5 ± 1 seconds and charge/discharge not exceeding 50mA)
Dissipation Factor (DF) Maximum Limits @ 25°C	5%(10V), 3.5%(16V & 25V) and 2.5%(50V to 250V)
Insulation Resistance (IR) Limit @ 25°C	See Insulation Resistance Limit Table (Rated voltage applied for 120 ± 5 secs @ 25°C)

Regarding Aging Rate: Capacitance measurements (including tolerance) are indexed to a referee time of 1000 Hours.

To obtain IR limit, divide $M\Omega\text{-}\mu\text{F}$ value by the capacitance and compare to $G\Omega$ limit. Select the lower of the two limits.

Capacitance and Dissipation Factor (DF) measured under the following conditions:

1kHz ± 50Hz and 1.0 ± 0.2 Vrms if capacitance ≤ 10μF

120Hz ± 10Hz and 0.5 ± 0.1 Vrms if capacitance > 10μF

Note: When measuring capacitance it is important to ensure the set voltage level is held constant. The HP4284 & Agilent E4980 have a feature known as Automatic Level Control (ALC). The ALC feature should be switched to "ON". Insulation Resistance Limit Table

Post Environmental Limits

High Temperature Life, Biased Humidity, Moisture Resistance					
Dielectric	Rated DC Voltage	Capacitance Value	DF (%)	Cap Shift	IR
X7R	>25	All	3.0	± 20%	10% of Initial Limit
	16 / 25		5.0		
	< 16		7.5		

Insulation Resistance Limit Table

EIA Case Size	1000 megohm microfarads or 100GΩ	500 megohm microfarads or 10GΩ
0201	N/A	ALL
0402	< .012μF	≥ .012μF
0603	< .047μF	≥ .047μF
0805	< .047μF	≥ .047μF
1206	< 0.22μF	≥ 0.22μF
1210	< 0.39μF	≥ 0.39μF
1808	ALL	N/A
1812	< 2.2μF	≥ 2.2μF
1825	ALL	N/A
2220	< 10μF	≥ 10μF
2225	ALL	N/A

Table 1A – SnPb Termination, X7R Dielectric, (0402 - 1206 Case Sizes)

Cap	Cap Code	Series			C0402					C0603						C0805									C1206									
		Voltage Code			9	8	4	3	5	9	8	4	3	5	1	2	9	8	4	3	6	5	1	2	A	9	8	4	3	6	5	1	2	A
		Voltage DC			6.3	10	16	25	50	6.3	10	16	25	50	100	200	6.3	10	16	25	35	50	100	200	250	6.3	10	16	25	35	50	100	200	250
Cap Tolerance		Product Availability and Chip Thickness Codes - See Table 2 for Chip Thickness Dimensions																																
150 pF	151	J	K	M	BB	BB	BB	BB	BB							DC	DC	DC	DC	DC	DC	DC	DC											
180 pF	181	J	K	M	BB	BB	BB	BB	BB	CB	CB	CB	CB	CB	CB	DC	DC	DC	DC	DC	DC	DC	DC											
220 pF	221	J	K	M	BB	BB	BB	BB	BB	CB	CB	CB	CB	CB	CB	DC	DC	DC	DC	DC	DC	DC	DC											
270 pF	271	J	K	M	BB	BB	BB	BB	BB	CB	CB	CB	CB	CB	CB	DC	DC	DC	DC	DC	DC	DC	DC											
330 pF	331	J	K	M	BB	BB	BB	BB	BB	CB	CB	CB	CB	CB	CB	DC	DC	DC	DC	DC	DC	DC	DC											
390 pF	391	J	K	M	BB	BB	BB	BB	BB	CB	CB	CB	CB	CB	CB	DC	DC	DC	DC	DC	DC	DC	DC											
470 pF	471	J	K	M	BB	BB	BB	BB	BB	CB	CB	CB	CB	CB	CB	DC	DC	DC	DC	DC	DC	DC	DC											
560 pF	561	J	K	M	BB	BB	BB	BB	BB	CB	CB	CB	CB	CB	CB	DC	DC	DC	DC	DC	DC	DC	DC											
680 pF	681	J	K	M	BB	BB	BB	BB	BB	CB	CB	CB	CB	CB	CB	DC	DC	DC	DC	DC	DC	DC	DC											
820 pF	821	J	K	M	BB	BB	BB	BB	BB	CB	CB	CB	CB	CB	CB	DC	DC	DC	DC	DC	DC	DC	DC											
1,000 pF	102	J	K	M	BB	BB	BB	BB	BB	CB	CB	CB	CB	CB	CB	DC	DC	DC	DC	DC	DC	DC	DC	EB	EB	EB	EB	EB	EB	EB	EB	EB	EB	
1,200 pF	122	J	K	M	BB	BB	BB	BB	BB	CB	CB	CB	CB	CB	CB	DC	DC	DC	DC	DC	DC	DC	DC	EB	EB	EB	EB	EB	EB	EB	EB	EB	EB	
1,500 pF	152	J	K	M	BB	BB	BB	BB	BB	CB	CB	CB	CB	CB	CB	DC	DC	DC	DC	DC	DC	DC	DC	EB	EB	EB	EB	EB	EB	EB	EB	EB	EB	
1,800 pF	182	J	K	M	BB	BB	BB	BB	BB	CB	CB	CB	CB	CB	CB	DC	DC	DC	DC	DC	DC	DC	DC	EB	EB	EB	EB	EB	EB	EB	EB	EB	EB	
4,700 pF	222	J	K	M	BB	BB	BB	BB	BB	CB	CB	CB	CB	CB	CB	DC	DC	DC	DC	DC	DC	DC	DC	EB	EB	EB	EB	EB	EB	EB	EB	EB	EB	
2,700 pF	272	J	K	M	BB	BB	BB	BB	BB	CB	CB	CB	CB	CB	CB	DC	DC	DC	DC	DC	DC	DC	DC	EB	EB	EB	EB	EB	EB	EB	EB	EB	EB	
3,300 pF	332	J	K	M	BB	BB	BB	BB	BB	CB	CB	CB	CB	CB	CB	DC	DC	DC	DC	DC	DC	DC	DC	EB	EB	EB	EB	EB	EB	EB	EB	EB	EB	
3,900 pF	392	J	K	M	BB	BB	BB	BB	BB	CB	CB	CB	CB	CB	CB	DC	DC	DC	DC	DC	DC	DC	DC	EB	EB	EB	EB	EB	EB	EB	EB	EB	EB	
4,700 pF	472	J	K	M	BB	BB	BB	BB	BB	CB	CB	CB	CB	CB	CB	DC	DC	DC	DC	DC	DC	DC	DC	EB	EB	EB	EB	EB	EB	EB	EB	EB	EB	
5,600 pF	562	J	K	M	BB	BB	BB	BB	BB	CB	CB	CB	CB	CB	CB	DC	DC	DC	DC	DC	DC	DC	DC	EB	EB	EB	EB	EB	EB	EB	EB	EB	EB	
6,800 pF	682	J	K	M	BB	BB	BB	BB	BB	CB	CB	CB	CB	CB	CB	DC	DC	DC	DC	DC	DC	DC	DC	EB	EB	EB	EB	EB	EB	EB	EB	EB	EB	
8,200 pF	822	J	K	M	BB	BB	BB	BB	BB	CB	CB	CB	CB	CB	CB	DC	DC	DC	DC	DC	DC	DC	DC	EB	EB	EB	EB	EB	EB	EB	EB	EB	EB	
10,000 pF	103	J	K	M	BB	BB	BB	BB	BB	CB	CB	CB	CB	CB	CB	DC	DC	DC	DC	DC	DC	DC	DC	EB	EB	EB	EB	EB	EB	EB	EB	EB	EB	
12,000 pF	123	J	K	M	BB	BB	BB	BB	BB	CB	CB	CB	CB	CB	CB	DC	DC	DC	DC	DC	DC	DC	DC	EB	EB	EB	EB	EB	EB	EB	EB	EB	EB	
15,000 pF	153	J	K	M	BB	BB	BB	BB	BB	CB	CB	CB	CB	CB	CB	DC	DC	DC	DC	DC	DC	DD	DC	EB	EB	EB	EB	EB	EB	EB	EB	EB	EB	
18,000 pF	183	J	K	M	BB	BB	BB	BB	BB	CB	CB	CB	CB	CB	CB	DC	DC	DC	DC	DC	DC	DD	DC	EB	EB	EB	EB	EB	EB	EB	EB	EB	EB	
22,000 pF	223	J	K	M	BB	BB	BB	BB	BB	CB	CB	CB	CB	CB	CB	DC	DC	DC	DC	DC	DC	DD	DC	EB	EB	EB	EB	EB	EB	EB	EB	EB	EB	
27,000 pF	273	J	K	M	BB	BB	BB	BB	BB	CB	CB	CB	CB	CB	CB	DC	DC	DC	DC	DC	DC	DD	DE	EB	EB	EB	EB	EB	EB	EB	EB	EB	EB	
33,000 pF	333	J	K	M	BB	BB	BB	BB	BB	CB	CB	CB	CB	CB	CB	DC	DC	DC	DC	DC	DC	DD	DE	EB	EB	EB	EB	EB	EB	EB	EB	EB	EB	
39,000 pF	393	J	K	M	BB	BB	BB	BB	BB	CB	CB	CB	CB	CB	CB	DC	DC	DC	DC	DC	DC	DD	DE	EB	EB	EB	EB	EB	EB	EB	EB	EB	EB	
47,000 pF	473	J	K	M	BB	BB	BB	BB	BB	CB	CB	CB	CB	CB	CB	DC	DC	DC	DC	DC	DC	DE	DG	EB	EB	EB	EB	EB	EB	EB	EB	EB	EB	
56,000 pF	563	J	K	M	BB	BB	BB	BB	BB	CB	CB	CB	CB	CB	CB	DD	DD	DD	DD	DD	DD	DE	DG	EB	EB	EB	EB	EB	EB	EB	EB	EB	EB	
68,000 pF	683	J	K	M	BB	BB	BB	BB	BB	CB	CB	CB	CB	CB	CB	DD	DD	DD	DD	DD	DD	DE		EB	EB	EB	EB	EB	EB	EB	EB	EB	EB	
82,000 pF	823	J	K	M	BB	BB	BB	BB	BB	CB	CB	CB	CB	CB	CB	DD	DD	DD	DD	DD	DD	DE		EB	EB	EB	EB	EB	EB	EB	EB	EB	EB	
0.10 µF	104	J	K	M	BB	BB	BB	BB	BB	CB	CB	CB	CB	CB	CB	DD	DD	DD	DD	DD	DD	DE		EB	EB	EB	EB	EB	EB	EB	EB	EB	EM	
0.12 µF	124	J	K	M						CB	CB	CB	CB	CB	CB	DC	DC	DC	DC	DD	DD	DG		EC	EC	EC	EC	EC	EC	EC	EC	EG		
0.15 µF	154	J	K	M						CB	CB	CB	CB	CD		DC	DC	DC	DC	DD	DD	DG		EC	EC	EC	EC	EC	EC	EC	EC	EG		
0.18 µF	184	J	K	M						CB	CB	CB	CB			DC	DC	DC	DC	DD	DG	DG		EC	EC	EC	EC	EC	EC	EC	EC			
0.22 µF	224	J	K	M						CB	CB	CB	CD	UD		DC	DC	DC	DC	DD	DG	DG		EC	EC	EC	EC	EC	EC	EC	EC			
0.27 µF	274	J	K	M						CB	CB	CB				DD	DD	DD	DD	DD	DD			EB	EB	EB	EB	EB	EC	EC	EM			
0.33 µF	334	J	K	M						CB	CB	CB				DG	DG	DG	DG	DD	DD			EB	EB	EB	EB	EB	EC	EC	EG			
0.39 µF	394	J	K	M						CB	CB	CB				DG	DG	DG	DG	DE	DE			EB	EB	EB	EB	EB	EC	EC	EG			
0.47 µF	474	J	K	M						CB	CB	CB				DD	DD	DD	DD	DE	DE			EC	EC	EC	EC	EC	EC	EC	EC	EG		
0.56 µF	564	J	K	M												DD	DD	DD	DG	DH	DH			ED	ED	ED	ED	ED	EC	EC				
0.68 µF	684	J	K	M												DD	DD	DD	DG	DH	DH			EE	EE	EE	EE	ED	ED					
0.82 µF	824	J	K	M												DD	DD	DD	DG					EF	EF	EF	EF	ED	ED					
1.0 µF	105	J	K	M						CC ²						DD	DD	DD	DG	UD				EF	EF	EF	EG	ED	ED					
1.2 µF	125	J	K	M												DE	DE	DE						ED	ED	ED	EG	EH	EH					
1.5 µF	155	J	K	M												DG	DG	DG						ED	ED	ED	EG	EH	EH					
1.8 µF	185	J	K	M												DG	DG	DG						EF	EF	EF	EH	EH						
2.2 µF	225	J	K	M												DG	DG	DG						ED	ED	ED	EF	EH	EH					
2.7 µF	275	J	K	M																				EN	EN	EN	EH							
3.3 µF	335	J	K	M																				ED	ED	ED	EH							
3.9 µF	395	J	K	M																				EF	EF	EF	EH							
4.7 µF	475	J	K	M																				EF	EF	EF	EH							
5.6 µF	565	J	K	M																				EH	EH	EH								
6.8 µF	685	J	K	M																				EH	EH	EH								
8.2 µF	825	J	K	M																				EH	EH	EH								
10 µF	106	J	K	M																				EH	EH	EH								

Table 1B – SnPb Termination, X7R Dielectric, (1210 - 2225 Case Sizes)

Cap	Cap Code	Series		C1210								C1808			C1812					C1825				C2220					C2225				
		Voltage Code		9	8	4	3	5	1	2	A	5	1	2	3	5	1	2	A	5	1	2	A	3	5	1	2	A	5	1	2	A	
		Voltage DC		6.3	10	16	25	50	100	200	250	50	100	200	25	50	100	200	250	50	100	200	250	25	50	100	200	250	50	100	200	250	
		Cap Tolerance		Product Availability and Chip Thickness Codes - See Table 2 for Chip Thickness Dimensions																													
2,200 pF	222	J	K	M	FB	FB	FB	FB	FB	FB	FB	FB																					
2,700 pF	272	J	K	M	FB	FB	FB	FB	FB	FB	FB	FB																					
3,300 pF	332	J	K	M	FB	FB	FB	FB	FB	FB	FB	FB																					
3,900 pF	392	J	K	M	FB	FB	FB	FB	FB	FB	FB	FB																					
4,700 pF	472	J	K	M	FB	FB	FB	FB	FB	FB	FB	FB	LD	LD	LD																		
5,600 pF	562	J	K	M	FB	FB	FB	FB	FB	FB	FB	FB	LD	LD	LD																		
6,800 pF	682	J	K	M	FB	FB	FB	FB	FB	FB	FB	FB	LD	LD	LD	LD					GB	GB	GB	GB	GB								
8,200 pF	822	J	K	M	FB	FB	FB	FB	FB	FB	FB	FB	LD	LD	LD	LD					GB	GB	GB	GB	GB								
10,000 pF	103	J	K	M	FB	FB	FB	FB	FB	FB	FB	FB	LD	LD	LD	LD					GB	GB	GB	GB	GB								
12,000 pF	123	J	K	M	FB	FB	FB	FB	FB	FB	FB	FB	LD	LD	LD	LD					GB	GB	GB	GB	GB								
15,000 pF	153	J	K	M	FB	FB	FB	FB	FB	FB	FB	FB	LD	LD	LD	LD					GB	GB	GB	GB	GB								
18,000 pF	183	J	K	M	FB	FB	FB	FB	FB	FB	FB	FB	LD	LD	LD	LD					GB	GB	GB	GB	GB								
22,000 pF	223	J	K	M	FB	FB	FB	FB	FB	FB	FB	FB	LD	LD	LD	LD					GB	GB	GB	GB	GB	HB	HB	HB	HB				
27,000 pF	273	J	K	M	FB	FB	FB	FB	FB	FB	FB	FB	LD	LD	LD	LD					GB	GB	GB	GB	GB	HB	HB	HB	HB				
33,000 pF	333	J	K	M	FB	FB	FB	FB	FB	FB	FB	FB	LD	LD	LD	LD					GB	GB	GB	GB	GB	HB	HB	HB	HB				
39,000 pF	393	J	K	M	FB	FB	FB	FB	FB	FB	FB	FB	LD	LD	LD	LD					GB	GB	GB	GB	GB	HB	HB	HB	HB				
47,000 pF	473	J	K	M	FB	FB	FB	FB	FB	FB	FB	FB	LD	LD	LD	LD					GB	GB	GB	GB	GB	HB	HB	HB	HB	KC	KC	KC	KC
56,000 pF	563	J	K	M	FB	FB	FB	FB	FB	FB	FB	FB	LD	LD	LD	LD					GB	GB	GB	GB	GB	HB	HB	HB	HB	KC	KC	KC	KC
68,000 pF	683	J	K	M	FB	FB	FB	FB	FB	FB	FB	FB	LD	LD	LD	LD					GB	GB	GB	GB	GB	HB	HB	HB	HB	KC	KC	KC	KC
82,000 pF	823	J	K	M	FB	FB	FB	FB	FB	FB	FB	FB	LD	LD	LD	LD					GB	GB	GB	GB	GB	HB	HB	HB	HB	JC	JC	JC	JC
0.10 µF	104	J	K	M	FB	FB	FB	FB	FB	FB	FB	FB	LD	LD	LD	LD					GB	GB	GB	GB	GB	HB	HB	HB	HB	JC	JC	JC	JC
0.12 µF	124	J	K	M	FB	FB	FB	FB	FB	FB	FB	FB	LD	LD	LD	LD					GB	GB	GB	GB	GB	HB	HB	HB	HB	JC	JC	JC	JC
0.15 µF	154	J	K	M	FC	FC	FC	FC	FC	FC	FD		LD	LD	LD	LD					GB	GB	GB	GE	GE	HB	HB	HB	HB	JC	JC	JC	JC
0.18 µF	184	J	K	M	FC	FC	FC	FC	FC	FD			LD	LD	LD	LD					GB	GB	GB	GF	GF	HB	HB	HB	HB	JC	JC	JC	JC
0.22 µF	224	J	K	M	FC	FC	FC	FC	FC	FD			LD	LD	LD	LD					GB	GB	GB	GG	GG	HB	HB	HB	HB	JC	JC	JC	JC
0.27 µF	274	J	K	M	FC	FC	FC	FC	FC	FD											GB	GB	GG	GG	GG	HB	HB	HB	HB	JC	JC	JC	JC
0.33 µF	334	J	K	M	FD	FD	FD	FD	FD	FD											GB	GB	GG	GG	GG	HB	HB	HB	HB	JC	JC	JC	JC
0.39 µF	394	J	K	M	FD	FD	FD	FD	FD	FD											GB	GB	GG	GG	GG	HB	HB	HD	HD	JC	JC	JC	JC
0.47 µF	474	J	K	M	FD	FD	FD	FD	FD	FD											GB	GB	GG	GG	GG	HB	HB	HD	HD	JC	JC	JC	JC
0.56 µF	564	J	K	M	FD	FD	FD	FD	FD	FF											GC	GC	GG			HB	HD	HD	HD	JC	JC	JC	JC
0.68 µF	684	J	K	M	FD	FD	FD	FD	FD	FG											GC	GC	GG			HB	HD	HD	HD	JC	JC	JD	JD
0.82 µF	824	J	K	M	FF	FF	FF	FF	FF	FL											GE	GE	GG			HB	HF	HF	HF	JC	JC	JF	JF
1.0 µF	105	J	K	M	FH	FH	FH	FH	FH	FM											GE	GE	GG			HB	HF	HF	HF	JC	JC	JF	JF
1.2 µF	125	J	K	M	FH	FH	FH	FH	FG																HB				JC	JC	JF	JF	
1.5 µF	155	J	K	M	FH	FH	FH	FH	FG																HC				JC	JC			
1.8 µF	185	J	K	M	FH	FH	FH	FH	FG																HD				JD	JD			
2.2 µF	225	J	K	M	FJ	FJ	FJ	FJ	FG																HF				JF	JF			
2.7 µF	275	J	K	M	FE	FE	FE	FG	FH																								
3.3 µF	335	J	K	M	FF	FF	FF	FM	FM																								
3.9 µF	395	J	K	M	FG	FG	FG	FG	FK																								
4.7 µF	475	J	K	M	FC	FC	FC	FG	FS																								
5.6 µF	565	J	K	M	FF	FF	FF	FH																									
6.8 µF	685	J	K	M	FG	FG	FG	FM																									
8.2 µF	825	J	K	M	FH	FH	FH	FK																									
10 µF	106	J	K	M	FH	FH	FH	FS																									
12 µF	126	J	K	M																													
15 µF	156	J	K	M																													
18 µF	186	J	K	M																													
22 µF	226	J	K	M	FS	FS																											
47 µF	476	J	K	M																													

Commercial Off-the-Shelf (COTS) for Higher Reliability Applications, C0G Dielectric, 10VDC-200VDC

Overview

KEMET's COTS program is an extension of KEMET knowledge of high reliability test regimes and requirements. KEMET regularly supplies "up-screened" products by working with customer drawings and imposing specified design and test requirements. The COTS program offers the same high quality and high reliability components as up-screened products, but at a lower cost to the customer. This is accomplished by eliminating the need for customer-specific drawings to achieve the reliability level required for customer applications. A series of tests and inspections have been selected to provide the accelerated conditioning and 100% screening necessary to eliminate infant mortal failures from the population.

KEMET's C0G dielectric features a 125°C maximum operating temperature and is considered "stable." The Electronics Components, Assemblies & Materials Association (EIA) characterizes C0G dielectric as a Class I material. Components of this classification are temperature compensating and are suited for resonant circuit applications or those where Q and stability of capacitance characteristics are required. C0G exhibits no change in capacitance with respect to time and voltage and boasts a negligible change in capacitance with reference to ambient temperature. Capacitance change is limited to ±30ppm/°C from -55°C to +125°C.

All COTS testing includes voltage conditioning and post-electrical testing as per MIL-PRF-55681. For enhanced reliability, KEMET also provides the following test level options and conformance certifications:

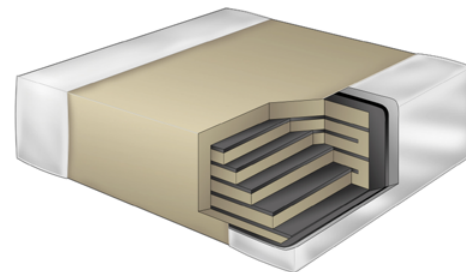
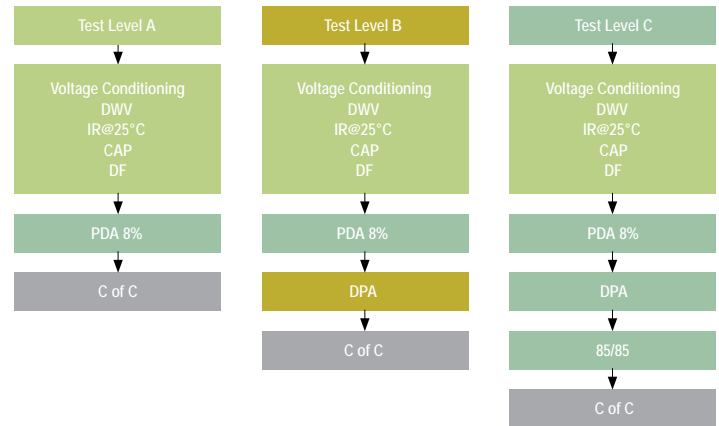

Ordering Information

C	1206	T	104	K	5	G	A	C	TU
Ceramic	Case Size (L" x W")	Specification/ Series	Capacitance Code (pF)	Capacitance Tolerance ¹	Voltage	Dielectric	Failure Rate/Design	Termination Finish ²	Packaging/Grade (C-Spec) ³
	0402 0603 0805 1206 1210 1812 2220	T = COTS	2 Sig. Digits + Number of Zeros Use 9 for 1.0 - 9.9pF Use 8 for 0.5 - .99pF ex. 2.2pF = 229 ex. 0.5pF = 508	C = ±0.25pF D = ±0.5pF F = ± 1% G = ±2% J = ±5% K = ±10% M = ±20%	8 = 10V 4 = 16V 3 = 25V 6 = 35V 5 = 50V 1 = 100V 2 = 200V	G = C0G	A = Group A Testing per MIL-PRF-55681 PDA 8% B = Group A Testing per MIL-PRF-55681 PDA 8%, DPA per EIA-469 C = Group A Testing per MIL-PRF-55681 PDA 8%, DPA per EIA-469, Humidity per MIL-STD-202, Method 103, Condition A	C = 100% Matte Sn L = SnPb (5% min)	Blank = Bulk TU = 7" Reel Unmarked TM = 7" Reel Marked

¹ Additional capacitance tolerance offerings may be available. Contact KEMET for details.

² Additional termination finish options may be available. Contact KEMET for details.

³ Additional reeling or packaging options may be available. Contact KEMET for details.

Dimensions – Millimeters (Inches)

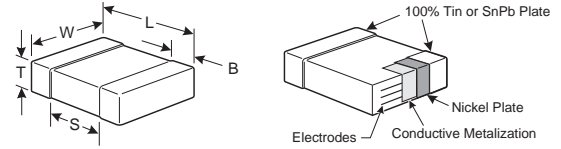

EIA Size Code	Metric Size Code	L Length	W Width	T Thickness	B Bandwidth	S Separation Min.	Mounting Technique
0402	1005	1.00 (.040) ± 0.05 (.002)	0.50 (.020) ± 0.05 (.002)	See Table 2 for Thickness	0.30 (.012) ± 0.10 (.004)	0.30 (.012)	Solder Reflow Only
0603	1608	1.60 (.063) ± 0.15 (.006)	0.80 (.032) ± 0.15 (.006)		0.35 (.014) ± 0.15 (.006)	0.70 (.028)	Solder Wave or Solder Reflow
0805	2012	2.00 (.079) ± 0.20 (.008)	1.25 (.049) ± 0.20 (.008)		0.50 (0.02) ± 0.25 (.010)	0.75 (.030)	
1206	3216	3.20 (.126) ± 0.20 (.008)	1.60 (.063) ± 0.20 (.008)		0.50 (0.02) ± 0.25 (.010)	N/A	Solder Reflow Only
1210	3225	3.20 (.126) ± 0.20 (.008)	2.50 (.098) ± 0.20 (.008)		0.50 (0.02) ± 0.25 (.010)		
1812	4532	4.50 (.177) ± 0.30 (.012)	3.20 (.126) ± 0.30 (.012)		0.60 (.024) ± 0.35 (.014)		
2220	5650	5.70 (.224) ± 0.40 (.016)	5.00 (.197) ± 0.40 (.016)		0.60 (.024) ± 0.35 (.014)		

Benefits

- -55°C to +125°C operating temperature range
- Voltage conditioning and post-electrical testing per MIL-PRF-55681, Paragraph 4.8.3.1, Standard Voltage Conditioning
- Destructive Physical Analysis (DPA) per EIA-469
- Humidity, steady state, low voltage (85/85) per MIL-STD 202, Method 103, Condition A
- Certificate of compliance
- RoHS compliant (excluding SnPb end metallization option)
- EIA 0201, 0402, 0603, 0805, 1206, 1210, 1812, 1825, 2220 and 2225 case sizes
- DC voltage ratings of 10V, 16V, 25V, 50V, 100V and 200V
- Capacitance offerings ranging from 0.5pF up to 0.47µF
- Available capacitance tolerances of ±0.25pF, ±0.5pF, ±1%, ±2%, ±5%, ±10% and ±20%
- No piezoelectric noise
- Extremely low ESR and ESL
- High thermal stability
- High ripple current capability
- Preferred capacitance solution at line frequencies and into the MHz range
- No capacitance change with respect to applied rated DC voltage
- Negligible capacitance change with respect to temperature
- No capacitance decay with time
- Non-polar device, minimizing installation concerns
- SnPb end metallization option available upon request (5% min)

Applications

Typical applications include military, space quality and high reliability electronics.

Qualification/Certification

Commercial grade products are subject to internal qualification. Details regarding test methods and conditions are referenced in Table 4, Performance and Reliability.

Environmental Compliance

RoHS compliant (excluding SnPb termination finish option)

Electrical Parameters/Characteristics

Item	Parameters/Characteristics
Operating Temperature Range	-55°C to +125°C
Capacitance Change with Reference to +25°C and 0 Vdc Applied (TCC)	±30PPM/°C
Aging Rate (Max % Cap Loss/Decade Hour)	0%
Dielectric Withstanding Voltage	250% of rated voltage (5 ± 1 seconds and charge/discharge not exceeding 50mA)
Dissipation Factor (DF) Maximum Limit @ 25°C	0.1%
Insulation Resistance (IR) Limit @ 25°C	1000 megohm microfarads or 100GΩ (Rated voltage applied for 120 ± 5 secs @ 25°C)

To obtain IR limit, divide MΩ-μF value by the capacitance and compare to GΩ limit. Select the lower of the two limits.

Capacitance and Dissipation Factor (DF) measured under the following conditions:

1MHz ± 100kHz and 1.0Vrms ± 0.2V if capacitance ≤1000pF

1kHz ± 50Hz and 1.0Vrms ± 0.2V if capacitance >1000pF

Note: When measuring capacitance it is important to ensure the set voltage level is held constant. The HP4284 & Agilent E4980 have a feature known as Automatic Level Control (ALC). The ALC feature should be switched to "ON".

Post Environmental Limits

High Temperature Life, Biased Humidity, Moisture Resistance					
Dielectric	Rated DC Voltage	Capacitance Value	DF (%)	Cap Shift	IR
C0G	All	All	0.5	0.3% or ± 0.25 pF	10% of Initial Limit

Table 1A – (COTS) COG Dielectric, (0402 - 1206 Case Sizes)

Cap	Cap Code	Series		C0402						C0603						C0805						C1206							
		Voltage Code		8	4	3	5	1	2	8	4	3	5	1	2	8	4	3	5	1	2	8	4	3	5	1	2		
		Voltage DC		10	16	25	50	100	200	10	16	25	50	100	200	10	16	25	50	100	200	10	16	25	50	100	200		
		Cap Tolerance		Product Availability and Chip Thickness Codes See Table 2 for Chip Thickness Dimensions																									
0.5-0.75 pF	508-758	C	D																										
1.0-2.4 pF	109-249	C	D																										
2.7-5.1 pF	279-519	C	D																										
5.6-9.1 pF	569-919	C	D																										
10-13 pF	100-130	C	D																										
15-24 pF	150-240	C	D																										
27-36 pF	270-360	C	D																										
39-51 pF	390-510	D	F	G	J	K	M																						
56 pF	560	F	G	J	K	M																							
62 pF	620	F	G	J	K	M																							
68 pF	680	F	G	J	K	M																							
75 pF	750	F	G	J	K	M																							
82 pF	820	F	G	J	K	M																							
91 pF	910	F	G	J	K	M																							
100 pF	101	F	G	J	K	M																							
110 pF	111	F	G	J	K	M																							
120 pF	121	F	G	J	K	M																							
130 pF	131	F	G	J	K	M																							
150 pF	151	F	G	J	K	M																							
160 pF	161	F	G	J	K	M																							
180 pF	181	F	G	J	K	M																							
200 pF	201	F	G	J	K	M																							
220 pF	221	F	G	J	K	M																							
240 pF	241	F	G	J	K	M																							
270 pF	271	F	G	J	K	M																							
300 pF	301	F	G	J	K	M																							
330 pF	331	F	G	J	K	M																							
360 pF	361	F	G	J	K	M																							
390 pF	391	F	G	J	K	M																							
430 pF	431	F	G	J	K	M																							
470 pF	471	F	G	J	K	M																							
510 pF	511	F	G	J	K	M																							
560 pF	561	F	G	J	K	M																							
620 pF	621	F	G	J	K	M																							
680 pF	681	F	G	J	K	M																							
750 pF	751	F	G	J	K	M																							
820 pF	821	F	G	J	K	M																							
910 pF	911	F	G	J	K	M																							
1,000 pF	102	F	G	J	K	M																							
1,100 pF	112	F	G	J	K	M																							
1,200 pF	122	F	G	J	K	M																							
1,300 pF	132	F	G	J	K	M																							
1,500 pF	152	F	G	J	K	M																							
1,600 pF	162	F	G	J	K	M																							
1,800 pF	182	F	G	J	K	M																							
2,000 pF	202	F	G	J	K	M																							
2,200 pF	222	F	G	J	K	M																							
2,400 pF	242	F	G	J	K	M																							
2,700 pF	272	F	G	J	K	M																							
3,000 pF	302	F	G	J	K	M																							
3,300 pF	332	F	G	J	K	M																							
3,600 pF	362	F	G	J	K	M																							
3,900 pF	392	F	G	J	K	M																							
4,300 pF	432	F	G	J	K	M																							
4,700 pF	472	F	G	J	K	M																							
Cap	Cap Code	Voltage DC		10	16	25	50	100	200	10	16	25	50	100	200	10	16	25	50	100	200	10	16	25	50	100	200		
		Voltage Code		8	4	3	5	1	2	8	4	3	5	1	2	8	4	3	5	1	2	8	4	3	5	1	2		
		Series		C0402						C0603						C0805						C1206							

KEMET reserves the right to substitute product with an improved temperature characteristic, tighter capacitance tolerance and/or higher voltage capability within the same form factor (configuration and dimensions).

These products are protected under US Patents 7,172,985 & 7,670,981, other patents pending, and any foreign counterparts.

Table 1A – (COTS) C0G Dielectric, (0402 - 1206 Case Sizes) con't

Cap	Cap Code	Series		C0402						C0603						C0805						C1206												
		Voltage Code		8	4	3	5	1	2	8	4	3	5	1	2	8	4	3	5	1	2	8	4	3	5	1	2							
		Voltage DC		10	16	25	50	100	200	10	16	25	50	100	200	10	16	25	50	100	200	10	16	25	50	100	200							
		Cap Tolerance		Product Availability and Chip Thickness Codes See Table 2 for Chip Thickness Dimensions																														
5,100 pF	512	F	G	J	K	M							CB	CB	CB	CB							DE	DE	DE	DE	DC	ED	ED	ED	ED	ED		
5,600 pF	562	F	G	J	K	M							CB	CB	CB	CB							DC	DC	DC	DC	DC	ED	ED	ED	ED	ED		
6,200 pF	622	F	G	J	K	M							CB	CB	CB	CB							DC	DC	DC	DC	DC	EB	EB	EB	EB	EB		
6,800 pF	682	F	G	J	K	M							CB	CB	CB	CB							DC	DC	DC	DC	DC	EB	EB	EB	EB	EB		
7,500 pF	752	F	G	J	K	M							CB	CB	CB	CB							DC	DC	DC	DC	DC	EB	EB	EB	EB	EB		
8,200 pF	822	F	G	J	K	M							CB	CB	CB	CB							DC	DC	DC	DC	DC	EC	EC	EC	EC	EB		
9,100 pF	912	F	G	J	K	M							CB	CB	CB	CB							DC	DC	DC	DC	DC	EC	EC	EC	EC	EB		
10,000 pF	103	F	G	J	K	M							CB	CB	CB	CB							DC	DC	DC	DC	DD	ED	ED	ED	ED	EB		
12,000 pF	123	F	G	J	K	M							CB	CB	CB	CB							DC	DC	DC	DC	DE	ED	EB	EB	EB	EB		
15,000 pF	153	F	G	J	K	M							CB	CB	CB	CB							DC	DC	DC	DD	DG	EB	EB	EB	EB	EB		
18,000 pF	183	F	G	J	K	M																	DC	DC	DC	DD	EB	EB	EB	EB	EB			
22,000 pF	223	F	G	J	K	M																	DD	DD	DD	DF	EB	EB	EB	EB	EC			
27,000 pF	273	F	G	J	K	M																	DF	DF	DF	EB	EB	EB	EB	EE				
33,000 pF	333	F	G	J	K	M																	DG	DG	DG	EB	EB	EB	EB	EE				
47,000 pF	473	F	G	J	K	M																	DG	DG	DG	EC	EC	EC	EE	EH				
56,000 pF	563	F	G	J	K	M																					ED	ED	ED	EF				
68,000 pF	683	F	G	J	K	M																					EF	EF	EF	EH				
82,000 pF	823	F	G	J	K	M																					EH	EH	EH	EH				
0.10 µF	104	F	G	J	K	M																					EH	EH	EH					
Cap	Cap Code	Voltage DC		10	16	25	50	100	200	10	16	25	50	100	200	10	16	25	50	100	200	10	16	25	50	100	200							
		Voltage Code		8	4	3	5	1	2	8	4	3	5	1	2	8	4	3	5	1	2	8	4	3	5	1	2							
		Series		C0402						C0603						C0805						C1206												

Table 1B – (1210 - 2220 Case Sizes)

Cap	Cap Code	Series		C1210						C1812			C2220						
		Voltage Code		8	4	3	5	1	2	5	1	2	3	1	2				
		Voltage DC		10	16	25	50	100	200	50	100	200	50	100	200				
		Cap Tolerance		Product Availability and Chip Thickness Codes See Table 2 for Chip Thickness Dimensions															
0.5-0.75 pF	508-758	C	D																
1.0-2.4 pF	109-249	C	D							FB	FB	FB							
2.7-5.1 pF	279-519	C	D			K	M			FB	FB	FB							
5.6-9.1 pF	569-919	C	D			J	K	M			FB	FB	FB						
10-13 pF	100-130	C	D			J	K	M			FB	FB	FB						
15-24 pF	150-240	C	D	G	J	K	M			FB	FB	FB							
27-36 pF	270-360	D		G	J	K	M			FB	FB	FB							
39-51 pF	390-510	D	F	G	J	K	M			FB	FB	FB							
56-82 pF	560-820		F	G	J	K	M			FB	FB	FB							
91-180 pF	910-181		F	G	J	K	M			FB	FB	FB							
200-360 pF	201-361		F	G	J	K	M			FB	FB	FB							
390 pF	391		F	G	J	K	M			FB	FB	FB							
430 pF	431		F	G	J	K	M			FB	FB	FB							
470 pF	471		F	G	J	K	M			FB	FB	FB							
510 pF	511		F	G	J	K	M			FB	FB	FB				GB	GB	GB	
560 pF	561		F	G	J	K	M			FB	FB	FB				GB	GB	GB	
620 pF	621		F	G	J	K	M			FB	FB	FB				GB	GB	GB	
680 pF	681		F	G	J	K	M			FB	FB	FB				GB	GB	GB	
750 pF	751		F	G	J	K	M			FB	FB	FB				GB	GB	GB	
Cap	Cap Code	Voltage DC		10	16	25	50	100	200	50	100	200	50	100	200				
		Voltage Code		8	4	3	5	1	2	5	1	2	3	1	2				
		Series		C1210						C1812			C2220						

KEMET reserves the right to substitute product with an improved temperature characteristic, tighter capacitance tolerance and/or higher voltage capability within the same form factor (configuration and dimensions).

These products are protected under US Patents 7,172,985 & 7,670,981, other patents pending, and any foreign counterparts.

Table 1B – (COTS) C0G Dielectric, (1210 - 2220 Case Sizes) con't

Cap	Cap Code	Series					C1210						C1812			C2220		
		Voltage Code					8	4	3	5	1	2	5	1	2	3	1	2
		Voltage DC					10	16	25	50	100	200	50	100	200	50	100	200
		Cap Tolerance					Product Availability and Chip Thickness Codes See Table 2 for Chip Thickness Dimensions											
820 pF	821	F	G	J	K	M	FB	FB	FB	FB	FB	FB	GB	GB	GB			
910 pF	911	F	G	J	K	M	FB	FB	FB	FB	FB	FB	GB	GB	GB			
1,000 pF	102	F	G	J	K	M	FB	FB	FB	FB	FB	FB	GB	GB	GB			
1,100 pF	112	F	G	J	K	M	FB	FB	FB	FB	FB	FB	GB	GB	GB			
1,200 pF	122	F	G	J	K	M	FB	FB	FB	FB	FB	FB	GB	GB	GB			
1,300 pF	132	F	G	J	K	M	FB	FB	FB	FB	FB	FC	GB	GB	GB			
1,500 pF	152	F	G	J	K	M	FB	FB	FB	FB	FB	FE	GB	GB	GB			
1,600 pF	162	F	G	J	K	M	FB	FB	FB	FB	FB	FE	GB	GB	GB			
1,800 pF	182	F	G	J	K	M	FB	FB	FB	FB	FB	FE	GB	GB	GB			
2,000 pF	202	F	G	J	K	M	FB	FB	FB	FB	FC	FE	GB	GB	GB			
2,200 pF	222	F	G	J	K	M	FB	FB	FB	FB	FC	FG	GB	GB	GB			
2,400 pF	242	F	G	J	K	M	FB	FB	FB	FB	FC	FC						
2,700 pF	272	F	G	J	K	M	FB	FB	FB	FB	FC	FC	GB	GB	GB			
3,000 pF	302	F	G	J	K	M	FB	FB	FB	FB	FC	FF						
3,300 pF	332	F	G	J	K	M	FB	FB	FB	FB	FF	FF	GB	GB	GB			
3,600 pF	362	F	G	J	K	M	FB	FB	FB	FB	FF	FF						
3,900 pF	392	F	G	J	K	M	FB	FB	FB	FB	FF	FF	GB	GB	GB			
4,300 pF	432	F	G	J	K	M	FB	FB	FB	FB	FF	FG						
4,700 pF	472	F	G	J	K	M	FF	FF	FF	FF	FG	FG	GB	GB	GD			
5,100 pF	512	F	G	J	K	M	FB	FB	FB	FB	FG	FG						
5,600 pF	562	F	G	J	K	M	FB	FB	FB	FB	FG	FG	GB	GB	GH			
6,200 pF	622	F	G	J	K	M	FB	FB	FB	FB	FG	FG						
6,800 pF	682	F	G	J	K	M	FB	FB	FB	FB	FG	FG	GB	GB	GJ	JB	JB	
7,500 pF	752	F	G	J	K	M	FC	FC	FC	FC	FC	FC						
8,200 pF	822	F	G	J	K	M	FC	FC	FC	FC	FC	FC	GB	GH		JB	JB	
9,100 pF	912	F	G	J	K	M	FE	FE	FE	FE	FE	FE						
10,000 pF	103	F	G	J	K	M	FF	FF	FF	FF	FF	FF	GB	GH		JB	JB	
12,000 pF	123	F	G	J	K	M	FG	FG	FG	FG	FB	FB	GB	GG		JB	JB	
15,000 pF	153	F	G	J	K	M	FG	FG	FG	FG	FB	FB	GB	GB		JB	JB	
18,000 pF	183	F	G	J	K	M	FB	FB	FB	FB	FB	FB	GB	GB		JB	JB	
22,000 pF	223	F	G	J	K	M	FB	FB	FB	FB	FB	FB	GB	GB		JB	JB	
27,000 pF	273	F	G	J	K	M	FB	FB	FB	FB	FB	FB	GB	GB		JB	JB	
33,000 pF	333	F	G	J	K	M	FB	FB	FB	FB	FB	FB	GB	GB		JB	JB	
47,000 pF	473	F	G	J	K	M	FB	FB	FB	FB	FE	FE	GB	GB		JB	JB	
56,000 pF	563	F	G	J	K	M	FB	FB	FB	FB	FF	FF	GB	GB		JB	JB	
68,000 pF	683	F	G	J	K	M	FB	FB	FB	FC	FG	FG	GB	GB		JB	JB	
82,000 pF	823	F	G	J	K	M	FC	FC	FC	FF	FH	FH	GB	GB		JB	JB	
0.10 μF	104	F	G	J	K	M	FE	FE	FE	FG	FM	FM	GB	GD		JB	JB	
0.12 μF	124	F	G	J	K	M	FG	FG	FG	FH	FH	FH	GB	GH		JB	JB	
0.15 μF	154	F	G	J	K	M	FH	FH	FH	FM	FM	FM	GD	GN		JB	JB	
0.18 μF	184	F	G	J	K	M	FJ	FJ	FJ				GH			JB	JD	
0.22 μF	224	F	G	J	K	M	FK	FK	FK				GK			JB	JD	
0.27 μF	274	F	G	J	K	M										JB	JF	
0.33 μF	334	F	G	J	K	M										JD	JG	
0.47 μF	474	F	G	J	K	M										JG		
Cap	Cap Code	Voltage DC					10	16	25	50	100	200	50	100	200	50	100	200
		Voltage Code					8	4	3	5	1	2	5	1	2	3	1	2
		Series					C1210						C1812			C2220		

KEMET reserves the right to substitute product with an improved temperature characteristic, tighter capacitance tolerance and/or higher voltage capability within the same form factor (configuration and dimensions).

These products are protected under US Patents 7,172,985 & 7,670,981, other patents pending, and any foreign counterparts.

Commercial Off-the-Shelf (COTS) for Higher Reliability Applications, X7R Dielectric, 6.3VDC-200VDC

Overview

KEMET’s COTS program is an extension of KEMET knowledge of high reliability test regimes and requirements. KEMET regularly supplies “up-screened” products by working with customer drawings and imposing specified design and test requirements. The COTS program offers the same high quality and high reliability components as up-screened products, but at a lower cost to the customer. This is accomplished by eliminating the need for customer-specific drawings to achieve the reliability level required for customer applications. A series of tests and inspections have been selected to provide the accelerated conditioning and 100% screening necessary to eliminate infant mortal failures from the population.

KEMET’s X7R dielectric features a 125°C maximum operating temperature and is considered “temperature stable.” The Electronics Components, Assemblies & Materials Association (EIA) characterizes X7R dielectric as a Class II material. Components of this classification are fixed, ceramic dielectric capacitors suited for bypass and decoupling applications or for frequency discriminating circuits where Q and stability of capacitance characteristics are not critical. X7R exhibits a predictable change in capacitance with respect to time and voltage and boasts a minimal change in capacitance with reference to ambient temperature. Capacitance change is limited to ±15% from -55°C to +125°C.

All COTS testing includes voltage conditioning and post-electrical testing as per MIL-PRF-55681. For enhanced reliability, KEMET also provides the following test level options and conformance certifications:

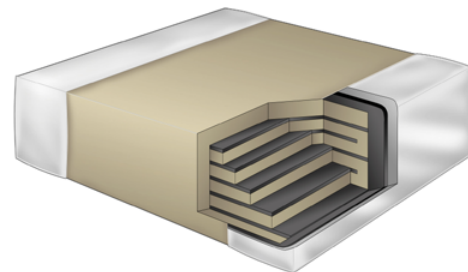
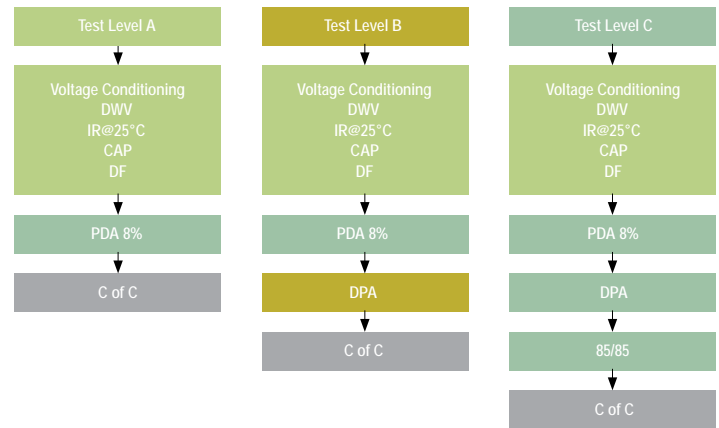

Ordering Information

C	1210	T	104	K	5	R	A	C	TU
Ceramic	Case Size (L" x W")	Specification/ Series	Capacitance Code (pF)	Capacitance Tolerance	Voltage	Dielectric	Failure Rate/Design	Termination Finish ¹	Packaging/Grade (C-Spec) ²
	0402 0603 0805 1206 1210 1812 2220	T = COTS	2 Sig. Digits + Number of Zeros	J = ±5% K = ±10% M = ±20%	9 = 6.3V 8 = 10V 4 = 16V 3 = 25V 5 = 50V 1 = 100V 2 = 200V	R = X7R	A = Group A Testing per MIL-PRF-55681 PDA 8% B= Group A Testing per MIL-PRF-55681 PDA 8%, DPA per EIA-469 C = Group A Testing per MIL-PRF-55681 PDA 8%, DPA per EIA-469, Humidity per MIL-STD-202, Method 103, Condition A	C = 100% Matte Sn L = SnPb (5% min)	Blank = Bulk TU = 7" Reel Unmarked TM = 7" Reel Marked

¹ Additional termination finish options may be available. Contact KEMET for details.

² Additional reeling or packaging options may be available. Contact KEMET for details.

Dimensions – Millimeters (Inches)

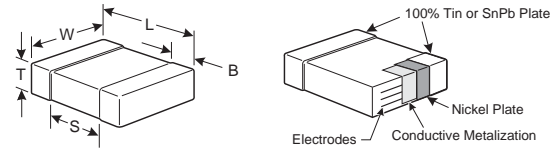

EIA Size Code	Metric Size Code	L Length	W Width	T Thickness	B Bandwidth	S Separation Min.	Mounting Technique
0402	1005	1.00 (.040) ± 0.05 (.002)	0.50 (.020) ± 0.05 (.002)	See Table 2 for Thickness	0.30 (.012) ± 0.10 (.004)	0.30 (.012)	Solder Reflow Only
0603	1608	1.60 (.063) ± 0.15 (.006)	0.80 (.032) ± 0.15 (.006)		0.35 (.014) ± 0.15 (.006)	0.70 (.028)	Solder Wave or Solder Reflow
0805	2012	2.00 (.079) ± 0.20 (.008)	1.25 (.049) ± 0.20 (.008)		0.50 (0.02) ± 0.25 (.010)	0.75 (.030)	
1206	3216	3.20 (.126) ± 0.20 (.008)	1.60 (.063) ± 0.20 (.008)		0.50 (0.02) ± 0.25 (.010)	N/A	Solder Reflow Only
1210	3225	3.20 (.126) ± 0.20 (.008)	2.50 (.098) ± 0.20 (.008)		0.50 (0.02) ± 0.25 (.010)		
1812	4532	4.50 (.177) ± 0.30 (.012)	3.20 (.126) ± 0.30 (.012)		0.60 (.024) ± 0.35 (.014)		
2220	5650	5.70 (.224) ± 0.40 (.016)	5.00 (.197) ± 0.40 (.016)		0.60 (.024) ± 0.35 (.014)		

Benefits

- -55°C to +125°C operating temperature range
- Voltage conditioning and post-electrical testing per MIL-PRF-55681, Paragraph 4.8.3.1, Standard Voltage Conditioning
- Destructive Physical Analysis (DPA) per EIA-469
- Humidity, steady state, low voltage (85/85) per MIL-STD 202, Method 103, Condition A
- Certificate of compliance
- Pb-Free and RoHS compliant (excluding SnPb end metallization option)
- Temperature stable dielectric
- EIA 0402, 0603, 0805, 1206, 1210, 1812, and 2220 case sizes
- DC voltage ratings of 6.3V, 10V, 16V, 25V, 50V, 100V and 200V
- Capacitance offerings ranging from 150pF to 22µF
- Available capacitance tolerances of ±5%, ±10% & ±20%
- Non-polar device, minimizing installation concerns
- SnPb end metallization option available upon request (5% min)

Applications

Typical applications include military, space quality and high reliability electronics.

Qualification/Certification

Commercial grade products are subject to internal qualification. Details regarding test methods and conditions are referenced in Table 4, Performance and Reliability.

Environmental Compliance

Pb-Free and RoHS compliant (excluding SnPb termination finish option)

Electrical Parameters/Characteristics

Item	Parameters/Characteristics
Operating Temperature Range	-55°C to +125°C
Capacitance Change with Reference to +25°C and 0 Vdc Applied (TCC)	±15%
Aging Rate (Max % Cap Loss/Decade Hour)	3.0%
Dielectric Withstanding Voltage	250% of rated voltage (5 ± 1 seconds and charge/discharge not exceeding 50mA)
Dissipation Factor (DF) Maximum Limits @ 25°C	5%(10V), 3.5%(16V & 25V) and 2.5%(50V to 250V)
Insulation Resistance (IR) Limit @ 25°C	See Insulation Resistance Limit Table (Rated voltage applied for 120 ± 5 secs @ 25°C)

Regarding Aging Rate: Capacitance measurements (including tolerance) are indexed to a referee time of 1000 Hours.

To obtain IR limit, divide $M\Omega\text{-}\mu\text{F}$ value by the capacitance and compare to $G\Omega$ limit. Select the lower of the two limits.

Capacitance and Dissipation Factor (DF) measured under the following conditions:

1kHz ± 50Hz and 1.0 ± 0.2 Vrms if capacitance ≤ 10μF

120Hz ± 10Hz and 0.5 ± 0.1 Vrms if capacitance > 10μF

Note: When measuring capacitance it is important to ensure the set voltage level is held constant. The HP4284 & Agilent E4980 have a feature known as Automatic Level Control (ALC). The ALC feature should be switched to "ON".

Post Environmental Limits

High Temperature Life, Biased Humidity, Moisture Resistance					
Dielectric	Rated DC Voltage	Capacitance Value	DF (%)	Cap Shift	IR
X7R	>25	All	3.0	± 20%	10% of Initial Limit
	16 / 25		5.0		
	< 16		7.5		

Insulation Resistance Limit Table

EIA Case Size	1000 megohm microfarads or 100GΩ	500 megohm microfarads or 10GΩ
0201	N/A	ALL
0402	< .012μF	≥ .012μF
0603	< .047μF	≥ .047μF
0805	< .047μF	≥ .047μF
1206	< 0.22μF	≥ 0.22μF
1210	< 0.39μF	≥ 0.39μF
1808	ALL	N/A
1812	< 2.2μF	≥ 2.2μF
1825	ALL	N/A
2220	< 10μF	≥ 10μF
2225	ALL	N/A

Table 1A – (COTS) X7R Dielectric, (0402 - 1206 Case Sizes)

Cap	Cap Code	Series			C0402					C0603						C0805						C1206								
		Voltage Code			9	8	4	3	5	9	8	4	3	5	1	2	9	8	4	3	5	1	2	9	8	4	3	5	1	2
		Voltage DC			6.3	10	16	25	50	6.3	10	16	25	50	100	200	6.3	10	16	25	50	100	200	6.3	10	16	25	50	100	200
		Cap Tolerance			Product Availability and Chip Thickness Codes - See Table 2 for Chip Thickness Dimensions																									
150 pF	151	J	K	M	BB	BB	BB	BB	BB	CB	CB	CB	CB	CB	CB	DC	DC	DC	DC	DC	DC	DC								
180 pF	181	J	K	M	BB	BB	BB	BB	BB	CB	CB	CB	CB	CB	CB	DC	DC	DC	DC	DC	DC	DC								
220 pF	221	J	K	M	BB	BB	BB	BB	BB	CB	CB	CB	CB	CB	CB	DC	DC	DC	DC	DC	DC	DC								
270 pF	271	J	K	M	BB	BB	BB	BB	BB	CB	CB	CB	CB	CB	CB	DC	DC	DC	DC	DC	DC	DC								
330 pF	331	J	K	M	BB	BB	BB	BB	BB	CB	CB	CB	CB	CB	CB	DC	DC	DC	DC	DC	DC	DC								
390 pF	391	J	K	M	BB	BB	BB	BB	BB	CB	CB	CB	CB	CB	CB	DC	DC	DC	DC	DC	DC	DC								
470 pF	471	J	K	M	BB	BB	BB	BB	BB	CB	CB	CB	CB	CB	CB	DC	DC	DC	DC	DC	DC	DC								
560 pF	561	J	K	M	BB	BB	BB	BB	BB	CB	CB	CB	CB	CB	CB	DC	DC	DC	DC	DC	DC	DC								
680 pF	681	J	K	M	BB	BB	BB	BB	BB	CB	CB	CB	CB	CB	CB	DC	DC	DC	DC	DC	DC	DC								
820 pF	821	J	K	M	BB	BB	BB	BB	BB	CB	CB	CB	CB	CB	CB	DC	DC	DC	DC	DC	DC	DC								
1,000 pF	102	J	K	M	BB	BB	BB	BB	BB	CB	CB	CB	CB	CB	CB	DC	DC	DC	DC	DC	DC	DC	EB	EB	EB	EB	EB	EB	EB	
1,200 pF	122	J	K	M	BB	BB	BB	BB	BB	CB	CB	CB	CB	CB	CB	DC	DC	DC	DC	DC	DC	DC	EB	EB	EB	EB	EB	EB	EB	
1,500 pF	152	J	K	M	BB	BB	BB	BB	BB	CB	CB	CB	CB	CB	CB	DC	DC	DC	DC	DC	DC	DC	EB	EB	EB	EB	EB	EB	EB	
1,800 pF	182	J	K	M	BB	BB	BB	BB	BB	CB	CB	CB	CB	CB	CB	DC	DC	DC	DC	DC	DC	DC	EB	EB	EB	EB	EB	EB	EB	
2,200 pF	222	J	K	M	BB	BB	BB	BB	BB	CB	CB	CB	CB	CB	CB	DC	DC	DC	DC	DC	DC	DC	EB	EB	EB	EB	EB	EB	EB	
2,700 pF	272	J	K	M	BB	BB	BB	BB	BB	CB	CB	CB	CB	CB	CB	DC	DC	DC	DC	DC	DC	DC	EB	EB	EB	EB	EB	EB	EB	
3,300 pF	332	J	K	M	BB	BB	BB	BB	BB	CB	CB	CB	CB	CB	CB	DC	DC	DC	DC	DC	DC	DC	EB	EB	EB	EB	EB	EB	EB	
3,900 pF	392	J	K	M	BB	BB	BB	BB	BB	CB	CB	CB	CB	CB	CB	DC	DC	DC	DC	DC	DC	DC	EB	EB	EB	EB	EB	EB	EB	
4,700 pF	472	J	K	M	BB	BB	BB	BB	BB	CB	CB	CB	CB	CB	CB	DC	DC	DC	DC	DC	DC	DC	EB	EB	EB	EB	EB	EB	EB	
5,600 pF	562	J	K	M	BB	BB	BB	BB	BB	CB	CB	CB	CB	CB	CB	DC	DC	DC	DC	DC	DC	DC	EB	EB	EB	EB	EB	EB	EB	
6,800 pF	682	J	K	M	BB	BB	BB	BB	BB	CB	CB	CB	CB	CB	CB	DC	DC	DC	DC	DC	DC	DC	EB	EB	EB	EB	EB	EB	EB	
8,200 pF	822	J	K	M	BB	BB	BB	BB	BB	CB	CB	CB	CB	CB	CB	DC	DC	DC	DC	DC	DC	DC	EB	EB	EB	EB	EB	EB	EB	
10,000 pF	103	J	K	M	BB	BB	BB	BB	BB	CB	CB	CB	CB	CB	CB	DC	DC	DC	DC	DC	DC	DC	EB	EB	EB	EB	EB	EB	EB	
12,000 pF	123	J	K	M	BB	BB	BB	BB	BB	CB	CB	CB	CB	CB	CB	DC	DC	DC	DC	DC	DC	DC	EB	EB	EB	EB	EB	EB	EB	
15,000 pF	153	J	K	M	BB	BB	BB	BB	BB	CB	CB	CB	CB	CB	CB	DC	DC	DC	DC	DC	DC	DC	EB	EB	EB	EB	EB	EB	EB	
18,000 pF	183	J	K	M	BB	BB	BB	BB	BB	CB	CB	CB	CB	CB	CB	DC	DC	DC	DC	DC	DC	DD	EB	EB	EB	EB	EB	EB	EB	
22,000 pF	223	J	K	M	BB	BB	BB	BB	BB	CB	CB	CB	CB	CB	CB	DC	DC	DC	DC	DC	DC	DD	EB	EB	EB	EB	EB	EB	EB	
27,000 pF	273	J	K	M	BB	BB	BB	BB	BB	CB	CB	CB	CB	CB	CB	DC	DC	DC	DC	DC	DC	DD	DE	EB	EB	EB	EB	EB	EB	
33,000 pF	333	J	K	M	BB	BB	BB	BB	BB	CB	CB	CB	CB	CB	CB	DC	DC	DC	DC	DC	DC	DD	DE	EB	EB	EB	EB	EB	EB	
39,000 pF	393	J	K	M	BB	BB	BB	BB	BB	CB	CB	CB	CB	CB	CB	DC	DC	DC	DC	DC	DC	DD	DE	EB	EB	EB	EB	EB	EB	
47,000 pF	473	J	K	M	BB	BB	BB	BB	BB	CB	CB	CB	CB	CB	CB	DC	DC	DC	DC	DC	DC	DE	DG	EB	EB	EB	EB	EB	EB	
56,000 pF	563	J	K	M	BB	BB	BB	BB	BB	CB	CB	CB	CB	CB	CB	DD	DD	DD	DD	DD	DD	DE	DG	EB	EB	EB	EB	EB	EB	
68,000 pF	683	J	K	M	BB	BB	BB	BB	BB	CB	CB	CB	CB	CB	CB	DD	DD	DD	DD	DD	DD	DE	DG	EB	EB	EB	EB	EB	EB	
82,000 pF	823	J	K	M	BB	BB	BB	BB	BB	CB	CB	CB	CB	CB	CB	DD	DD	DD	DD	DD	DD	DE	DG	EB	EB	EB	EB	EB	EB	
0.10 µF	104	J	K	M	BB	BB	BB	BB	BB	CB	CB	CB	CB	CB	CB	DD	DD	DD	DD	DD	DD	DE	DG	EB	EB	EB	EB	EB	EB	
0.12 µF	124	J	K	M						CB	CB	CB	CB			DC	DC	DC	DC	DC	DD	DG	EC	EC	EC	EC	EC	EC	EC	
0.15 µF	154	J	K	M						CB	CB	CB	CB			DC	DC	DC	DC	DC	DD	DG	EC	EC	EC	EC	EC	EC	EC	
0.18 µF	184	J	K	M						CB	CB	CB	CB			DC	DC	DC	DC	DC	DD	DG	EC	EC	EC	EC	EC	EC	EC	
0.22 µF	224	J	K	M						CB	CB	CB	CD			DC	DC	DC	DC	DC	DD	DG	EC	EC	EC	EC	EC	EC	EC	
0.27 µF	274	J	K	M						CB	CB	CB				DD	DD	DD	DD	DD	DD	DG	EB	EB	EB	EB	EB	EB	EB	
0.33 µF	334	J	K	M						CB	CB	CB				DD	DD	DD	DD	DD	DD	DG	EB	EB	EB	EB	EB	EB	EB	
0.39 µF	394	J	K	M						CB	CB	CB				DG	DG	DG	DG	DG	DE	DG	EB	EB	EB	EB	EB	EB	EB	
0.47 µF	474	J	K	M						CB	CB	CB				DD	DD	DD	DD	DE	DE	DG	EB	EB	EB	EB	EB	EB	EB	
0.56 µF	564	J	K	M												DD	DD	DD	DG	DH	DH	DG	ED	ED	ED	ED	ED	ED	ED	
0.68 µF	684	J	K	M												DD	DD	DD	DG	DH	DH	DG	EE	EE	EE	EE	EE	EE	EE	
0.82 µF	824	J	K	M												DD	DD	DD	DG				EF	EF	EF	EF	ED			
1.0 µF	105	J	K	M												DD	DD	DD	DG				EF	EF	EF	EG	ED			
1.2 µF	125	J	K	M												DE	DE	DE					ED	ED	ED	EG	EH			
1.5 µF	155	J	K	M												DG	DG	DG					EF	EF	EF	EG	EH			
1.8 µF	185	J	K	M												DG	DG	DG					EF	EF	EF	EG	EH			
2.2 µF	225	J	K	M												DG	DG	DG					ED	ED	ED	EF	EH			
2.7 µF	275	J	K	M																			EN	EN	EN	EH				
3.3 µF	335	J	K	M																			ED	ED	ED	EH				
Cap	Cap Code	Series			C0402					C0603						C0805						C1206								
		Voltage DC			6.3	10	16	25	50	6.3	10	16	25	50	100	200	6.3	10	16	25	50	100	200	6.3	10	16	25	50	100	200
		Voltage Code			9	8	4	3	5	9	8	4	3	5	1	2	9	8	4	3	5	1	2	9	8	4	3	5	1	2

Table 1A – (COTS) X7R Dielectric, (0402 - 1206 Case Sizes) con't

Cap	Cap Code	Series	C0402					C0603						C0805						C1206																			
		Voltage Code	9	8	4	3	5	9	8	4	3	5	1	2	9	8	4	3	5	1	2	9	8	4	3	5	1	2											
		Voltage DC	6.3	10	16	25	50	6.3	10	16	25	50	100	200	6.3	10	16	25	50	100	200	6.3	10	16	25	50	100	200											
		Cap Tolerance	Product Availability and Chip Thickness Codes - See Table 2 for Chip Thickness Dimensions																																				
3.9 µF	395	J	K	M																							EF	EF	EF	EH									
4.7 µF	475	J	K	M																								EF	EF	EF	EH								
5.6 µF	565	J	K	M																								EH	EH	EH									
6.8 µF	685	J	K	M																								EH	EH	EH									
8.2 µF	825	J	K	M																								EH	EH	EH									
10 µF	106	J	K	M																								EH	EH	EH									
12 µF	126	J	K	M																								EH	EH	EH									
Cap	Cap Code	Voltage DC	6.3	10	16	25	50	6.3	10	16	25	50	100	200	6.3	10	16	25	50	100	200	6.3	10	16	25	50	100	200											
		Voltage Code	9	8	4	3	5	9	8	4	3	5	1	2	9	8	4	3	5	1	2	9	8	4	3	5	1	2											
		Series	C0402					C0603						C0805						C1206																			

Table 1B – (1210 - 2220 Case Sizes)

Cap	Cap Code	Series	C1210							C1812					C2220																								
		Voltage Code	9	8	4	3	5	1	2	3	5	1	2	A	3	5	1	2																					
		Voltage DC	6.3	10	16	25	50	100	200	25	50	100	200	250	25	50	100	200																					
		Cap Tolerance	Product Availability and Chip Thickness Codes - See Table 2 for Chip Thickness Dimensions																																				
2,200 pF	222	J	K	M	FB	FB	FB	FB	FB	FB																													
2,700 pF	272	J	K	M	FB	FB	FB	FB	FB	FB																													
3,300 pF	332	J	K	M	FB	FB	FB	FB	FB	FB																													
3,900 pF	392	J	K	M	FB	FB	FB	FB	FB	FB																													
4,700 pF	472	J	K	M	FB	FB	FB	FB	FB	FB																													
5,600 pF	562	J	K	M	FB	FB	FB	FB	FB	FB																													
6,800 pF	682	J	K	M	FB	FB	FB	FB	FB	FB												GB	GB	GB															
8,200 pF	822	J	K	M	FB	FB	FB	FB	FB	FB												GB	GB	GB															
10,000 pF	103	J	K	M	FB	FB	FB	FB	FB	FB												GB	GB	GB															
12,000 pF	123	J	K	M	FB	FB	FB	FB	FB	FB												GB	GB	GB															
15,000 pF	153	J	K	M	FB	FB	FB	FB	FB	FB												GB	GB	GB															
18,000 pF	183	J	K	M	FB	FB	FB	FB	FB	FB												GB	GB	GB															
22,000 pF	223	J	K	M	FB	FB	FB	FB	FB	FB												GB	GB	GB															
27,000 pF	273	J	K	M	FB	FB	FB	FB	FB	FB												GB	GB	GB															
33,000 pF	333	J	K	M	FB	FB	FB	FB	FB	FB												GB	GB	GB															
39,000 pF	393	J	K	M	FB	FB	FB	FB	FB	FB												GB	GB	GB															
47,000 pF	473	J	K	M	FB	FB	FB	FB	FB	FB												GB	GB	GB															
56,000 pF	563	J	K	M	FB	FB	FB	FB	FB	FB												GB	GB	GB															
68,000 pF	683	J	K	M	FB	FB	FB	FB	FB	FB												GB	GB	GB															
82,000 pF	823	J	K	M	FB	FB	FB	FB	FB	FC												GB	GB	GB															
0.10 µF	104	J	K	M	FB	FB	FB	FB	FB	FD												GB	GB	GB															
0.12 µF	124	J	K	M	FB	FB	FB	FB	FB	FD												GB	GB	GB															
0.15 µF	154	J	K	M	FC	FC	FC	FC	FC	FD												GB	GB	GB															
0.18 µF	184	J	K	M	FC	FC	FC	FC	FC	FD												GB	GB	GB															
0.22 µF	224	J	K	M	FC	FC	FC	FC	FC	FD												GB	GB	GB															
0.27 µF	274	J	K	M	FC	FC	FC	FC	FC	FD												GB	GB	GG				JC	JC	JC	JC	JC	JC	JC	JC	JC	JC		
0.33 µF	334	J	K	M	FD	FD	FD	FD	FD	FD												GB	GB	GG				JC	JC	JC	JC	JC	JC	JC	JC	JC	JC		
0.39 µF	394	J	K	M	FD	FD	FD	FD	FD	FD												GB	GB	GG				JC	JC	JC	JC	JC	JC	JC	JC	JC	JC		
0.47 µF	474	J	K	M	FD	FD	FD	FD	FD	FD												GB	GB	GG				JC	JC	JC	JC	JC	JC	JC	JC	JC	JC		
0.56 µF	564	J	K	M	FD	FD	FD	FD	FD	FF												GC	GC	GG				JC	JC	JC	JC	JC	JC	JC	JC	JC	JC		
Cap	Cap Code	Voltage DC	6.3	10	16	25	50	100	200	25	50	100	200	250	25	50	100	200																					
		Voltage Code	9	8	4	3	5	1	2	3	5	1	2	A	3	5	1	2																					
		Series	C1210							C1812					C2220																								

Table 1B – (COTS) X7R Dielectric, (1210 - 2220 Case Sizes) con't

Cap	Cap Code	Series			C1210						C1812					C2220				
		Voltage Code			9	8	4	3	5	1	2	3	5	1	2	A	3	5	1	2
		Voltage DC			6.3	10	16	25	50	100	200	25	50	100	200	250	25	50	100	200
		Cap Tolerance			Product Availability and Chip Thickness Codes - See Table 2 for Chip Thickness Dimensions															
0.68 µF	684	J	K	M	FD	FD	FD	FD	FD	FG		GC	GC	GG		JC	JC			
0.82 µF	824	J	K	M	FF	FF	FF	FF	FF	FL		GE	GE	GG		JC	JC			
1.0 µF	105	J	K	M	FH	FH	FH	FH	FH	FM		GE	GE	GG		JC	JC			
1.2 µF	125	J	K	M	FH	FH	FH	FH	FH	FG						JC	JC			
1.5 µF	155	J	K	M	FH	FH	FH	FH	FH	FG						JC	JC			
1.8 µF	185	J	K	M	FH	FH	FH	FH	FG						JD	JD				
2.2 µF	225	J	K	M	FJ	FJ	FJ	FJ	FG			GO	GO		JF	JF				
2.7 µF	275	J	K	M	FE	FE	FE	FG	FH											
3.3 µF	335	J	K	M	FF	FF	FF	FM	FM											
3.9 µF	395	J	K	M	FG	FG	FG	FG	FK											
4.7 µF	475	J	K	M	FC	FC	FC	FG	FS			GK	GK							
5.6 µF	565	J	K	M	FF	FF	FF	FH												
6.8 µF	685	J	K	M	FG	FG	FG	FM												
8.2 µF	825	J	K	M	FH	FH	FH	FK												
10 µF	106	J	K	M	FH	FH	FH	FS				GK			JF	JO				
12 µF	126	J	K	M																
15 µF	156	J	K	M																
18 µF	186	J	K	M																
22 µF	226	J	K	M	FS	FS														
47 µF	476	J	K	M																
Cap	Cap Code	Voltage DC			6.3	10	16	25	50	100	200	25	50	100	200	250	25	50	100	200
		Voltage Code			9	8	4	3	5	1	2	3	5	1	2	A	3	5	1	2
		Series			C1210						C1812					C2220				

High Temperature 150°C, Ultra-Stable X8R Dielectric, 25VDC-100VDC (Commercial & Automotive Grade)

Overview

KEMET's Ultra-Stable X8R dielectric features a 150°C maximum operating temperature, offering the latest in high temperature dielectric technology and reliability for extreme temperature applications. It offers the same temperature capability as conventional X8R, but without the capacitance loss due to applied DC voltage. Ultra-Stable X8R exhibits no change in capacitance with respect to voltage and boasts a minimal change in capacitance with reference to ambient temperature. It is a suitable replacement for higher capacitance and larger footprint devices that fail to offer capacitance stability. Capacitance change with respect to temperature is limited to $\pm 15\%$ from -55°C to +150°C.

Driven by the demand for a more robust and reliable component, Ultra-Stable X8R dielectric capacitors were developed for critical applications where reliability and capacitance stability at higher operating temperatures are a concern. These capacitors are manufactured in state of the art ISO/TS 16949:2002 certified facilities and are widely used in automotive circuits as well as general high temperature applications.

In addition to commercial grade, automotive grade devices are available and meet the demanding Automotive Electronics Council's AEC-Q200 qualification requirements.

Benefits

- -55°C to +150°C operating temperature range
- Pb-Free and RoHS compliant
- EIA 0402, 0603, 0805, 1206, 1210 and 1812 case sizes
- DC voltage ratings of 25V, 50V and 100V
- Capacitance offerings ranging from 10pF to 0.22 μ F
- Available capacitance tolerances of $\pm 1\%$, $\pm 2\%$, $\pm 5\%$, $\pm 10\%$ and $\pm 20\%$,
- Extremely low ESR and ESL
- High thermal stability
- High ripple current capability
- No capacitance change with respect to applied rated DC voltage
- Non-polar device, minimizing installation concerns
- Offered in both commercial and automotive grades
- 100% pure matte tin-plated termination finish that allowing for excellent solderability.
- SnPb plated termination finish option available upon request (5% min)

Applications

Typical applications include decoupling, bypass and filtering in extreme environments such as down-hole oil exploration, under-hood automotive, military and aerospace.

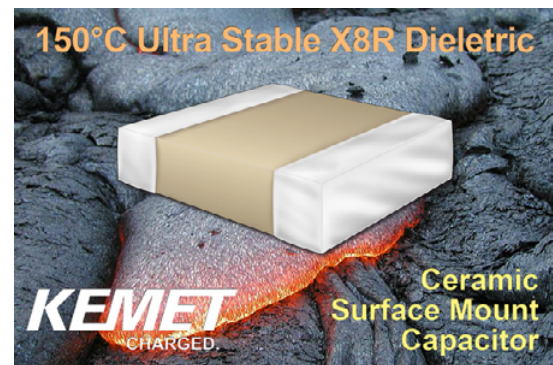

Ordering Information

C	1210	C	184	K	3	H	A	C	AUTO
Ceramic	Case Size (L" x W")	Specification/ Series	Capacitance Code (pF)	Capacitance Tolerance	Voltage	Dielectric	Failure Rate/ Design	Termination Finish ¹	Packaging/Grade (C-Spec) ²
	0402 0603 0805 1206 1210 1812	C = Standard	2 Sig. Digits + Number of Zeros	F = $\pm 1\%$ G = $\pm 2\%$ J = $\pm 5\%$ K = $\pm 10\%$ M = $\pm 20\%$	3 = 25V 5 = 50V 1 = 100V	H = Ultra Stable X8R	A = N/A	C = 100% Matte Sn L = SnPb (5% min)	Blank = Bulk TU = 7" Reel Unmarked AUTO = Automotive Grade 7" Reel Unmarked

¹ Additional termination finish options may be available. Contact KEMET for details.

² Additional reeling or packaging options may be available. Contact KEMET for details.

Dimensions – Millimeters (Inches)

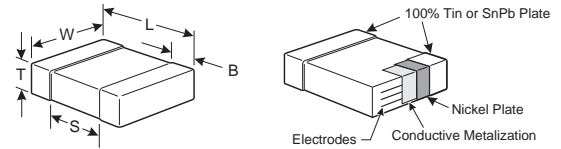

EIA Size Code	Metric Size Code	L Length	W Width	T Thickness	B Bandwidth	S Separation Min.	Mounting Technique
0402	1005	1.00 (.040) ± 0.05 (.002)	0.50 (.020) ± 0.05 (.002)	See Table 2 for Thickness	0.30 (.012) ± 0.10 (.004)	0.30 (.012)	Solder Reflow Only
0603	1608	1.60 (.063) ± 0.15 (.006)	0.80 (.032) ± 0.15 (.006)		0.35 (.014) ± 0.15 (.006)	0.70 (.028)	Solder Wave or Solder Reflow
0805	2012	2.00 (.079) ± 0.20 (.008)	1.25 (.049) ± 0.20 (.008)		0.50 (0.02) ± 0.25 (.010)	0.75 (.030)	
1206	3216	3.20 (.126) ± 0.20 (.008)	1.60 (.063) ± 0.20 (.008)		0.50 (0.02) ± 0.25 (.010)	N/A	Solder Reflow Only
1210	3225	3.20 (.126) ± 0.20 (.008)	2.50 (.098) ± 0.20 (.008)		0.50 (0.02) ± 0.25 (.010)		
1812	4532	4.50 (.177) ± 0.30 (.012)	3.20 (.126) ± 0.30 (.012)		0.60 (.024) ± 0.35 (.014)		

Qualification/Certification

Commercial grade products are subject to internal qualification. Details regarding test methods and conditions are referenced in Table 4, Performance and Reliability.

Automotive grade products meet or exceed the requirements outlined by the Automotive Electronics Council. Details regarding test methods and conditions are referenced in document AEC-Q200, Stress Test Qualification for Passive Components. For additional information regarding the Automotive Electronics Council and AEC-Q200, please visit their website @www.aecouncil.com.

Environmental Compliance

Pb-Free and RoHS compliant (excluding SnPb termination finish option)

Electrical Parameters/Characteristics

Item	Parameters/Characteristics
Operating Temperature Range	-55°C to +150°C
Capacitance Change with Reference to +25°C and 0 Vdc Applied (TCC)	±15%
Aging Rate (Max % Cap Loss/Decade Hour)	0%
Dielectric Withstanding Voltage	250% of rated voltage (5 ± 1 seconds and charge/discharge not exceeding 50mA)
Dissipation Factor (DF) Maximum Limits @ 25°C	2.5%
Insulation Resistance (IR) Limit @ 25°C	1000 megohm microfarads or 100GΩ (Rated voltage applied for 120 ± 5 secs @ 25°C)

To obtain IR limit, divide $M\Omega\text{-}\mu F$ value by the capacitance and compare to $G\Omega$ limit. Select the lower of the two limits.

Capacitance and Dissipation Factor (DF) measured under the following conditions:

1MHz ± 100kHz and 1.0 ± 0.2 Vrms if capacitance ≤ 1000pF.

1kHz ± 50Hz and 1.0 ± 0.2 Vrms if capacitance > 1000pF

Note: When measuring capacitance it is important to ensure the set voltage level is held constant. The HP4284 & Agilent E4980 have a feature known as Automatic Level Control (ALC). The ALC feature should be switched to "ON".

Post Environmental Limits

High Temperature Life, Biased Humidity, Moisture Resistance					
Dielectric	Rated DC Voltage	Capacitance Value	DF (%)	Cap Shift	IR
Ultra Stable X8R	All	All	2.5	0.3% or ± 0.25 pf	10% of Initial Limit

Table 1 – X8R Dielectric, (0402 - 1812 Case Sizes)

Cap	Cap Code	Series					C0402			C0603			C0805			C1206			C1210			C1812	
		Voltage Code					3	5	1	3	5	1	3	5	1	3	5	1	3	5	1	5	1
		Voltage DC					25	50	100	25	50	100	25	50	100	25	50	100	25	50	100	50	100
		Cap Tolerance					Product Availability and Chip Thickness Codes See Table 2 for Chip Thickness Dimensions																
100 pF	101	F	G	J	K	M	BB	BB	BB														
110 pF	111	F	G	J	K	M	BB	BB	BB														
120 pF	121	F	G	J	K	M	BB	BB	BB														
130 pF	131	F	G	J	K	M	BB	BB	BB														
150 pF	151	F	G	J	K	M	BB	BB	BB														
160 pF	161	F	G	J	K	M	BB	BB	BB														
180 pF	181	F	G	J	K	M	BB	BB	BB														
200 pF	201	F	G	J	K	M	BB	BB	BB														
220 pF	221	F	G	J	K	M	BB	BB	BB														
240 pF	241	F	G	J	K	M	BB	BB	BB														
270 pF	271	F	G	J	K	M	BB	BB	BB														
300 pF	301	F	G	J	K	M	BB	BB	BB														
330 pF	331	F	G	J	K	M	BB	BB	BB														
360 pF	361	F	G	J	K	M	BB	BB	BB														
390 pF	391	F	G	J	K	M	BB	BB	BB														
430 pF	431	F	G	J	K	M	BB	BB	BB	CB	CB	CB											
470 pF	471	F	G	J	K	M	BB	BB	BB	CB	CB	CB											
510 pF	511	F	G	J	K	M	BB	BB	BB	CB	CB	CB											
560 pF	561	F	G	J	K	M	BB	BB	BB	CB	CB	CB											
620 pF	621	F	G	J	K	M	BB	BB	BB	CB	CB	CB											
680 pF	681	F	G	J	K	M	BB	BB	BB	CB	CB	CB											
750 pF	751	F	G	J	K	M	BB	BB	BB	CB	CB	CB											
820 pF	821	F	G	J	K	M	BB	BB	BB	CB	CB	CB											
910 pF	911	F	G	J	K	M	BB	BB	BB	CB	CB	CB											
1,000 pF	102	F	G	J	K	M	BB	BB	BB	CB	CB	CB											
1,100 pF	112	F	G	J	K	M	BB	BB		CB	CB	CB											
1,200 pF	122	F	G	J	K	M	BB	BB		CB	CB	CB											
1,300 pF	132	F	G	J	K	M	BB	BB		CB	CB	CB											
1,500 pF	152	F	G	J	K	M	BB	BB		CB	CB	CB											
1,600 pF	162	F	G	J	K	M				CB	CB	CB											
1,800 pF	182	F	G	J	K	M				CB	CB	CB											
2,000 pF	202	F	G	J	K	M				CB	CB	CB											
2,200 pF	222	F	G	J	K	M				CB	CB	CB	DC	DC	DC								
2,400 pF	242	F	G	J	K	M				CB	CB	CB	DC	DC	DC	DC							
2,700 pF	272	F	G	J	K	M				CB	CB	CB	DC	DC	DC								
3,000 pF	302	F	G	J	K	M				CB	CB	CB	DC	DC	DC								
3,300 pF	332	F	G	J	K	M				CB	CB	CB	DC	DC	DC								
3,600 pF	362	F	G	J	K	M				CB	CB	CB	DC	DC	DC								
3,900 pF	392	F	G	J	K	M				CB	CB	CB	DC	DC	DC								
4,300 pF	432	F	G	J	K	M				CB	CB	CB	DC	DC	DC								
4,700 pF	472	F	G	J	K	M				CB	CB	CB	DC	DC	DC								
5,100 pF	512	F	G	J	K	M				CB	CB		DC	DC	DC								
5,600 pF	562	F	G	J	K	M				CB	CB		DC	DC	DC								
6,200 pF	622	F	G	J	K	M				CB	CB		DC	DC	DC								
6,800 pF	682	F	G	J	K	M				CB	CB		DC	DC	DC	EB	EB	EB					
7,500 pF	752	F	G	J	K	M				CB			DC	DC	DC	EB	EB	EB					
8,200 pF	822	F	G	J	K	M				CB			DC	DC	DC	EB	EB	EB					
9,100 pF	912	F	G	J	K	M				CB			DC	DC	DC	EB	EB	EB					
10,000 pF	103	F	G	J	K	M				CB			DC	DC	DD	EB	EB	EB					
12,000 pF	123	F	G	J	K	M							DC	DC	DE	EB	EB	EB	FB	FB	FB		
15,000 pF	153	F	G	J	K	M							DC	DD	DG	EB	EB	EB	FB	FB	FB	GB	GB
18,000 pF	183	F	G	J	K	M							DC	DD		EB	EB	EB	FB	FB	FB	GB	GB
22,000 pF	223	F	G	J	K	M							DD	DF		EB	EB	EC	FB	FB	FB	GB	GB
27,000 pF	273	F	G	J	K	M							DF			EB	EB	EE	FB	FB	FB	GB	GB
33,000 pF	333	F	G	J	K	M							DG			EB	EB	EE	FB	FB	FB	GB	GB
47,000 pF	473	F	G	J	K	M										EC	EE	EH	FB	FB	FE	GB	GB
56,000 pF	563	F	G	J	K	M										ED	EF	EH	FB	FB	FF	GB	GB
Cap	Cap Code	Voltage DC					25	50	100	25	50	100	25	50	100	25	50	100	25	50	100	50	100
		Voltage Code					3	5	1	3	5	1	3	5	1	3	5	1	3	5	1	5	1
		Series					C0402			C0603			C0805			C1206			C1210			C1812	

Table 1 – X8R Dielectric, (0402 - 1812 Case Sizes) con't

Cap	Cap Code	Series					C0402			C0603			C0805			C1206			C1210			C1812						
		Voltage Code	3	5	1		3	5	1	3	5	1	3	5	1	3	5	1	3	5	1	5	1					
Voltage DC		25	50	100		25	50	100	25	50	100	25	50	100	25	50	100	25	50	100	50	100						
Cap Tolerance		Product Availability and Chip Thickness Codes See Table 2 for Chip Thickness Dimensions																										
68,000 pF	683	F	G	J	K	M									EF	EH		FB	FC	FG	GB	GB						
82,000 pF	823	F	G	J	K	M									EH	EH		FC	FF	FH	GB	GB						
100,000 pF	104	F	G	J	K	M									EH			FE	FG	FM	GB	GD						
120,000 pF	124	F	G	J	K	M												FG	FH		GB	GH						
150,000 pF	154	F	G	J	K	M												FH	FM		GD	GN						
180,000 pF	184	F	G	J	K	M												FJ			GH							
220,000 pF	224	F	G	J	K	M															GK							
Cap	Cap Code	Voltage DC					25			50			100			25			50			100			50		100	
		Voltage Code	3	5	1		3	5	1	3	5	1	3	5	1	3	5	1	3	5	1	3	5	1	5	1		
Series		C0402					C0603			C0805			C1206			C1210			C1812									

High Temperature 150°C, X8L Dielectric, 10VDC-50VDC (Commercial & Automotive Grade)

Overview

KEMET's X8L dielectric features a 150°C maximum operating temperature and is considered "general purpose high temperature." These components are fixed, ceramic dielectric capacitors suited for high temperature bypass and decoupling applications or frequency discriminating circuits where Q and stability of capacitance characteristics are not critical. X8L exhibits a predictable change in capacitance with respect to time and voltage and boasts a minimal change in capacitance with reference to ambient temperature up to 125°C. Beyond 125°C X8L displays a wider variation in capacitance. Capacitance change is limited to ±15% from -55°C to +125°C and +15, -40% from 125°C to 150°C.

Driven by the demand for a more robust and reliable component, X8L dielectric capacitors were developed for critical applications where reliability at higher operating temperatures are a concern. These capacitors are manufactured in state of the art ISO/TS

16949:2002 certified facilities and are widely used in automotive circuits as well as general high temperature applications.

Concerned with flex cracks resulting from excessive shear stresses produced during board flexure or thermal cycling? These devices are available with KEMET's Flexible termination technology which directs board flex stress away from the ceramic body and into the termination area, therefore mitigating flex cracks which can result in low IR or short circuit failures. Although flexible termination technology does not eliminate the potential for mechanical damage that may propagate during extreme environmental and handling conditions, it does provide superior flex performance over standard termination systems.

In addition to commercial grade, automotive grade devices are available and meet the demanding Automotive Electronics Council's AEC-Q200 qualification requirements.

Benefits

- -55°C to +150°C operating temperature range
- Pb-Free & RoHS compliant
- EIA 0402, 0603, 0805, 1206 & 1210 case sizes
- DC voltage ratings of 10V, 25V & 50V
- Capacitance offerings ranging from .012µF to 10µF
- Available capacitance tolerances of ±5%, ±10% & ±20%
- Commercial & Automotive (AEC-Q200) grades available
- Non-polar device, minimizing installation concerns

- 100% pure matte tin-plated termination finish allowing for excellent solderability
- SnPb termination finish option available upon request (5% min)
- Flexible termination option available upon request

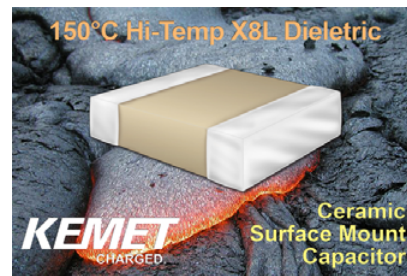

Ordering Information

C	1210	X	106	K	8	N	A	C	TU
Ceramic	Case Size (L" x W")	Specification/ Series ¹	Capacitance Code (pF)	Capacitance Tolerance	Voltage	Dielectric	Failure Rate/ Design	Termination Finish ²	Packaging/Grade (C-Spec) ³
	0402 0603 0805 1206 1210	C = Standard X = Flexible Termination	2 Sig. Digits + Number of Zeros	J = ±5% K = ±10% M = ±20%	8 = 10V 3 = 25V 5 = 50V	N = X8L	A = N/A	C = 100% Matte Sn L = SnPb (5% min)	Blank = Bulk TU = 7" Reel Unmarked TM = 7" Reel Marked AUTO = Automotive Grade 7" Reel Unmarked

¹ The flexible termination option is not available on EIA 0402 case size product. "C" must be used in the 6th character position when ordering this case size.

² Additional termination finish options may be available. Contact KEMET for details.

^{2,3} SnPb termination finish option is not available on automotive grade product.

³ Additional reeling or packaging options may be available. Contact KEMET for details.

Dimensions – Standard Termination – Millimeters (Inches)

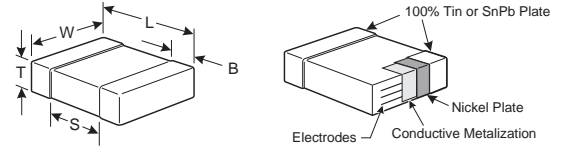

EIA Size Code	Metric Size Code	L Length	W Width	T Thickness	B Bandwidth	S Separation Min.	Mounting Technique
0402	1005	1.00 (.040) ± 0.05 (.002)	0.50 (.020) ± 0.05 (.002)	See Table 2 for Thickness	0.30 (.012) ± 0.10 (.004)	0.30 (.012)	Solder Reflow Only
0603	1608	1.60 (.063) ± 0.15 (.006)	0.80 (.032) ± 0.15 (.006)		0.35 (.014) ± 0.15 (.006)	0.70 (.028)	Solder Wave or Solder Reflow
0805	2012	2.00 (.079) ± 0.20 (.008)	1.25 (.049) ± 0.20 (.008)		0.50 (0.02) ± 0.25 (.010)	0.75 (.030)	
1206	3216	3.20 (.126) ± 0.20 (.008)	1.60 (.063) ± 0.20 (.008)		0.50 (0.02) ± 0.25 (.010)	N/A	Solder Reflow Only
1210	3225	3.20 (.126) ± 0.20 (.008)	2.50 (.098) ± 0.20 (.008)		0.50 (0.02) ± 0.25 (.010)		

Dimensions – Flexible Termination – Millimeters (Inches)

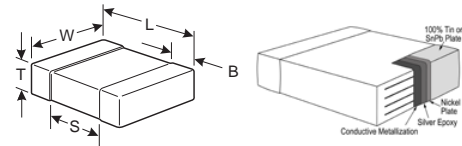

EIA Size Code	Metric Size Code	L Length	W Width	T Thickness	B Bandwidth	S Separation Min.	Mounting Technique
0603	1608	1.60 (.063) +0.20 (.008)/-0.10 (.004)	0.80 (.032) ± 0.15 (.006)	See Table 2 for Thickness	0.45 (.018) +0.05 (.002)/-0.15 (.006)	0.50 (.020)	Solder Wave or Solder Reflow
0805	2012	2.10 (.083) +0.30 (.012)/-0.20 (.008)	1.25 (.049) ± 0.20 (.008)		0.50 (0.02) +0.10 (.004)/-0.25 (.010)	0.70 (.028)	
1206	3216	3.30 (.130) ± 0.40 (.016)	1.60 (.063) ± 0.20 (.008)		0.60 (.024) ± 0.25 (.010)	N/A	Solder Reflow Only
1210	3225	3.30 (.130) ± 0.40 (.016)	2.50 (.098) ± 0.20 (.008)		0.60 (.024) ± 0.25 (.010)		

Applications

Typical applications include use in extreme environments such as down-hole oil exploration, under-hood automotive, military and aerospace.

Qualification/Certification

Commercial grade products are subject to internal qualification. Details regarding test methods and conditions are referenced in Table 4, Performance and Reliability.

Automotive grade products meet or exceed the requirements outlined by the Automotive Electronics Council. Details regarding test methods and conditions are referenced in document AEC-Q200, Stress Test Qualification for Passive Components. For additional information regarding the Automotive Electronics Council and AEC-Q200, please visit their website at www.aecouncil.com.

Environmental Compliance

Pb-Free and RoHS compliant (excluding SnPb termination finish option).

Electrical Parameters/Characteristics

Item	Parameters/Characteristics
Operating Temperature Range	-55°C to +150°C
Capacitance Change with Reference to +25°C and 0 Vdc Applied (TCC)	±15% (-55°C–125°C) +15, -40% (125°C–150°C)
Aging Rate (Max % Cap Loss/Decade Hour)	3.0%
Dielectric Withstanding Voltage	250% of rated voltage (5 ± 1 seconds and charge/discharge not exceeding 50mA)
Dissipation Factor (DF) Maximum Limits @ 25°C	3.5% (10V) and 2.5% (25V & 50V)
Insulation Resistance (IR) Limit @ 25°C	500 megohm microfarads or 10GΩ (Rated voltage applied for 120 ± 5 secs @ 25°C)

Regarding Aging Rate: Capacitance measurements (including tolerance) are indexed to a referee time of 1000 hours.

To obtain IR limit, divide $M\Omega\text{-}\mu F$ value by the capacitance and compare to $G\Omega$ limit. Select the lower of the two limits.

Capacitance and Dissipation Factor (DF) measured under the following conditions:

1kHz ± 50Hz and 1.0 ± 0.2 Vrms.

Note: When measuring capacitance it is important to ensure the set voltage level is held constant. The HP4284 & Agilent E4980 have a feature known as Automatic Level Control (ALC). The ALC feature should be switched to "ON."

Post Environmental Limits

High Temperature Life, Biased Humidity, Moisture Resistance					
Dielectric	Rated DC Voltage	Capacitance Value	DF (%)	Cap Shift	IR
X8L	>25	All	3.0	± 20%	10% of Initial Limit
	25		5.0		
	10		7.5		

Table 1 – X8L Dielectric, (0402 - 1210 Case Sizes)

Cap	Cap Code	Series			C0402		C0603			C0805			C1206			C1210		
		Voltage Code			8	3	8	3	5	8	3	5	8	3	5	8	3	5
		Voltage DC			10	25	10	25	50	10	25	50	10	25	50	10	25	50
		Cap Tolerance			Product Availability and Chip Thickness Codes See Table 2 for Chip Thickness Dimensions													
12,000 pF	123	J	K	M	BB	BB												
15,000 pF	153	J	K	M	BB	BB												
18,000 pF	183	J	K	M	BB	BB												
22,000 pF	223	J	K	M	BB	BB												
27,000 pF	273	J	K	M	BB													
33,000 pF	333	J	K	M	BB													
39,000 pF	393	J	K	M	BB													
47,000 pF	473	J	K	M	BB		CB	CB	CB									
56,000 pF	563	J	K	M														
68,000 pF	683	J	K	M														
82,000 pF	823	J	K	M														
0.10 µF	104	J	K	M														
0.12 µF	124	J	K	M			CB	CB										
0.15 µF	154	J	K	M			CB	CB		DG	DG	DG						
0.18 µF	184	J	K	M			CB			DG	DG	DG						
0.22 µF	224	J	K	M			CB			DD	DD	DG						
0.27 µF	274	J	K	M						DD	DD							
0.33 µF	334	J	K	M						DD	DD							
0.39 µF	394	J	K	M						DE	DE		EG	EG	EG	FD	FD	FD
0.47 µF	474	J	K	M						DE	DE					FD	FD	FD
0.56 µF	564	J	K	M						DG	DH					FF	FF	FF
0.68 µF	684	J	K	M						DG	DH					FG	FG	FG
0.82 µF	824	J	K	M						DG						FL	FL	FL
1.0 µF	105	J	K	M						DG						FM	FM	FM
1.2 µF	125	J	K	M									ED	ED		FG	FG	
1.5 µF	155	J	K	M									EH	EH		FG	FG	
1.8 µF	185	J	K	M									EH	EH		FG	FG	
2.2 µF	225	J	K	M									EF	EH		FG	FG	
2.7 µF	275	J	K	M									EF			FG	FH	
3.3 µF	335	J	K	M									EH			FM	FM	
3.9 µF	395	J	K	M									EH			FG	FK	
4.7 µF	475	J	K	M									EH			FG	FS	
5.6 µF	565	J	K	M												FH		
6.8 µF	685	J	K	M												FM		
8.2 µF	825	J	K	M												FK		
10 µF	106	J	K	M												FS		
Cap	Cap Code	Voltage DC			10	25	10	25	50	10	25	50	10	25	50	10	25	50
		Voltage Code			8	3	8	3	5	8	3	5	8	3	5	8	3	5
		Series			C0402		C0603			C0805			C1206			C1210		

Table 2 – Chip Thickness/Packaging Quantities

Thickness Code	Chip Size	Thickness ± Range (mm)	QTY per Reel 7" Plastic	QTY per Reel 13" Plastic	QTY per Reel 7" Paper	QTY per Reel 13" Paper	QTY per Bulk Cassette
AA	1005	0.20 ± 0.02			15000		
AB	0201	0.30 ± 0.03			15000		
BB	0402	0.50 ± 0.05			10000	50000	50000
BC	0402	0.50 ± 0.10			10000	50000	50000
PA	0508	0.80 ± 0.10	4000	10000			
CB	0603	0.80 ± 0.07			4000	10000	15000
CC	0603	0.80 ± 0.10			4000	10000	15000
CD	0603	0.80 ± 0.15			4000	10000	15000
MA	0612	0.80 ± 0.10	4000	10000			
DB	0805	0.60 ± 0.10			4000	10000	15000
DC	0805	0.78 ± 0.10			4000	10000	15000
DD	0805	0.90 ± 0.10			4000	10000	15000
DL	0805	0.95 ± 0.10	4000	10000			
DE	0805	1.00 ± 0.10	2500	10000			
DF	0805	1.10 ± 0.10	2500	10000			
DG	0805	1.25 ± 0.15	2500	10000			
DH	0805	1.25 ± 0.20	2500	10000			
EB	1206	0.78 ± 0.10	4000	10000	4000	10000	
EK	1206	0.80 ± 0.10	2000	8000			
EC	1206	0.90 ± 0.10	4000	10000			
EN	1206	0.95 ± 0.10	4000	10000			
ED	1206	1.00 ± 0.10	2500	10000			
EE	1206	1.10 ± 0.10	2500	10000			
EF	1206	1.20 ± 0.15	2500	10000			
EM	1206	1.25 ± 0.15	2500	10000			
EG	1206	1.60 ± 0.15	2000	8000			
EH	1206	1.60 ± 0.20	2000	8000			
EJ	1206	1.70 ± 0.20	2000	8000			
FB	1210	0.78 ± 0.10	4000	10000			
FC	1210	0.90 ± 0.10	4000	10000			
FD	1210	0.95 ± 0.10	4000	10000			
FE	1210	1.00 ± 0.10	2500	10000			
FF	1210	1.10 ± 0.10	2500	10000			
FG	1210	1.25 ± 0.15	2500	10000			
FL	1210	1.40 ± 0.15	2000	8000			
FO	1210	1.50 ± 0.20	2000	8000			
FH	1210	1.55 ± 0.15	2000	8000			
FP	1210	1.60 ± 0.20	2000	8000			
FM	1210	1.70 ± 0.20	2000	8000			
FJ	1210	1.85 ± 0.20	2000	8000			
FN	1210	1.85 ± 0.20	2000	8000			
FT	1210	1.90 ± 0.20	1500	4000			
FK	1210	2.10 ± 0.20	2000	8000			
FR	1210	2.25 ± 0.20	2000	8000			
FS	1210	2.50 ± 0.20	1000	4000			
FV	1210	3.35 ± 0.10	500	1800			
FW	1210	6.15 ± 0.15	200	1000			
PA	1220	0.80 ± 0.10	4000	10000			
MA	1632	0.80 ± 0.10	4000	10000			
NA	1706	0.90 ± 0.10	4000	10000			
NB	1706	1.00 ± 0.10	4000	10000			
NC	1706	1.00 ± 0.15	4000	10000			
LD	1808	0.90 ± 0.10	2500	10000			
LE	1808	1.00 ± 0.10	2500	10000			
LF	1808	1.00 ± 0.15	2500	10000			
LA	1808	1.40 ± 0.15	1000	4000			
LB	1808	1.60 ± 0.15	1000	4000			
LC	1808	2.00 ± 0.15	1000	4000			
GB	1812	1.00 ± 0.10	1000	4000			
GC	1812	1.10 ± 0.10	1000	4000			
GD	1812	1.25 ± 0.15	1000	4000			
GE	1812	1.30 ± 0.10	1000	4000			
GH	1812	1.40 ± 0.15	1000	4000			
GF	1812	1.50 ± 0.10	1000	4000			
GG	1812	1.55 ± 0.10	1000	4000			
GK	1812	1.60 ± 0.20	1000	4000			
GJ	1812	1.70 ± 0.15	1000	4000			
GN	1812	1.70 ± 0.20	1000	4000			
GL	1812	1.90 ± 0.20	1000	4000			
GM	1812	2.00 ± 0.20	1000	4000			
GO	1812	2.50 ± 0.20	500	2000			
GP	1812	2.65 ± 0.35	500	1400			
GR	1812	5.00 ± 0.50	350	1000			
HB	1825	1.10 ± 0.15	1000	4000			
HC	1825	1.15 ± 0.15	1000	4000			
HD	1825	1.30 ± 0.15	1000	4000			
HE	1825	1.40 ± 0.15	1000	4000			
HF	1825	1.50 ± 0.15	1000	4000			
Thickness Code	Chip Size	Thickness ± Range (mm)	QTY per Reel 7" Plastic	QTY per Reel 13" Plastic	QTY per Reel 7" Paper	QTY per Reel 13" Paper	QTY per Bulk Cassette

Package Quantity
 Based on Finished Chip
 Thickness Specifications

Table 2 – Chip Thickness/Packaging Quantities con't

Thickness Code	Chip Size	Thickness ± Range (mm)	QTY per Reel 7" Plastic	QTY per Reel 13" Plastic	QTY per Reel 7" Paper	QTY per Reel 13" Paper	QTY per Bulk Cassette
HG	1825	1.60 ± 0.20	1000	4000			
JB	2220	1.00 ± 0.15	1000	4000			
JC	2220	1.10 ± 0.15	1000	4000			
JD	2220	1.30 ± 0.15	1000	4000			
JE	2220	1.40 ± 0.15	1000	4000			
JF	2220	1.50 ± 0.15	1000	4000			
JP	2220	1.60 ± 0.20	1000	4000			
JG	2220	1.70 ± 0.15	1000	4000			
JH	2220	1.80 ± 0.15	1000	4000			
JO	2220	2.40 ± 0.15	500	2000			
JP	2220	3.50 ± 0.30	250	850			
JR	2220	5.00 ± 0.50	150	600			
KB	2225	1.00 ± 0.15	1000	4000			
KC	2225	1.10 ± 0.15	1000	4000			
KD	2225	1.30 ± 0.15	1000	4000			
KE	2225	1.40 ± 0.15	1000	4000			
KF	2225	1.60 ± 0.20	1000	4000			
Thickness Code	Chip Size	Thickness ± Range (mm)	QTY per Reel 7" Plastic	QTY per Reel 13" Plastic	QTY per Reel 7" Paper	QTY per Reel 13" Paper	QTY per Bulk Cassette

Table 3A – Land Pattern Design Recommendations per IPC-7351 (Standard Termination)

EIA Size Code	Metric Size Code	Density Level A: Maximum (Most) Land Protrusion (mm)					Density Level B: Median (Nominal) Land Protrusion (mm)					Density Level C: Minimum (Least) Land Protrusion (mm)				
		C	Y	X	V1	V2	C	Y	X	V1	V2	C	Y	X	V1	V2
01005	0402	0.33	0.46	0.43	1.60	0.90	0.28	0.36	0.33	1.30	0.70	0.23	0.26	0.23	1.00	0.50
0201	0603	0.38	0.56	0.52	1.80	1.00	0.33	0.46	0.42	1.50	0.80	0.28	0.36	0.32	1.20	0.60
0402	1005	0.50	0.72	0.72	2.20	1.20	0.45	0.62	0.62	1.90	1.00	0.40	0.52	0.52	1.60	0.80
0603	1608	0.90	1.15	1.10	4.00	2.10	0.80	0.95	1.00	3.10	1.50	0.60	0.75	0.90	2.40	1.20
0805	2012	1.00	1.35	1.55	4.40	2.60	0.90	1.15	1.45	3.50	2.00	0.75	0.95	1.35	2.80	1.70
1206	3216	1.60	1.35	1.90	5.60	2.90	1.50	1.15	1.80	4.70	2.30	1.40	0.95	1.70	4.00	2.00
1210	3225	1.60	1.35	2.80	5.65	3.80	1.50	1.15	2.70	4.70	3.20	1.40	0.95	2.60	4.00	2.90
1808	4520	2.30	1.75	2.30	7.40	3.30	2.20	1.55	2.20	6.50	2.70	2.10	1.35	2.10	5.80	2.40
1812	4532	2.15	1.60	3.60	6.90	4.60	2.05	1.40	3.50	6.00	4.00	1.95	1.20	3.40	5.30	3.70
1825	4564	2.15	1.60	6.90	6.90	7.90	2.05	1.40	6.80	6.00	7.30	1.95	1.20	6.70	5.30	7.00
2220	5650	2.75	1.70	5.50	8.20	6.50	2.65	1.50	5.40	7.30	5.90	2.55	1.30	5.30	6.60	5.60
2225	5664	2.70	1.70	6.90	8.10	7.90	2.60	1.50	6.80	7.20	7.30	2.50	1.30	6.70	6.50	7.00

Density Level A: For low-density Product applications. Recommended for wave solder applications and provides a wider process window for reflow solder processes. KEMET only recommends wave soldering of EIA 0603, 0805 and 1206 case sizes.

Density Level B: For products with a moderate level of component density. Provides a robust solder attachment condition for reflow solder processes.

Density Level C: For high component density product applications. Before adapting the minimum land pattern variations the user should perform qualification testing based on the conditions outlined in IPC standard 7351 (IPC-7351).

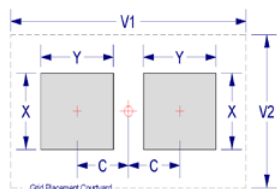

Table 3B – Land Pattern Design Recommendations per IPC-7351 (Flexible Termination)

EIA Size Code	Metric Size Code	Density Level A: Maximum (Most) Land Protrusion (mm)					Density Level B: Median (Nominal) Land Protrusion (mm)					Density Level C: Minimum (Least) Land Protrusion (mm)				
		C	Y	X	V1	V2	C	Y	X	V1	V2	C	Y	X	V1	V2
0603	1608	0.85	1.25	1.10	4.00	2.10	0.75	1.05	1.00	3.10	1.50	0.65	0.85	0.90	2.40	1.20
0805	2012	1.10	1.30	1.55	4.50	2.60	1.00	1.10	1.45	3.60	2.00	0.90	0.90	1.35	2.90	1.70
1206	3216	1.60	1.65	1.90	5.90	2.90	1.50	1.45	1.80	5.00	2.30	1.40	1.25	1.70	4.30	2.00
1210	3225	1.60	1.65	2.80	5.90	3.80	1.50	1.45	2.70	5.00	3.20	1.40	1.25	2.60	4.30	2.90
1808	4520	2.25	1.85	2.30	7.40	3.30	2.15	1.65	2.20	6.50	2.70	2.05	1.45	2.10	5.80	2.40
1812	4532	2.10	1.80	3.60	7.00	4.60	2.00	1.60	3.50	6.10	4.00	1.90	1.40	3.40	5.40	3.70
1825	4564	2.15	1.80	6.90	7.10	7.90	2.05	1.60	6.80	6.20	7.30	1.95	1.40	6.70	5.50	7.00
2220	5650	2.85	2.10	5.50	8.80	6.50	2.75	1.90	5.40	7.90	5.90	2.65	1.70	5.30	7.20	5.60
2225	5664	2.85	2.10	6.90	8.80	7.90	2.75	1.90	6.80	7.90	7.30	2.65	1.70	6.70	7.20	7.00

Density Level A: For low-density Product applications. Recommended for wave solder applications and provides a wider process window for reflow solder processes. KEMET only recommends wave soldering of EIA 0603, 0805 and 1206 case sizes.

Density Level B: For products with a moderate level of component density. Provides a robust solder attachment condition for reflow solder processes.

Density Level C: For high component density product applications. Before adapting the minimum land pattern variations the user should perform qualification testing based on the conditions outlined in IPC standard 7351 (IPC-7351).

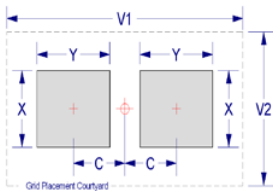

Soldering Process

Recommended Soldering Technique:

- Solder wave or solder reflow for EIA case sizes 0603, 0805 and 1206
- All other EIA case sizes are limited to solder reflow only

Recommended Soldering Profile:

- KEMET recommends following the guidelines outlined in IPC/JEDEC J-STD-020

Table 4 – Performance & Reliability: Test Methods and Conditions

Stress	Reference	Test or Inspection Method
Terminal Strength	JIS-C-6429	Appendix 1, Note: Force of 1.8kg for 60 seconds.
Board Flex	JIS-C-6429	Appendix 2, Note: 2mm (min) for all except 3mm for C0G.
Solderability	J-STD-002	Magnification 50 X. Conditions:
		a) Method B, 4 hours @ 155°C, dry heat @ 235°C
		b) Method B @ 215°C category 3
		c) Method D, category 3 @ 260°C
Temperature Cycling	JESD22 Method JA-104	1000 cycles (-55°C to +125°C). Measurement at 24 hours. +/- 2 hours after test conclusion.
Biased Humidity	MIL-STD-202 Method 103	Load Humidity: 1000 hours 85°C/85%RH and Rated Voltage. Add 100K ohm resistor. Measurement at 24 hours. +/- 2 hours after test conclusion.
		Low Volt Humidity: 1000 hours 85°C/85%RH and 1.5V. Add 100K ohm resistor. Measurement at 24 hours. +/- 2 hours after test conclusion.
Moisture Resistance	MIL-STD-202 Method 106	t = 24 hours/cycle. Steps 7a & 7b not required. Unpowered. Measurement at 24 hours. +/- 2 hours after test conclusion.
Thermal Shock	MIL-STD-202 Method 107	-55°C/+125°C. Note: Number of cycles required-300, maximum transfer time-20 seconds, dwell time-15 minutes. Air-Air.
High Temperature Life	MIL-STD-202 Method 108 / EIA -198	1000 hours at 125°C (85°C for X5R, Z5U and Y5V) with 2x rated voltage applied.
Storage Life	MIL-STD-202 Method 108	150°C, 0VDC, for 1000 hours.
Mechanical Shock	MIL-STD-202 Method 213	Figure 1 of Method 213, Condition F.
Resistance to Solvents	MIL-STD-202 Method 215	Add aqueous wash chemical - OKEM Clean or equivalent.

Storage and Handling

Ceramic chip capacitors should be stored in normal working environments. While the chips themselves are quite robust in other environments, solderability will be degraded by exposure to high temperatures, high humidity, corrosive atmospheres, and long term storage. In addition, packaging materials will be degraded by high temperature – reels may soften or warp, and tape peel force may increase. KEMET recommends that maximum storage temperature not exceed 40°C, and maximum storage humidity not exceed 70% relative humidity. In addition, temperature fluctuations should be minimized to avoid condensation on the parts, and atmospheres should be free of chlorine and sulfur bearing compounds. For optimized solderability, chip stock should be used promptly, preferably within 1.5 years of receipt.

Telecom "Tip and Ring," X7R Dielectric, 250VDC (Commercial Grade)

Overview

KEMET's 250V DC Tip and Ring MLCCs in X7R dielectric are designed and rated for telecommunication ringer circuits where the capacitor is used to block -48V to -52V DC of line voltage and pass a 16-25 Hz AC signal pulse of 70 VRMs to 90 VRMs. Serving as an excellent replacement for high voltage leaded film devices, these smaller surface mount technology footprints save valuable board space which is critical when creating new designs.

KEMET Tip and Ring capacitors feature a 125°C maximum operating temperature and are considered "temperature stable." The Electronics Components, Assemblies & Materials Association (EIA) characterizes X7R dielectric as a Class II

material. Components of this classification are fixed, ceramic dielectric capacitors suited for bypass and decoupling applications or for frequency discriminating circuits where Q and stability of capacitance characteristics are not critical. X7R dielectric exhibits a predictable change in capacitance with respect to time and voltage and boasts a minimal change in capacitance with reference to ambient temperature. Capacitance change is limited to $\pm 15\%$ from -55°C to +125°C.

These devices are able to withstand today's higher lead-free reflow processing temperatures and offer superior high frequency filtering characteristics and low ESR.

Benefits

- -55°C to +125°C operating temperature range
- Pb-Free and RoHS compliant
- EIA 0805, 1206, 1210, 1812, 1825, 2220 and 2225 case sizes
- DC voltage rating of 250V
- Capacitance offerings ranging from 1000pF to 6.8 μ F
- Available capacitance tolerances of $\pm 10\%$ and $\pm 20\%$
- Non-polar device, minimizing installation concerns
- 100% pure matte tin-plated termination finish that allows for excellent solderability
- SnPb termination finish option available upon request (5% min)
- Flexible termination option available upon request

Applications

Typical applications include telecommunication ringing circuits, switch mode power supply snubber circuits, high voltage DC blocking and high voltage coupling. Markets include telephone lines, analog and digital modems, facsimile machines, wireless base stations, cable and digital video recording set-top boxes, satellite dishes, high voltage power supply, DC/DC converters, and Ethernet, POS and ATM hardware.

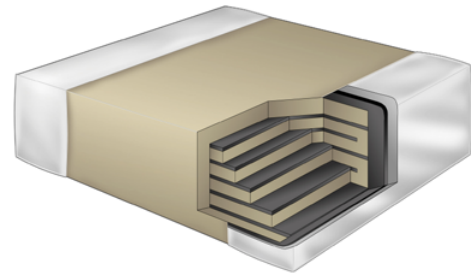

Ordering Information

C	1825	C	105	K	A	R	A	C	TU
Ceramic	Case Size (L" x W")	Specification/ Series	Capacitance Code (pF)	Capacitance Tolerance	Voltage	Dielectric	Failure Rate/ Design	Termination Finish ¹	Packaging/Grade (C-Spec) ²
	0805 1206 1210 1812 1825 2220 2225	C = Standard X = Flexible Termination	2 Sig. Digits + Number of Zeros	J = $\pm 5\%$ K = $\pm 10\%$ M = $\pm 20\%$	A = 250V	R = X7R	A = N/A	C = 100% Matte Sn L = SnPb (5% min)	Blank = Bulk TU = 7" Reel Unmarked TM = 7" Reel Marked

¹ Additional termination finish options may be available. Contact KEMET for details.

² Additional reeling or packaging options may be available. Contact KEMET for details.

Dimensions – Millimeters (Inches) Standard Termination

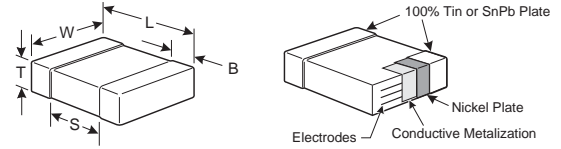

EIA Size Code	Metric Size Code	L Length	W Width	T Thickness	B Bandwidth	S Separation Minimum	Mounting Technique
0805	2012	2.00 (.079) ± 0.20 (.008)	1.25 (.049) ± 0.20 (.008)	See Table 2 for Thickness	0.50 (0.02) ± 0.25 (.010)	0.75 (.030)	Solder Wave or Solder Reflow
1206	3216	3.20 (.126) ± 0.20 (.008)	1.60 (.063) ± 0.20 (.008)		0.50 (0.02) ± 0.25 (.010)	N/A	
1210	3225	3.20 (.126) ± 0.20 (.008)	2.50 (.098) ± 0.20 (.008)		0.50 (0.02) ± 0.25 (.010)		
1812	4532	4.50 (.177) ± 0.30 (.012)	3.20 (.126) ± 0.30 (.012)		0.60 (.024) ± 0.35 (.014)		
1825	4564	4.50 (.177) ± 0.30 (.012)	6.40 (.252) ± 0.40 (.016)		0.60 (.024) ± 0.35 (.014)		
2220	5650	5.70 (.224) ± 0.40 (.016)	5.00 (.197) ± 0.40 (.016)		0.60 (.024) ± 0.35 (.014)		
2225	5664	5.60 (.220) ± 0.40 (.016)	6.40 (.248) ± 0.40 (.016)		0.60 (.024) ± 0.35 (.014)		

Dimensions – Millimeters (Inches) Flexible Termination option

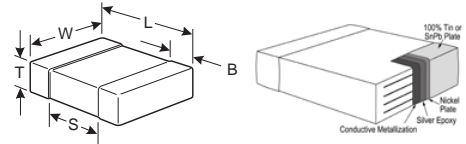

EIA Size Code	Metric Size Code	L Length	W Width	T Thickness	B Bandwidth	S Separation Minimum	Mounting Technique
0805	2012	2.10 (.083) +0.30 (.012) / -0.20 (.008)	1.25 (.049) ± 0.20 (.008)	See Table 2 for Thickness	0.50 (0.02) +0.10(.004) / -0.25 (.010)	0.50 (.020)	Solder Wave or Solder Reflow
1206	3216	3.3 (.130) ± 0.40 (.016)	1.60 (.063) ± 0.20 (.008)		0.60 (.024) ± 0.25 (.010)	0.70 (.028)	
1210	3225	3.3 (.130) ± 0.40 (.016)	2.50 (.098) ± 0.20 (.008)		0.60 (.024) ± 0.25 (.010)	N/A	Solder Reflow Only
1812	4532	4.5 (.178) ± 0.40 (.016)	3.20 (.126) ± 0.30 (.012)		0.70 (.028) ± 0.35 (.014)		
1825	4564	4.6 (.181) ± 0.40 (.016)	6.40 (.252) ± 0.40 (.016)		0.70 (.028) ± 0.35 (.014)		
2220	5650	5.9 (.232) ± 0.75 (.030)	5.00 (.197) ± 0.40 (.016)		0.70 (.028) ± 0.35 (.014)		
2225	5664	5.9 (.232) ± 0.75 (.030)	6.40 (.248) ± 0.40 (.016)		0.70 (.028) ± 0.35 (.014)		

Qualification/Certification

Commercial grade products are subject to internal qualification. Details regarding test methods and conditions are referenced in Table 4, Performance and Reliability.

Environmental Compliance

Pb-Free and RoHS compliant (excluding SnPb termination finish option)

Electrical Parameters/Characteristics

Item	Parameters/Characteristics
Operating Temperature Range	-55°C to +125°C
Capacitance Change with Reference to +25°C and 0 Vdc Applied (TCC)	±15%
Aging Rate (Max % Cap Loss/Decade Hour)	3.0%
Dielectric Withstanding Voltage	250% of rated voltage (5 ± 1 seconds and charge/discharge not exceeding 50mA)
Dissipation Factor (DF) Maximum Limits @ 25°C	5%(10V), 3.5%(16V & 25V) and 2.5%(50V–250V)
Insulation Resistance (IR) Limit @ 25°C	See Insulation Resistance Limit Table (Rated voltage applied for 120 ± 5 secs @ 25°C)

Regarding Aging Rate: Capacitance measurements (including tolerance) are indexed to a referee time of 1000 Hours.

To obtain IR limit, divide MΩ-μF value by the capacitance and compare to GΩ limit. Select the lower of the two limits.

Capacitance and Dissipation Factor (DF) measured under the following conditions:

1kHz ± 50Hz and 1.0 ± 0.2 Vrms if capacitance ≤ 10μF

120Hz ± 10Hz and 0.5 ± 0.1 Vrms if capacitance > 10μF

Note: When measuring capacitance it is important to ensure the set voltage level is held constant. The HP4284 & Agilent E4980 have a feature known as Automatic Level Control (ALC). The ALC feature should be switched to "ON".

Post Environmental Limits

High Temperature Life, Biased Humidity, Moisture Resistance					
Dielectric	Rated DC Voltage	Capacitance Value	DF (%)	Cap Shift	IR
X7R	>25	All	3.0	± 20%	10% of Initial Limit
	16 / 25		5.0		
	< 16		7.5		

Insulation Resistance Limit Table

EIA Case Size	1000 megohm microfarads or 100GΩ	500 megohm microfarads or 10GΩ
0201	N/A	ALL
0402	< .012μF	≥ .012μF
0603	< .047μF	≥ .047μF
0805	< .047μF	≥ .047μF
1206	< 0.22μF	≥ 0.22μF
1210	< 0.39μF	≥ 0.39μF
1808	ALL	N/A
1812	< 2.2μF	≥ 2.2μF
1825	ALL	N/A
2220	< 10μF	≥ 10μF
2225	ALL	N/A

Table 1 – “Tip and Ring,” X7R Dielectric, (0805 - 2225 Case Sizes)

Cap	Cap Tol.	Series			C0805C	C1206C	C1210C	C1812C	C1825C	C2220C	C2225C
		Voltage Code			A	A	A	A	A	A	A
		Voltage DC			250	250	250	250	250	250	250
		Cap Tolerance			Product Availability and Chip Thickness Codes - See Table 2 for Chip Thickness Dimensions						
150 pF	151	J	K	M							
180 pF	181	J	K	M	DC						
220 pF	221	J	K	M	DC						
270 pF	271	J	K	M	DC						
330 pF	331	J	K	M	DC						
390 pF	391	J	K	M	DC						
470 pF	471	J	K	M	DC						
560 pF	561	J	K	M	DC						
680 pF	681	J	K	M	DC						
820 pF	821	J	K	M	DC						
1,000 pF	102	J	K	M	DC	EB					
1,200 pF	122	J	K	M	DC	EB					
1,500 pF	152	J	K	M	DC	EB					
1,800 pF	182	J	K	M	DC	EB					
2,200 pF	222	J	K	M	DC	EB	FB				
2,700 pF	272	J	K	M	DC	EB	FB				
3,300 pF	332	J	K	M	DC	EB	FB				
3,900 pF	392	J	K	M	DC	EB	FB				
4,700 pF	472	J	K	M	DC	EB	FB				
5,600 pF	562	J	K	M	DC	EB	FB				
6,800 pF	682	J	K	M	DC	EB	FB	GB			
8,200 pF	822	J	K	M	DC	EB	FB	GB			
10,000 pF	103	J	K	M	DC	EB	FB	GB			
12,000 pF	123	J	K	M	DC	EB	FB	GB			
15,000 pF	153	J	K	M	DC	EB	FB	GB			
18,000 pF	183	J	K	M	DC	EB	FB	GB			
22,000 pF	223	J	K	M	DC	EB	FB	GB	HB		
27,000 pF	273	J	K	M		EB	FB	GB	HB		
33,000 pF	333	J	K	M		EB	FB	GB	HB		
39,000 pF	393	J	K	M		EB	FB	GB	HB		
47,000 pF	473	J	K	M		ED	FC	GB	HB	KC	
56,000 pF	563	J	K	M		ED	FC	GB	HB	KC	
68,000 pF	683	J	K	M		ED	FC	GB	HB	KC	
82,000 pF	823	J	K	M		ED	FF	GB	HB	JC	
0.10 µF	104	J	K	M		EM	FG	GB	HB	JC	
0.12 µF	124	J	K	M				GB	HB	JC	
0.15 µF	154	J	K	M				GE	HB	JC	
0.18 µF	184	J	K	M				GG	HB	JC	
0.22 µF	224	J	K	M				GG	HB	JC	
0.27 µF	274	J	K	M				GG	HB	JC	
0.33 µF	334	J	K	M				GG	HB	JC	
0.39 µF	394	J	K	M				GG	HD	JC	
0.47 µF	474	J	K	M				GJ	HD	JC	
0.56 µF	564	J	K	M					HD	JD	
0.68 µF	684	J	K	M					HD	JD	
0.82 µF	824	J	K	M					HF	JF	
1.0 µF	105	J	K	M					HF	JF	
1.2 µF	125	J	K	M							
1.5 µF	155	J	K	M							
1.8 µF	185	J	K	M							
2.2 µF	225	J	K	M							
2.7 µF	275	J	K	M							
3.3 µF	335	J	K	M							
3.9 µF	395	J	K	M							
4.7 µF	475	J	K	M							
Cap	Cap Tol.	Voltage DC			250	250	250	250	250	250	250
		Voltage Code			A	A	A	A	A	A	A
		Series			C0805C	C1206C	C1210C	C1812C	C1825C	C2220C	C2225C

Open Mode Design (FO-CAP), X7R Dielectric, 16VDC-200VDC (Commercial & Automotive Grade)

Overview

KEMET's Ceramic Open Mode capacitor in X7R dielectric is designed to significantly minimize the probability of a low IR or short circuit condition when forced to failure in a board stress flex situation, thus reducing the potential for catastrophic failure. The Open Mode capacitor may experience a drop in capacitance; however, a short is unlikely because a crack will not typically propagate across counter electrodes within the device's "active area." Since there will not be any current leakage associated with a typical Open Mode flex crack, there is no localized heating and therefore little chance for a catastrophic and potentially costly failure event.

Driven by the demand for a more robust and reliable component, the Open Mode capacitor was designed for critical applications where higher operating temperatures and mechanical stress are

a concern. These capacitors are manufactured in state of the art ISO/TS 16949:2002 certified facilities and are widely used in automotive circuits as well as power supplies (input and output filters) and general electronic applications.

When combined with flexible termination technology these devices offer the ultimate level of protection against a low IR or short circuit condition. Open Mode devices compliment KEMET's Floating Electrode (FE-CAP) and Floating Electrode with Flexible Termination (FF-CAP) product lines by providing a fail-safe design optimized for mid to high range capacitance values. These devices exhibit a predictable change in capacitance with respect to time and voltage and boast a minimal change in capacitance with reference to ambient temperature. Capacitance change is limited to $\pm 15\%$ from -55°C to $+125^{\circ}\text{C}$.

Benefits

- -55°C to $+125^{\circ}\text{C}$ operating temperature range
- Open Mode/fail open design
- Mid to high capacitance flex mitigation
- Pb-Free and RoHS compliant
- EIA 0805, 1206, 1210 and 1812 case sizes
- DC voltage ratings of 16V, 25V, 50V, 100V and 200V
- Capacitance offerings ranging from 1000pF to 6.8 μF
- Available capacitance tolerances of $\pm 5\%$, $\pm 10\%$ and $\pm 20\%$
- Non-polar device, minimizing installation concerns
- 100% pure matte tin-plated termination finish allowing for excellent solderability

- SnPb termination finish option available upon request (5% min)
- Commercial and Automotive (AEC-Q200) grades available
- SnPb termination finish option available upon request (5% min)
- Flexible termination option available upon request

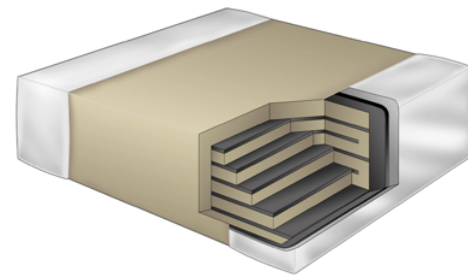

Ordering Information

C	1210	J	685	K	3	R	A	C	TU
Ceramic	Case Size (L" x W")	Specification/ Series	Capacitance Code (pF)	Capacitance Tolerance	Voltage	Dielectric	Failure Rate/ Design	Termination Finish ¹	Packaging/Grade (C-Spec) ²
	0805 1206 1210 1812	F = Open Mode J = Open Mode w/Flexible Termination	2 Sig. Digits + Number of Zeros	K = $\pm 10\%$ M = $\pm 20\%$	4 = 16V 3 = 25V 5 = 50V 1 = 100V 2 = 200V	R = X7R	A = N/A	C = 100% Matte Sn L = SnPb (5% min)	Blank = Bulk TU = 7" Reel Unmarked TM = 7" Reel Marked AUTO = Automotive Grade

¹ Additional termination finish options may be available. Contact KEMET for details.

^{1,2} SnPb termination finish option is not available on automotive grade product.

² Additional reeling or packaging options may be available. Contact KEMET for details.

Dimensions – Standard Termination – Millimeters (Inches)

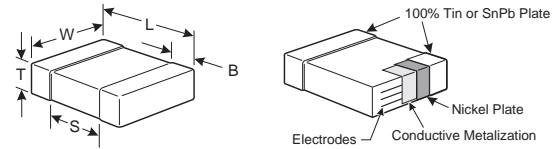

EIA Size Code	Metric Size Code	L Length	W Width	T Thickness	B Bandwidth	S Separation Min.	Mounting Technique
0805	2012	2.00 (.079) ± 0.20 (.008)	1.25 (.049) ± 0.20 (.008)	See Table 2 for Thickness	0.50 (0.02) ± 0.25 (.010)	0.75 (.030)	Solder Wave or Solder Reflow
1206	3216	3.20 (.126) ± 0.20 (.008)	1.60 (.063) ± 0.20 (.008)		0.50 (0.02) ± 0.25 (.010)	N/A	
1210	3225	3.20 (.126) ± 0.20 (.008)	2.50 (.098) ± 0.20 (.008)		0.50 (0.02) ± 0.25 (.010)		
1812	4532	4.50 (.177) ± 0.30 (.012)	3.20 (.126) ± 0.30 (.012)		0.60 (.024) ± 0.35 (.014)		Solder Reflow Only

Dimensions – Flexible Termination – Millimeters (Inches)

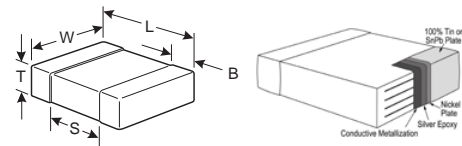

EIA Size Code	Metric Size Code	L Length	W Width	T Thickness	B Bandwidth	S Separation Min.	Mounting Technique
0805	2012	2.10 (.083) +0.30 (.012) / -0.20 (.008)	1.25 (.049) ± 0.20 (.008)	See Table 2 for Thickness	0.50 (0.02) +0.10 (.004) / -0.25 (.010)	0.70 (.028)	Solder Wave or Solder Reflow
1206	3216	3.30 (.130) ± 0.40 (.016)	1.60 (.063) ± 0.20 (.008)		0.60 (.024) ± 0.25 (.010)	N/A	
1210	3225	3.30 (.130) ± 0.40 (.016)	2.50 (.098) ± 0.20 (.008)		0.60 (.024) ± 0.25 (.010)		
1812	4532	4.50 (.178) ± 0.40 (.016)	3.20 (.126) ± 0.30 (.012)		0.70 (.028) ± 0.35 (.014)		Solder Reflow Only

Applications

Typical applications include input side filtering (power plane/bus), high current (battery line) and circuits that cannot be fused to open when short circuits occur due to flex cracks. Markets include automotive applications that are directly connected to the battery and/or involve conversion to a 42V system and raw power input side filtering in power conversion.

Qualification/Certification

Commercial grade products are subject to internal qualification. Details regarding test methods and conditions are referenced in Table 4, Performance and Reliability.

Automotive grade products meet or exceed the requirements outlined by the Automotive Electronics Council. Details regarding test methods and conditions are referenced in document AEC-Q200, Stress Test Qualification for Passive Components. For additional information regarding the Automotive Electronics Council and AEC-Q200, please visit their website at www.aecouncil.com.

Environmental Compliance

Pb-Free and RoHS compliant (excluding SnPb termination finish option).

Electrical Parameters/Characteristics

Item	Parameters/Characteristics
Operating Temperature Range	-55°C to +125°C
Capacitance Change with Reference to +25°C and 0 Vdc Applied (TCC)	±15%
Aging Rate (Max % Cap Loss/Decade Hour)	3.0%
Dielectric Withstanding Voltage	250% of rated voltage (5 ± 1 seconds and charge/discharge not exceeding 50mA)
Dissipation Factor (DF) Maximum Limits @ 25°C	5% (10V), 3.5% (16V & 25V) and 2.5% (50V to 250V)
Insulation Resistance (IR) Limit @ 25°C	See Insulation Resistance Limit Table (Rated voltage applied for 120 ± 5 secs @ 25°C)

Regarding Aging Rate: Capacitance measurements (including tolerance) are indexed to a referee time of 1000 hours.

To obtain IR limit, divide $M\Omega\text{-}\mu F$ value by the capacitance and compare to $G\Omega$ limit. Select the lower of the two limits.

Capacitance and Dissipation Factor (DF) measured under the following conditions:

1kHz ± 50Hz and 1.0 ± 0.2 Vrms if capacitance $\leq 10\mu F$

120Hz ± 10Hz and 0.5 ± 0.1 Vrms if capacitance $> 10\mu F$

Note: When measuring capacitance it is important to ensure the set voltage level is held constant. The HP4284 & Agilent E4980 have a feature known as Automatic Level Control (ALC). The ALC feature should be switched to "ON."

Post Environmental Limits

High Temperature Life, Biased Humidity, Moisture Resistance					
Dielectric	Rated DC Voltage	Capacitance Value	DF (%)	Cap Shift	IR
X7R	>25	All	3.0	± 20%	10% of Initial Limit
	16 / 25		5.0		
	< 16		7.5		

Insulation Resistance Limit Table

EIA Case Size	1000 megohm microfarads or 100GΩ	500 megohm microfarads or 10GΩ
0201	N/A	ALL
0402	< .012μF	≥ .012μF
0603	< .047μF	≥ .047μF
0805	< .047μF	≥ .047μF
1206	< 0.22μF	≥ 0.22μF
1210	< 0.39μF	≥ 0.39μF
1808	ALL	N/A
1812	< 2.2μF	≥ 2.2μF
1825	ALL	N/A
2220	< 10μF	≥ 10μF
2225	ALL	N/A

Table 1 – Open Mode Design, X7R Dielectric, (0805 - 1812 Case Sizes)

Cap	Cap Code	Series		C0805F/J					C1206F/J					C1210F/J					C1812F/J			
		Voltage Code		4	3	5	1	2	4	3	5	1	2	4	3	5	1	2	3	5	1	2
		Voltage DC		16	25	50	100	200	16	25	50	100	200	16	25	50	100	200	25	50	100	200
		Cap Tolerance		Product Availability and Chip Thickness Codes - See Table 2 for Chip Thickness Dimensions																		
1,000 pF	102	K	M	DD	DD	DD	DD	DD														
1,200 pF	122	K	M	DD	DD	DD	DD	DD														
1,500 pF	152	K	M	DD	DD	DD	DD	DD														
1,800 pF	182	K	M	DD	DD	DD	DD	DD														
2,200 pF	222	K	M	DD	DD	DD	DD	DD														
2,700 pF	272	K	M	DD	DD	DD	DD	DD														
3,300 pF	332	K	M	DD	DD	DD	DD	DD														
3,900 pF	392	K	M	DD	DD	DD	DD	DD														
4,700 pF	472	K	M	DD	DD	DD	DD	DD														
5,600 pF	562	K	M	DD	DD	DD	DD	DD														
6,800 pF	682	K	M	DD	DD	DD	DD	DD														
8,200 pF	822	K	M	DD	DD	DD	DD	DD														
10,000 pF	103	K	M	DD	DD	DD	DD	DD														
12,000 pF	123	K	M	DD	DD	DD	DD	DG														
15,000 pF	153	K	M	DD	DD	DD	DD	DG														
18,000 pF	183	K	M	DD	DD	DD	DD		EC	EC	EC	EC	EC									
22,000 pF	223	K	M	DD	DD	DD	DG		EC	EC	EC	EC	EC									
27,000 pF	273	K	M	DD	DD	DD	DG		EC	EC	EC	EC	EC									
33,000 pF	333	K	M	DD	DD	DD	DG		EC	EC	EC	EC	EC									
39,000 pF	393	K	M	DD	DD	DD	DG		EC	EC	EC	EC	EC									
47,000 pF	473	K	M	DD	DD	DD	DE		EC	EC	EC	EC	EG					GB	GB	GB	GB	
56,000 pF	563	K	M	DD	DD	DD			EC	EC	EC	EC	EG					GB	GB	GB	GB	
68,000 pF	683	K	M	DD	DD	DG	DG		EC	EC	EC	EC	EG	FD	FD	FD	FD	FD	FD	FD	FD	
82,000 pF	823	K	M	DD	DD	DG			EC	EC	EC	EC	EG	FD	FD	FD	FD	FD	FD	FD	FD	
0.10 µF	104	K	M	DG	DG	DG			EC	EC	EC	EC	EG	FD	FD	FD	FD	FD	FD	FD	FD	
0.12 µF	124	K	M	DG	DG				EC	EC	EC	EC		FD	FD	FD	FD	FG				
0.15 µF	154	K	M	DG	DG				EC	EC	EC	EG		FD	FD	FD	FD	FH				
0.18 µF	184	K	M	DG	DG				EC	EC	EC	EG		FD	FD	FD	FD	FH				
0.22 µF	224	K	M	DG	DD	DG			EC	EC	EC	ED		FD	FD	FD	FD	FJ				
0.27 µF	274	K	M	DD	DD				EC	EC	EC			FD	FD	FD	FG					
0.33 µF	334	K	M	DD	DG				EG	EG	EG	EG		FD	FD	FD	FH					
0.39 µF	394	K	M	DD	DG				EG	EG				FD	FD	FG	FH					
0.47 µF	474	K	M	DE	DG				EG	EG	EC			FD	FD	FG	FJ					
0.56 µF	564	K	M						EG					FD	FD	FG	FR					
0.68 µF	684	K	M	DG					EG					FD	FG	FH	FR					
0.82 µF	824	K	M						EG					FD	FG	FH						
1.0 µF	105	K	M						EG	EC	EH			FD	FH	FJ	FS					
1.2 µF	125	K	M											FG								
1.5 µF	155	K	M											FH								
1.8 µF	185	K	M											FH								
2.2 µF	225	K	M						EC	EH				FJ	FM	FM						
2.7 µF	275	K	M																			
3.3 µF	335	K																				
3.9 µF	395	K	M																			
4.7 µF	475	K	M						EH					FG	FM							
6.8 µF	685	K	M											FS	FS							
Cap	Cap Code	Voltage DC		16	25	50	100	200	16	25	50	100	200	16	25	50	100	200	25	50	100	200
		Voltage Code		4	3	5	1	2	4	3	5	1	2	4	3	5	1	2	3	5	1	2
		Series		C0805F					C1206F					C1210F					C1812F			

Table 2 – Chip Thickness/Packaging Quantities

Thickness Code	Chip Size	Thickness ± Range (mm)	QTY per Reel 7" Plastic	QTY per Reel 13" Plastic	QTY per Reel 7" Paper	QTY per Reel 13" Paper	QTY per Bulk Cassette
AA	1005	0.20 ± 0.02			15000		
AB	0201	0.30 ± 0.03			15000		
BB	0402	0.50 ± 0.05			10000	50000	50000
BC	0402	0.50 ± 0.10			10000	50000	50000
PA	0508	0.80 ± 0.10	4000	10000			
CB	0603	0.80 ± 0.07			4000	10000	15000
CC	0603	0.80 ± 0.10			4000	10000	15000
CD	0603	0.80 ± 0.15			4000	10000	15000
MA	0612	0.80 ± 0.10	4000	10000			
DB	0805	0.60 ± 0.10			4000	10000	15000
DC	0805	0.78 ± 0.10			4000	10000	15000
DD	0805	0.90 ± 0.10			4000	10000	15000
DL	0805	0.95 ± 0.10	4000	10000			
DE	0805	1.00 ± 0.10	2500	10000			
DF	0805	1.10 ± 0.10	2500	10000			
DG	0805	1.25 ± 0.15	2500	10000			
DH	0805	1.25 ± 0.20	2500	10000			
EB	1206	0.78 ± 0.10	4000	10000	4000	10000	
EK	1206	0.80 ± 0.10	2000	8000			
EC	1206	0.90 ± 0.10	4000	10000			
EN	1206	0.95 ± 0.10	4000	10000			
ED	1206	1.00 ± 0.10	2500	10000			
EE	1206	1.10 ± 0.10	2500	10000			
EF	1206	1.20 ± 0.15	2500	10000			
EM	1206	1.25 ± 0.15	2500	10000			
EG	1206	1.60 ± 0.15	2000	8000			
EH	1206	1.60 ± 0.20	2000	8000			
EJ	1206	1.70 ± 0.20	2000	8000			
FB	1210	0.78 ± 0.10	4000	10000			
FC	1210	0.90 ± 0.10	4000	10000			
FD	1210	0.95 ± 0.10	4000	10000			
FE	1210	1.00 ± 0.10	2500	10000			
FF	1210	1.10 ± 0.10	2500	10000			
FG	1210	1.25 ± 0.15	2500	10000			
FL	1210	1.40 ± 0.15	2000	8000			
FO	1210	1.50 ± 0.20	2000	8000			
FH	1210	1.55 ± 0.15	2000	8000			
FP	1210	1.60 ± 0.20	2000	8000			
FM	1210	1.70 ± 0.20	2000	8000			
FJ	1210	1.85 ± 0.20	2000	8000			
FN	1210	1.85 ± 0.20	2000	8000			
FT	1210	1.90 ± 0.20	1500	4000			
FK	1210	2.10 ± 0.20	2000	8000			
FR	1210	2.25 ± 0.20	2000	8000			
FS	1210	2.50 ± 0.20	1000	4000			
FV	1210	3.35 ± 0.10	500	1800			
FW	1210	6.15 ± 0.15	200	1000			
PA	1220	0.80 ± 0.10	4000	10000			
MA	1632	0.80 ± 0.10	4000	10000			
NA	1706	0.90 ± 0.10	4000	10000			
NB	1706	1.00 ± 0.10	4000	10000			
NC	1706	1.00 ± 0.15	4000	10000			
LD	1808	0.90 ± 0.10	2500	10000			
LE	1808	1.00 ± 0.10	2500	10000			
LF	1808	1.00 ± 0.15	2500	10000			
LA	1808	1.40 ± 0.15	1000	4000			
LB	1808	1.60 ± 0.15	1000	4000			
LC	1808	2.00 ± 0.15	1000	4000			
GB	1812	1.00 ± 0.10	1000	4000			
GC	1812	1.10 ± 0.10	1000	4000			
GD	1812	1.25 ± 0.15	1000	4000			
GE	1812	1.30 ± 0.10	1000	4000			
GH	1812	1.40 ± 0.15	1000	4000			
GF	1812	1.50 ± 0.10	1000	4000			
GG	1812	1.55 ± 0.10	1000	4000			
GK	1812	1.60 ± 0.20	1000	4000			
GJ	1812	1.70 ± 0.15	1000	4000			
GN	1812	1.70 ± 0.20	1000	4000			
GL	1812	1.90 ± 0.20	1000	4000			
GM	1812	2.00 ± 0.20	1000	4000			
GO	1812	2.50 ± 0.20	500	2000			
GP	1812	2.65 ± 0.35	500	1400			
GR	1812	5.00 ± 0.50	350	1000			
HB	1825	1.10 ± 0.15	1000	4000			
HC	1825	1.15 ± 0.15	1000	4000			
HD	1825	1.30 ± 0.15	1000	4000			
HE	1825	1.40 ± 0.15	1000	4000			
HF	1825	1.50 ± 0.15	1000	4000			
Thickness Code	Chip Size	Thickness ± Range (mm)	QTY per Reel 7" Plastic	QTY per Reel 13" Plastic	QTY per Reel 7" Paper	QTY per Reel 13" Paper	QTY per Bulk Cassette

Package Quantity
 Based on Finished Chip
 Thickness Specifications

Table 2 – Chip Thickness/Packaging Quantities cont'

Thickness Code	Chip Size	Thickness ± Range (mm)	QTY per Reel 7" Plastic	QTY per Reel 13" Plastic	QTY per Reel 7" Paper	QTY per Reel 13" Paper	QTY per Bulk Cassette
HG	1825	1.60 ± 0.20	1000	4000			
JB	2220	1.00 ± 0.15	1000	4000			
JC	2220	1.10 ± 0.15	1000	4000			
JD	2220	1.30 ± 0.15	1000	4000			
JE	2220	1.40 ± 0.15	1000	4000			
JF	2220	1.50 ± 0.15	1000	4000			
JP	2220	1.60 ± 0.20	1000	4000			
JG	2220	1.70 ± 0.15	1000	4000			
JH	2220	1.80 ± 0.15	1000	4000			
JO	2220	2.40 ± 0.15	500	2000			
JP	2220	3.50 ± 0.30	250	850			
JR	2220	5.00 ± 0.50	150	600			
KB	2225	1.00 ± 0.15	1000	4000			
KC	2225	1.10 ± 0.15	1000	4000			
KD	2225	1.30 ± 0.15	1000	4000			
KE	2225	1.40 ± 0.15	1000	4000			
KF	2225	1.60 ± 0.20	1000	4000			
Thickness Code	Chip Size	Thickness ± Range (mm)	QTY per Reel 7" Plastic	QTY per Reel 13" Plastic	QTY per Reel 7" Paper	QTY per Reel 13" Paper	QTY per Bulk Cassette

Table 3A – Land Pattern Design Recommendations per IPC-7351 (Standard Termination)

EIA Size Code	Metric Size Code	Density Level A: Maximum (Most) Land Protrusion (mm)					Density Level B: Median (Nominal) Land Protrusion (mm)					Density Level C: Minimum (Least) Land Protrusion (mm)				
		C	Y	X	V1	V2	C	Y	X	V1	V2	C	Y	X	V1	V2
01005	0402	0.33	0.46	0.43	1.60	0.90	0.28	0.36	0.33	1.30	0.70	0.23	0.26	0.23	1.00	0.50
0201	0603	0.38	0.56	0.52	1.80	1.00	0.33	0.46	0.42	1.50	0.80	0.28	0.36	0.32	1.20	0.60
0402	1005	0.50	0.72	0.72	2.20	1.20	0.45	0.62	0.62	1.90	1.00	0.40	0.52	0.52	1.60	0.80
0603	1608	0.90	1.15	1.10	4.00	2.10	0.80	0.95	1.00	3.10	1.50	0.60	0.75	0.90	2.40	1.20
0805	2012	1.00	1.35	1.55	4.40	2.60	0.90	1.15	1.45	3.50	2.00	0.75	0.95	1.35	2.80	1.70
1206	3216	1.60	1.35	1.90	5.60	2.90	1.50	1.15	1.80	4.70	2.30	1.40	0.95	1.70	4.00	2.00
1210	3225	1.60	1.35	2.80	5.65	3.80	1.50	1.15	2.70	4.70	3.20	1.40	0.95	2.60	4.00	2.90
1808	4520	2.30	1.75	2.30	7.40	3.30	2.20	1.55	2.20	6.50	2.70	2.10	1.35	2.10	5.80	2.40
1812	4532	2.15	1.60	3.60	6.90	4.60	2.05	1.40	3.50	6.00	4.00	1.95	1.20	3.40	5.30	3.70
1825	4564	2.15	1.60	6.90	6.90	7.90	2.05	1.40	6.80	6.00	7.30	1.95	1.20	6.70	5.30	7.00
2220	5650	2.75	1.70	5.50	8.20	6.50	2.65	1.50	5.40	7.30	5.90	2.55	1.30	5.30	6.60	5.60
2225	5664	2.70	1.70	6.90	8.10	7.90	2.60	1.50	6.80	7.20	7.30	2.50	1.30	6.70	6.50	7.00

Density Level A: For low-density Product applications. Recommended for wave solder applications and provides a wider process window for reflow solder processes. KEMET only recommends wave soldering of EIA 0603, 0805 and 1206 case sizes.

Density Level B: For products with a moderate level of component density. Provides a robust solder attachment condition for reflow solder processes.

Density Level C: For high component density product applications. Before adapting the minimum land pattern variations the user should perform qualification testing based on the conditions outlined in IPC standard 7351 (IPC-7351).

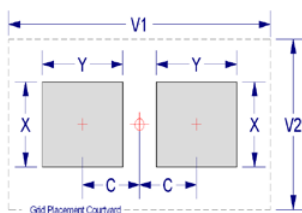

Table 3B – Land Pattern Design Recommendations per IPC-7351 (Flexible Termination)

EIA Size Code	Metric Size Code	Density Level A: Maximum (Most) Land Protrusion (mm)					Density Level B: Median (Nominal) Land Protrusion (mm)					Density Level C: Minimum (Least) Land Protrusion (mm)				
		C	Y	X	V1	V2	C	Y	X	V1	V2	C	Y	X	V1	V2
0603	1608	0.85	1.25	1.10	4.00	2.10	0.75	1.05	1.00	3.10	1.50	0.65	0.85	0.90	2.40	1.20
0805	2012	1.10	1.30	1.55	4.50	2.60	1.00	1.10	1.45	3.60	2.00	0.90	0.90	1.35	2.90	1.70
1206	3216	1.60	1.65	1.90	5.90	2.90	1.50	1.45	1.80	5.00	2.30	1.40	1.25	1.70	4.30	2.00
1210	3225	1.60	1.65	2.80	5.90	3.80	1.50	1.45	2.70	5.00	3.20	1.40	1.25	2.60	4.30	2.90
1808	4520	2.25	1.85	2.30	7.40	3.30	2.15	1.65	2.20	6.50	2.70	2.05	1.45	2.10	5.80	2.40
1812	4532	2.10	1.80	3.60	7.00	4.60	2.00	1.60	3.50	6.10	4.00	1.90	1.40	3.40	5.40	3.70
1825	4564	2.15	1.80	6.90	7.10	7.90	2.05	1.60	6.80	6.20	7.30	1.95	1.40	6.70	5.50	7.00
2220	5650	2.85	2.10	5.50	8.80	6.50	2.75	1.90	5.40	7.90	5.90	2.65	1.70	5.30	7.20	5.60
2225	5664	2.85	2.10	6.90	8.80	7.90	2.75	1.90	6.80	7.90	7.30	2.65	1.70	6.70	7.20	7.00

Density Level A: For low-density Product applications. Recommended for wave solder applications and provides a wider process window for reflow solder processes. KEMET only recommends wave soldering of EIA 0603, 0805 and 1206 case sizes.

Density Level B: For products with a moderate level of component density. Provides a robust solder attachment condition for reflow solder processes.

Density Level C: For high component density product applications. Before adapting the minimum land pattern variations the user should perform qualification testing based on the conditions outlined in IPC standard 7351 (IPC-7351).

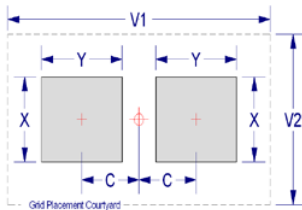

Soldering Process

Recommended Soldering Technique:

- Solder wave or solder reflow for EIA case sizes 0603, 0805 and 1206
- All other EIA case sizes are limited to solder reflow only

Recommended Soldering Profile:

- KEMET recommends following the guidelines outlined in IPC/JEDEC J-STD-020

Table 4 – Performance & Reliability: Test Methods and Conditions

Stress	Reference	Test or Inspection Method
Terminal Strength	JIS-C-6429	Appendix 1, Note: Force of 1.8kg for 60 seconds.
Board Flex	JIS-C-6429	Appendix 2, Note: 2mm (min) for all except 3mm for C0G.
Solderability	J-STD-002	Magnification 50 X. Conditions:
		a) Method B, 4 hours @ 155°C, dry heat @ 235°C
		b) Method B @ 215°C category 3
		c) Method D, category 3 @ 260°C
Temperature Cycling	JESD22 Method JA-104	1000 cycles (-55°C to +125°C). Measurement at 24 hours. +/- 2 hours after test conclusion.
Biased Humidity	MIL-STD-202 Method 103	Load Humidity: 1000 hours 85°C/85%RH and Rated Voltage. Add 100K ohm resistor. Measurement at 24 hours. +/- 2 hours after test conclusion.
		Low Volt Humidity: 1000 hours 85°C/85%RH and 1.5V. Add 100K ohm resistor. Measurement at 24 hours. +/- 2 hours after test conclusion.
Moisture Resistance	MIL-STD-202 Method 106	t = 24 hours/cycle. Steps 7a & 7b not required. Unpowered. Measurement at 24 hours. +/- 2 hours after test conclusion.
Thermal Shock	MIL-STD-202 Method 107	-55°C/+125°C. Note: Number of cycles required-300, maximum transfer time-20 seconds, dwell time-15 minutes. Air-Air.
High Temperature Life	MIL-STD-202 Method 108 / EIA -198	1000 hours at 125°C (85°C for X5R, Z5U and Y5V) with 2x rated voltage applied.
Storage Life	MIL-STD-202 Method 108	150°C, 0VDC, for 1000 hours.
Mechanical Shock	MIL-STD-202 Method 213	Figure 1 of Method 213, Condition F.
Resistance to Solvents	MIL-STD-202 Method 215	Add aqueous wash chemical - OKEM Clean or equivalent.

Storage and Handling

Ceramic chip capacitors should be stored in normal working environments. While the chips themselves are quite robust in other environments, solderability will be degraded by exposure to high temperatures, high humidity, corrosive atmospheres, and long term storage. In addition, packaging materials will be degraded by high temperature – reels may soften or warp, and tape peel force may increase. KEMET recommends that maximum storage temperature not exceed 40°C, and maximum storage humidity not exceed 70% relative humidity. In addition, temperature fluctuations should be minimized to avoid condensation on the parts, and atmospheres should be free of chlorine and sulfur bearing compounds. For optimized solderability, chip stock should be used promptly, preferably within 1.5 years of receipt.

Floating Electrode Design (FE-CAP) X7R Dielectric 6.3VDC-250VDC (Commercial Grade)

Overview

KEMET's Floating Electrode (FE-CAP) multilayer ceramic capacitor in X7R dielectric utilizes a cascading internal electrode design configured to form multiple capacitors in series within a single monolithic structure. This unique configuration results in enhanced voltage and ESD performance over standard capacitor designs while allowing for a fail-open condition if mechanically damaged (cracked). If damaged, the device may experience a drop in capacitance but a short is unlikely. The FE-CAP is designed to reduce the likelihood of a low IR or short circuit condition and the chance for a catastrophic and potentially costly failure event.

Driven by the demand for a more robust and reliable component, the FE-CAP was designed for critical applications where

higher operating temperatures and mechanical stress are a concern. These capacitors are manufactured in state of the art ISO/TS 16949:2002 certified facilities and are widely used in power supplies (input and output filters) and general electronic applications.

Combined with the stability of an X7R dielectric, the FE-CAP complements KEMET's "Open Mode" devices by providing a fail-safe design optimized for low to mid range capacitance values. These devices exhibit a predictable change in capacitance with respect to time and voltage and boast a minimal change in capacitance with reference to ambient temperature. Capacitance change is limited to $\pm 15\%$ from -55°C to $+125^{\circ}\text{C}$.

Benefits

- -55°C to $+125^{\circ}\text{C}$ operating temperature range
- Floating Electrode/fail open design
- Low to mid capacitance flex mitigation
- Pb-Free and RoHS compliant
- EIA 0402, 0603, 0805, 1206, 1210, and 1812 case sizes
- DC voltage ratings of 6.3V, 10V, 16V, 25V, 50V, 100V, 200V, and 250V
- Capacitance offerings ranging from 150pF to 0.22 μF
- Available capacitance tolerances of $\pm 5\%$, $\pm 10\%$ and $\pm 20\%$
- Non-polar device, minimizing installation concerns
- 100% pure matte tin-plated termination finish allowing for excellent solderability
- SnPb termination finish option available upon request (5% min)

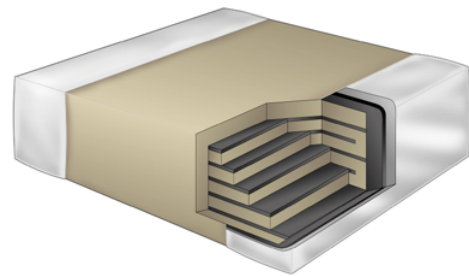

Ordering Information

C	0805	S	104	K	5	R	A	C	TU
Ceramic	Case Size (L" x W")	Specification/ Series	Capacitance Code (pF)	Capacitance Tolerance	Voltage	Dielectric	Failure Rate/ Design	Termination Finish ¹	Packaging/Grade (C-Spec) ²
	0402 0603 0805 1206 1210 1812	S = Floating Electrode	2 Sig. Digits + Number of Zeros	J = $\pm 5\%$ K = $\pm 10\%$ M = $\pm 20\%$	9 = 6.3V 8 = 10V 4 = 16V 3 = 25V 6 = 35V 5 = 50V 1 = 100V 2 = 200V A = 250V	R = X7R	A = N/A	C = 100% Matte Sn L = SnPb (5% min)	Blank = Bulk TU = 7" Reel Unmarked TM = 7" Reel Marked

¹ Additional termination finish options may be available. Contact KEMET for details.

² Additional reeling or packaging options may be available. Contact KEMET for details.

Dimensions – Millimeters (Inches)

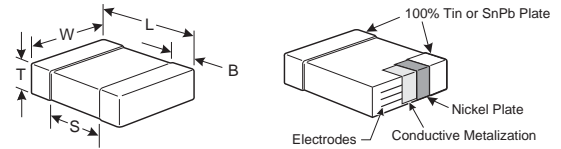

EIA Size Code	Metric Size Code	L Length	W Width	T Thickness	B Bandwidth	S Separation Min.	Mounting Technique
0402	1005	1.00 (.040) ± 0.05 (.002)	0.50 (.020) ± 0.05 (.002)	See Table 2 for Thickness	0.30 (.012) ± 0.10 (.004)	0.30 (.012)	Solder Reflow Only
0603	1608	1.60 (.063) ± 0.15 (.006)	0.80 (.032) ± 0.15 (.006)		0.35 (.014) ± 0.15 (.006)	0.70 (.028)	Solder Wave or Solder Reflow
0805	2012	2.00 (.079) ± 0.20 (.008)	1.25 (.049) ± 0.20 (.008)		0.50 (0.02) ± 0.25 (.010)	0.75 (.030)	
1206	3216	3.20 (.126) ± 0.20 (.008)	1.60 (.063) ± 0.20 (.008)		0.50 (0.02) ± 0.25 (.010)	N/A	Solder Reflow Only
1210	3225	3.20 (.126) ± 0.20 (.008)	2.50 (.098) ± 0.20 (.008)		0.50 (0.02) ± 0.25 (.010)		
1812	4532	4.50 (.177) ± 0.30 (.012)	3.20 (.126) ± 0.30 (.012)		0.60 (.024) ± 0.35 (.014)		

Applications

Typical applications include circuits with a direct battery or power source connection, critical and safety relevant circuits without (integrated) current limitation and any application that is subject to high levels of board flexure or temperature cycling. Examples include raw power input side filtering (power plane/bus), high current applications (automobile battery line) and circuits that cannot be fused to open. Markets include consumer, medical, industrial (power supply), automotive, aerospace and telecom.

Qualification/Certification

Commercial grade products are subject to internal qualification. Details regarding test methods and conditions are referenced in Table 4, Performance and Reliability.

Automotive grade products meet or exceed the requirements outlined by the Automotive Electronics Council. Details regarding test methods and conditions are referenced in document AEC-Q200, Stress Test Qualification for Passive Components. For additional information regarding the Automotive Electronics Council and AEC-Q200, please visit their website @www.aecouncil.com.

Environmental Compliance

Pb-Free and RoHS compliant (excluding SnPb termination finish option)

Electrical Parameters/Characteristics

Item	Parameters/Characteristics
Operating Temperature Range	-55°C to +125°C
Capacitance Change with Reference to +25°C and 0 Vdc Applied (TCC)	±15%
Aging Rate (Max % Cap Loss/Decade Hour)	3.0%
Dielectric Withstanding Voltage	250% of rated voltage (5 ± 1 seconds and charge/discharge not exceeding 50mA)
Dissipation Factor (DF) Maximum Limits @ 25°C	5%(10V), 3.5%(16V & 25V) and 2.5%(50V to 250V)
Insulation Resistance (IR) Limit @ 25°C	See Insulation Resistance Limit Table (Rated voltage applied for 120 ± 5 secs @ 25°C)

Regarding Aging Rate: Capacitance measurements (including tolerance) are indexed to a referee time of 1000 Hours.

To obtain IR limit, divide $M\Omega \cdot \mu F$ value by the capacitance and compare to $G\Omega$ limit. Select the lower of the two limits.

Capacitance and Dissipation Factor (DF) measured under the following conditions:

1kHz ± 50Hz and 1.0 ± 0.2 Vrms if capacitance ≤ 10μF

120Hz ± 10Hz and 0.5 ± 0.1 Vrms if capacitance > 10μF

Note: When measuring capacitance it is important to ensure the set voltage level is held constant. The HP4284 & Agilent E4980 have a feature known as Automatic Level Control (ALC). The ALC feature should be switched to "ON".

Post Environmental Limits

High Temperature Life, Biased Humidity, Moisture Resistance					
Dielectric	Rated DC Voltage	Capacitance Value	DF (%)	Cap Shift	IR
X7R	>25	All	3.0	± 20%	10% of Initial Limit
	16 / 25		5.0		
	< 16		7.5		

Insulation Resistance Limit Table

EIA Case Size	1000 megohm microfarads or 100GΩ	500 megohm microfarads or 10GΩ
0201	N/A	ALL
0402	< .012μF	≥ .012μF
0603	< .047μF	≥ .047μF
0805	< .047μF	≥ .047μF
1206	< 0.22μF	≥ 0.22μF
1210	< 0.39μF	≥ 0.39μF
1808	ALL	N/A
1812	< 2.2μF	≥ 2.2μF
1825	ALL	N/A
2220	< 10μF	≥ 10μF
2225	ALL	N/A

Table 1A – (FE-CAP), X7R Dielectric, (0402 - 0805 Case Sizes)

Cap	Cap Code	Series			C0402S					C0603S						C0805S								
		Voltage Code			9	8	4	3	5	9	8	4	3	5	1	2	9	8	4	3	5	1	2	A
		Voltage DC			6.3	10	16	25	50	6.3	10	16	25	50	100	200	6.3	10	16	25	50	100	200	250
		Cap Tolerance			Product Availability and Chip Thickness Codes - See Table 2 for Chip Thickness Dimensions																			
150 pF	151	J	K	M	BB	BB	BB	BB	BB	CB	CB	CB	CB	CB	CB	CB	DC	DC	DC	DC	DC	DC	DC	DC
180 pF	181	J	K	M	BB	BB	BB	BB	BB	CB	CB	CB	CB	CB	CB	CB	DC	DC	DC	DC	DC	DC	DC	DC
220 pF	221	J	K	M	BB	BB	BB	BB	BB	CB	CB	CB	CB	CB	CB	CB	DC	DC	DC	DC	DC	DC	DC	DC
270 pF	271	J	K	M	BB	BB	BB	BB	BB	CB	CB	CB	CB	CB	CB	CB	DC	DC	DC	DC	DC	DC	DC	DC
330 pF	331	J	K	M	BB	BB	BB	BB	BB	CB	CB	CB	CB	CB	CB	CB	DC	DC	DC	DC	DC	DC	DC	DC
390 pF	391	J	K	M	BB	BB	BB	BB	BB	CB	CB	CB	CB	CB	CB	CB	DC	DC	DC	DC	DC	DC	DC	DC
470 pF	471	J	K	M	BB	BB	BB	BB	BB	CB	CB	CB	CB	CB	CB	CB	DC	DC	DC	DC	DC	DC	DC	DC
560 pF	561	J	K	M	BB	BB	BB	BB	BB	CB	CB	CB	CB	CB	CB	CB	DC	DC	DC	DC	DC	DC	DC	DC
680 pF	681	J	K	M	BB	BB	BB	BB	BB	CB	CB	CB	CB	CB	CB	CB	DC	DC	DC	DC	DC	DC	DC	DC
820 pF	821	J	K	M	BB	BB	BB	BB	BB	CB	CB	CB	CB	CB	CB	CB	DC	DC	DC	DC	DC	DC	DC	DC
1,000 pF	102	J	K	M	BB	BB	BB	BB	BB	CB	CB	CB	CB	CB	CB	CB	DC	DC	DC	DC	DC	DC	DC	DC
1,200 pF	122	J	K	M						CB	CB	CB	CB	CB	CB	CB	DC	DC	DC	DC	DC	DC	DC	DC
1,500 pF	152	J	K	M						CB	CB	CB	CB	CB	CB	CB	DC	DC	DC	DC	DC	DC	DC	DC
1,800 pF	182	J	K	M						CB	CB	CB	CB	CB	CB	CB	DC	DC	DC	DC	DC	DC	DC	DC
2,200 pF	222	J	K	M						CB	CB	CB	CB	CB	CB	CB	DC	DC	DC	DC	DC	DC	DC	DC
2,700 pF	272	J	K	M						CB	CB	CB	CB	CB	CB	CB	DC	DC	DC	DC	DC	DC	DC	DC
3,300 pF	332	J	K	M						CB	CB	CB	CB	CB	CB	CB	DC	DC	DC	DC	DC	DC	DC	DC
3,900 pF	392	J	K	M						CB	CB	CB	CB	CB	CB	CB	DC	DC	DC	DC	DC	DC	DC	DC
4,700 pF	472	J	K	M						CB	CB	CB	CB	CB	CB	CB	DC	DC	DC	DC	DC	DC	DC	DC
5,600 pF	562	J	K	M						CB	CB	CB	CB	CB	CB	CB	DC	DC	DC	DC	DC	DC	DC	DC
6,800 pF	682	J	K	M						CB	CB	CB	CB	CB	CB	CB	DC	DC	DC	DC	DC	DC	DC	DC
8,200 pF	822	J	K	M						CB	CB	CB	CB	CB	CB	CB	DC	DC	DC	DC	DC	DC	DC	DC
10,000 pF	103	J	K	M						CB	CB	CB	CB	CB	CB	CB	DC	DC	DC	DC	DC	DC	DC	DC
12,000 pF	123	J	K	M						CB	CB	CB	CB	CB	CB	CB	DC	DC	DC	DC	DC	DC	DC	DC
15,000 pF	153	J	K	M						CB	CB	CB	CB	CB	CB	CB	DC	DC	DC	DC	DC	DC	DC	DC
18,000 pF	183	J	K	M						CB	CB	CB	CB	CB	CB	CB	DC	DC	DC	DC	DC	DC	DD	
22,000 pF	223	J	K	M						CB	CB	CB	CB	CB	CB	CB	DC	DC	DC	DC	DC	DC	DD	
27,000 pF	273	J	K	M													DC	DC	DC	DC	DC	DC		
33,000 pF	333	J	K	M													DC	DC	DC	DC	DC	DC		
39,000 pF	393	J	K	M													DC	DC	DC	DC	DC	DC		
47,000 pF	473	J	K	M													DC	DC	DC	DC	DC	DC		
56,000 pF	563	J	K	M													DD	DD	DD	DD	DD	DD		
68,000 pF	683	J	K	M													DD	DD	DD	DD	DD	DD		
82,000 pF	823	J	K	M													DG	DG	DG	DG	DG	DG		
0.10 µF	104	J	K	M													DG	DG	DG	DG	DG	DG		
Cap	Cap Code	Voltage DC			6.3	10	16	25	50	6.3	10	16	25	50	100	200	6.3	10	16	25	50	100	200	250
		Voltage Code			9	8	4	3	5	9	8	4	3	5	1	2	9	8	4	3	5	1	2	A
		Series			C0402S					C0603S						C0805S								

Flexible Termination System (FT-CAP) X7R Dielectric, 6.3VDC-250VDC (Commercial Grade & Automotive Grade)

Overview

KEMET's Flexible Termination (FT-CAP) multilayer ceramic capacitor in X7R dielectric incorporates a unique, flexible termination system that is integrated with KEMET's standard termination materials. A conductive silver epoxy is utilized between the base metal and nickel barrier layers of KEMET's standard termination system in order to establish pliability while maintaining terminal strength, solderability and electrical performance. This technology was developed in order to address the primary failure mode of MLCCs—flex cracks, which are typically the result of excessive shear stresses produced during board flexure or thermal cycling. Flexible termination technology directs board flex stress away from the ceramic body and into the termination area, therefore mitigating flex cracks which can result in low IR or short circuit failures.

Although this technology does not eliminate the potential for mechanical damage that may propagate during extreme environmental and handling conditions, it does provide

superior flex performance over standard termination systems. Manufactured in state of the art ISO/TS 16949:2002 certified facilities, the FT-CAP complements KEMET's Open Mode, Floating Electrode (FE-CAP), Floating Electrode with Flexible Termination (FF-CAP) and KEMET Power Solutions (KPS) product lines by providing a complete portfolio of flex mitigation solutions.

Combined with the stability of an X7R dielectric and designed to accommodate all capacitance requirements, these flex-robust devices are RoHS-compliant, offer up to 5mm of flex-bend capability and exhibit a predictable change in capacitance with respect to time and voltage. Capacitance change with reference to ambient temperature is limited to $\pm 15\%$ from -55°C to $+125^{\circ}\text{C}$.

In addition to commercial grade, automotive grade devices are available which meet the demanding Automotive Electronics Council's AEC-Q200 qualification requirements .

Benefits

- -55°C to $+125^{\circ}\text{C}$ operating temperature range
- Superior flex performance (up to 5mm)
- High capacitance flex mitigation
- Pb-Free and RoHS compliant
- EIA 0603, 0805, 1206, 1210, 1808, 1812, 2220 and 2225 case sizes
- DC voltage ratings of 6.3V, 10V, 16V, 25V, 50V, 100V, 200V and 250V
- Capacitance offerings ranging from 180pF to 22 μF
- Available capacitance tolerances of $\pm 5\%$, $\pm 10\%$ and $\pm 20\%$

- Non-polar device, minimizing installation concerns
- 100% pure matte tin-plated termination finish allowing for excellent solderability
- SnPb termination finish option available upon request (5% min)
- Commercial and Automotive (AEC-Q200) grades available

**FLEXIBLE
 FT-CAP
 TERMINATION**

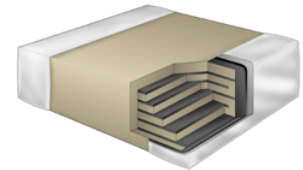

Ordering Information

C	1206	X	106	K	4	R	A	C	AUTO
Ceramic	Case Size (L" x W")	Specification/ Series	Capacitance Code (pF)	Capacitance Tolerance	Voltage	Dielectric	Failure Rate/ Design	Termination Finish ¹	Packaging/Grade (C-Spec) ²
	0603 0805 1206 1210 1808 1812 1825 2220 2225	X = Flexible Termination	2 Sig. Digits + Number of Zeros	J = $\pm 5\%$ K = $\pm 10\%$ M = $\pm 20\%$	9 = 6.3V 8 = 10V 4 = 16V 3 = 25V 5 = 50V 1 = 100V 2 = 200V A = 250V	R = X7R	A = N/A	C = 100% Matte Sn L = SnPb (5% min)	Blank = Bulk TU = 7" Reel Unmarked TM = 7" Reel Marked AUTO = Automotive Grade 7" Reel Unmarked

¹ Additional termination finish options may be available. Contact KEMET for details.

² Additional reeling or packaging options may be available. Contact KEMET for details.

Dimensions – Millimeters (Inches)

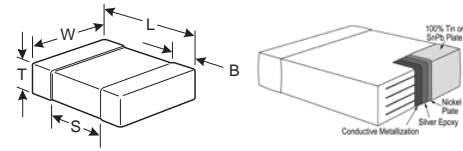

EIA Size Code	Metric Size Code	L Length	W Width	T Thickness	B Bandwidth	S Separation Min.	Mounting Technique
0603	1608	1.60 (.063) +0.20 (.008) / -0.10 (.004)	0.80 (.032) ± 0.15 (.006)	See Table 2 for Thickness	0.45 (.018) +0.05 (.002) / -0.15 (.006)	0.50 (.020)	Solder Wave or Solder Reflow
0805	2012	2.10 (.083) +0.30 (.012) / -0.20 (.008)	1.25 (.049) ± 0.20 (.008)		0.50 (0.02) +0.10(.004) / -0.25 (.010)	0.70 (.028)	
1206	3216	3.30 (.130) ± 0.40 (.016)	1.60 (.063) ± 0.20 (.008)		0.60 (.024) ± 0.25 (.010)	N/A	Solder Reflow Only
1210	3225	3.30 (.130) ± 0.40 (.016)	2.50 (.098) ± 0.20 (.008)		0.60 (.024) ± 0.25 (.010)		
1808	4520	4.70 (.185) ± 0.50 (.020)	2.00 (.079) ± 0.20 (.008)		0.70 (.028) ± 0.35 (.014)		
1812	4532	4.50 (.178) ± 0.40 (.016)	3.20 (.126) ± 0.30 (.012)		0.70 (.028) ± 0.35 (.014)		
1825	4564	4.60 (.181) ± 0.40 (.016)	6.40 (.252) ± 0.40 (.016)		0.70 (.028) ± 0.35 (.014)		
2220	5650	5.90 (.232) ± 0.75 (.030)	5.00 (.197) ± 0.40 (.016)		0.70 (.028) ± 0.35 (.014)		
2225	5664	5.90 (.232) ± 0.75 (.030)	6.40 (.248) ± 0.40 (.016)		0.70 (.028) ± 0.35 (.014)		

Applications

Typical applications include circuits with a direct battery or power source connection, critical and safety relevant circuits without (integrated) current limitation and any application that is subject to high levels of board flexure or temperature cycling. Examples include raw power input side filtering (power plane/bus), high current applications (automobile battery line) and circuits that cannot be fused to open. Markets include consumer, medical, industrial (power supply), automotive, aerospace and telecom.

Qualification/Certification

Commercial grade products are subject to internal qualification. Details regarding test methods and conditions are referenced in Table 4, Performance and Reliability.

Automotive grade products meet or exceed the requirements outlined by the Automotive Electronics Council. Details regarding test methods and conditions are referenced in document AEC-Q200, Stress Test Qualification for Passive Components. For additional information regarding the Automotive Electronics Council and AEC-Q200, please visit their website @www.aecouncil.com.

Environmental Compliance

Pb-Free and RoHS compliant (excluding SnPb termination finish option)

Electrical Parameters/Characteristics

Item	Parameters/Characteristics
Operating Temperature Range	-55°C to +125°C
Capacitance Change with Reference to +25°C and 0 Vdc Applied (TCC)	±15%
Aging Rate (Max % Cap Loss/Decade Hour)	3.0%
Dielectric Withstanding Voltage	250% of rated voltage (5 ± 1 seconds and charge/discharge not exceeding 50mA)
Dissipation Factor (DF) Maximum Limits @ 25°C	5%(10V), 3.5%(16V & 25V) and 2.5%(50V to 250V)
Insulation Resistance (IR) Limit @ 25°C	See Insulation Resistance Limit Table (Rated voltage applied for 120 ± 5 secs @ 25°C)

Regarding Aging Rate: Capacitance measurements (including tolerance) are indexed to a referee time of 1000 hours.

To obtain IR limit, divide $M\Omega\text{-}\mu\text{F}$ value by the capacitance and compare to $G\Omega$ limit. Select the lower of the two limits.

Capacitance and Dissipation Factor (DF) measured under the following conditions:

1kHz ± 50Hz and 1.0 ± 0.2 Vrms if capacitance ≤ 10μF

120Hz ± 10Hz and 0.5 ± 0.1 Vrms if capacitance > 10μF

Note: When measuring capacitance it is important to ensure the set voltage level is held constant. The HP4284 & Agilent E4980 have a feature known as Automatic Level Control (ALC). The ALC feature should be switched to "ON".

Post Environmental Limits

High Temperature Life, Biased Humidity, Moisture Resistance					
Dielectric	Rated DC Voltage	Capacitance Value	DF (%)	Cap Shift	IR
X7R	>25	All	3.0	± 20%	10% of Initial Limit
	16 / 25		5.0		
	< 16		7.5		

Insulation Resistance Limit Table

EIA Case Size	1000 megohm microfarads or 100GΩ	500 megohm microfarads or 10GΩ
0201	N/A	ALL
0402	< .012μF	≥ .012μF
0603	< .047μF	≥ .047μF
0805	< .047μF	≥ .047μF
1206	< 0.22μF	≥ 0.22μF
1210	< 0.39μF	≥ 0.39μF
1808	ALL	N/A
1812	< 2.2μF	≥ 2.2μF
1825	ALL	N/A
2220	< 10μF	≥ 10μF
2225	ALL	N/A

Table 1B – (FT-CAP), X7R Dielectric, (1808 - 2225 Case Sizes) con't

Cap	Cap Code	Series	C1808X				C1812X				C1825X				C2220X					C2225X								
		Voltage Code	5	1	2	A	3	5	1	2	A	5	1	2	A	3	5	1	2	A	5	1	2	A				
		Voltage DC	50	100	200	250	25	50	100	200	250	50	100	200	250	25	50	100	200	250	50	100	200	250				
		Cap Tolerance	Product Availability and Chip Thickness Codes - See Table 2 for Chip Thickness Dimensions																									
1.5 µF	155	J	K	M											HC					JC	JC				KC			
1.8 µF	185	J	K	M											HD					JD	JD				KD			
2.2 µF	225	J	K	M											HF					JF	JF				KD			
2.7 µF	275	J	K	M																								
3.3 µF	335	J	K	M																								
3.9 µF	395	J	K	M																								
4.7 µF	475	J	K	M				GK	GK																			
5.6 µF	565	J	K	M																								
6.8 µF	685	J	K	M																								
8.2 µF	825	J	K	M																								
10 µF	106	J	K	M				GK												JF	JO							
12 µF	126	J	K	M																								
15 µF	156	J	K	M																JO								
18 µF	186	J	K	M																JO								
22 µF	226	J	K	M																JO								
Cap	Cap Code	Voltage DC	50	100	200	250	25	50	100	200	250	50	100	200	250	25	50	100	200	250	50	100	200	250				
		Voltage Code	5	1	2	A	3	5	1	2	A	5	1	2	A	3	5	1	2	A	5	1	2	A				
		Series	C1808X				C1812X				C1825X				C2220X					C2225X								

Floating Electrode Design with Flexible Termination System (FF-CAP) X7R Dielectric, 6.3VDC-250VDC (Commercial Grade)

Overview

KEMET's Floating Electrode with Flexible Termination capacitor (FF-CAP) combines two existing KEMET technologies— Floating Electrode and Flexible Termination. The floating electrode component utilizes a cascading internal electrode design configured to form multiple capacitors in series within a single monolithic structure. This unique configuration results in enhanced voltage and ESD performance over standard capacitor designs while allowing for a fail-open condition if mechanically damaged (cracked). The flexible termination component utilizes a conductive silver epoxy between the base metal and nickel barrier layers of KEMET's standard termination system in order to establish pliability while maintaining terminal strength, solderability and electrical performance. Both technologies address the primary failure mode of MLCCs—flex cracks, which are typically the result of excessive shear stresses produced during board

flexure or thermal cycling.

Although neither technology can eliminate the potential for mechanical damage that may propagate during extreme environmental and/or handling conditions, the combination of these two technologies provide the ultimate level of protection against a low IR or short circuit condition. The FF-CAP complements KEMET's Open Mode, Floating Electrode (FE-CAP), Flexible Termination (FT-CAP) and KEMET Power Solutions (KPS) product lines by providing an ultimate fail-safe design optimized for low to mid range capacitance values. These devices exhibit a predictable change in capacitance with respect to time and voltage and boast a minimal change in capacitance with reference to ambient temperature. Capacitance change is limited to $\pm 15\%$ from -55°C to $+125^{\circ}\text{C}$.

Benefits

- -55°C to $+125^{\circ}\text{C}$ operating temperature range
- Superior flex performance (up to 5mm)
- Floating Electrode/fail open design
- Low to mid capacitance flex mitigation
- Pb-Free and RoHS compliant
- EIA 0603, 0805, 1206, 1210, and 1812 case sizes
- DC voltage ratings of 6.3V, 10V, 16V, 25V, 50V, 100V, 200V and 250V
- Capacitance offerings ranging from 180pF to 0.22 μF
- Available capacitance tolerances of $\pm 5\%$, $\pm 10\%$ and $\pm 20\%$
- Non-polar device, minimizing installation concerns
- 100% pure matte tin-plated termination finish allowing for excellent solderability
- SnPb termination finish option available upon request (5% min)

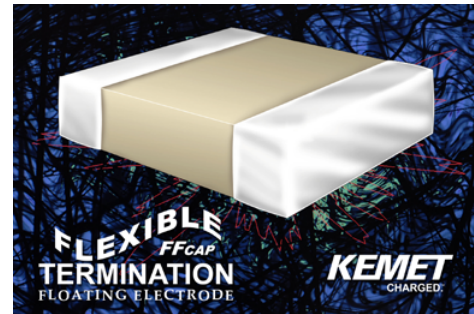

Ordering Information

C	0805	Y	104	K	5	R	A	C	TU
Ceramic	Case Size (L" x W")	Specification/ Series	Capacitance Code (pF)	Capacitance Tolerance	Voltage	Dielectric	Failure Rate/ Design	Termination Finish ¹	Packaging/Grade (C-Spec) ²
	0603 0805 1206 1210 1812	Y = Floating Electrode w/ Flexible Termination	2 Sig. Digits + Number of Zeros	J = $\pm 5\%$ K = $\pm 10\%$ M = $\pm 20\%$	9 = 6.3V 8 = 10V 4 = 16V 3 = 25V 5 = 50V 1 = 100V 2 = 200V A = 250V	R = X7R	A = N/A	C = 100% Matte Sn L = SnPb (5% min)	Blank = Bulk TU = 7" Reel Unmarked TM = 7" Reel Marked

¹ Additional termination finish options may be available. Contact KEMET for details.

² Additional reeling or packaging options may be available. Contact KEMET for details.

Dimensions – Millimeters (Inches)

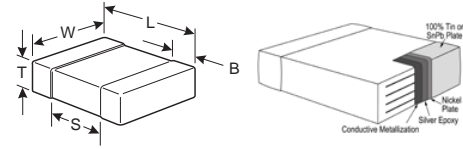

EIA Size Code	Metric Size Code	L Length	W Width	T Thickness	B Bandwidth	S Separation Min.	Mounting Technique
0603	1608	1.60 (.063) +0.20 (.008) / -0.10 (.004)	0.80 (.032) ± 0.15 (.006)	See Table 2 for Thickness	0.45 (.018) +0.05 (.002) / -0.15 (.006)	0.50 (.020)	Solder Wave or Solder Reflow
0805	2012	2.10 (.083) +0.30 (.012) / -0.20 (.008)	1.25 (.049) ± 0.20 (.008)		0.50 (0.02) +0.10(.004) / -0.25 (.010)	0.70 (.028)	
1206	3216	3.20 (.126) ± 0.20 (.008)	1.60 (.063) ± 0.20 (.008)		0.50 (0.02) ± 0.25 (.010)	N/A	Solder Reflow Only
1210	3225	3.20 (.126) ± 0.20 (.008)	2.50 (.098) ± 0.20 (.008)		0.50 (0.02) ± 0.25 (.010)		
1812	4532	4.50 (.177) ± 0.30 (.012)	3.20 (.126) ± 0.30 (.012)		0.60 (.024) ± 0.35 (.014)		

Applications

Typical applications include circuits with a direct battery or power source connection, critical and safety relevant circuits without (integrated) current limitation and any application that is subject to high levels of board flexure or temperature cycling. Examples include raw power input side filtering (power plane/bus), high current applications (automobile battery line) and circuits that cannot be fused to open. Markets include consumer, medical, industrial (power supply), automotive, aerospace and telecom.

Qualification/Certification

Commercial grade products are subject to internal qualification. Details regarding test methods and conditions are referenced in Table 4, Performance and Reliability.

Automotive grade products meet or exceed the requirements outlined by the Automotive Electronics Council. Details regarding test methods and conditions are referenced in document AEC-Q200, Stress Test Qualification for Passive Components. For additional information regarding the Automotive Electronics Council and AEC-Q200, please visit their website @www.aecouncil.com.

Environmental Compliance

Pb-Free and RoHS compliant (excluding SnPb termination finish option)

Electrical Parameters/Characteristics

Item	Parameters/Characteristics
Operating Temperature Range	-55°C to +125°C
Capacitance Change with Reference to +25°C and 0 Vdc Applied (TCC)	±15%
Aging Rate (Max % Cap Loss/Decade Hour)	3.0%
Dielectric Withstanding Voltage	250% of rated voltage (5 ± 1 seconds and charge/discharge not exceeding 50mA)
Dissipation Factor (DF) Maximum Limits @ 25°C	5%(10V), 3.5%(16V & 25V) and 2.5%(50V to 250V)
Insulation Resistance (IR) Limit @ 25°C	See Insulation Resistance Limit Table (Rated voltage applied for 120 ± 5 secs @ 25°C)

Regarding Aging Rate: Capacitance measurements (including tolerance) are indexed to a referee time of 1000 Hours.

To obtain IR limit, divide $M\Omega\text{-}\mu\text{F}$ value by the capacitance and compare to $G\Omega$ limit. Select the lower of the two limits.

Capacitance and Dissipation Factor (DF) measured under the following conditions:

1kHz ± 50Hz and 1.0 ± 0.2 Vrms if capacitance ≤ 10μF

120Hz ± 10Hz and 0.5 ± 0.1 Vrms if capacitance > 10μF

Note: When measuring capacitance it is important to ensure the set voltage level is held constant. The HP4284 & Agilent E4980 have a feature known as Automatic Level Control (ALC). The ALC feature should be switched to "ON".

Post Environmental Limits

High Temperature Life, Biased Humidity, Moisture Resistance					
Dielectric	Rated DC Voltage	Capacitance Value	DF (%)	Cap Shift	IR
X7R	>25	All	3.0	± 20%	10% of Initial Limit
	16 / 25		5.0		
	< 16		7.5		

Insulation Resistance Limit Table

EIA Case Size	1000 megohm microfarads or 100GΩ	500 megohm microfarads or 10GΩ
0201	N/A	ALL
0402	< .012μF	≥ .012μF
0603	< .047μF	≥ .047μF
0805	< .047μF	≥ .047μF
1206	< 0.22μF	≥ 0.22μF
1210	< 0.39μF	≥ 0.39μF
1808	ALL	N/A
1812	< 2.2μF	≥ 2.2μF
1825	ALL	N/A
2220	< 10μF	≥ 10μF
2225	ALL	N/A

Table 1A – (FF-CAP), X7R Dielectric, (0603 - 0805 Case Sizes)

Cap	Cap Code	Series			C0603Y							C0805Y							
		Voltage Code			9	8	4	3	5	1	2	9	8	4	3	5	1	2	A
		Voltage DC			6.3	10	16	25	50	100	200	6.3	10	16	25	50	100	200	250
		Cap Tolerance			Product Availability and Chip Thickness Codes - See Table 2 for Chip Thickness Dimensions														
150 pF	151	J	K	M															
180 pF	181	J	K	M	CB	CB	CB	CB	CB	CB	CB	DC	DC	DC	DC	DC	DC	DC	
220 pF	221	J	K	M	CB	CB	CB	CB	CB	CB	CB	DC	DC	DC	DC	DC	DC	DC	
270 pF	271	J	K	M	CB	CB	CB	CB	CB	CB	CB	DC	DC	DC	DC	DC	DC	DC	
330 pF	331	J	K	M	CB	CB	CB	CB	CB	CB	CB	DC	DC	DC	DC	DC	DC	DC	
390 pF	391	J	K	M	CB	CB	CB	CB	CB	CB	CB	DC	DC	DC	DC	DC	DC	DC	
470 pF	471	J	K	M	CB	CB	CB	CB	CB	CB	CB	DC	DC	DC	DC	DC	DC	DC	
560 pF	561	J	K	M	CB	CB	CB	CB	CB	CB	CB	DC	DC	DC	DC	DC	DC	DC	
680 pF	681	J	K	M	CB	CB	CB	CB	CB	CB	CB	DC	DC	DC	DC	DC	DC	DC	
820 pF	821	J	K	M	CB	CB	CB	CB	CB	CB	CB	DC	DC	DC	DC	DC	DC	DC	
1,000 pF	102	J	K	M	CB	CB	CB	CB	CB	CB	CB	DC	DC	DC	DC	DC	DC	DC	
1,200 pF	122	J	K	M	CB	CB	CB	CB	CB	CB	CB	DC	DC	DC	DC	DC	DC	DC	
1,500 pF	152	J	K	M	CB	CB	CB	CB	CB	CB	CB	DC	DC	DC	DC	DC	DC	DC	
1,800 pF	182	J	K	M	CB	CB	CB	CB	CB	CB	CB	DC	DC	DC	DC	DC	DC	DC	
2,200 pF	222	J	K	M	CB	CB	CB	CB	CB	CB	CB	DC	DC	DC	DC	DC	DC	DC	
2,700 pF	272	J	K	M	CB	CB	CB	CB	CB	CB	CB	DC	DC	DC	DC	DC	DC	DC	
3,300 pF	332	J	K	M	CB	CB	CB	CB	CB	CB	CB	DC	DC	DC	DC	DC	DC	DC	
3,900 pF	392	J	K	M	CB	CB	CB	CB	CB	CB	CB	DC	DC	DC	DC	DC	DC	DC	
4,700 pF	472	J	K	M	CB	CB	CB	CB	CB	CB	CB	DC	DC	DC	DC	DC	DC	DC	
5,600 pF	562	J	K	M	CB	CB	CB	CB	CB	CB	CB	DC	DC	DC	DC	DC	DC	DC	
6,800 pF	682	J	K	M	CB	CB	CB	CB	CB	CB	CB	DC	DC	DC	DC	DC	DC	DC	
8,200 pF	822	J	K	M	CB	CB	CB	CB	CB	CB	CB	DC	DC	DC	DC	DC	DC	DC	
10,000 pF	103	J	K	M	CB	CB	CB	CB	CB	CB	CB	DC	DC	DC	DC	DC	DC	DC	
12,000 pF	123	J	K	M	CB	CB	CB	CB	CB	CB	CB	DC	DC	DC	DC	DC	DC	DC	
15,000 pF	153	J	K	M	CB	CB	CB	CB	CB	CB	CB	DC	DC	DC	DC	DC	DC	DC	
18,000 pF	183	J	K	M	CB	CB	CB	CB	CB	CB	CB	DC	DC	DC	DC	DC	DD		
22,000 pF	223	J	K	M	CB	CB	CB	CB	CB	CB	CB	DC	DC	DC	DC	DC	DD		
27,000 pF	273	J	K	M								DC	DC	DC	DC	DC			
33,000 pF	333	J	K	M								DC	DC	DC	DC	DC			
39,000 pF	393	J	K	M								DC	DC	DC	DC	DC			
47,000 pF	473	J	K	M								DC	DC	DC	DC	DC			
56,000 pF	563	J	K	M								DD	DD	DD	DD	DD			
68,000 pF	683	J	K	M								DD	DD	DD	DD	DD			
82,000 pF	823	J	K	M								DG	DG	DG	DG	DG			
0.10 µF	104	J	K	M								DG	DG	DG	DG	DG			
Cap	Cap Code	Voltage DC			6.3	10	16	25	50	100	200	6.3	10	16	25	50	100	200	250
		Voltage Code			9	8	4	3	5	1	2	9	8	4	3	5	1	2	A
		Series			C0603Y							C0805Y							

Table 1B – (FF-CAP), X7R Dielectric, (1206 - 1812 Case Sizes)

Cap	Cap Code	Series			C1206Y								C1210Y								C1812Y																										
		Voltage Code			9	8	4	3	5	1	2	A	9	8	4	3	5	1	2	A	9	8	4	3	5																						
		Voltage DC			6.3	10	16	25	50	100	200	250	6.3	10	16	25	50	100	200	250	6.3	10	16	25	50																						
Cap Tolerance		Product Availability and Chip Thickness Codes - See Table 2 for Chip Thickness Dimensions																																													
1,000 pF	102	J	K	M	EB	EB	EB	EB	EB	EB	EB	EB	EB	EB	EB	EB	EB	EB																													
1,200 pF	122	J	K	M	EB	EB	EB	EB	EB	EB	EB	EB	EB	EB	EB	EB	EB	EB																													
1,500 pF	152	J	K	M	EB	EB	EB	EB	EB	EB	EB	EB	EB	EB	EB	EB	EB	EB																													
1,800 pF	182	J	K	M	EB	EB	EB	EB	EB	EB	EB	EB	EB	EB	EB	EB	EB	EB																													
2,200 pF	222	J	K	M	EB	EB	EB	EB	EB	EB	EB	EB	EB	EB	EB	EB	EB	EB	FB	FB	FB	FB	FB	FB	FB	FB	FB	FB	FB	FB	FB	FB	FB	FB	FB												
2,700 pF	272	J	K	M	EB	EB	EB	EB	EB	EB	EB	EB	EB	EB	EB	EB	EB	EB	FB	FB	FB	FB	FB	FB	FB	FB	FB	FB	FB	FB	FB	FB	FB	FB	FB												
3,300 pF	332	J	K	M	EB	EB	EB	EB	EB	EB	EB	EB	EB	EB	EB	EB	EB	EB	FB	FB	FB	FB	FB	FB	FB	FB	FB	FB	FB	FB	FB	FB	FB	FB	FB												
3,900 pF	392	J	K	M	EB	EB	EB	EB	EB	EB	EB	EB	EB	EB	EB	EB	EB	EB	FB	FB	FB	FB	FB	FB	FB	FB	FB	FB	FB	FB	FB	FB	FB	FB	FB												
4,700 pF	472	J	K	M	EB	EB	EB	EB	EB	EB	EB	EB	EB	EB	EB	EB	EB	EB	FB	FB	FB	FB	FB	FB	FB	FB	FB	FB	FB	FB	FB	FB	FB	FB	FB												
5,600 pF	562	J	K	M	EB	EB	EB	EB	EB	EB	EB	EB	EB	EB	EB	EB	EB	EB	FB	FB	FB	FB	FB	FB	FB	FB	FB	FB	FB	FB	FB	FB	FB	FB	FB												
6,800 pF	682	J	K	M	EB	EB	EB	EB	EB	EB	EB	EB	EB	EB	EB	EB	EB	EB	FB	FB	FB	FB	FB	FB	FB	FB	FB	FB	FB	FB	FB	FB	FB	FB	GB	GB											
8,200 pF	822	J	K	M	EB	EB	EB	EB	EB	EB	EB	EB	EB	EB	EB	EB	EB	EB	FB	FB	FB	FB	FB	FB	FB	FB	FB	FB	FB	FB	FB	FB	FB	GB	GB												
10,000 pF	103	J	K	M	EB	EB	EB	EB	EB	EB	EB	EB	EB	EB	EB	EB	EB	EB	FB	FB	FB	FB	FB	FB	FB	FB	FB	FB	FB	FB	FB	FB	FB	GB	GB												
12,000 pF	123	J	K	M	EB	EB	EB	EB	EB	EB	EB	EB	EB	EB	EB	EB	EB	EB	FB	FB	FB	FB	FB	FB	FB	FB	FB	FB	FB	FB	FB	FB	FB	GB	GB												
15,000 pF	153	J	K	M	EB	EB	EB	EB	EB	EB	EB	EB	EB	EB	EB	EB	EB	EB	FB	FB	FB	FB	FB	FB	FB	FB	FB	FB	FB	FB	FB	FB	FB	GB	GB												
18,000 pF	183	J	K	M	EB	EB	EB	EB	EB	EB	EB	EB	EB	EB	EB	EB	EB	EB	FB	FB	FB	FB	FB	FB	FB	FB	FB	FB	FB	FB	FB	FB	FB	GB	GB												
22,000 pF	223	J	K	M	EB	EB	EB	EB	EB	EB	EB	EB	EB	EB	EB	EB	EB	EB	FB	FB	FB	FB	FB	FB	FB	FB	FB	FB	FB	FB	FB	FB	FB	GB	GB												
27,000 pF	273	J	K	M	EB	EB	EB	EB	EB	EB	EB	EB	EB	EB	EB	EB	EB	EB	FB	FB	FB	FB	FB	FB	FB	FB	FB	FB	FB	FB	FB	FB	FB	GB	GB												
33,000 pF	333	J	K	M	EB	EB	EB	EB	EB	EB	EB	EB	EB	EB	EB	EB	EB	EB	FB	FB	FB	FB	FB	FB	FB	FB	FB	FB	FB	FB	FB	FB	FB	GB	GB												
39,000 pF	393	J	K	M	EB	EB	EB	EB	EB	EB	EB	EB	EB	EB	EB	EB	EB	EB	FB	FB	FB	FB	FB	FB	FB	FB	FB	FB	FB	FB	FB	FB	FB	GB	GB												
47,000 pF	473	J	K	M	EB	EB	EB	EB	EB	EB	EB	EB	EB	EB	EB	EB	EB	EB	FB	FB	FB	FB	FB	FB	FB	FB	FB	FB	FB	FC	FC	FC	GB	GB													
56,000 pF	563	J	K	M	EB	EB	EB	EB	EB	EB	EB	EB	EB	EB	EB	EB	EB	EB	FB	FB	FB	FB	FB	FB	FB	FB	FB	FB	FB	FC	FC	FC	GB	GB													
68,000 pF	683	J	K	M	EB	EB	EB	EB	EB	EB	EB	EB	EB	EB	EB	EB	EB	EB	FB	FB	FB	FB	FB	FB	FB	FB	FB	FB	FB	FB	FB	FB	FB	GB	GB												
82,000 pF	823	J	K	M	EB	EB	EB	EB	EB	EB	EB	EB	EB	EB	EB	EB	EB	EB	FB	FB	FB	FB	FB	FB	FB	FB	FB	FB	FB	FB	FB	FB	FB	GB	GB												
0.10 µF	104	J	K	M	EB	EB	EB	EB	EB	EB	EB	EB	EB	EB	EB	EB	EB	EB	FB	FB	FB	FB	FB	FB	FB	FB	FB	FB	FB	FB	FB	FB	FB	GB	GB												
0.12 µF	124	J	K	M	EC	EC	EC	EC	EC										FB	FB	FB	FB	FB	FB	FB	FB	FB	FB	FB	FB	FB	FB	FB	GB	GB												
0.15 µF	154	J	K	M															FC	FC	FC	FC	FC	FC	FC	FC	FC	FC	FC	FC	FC	FC	FC	GB	GB												
0.18 µF	184	J	K	M															FC	FC	FC	FC	FC	FC	FC	FC	FC	FC	FC	FC	FC	FC	FC	GB	GB												
0.22 µF	224	J	K	M															FC	FC	FC	FC	FC	FC	FC	FC	FC	FC	FC	FC	FC	FC	FC	GB	GB												
Cap	Cap Code	Voltage DC			6.3	10	16	25	50	100	200	250	Voltage Code			9	8	4	3	5	1	2	A	Series			C1206Y								C1210Y								C1812Y				

Surface Mount Multilayer Ceramic Chip Capacitors (SMD MLCCs)
KPS Series, X7R Dielectric, 10VDC-250VDC
(Commercial Grade)



Overview

KEMET Power Solutions (KPS) Commercial Series stacked capacitors utilize a proprietary lead-frame technology to vertically stack one or two multilayer ceramic chip capacitors into a single compact surface mount package. The attached lead-frame mechanically isolates the capacitor/s from the printed circuit board, therefore offering advanced mechanical and thermal stress performance. Isolation also addresses concerns for audible, microphonic noise that may occur when a bias voltage is applied. A two chip stack offers up to double the capacitance in the same or smaller design footprint when compared to traditional surface mount MLCC devices. Providing up to 10mm of board flex

capability, KPS Series capacitors are environmentally friendly and in compliance with RoHS legislation. Available in X7R dielectric, these devices are capable of Pb-Free reflow profiles and provide lower ESR, ESL and higher ripple current capability when compared to other dielectric solutions.

Combined with the stability of an X7R dielectric, KEMET's KPS Series devices exhibit a predictable change in capacitance with respect to time and voltage and boast a minimal change in capacitance with reference to ambient temperature. Capacitance change is limited to $\pm 15\%$ from -55°C to $+125^{\circ}\text{C}$.

Benefits

- -55°C to $+125^{\circ}\text{C}$ operating temperature range
- Reliable and robust termination system
- EIA 1210, 1812 and 2220 case sizes
- DC voltage ratings of 10V, 16V, 25V, 50V, 100V and 250V
- Capacitance offerings ranging from $0.1\mu\text{F}$ up to $47\mu\text{F}$
- Available capacitance tolerances of $\pm 10\%$ and $\pm 20\%$
- Higher capacitance in the same footprint
- Potential board space savings
- Advanced protection against thermal and mechanical stress
- Provides up to 10mm of board flex capability
- Reduces audible, microphonic noise
- Extremely low ESR and ESL
- Pb-Free and RoHS compliant
- Capable of Pb-Free reflow profiles
- Non-polar device, minimizing installation concerns
- Tantalum and electrolytic alternative

Applications

Typical applications include smoothing circuits, DC/DC converters, power supplies (input/output filters), noise reduction (piezoelectric/mechanical), circuits with a direct battery or power source connection, critical and safety relevant circuits without (integrated) current limitation and any application that is subject to high levels of board flexure or temperature cycling. Markets include industrial, military, automotive and telecom.

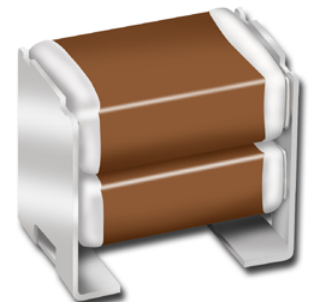

Ordering Information

C	1210	C	225	M	4	R	1	C	7186
Ceramic	Case Size (L" x W")	Specification/ Series	Capacitance Code (pF)	Capacitance Tolerance ¹	Voltage	Dielectric	Failure Rate/Design	Leadframe Finish ²	Packaging/Grade (C-Spec) ³
	1210 1812 2220	C = Standard	2 Sig. Digits + Number of Zeros	K = $\pm 10\%$ M = $\pm 20\%$	8 = 10V 4 = 16V 3 = 25V 5 = 50V 1 = 100V A = 250V	R = X7R	1 = KPS Single Chip Stack 2 = KPS Double Chip Stack	C = 100% Matte Sn	7186 = 7" Reel Unmarked 7289 = 13" Reel Unmarked

¹ Double chip stacks ("2" in the 13th character position of the ordering code) are only available in M ($\pm 20\%$) capacitance tolerance. Single chip stacks ("1" in the 13th character position of the ordering code) are available in K ($\pm 10\%$) or M ($\pm 20\%$) tolerances.

² Additional leadframe finish options may be available. Contact KEMET for details.

³ Additional reeling or packaging options may be available. Contact KEMET for details.

Dimensions – Millimeters (Inches)

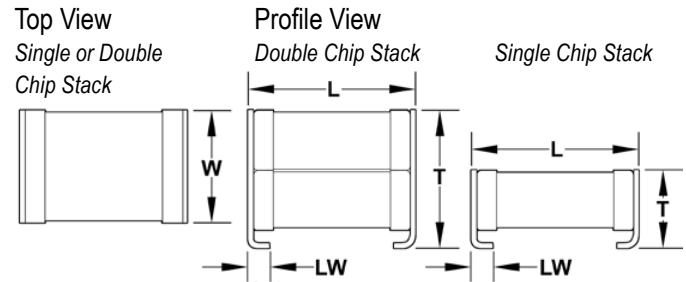

Chip Stack	EIA Size Code	Metric Size Code	L Length	W Width	T Thickness	LW Lead Width	Mounting Technique
Single	1210	3225	3.50 (.138) ± 0.30 (.012)	2.60 (.102) ± 0.30 (.012)	3.35 (.132) ± 0.10 (.004)	0.80 (.032) ± 0.15 (.006)	Solder Reflow Only
	1812	4532	5.00 (.197) ± 0.50 (.020)	3.50 (.138) ± 0.50 (.020)	2.65 (.104) ± 0.35 (.014)	1.10 (.043) ± 0.30 (.012)	
	2220	5650	6.00 (.236) ± 0.50 (.020)	5.00 (.197) ± 0.50 (.020)	3.50 (.138) ± 0.30 (.012)	1.60 (.063) ± 0.30 (.012)	
Double	1210	3225	3.50 (.138) ± 0.30 (.012)	2.60 (.102) ± 0.30 (.012)	6.15 (.242) ± 0.15 (.006)	0.80 (.031) ± 0.15 (.006)	
	1812	4532	5.00 (.197) ± 0.50 (.020)	3.50 (.138) ± 0.50 (.020)	5.00 (.197) ± 0.50 (.020)	1.10 (.043) ± 0.30 (.012)	
	2220	5650	6.00 (.236) ± 0.50 (.020)	5.00 (.197) ± 0.50 (.020)	5.00 (.197) ± 0.50 (.020)	1.60 (.063) ± 0.30 (.012)	

Qualification/Certification

Commercial grade products are subject to internal qualification. Details regarding test methods and conditions are referenced in Table 4, Performance and Reliability.

Environmental Compliance

Pb-Free and RoHS compliant

Electrical Parameters/Characteristics

Item	Parameters/Characteristics
Operating Temperature Range	-55°C to +125°C
Capacitance Change with Reference to +25°C and 0 VDC Applied (TCC)	±15%
Aging Rate (Max % Cap Loss/Decade Hour)	3.0%
Dielectric Withstanding Voltage	250% of rated voltage (5 ± 1 seconds and charge/discharge not exceeding 50mA)
Dissipation Factor (DF) Maximum Limits @ 25°C	5%(10V), 3.5%(16V & 25V) and 2.5%(50V to 250V)
Insulation Resistance (IR) Limit @ 25°C	See Insulation Resistance Limit Table (Rated voltage applied for 120 ± 5 secs @ 25°C)

Regarding Aging Rate: Capacitance measurements (including tolerance) are indexed to a referee time of 48 or 1000 Hours. Please refer to a part number specific datasheet for referee time details.

To obtain IR limit, divide $M\Omega \cdot \mu F$ value by the capacitance and compare to $G\Omega$ limit. Select the lower of the two limits.

Capacitance and Dissipation Factor (DF) measured under the following conditions:

1kHz ± 50Hz and 1.0 ± 0.2 Vrms if capacitance $\leq 10\mu F$

120Hz ± 10Hz and 0.5 ± 0.1 Vrms if capacitance $> 10\mu F$

Note: When measuring capacitance it is important to ensure the set voltage level is held constant. The HP4284 & Agilent E4980 have a feature known as Automatic Level Control (ALC). The ALC feature should be switched to "ON".

Post Environmental Limits

High Temperature Life, Biased Humidity, Moisture Resistance					
Dielectric	Rated DC Voltage	Capacitance Value	DF (%)	Cap Shift	IR
X7R	>25	All	3.0	± 20%	10% of Initial Limit
	16 / 25		5.0		
	< 16		7.5		

Insulation Resistance Limit Table

EIA Case Size	1000 megohm microfarads or 100GΩ	500 megohm microfarads or 10GΩ
1210	< 0.39μF	≥ 0.39μF
1812	< 2.2μF	≥ 2.2μF
2220	< 10μF	≥ 10μF

Electrical Characteristics

Z and ESR C1210C475M5R1C

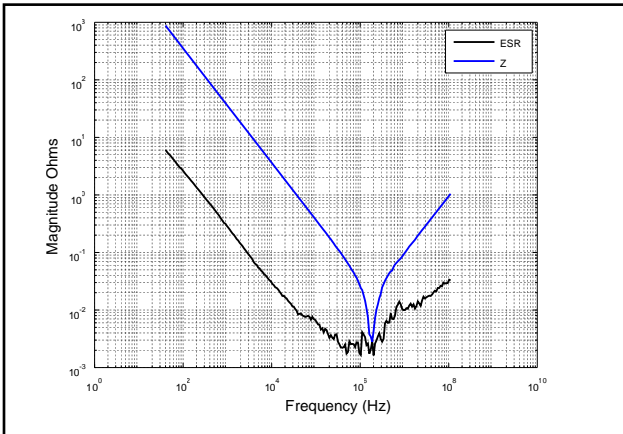

Z and ESR C2220C225MAR2C

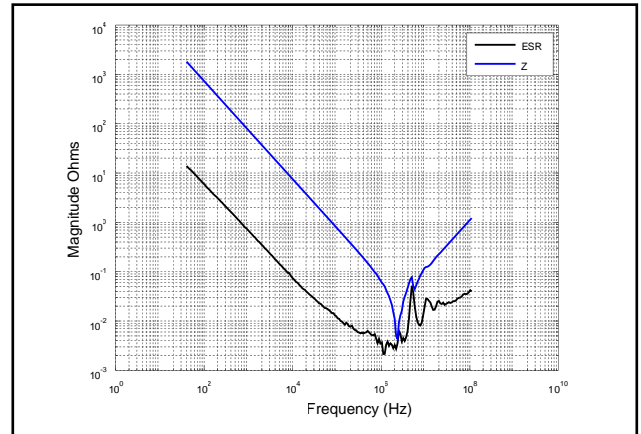

Z and ESR C2220C476M3R2C

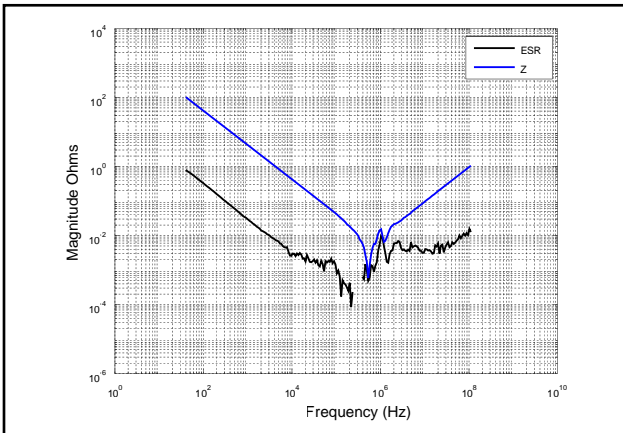

Electrical Characteristics

ESR - 1812, .10 μ F, 50V X7R

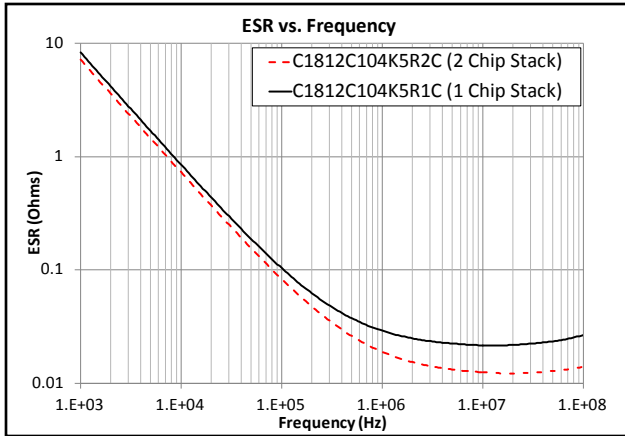

Impedance - 1812, .10 μ F, 50V X7R

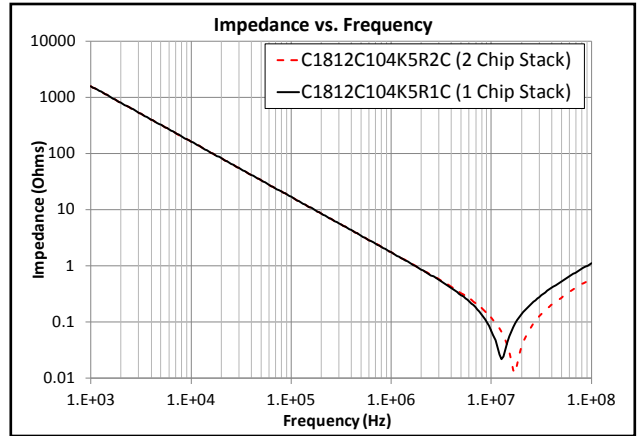

ESR - 1210, .22 μ F, 50V X7R

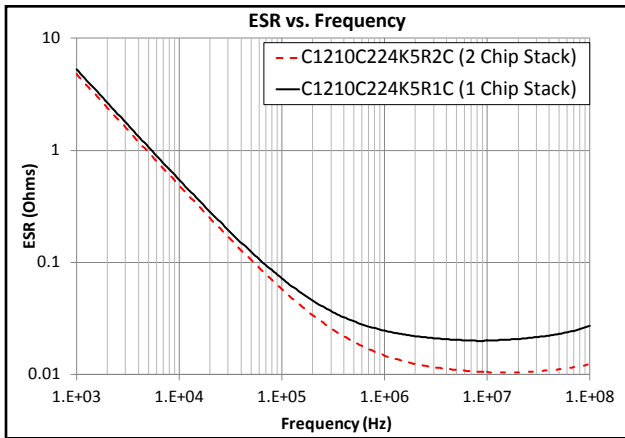

Impedance - 1210, .22 μ F, 50V X7R

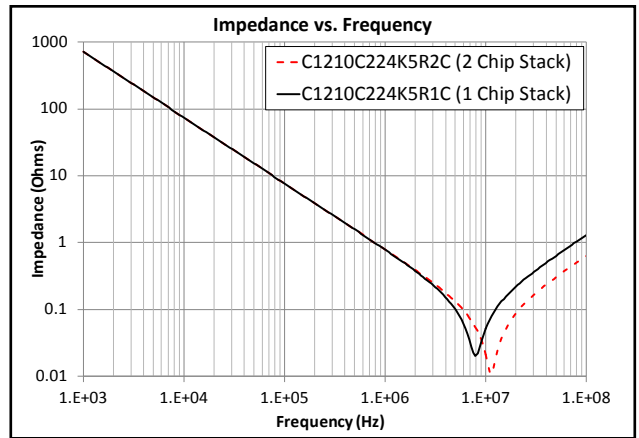

Electrical Characteristics cont

Microphonics - 1210, 4.7 μ F, 50V, X7R

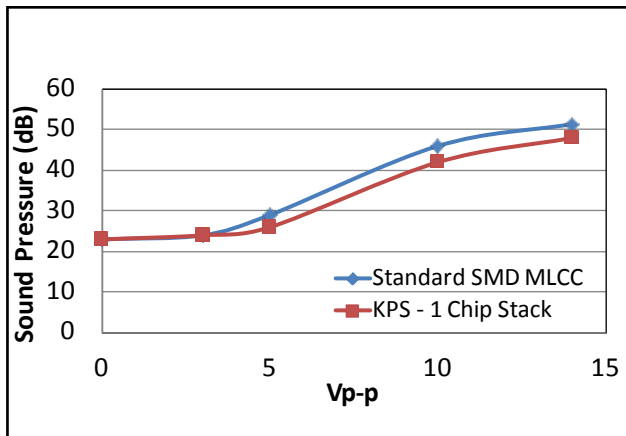

Microphonics - 2220, 22 μ F, 50V, X7R

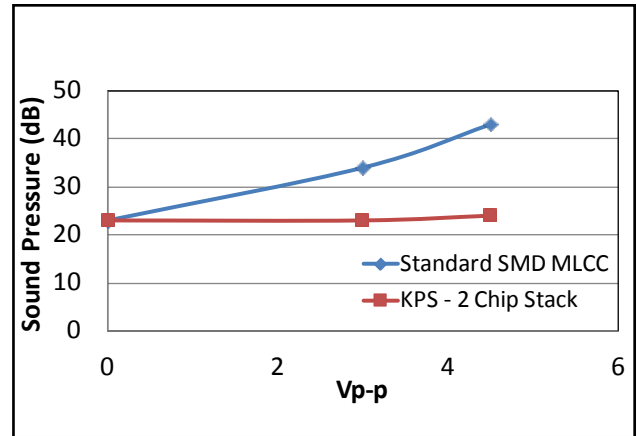

Microphonics - 2220, 47 μ F, 25V, X7R

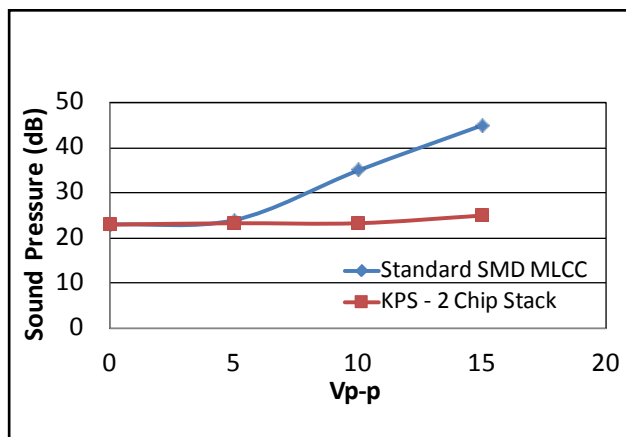

Microphonics - 1210, 22 μ F, 25V, X7R

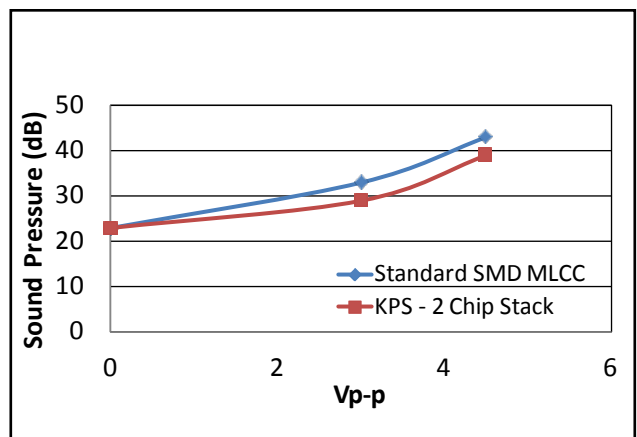

Competitive Comparison

Microphonics - 1210, 4.7 μ F, 50V, X7R

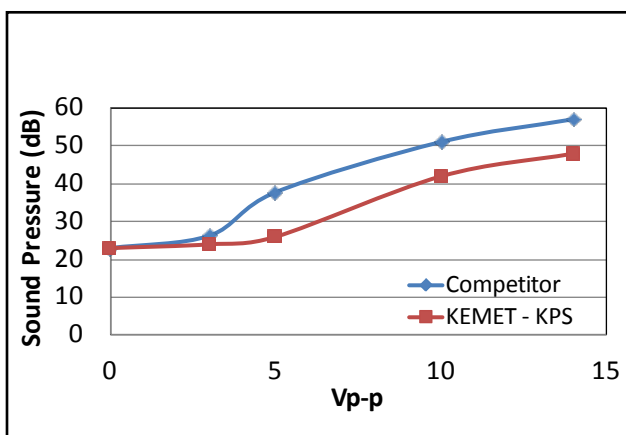

Ripple Current (Arms) 2220, 22 μ F, 50V

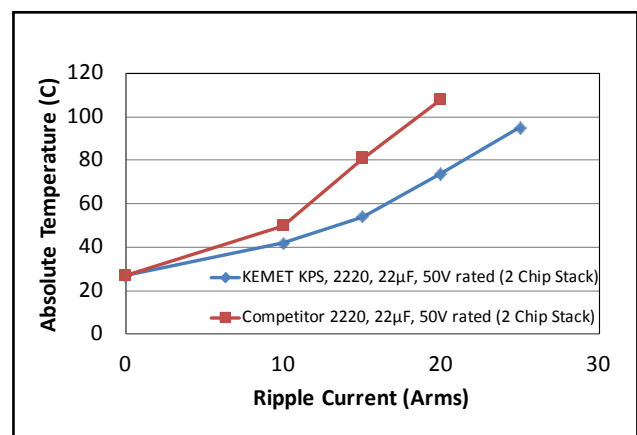

Note: Refer to Table 4 for test method.

Electrical Characteristics

Board Flex vs. Termination Type

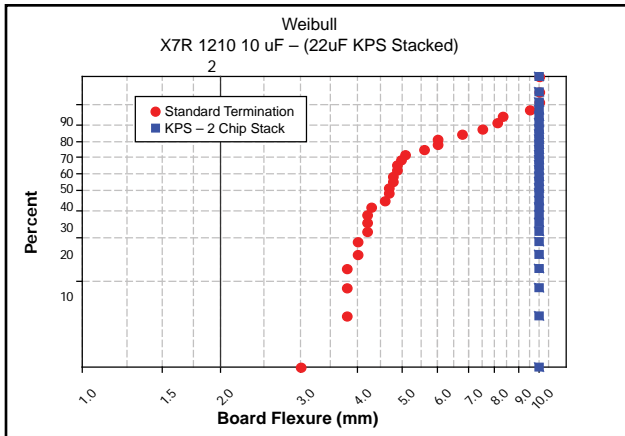

Board Flex vs. Termination Type

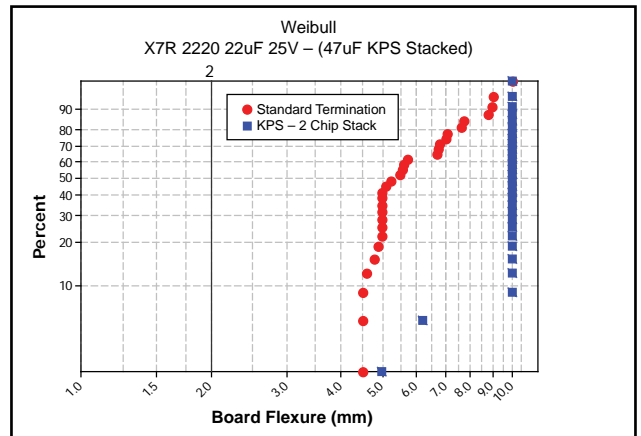

Board Flexure to 10mm

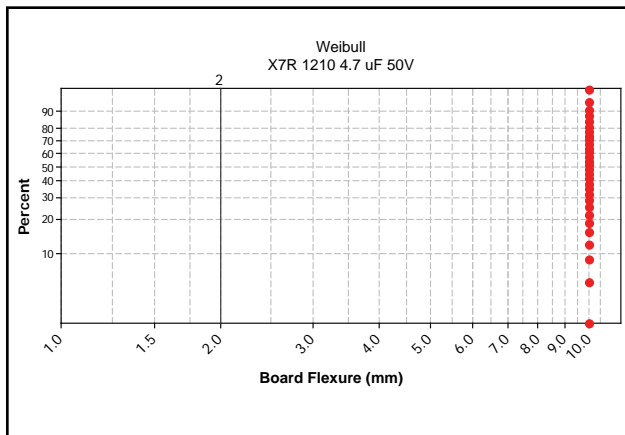

Board Flexure to 10mm

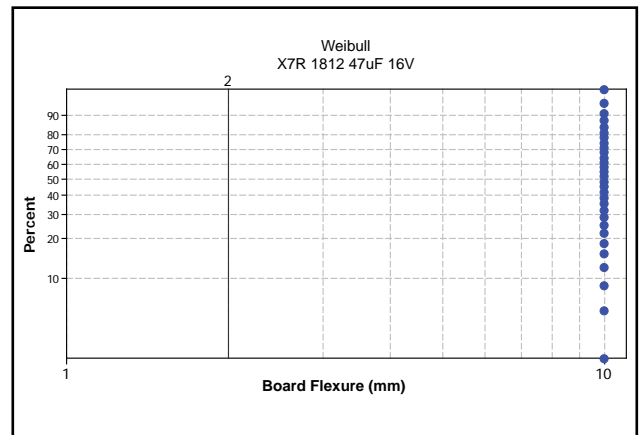

Table 1 – KPS Series, X7R Dielectric, (1210 - 2220 Case Sizes)

Cap	Cap Code	Series		C1210						C1812					C2220				
		Voltage Code		8	4	3	5	1	A	4	3	5	1	A	4	3	5	1	A
		Voltage DC		10	16	25	50	100	250	16	25	50	100	250	16	25	50	100	250
		Cap Tolerance		Product Availability and Chip Thickness Codes - See Table 2 for Chip Thickness Dimensions															
Single Chip Stack																			
0.10 µF	104	K	M	FV	FV	FV	FV	FV	FV	GP	GP	GP	GP	GP	JP	JP	JP	JP	JP
0.22 µF	224	K	M	FV	FV	FV	FV	FV	FV	GP	GP	GP	GP	GP	JP	JP	JP	JP	JP
0.47 µF	474	K	M	FV	FV	FV	FV	FV	FV	GP	GP	GP	GP	GP	JP	JP	JP	JP	JP
1.0 µF	105	K	M	FV	FV	FV	FV	FV	FV	GP	GP	GP	GP	GP	JP	JP	JP	JP	JP
2.2 µF	225	K	M	FV	FV	FV	FV	FT		GP	GP	GP			JP	JP	JP	JP	
3.3 µF	335	K	M	FV	FV	FV	FV			GP	GP	GP			JP	JP	JP	JP	
4.7 µF	475	K	M	FV	FV	FV	FV			GP	GP	GP			JP	JP	JP	JP	
10 µF	106	K	M	FV	FV	FV				GP	GP				JP	JP	JP		
15 µF	156	K	M	FV											JP	JP			
22 µF	226	K	M	FV											JP	JP			
33 µF	336	K	M																
47 µF	476	K	M																
100 µF	107	K	M																
Double Chip Stack																			
0.10 µF	104		M	FW	FW	FW	FW	FW	FW	GR	GR	GR	GR	GR	JR	JR	JR	JR	JR
0.22 µF	224		M	FW	FW	FW	FW	FW	FW	GR	GR	GR	GR	GR	JR	JR	JR	JR	JR
0.47 µF	474		M	FW	FW	FW	FW	FW	FW	GR	GR	GR	GR	GR	JR	JR	JR	JR	JR
1.0 µF	105		M	FW	FW	FW	FW	FW	FW	GR	GR	GR	GR	GR	JR	JR	JR	JR	JR
2.2 µF	225		M	FW	FW	FW	FW	FW	FW	GR	GR	GR	GR	GR	JR	JR	JR	JR	JR
3.3 µF	335		M	FW	FW	FW	FW	FW	FW	GR	GR	GR	GR	GR	JR	JR	JR	JR	JR
4.7 µF	475		M	FW	FW	FW	FW	FW		GR	GR	GR			JR	JR	JR	JR	
10 µF	106		M	FW	FW	FW	FW			GR	GR	GR			JR	JR	JR		
22 µF	226		M	FW	FW	FW				GR	GR				JR	JR	JR		
33 µF	336		M	FW											JR	JR	JR		
47 µF	476		M	FW											JR	JR			
100 µF	107		M																
220 µF	227		M																
Cap	Cap Code	Voltage DC		10	16	25	50	100	250	16	25	50	100	250	16	25	50	100	250
		Voltage Code		8	4	3	5	1	A	4	3	5	1	A	4	3	5	1	A
		Series		C1210						C1812					C2220				

Table 2 – Chip Thickness / Packaging Quantities

Thickness Code	Chip Size	Thickness ± Range (mm)	Qty per Reel 7" Plastic	Qty per Reel 13" Plastic
FV	1210	3.35 ± 0.10	600	2000
FW	1210	6.15 ± 0.15	300	1000
GP	1812	2.65 ± 0.35	500	2000
GR	1812	5.00 ± 0.50	400	1700
JP	2220	3.50 ± 0.30	300	1300
JR	2220	5.00 ± 0.50	200	800

Package Quantity Based on Finished Chip Thickness Specifications

Soldering Process

Recommended Soldering Technique:

- Solder reflow only

Recommended Soldering Profile:

- KEMET recommends following the guidelines outlined in IPC/JEDEC J-STD-020

Table 3 – KPS Land Pattern Design Recommendations

EIA Size Code	Metric Size Code	Median (Nominal) Land Protrusion (mm)		
		X	Y	2xC
1210	3225	1.75	1.14	3.00
1812	4532	2.87	1.35	4.39
2220	5650	4.78	2.08	5.38

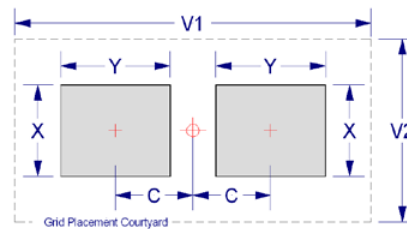
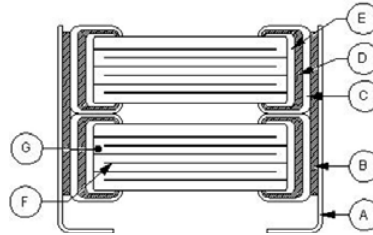

Table 4 – Performance & Reliability: Test Methods & Conditions

Stress	Reference	Test or Inspection Method
Terminal Strength	JIS-C-6429	Appendix 1, Note: Force of 1.8kg for 60 seconds.
Board Flex	JIS-C-6429	Appendix 2, Note: 2mm (min) for all except 3mm for COG.
Solderability	J-STD-002	Magnification 50 X. Conditions:
		a) Method B, 4 hrs @ 155°C, dry heat @ 235°C
		b) Method B @ 215°C category 3
		c) Method D, category 3 @ 260°C
Temperature Cycling	JESD22 Method JA-104	1000 cycles (-55°C to +125°C), Measurement at 24 hrs. +/- 2 hrs after test conclusion.
Biased Humidity	MIL-STD-202 Method 103	Load Humidity: 1000 hours 85°C/85%RH and Rated Voltage. Add 100K ohm resistor. Measurement at 24 hrs. +/- 2 hrs after test conclusion.
		Low Volt Humidity: 1000 hours 85°C/85%RH and 1.5V. Add 100K ohm resistor. Measurement at 24 hrs. +/- 2 hrs after test conclusion.
Moisture Resistance	MIL-STD-202 Method 106	t = 24 hours/cycle. Steps 7a & 7b not required. Unpowered. Measurement at 24 hrs. +/- 2 hrs after test conclusion.
Thermal Shock	MIL-STD-202 Method 107	-55°C/+125°C. Note: Number of cycles required-300, maximum transfer time-20 seconds, dwell time-15 minutes. Air-Air.
High Temperature Life	MIL-STD-202 Method 108/ EIA-198	1000 hours at 125°C (85°C for X5R, Z5U and Y5V) with 2X rated voltage applied.
Storage Life	MIL-STD-202 Method 108	150°C, 0VDC, for 1000 hours.
Mechanical Shock	MIL-STD-202 Method 213	Figure 1 of Method 213, Condition F.
Resistance to Solvents	MIL-STD-202 Method 215	Add aqueous wash chemical - OKEM Clean or equivalent.

Construction

Ref	Name	Material
A	Leadframe	Phosphor Bronze - Alloy 510
B	Leadframe Attach	High Temp Solder
C	Termination	Cu
D		Ni
E		Sn
F	Electrode	Ni
G	Dielectric	BaTiO ₃



Storage and Handling

Ceramic chip capacitors should be stored in normal working environments. While the chips themselves are quite robust in other environments, solderability will be degraded by exposure to high temperatures, high humidity, corrosive atmospheres, and long term storage. In addition, packaging materials will be degraded by high temperature – reels may soften or warp, and tape peel force may increase. KEMET recommends that maximum storage temperature not exceed 40°C, and maximum storage humidity not exceed 70% relative humidity. In addition, temperature fluctuations should be minimized to avoid condensation on the parts, and atmospheres should be free of chlorine and sulfur bearing compounds. For optimized solderability, chip stock should be used promptly, preferably within 1.5 years of receipt.

KPS MIL Series, SMPS Stacked Capacitors, MIL-PRF-49470, DSCC 87106, 50VDC–500VDC (Commercial, Military, & Space Grades)

KEMET
 CHARGED:

Overview

KEMET Power Solutions (KPS) MIL Series ceramic stacked capacitors are available in commercial, military and space grades and are well suited for standard and high reliability switch mode power supply (SMPS) and pulse energy applications. Qualified under performance specification MIL-PRF-49470, our military and space grade products meet or exceed the requirements outlined by DSCC (Defense Supply Center, Columbus) and are available in both B (standard reliability) & T (high reliability) product levels. MIL-PRF-49470 was developed as part of a cooperative effort between the U.S. Military, NASA and SMPS suppliers to produce a robust replacement to cancelled DSCC Drawing 87106.

The KPS MIL Series is constructed using large chip multilayer ceramic capacitors (MLCCs), horizontally stacked and secured to a lead-frame termination system using a high melting point (HMP) solder alloy. The lead frame isolates the MLCCs from the

printed circuit board (PCB) while establishing a parallel circuit configuration. Mechanically isolating the capacitors from the PCB improves mechanical and thermal stress performance, while the parallel circuit configuration allows for bulk capacitance in the same or smaller design footprint.

Available in BX, BR, BQ, and X7R dielectrics, these devices are available in encapsulated and unencapsulated styles in both surface mountable and through-hole configurations. Their low Equivalent Series Resistance (ESR) and Equivalent Series Inductance (ESL) make them ideally suited for input and output filtering of power supply as well as snubber applications. The encapsulated styles are primarily used where increased mechanical and environmental protection is required, such as in avionics systems.

Benefits

- -55°C to +125°C operating temperature range
- High frequency performance
- Bulk capacitance in a reduced footprint
- MIL-PRF-49470 QPL
- Military Case Codes 3, 4 and 5
- Space Grade available (“T” Level)
- DSCC approved (87106)
- Commercial/Industrial Grade available
- Customer specific requirements available
- Low ESR and ESL
- High thermal stability
- High ripple current capability
- Higher reliability than aluminum electrolytic or tantalum
- Available encapsulated or unencapsulated

Applications

- Military
- Space
- Industrial
- Input and output filtering on power supplies – often found on “capacitor banks“
- Snubber circuits
- Radar filtering (28V/microwave burst)

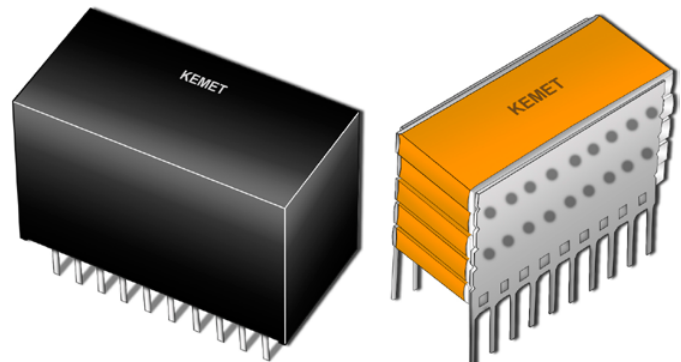

MIL-PRF-49470 Ordering Information

M49470	R	01	474	K	C	N
Performance Specification Indicating MIL-PRF-49470 ¹	Dielectric Classification/Characteristic ²	Performance Specification Sheet Number (Indicating MIL-PRF-49470/1) ³	Capacitance Code (pF)	Capacitance Tolerance	Rated Voltage (DC)	Lead Configuration ⁴
M49470 = B level T49470 = T level A "T" prefix is used in place of the "M" for T level product.	Q = BQ R = BR X = BX	01 = Unencapsulated 02 = Encapsulated	2 Sig. Digits + Number of Zeros	J = ±5% K = ±10% M = ±20%	A = 50V B = 100V C = 200V E = 500V	N = Straight Pin L = Formed "L" M = Formed "L" J = Formed "J" K = Formed "J"

¹ Indicates performance and reliability requirements. "B" level represents standard reliability. "T" level represents high reliability.

¹ Please refer to performance specification sheet MIL-PRF-49470 for details regarding test levels. The latest revision of the specification sheet is available through DSCC.

^{1,3} Test level option "T" is not available on encapsulated stacked devices (i.e. MIL-PRF-49470/2).

² Dielectric classification and characteristic details are outlined in the "Electrical Parameters" section of this document.

⁴ Lead configuration and dimension details are outlined in the "Dimensions" section of this document.

KPS MIL Series, SMPS Stacks Ordering Information

(Do not use this ordering code if a QPL MIL-SPEC part type is required. Please order using MIL-SPEC ordering code. Details regarding MIL-PRF-49470 QPL ordering information is outlined above.)

L1	R	N	30	C	106	K	S	12	
Product Family ¹	Dielectric Classification/Characteristic ²	Lead Configuration ³	Case Size / Case Code (CC)	Rated Voltage (DC)	Capacitance Code (pF)	Capacitance Tolerance	Testing Option ⁴	Maximum Height Dimension (in.) ⁵	
L1 = Unencapsulated L2 = Encapsulated	Q = BQ R = BR X = BX W = X7R	N = Straight L = Formed "L" M = Formed "L" J = Formed "J" K = Formed "J"	30 = CC 3 40 = CC 4 50 = CC 5	3 = 25V 5 = 50V 1 = 100V 2 = 200V C = 500V B = 630V D = 1000V	2 Sig. Digits + Number of Zeros	J = ±5% K = ±10% M = ±20%	B = M49470 "B" Level T = M49470 "T" Level C = DSCC87106 S = Commercial X = Non-Standard (Customer Specific Requirements)	Unencapsulated 12 = 0.12" 24 = 0.24" 36 = 0.36" 48 = 0.48" 65 = 0.65"	Encapsulated 27 = 0.27" 39 = 0.39" 53 = 0.53" 66 = 0.66" 80 = 0.80"

^{1, 4} Test level option "T" is not available on encapsulated stacked devices, i.e., MIL-PRF-49470/2. If a QPL MIL-Spec part type is required, please order using the MIL-Spec ordering code.

² Dielectric classification and characteristic details are outlined in the "Electrical Parameters" section of this document.

³ Lead configuration and dimension details are outlined in the "Dimensions" section of this document. Additional lead configurations may be available. Contact KEMET for details.

⁴ Indicates performance and reliability requirements. Testing option details are outlined in the "Performance and Reliability" section of this document.

⁴ Please refer to performance specification sheet MIL-PRF-49470 for additional details regarding test levels. The latest revision of the specification sheet is available through DSCC.

⁴ DSCC Drawing 87106 was cancelled on 01/03/2005. MIL-PRF-49470 capacitors are preferred over DSCC Drawing 87106 capacitors.

⁵ Maximum height dimensions are provided in product tables 1A, 1B, and 1C of this document

Ordering Information Requirements per DSCC Drawing 87106

DSCC Drawing 87106 was cancelled on 01/03/2005. Customers can continue to order per 87106 requirements using the original DSCC ordering code, i.e., 87106-001. When available, MIL-PRF-49470 devices are preferred over DSCC Drawing 87106. The MIL-PRF-49470 military specification product provides additional quality assurance provisions that are not required by the DSCC drawing. These extra provisions create a more robust replacement.

Construction

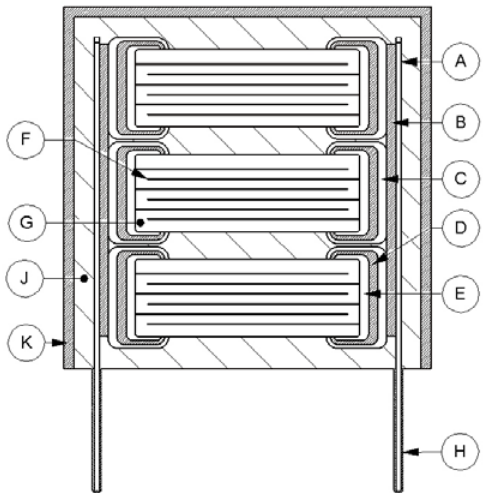

Note: Image is exaggerated in order to clearly identify all components of construction

Reference	Item	Material
A	Leadframe	Phosphor Bronze - Alloy 510
B	Leadframe Attach Solder	Sn10, Pb88, Ag2
C	Termination System ¹	SnPb (4% min.)
D		Ni
E		Ag
		Solderable Silver
F	Electrode	PdAg
G	Dielectric	BaTiO ³
H	Lead Solder	Sn60, Pb40
J	Encapsulation ²	Molding Compound
K		Diallyl-Phthalate (DAP)

¹ KEMET reserves the right to construct these devices using either of the termination systems outlined.

² Encapsulated product only, i.e., MIL-PRF-49470/2 and L2 product families.

Unencapsulated (M49470/1 & L1) Product Dimensions – Inches (Millimeters)

Case Code	C Lead Spacing ±0.025 (0.635)	E Length ±0.010 (0.250)	D Width Min.	D Width Max.	A Height Max.	Seating Plane ¹ ±0.010 (0.250)	Number of Leads per Side	Mounting Technique
3	0.450 (11.43)	0.500 (12.70)	0.950 (24.13)	1.075 (27.30)	Refer to tables 1A & 1C for specific maximum A dimension	0.055 (1.40)	10	Solder reflow only
4	0.400 (10.16)	0.440 (11.18)	0.350 (8.89)	0.425 (10.80)			4	
5	0.250 (6.35)	0.300 (7.62)	0.224 (5.69)	0.275 (6.98)			3	

¹ Only applies to lead style "N" (straight).

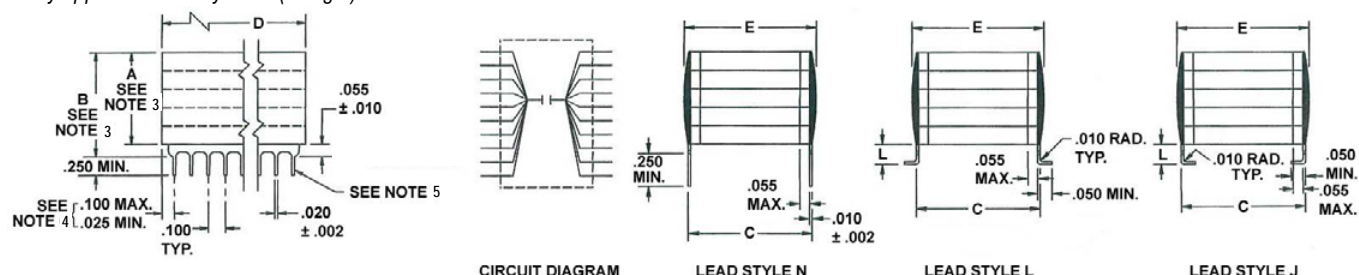

1. Unless otherwise specified, tolerances are ±.010" (0.25mm).
2. Metric equivalents for C, D and E dimensions are provided for general information only.
3. For maximum B dimension, add .065" (1.65mm) to the appropriate A dimension. For all lead styles, the number of chips is determined by the capacitance and voltage rating.
4. For case code 5, dimensions shall be .100" (2.54mm) maximum and .012" (0.30mm) minimum.
5. Lead alignment within pin rows shall be within ±.005" (0.13mm).

Unencapsulated & Encapsulated Lead Configurations – Inches (Millimeters)

Lead Style Symbol	Lead Style	L Lead Length
N	(N) Straight	0.250 Min. (6.35)
L	(L) Formed	0.070 ± 0.010 (1.78 ± 0.25)
M		0.045 ± 0.010 (1.14 ± 0.25)
J	(J) Formed	0.070 ± 0.010 (1.78 ± 0.25)
K		0.045 ± 0.010 (1.14 ± 0.25)

Additional lead configurations may be available. Contact KEMET for details.

Encapsulated (M49470/2 & L2) Product Dimensions – Inches (Millimeters)

Case Code	C Lead Spacing ±0.025 (0.635)	E Length Max.	D Width ±0.635 (±0.025)	A Height	Number of Leads per Side	Mounting Technique
3	0.450 (11.43)	0.580 (14.73)	1.155 (29.34)	Refer to table 1B for specific maximum A dimension	10	Solder reflow only
4	0.400 (10.16)	0.485 (12.32)	0.485 (12.32)		4	
5	0.250 (6.35)	0.355 (9.02)	0.355 (9.02)		3	

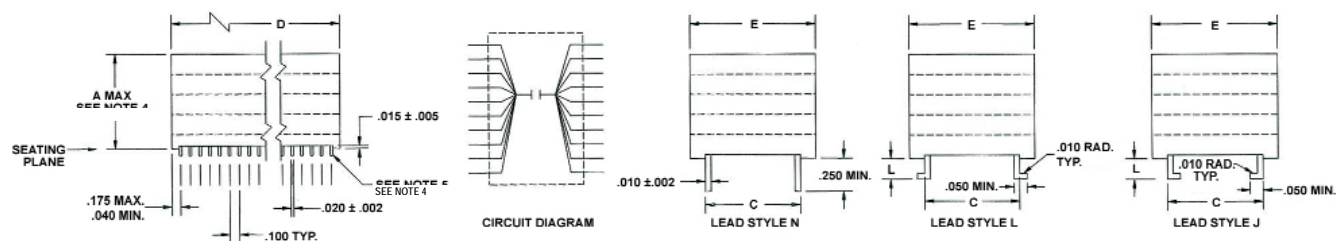

1. Dimensions are in inches.
2. Metric equivalents are given for general information only.
3. Unless otherwise specified, tolerances are ±.010" (0.25mm).
4. Lead alignment within pin rows shall be within ±.005" (0.13mm).

Unencapsulated & Encapsulated Lead Configurations – Inches (Millimeters)

Lead Style Symbol	Lead Style	L Lead Length
N	(N) Straight	0.250 Min. (6.35)
L	(L) Formed	0.070 ± 0.010 (1.78 ± 0.25)
M		0.045 ± 0.010 (1.14 ± 0.25)
J	(J) Formed	0.070 ± 0.010 (1.78 ± 0.25)
K		0.045 ± 0.010 (1.14 ± 0.25)

Additional lead configurations may be available. Contact KEMET for details.

Qualification Inspection Per MIL-PRF-49470

Inspection	Test Method Paragraph
Group I	
Thermal shock and voltage conditioning	4.8.5
Group II	
Visual and mechanical Inspection	4.8.4
Group III	
Low temperature storage	4.8.23
Barometric pressure	4.8.9
Terminal strength	4.8.10
Group IV	
Voltage-temperature limits	4.8.13.1
Vibration, high frequency	4.8.14
Immersion	4.8.15
Group V	
Shock, specified pulse	4.8.16
Resistance to soldering heat	4.8.17
Moisture resistance	4.8.18
Group VI	
DPA (T level only)	4.8.19
Group VII	
Humidity, steady state, low voltage (T level only)	4.8.21
Group VIII	
Life	4.8.22

Environmental Compliance

These devices do not meet RoHS criteria

Electrical Parameters/Performance Characteristics: BQ Dielectric

Item	Parameters/Characteristics
Operating Temperature Range	-55°C to +125°C
Capacitance Change with Reference to +25°C and 0 VDC Applied (TCC)	±15%
Capacitance Change with Reference to +25°C and 100% Rated VDC Applied	+15%, -50%
Aging Rate (Max % Cap Loss/Decade Hour)	1%
Dielectric Withstanding Voltage	250% of rated DC voltage for voltage rating < 500V 150% of rated DC voltage for voltage rating of 500V (5 ± 1 seconds and charge/discharge not exceeding 50mA)
Dissipation Factor (DF) Maximum Limit @ 25°C	2.5%
Insulation Resistance (IR) Limit @ 25°C	1000 megohm microfarads (minimum) or 100GΩ
Insulation Resistance (IR) Limit @ 125°C	100 megohm microfarads (minimum) or 10GΩ

Regarding aging rate: Capacitance measurements (including tolerance) are indexed to a referee time of 1000 hours.

To obtain IR limit, divide MΩ-μF value by the capacitance and compare to GΩ limit. Select the lower of the two limits.

Capacitance and Dissipation Factor (DF) measured under the following conditions:

1kHz ± 100Hz at 1.0Vrms ± 0.2 Vrms (open circuit voltage).

Note: When measuring capacitance it is important to ensure the set voltage level is held constant. The HP4284 & Agilent E4980 have a feature known as Automatic Level Control (ALC). The ALC feature should be switched to "ON."

Electrical Parameters/Performance Characteristics: BR Dielectric

Item	Parameters/Characteristics
Operating Temperature Range	-55°C to +125°C
Capacitance Change with Reference to +25°C and 0 VDC Applied (TCC)	±15%
Capacitance Change with Reference to +25°C and 100% Rated VDC Applied	+15%, -40%
Aging Rate (Max % Cap Loss/Decade Hour)	1%
Dielectric Withstanding Voltage	250% of rated DC voltage for voltage rating < 500V 150% of rated DC voltage for voltage rating of 500V (5 ± 1 seconds and charge/discharge not exceeding 50mA)
Dissipation Factor (DF) Maximum Limit @ 25°C	2.5%
Insulation Resistance (IR) Limit @ 25°C	1000 megohm microfarads (minimum) or 100GΩ
Insulation Resistance (IR) Limit @ 125°C	100 megohm microfarads (minimum) or 10GΩ

Regarding aging rate: Capacitance measurements (including tolerance) are indexed to a referee time of 1000 hours.

To obtain IR limit, divide MΩ-μF value by the capacitance and compare to GΩ limit. Select the lower of the two limits.

Capacitance and Dissipation Factor (DF) measured under the following conditions:

1kHz ± 100Hz at 1.0Vrms ± 0.2 Vrms (open circuit voltage).

Note: When measuring capacitance it is important to ensure the set voltage level is held constant. The HP4284 & Agilent E4980 have a feature known as Automatic Level Control (ALC). The ALC feature should be switched to "ON."

Electrical Parameters/Performance Characteristics: BX Dielectric

Item	Parameters/Characteristics
Operating Temperature Range	-55°C to +125°C
Capacitance Change with Reference to +25°C and 0 VDC Applied (TCC)	±15%
Capacitance Change with Reference to +25°C and 100% Rated VDC Applied	+15%, -25%
Aging Rate (Max % Cap Loss/Decade Hour)	1%
Dielectric Withstanding Voltage	250% of rated DC voltage for voltage rating < 500V 150% of rated DC voltage for voltage rating of 500V (5 ± 1 seconds and charge/discharge not exceeding 50mA)
Dissipation Factor (DF) Maximum Limit @ 25°C	2.5%
Insulation Resistance (IR) Limit @ 25°C	1000 megohm microfarads (minimum) or 100GΩ
Insulation Resistance (IR) Limit @ 125°C	100 megohm microfarads (minimum) or 10GΩ

Regarding aging rate: Capacitance measurements (including tolerance) are indexed to a referee time of 1000 hours.

To obtain IR limit, divide $M\Omega\text{-}\mu F$ value by the capacitance and compare to $G\Omega$ limit. Select the lower of the two limits.

Capacitance and Dissipation Factor (DF) measured under the following conditions:

1kHz ± 100Hz at 1.0Vrms ± 0.2 Vrms (open circuit voltage).

Note: When measuring capacitance it is important to ensure the set voltage level is held constant. The HP4284 & Agilent E4980 have a feature known as Automatic Level Control (ALC). The ALC feature should be switched to "ON."

Electrical Parameters/Performance Characteristics: X7R Dielectric

Item	Parameters/Characteristics
Operating Temperature Range	-55°C to +125°C
Capacitance Change with Reference to +25°C and 0 VDC Applied (TCC)	±15%
Aging Rate (Max % Cap Loss/Decade Hour)	3.0%
Dielectric Withstanding Voltage	250% of rated voltage (5 ± 1 seconds and charge/discharge not exceeding 50mA)
Dissipation Factor (DF) Maximum Limit @ 25°C	3.5% (25V) and 2.5% (50V to 200V)
Insulation Resistance (IR) Limit @ 25°C	1000 megohm microfarads or 100GΩ (Rated voltage applied for 120 ± 5 secs @ 25°C)

Regarding aging rate: Capacitance measurements (including tolerance) are indexed to a referee time of 1000 hours.

To obtain IR limit, divide $M\Omega\text{-}\mu F$ value by the capacitance and compare to $G\Omega$ limit. Select the lower of the two limits.

Capacitance and Dissipation Factor (DF) measured under the following conditions:

1kHz ± 50Hz and 1.0 ± 0.2 Vrms if capacitance ≤ 10μF.

20Hz ± 10Hz and 0.5 ± 0.1 Vrms if capacitance > 10μF.

Note: When measuring capacitance it is important to ensure the set voltage level is held constant. The HP4284 & Agilent E4980 have a feature known as Automatic Level Control (ALC). The ALC feature should be switched to "ON."

Table 1A – MIL-PRF-49470/1, Product Selection 50VDC-200VDC

MIL-PRF-49470/1 Unencapsulated, Horizontally Stacked						
MIL-PRF-49470 P/N ¹	Cap (µF)	Case Code	Height A inch (mm)	Cap Tol.	Lead Config.	KEMET P/N ¹
50VDC - BX Dielectric						
(1)49470X01105(2)A(3)	1	5	0.120 (3.05)	K, M	N, L, M, J, K	L1X(3)505105(2)(4)12
(1)49470X01125(2)A(3)	1.2	5	0.120 (3.05)	K, M	N, L, M, J, K	L1X(3)505125(2)(4)12
(1)49470X01155(2)A(3)	1.5	5	0.240 (6.10)	K, M	N, L, M, J, K	L1X(3)505155(2)(4)24
(1)49470X01185(2)A(3)	1.8	5	0.240 (6.10)	K, M	N, L, M, J, K	L1X(3)505185(2)(4)24
(1)49470X01225(2)A(3)	2.2	5	0.240 (6.10)	K, M	N, L, M, J, K	L1X(3)505225(2)(4)24
(1)49470X01275(2)A(3)	2.7	5	0.360 (9.14)	K, M	N, L, M, J, K	L1X(3)505275(2)(4)36
(1)49470X01335(2)A(3)	3.3	5	0.360 (9.14)	K, M	N, L, M, J, K	L1X(3)505335(2)(4)36
(1)49470X01475(2)A(3)	3.9	5	0.480 (12.19)	K, M	N, L, M, J, K	L1X(3)505475(2)(4)48
(1)49470X01395(2)A(3)	3.9	5	0.480 (12.19)	K, M	N, L, M, J, K	L1X(3)505395(2)(4)48
(1)49470X01565(2)A(3)	5.6	5	0.650 (16.51)	K, M	N, L, M, J, K	L1X(3)505565(2)(4)65
(1)49470X01685(2)A(3)	6.8	4	0.360 (9.14)	K, M	N, L, M, J, K	L1X(3)405685(2)(4)36
(1)49470X01825(2)A(3)	8.2	4	0.360 (9.14)	K, M	N, L, M, J, K	L1X(3)405825(2)(4)36
(1)49470X01106(2)A(3)	10	4	0.480 (12.19)	K, M	N, L, M, J, K	L1X(3)405106(2)(4)48
(1)49470X01126(2)A(3)	12	4	0.480 (12.19)	K, M	N, L, M, J, K	L1X(3)405126(2)(4)48
(1)49470X01156(2)A(3)	15	4	0.650 (16.51)	K, M	N, L, M, J, K	L1X(3)405156(2)(4)65
(1)49470X01186(2)A(3)	18	3	0.240 (6.10)	K, M	N, L, M, J, K	L1X(3)305186(2)(4)24
(1)49470X01226(2)A(3)	22	3	0.360 (9.14)	K, M	N, L, M, J, K	L1X(3)305226(2)(4)36
(1)49470X01276(2)A(3)	27	3	0.360 (9.14)	K, M	N, L, M, J, K	L1X(3)305276(2)(4)36
(1)49470X01336(2)A(3)	33	3	0.360 (9.14)	K, M	N, L, M, J, K	L1X(3)305336(2)(4)36
(1)49470X01396(2)A(3)	39	3	0.480 (12.19)	K, M	N, L, M, J, K	L1X(3)305396(2)(4)48
(1)49470X01476(2)A(3)	47	3	0.650 (16.51)	K, M	N, L, M, J, K	L1X(3)305476(2)(4)65
100VDC - BX Dielectric						
(1)49470X01684(2)B(3)	0.68	5	0.120 (3.05)	K, M	N, L, M, J, K	L1X(3)501684(2)(4)12
(1)49470X01824(2)B(3)	0.82	5	0.240 (6.10)	K, M	N, L, M, J, K	L1X(3)501824(2)(4)24
(1)49470X01105(2)B(3)	1	5	0.240 (6.10)	K, M	N, L, M, J, K	L1X(3)501105(2)(4)24
(1)49470X01125(2)B(3)	1.2	5	0.240 (6.10)	K, M	N, L, M, J, K	L1X(3)501125(2)(4)24
(1)49470X01155(2)B(3)	1.5	5	0.360 (9.14)	K, M	N, L, M, J, K	L1X(3)501155(2)(4)36
(1)49470X01185(2)B(3)	1.8	5	0.360 (9.14)	K, M	N, L, M, J, K	L1X(3)501185(2)(4)36
(1)49470X01225(2)B(3)	2.2	5	0.480 (12.19)	K, M	N, L, M, J, K	L1X(3)501225(2)(4)48
(1)49470X01275(2)B(3)	2.7	5	0.480 (12.19)	K, M	N, L, M, J, K	L1X(3)501275(2)(4)48
(1)49470X01335(2)B(3)	3.3	5	0.650 (16.51)	K, M	N, L, M, J, K	L1X(3)501335(2)(4)65
(1)49470X01395(2)B(3)	3.9	4	0.360 (9.14)	K, M	N, L, M, J, K	L1X(3)401395(2)(4)36
(1)49470X01475(2)B(3)	4.7	4	0.360 (9.14)	K, M	N, L, M, J, K	L1X(3)401475(2)(4)36
(1)49470X01565(2)B(3)	5.6	4	0.480 (12.19)	K, M	N, L, M, J, K	L1X(3)401565(2)(4)48
(1)49470X01685(2)B(3)	6.8	4	0.480 (12.19)	K, M	N, L, M, J, K	L1X(3)401685(2)(4)48
(1)49470X01825(2)B(3)	8.2	4	0.650 (16.51)	K, M	N, L, M, J, K	L1X(3)401825(2)(4)65
(1)49470X01106(2)B(3)	10	3	0.240 (6.10)	K, M	N, L, M, J, K	L1X(3)301106(2)(4)24
(1)49470X01126(2)B(3)	12	3	0.240 (6.10)	K, M	N, L, M, J, K	L1X(3)301126(2)(4)24
(1)49470X01156(2)B(3)	15	3	0.360 (9.14)	K, M	N, L, M, J, K	L1X(3)301156(2)(4)36
(1)49470X01186(2)B(3)	18	3	0.360 (9.14)	K, M	N, L, M, J, K	L1X(3)301186(2)(4)36
(1)49470X01226(2)B(3)	22	3	0.480 (12.19)	K, M	N, L, M, J, K	L1X(3)301226(2)(4)48
(1)49470X01276(2)B(3)	27	3	0.650 (16.51)	K, M	N, L, M, J, K	L1X(3)301276(2)(4)65
200VDC - BR Dielectric						
(1)49470R01474(2)C(3)	0.47	5	0.240 (6.10)	K, M	N, L, M, J, K	L1R(3)502474(2)(4)24
(1)49470R01564(2)C(3)	0.56	5	0.240 (6.10)	K, M	N, L, M, J, K	L1R(3)502564(2)(4)24
(1)49470R01684(2)C(3)	0.68	5	0.360 (9.14)	K, M	N, L, M, J, K	L1R(3)502684(2)(4)36
(1)49470R01824(2)C(3)	0.82	5	0.360 (9.14)	K, M	N, L, M, J, K	L1R(3)502824(2)(4)36
(1)49470R01105(2)C(3)	1	5	0.480 (12.19)	K, M	N, L, M, J, K	L1R(3)502105(2)(4)48
MIL-PRF-49470 P/N ¹	Cap (µF)	Case Code	Height A inch (mm)	Cap Tolerance	Lead Config.	KEMET P/N ¹

¹ Complete P/N requires additional characters in the numbered positions provided in order to indicate product level (B level or T level), capacitance tolerance and lead configuration. For each numbered position, available options are as follows:

- (1) Test level character "M" for B level, or "T" for T level (MIL-PRF-49470/1 part number only)
- (2) Capacitance tolerance character "K" or "M"
- (3) Lead style character "N", "L", "M", "J" or "K"
- (4) Test level character "B" for B level, or "T" for T level (KEMET part number only)

Table 1A – MIL-PRF-49470 /1, Product Selection 200VDC-500VDC con't.

MIL-PRF-49470/1 Unencapsulated, Horizontally Stacked						
MIL-PRF-49470 P/N ¹	Cap (µF)	Case Code	Height A inch (mm)	Cap Tol.	Lead Config.	KEMET P/N ¹
(1)49470R01125(2)C(3)	1.2	5	0.480 (12.19)	K, M	N, L, M, J, K	L1R(3)502125(2)(4)48
(1)49470R01155(2)C(3)	1.5	5	0.650 (16.51)	K, M	N, L, M, J, K	L1R(3)502155(2)(4)65
(1)49470R01185(2)C(3)	1.8	4	0.360 (9.14)	K, M	N, L, M, J, K	L1R(3)402185(2)(4)36
(1)49470R01225(2)C(3)	2.2	4	0.360 (9.14)	K, M	N, L, M, J, K	L1R(3)402225(2)(4)36
(1)49470R01275(2)C(3)	2.7	4	0.480 (12.19)	K, M	N, L, M, J, K	L1R(3)402275(2)(4)48
(1)49470R01335(2)C(3)	3.3	4	0.480 (12.19)	K, M	N, L, M, J, K	L1R(3)402335(2)(4)48
(1)49470R01395(2)C(3)	3.9	4	0.650 (16.51)	K, M	N, L, M, J, K	L1R(3)402395(2)(4)65
(1)49470R01475(2)C(3)	4.7	3	0.240 (6.10)	K, M	N, L, M, J, K	L1R(3)302475(2)(4)24
(1)49470R01565(2)C(3)	5.6	3	0.240 (6.10)	K, M	N, L, M, J, K	L1R(3)302565(2)(4)24
(1)49470R01685(2)C(3)	6.8	3	0.360 (9.14)	K, M	N, L, M, J, K	L1R(3)302685(2)(4)36
(1)49470R01825(2)C(3)	8.2	3	0.360 (9.14)	K, M	N, L, M, J, K	L1R(3)302825(2)(4)36
(1)49470R01106(2)C(3)	10	3	0.480 (12.19)	K, M	N, L, M, J, K	L1R(3)302106(2)(4)48
(1)49470R01126(2)C(3)	12	3	0.650 (16.51)	K, M	N, L, M, J, K	L1R(3)302126(2)(4)65
500VDC - BQ Dielectric						
(1)49470Q01154(2)E(3)	0.15	5	0.120 (3.05)	K, M	N, L, M, J, K	L1Q(3)50C154(2)(4)12
(1)49470Q01184(2)E(3)	0.18	5	0.240 (6.10)	K, M	N, L, M, J, K	L1Q(3)50C184(2)(4)24
(1)49470Q01224(2)E(3)	0.22	5	0.240 (6.10)	K, M	N, L, M, J, K	L1Q(3)50C224(2)(4)24
(1)49470Q01274(2)E(3)	0.27	5	0.240 (6.10)	K, M	N, L, M, J, K	L1Q(3)50C274(2)(4)24
(1)49470Q01334(2)E(3)	0.33	5	0.360 (9.14)	K, M	N, L, M, J, K	L1Q(3)50C334(2)(4)36
(1)49470Q01394(2)E(3)	0.39	5	0.360 (9.14)	K, M	N, L, M, J, K	L1Q(3)50C394(2)(4)36
(1)49470Q01474(2)E(3)	0.47	5	0.360 (9.14)	K, M	N, L, M, J, K	L1Q(3)50C474(2)(4)36
(1)49470Q01564(2)E(3)	0.56	5	0.480 (12.19)	K, M	N, L, M, J, K	L1Q(3)50C564(2)(4)48
(1)49470Q01684(2)E(3)	0.68	5	0.650 (16.51)	K, M	N, L, M, J, K	L1Q(3)50C684(2)(4)65
(1)49470Q01824(2)E(3)	0.82	4	0.360 (9.14)	K, M	N, L, M, J, K	L1Q(3)40C824(2)(4)36
(1)49470Q01105(2)E(3)	1	4	0.360 (9.14)	K, M	N, L, M, J, K	L1Q(3)40C105(2)(4)36
(1)49470Q01125(2)E(3)	1.2	4	0.360 (9.14)	K, M	N, L, M, J, K	L1Q(3)40C125(2)(4)36
(1)49470Q01155(2)E(3)	1.5	4	0.480 (12.19)	K, M	N, L, M, J, K	L1Q(3)40C155(2)(4)48
(1)49470Q01185(2)E(3)	1.8	4	0.650 (16.51)	K, M	N, L, M, J, K	L1Q(3)40C185(2)(4)65
(1)49470Q01225(2)E(3)	2.2	3	0.240 (6.10)	K, M	N, L, M, J, K	L1Q(3)30C225(2)(4)24
(1)49470Q01275(2)E(3)	2.7	3	0.360 (9.14)	K, M	N, L, M, J, K	L1Q(3)30C275(2)(4)36
(1)49470Q01335(2)E(3)	3.3	3	0.360 (9.14)	K, M	N, L, M, J, K	L1Q(3)30C335(2)(4)36
(1)49470Q01395(2)E(3)	3.9	3	0.360 (9.14)	K, M	N, L, M, J, K	L1Q(3)30C395(2)(4)36
(1)49470Q01475(2)E(3)	4.7	3	0.480 (12.19)	K, M	N, L, M, J, K	L1Q(3)30C475(2)(4)48
(1)49470Q01565(2)E(3)	5.6	3	0.650 (16.51)	K, M	N, L, M, J, K	L1Q(3)30C565(2)(4)65
MIL-PRF-49470 P/N ¹	Cap (µF)	Case Code	Height A inch (mm)	Cap Tolerance	Lead Config.	KEMET P/N ¹

¹ Complete P/N requires additional characters in the numbered positions provided in order to indicate product level (B level or T level), capacitance tolerance and lead configuration. For each numbered position, available options are as follows:

- (1) Test level character "M" for B level, or "T" for T level (MIL-PRF-49470/1 part number only)
- (2) Capacitance tolerance character "K" or "M"
- (3) Lead style character "N", "L", "M", "J" or "K"
- (4) Test level character "B" for B level, or "T" for T level (KEMET part number only)

Table 1B – MIL-PRF-49470/2, Product Selection 50VDC-200VDC

MIL-PRF-49470/2 Encapsulated, Horizontally Stacked						
MIL-PRF-49470 P/N ¹	Cap (µF)	Case Code	Height A inch (mm)	Cap Tol.	Lead Config.	KEMET P/N ¹
50VDC - BX Dielectric						
M49470X02125(1)A(2)	1.2	5	0.270 (6.86)	K, M	N, L, M, J, K	L2X(2)505125(1)B27
M49470X02155(1)A(2)	1.5	5	0.390 (9.91)	K, M	N, L, M, J, K	L2X(2)505155(1)B39
M49470X02185(1)A(2)	1.8	5	0.390 (9.91)	K, M	N, L, M, J, K	L2X(2)505185(1)B39
M49470X02225(1)A(2)	2.2	5	0.390 (9.91)	K, M	N, L, M, J, K	L2X(2)505225(1)B39
M49470X02275(1)A(2)	2.7	5	0.530 (13.46)	K, M	N, L, M, J, K	L2X(2)505275(1)B53
M49470X02335(1)A(2)	3.3	5	0.530 (13.46)	K, M	N, L, M, J, K	L2X(2)505335(1)B53
M49470X02475(1)A(2)	3.9	5	0.660 (16.76)	K, M	N, L, M, J, K	L2X(2)505475(1)B66
M49470X02395(1)A(2)	4.7	5	0.660 (16.76)	K, M	N, L, M, J, K	L2X(2)505395(1)B66
M49470X02565(1)A(2)	5.6	5	0.800 (20.32)	K, M	N, L, M, J, K	L2X(2)505565(1)B80
M49470X02685(1)A(2)	6.8	4	0.530 (13.46)	K, M	N, L, M, J, K	L2X(2)405685(1)B53
M49470X02825(1)A(2)	8.2	4	0.530 (13.46)	K, M	N, L, M, J, K	L2X(2)405825(1)B53
M49470X02106(1)A(2)	10	4	0.660 (16.76)	K, M	N, L, M, J, K	L2X(2)505106(1)B66
M49470X02126(1)A(2)	12	4	0.660 (16.76)	K, M	N, L, M, J, K	L2X(2)405126(1)B66
M49470X02156(1)A(2)	15	4	0.800 (20.32)	K, M	N, L, M, J, K	L2X(2)405156(1)B80
M49470X02186(1)A(2)	18	3	0.390 (9.91)	K, M	N, L, M, J, K	L2X(2)305186(1)B39
M49470X02226(1)A(2)	22	3	0.530 (13.46)	K, M	N, L, M, J, K	L2X(2)305226(1)B53
M49470X02276(1)A(2)	27	3	0.530 (13.46)	K, M	N, L, M, J, K	L2X(2)305276(1)B53
M49470X02336(1)A(2)	33	3	0.530 (13.46)	K, M	N, L, M, J, K	L2X(2)305336(1)B53
M49470X02396(1)A(2)	39	3	0.660 (16.76)	K, M	N, L, M, J, K	L2X(2)305396(1)B66
M49470X02476(1)A(2)	47	3	0.800 (20.32)	K, M	N, L, M, J, K	L2X(2)305476(1)B80
100VDC - BX Dielectric						
M49470X02684(1)B(2)	0.68	5	0.270 (6.86)	K, M	N, L, M, J, K	L2X(2)501684(1)B27
M49470X02824(1)B(2)	0.82	5	0.390 (9.91)	K, M	N, L, M, J, K	L2X(2)501824(1)B39
M49470X02105(1)B(2)	1	5	0.390 (9.91)	K, M	N, L, M, J, K	L2X(2)501105(1)B39
M49470X02125(1)B(2)	1.2	5	0.390 (9.91)	K, M	N, L, M, J, K	L2X(2)501125(1)B39
M49470X02155(1)B(2)	1.5	5	0.530 (13.46)	K, M	N, L, M, J, K	L2X(2)501155(1)B53
M49470X02185(1)B(2)	1.8	5	0.530 (13.46)	K, M	N, L, M, J, K	L2X(2)501185(1)B53
M49470X02225(1)B(2)	2.2	5	0.660 (16.76)	K, M	N, L, M, J, K	L2X(2)501225(1)B66
M49470X02275(1)B(2)	2.7	5	0.660 (16.76)	K, M	N, L, M, J, K	L2X(2)501275(1)B66
M49470X02335(1)B(2)	3.3	5	0.800 (20.32)	K, M	N, L, M, J, K	L2X(2)501335(1)B80
M49470X02395(1)B(2)	3.9	4	0.530 (13.46)	K, M	N, L, M, J, K	L2X(2)401395(1)B53
M49470X02475(1)B(2)	4.7	4	0.530 (13.46)	K, M	N, L, M, J, K	L2X(2)401475(1)B53
M49470X02565(1)B(2)	5.6	4	0.660 (16.76)	K, M	N, L, M, J, K	L2X(2)401565(1)B66
M49470X02685(1)B(2)	6.8	4	0.660 (16.76)	K, M	N, L, M, J, K	L2X(2)401685(1)B66
M49470X02825(1)B(2)	8.2	4	0.800 (20.32)	K, M	N, L, M, J, K	L2X(2)401825(1)B80
M49470X02106(1)B(2)	10	3	0.390 (9.91)	K, M	N, L, M, J, K	L2X(2)301106(1)B39
M49470X02126(1)B(2)	12	3	0.390 (9.91)	K, M	N, L, M, J, K	L2X(2)301126(1)B39
M49470X02156(1)B(2)	15	3	0.530 (13.46)	K, M	N, L, M, J, K	L2X(2)301156(1)B53
M49470X02186(1)B(2)	18	3	0.530 (13.46)	K, M	N, L, M, J, K	L2X(2)301186(1)B53
M49470X02226(1)B(2)	22	3	0.660 (16.76)	K, M	N, L, M, J, K	L2X(2)301226(1)B66
M49470X02276(1)B(2)	27	3	0.800 (20.32)	K, M	N, L, M, J, K	L2X(2)301276(1)B80
200VDC - BR Dielectric						
M49470R02474(1)C(2)	0.47	5	0.390 (9.91)	K, M	N, L, M, J, K	L2R(2)502474(1)B39
M49470R02564(1)C(2)	0.56	5	0.390 (9.91)	K, M	N, L, M, J, K	L2R(2)502564(1)B39
M49470R02684(1)C(2)	0.68	5	0.530 (13.46)	K, M	N, L, M, J, K	L2R(2)502684(1)B53
M49470R02824(1)C(2)	0.82	5	0.530 (13.46)	K, M	N, L, M, J, K	L2R(2)502824(1)B53
M49470R02105(1)C(2)	1	5	0.660 (16.76)	K, M	N, L, M, J, K	L2R(2)502105(1)B66
M49470R02125(1)C(2)	1.2	5	0.660 (16.76)	K, M	N, L, M, J, K	L2R(2)502125(1)B66
M49470R02155(1)C(2)	1.5	5	0.800 (20.32)	K, M	N, L, M, J, K	L2R(2)502155(1)B80
M49470R02185(1)C(2)	1.8	4	0.530 (13.46)	K, M	N, L, M, J, K	L2R(2)402185(1)B53
M49470R02225(1)C(2)	2.2	4	0.530 (13.46)	K, M	N, L, M, J, K	L2R(2)402225(1)B53
MIL-PRF-49470 P/N ¹	Cap (µF)	Case Code	Height A inch (mm)	Cap Tolerance	Lead Config.	KEMET P/N ¹

¹ Complete P/N requires additional characters in the numbered positions provided in order to indicate capacitance tolerance and lead configuration. For each numbered position, available options are as follows:

- (1) Capacitance tolerance character "K" or "M"
- (2) Lead style character "N", "L", "M", "J" or "K"

Table 1B – MIL-PRF-49470 /2, Product Selection 200VDC-500VDC con't

MIL-PRF-49470/2 Encapsulated, Horizontally Stacked						
MIL-PRF-49470 P/N ¹	Cap (μF)	Case Code	Height A inch (mm)	Cap Tol.	Lead Config.	KEMET P/N ¹
M49470R02275(1)C(2)	2.7	4	0.660 (16.76)	K, M	N, L, M, J, K	L2R(2)402275(1)B66
M49470R02335(1)C(2)	3.3	4	0.660 (16.76)	K, M	N, L, M, J, K	L2R(2)402335(1)B66
M49470R02395(1)C(2)	3.9	4	0.800 (20.32)	K, M	N, L, M, J, K	L2R(2)402395(1)B80
M49470R02475(1)C(2)	4.7	3	0.390 (9.91)	K, M	N, L, M, J, K	L2R(2)302475(1)B39
M49470R02565(1)C(2)	5.6	3	0.390 (9.91)	K, M	N, L, M, J, K	L2R(2)302565(1)B39
M49470R02685(1)C(2)	6.8	3	0.530 (13.46)	K, M	N, L, M, J, K	L2R(2)302685(1)B53
M49470R02825(1)C(2)	8.2	3	0.530 (13.46)	K, M	N, L, M, J, K	L2R(2)302825(1)B53
M49470R02106(1)C(2)	10	3	0.660 (16.76)	K, M	N, L, M, J, K	L2R(2)302106(1)B66
M49470R02126(1)C(2)	12	3	0.800 (20.32)	K, M	N, L, M, J, K	L2R(2)302126(1)B80
500VDC - BQ Dielectric						
M49470Q02154(1)E(2)	0.15	5	0.270 (6.86)	K, M	N, L, M, J, K	L2Q(2)50C154(1)B27
M49470Q02184(1)E(2)	0.18	5	0.390 (9.91)	K, M	N, L, M, J, K	L2Q(2)50C184(1)B39
M49470Q02224(1)E(2)	0.22	5	0.390 (9.91)	K, M	N, L, M, J, K	L2Q(2)50C224(1)B39
M49470Q02274(1)E(2)	0.27	5	0.390 (9.91)	K, M	N, L, M, J, K	L2Q(2)50C274(1)B39
M49470Q02334(1)E(2)	0.33	5	0.530 (13.46)	K, M	N, L, M, J, K	L2Q(2)50C334(1)B53
M49470Q02394(1)E(2)	0.39	5	0.530 (13.46)	K, M	N, L, M, J, K	L2Q(2)50C394(1)B53
M49470Q02474(1)E(2)	0.47	5	0.530 (13.46)	K, M	N, L, M, J, K	L2Q(2)50C474(1)B53
M49470Q02564(1)E(2)	0.56	5	0.660 (16.76)	K, M	N, L, M, J, K	L2Q(2)50C564(1)B66
M49470Q02684(1)E(2)	0.68	5	0.800 (20.32)	K, M	N, L, M, J, K	L2Q(2)50C684(1)B80
M49470Q02824(1)E(2)	0.82	4	0.530 (13.46)	K, M	N, L, M, J, K	L2Q(2)40C824(1)B53
M49470Q02105(1)E(2)	1	4	0.530 (13.46)	K, M	N, L, M, J, K	L2Q(2)40C105(1)B53
M49470Q02125(1)E(2)	1.2	4	0.530 (13.46)	K, M	N, L, M, J, K	L2Q(2)40C125(1)B53
M49470Q02155(1)E(2)	1.5	4	0.660 (16.76)	K, M	N, L, M, J, K	L2Q(2)40C155(1)B66
M49470Q02185(1)E(2)	1.8	4	0.800 (20.32)	K, M	N, L, M, J, K	L2Q(2)40C185(1)B80
M49470Q02225(1)E(2)	2.2	3	0.390 (9.91)	K, M	N, L, M, J, K	L2Q(2)30C225(1)B39
M49470Q02275(1)E(2)	2.7	3	0.530 (13.46)	K, M	N, L, M, J, K	L2Q(2)30C275(1)B53
M49470Q02335(1)E(2)	3.3	3	0.530 (13.46)	K, M	N, L, M, J, K	L2Q(2)30C335(1)B53
M49470Q02395(1)E(2)	3.9	3	0.530 (13.46)	K, M	N, L, M, J, K	L2Q(2)30C395(1)B53
M49470Q02475(1)E(2)	4.7	3	0.660 (16.76)	K, M	N, L, M, J, K	L2Q(2)30C475(1)B66
M49470Q02565(1)E(2)	5.6	3	0.800 (20.32)	K, M	N, L, M, J, K	L2Q(2)30C565(1)B80
M49470Q02565(1)E(2)	5.6	3	0.800 (20.32)	K, M	N, L, M, J, K	L2Q(2)30C565(1)B65
MIL-PRF-49470 P/N ¹	Cap (μF)	Case Code	Height A inch (mm)	Cap Tolerance	Lead Config.	KEMET P/N ¹

¹ Complete P/N requires additional characters in the numbered positions provided in order to indicate capacitance tolerance and lead configuration. For each numbered position, available options are as follows:

- (1) Capacitance tolerance character "K" or "M"
- (2) Lead style character "N", "L", "M", "J" or "K"

Table 1C – Product Selection 25VDC

Commercial/Non-Standard – Customer Specific Unencapsulated, Horizontally Stacked					
KEMET P/N ¹	Cap (μF)	Case Code	Height A inch (mm)	Cap Tolerance	Lead Config.
25VDC - BX Dielectric					
L1X(1)503824(2)(3)12	0.82	5	0.120 (3.05)	K, M	N, L, M, J, K
L1X(1)503105(2)(3)12	1	5	0.120 (3.05)	K, M	N, L, M, J, K
L1X(1)503125(2)(3)12	1.2	5	0.120 (3.05)	K, M	N, L, M, J, K
L1X(1)503155(2)(3)12	1.5	5	0.120 (3.05)	K, M	N, L, M, J, K
L1X(1)503185(2)(3)24	1.8	5	0.240 (6.10)	K, M	N, L, M, J, K
L1X(1)403225(2)(3)12	2.2	4	0.120 (3.05)	K, M	N, L, M, J, K
L1X(1)503225(2)(3)24	2.2	5	0.240 (6.10)	K, M	N, L, M, J, K
L1X(1)503255(2)(3)24	2.5	5	0.240 (6.10)	K, M	N, L, M, J, K
L1X(1)403275(2)(3)12	2.7	4	0.120 (3.05)	K, M	N, L, M, J, K
L1X(1)503275(2)(3)24	2.7	5	0.240 (6.10)	K, M	N, L, M, J, K
L1X(1)403335(2)(3)12	3.3	4	0.120 (3.05)	K, M	N, L, M, J, K
L1X(1)503335(2)(3)36	3.3	5	0.360 (9.14)	K, M	N, L, M, J, K
L1X(1)403395(2)(3)12	3.9	4	0.120 (3.05)	K, M	N, L, M, J, K
L1X(1)503395(2)(3)36	3.9	5	0.360 (9.14)	K, M	N, L, M, J, K
L1X(1)403475(2)(3)12	4.7	4	0.120 (3.05)	K, M	N, L, M, J, K
L1X(1)503475(2)(3)36	4.7	5	0.360 (9.14)	K, M	N, L, M, J, K
L1X(1)403565(2)(3)24	5.6	4	0.240 (6.10)	K, M	N, L, M, J, K
L1X(1)503565(2)(3)48	5.6	5	0.480 (12.19)	K, M	N, L, M, J, K
L1X(1)403605(2)(3)24	6	4	0.240 (6.10)	K, M	N, L, M, J, K
L1X(1)503605(2)(3)48	6	5	0.480 (12.19)	K, M	N, L, M, J, K
L1X(1)303685(2)(3)12	6.8	3	0.120 (3.05)	K, M	N, L, M, J, K
L1X(1)403685(2)(3)24	6.8	4	0.240 (6.10)	K, M	N, L, M, J, K
L1X(1)503685(2)(3)65	6.8	5	0.650 (16.51)	K, M	N, L, M, J, K
L1X(1)403755(2)(3)24	7.5	4	0.240 (6.10)	K, M	N, L, M, J, K
L1X(1)503755(2)(3)65	7.5	5	0.650 (16.51)	K, M	N, L, M, J, K
L1X(1)303825(2)(3)12	8.2	3	0.120 (3.05)	K, M	N, L, M, J, K
L1X(1)403825(2)(3)24	8.2	4	0.240 (6.10)	K, M	N, L, M, J, K
L1X(1)303106(2)(3)12	10	3	0.120 (3.05)	K, M	N, L, M, J, K
L1X(1)403106(2)(3)24	10	4	0.240 (6.10)	K, M	N, L, M, J, K
L1X(1)303116(2)(3)12	11	3	0.120 (3.05)	K, M	N, L, M, J, K
L1X(1)303126(2)(3)12	12	3	0.120 (3.05)	K, M	N, L, M, J, K
L1X(1)403126(2)(3)36	12	4	0.360 (9.14)	K, M	N, L, M, J, K
L1X(1)303156(2)(3)12	15	3	0.120 (3.05)	K, M	N, L, M, J, K
L1X(1)403156(2)(3)36	15	4	0.360 (9.14)	K, M	N, L, M, J, K
L1X(1)303166(2)(3)24	16	3	0.240 (6.10)	K, M	N, L, M, J, K
L1X(1)403166(2)(3)48	16	4	0.480 (12.19)	K, M	N, L, M, J, K
L1X(1)303186(2)(3)24	18	3	0.240 (6.10)	K, M	N, L, M, J, K
L1X(1)403186(2)(3)48	18	4	0.480 (12.19)	K, M	N, L, M, J, K
L1X(1)303206(2)(3)24	20	3	0.240 (6.10)	K, M	N, L, M, J, K
L1X(1)403206(2)(3)48	20	4	0.480 (12.19)	K, M	N, L, M, J, K
L1X(1)303226(2)(3)24	22	3	0.240 (6.10)	K, M	N, L, M, J, K
L1X(1)403226(2)(3)65	22	4	0.650 (16.51)	K, M	N, L, M, J, K
L1X(1)403246(2)(3)65	24	4	0.650 (16.51)	K, M	N, L, M, J, K
L1X(1)303276(2)(3)24	27	3	0.240 (6.10)	K, M	N, L, M, J, K
L1X(1)303306(2)(3)24	30	3	0.240 (6.10)	K, M	N, L, M, J, K
L1X(1)303306(2)(3)36	30	3	0.360 (9.14)	K, M	N, L, M, J, K
L1X(1)303336(2)(3)36	33	3	0.360 (9.14)	K, M	N, L, M, J, K
L1X(1)303396(2)(3)36	39	3	0.360 (9.14)	K, M	N, L, M, J, K
L1X(1)303456(2)(3)36	45	3	0.360 (9.14)	K, M	N, L, M, J, K
L1X(1)303506(2)(3)48	50	3	0.480 (12.19)	K, M	N, L, M, J, K
L1X(1)303546(2)(3)48	54	3	0.480 (12.19)	K, M	N, L, M, J, K
L1X(1)303606(2)(3)48	60	3	0.480 (12.19)	K, M	N, L, M, J, K
KEMET P/N ¹	Cap (μF)	Case Code	Height A inch (mm)	Cap Tolerance	Lead Config.

¹ Complete part number requires additional characters in the numbered positions provided in order to indicate product level (B level or T level), capacitance tolerance and lead configuration. For each numbered position, available options are as follows:

- (1) Test Level character "S" for Commercial, or "X" for non-standard (customer specific)
- (2) Capacitance tolerance character "K" or "M"
- (3) Lead style character "N", "L", "M", "J" or "K"

Table 1C – Commercial/Non-Standard – Product Selection 25VDC-50VDC con't.

Commercial/Non-Standard – Customer Specific Unencapsulated, Horizontally Stacked					
KEMET P/N ¹	Cap (μF)	Case Code	Height A inch (mm)	Cap Tolerance	Lead Config.
L1X(1)303666(2)(3)65	66	3	0.650 (16.51)	K, M	N, L, M, J, K
L1X(1)303726(2)(3)65	72	3	0.650 (16.51)	K, M	N, L, M, J, K
L1X(1)303756(2)(3)65	75	3	0.650 (16.51)	K, M	N, L, M, J, K
50VDC - BX Dielectric					
L1X(1)505824(2)(3)12	0.82	5	0.120 (3.05)	K, M	N, L, M, J, K
L1X(1)505105(2)(3)12	1	5	0.120 (3.05)	K, M	N, L, M, J, K
L1X(1)505125(2)(3)12	1.2	5	0.120 (3.05)	K, M	N, L, M, J, K
L1X(1)505155(2)(3)12	1.5	5	0.120 (3.05)	K, M	N, L, M, J, K
L1X(1)505185(2)(3)24	1.8	5	0.240 (6.10)	K, M	N, L, M, J, K
L1X(1)405225(2)(3)12	2.2	4	0.120 (3.05)	K, M	N, L, M, J, K
L1X(1)505225(2)(3)24	2.2	5	0.240 (6.10)	K, M	N, L, M, J, K
L1X(1)505255(2)(3)24	2.5	5	0.240 (6.10)	K, M	N, L, M, J, K
L1X(1)405275(2)(3)12	2.7	4	0.120 (3.05)	K, M	N, L, M, J, K
L1X(1)505275(2)(3)24	2.7	5	0.240 (6.10)	K, M	N, L, M, J, K
L1X(1)505275(2)(3)36	2.7	5	0.360 (9.14)	K, M	N, L, M, J, K
L1X(1)405335(2)(3)12	3.3	4	0.120 (3.05)	K, M	N, L, M, J, K
L1X(1)505335(2)(3)36	3.3	5	0.360 (9.14)	K, M	N, L, M, J, K
L1X(1)405395(2)(3)12	3.9	4	0.120 (3.05)	K, M	N, L, M, J, K
L1X(1)505395(2)(3)36	3.9	5	0.360 (9.14)	K, M	N, L, M, J, K
L1X(1)405475(2)(3)12	4.7	4	0.120 (3.05)	K, M	N, L, M, J, K
L1X(1)505475(2)(3)36	4.7	5	0.360 (9.14)	K, M	N, L, M, J, K
L1X(1)405565(2)(3)24	5.6	4	0.240 (6.10)	K, M	N, L, M, J, K
L1X(1)505565(2)(3)48	5.6	5	0.480 (12.19)	K, M	N, L, M, J, K
L1X(1)405605(2)(3)24	6	4	0.240 (6.10)	K, M	N, L, M, J, K
L1X(1)505605(2)(3)48	6	5	0.480 (12.19)	K, M	N, L, M, J, K
L1X(1)305685(2)(3)12	6.8	3	0.120 (3.05)	K, M	N, L, M, J, K
L1X(1)405685(2)(3)24	6.8	4	0.240 (6.10)	K, M	N, L, M, J, K
L1X(1)505685(2)(3)65	6.8	5	0.650 (16.51)	K, M	N, L, M, J, K
L1X(1)405755(2)(3)24	7.5	4	0.240 (6.10)	K, M	N, L, M, J, K
L1X(1)505755(2)(3)65	7.5	5	0.650 (16.51)	K, M	N, L, M, J, K
L1X(1)305825(2)(3)12	8.2	3	0.120 (3.05)	K, M	N, L, M, J, K
L1X(1)405825(2)(3)24	8.2	4	0.240 (6.10)	K, M	N, L, M, J, K
L1X(1)305106(2)(3)12	10	3	0.120 (3.05)	K, M	N, L, M, J, K
L1X(1)405106(2)(3)24	10	4	0.240 (6.10)	K, M	N, L, M, J, K
L1X(1)305116(2)(3)12	11	3	0.120 (3.05)	K, M	N, L, M, J, K
L1X(1)305126(2)(3)12	12	3	0.120 (3.05)	K, M	N, L, M, J, K
L1X(1)405126(2)(3)36	12	4	0.360 (9.14)	K, M	N, L, M, J, K
L1X(1)305156(2)(3)12	15	3	0.120 (3.05)	K, M	N, L, M, J, K
L1X(1)405156(2)(3)36	15	4	0.360 (9.14)	K, M	N, L, M, J, K
L1X(1)305166(2)(3)24	16	3	0.240 (6.10)	K, M	N, L, M, J, K
L1X(1)405166(2)(3)48	16	4	0.480 (12.19)	K, M	N, L, M, J, K
L1X(1)305186(2)(3)24	18	3	0.240 (6.10)	K, M	N, L, M, J, K
L1X(1)405186(2)(3)48	18	4	0.480 (12.19)	K, M	N, L, M, J, K
L1X(1)305206(2)(3)24	20	3	0.240 (6.10)	K, M	N, L, M, J, K
L1X(1)405206(2)(3)48	20	4	0.480 (12.19)	K, M	N, L, M, J, K
L1X(1)305226(2)(3)24	22	3	0.240 (6.10)	K, M	N, L, M, J, K
L1X(1)405226(2)(3)65	22	4	0.650 (16.51)	K, M	N, L, M, J, K
L1X(1)405246(2)(3)65	24	4	0.650 (16.51)	K, M	N, L, M, J, K
L1X(1)305276(2)(3)24	27	3	0.240 (6.10)	K, M	N, L, M, J, K
L1X(1)305306(2)(3)24	30	3	0.240 (6.10)	K, M	N, L, M, J, K
L1X(1)305336(2)(3)36	33	3	0.360 (9.14)	K, M	N, L, M, J, K
L1X(1)305396(2)(3)36	39	3	0.360 (9.14)	K, M	N, L, M, J, K
L1X(1)305456(2)(3)36	45	3	0.360 (9.14)	K, M	N, L, M, J, K
KEMET P/N ¹	Cap (μF)	Case Code	Height A inch (mm)	Cap Tolerance	Lead Config.

¹ Complete part number requires additional characters in the numbered positions provided in order to indicate product level (B level or T level), capacitance tolerance and lead configuration. For each numbered position, available options are as follows:

- (1) Test Level character "S" for Commercial, or "X" for non-standard (customer specific)
- (2) Capacitance tolerance character "K" or "M"
- (3) Lead style character "N", "L", "M", "J" or "K"

Table 1C – Commercial/Non-Standard – Product Selection 50VDC-100VDC con't.

Commercial/Non-Standard – Customer Specific Unencapsulated, Horizontally Stacked					
KEMET P/N ¹	Cap (µF)	Case Code	Height A inch (mm)	Cap Tolerance	Lead Config.
L1X(1)305506(2)(3)48	50	3	0.480 (12.19)	K, M	N, L, M, J, K
L1X(1)305546(2)(3)48	54	3	0.480 (12.19)	K, M	N, L, M, J, K
L1X(1)305606(2)(3)48	60	3	0.480 (12.19)	K, M	N, L, M, J, K
L1X(1)305666(2)(3)65	66	3	0.650 (16.51)	K, M	N, L, M, J, K
L1X(1)305726(2)(3)65	72	3	0.650 (16.51)	K, M	N, L, M, J, K
L1X(1)305756(2)(3)65	75	3	0.650 (16.51)	K, M	N, L, M, J, K
100VDC - BR Dielectric					
L1R(1)501564(2)(3)12	0.56	5	0.120 (3.05)	K, M	N, L, M, J, K
L1R(1)501684(2)(3)12	0.68	5	0.120 (3.05)	K, M	N, L, M, J, K
L1R(1)501754(2)(3)12	0.75	5	0.120 (3.05)	K, M	N, L, M, J, K
L1R(1)501824(2)(3)12	0.82	5	0.120 (3.05)	K, M	N, L, M, J, K
L1R(1)501105(2)(3)12	1	5	0.120 (3.05)	K, M	N, L, M, J, K
L1R(1)501125(2)(3)12	1.2	5	0.120 (3.05)	K, M	N, L, M, J, K
L1R(1)401155(2)(3)12	1.5	4	0.120 (3.05)	K, M	N, L, M, J, K
L1R(1)501155(2)(3)24	1.5	5	0.240 (6.10)	K, M	N, L, M, J, K
L1R(1)401185(2)(3)12	1.8	4	0.120 (3.05)	K, M	N, L, M, J, K
L1R(1)501185(2)(3)24	1.8	5	0.240 (6.10)	K, M	N, L, M, J, K
L1R(1)401225(2)(3)12	2.2	4	0.120 (3.05)	K, M	N, L, M, J, K
L1R(1)501225(2)(3)24	2.2	5	0.240 (6.10)	K, M	N, L, M, J, K
L1R(1)501255(2)(3)24	2.5	5	0.240 (6.10)	K, M	N, L, M, J, K
L1R(1)401275(2)(3)12	2.7	4	0.120 (3.05)	K, M	N, L, M, J, K
L1R(1)501275(2)(3)36	2.7	5	0.360 (9.14)	K, M	N, L, M, J, K
L1R(1)401335(2)(3)12	3.3	4	0.120 (3.05)	K, M	N, L, M, J, K
L1R(1)501335(2)(3)36	3.3	5	0.360 (9.14)	K, M	N, L, M, J, K
L1R(1)401395(2)(3)12	3.9	4	0.120 (3.05)	K, M	N, L, M, J, K
L1R(1)501395(2)(3)48	3.9	5	0.480 (12.19)	K, M	N, L, M, J, K
L1R(1)401475(2)(3)24	4.7	4	0.240 (6.10)	K, M	N, L, M, J, K
L1R(1)501475(2)(3)48	4.7	5	0.480 (12.19)	K, M	N, L, M, J, K
L1R(1)301565(2)(3)12	5.6	3	0.120 (3.05)	K, M	N, L, M, J, K
L1R(1)401565(2)(3)24	5.6	4	0.240 (6.10)	K, M	N, L, M, J, K
L1R(1)501565(2)(3)65	5.6	5	0.650 (16.51)	K, M	N, L, M, J, K
L1R(1)301605(2)(3)12	6	3	0.120 (3.05)	K, M	N, L, M, J, K
L1R(1)401605(2)(3)24	6	4	0.240 (6.10)	K, M	N, L, M, J, K
L1R(1)501605(2)(3)65	6	5	0.650 (16.51)	K, M	N, L, M, J, K
L1R(1)301685(2)(3)12	6.8	3	0.120 (3.05)	K, M	N, L, M, J, K
L1R(1)401685(2)(3)24	6.8	4	0.240 (6.10)	K, M	N, L, M, J, K
L1R(1)401755(2)(3)24	7.5	4	0.240 (6.10)	K, M	N, L, M, J, K
L1R(1)301825(2)(3)12	8.2	3	0.120 (3.05)	K, M	N, L, M, J, K
L1R(1)401825(2)(3)36	8.2	4	0.360 (9.14)	K, M	N, L, M, J, K
L1R(1)301106(2)(3)12	10	3	0.120 (3.05)	K, M	N, L, M, J, K
L1R(1)401106(2)(3)36	10	4	0.360 (9.14)	K, M	N, L, M, J, K
L1R(1)301116(2)(3)12	11	3	0.120 (3.05)	K, M	N, L, M, J, K
L1R(1)301126(2)(3)24	12	3	0.240 (6.10)	K, M	N, L, M, J, K
L1R(1)401126(2)(3)48	12	4	0.480 (12.19)	K, M	N, L, M, J, K
L1R(1)301156(2)(3)24	15	3	0.240 (6.10)	K, M	N, L, M, J, K
L1R(1)401156(2)(3)48	15	4	0.480 (12.19)	K, M	N, L, M, J, K
L1R(1)301166(2)(3)24	16	3	0.240 (6.10)	K, M	N, L, M, J, K
L1R(1)401166(2)(3)65	16	4	0.650 (16.51)	K, M	N, L, M, J, K
L1R(1)301186(2)(3)24	18	3	0.240 (6.10)	K, M	N, L, M, J, K
L1R(1)401186(2)(3)65	18	4	0.650 (16.51)	K, M	N, L, M, J, K
L1R(1)301206(2)(3)24	20	3	0.240 (6.10)	K, M	N, L, M, J, K
L1R(1)301226(2)(3)36	22	3	0.360 (9.14)	K, M	N, L, M, J, K
L1R(1)301276(2)(3)36	27	3	0.360 (9.14)	K, M	N, L, M, J, K
KEMET P/N ¹	Cap (µF)	Case Code	Height A inch (mm)	Cap Tolerance	Lead Config.

¹ Complete part number requires additional characters in the numbered positions provided in order to indicate product level (B level or T level), capacitance tolerance and lead configuration. For each numbered position, available options are as follows:

- (1) Test Level character "S" for Commercial, or "X" for non-standard (customer specific)
- (2) Capacitance tolerance character "K" or "M"
- (3) Lead style character "N", "L", "M", "J" or "K"

Table 1C – Commercial/Non-Standard – Product Selection 100VDC-200VDC con't.

Commercial/Non-Standard – Customer Specific Unencapsulated, Horizontally Stacked					
KEMET P/N ¹	Cap (µF)	Case Code	Height A inch (mm)	Cap Tolerance	Lead Config.
L1R(1)301306(2)(3)36	30	3	0.360 (9.14)	K, M	N, L, M, J, K
L1R(1)301336(2)(3)48	33	3	0.480 (12.19)	K, M	N, L, M, J, K
L1R(1)301396(2)(3)48	39	3	0.480 (12.19)	K, M	N, L, M, J, K
L1R(1)301456(2)(3)65	45	3	0.650 (16.51)	K, M	N, L, M, J, K
L1R(1)301506(2)(3)65	50	3	0.650 (16.51)	K, M	N, L, M, J, K
200VDC - BQ Dielectric					
L1Q(1)502334(2)(3)12	0.33	5	0.120 (3.05)	K, M	N, L, M, J, K
L1Q(1)502394(2)(3)12	0.39	5	0.120 (3.05)	K, M	N, L, M, J, K
L1Q(1)502474(2)(3)12	0.47	5	0.120 (3.05)	K, M	N, L, M, J, K
L1Q(1)502564(2)(3)12	0.56	5	0.120 (3.05)	K, M	N, L, M, J, K
L1Q(1)502684(2)(3)12	0.68	5	0.120 (3.05)	K, M	N, L, M, J, K
L1Q(1)502754(2)(3)12	0.75	5	0.120 (3.05)	K, M	N, L, M, J, K
L1Q(1)402824(2)(3)12	0.82	4	0.120 (3.05)	K, M	N, L, M, J, K
L1Q(1)502824(2)(3)24	0.82	5	0.240 (6.10)	K, M	N, L, M, J, K
L1Q(1)402105(2)(3)12	1	4	0.120 (3.05)	K, M	N, L, M, J, K
L1Q(1)502105(2)(3)24	1	5	0.240 (6.10)	K, M	N, L, M, J, K
L1Q(1)402125(2)(3)12	1.2	4	0.120 (3.05)	K, M	N, L, M, J, K
L1Q(1)502125(2)(3)24	1.2	5	0.240 (6.10)	K, M	N, L, M, J, K
L1Q(1)402155(2)(3)12	1.5	4	0.120 (3.05)	K, M	N, L, M, J, K
L1Q(1)502155(2)(3)36	1.5	5	0.360 (9.14)	K, M	N, L, M, J, K
L1Q(1)402185(2)(3)12	1.8	4	0.120 (3.05)	K, M	N, L, M, J, K
L1Q(1)502185(2)(3)36	1.8	5	0.360 (9.14)	K, M	N, L, M, J, K
L1Q(1)402225(2)(3)24	2.2	4	0.240 (6.10)	K, M	N, L, M, J, K
L1Q(1)502225(2)(3)48	2.2	5	0.480 (12.19)	K, M	N, L, M, J, K
L1Q(1)302245(2)(3)12	2.4	3	0.120 (3.05)	K, M	N, L, M, J, K
L1Q(1)502255(2)(3)48	2.5	5	0.480 (12.19)	K, M	N, L, M, J, K
L1Q(1)302275(2)(3)12	2.7	3	0.120 (3.05)	K, M	N, L, M, J, K
L1Q(1)402275(2)(3)24	2.7	4	0.240 (6.10)	K, M	N, L, M, J, K
L1Q(1)502275(2)(3)48	2.7	5	0.480 (12.19)	K, M	N, L, M, J, K
L1Q(1)302335(2)(3)12	3.3	3	0.120 (3.05)	K, M	N, L, M, J, K
L1Q(1)402335(2)(3)24	3.3	4	0.240 (6.10)	K, M	N, L, M, J, K
L1Q(1)502335(2)(3)65	3.3	5	0.650 (16.51)	K, M	N, L, M, J, K
L1Q(1)302365(2)(3)12	3.6	3	0.120 (3.05)	K, M	N, L, M, J, K
L1Q(1)302395(2)(3)12	3.9	3	0.120 (3.05)	K, M	N, L, M, J, K
L1Q(1)402395(2)(3)24	3.9	4	0.240 (6.10)	K, M	N, L, M, J, K
L1Q(1)302475(2)(3)12	4.7	3	0.120 (3.05)	K, M	N, L, M, J, K
L1Q(1)402475(2)(3)36	4.7	4	0.360 (9.14)	K, M	N, L, M, J, K
L1Q(1)302565(2)(3)12	5.6	3	0.120 (3.05)	K, M	N, L, M, J, K
L1Q(1)402565(2)(3)36	5.6	4	0.360 (9.14)	K, M	N, L, M, J, K
L1Q(1)302605(2)(3)12	6	3	0.120 (3.05)	K, M	N, L, M, J, K
L1Q(1)402605(2)(3)36	6	4	0.360 (9.14)	K, M	N, L, M, J, K
L1Q(1)302685(2)(3)24	6.8	3	0.240 (6.10)	K, M	N, L, M, J, K
L1Q(1)402685(2)(3)48	6.8	4	0.480 (12.19)	K, M	N, L, M, J, K
L1Q(1)402755(2)(3)48	7.5	4	0.480 (12.19)	K, M	N, L, M, J, K
L1Q(1)302825(2)(3)24	8.2	3	0.240 (6.10)	K, M	N, L, M, J, K
L1Q(1)402825(2)(3)65	8.2	4	0.650 (16.51)	K, M	N, L, M, J, K
L1Q(1)302106(2)(3)24	10	3	0.240 (6.10)	K, M	N, L, M, J, K
L1Q(1)402106(2)(3)65	10	4	0.650 (16.51)	K, M	N, L, M, J, K
L1Q(1)302116(2)(3)24	11	3	0.240 (6.10)	K, M	N, L, M, J, K
L1Q(1)302126(2)(3)36	12	3	0.360 (9.14)	K, M	N, L, M, J, K
L1Q(1)302156(2)(3)36	15	3	0.360 (9.14)	K, M	N, L, M, J, K
L1Q(1)302166(2)(3)36	16	3	0.360 (9.14)	K, M	N, L, M, J, K
L1Q(1)302186(2)(3)48	18	3	0.480 (12.19)	K, M	N, L, M, J, K
KEMET P/N ¹	Cap (µF)	Case Code	Height A inch (mm)	Cap Tolerance	Lead Config.

¹ Complete part number requires additional characters in the numbered positions provided in order to indicate product level (B level or T level), capacitance tolerance and lead configuration. For each numbered position, available options are as follows:

- (1) Test Level character "S" for Commercial, or "X" for non-standard (customer specific)
- (2) Capacitance tolerance character "K" or "M"
- (3) Lead style character "N", "L", "M", "J" or "K"

Table 1C – Commercial/Non-Standard – Product Selection 200VDC-630VDC con't.

Commercial/Non-Standard – Customer Specific Unencapsulated, Horizontally Stacked					
KEMET P/N ¹	Cap (µF)	Case Code	Height A inch (mm)	Cap Tolerance	Lead Config.
L1Q(1)302206(2)(3)48	20	3	0.480 (12.19)	K, M	N, L, M, J, K
L1Q(1)302226(2)(3)48	22	3	0.480 (12.19)	K, M	N, L, M, J, K
L1Q(1)302276(2)(3)65	27	3	0.650 (16.51)	K, M	N, L, M, J, K
500VDC - X7R Dielectric					
L1W(1)50C124(2)(3)12	0.12	5	0.120 (3.05)	K, M	N, L, M, J, K
L1W(1)50C154(2)(3)12	0.15	5	0.120 (3.05)	K, M	N, L, M, J, K
L1W(1)50C184(2)(3)12	0.18	5	0.120 (3.05)	K, M	N, L, M, J, K
L1W(1)50C224(2)(3)12	0.22	5	0.120 (3.05)	K, M	N, L, M, J, K
L1W(1)50C274(2)(3)12	0.27	5	0.120 (3.05)	K, M	N, L, M, J, K
L1W(1)50C334(2)(3)24	0.33	5	0.240 (6.10)	K, M	N, L, M, J, K
L1W(1)40C394(2)(3)12	0.39	4	0.120 (3.05)	K, M	N, L, M, J, K
L1W(1)50C394(2)(3)24	0.39	5	0.240 (6.10)	K, M	N, L, M, J, K
L1W(1)40C474(2)(3)12	0.47	4	0.120 (3.05)	K, M	N, L, M, J, K
L1W(1)50C474(2)(3)24	0.47	5	0.240 (6.10)	K, M	N, L, M, J, K
L1W(1)50C564(2)(3)24	0.56	5	0.240 (6.10)	K, M	N, L, M, J, K
L1W(1)40C684(2)(3)12	0.68	4	0.120 (3.05)	K, M	N, L, M, J, K
L1W(1)50C684(2)(3)36	0.68	5	0.360 (9.14)	K, M	N, L, M, J, K
L1W(1)50C754(2)(3)36	0.75	5	0.360 (9.14)	K, M	N, L, M, J, K
L1W(1)40C824(2)(3)12	0.82	4	0.120 (3.05)	K, M	N, L, M, J, K
L1W(1)50C824(2)(3)36	0.82	5	0.360 (9.14)	K, M	N, L, M, J, K
L1W(1)30C105(2)(3)12	1	3	0.120 (3.05)	K, M	N, L, M, J, K
L1W(1)40C105(2)(3)24	1	4	0.240 (6.10)	K, M	N, L, M, J, K
L1W(1)50C105(2)(3)48	1	5	0.480 (12.19)	K, M	N, L, M, J, K
L1W(1)30C125(2)(3)12	1.2	3	0.120 (3.05)	K, M	N, L, M, J, K
L1W(1)40C125(2)(3)24	1.2	4	0.240 (6.10)	K, M	N, L, M, J, K
L1W(1)50C125(2)(3)65	1.2	5	0.650 (16.51)	K, M	N, L, M, J, K
L1W(1)30C155(2)(3)12	1.5	3	0.120 (3.05)	K, M	N, L, M, J, K
L1W(1)40C155(2)(3)24	1.5	4	0.240 (6.10)	K, M	N, L, M, J, K
L1W(1)50C155(2)(3)65	1.5	5	0.650 (16.51)	K, M	N, L, M, J, K
L1W(1)40C185(2)(3)36	1.8	4	0.360 (9.14)	K, M	N, L, M, J, K
L1W(1)30C225(2)(3)12	2.2	3	0.120 (3.05)	K, M	N, L, M, J, K
L1W(1)40C225(2)(3)36	2.2	4	0.360 (9.14)	K, M	N, L, M, J, K
L1W(1)30C245(2)(3)12	2.4	3	0.120 (3.05)	K, M	N, L, M, J, K
L1W(1)30C275(2)(3)12	2.7	3	0.120 (3.05)	K, M	N, L, M, J, K
L1W(1)40C275(2)(3)48	2.7	4	0.480 (12.19)	K, M	N, L, M, J, K
L1W(1)30C335(2)(3)24	3.3	3	0.240 (6.10)	K, M	N, L, M, J, K
L1W(1)40C335(2)(3)48	3.3	4	0.480 (12.19)	K, M	N, L, M, J, K
L1W(1)30C365(2)(3)24	3.6	3	0.240 (6.10)	K, M	N, L, M, J, K
L1W(1)30C395(2)(3)24	3.9	3	0.240 (6.10)	K, M	N, L, M, J, K
L1W(1)40C395(2)(3)65	3.9	4	0.650 (16.51)	K, M	N, L, M, J, K
L1W(1)30C475(2)(3)24	4.7	3	0.240 (6.10)	K, M	N, L, M, J, K
L1W(1)30C565(2)(3)24	5.6	3	0.240 (6.10)	K, M	N, L, M, J, K
L1W(1)30C605(2)(3)24	6	3	0.240 (6.10)	K, M	N, L, M, J, K
L1W(1)30C685(2)(3)36	6.8	3	0.360 (9.14)	K, M	N, L, M, J, K
L1W(1)30C825(2)(3)36	8.2	3	0.360 (9.14)	K, M	N, L, M, J, K
L1W(1)30C106(2)(3)48	10	3	0.480 (12.19)	K, M	N, L, M, J, K
L1W(1)30C116(2)(3)65	11	3	0.650 (16.51)	K, M	N, L, M, J, K
L1W(1)30C126(2)(3)65	12	3	0.650 (16.51)	K, M	N, L, M, J, K
630VDC - X7R Dielectric					
L1W(1)50B683(2)(3)12	0.068	5	0.120 (3.05)	K, M	N, L, M, J, K
L1W(1)40B104(2)(3)12	0.1	4	0.120 (3.05)	K, M	N, L, M, J, K
L1W(1)50B104(2)(3)12	0.1	5	0.120 (3.05)	K, M	N, L, M, J, K
KEMET P/N ¹	Cap (µF)	Case Code	Height A inch (mm)	Cap Tolerance	Lead Config.

¹ Complete part number requires additional characters in the numbered positions provided in order to indicate product level (B level or T level), capacitance tolerance and lead configuration. For each numbered position, available options are as follows:

- (1) Test Level character "S" for Commercial, or "X" for non-standard (customer specific)
- (2) Capacitance tolerance character "K" or "M"
- (3) Lead style character "N", "L", "M", "J" or "K"

Table 1C – Commercial/Non-Standard – Product Selection 630VDC-1000VDC con't.

Commercial/Non-Standard – Customer Specific Unencapsulated, Horizontally Stacked					
KEMET P/N ¹	Cap (μF)	Case Code	Height A inch (mm)	Cap Tolerance	Lead Config.
L1W(1)50B124(2)(3)12	0.12	5	0.120 (3.05)	K, M	N, L, M, J, K
L1W(1)50B154(2)(3)12	0.15	5	0.120 (3.05)	K, M	N, L, M, J, K
L1W(1)50B184(2)(3)24	0.18	5	0.240 (6.10)	K, M	N, L, M, J, K
L1W(1)30B224(2)(3)12	0.22	3	0.120 (3.05)	K, M	N, L, M, J, K
L1W(1)40B224(2)(3)12	0.22	4	0.120 (3.05)	K, M	N, L, M, J, K
L1W(1)50B224(2)(3)24	0.22	5	0.240 (6.10)	K, M	N, L, M, J, K
L1W(1)50B274(2)(3)24	0.27	5	0.240 (6.10)	K, M	N, L, M, J, K
L1W(1)30B334(2)(3)12	0.33	3	0.120 (3.05)	K, M	N, L, M, J, K
L1W(1)50B334(2)(3)36	0.33	5	0.360 (9.14)	K, M	N, L, M, J, K
L1W(1)40B394(2)(3)12	0.39	4	0.120 (3.05)	K, M	N, L, M, J, K
L1W(1)50B394(2)(3)36	0.39	5	0.360 (9.14)	K, M	N, L, M, J, K
L1W(1)30B474(2)(3)12	0.47	3	0.120 (3.05)	K, M	N, L, M, J, K
L1W(1)40B474(2)(3)24	0.47	4	0.240 (6.10)	K, M	N, L, M, J, K
L1W(1)50B474(2)(3)36	0.47	5	0.360 (9.14)	K, M	N, L, M, J, K
L1W(1)50B564(2)(3)48	0.56	5	0.480 (12.19)	K, M	N, L, M, J, K
L1W(1)30B684(2)(3)12	0.68	3	0.120 (3.05)	K, M	N, L, M, J, K
L1W(1)40B684(2)(3)24	0.68	4	0.240 (6.10)	K, M	N, L, M, J, K
L1W(1)50B684(2)(3)65	0.68	5	0.650 (16.51)	K, M	N, L, M, J, K
L1W(1)50B754(2)(3)65	0.75	5	0.650 (16.51)	K, M	N, L, M, J, K
L1W(1)40B824(2)(3)24	0.82	4	0.240 (6.10)	K, M	N, L, M, J, K
L1W(1)30B105(2)(3)12	1	3	0.120 (3.05)	K, M	N, L, M, J, K
L1W(1)40B105(2)(3)36	1	4	0.360 (9.14)	K, M	N, L, M, J, K
L1W(1)30B125(2)(3)12	1.2	3	0.120 (3.05)	K, M	N, L, M, J, K
L1W(1)40B125(2)(3)36	1.2	4	0.360 (9.14)	K, M	N, L, M, J, K
L1W(1)30B155(2)(3)12	1.5	3	0.120 (3.05)	K, M	N, L, M, J, K
L1W(1)40B155(2)(3)48	1.5	4	0.480 (12.19)	K, M	N, L, M, J, K
L1W(1)40B185(2)(3)48	1.8	4	0.480 (12.19)	K, M	N, L, M, J, K
L1W(1)30B225(2)(3)24	2.2	3	0.240 (6.10)	K, M	N, L, M, J, K
L1W(1)40B225(2)(3)65	2.2	4	0.650 (16.51)	K, M	N, L, M, J, K
L1W(1)30B245(2)(3)24	2.4	3	0.240 (6.10)	K, M	N, L, M, J, K
L1W(1)30B275(2)(3)24	2.7	3	0.240 (6.10)	K, M	N, L, M, J, K
L1W(1)30B335(2)(3)36	3.3	3	0.360 (9.14)	K, M	N, L, M, J, K
L1W(1)30B365(2)(3)36	3.6	3	0.360 (9.14)	K, M	N, L, M, J, K
L1W(1)30B395(2)(3)36	3.9	3	0.360 (9.14)	K, M	N, L, M, J, K
L1W(1)30B475(2)(3)36	4.7	3	0.360 (9.14)	K, M	N, L, M, J, K
L1W(1)30B565(2)(3)48	5.6	3	0.480 (12.19)	K, M	N, L, M, J, K
L1W(1)30B605(2)(3)65	6	3	0.650 (16.51)	K, M	N, L, M, J, K
L1W(1)30B685(2)(3)65	6.8	3	0.650 (16.51)	K, M	N, L, M, J, K
1000VDC - X7R Dielectric					
L1W(1)50D473(2)(3)12	0.047	5	0.120 (3.05)	K, M	N, L, M, J, K
L1W(1)50D683(2)(3)12	0.068	5	0.120 (3.05)	K, M	N, L, M, J, K
L1W(1)30D104(2)(3)12	0.1	3	0.120 (3.05)	K, M	N, L, M, J, K
L1W(1)40D104(2)(3)12	0.1	4	0.120 (3.05)	K, M	N, L, M, J, K
L1W(1)50D104(2)(3)24	0.1	5	0.240 (6.10)	K, M	N, L, M, J, K
L1W(1)50D124(2)(3)24	0.12	5	0.240 (6.10)	K, M	N, L, M, J, K
L1W(1)50D154(2)(3)36	0.15	5	0.360 (9.14)	K, M	N, L, M, J, K
L1W(1)50D184(2)(3)36	0.18	5	0.360 (9.14)	K, M	N, L, M, J, K
L1W(1)30D224(2)(3)12	0.22	3	0.120 (3.05)	K, M	N, L, M, J, K
L1W(1)40D224(2)(3)12	0.22	4	0.120 (3.05)	K, M	N, L, M, J, K
L1W(1)50D224(2)(3)36	0.22	5	0.360 (9.14)	K, M	N, L, M, J, K
L1W(1)50D274(2)(3)48	0.27	5	0.480 (12.19)	K, M	N, L, M, J, K
L1W(1)30D334(2)(3)12	0.33	3	0.120 (3.05)	K, M	N, L, M, J, K
L1W(1)50D334(2)(3)65	0.33	5	0.650 (16.51)	K, M	N, L, M, J, K
KEMET P/N ¹	Cap (μF)	Case Code	Height A inch (mm)	Cap Tolerance	Lead Config.

¹ Complete part number requires additional characters in the numbered positions provided in order to indicate product level (B level or T level), capacitance tolerance and lead configuration. For each numbered position, available options are as follows:

- (1) Test Level character "S" for Commercial, or "X" for non-standard (customer specific)
- (2) Capacitance tolerance character "K" or "M"
- (3) Lead style character "N", "L", "M", "J" or "K"

Table 1C – Commercial/Non-Standard – Product Selection 1000VDC con't.

Commercial/Non-Standard – Customer Specific Unencapsulated, Horizontally Stacked					
KEMET P/N ¹	Cap (μF)	Case Code	Height A inch (mm)	Cap Tolerance	Lead Config.
L1W(1)40D394(2)(3)24	0.39	4	0.240 (6.10)	K, M	N, L, M, J, K
L1W(1)50D394(2)(3)65	0.39	5	0.650 (16.51)	K, M	N, L, M, J, K
L1W(1)30D474(2)(3)12	0.47	3	0.120 (3.05)	K, M	N, L, M, J, K
L1W(1)40D474(2)(3)24	0.47	4	0.240 (6.10)	K, M	N, L, M, J, K
L1W(1)30D684(2)(3)12	0.68	3	0.120 (3.05)	K, M	N, L, M, J, K
L1W(1)40D684(2)(3)36	0.68	4	0.360 (9.14)	K, M	N, L, M, J, K
L1W(1)40D824(2)(3)48	0.82	4	0.480 (12.19)	K, M	N, L, M, J, K
L1W(1)30D105(2)(3)24	1	3	0.240 (6.10)	K, M	N, L, M, J, K
L1W(1)40D105(2)(3)65	1	4	0.650 (16.51)	K, M	N, L, M, J, K
L1W(1)30D125(2)(3)24	1.2	3	0.240 (6.10)	K, M	N, L, M, J, K
L1W(1)30D155(2)(3)36	1.5	3	0.360 (9.14)	K, M	N, L, M, J, K
L1W(1)30D225(2)(3)36	2.2	3	0.360 (9.14)	K, M	N, L, M, J, K
L1W(1)30D245(2)(3)48	2.4	3	0.480 (12.19)	K, M	N, L, M, J, K
L1W(1)30D275(2)(3)48	2.7	3	0.480 (12.19)	K, M	N, L, M, J, K
L1W(1)30D335(2)(3)65	3.3	3	0.650 (16.51)	K, M	N, L, M, J, K
KEMET P/N ¹	Cap (μF)	Case Code	Height A inch (mm)	Cap Tolerance	Lead Config.

¹ Complete part number requires additional characters in the numbered positions provided in order to indicate product level (B level or T level), capacitance tolerance and lead configuration. For each numbered position, available options are as follows:

- (1) Test Level character "S" for Commercial, or "X" for non-standard (customer specific)
- (2) Capacitance tolerance character "K" or "M"
- (3) Lead style character "N", "L", "M", "J" or "K"

Soldering Process

The capacitors and assemblies outlined in this specification sheet are susceptible to thermal shock damage due to their large ceramic mass. Temperature profiles used should provide adequate temperature rise and cool-down time to prevent damage from thermal shock. In general, KEMET recommends against hand soldering for these types of large ceramic devices.

Recommended Soldering Technique:

- Solder reflow only

Recommended Reflow Soldering Profile:

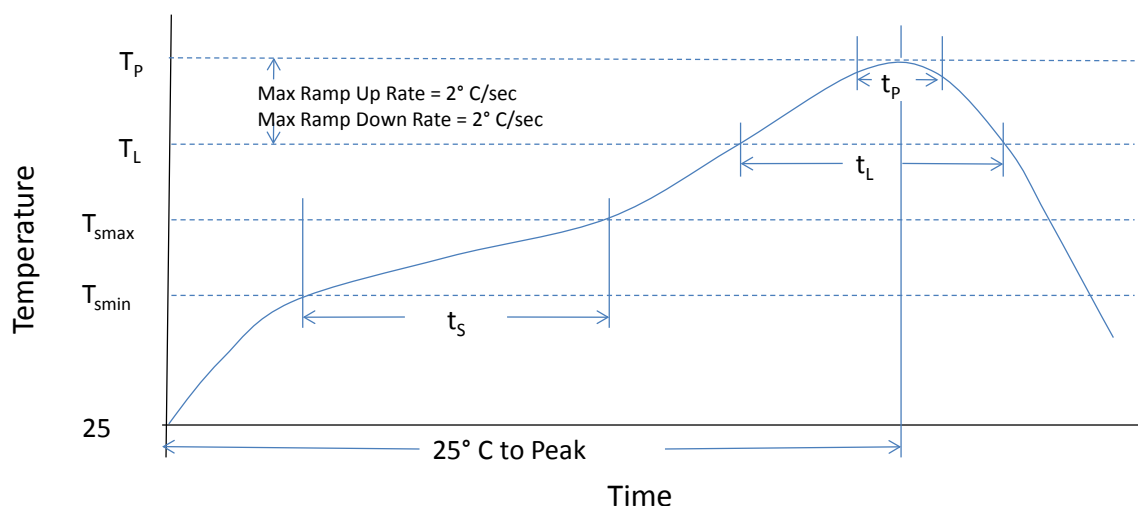

Profile Feature	Sn-Pb Assembly
Preheat/Soak	
Temperature Min (T_{smin})	100°C
Temperature Max (T_{smax})	150°C
Time (t_s) from T_{smin} to T_{smax}	60-90 sec
Ramp-up rate (T_L to T_P)	2°C/sec
Liquidous temperature (T_L)	183°C
Time above liquidous (t_L)	95 sec
Peak Temperature (T_P)	240°C
Time within 5° C of max peak temperature (t_p)	5 sec
Ramp-down rate (T_P to T_L)	2°C/sec
Time 25° C to peak temperature	3.5 minutes

Note 1: All temperatures refer to the center of the package, measured on the package body surface that is facing up during assembly reflow

Preheating and Reflow Profile Notes:

Due to differences in the coefficient of thermal expansion for the different materials of construction, it is critical to monitor and control the heating and cooling rates during the soldering process. During the reflow soldering process, the maximum recommended heating and cooling rate (dT/dt) is 4°C/second. To ensure optimal component reliability, KEMET's recommended heating and cooling rate is 2°C/second. After soldering, the capacitors should be air cooled to room temperature before further processing. Forced air cooling is not recommended.

Table 4 – Performance & Reliability: Test Methods and Conditions

Inspection	Test Method	Test Level Option				
		MIL-PRF-49470 B Level (B)	MIL-PRF-49470 T Level (T)	DSSC Drawing 87106 (C) ¹	Commercial (S)	Non-Standard (X) ²
In-Process Inspection						
Ultrasonic Scanning (C-SAM)	Meet EIA-469 Criteria	Not required	Yes (per lot)	Not required	Not required	Optional per Source Controlled Drawing (SCD)
DPA Analysis	EIA-469					
In-Process Visual Inspection	MIL-PRF-49470 Method 4.8.3					
Group A Requirements						
Thermal Shock	MIL-STD-202 Method 107	Yes (5 cycles)	Yes (20 cycles)	Yes (5 cycles)	Not required	Optional per Source Controlled Drawing (SCD)
Voltage Conditioning ≤200V 500V	MIL-PRF-49470 Method 4.8.5.2 200%Vr @125°C 120%Vr @125°C	Yes (96 hrs min.)	Yes (168 hrs min.)	Yes (96 hrs min.)		
Visual and Mechanical Inspection	MIL-PRF-49470 Method 4.8.4	Yes (per lot)	Yes (per lot)	Yes (per lot)		Yes (per lot)
Solderability	MIL-STD-202 Method 208	Yes (per Inspection lot)		Yes (per inspection lot)		Optional per Source Controlled Drawing (SCD)
DPA Analysis	EIA-469	Not required		Not required		
Group B Requirements						
Voltage-Temperature Limits (TCVC)	MIL-PRF-49470 Method 4.8.13.2	Yes (periodic)	Yes (per lot)	Yes (periodic)	Not required	Optional per Source Controlled Drawing (SCD)
Resistance to Solvents	MIL-STD-202 Method 215					
Terminal Strength	MIL-STD-202 Method 211					
Resistance to Soldering Heat	MIL-STD-202 Method 210					
Moisture Resistance	MIL-STD-202 Method 106					
Marking Legibility	MIL-PRF-49470 Method 4.8.4.1	Not required	Yes (per lot)	Yes (periodic)	Not required	
Low Voltage Humidity Testing	MIL-STD-202 Method 103					
Life Test ≤200V 500V	MIL-STD-202 Method 108 200%Vr @125°C 120%Vr @125°C					
Thermal Shock	MIL-STD-202 Method 107	Not required	Not required	Not required	Not required	
KEMET Requirements						
Visual and Mechanical Inspection (100%)	KEMET Standard	Yes	Yes	Yes	Yes	Yes
Voltage Conditioning						

¹ As per discretionary statement outlined in cancelled DSSC Drawing 87106, KEMET will not perform Group B inspections on a per lot basis. KEMET 87106 orders may include a standard certificate of compliance stating compliance to the 87106 requirements, specifically conformance to Group B inspections. Please contact KEMET for additional details

² Non-standard test level option is designated to satisfy customer specific testing requirements that may deviate from those stated in a Mil-Spec or DSSC drawing.

Product Marking

Capacitors shall be marked with KEMET's name, trademark or (CAGE) code, date, capacitance and capacitance tolerance codes. The date code shall consist of the year and week. For example, the third week of 2011 would be 1103 using a 4-digit date code or 103 using a 3-digit date code. At the option of the manufacturer, the date code may be placed on a separate line. Full marking shall be included on the package.

JT
12345
106K
1103

Case code 4 or 5 example

MIL-PRF-49470

Capacitor marking will include "JAN" or "J."

Case codes 4 and 5 shall be marked with the following sequence of information:

J brand (1 digit), product level designator ("B" or "T")

Manufacturer's identification (1 to 5 digits)

Capacitance code (3 digits) and capacitance tolerance (1 digit)

Date code (3 or 4 digits)

Case code 3 shall either be fully marked or partially marked like case code 4 or 5 parts at the option of KEMET.

DSCC 87106

Marking shall be in accordance with MIL-STD-1285, except the parts shall be marked with the part number as specified in paragraph 1.2 of DSCC Drawing 87106 with the manufacturer's name or code and date code minimum. Case sizes 4 and 5 shall be marked with coded capacitance and tolerance minimum. Full marking shall be included on the package.

Storage and Handling

Ceramic chip capacitors should be stored in normal working environments. While the chips themselves are quite robust in other environments, solderability will be degraded by exposure to high temperatures, high humidity, corrosive atmospheres, and long term storage. In addition, packaging materials will be degraded by high temperature – reels may soften or warp, and tape peel force may increase. KEMET recommends that maximum storage temperature not exceed 40 degrees C, and maximum storage humidity not exceed 70% relative humidity. In addition, temperature fluctuations should be minimized to avoid condensation on the parts, and atmospheres should be free of chlorine and sulfur bearing compounds. For optimized solderability, chip stock should be used promptly, preferably within 1.5 years of receipt.

Packaging

Shipping Container Packaging Quantities		
Case Code	Small Box Quantity ¹ (7.5" x 7.5")	Large Box Quantity ¹ (13.0" x 13.0")
3	28	104
4	36	144
5	64	225

¹ Minimum order value applies. Contact KEMET for details.

Application Notes

Notice of KEMET MIL-PRF-49470 Qualified Products Listing (QPL) Status.

KEMET is qualified to supply MIL-PRF-49470/1 unencapsulated X7R Case Codes 3, 4, & 5 ceramic SMPS capacitors in DC voltage ratings of 50V, 100V, 200V, and 500V. This qualification includes both "B" and "T" test levels.

KEMET is also qualified to supply MIL-PRF-49470/2 encapsulated X7R Case Codes 3, 4, & 5 ceramic SMPS capacitors in DC voltage ratings of 50V, 100V, 200V, and 500V. This qualification includes "B" level testing only.

Notice of Cancellation: DSCC Drawing 87106 was cancelled on January 3rd 2005.

MIL-PRF-49470 parts are preferred and direct replacements.

MIL-PRF-49470 capacitors are preferred over DSCC 87106 capacitors. The MIL-PRF-49470 specification was developed as part of a cooperative effort between the U.S. Military, NASA and the switch mode power supply capacitor manufacturers to produce a robust direct replacement for the DSCC drawing. The military specification product provides additional quality assurance provisions that are NOT required by the DSCC drawing. Two product levels are offered in MIL-PRF-49470: the standard "B" level and the high reliability "T" level. Some of the benefits of the MIL-PRF-49470 product over the 87106 product include the following: Formal qualification process (QPL established), MIL-STD-790 compliance, DSCC audits, routine qualification maintenance testing, i.e., life testing, group A percent defective allowed (PDA) specified, and prohibiting the mixing of chips from different production lots within a single SMPS capacitor stack lot.

MIL-PRF-49470 "T" Level product is recommended for all high reliability applications. MIL-PRF-49470 "T" level product requires the following in-process inspections and additional group A and B screening inspections that are not part of the normal "B" level flow: In-process screening that includes non-destructive internal examination (chip level) and destructive physical analysis (chip level), group A destructive physical analysis (finished stack level), group B lot specific humidity, steady-state, low voltage (lot sample test), and group B lot specific thermal shock & life test (lot sample test).

For additional information regarding KEMET MIL-PRF-49470 QPL status or cancellation of DSCC Drawing 87106, please visit the DSCC website at: www.dscc.dla.mil.

High Temperature 150°C, Ultra-Stable X8R Dielectric, 25VDC-100VDC (Commercial & Automotive Grade)

Overview

KEMET's Ultra-Stable X8R dielectric features a 150°C maximum operating temperature, offering the latest in high temperature dielectric technology and reliability for extreme temperature applications. It offers the same temperature capability as conventional X8R, but without the capacitance loss due to applied DC voltage. Ultra-Stable X8R exhibits no change in capacitance with respect to voltage and boasts a minimal change in capacitance with reference to ambient temperature. It is a suitable replacement for higher capacitance and larger footprint devices that fail to offer capacitance stability. Capacitance change with respect to temperature is limited to $\pm 15\%$ from -55°C to +150°C.

Driven by the demand for a more robust and reliable component, Ultra-Stable X8R dielectric capacitors were developed for critical applications where reliability and capacitance stability at higher operating temperatures are a concern. These capacitors are manufactured in state of the art ISO/TS 16949:2002 certified facilities and are widely used in automotive circuits as well as general high temperature applications.

In addition to commercial grade, automotive grade devices are available and meet the demanding Automotive Electronics Council's AEC-Q200 qualification requirements.

Benefits

- -55°C to +150°C operating temperature range
- Pb-Free and RoHS compliant
- EIA 0402, 0603, 0805, 1206, 1210 and 1812 case sizes
- DC voltage ratings of 25V, 50V and 100V
- Capacitance offerings ranging from 10pF to 0.22 μ F
- Available capacitance tolerances of $\pm 1\%$, $\pm 2\%$, $\pm 5\%$, $\pm 10\%$ and $\pm 20\%$,
- Extremely low ESR and ESL
- High thermal stability
- High ripple current capability
- No capacitance change with respect to applied rated DC voltage
- Non-polar device, minimizing installation concerns
- Offered in both commercial and automotive grades
- 100% pure matte tin-plated termination finish that allowing for excellent solderability.
- SnPb plated termination finish option available upon request (5% min)

Applications

Typical applications include decoupling, bypass and filtering in extreme environments such as down-hole oil exploration, under-hood automotive, military and aerospace.

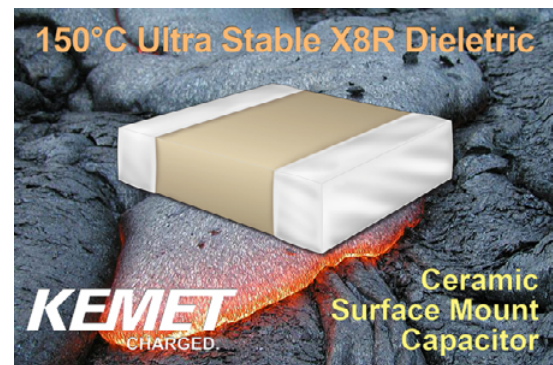

Ordering Information

C	1210	C	184	K	3	H	A	C	AUTO
Ceramic	Case Size (L" x W")	Specification/ Series	Capacitance Code (pF)	Capacitance Tolerance	Voltage	Dielectric	Failure Rate/ Design	Termination Finish ¹	Packaging/Grade (C-Spec) ²
	0402 0603 0805 1206 1210 1812	C = Standard	2 Sig. Digits + Number of Zeros	F = $\pm 1\%$ G = $\pm 2\%$ J = $\pm 5\%$ K = $\pm 10\%$ M = $\pm 20\%$	3 = 25V 5 = 50V 1 = 100V	H = Ultra Stable X8R	A = N/A	C = 100% Matte Sn L = SnPb (5% min)	Blank = Bulk TU = 7" Reel Unmarked AUTO = Automotive Grade 7" Reel Unmarked

¹ Additional termination finish options may be available. Contact KEMET for details.

² Additional reeling or packaging options may be available. Contact KEMET for details.

Dimensions – Millimeters (Inches)

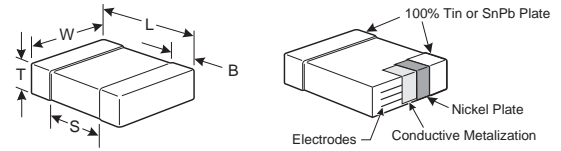

EIA Size Code	Metric Size Code	L Length	W Width	T Thickness	B Bandwidth	S Separation Min.	Mounting Technique
0402	1005	1.00 (.040) ± 0.05 (.002)	0.50 (.020) ± 0.05 (.002)	See Table 2 for Thickness	0.30 (.012) ± 0.10 (.004)	0.30 (.012)	Solder Reflow Only
0603	1608	1.60 (.063) ± 0.15 (.006)	0.80 (.032) ± 0.15 (.006)		0.35 (.014) ± 0.15 (.006)	0.70 (.028)	Solder Wave or Solder Reflow
0805	2012	2.00 (.079) ± 0.20 (.008)	1.25 (.049) ± 0.20 (.008)		0.50 (0.02) ± 0.25 (.010)	0.75 (.030)	
1206	3216	3.20 (.126) ± 0.20 (.008)	1.60 (.063) ± 0.20 (.008)		0.50 (0.02) ± 0.25 (.010)	N/A	Solder Reflow Only
1210	3225	3.20 (.126) ± 0.20 (.008)	2.50 (.098) ± 0.20 (.008)		0.50 (0.02) ± 0.25 (.010)		
1812	4532	4.50 (.177) ± 0.30 (.012)	3.20 (.126) ± 0.30 (.012)		0.60 (.024) ± 0.35 (.014)		

Qualification/Certification

Commercial grade products are subject to internal qualification. Details regarding test methods and conditions are referenced in Table 4, Performance and Reliability.

Automotive grade products meet or exceed the requirements outlined by the Automotive Electronics Council. Details regarding test methods and conditions are referenced in document AEC-Q200, Stress Test Qualification for Passive Components. For additional information regarding the Automotive Electronics Council and AEC-Q200, please visit their website @www.aecouncil.com.

Environmental Compliance

Pb-Free and RoHS compliant (excluding SnPb termination finish option)

Electrical Parameters/Characteristics

Item	Parameters/Characteristics
Operating Temperature Range	-55°C to +150°C
Capacitance Change with Reference to +25°C and 0 Vdc Applied (TCC)	±15%
Aging Rate (Max % Cap Loss/Decade Hour)	0%
Dielectric Withstanding Voltage	250% of rated voltage (5 ± 1 seconds and charge/discharge not exceeding 50mA)
Dissipation Factor (DF) Maximum Limits @ 25°C	2.5%
Insulation Resistance (IR) Limit @ 25°C	1000 megohm microfarads or 100GΩ (Rated voltage applied for 120 ± 5 secs @ 25°C)

To obtain IR limit, divide MΩ-μF value by the capacitance and compare to GΩ limit. Select the lower of the two limits.

Capacitance and Dissipation Factor (DF) measured under the following conditions:

1MHz ± 100kHz and 1.0 ± 0.2 Vrms if capacitance ≤ 1000pF.

1kHz ± 50Hz and 1.0 ± 0.2 Vrms if capacitance > 1000pF

Note: When measuring capacitance it is important to ensure the set voltage level is held constant. The HP4284 & Agilent E4980 have a feature known as Automatic Level Control (ALC). The ALC feature should be switched to "ON".

Post Environmental Limits

High Temperature Life, Biased Humidity, Moisture Resistance					
Dielectric	Rated DC Voltage	Capacitance Value	DF (%)	Cap Shift	IR
Ultra Stable X8R	All	All	2.5	0.3% or ± 0.25 pf	10% of Initial Limit

Table 1 – X8R Dielectric, (0402 - 1812 Case Sizes)

Cap	Cap Code	Series					C0402			C0603			C0805			C1206			C1210			C1812	
		Voltage Code					3	5	1	3	5	1	3	5	1	3	5	1	3	5	1	5	1
		Voltage DC					25	50	100	25	50	100	25	50	100	25	50	100	25	50	100	50	100
		Cap Tolerance					Product Availability and Chip Thickness Codes See Table 2 for Chip Thickness Dimensions																
100 pF	101	F	G	J	K	M	BB	BB	BB														
110 pF	111	F	G	J	K	M	BB	BB	BB														
120 pF	121	F	G	J	K	M	BB	BB	BB														
130 pF	131	F	G	J	K	M	BB	BB	BB														
150 pF	151	F	G	J	K	M	BB	BB	BB														
160 pF	161	F	G	J	K	M	BB	BB	BB														
180 pF	181	F	G	J	K	M	BB	BB	BB														
200 pF	201	F	G	J	K	M	BB	BB	BB														
220 pF	221	F	G	J	K	M	BB	BB	BB														
240 pF	241	F	G	J	K	M	BB	BB	BB														
270 pF	271	F	G	J	K	M	BB	BB	BB														
300 pF	301	F	G	J	K	M	BB	BB	BB														
330 pF	331	F	G	J	K	M	BB	BB	BB														
360 pF	361	F	G	J	K	M	BB	BB	BB														
390 pF	391	F	G	J	K	M	BB	BB	BB														
430 pF	431	F	G	J	K	M	BB	BB	BB	CB	CB	CB											
470 pF	471	F	G	J	K	M	BB	BB	BB	CB	CB	CB											
510 pF	511	F	G	J	K	M	BB	BB	BB	CB	CB	CB											
560 pF	561	F	G	J	K	M	BB	BB	BB	CB	CB	CB											
620 pF	621	F	G	J	K	M	BB	BB	BB	CB	CB	CB											
680 pF	681	F	G	J	K	M	BB	BB	BB	CB	CB	CB											
750 pF	751	F	G	J	K	M	BB	BB	BB	CB	CB	CB											
820 pF	821	F	G	J	K	M	BB	BB	BB	CB	CB	CB											
910 pF	911	F	G	J	K	M	BB	BB	BB	CB	CB	CB											
1,000 pF	102	F	G	J	K	M	BB	BB	BB	CB	CB	CB											
1,100 pF	112	F	G	J	K	M	BB	BB		CB	CB	CB											
1,200 pF	122	F	G	J	K	M	BB	BB		CB	CB	CB											
1,300 pF	132	F	G	J	K	M	BB	BB		CB	CB	CB											
1,500 pF	152	F	G	J	K	M	BB	BB		CB	CB	CB											
1,600 pF	162	F	G	J	K	M				CB	CB	CB											
1,800 pF	182	F	G	J	K	M				CB	CB	CB											
2,000 pF	202	F	G	J	K	M				CB	CB	CB											
2,200 pF	222	F	G	J	K	M				CB	CB	CB	DC	DC	DC								
2,400 pF	242	F	G	J	K	M				CB	CB	CB	DC	DC	DC								
2,700 pF	272	F	G	J	K	M				CB	CB	CB	DC	DC	DC								
3,000 pF	302	F	G	J	K	M				CB	CB	CB	DC	DC	DC								
3,300 pF	332	F	G	J	K	M				CB	CB	CB	DC	DC	DC								
3,600 pF	362	F	G	J	K	M				CB	CB	CB	DC	DC	DC								
3,900 pF	392	F	G	J	K	M				CB	CB	CB	DC	DC	DC								
4,300 pF	432	F	G	J	K	M				CB	CB	CB	DC	DC	DC								
4,700 pF	472	F	G	J	K	M				CB	CB	CB	DC	DC	DC								
5,100 pF	512	F	G	J	K	M				CB	CB		DC	DC	DC								
5,600 pF	562	F	G	J	K	M				CB	CB		DC	DC	DC								
6,200 pF	622	F	G	J	K	M				CB	CB		DC	DC	DC								
6,800 pF	682	F	G	J	K	M				CB	CB		DC	DC	DC	EB	EB	EB					
7,500 pF	752	F	G	J	K	M				CB			DC	DC	DC	EB	EB	EB					
8,200 pF	822	F	G	J	K	M				CB			DC	DC	DC	EB	EB	EB					
9,100 pF	912	F	G	J	K	M				CB			DC	DC	DC	EB	EB	EB					
10,000 pF	103	F	G	J	K	M				CB			DC	DC	DD	EB	EB	EB					
12,000 pF	123	F	G	J	K	M							DC	DC	DE	EB	EB	EB	FB	FB	FB		
15,000 pF	153	F	G	J	K	M							DC	DD	DG	EB	EB	EB	FB	FB	FB	GB	GB
18,000 pF	183	F	G	J	K	M							DC	DD		EB	EB	EB	FB	FB	FB	GB	GB
22,000 pF	223	F	G	J	K	M							DD	DF		EB	EB	EC	FB	FB	FB	GB	GB
27,000 pF	273	F	G	J	K	M							DF			EB	EB	EE	FB	FB	FB	GB	GB
33,000 pF	333	F	G	J	K	M							DG			EB	EB	EE	FB	FB	FB	GB	GB
47,000 pF	473	F	G	J	K	M										EC	EE	EH	FB	FB	FE	GB	GB
56,000 pF	563	F	G	J	K	M										ED	EF	EH	FB	FB	FF	GB	GB
Cap	Cap Code	Voltage DC					25	50	100	25	50	100	25	50	100	25	50	100	25	50	100	50	100
		Voltage Code					3	5	1	3	5	1	3	5	1	3	5	1	3	5	1	5	1
		Series					C0402			C0603			C0805			C1206			C1210			C1812	

Table 1 – X8R Dielectric, (0402 - 1812 Case Sizes) con't

Cap	Cap Code	Series					C0402			C0603			C0805			C1206			C1210			C1812	
		Voltage Code					3	5	1	3	5	1	3	5	1	3	5	1	3	5	1	5	1
		Voltage DC					25	50	100	25	50	100	25	50	100	25	50	100	25	50	100	50	100
		Cap Tolerance					Product Availability and Chip Thickness Codes See Table 2 for Chip Thickness Dimensions																
68,000 pF	683	F	G	J	K	M										EF	EH		FB	FC	FG	GB	GB
82,000 pF	823	F	G	J	K	M										EH	EH		FC	FF	FH	GB	GB
100,000 pF	104	F	G	J	K	M										EH			FE	FG	FM	GB	GD
120,000 pF	124	F	G	J	K	M													FG	FH		GB	GH
150,000 pF	154	F	G	J	K	M													FH	FM		GD	GN
180,000 pF	184	F	G	J	K	M													FJ			GH	
220,000 pF	224	F	G	J	K	M																GK	
Cap	Cap Code	Voltage DC					25	50	100	25	50	100	25	50	100	25	50	100	25	50	100	50	100
		Voltage Code					3	5	1	3	5	1	3	5	1	3	5	1	3	5	1	5	1
		Series					C0402			C0603			C0805			C1206			C1210			C1812	

High Temperature 150°C, X8L Dielectric, 10VDC-50VDC (Commercial & Automotive Grade)

Overview

KEMET's X8L dielectric features a 150°C maximum operating temperature and is considered "general purpose high temperature." These components are fixed, ceramic dielectric capacitors suited for high temperature bypass and decoupling applications or frequency discriminating circuits where Q and stability of capacitance characteristics are not critical. X8L exhibits a predictable change in capacitance with respect to time and voltage and boasts a minimal change in capacitance with reference to ambient temperature up to 125°C. Beyond 125°C X8L displays a wider variation in capacitance. Capacitance change is limited to ±15% from -55°C to +125°C and +15, -40% from 125°C to 150°C.

Driven by the demand for a more robust and reliable component, X8L dielectric capacitors were developed for critical applications where reliability at higher operating temperatures are a concern. These capacitors are manufactured in state of the art ISO/TS

16949:2002 certified facilities and are widely used in automotive circuits as well as general high temperature applications.

Concerned with flex cracks resulting from excessive shear stresses produced during board flexure or thermal cycling? These devices are available with KEMET's Flexible termination technology which directs board flex stress away from the ceramic body and into the termination area, therefore mitigating flex cracks which can result in low IR or short circuit failures. Although flexible termination technology does not eliminate the potential for mechanical damage that may propagate during extreme environmental and handling conditions, it does provide superior flex performance over standard termination systems.

In addition to commercial grade, automotive grade devices are available and meet the demanding Automotive Electronics Council's AEC-Q200 qualification requirements.

Benefits

- -55°C to +150°C operating temperature range
- Pb-Free & RoHS compliant
- EIA 0402, 0603, 0805, 1206 & 1210 case sizes
- DC voltage ratings of 10V, 25V & 50V
- Capacitance offerings ranging from .012µF to 10µF
- Available capacitance tolerances of ±5%, ±10% & ±20%
- Commercial & Automotive (AEC-Q200) grades available
- Non-polar device, minimizing installation concerns

- 100% pure matte tin-plated termination finish allowing for excellent solderability
- SnPb termination finish option available upon request (5% min)
- Flexible termination option available upon request

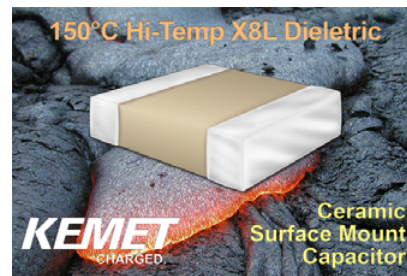

Ordering Information

C	1210	X	106	K	8	N	A	C	TU
Ceramic	Case Size (L" x W")	Specification/ Series ¹	Capacitance Code (pF)	Capacitance Tolerance	Voltage	Dielectric	Failure Rate/ Design	Termination Finish ²	Packaging/Grade (C-Spec) ³
	0402 0603 0805 1206 1210	C = Standard X = Flexible Termination	2 Sig. Digits + Number of Zeros	J = ±5% K = ±10% M = ±20%	8 = 10V 3 = 25V 5 = 50V	N = X8L	A = N/A	C = 100% Matte Sn L = SnPb (5% min)	Blank = Bulk TU = 7" Reel Unmarked TM = 7" Reel Marked AUTO = Automotive Grade 7" Reel Unmarked

¹ The flexible termination option is not available on EIA 0402 case size product. "C" must be used in the 6th character position when ordering this case size.

² Additional termination finish options may be available. Contact KEMET for details.

^{2,3} SnPb termination finish option is not available on automotive grade product.

³ Additional reeling or packaging options may be available. Contact KEMET for details.

Dimensions – Standard Termination – Millimeters (Inches)

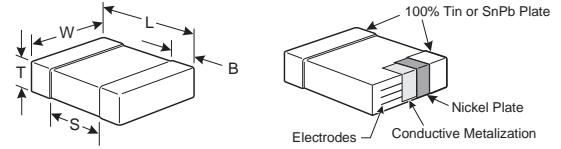

EIA Size Code	Metric Size Code	L Length	W Width	T Thickness	B Bandwidth	S Separation Min.	Mounting Technique
0402	1005	1.00 (.040) ± 0.05 (.002)	0.50 (.020) ± 0.05 (.002)	See Table 2 for Thickness	0.30 (.012) ± 0.10 (.004)	0.30 (.012)	Solder Reflow Only
0603	1608	1.60 (.063) ± 0.15 (.006)	0.80 (.032) ± 0.15 (.006)		0.35 (.014) ± 0.15 (.006)	0.70 (.028)	Solder Wave or Solder Reflow
0805	2012	2.00 (.079) ± 0.20 (.008)	1.25 (.049) ± 0.20 (.008)		0.50 (0.02) ± 0.25 (.010)	0.75 (.030)	
1206	3216	3.20 (.126) ± 0.20 (.008)	1.60 (.063) ± 0.20 (.008)		0.50 (0.02) ± 0.25 (.010)	N/A	Solder Reflow Only
1210	3225	3.20 (.126) ± 0.20 (.008)	2.50 (.098) ± 0.20 (.008)		0.50 (0.02) ± 0.25 (.010)		

Dimensions – Flexible Termination – Millimeters (Inches)

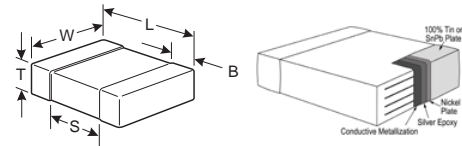

EIA Size Code	Metric Size Code	L Length	W Width	T Thickness	B Bandwidth	S Separation Min.	Mounting Technique
0603	1608	1.60 (.063) +0.20 (.008)/-0.10 (.004)	0.80 (.032) ± 0.15 (.006)	See Table 2 for Thickness	0.45 (.018) +0.05 (.002)/-0.15 (.006)	0.50 (.020)	Solder Wave or Solder Reflow
0805	2012	2.10 (.083) +0.30 (.012)/-0.20 (.008)	1.25 (.049) ± 0.20 (.008)		0.50 (0.02) +0.10 (.004)/-0.25 (.010)	0.70 (.028)	
1206	3216	3.30 (.130) ± 0.40 (.016)	1.60 (.063) ± 0.20 (.008)		0.60 (.024) ± 0.25 (.010)	N/A	Solder Reflow Only
1210	3225	3.30 (.130) ± 0.40 (.016)	2.50 (.098) ± 0.20 (.008)		0.60 (.024) ± 0.25 (.010)		

Applications

Typical applications include use in extreme environments such as down-hole oil exploration, under-hood automotive, military and aerospace.

Qualification/Certification

Commercial grade products are subject to internal qualification. Details regarding test methods and conditions are referenced in Table 4, Performance and Reliability.

Automotive grade products meet or exceed the requirements outlined by the Automotive Electronics Council. Details regarding test methods and conditions are referenced in document AEC-Q200, Stress Test Qualification for Passive Components. For additional information regarding the Automotive Electronics Council and AEC-Q200, please visit their website at www.aecouncil.com.

Environmental Compliance

Pb-Free and RoHS compliant (excluding SnPb termination finish option).

Electrical Parameters/Characteristics

Item	Parameters/Characteristics
Operating Temperature Range	-55°C to +150°C
Capacitance Change with Reference to +25°C and 0 Vdc Applied (TCC)	±15% (-55°C–125°C) +15, -40% (125°C–150°C)
Aging Rate (Max % Cap Loss/Decade Hour)	3.0%
Dielectric Withstanding Voltage	250% of rated voltage (5 ± 1 seconds and charge/discharge not exceeding 50mA)
Dissipation Factor (DF) Maximum Limits @ 25°C	3.5% (10V) and 2.5% (25V & 50V)
Insulation Resistance (IR) Limit @ 25°C	500 megohm microfarads or 10GΩ (Rated voltage applied for 120 ± 5 secs @ 25°C)

Regarding Aging Rate: Capacitance measurements (including tolerance) are indexed to a referee time of 1000 hours.

To obtain IR limit, divide $M\Omega\text{-}\mu F$ value by the capacitance and compare to $G\Omega$ limit. Select the lower of the two limits.

Capacitance and Dissipation Factor (DF) measured under the following conditions:

1kHz ± 50Hz and 1.0 ± 0.2 Vrms.

Note: When measuring capacitance it is important to ensure the set voltage level is held constant. The HP4284 & Agilent E4980 have a feature known as Automatic Level Control (ALC). The ALC feature should be switched to "ON."

Post Environmental Limits

High Temperature Life, Biased Humidity, Moisture Resistance					
Dielectric	Rated DC Voltage	Capacitance Value	DF (%)	Cap Shift	IR
X8L	>25	All	3.0	± 20%	10% of Initial Limit
	25		5.0		
	10		7.5		

Table 1 – X8L Dielectric, (0402 - 1210 Case Sizes)

Cap	Cap Code	Series			C0402		C0603			C0805			C1206			C1210		
		Voltage Code			8	3	8	3	5	8	3	5	8	3	5	8	3	5
		Voltage DC			10	25	10	25	50	10	25	50	10	25	50	10	25	50
		Cap Tolerance			Product Availability and Chip Thickness Codes See Table 2 for Chip Thickness Dimensions													
12,000 pF	123	J	K	M	BB	BB												
15,000 pF	153	J	K	M	BB	BB												
18,000 pF	183	J	K	M	BB	BB												
22,000 pF	223	J	K	M	BB	BB												
27,000 pF	273	J	K	M	BB													
33,000 pF	333	J	K	M	BB													
39,000 pF	393	J	K	M	BB													
47,000 pF	473	J	K	M	BB		CB	CB	CB									
56,000 pF	563	J	K	M														
68,000 pF	683	J	K	M														
82,000 pF	823	J	K	M														
0.10 µF	104	J	K	M														
0.12 µF	124	J	K	M			CB	CB										
0.15 µF	154	J	K	M			CB	CB		DG	DG	DG						
0.18 µF	184	J	K	M			CB			DG	DG	DG						
0.22 µF	224	J	K	M			CB			DD	DD	DG						
0.27 µF	274	J	K	M						DD	DD							
0.33 µF	334	J	K	M						DD	DD							
0.39 µF	394	J	K	M						DE	DE			EG	EG	EG	FD	
0.47 µF	474	J	K	M						DE	DE						FD	
0.56 µF	564	J	K	M						DG	DH						FF	
0.68 µF	684	J	K	M						DG	DH						FF	
0.82 µF	824	J	K	M						DG							FG	
1.0 µF	105	J	K	M						DG							FL	
1.2 µF	125	J	K	M									ED	ED			FM	
1.5 µF	155	J	K	M									EH	EH			FM	
1.8 µF	185	J	K	M									EH	EH			FG	
2.2 µF	225	J	K	M									EF	EH			FG	
2.7 µF	275	J	K	M									EF				FG	
3.3 µF	335	J	K	M									EH				FG	
3.9 µF	395	J	K	M									EH				FH	
4.7 µF	475	J	K	M									EH				FM	
5.6 µF	565	J	K	M													FM	
6.8 µF	685	J	K	M													FK	
8.2 µF	825	J	K	M													FS	
10 µF	106	J	K	M													FS	
Cap	Cap Code	Voltage DC			10	25	10	25	50	10	25	50	10	25	50	10	25	50
		Voltage Code			8	3	8	3	5	8	3	5	8	3	5	8	3	5
		Series			C0402			C0603			C0805			C1206			C1210	

Table 2 – Chip Thickness/Packaging Quantities

Thickness Code	Chip Size	Thickness ± Range (mm)	QTY per Reel 7" Plastic	QTY per Reel 13" Plastic	QTY per Reel 7" Paper	QTY per Reel 13" Paper	QTY per Bulk Cassette
AA	1005	0.20 ± 0.02			15000		
AB	0201	0.30 ± 0.03			15000		
BB	0402	0.50 ± 0.05			10000	50000	50000
BC	0402	0.50 ± 0.10			10000	50000	50000
PA	0508	0.80 ± 0.10	4000	10000			
CB	0603	0.80 ± 0.07			4000	10000	15000
CC	0603	0.80 ± 0.10			4000	10000	15000
CD	0603	0.80 ± 0.15			4000	10000	15000
MA	0612	0.80 ± 0.10	4000	10000			
DB	0805	0.60 ± 0.10			4000	10000	15000
DC	0805	0.78 ± 0.10			4000	10000	15000
DD	0805	0.90 ± 0.10			4000	10000	15000
DL	0805	0.95 ± 0.10	4000	10000			
DE	0805	1.00 ± 0.10	2500	10000			
DF	0805	1.10 ± 0.10	2500	10000			
DG	0805	1.25 ± 0.15	2500	10000			
DH	0805	1.25 ± 0.20	2500	10000			
EB	1206	0.78 ± 0.10	4000	10000	4000	10000	
EK	1206	0.80 ± 0.10	2000	8000			
EC	1206	0.90 ± 0.10	4000	10000			
EN	1206	0.95 ± 0.10	4000	10000			
ED	1206	1.00 ± 0.10	2500	10000			
EE	1206	1.10 ± 0.10	2500	10000			
EF	1206	1.20 ± 0.15	2500	10000			
EM	1206	1.25 ± 0.15	2500	10000			
EG	1206	1.60 ± 0.15	2000	8000			
EH	1206	1.60 ± 0.20	2000	8000			
EJ	1206	1.70 ± 0.20	2000	8000			
FB	1210	0.78 ± 0.10	4000	10000			
FC	1210	0.90 ± 0.10	4000	10000			
FD	1210	0.95 ± 0.10	4000	10000			
FE	1210	1.00 ± 0.10	2500	10000			
FF	1210	1.10 ± 0.10	2500	10000			
FG	1210	1.25 ± 0.15	2500	10000			
FL	1210	1.40 ± 0.15	2000	8000			
FO	1210	1.50 ± 0.20	2000	8000			
FH	1210	1.55 ± 0.15	2000	8000			
FP	1210	1.60 ± 0.20	2000	8000			
FM	1210	1.70 ± 0.20	2000	8000			
FJ	1210	1.85 ± 0.20	2000	8000			
FN	1210	1.85 ± 0.20	2000	8000			
FT	1210	1.90 ± 0.20	1500	4000			
FK	1210	2.10 ± 0.20	2000	8000			
FR	1210	2.25 ± 0.20	2000	8000			
FS	1210	2.50 ± 0.20	1000	4000			
FV	1210	3.35 ± 0.10	500	1800			
FW	1210	6.15 ± 0.15	200	1000			
PA	1220	0.80 ± 0.10	4000	10000			
MA	1632	0.80 ± 0.10	4000	10000			
NA	1706	0.90 ± 0.10	4000	10000			
NB	1706	1.00 ± 0.10	4000	10000			
NC	1706	1.00 ± 0.15	4000	10000			
LD	1808	0.90 ± 0.10	2500	10000			
LE	1808	1.00 ± 0.10	2500	10000			
LF	1808	1.00 ± 0.15	2500	10000			
LA	1808	1.40 ± 0.15	1000	4000			
LB	1808	1.60 ± 0.15	1000	4000			
LC	1808	2.00 ± 0.15	1000	4000			
GB	1812	1.00 ± 0.10	1000	4000			
GC	1812	1.10 ± 0.10	1000	4000			
GD	1812	1.25 ± 0.15	1000	4000			
GE	1812	1.30 ± 0.10	1000	4000			
GH	1812	1.40 ± 0.15	1000	4000			
GF	1812	1.50 ± 0.10	1000	4000			
GG	1812	1.55 ± 0.10	1000	4000			
GK	1812	1.60 ± 0.20	1000	4000			
GJ	1812	1.70 ± 0.15	1000	4000			
GN	1812	1.70 ± 0.20	1000	4000			
GL	1812	1.90 ± 0.20	1000	4000			
GM	1812	2.00 ± 0.20	1000	4000			
GO	1812	2.50 ± 0.20	500	2000			
GP	1812	2.65 ± 0.35	500	1400			
GR	1812	5.00 ± 0.50	350	1000			
HB	1825	1.10 ± 0.15	1000	4000			
HC	1825	1.15 ± 0.15	1000	4000			
HD	1825	1.30 ± 0.15	1000	4000			
HE	1825	1.40 ± 0.15	1000	4000			
HF	1825	1.50 ± 0.15	1000	4000			
Thickness Code	Chip Size	Thickness ± Range (mm)	QTY per Reel 7" Plastic	QTY per Reel 13" Plastic	QTY per Reel 7" Paper	QTY per Reel 13" Paper	QTY per Bulk Cassette

Package Quantity
 Based on Finished Chip
 Thickness Specifications

Table 2 – Chip Thickness/Packaging Quantities con't

Thickness Code	Chip Size	Thickness ± Range (mm)	QTY per Reel 7" Plastic	QTY per Reel 13" Plastic	QTY per Reel 7" Paper	QTY per Reel 13" Paper	QTY per Bulk Cassette
HG	1825	1.60 ± 0.20	1000	4000			
JB	2220	1.00 ± 0.15	1000	4000			
JC	2220	1.10 ± 0.15	1000	4000			
JD	2220	1.30 ± 0.15	1000	4000			
JE	2220	1.40 ± 0.15	1000	4000			
JF	2220	1.50 ± 0.15	1000	4000			
JP	2220	1.60 ± 0.20	1000	4000			
JG	2220	1.70 ± 0.15	1000	4000			
JH	2220	1.80 ± 0.15	1000	4000			
JO	2220	2.40 ± 0.15	500	2000			
JP	2220	3.50 ± 0.30	250	850			
JR	2220	5.00 ± 0.50	150	600			
KB	2225	1.00 ± 0.15	1000	4000			
KC	2225	1.10 ± 0.15	1000	4000			
KD	2225	1.30 ± 0.15	1000	4000			
KE	2225	1.40 ± 0.15	1000	4000			
KF	2225	1.60 ± 0.20	1000	4000			
Thickness Code	Chip Size	Thickness ± Range (mm)	QTY per Reel 7" Plastic	QTY per Reel 13" Plastic	QTY per Reel 7" Paper	QTY per Reel 13" Paper	QTY per Bulk Cassette

Table 3A – Land Pattern Design Recommendations per IPC-7351 (Standard Termination)

EIA Size Code	Metric Size Code	Density Level A: Maximum (Most) Land Protrusion (mm)					Density Level B: Median (Nominal) Land Protrusion (mm)					Density Level C: Minimum (Least) Land Protrusion (mm)				
		C	Y	X	V1	V2	C	Y	X	V1	V2	C	Y	X	V1	V2
01005	0402	0.33	0.46	0.43	1.60	0.90	0.28	0.36	0.33	1.30	0.70	0.23	0.26	0.23	1.00	0.50
0201	0603	0.38	0.56	0.52	1.80	1.00	0.33	0.46	0.42	1.50	0.80	0.28	0.36	0.32	1.20	0.60
0402	1005	0.50	0.72	0.72	2.20	1.20	0.45	0.62	0.62	1.90	1.00	0.40	0.52	0.52	1.60	0.80
0603	1608	0.90	1.15	1.10	4.00	2.10	0.80	0.95	1.00	3.10	1.50	0.60	0.75	0.90	2.40	1.20
0805	2012	1.00	1.35	1.55	4.40	2.60	0.90	1.15	1.45	3.50	2.00	0.75	0.95	1.35	2.80	1.70
1206	3216	1.60	1.35	1.90	5.60	2.90	1.50	1.15	1.80	4.70	2.30	1.40	0.95	1.70	4.00	2.00
1210	3225	1.60	1.35	2.80	5.65	3.80	1.50	1.15	2.70	4.70	3.20	1.40	0.95	2.60	4.00	2.90
1808	4520	2.30	1.75	2.30	7.40	3.30	2.20	1.55	2.20	6.50	2.70	2.10	1.35	2.10	5.80	2.40
1812	4532	2.15	1.60	3.60	6.90	4.60	2.05	1.40	3.50	6.00	4.00	1.95	1.20	3.40	5.30	3.70
1825	4564	2.15	1.60	6.90	6.90	7.90	2.05	1.40	6.80	6.00	7.30	1.95	1.20	6.70	5.30	7.00
2220	5650	2.75	1.70	5.50	8.20	6.50	2.65	1.50	5.40	7.30	5.90	2.55	1.30	5.30	6.60	5.60
2225	5664	2.70	1.70	6.90	8.10	7.90	2.60	1.50	6.80	7.20	7.30	2.50	1.30	6.70	6.50	7.00

Density Level A: For low-density Product applications. Recommended for wave solder applications and provides a wider process window for reflow solder processes. KEMET only recommends wave soldering of EIA 0603, 0805 and 1206 case sizes.

Density Level B: For products with a moderate level of component density. Provides a robust solder attachment condition for reflow solder processes.

Density Level C: For high component density product applications. Before adapting the minimum land pattern variations the user should perform qualification testing based on the conditions outlined in IPC standard 7351 (IPC-7351).

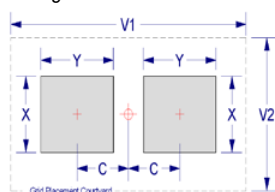

Table 3B – Land Pattern Design Recommendations per IPC-7351 (Flexible Termination)

EIA Size Code	Metric Size Code	Density Level A: Maximum (Most) Land Protrusion (mm)					Density Level B: Median (Nominal) Land Protrusion (mm)					Density Level C: Minimum (Least) Land Protrusion (mm)				
		C	Y	X	V1	V2	C	Y	X	V1	V2	C	Y	X	V1	V2
0603	1608	0.85	1.25	1.10	4.00	2.10	0.75	1.05	1.00	3.10	1.50	0.65	0.85	0.90	2.40	1.20
0805	2012	1.10	1.30	1.55	4.50	2.60	1.00	1.10	1.45	3.60	2.00	0.90	0.90	1.35	2.90	1.70
1206	3216	1.60	1.65	1.90	5.90	2.90	1.50	1.45	1.80	5.00	2.30	1.40	1.25	1.70	4.30	2.00
1210	3225	1.60	1.65	2.80	5.90	3.80	1.50	1.45	2.70	5.00	3.20	1.40	1.25	2.60	4.30	2.90
1808	4520	2.25	1.85	2.30	7.40	3.30	2.15	1.65	2.20	6.50	2.70	2.05	1.45	2.10	5.80	2.40
1812	4532	2.10	1.80	3.60	7.00	4.60	2.00	1.60	3.50	6.10	4.00	1.90	1.40	3.40	5.40	3.70
1825	4564	2.15	1.80	6.90	7.10	7.90	2.05	1.60	6.80	6.20	7.30	1.95	1.40	6.70	5.50	7.00
2220	5650	2.85	2.10	5.50	8.80	6.50	2.75	1.90	5.40	7.90	5.90	2.65	1.70	5.30	7.20	5.60
2225	5664	2.85	2.10	6.90	8.80	7.90	2.75	1.90	6.80	7.90	7.30	2.65	1.70	6.70	7.20	7.00

Density Level A: For low-density Product applications. Recommended for wave solder applications and provides a wider process window for reflow solder processes. KEMET only recommends wave soldering of EIA 0603, 0805 and 1206 case sizes.

Density Level B: For products with a moderate level of component density. Provides a robust solder attachment condition for reflow solder processes.

Density Level C: For high component density product applications. Before adapting the minimum land pattern variations the user should perform qualification testing based on the conditions outlined in IPC standard 7351 (IPC-7351).

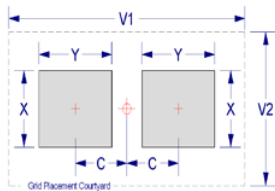

Soldering Process

Recommended Soldering Technique:

- Solder wave or solder reflow for EIA case sizes 0603, 0805 and 1206
- All other EIA case sizes are limited to solder reflow only

Recommended Soldering Profile:

- KEMET recommends following the guidelines outlined in IPC/JEDEC J-STD-020

Table 4 – Performance & Reliability: Test Methods and Conditions

Stress	Reference	Test or Inspection Method
Terminal Strength	JIS-C-6429	Appendix 1, Note: Force of 1.8kg for 60 seconds.
Board Flex	JIS-C-6429	Appendix 2, Note: 2mm (min) for all except 3mm for C0G.
Solderability	J-STD-002	Magnification 50 X. Conditions:
		a) Method B, 4 hours @ 155°C, dry heat @ 235°C
		b) Method B @ 215°C category 3
		c) Method D, category 3 @ 260°C
Temperature Cycling	JESD22 Method JA-104	1000 cycles (-55°C to +125°C). Measurement at 24 hours. +/- 2 hours after test conclusion.
Biased Humidity	MIL-STD-202 Method 103	Load Humidity: 1000 hours 85°C/85%RH and Rated Voltage. Add 100K ohm resistor. Measurement at 24 hours. +/- 2 hours after test conclusion.
		Low Volt Humidity: 1000 hours 85°C/85%RH and 1.5V. Add 100K ohm resistor. Measurement at 24 hours. +/- 2 hours after test conclusion.
Moisture Resistance	MIL-STD-202 Method 106	t = 24 hours/cycle. Steps 7a & 7b not required. Unpowered. Measurement at 24 hours. +/- 2 hours after test conclusion.
Thermal Shock	MIL-STD-202 Method 107	-55°C/+125°C. Note: Number of cycles required-300, maximum transfer time-20 seconds, dwell time-15 minutes. Air-Air.
High Temperature Life	MIL-STD-202 Method 108 / EIA -198	1000 hours at 125°C (85°C for X5R, Z5U and Y5V) with 2x rated voltage applied.
Storage Life	MIL-STD-202 Method 108	150°C, 0VDC, for 1000 hours.
Mechanical Shock	MIL-STD-202 Method 213	Figure 1 of Method 213, Condition F.
Resistance to Solvents	MIL-STD-202 Method 215	Add aqueous wash chemical - OKEM Clean or equivalent.

Storage and Handling

Ceramic chip capacitors should be stored in normal working environments. While the chips themselves are quite robust in other environments, solderability will be degraded by exposure to high temperatures, high humidity, corrosive atmospheres, and long term storage. In addition, packaging materials will be degraded by high temperature – reels may soften or warp, and tape peel force may increase. KEMET recommends that maximum storage temperature not exceed 40°C, and maximum storage humidity not exceed 70% relative humidity. In addition, temperature fluctuations should be minimized to avoid condensation on the parts, and atmospheres should be free of chlorine and sulfur bearing compounds. For optimized solderability, chip stock should be used promptly, preferably within 1.5 years of receipt.

High Temperature 200°C, C0G Dielectric, 10VDC-200VDC (Industrial Grade)

Overview

KEMET's high temperature surface mount C0G Multilayer Ceramic Capacitors (MLCCs) feature a robust, proprietary base metal dielectric system that offers industry-leading performance relative to capacitance and case size combined with capacitance stability at extreme temperatures up to +200°C. This new platform promotes downsizing opportunities of existing high temperature C0G technology, and offers replacement opportunities of existing X7R, BX and BR dielectric technologies.

KEMET's high temperature C0G dielectric features a 200°C maximum operating temperature and is considered "stable." The Electronics Components, Assemblies & Materials Association (EIA) characterizes C0G dielectric as a Class I material. Components of this classification are temperature compensating and are suited for resonant circuit applications or those where Q and stability of capacitance characteristics are required. C0G exhibits no change in capacitance with respect to time and voltage and boasts a negligible change in capacitance with reference to ambient temperature. Capacitance change is limited to $\pm 30\text{ppm}/^\circ\text{C}$ from -55°C to $+200^\circ\text{C}$.

Benefits

- -55°C to $+200^\circ\text{C}$ operating temperature range
- RoHS compliant
- EIA 0402, 0603, 0805, 1206, 1210, 1812 & 2220 case sizes
- DC voltage ratings of 10V, 16V, 25V, 50V, 100V and 200V
- Capacitance offerings ranging from 0.5pF up to 0.47 μF
- Available capacitance tolerances of $\pm 0.25\text{pF}$, $\pm 0.5\text{pF}$, $\pm 1\%$, $\pm 2\%$, $\pm 5\%$, $\pm 10\%$ or $\pm 20\%$
- No piezoelectric noise
- Extremely low ESR and ESL
- High thermal stability
- High ripple current capability
- Preferred capacitance solution at line frequencies and into the MHz range

- No capacitance change with respect to applied rated DC voltage
- Negligible capacitance change with respect to temperature from -55°C to $+200^\circ\text{C}$
- No capacitance decay with time
- Non-polar device, minimizing installation concerns
- 100% pure matte tin-plated termination finish allowing for excellent solderability

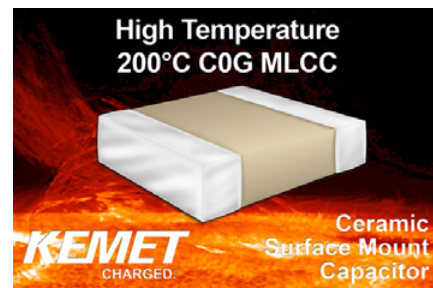

Ordering Information

C	1210	H	124	J	5	G	A	C	TU
Ceramic	Case Size (L" x W")	Specification/ Series	Capacitance Code (pF)	Capacitance Tolerance ¹	Voltage	Dielectric	Failure Rate/ Design	Termination Finish ²	Packaging/Grade (C-Spec) ³
	0402 0603 0805 1206 1210 1812 2220	H= High Temp (200°C)	2 Sig. Digits + Number of Zeros Use 9 for 1.0 - 9.9pF Use 8 for 0.5 - .99pF ex. 2.2pF = 229 ex. 0.5pF = 508	C = $\pm 0.25\text{pF}$ D = $\pm 0.5\text{pF}$ F = $\pm 1\%$ G = $\pm 2\%$ J = $\pm 5\%$ K = $\pm 10\%$ M = $\pm 20\%$	8 = 10V 4 = 16V 3 = 25V 5 = 50V 1 = 100V 2 = 200V	G = C0G	A = N/A	C = 100% Matte Sn L = SnPb (5% min)	Blank = Bulk TU = 7" Reel Unmarked

¹ Additional capacitance tolerance offerings may be available. Contact KEMET for details.

² Additional termination finish options may be available. Contact KEMET for details.

³ Additional reeling or packaging options may be available. Contact KEMET for details.

Dimensions – Millimeters (Inches)

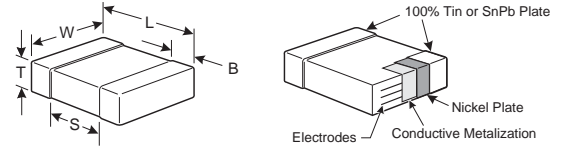

EIA Size Code	Metric Size Code	L Length	W Width	T Thickness	B Bandwidth	S Separation Min.	Mounting Technique
0402	1005	1.00 (.040) ± 0.05 (.002)	0.50 (.020) ± 0.05 (.002)	See Table 2 for Thickness	0.30 (.012) ± 0.10 (.004)	0.30 (.012)	Solder Reflow Only
0603	1608	1.60 (.063) ± 0.15 (.006)	0.80 (.032) ± 0.15 (.006)		0.35 (.014) ± 0.15 (.006)	0.70 (.028)	Solder Wave or Solder Reflow
0805	2012	2.00 (.079) ± 0.20 (.008)	1.25 (.049) ± 0.20 (.008)		0.50 (0.02) ± 0.25 (.010)	0.75 (.030)	
1206	3216	3.20 (.126) ± 0.20 (.008)	1.60 (.063) ± 0.20 (.008)		0.50 (0.02) ± 0.25 (.010)	N/A	Solder Reflow Only
1210	3225	3.20 (.126) ± 0.20 (.008)	2.50 (.098) ± 0.20 (.008)		0.50 (0.02) ± 0.25 (.010)		
1812	4532	4.50 (.177) ± 0.30 (.012)	3.20 (.126) ± 0.30 (.012)		0.60 (.024) ± 0.35 (.014)		
2220	5650	5.70 (.224) ± 0.40 (.016)	5.00 (.197) ± 0.40 (.016)		0.60 (.024) ± 0.35 (.014)		

Applications

Typical applications include critical timing, tuning, circuits requiring low loss, circuits with pulse, high current, decoupling, bypass, filtering, transient voltage suppression, blocking and energy storage for use in extreme environments such as down-hole exploration, aerospace engine compartments and geophysical probes.

Qualification/Certification

Commercial grade products are subject to internal qualification. Details regarding test methods and conditions are referenced in Table 4, Performance and Reliability.

Environmental Compliance

RoHS compliant (excluding SnPb termination finish option)

Electrical Parameters/Characteristics

Item	Parameters/Characteristics
Operating Temperature Range	-55°C to +200°C
Capacitance Change with Reference to +25°C and 0 Vdc Applied (TCC)	±30PPM/°C (up to +200°C)
Aging Rate (Max % Cap Loss/Decade Hour)	0%
Dielectric Withstanding Voltage	250% of rated voltage (5 ± 1 seconds and charge/discharge not exceeding 50mA)
Dissipation Factor (DF) Maximum Limits @ 25°C	0.1%
Insulation Resistance (IR) Limit @ 25°C	1000 megohm microfarads or 100GΩ
Insulation Resistance (IR) Limit @ 200°C	1000 megohm microfarads or 100GΩ (Rated voltage applied for 120 ± 5 secs @ 25°C)

To obtain IR limit, divide $M\Omega\text{-}\mu F$ value by the capacitance and compare to $G\Omega$ limit. Select the lower of the two limits.

Capacitance and Dissipation Factor (DF) measured under the following conditions:

1MHz ± 100kHz and 1.0Vrms ± 0.2V if capacitance ≤ 1000pF

1kHz ± 50Hz and 1.0Vrms ± 0.2V if capacitance > 1000pF

Note: When measuring capacitance it is important to ensure the set voltage level is held constant. The HP4284 & Agilent E4980 have a feature known as Automatic Level Control (ALC). The ALC feature should be switched to "ON".

Post Environmental Limits

High Temperature Life, Biased Humidity, Moisture Resistance					
Dielectric	Rated DC Voltage	Capacitance Value	DF (%)	Cap Shift	IR
C0G	All	All	0.5	0.3% or ± 0.25 pF	10% of Initial Limit

Electrical Characteristics

Delta Cap vs. Temperature (Typical)

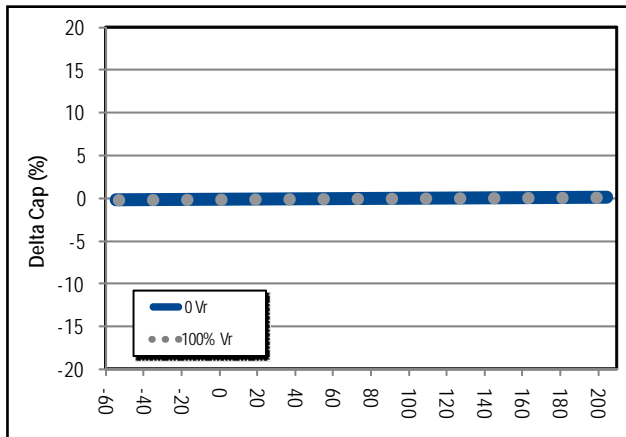

C1210H104J1GAC - Life Test IR Distribution (Lognormal)

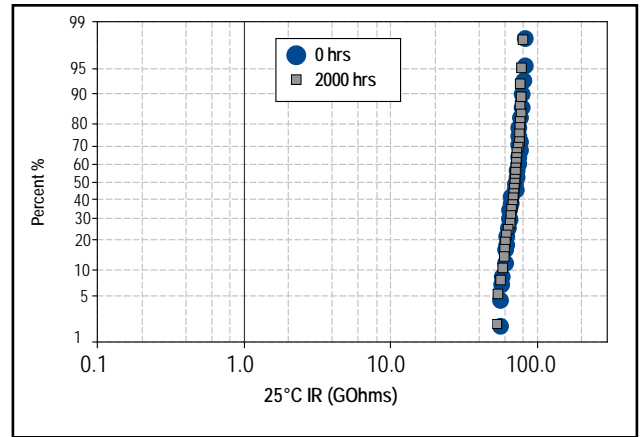

Capacitance vs. Temperature with 25V DC Bias (Rated Voltage)

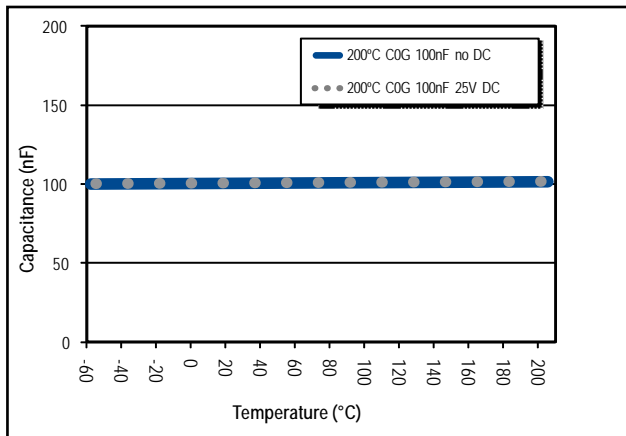

DF vs. Temperature without DC Bias.

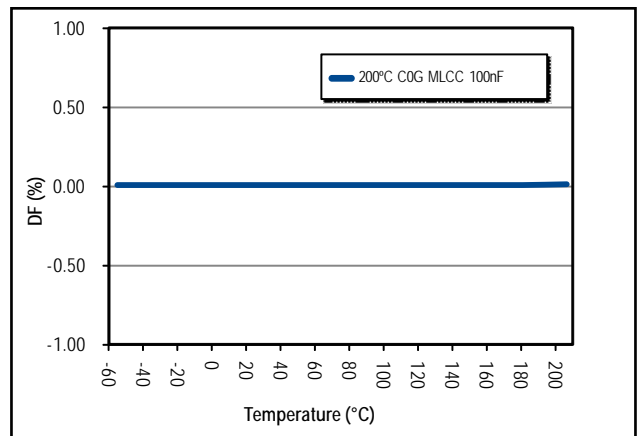

IR vs. Temperature with 25V DC Bias (Rated Voltage)

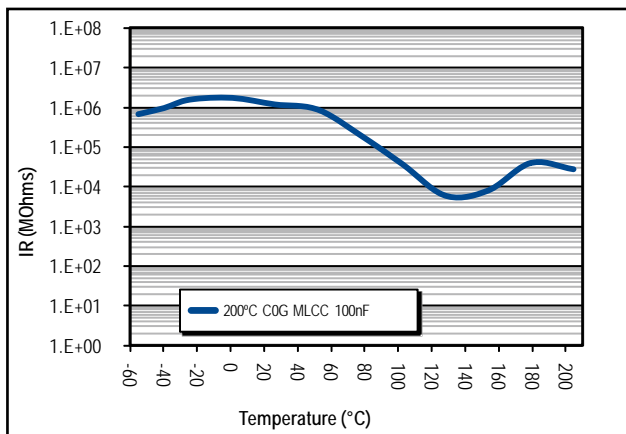

BME vs. PME/IR vs. Temperature with 25V DC Bias (Rated Voltage)

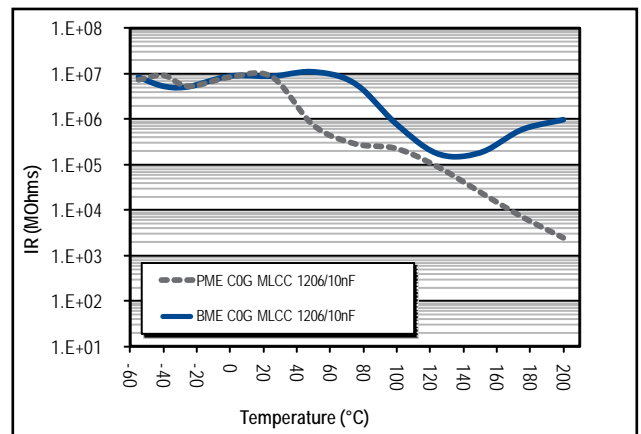

Table 1B – High Temperature 200°C, C0G Dielectric, (1210 - 2220 Case Sizes) con't

Cap	Cap Code	Series						C1210						C1812		C2220	
		Voltage Code						8	4	3	5	1	2	5	1	5	1
		Voltage DC						10	16	25	50	100	200	50	100	50	100
		Cap Tolerance						Product Availability and Chip Thickness Codes - See Table 2 for Chip Thickness Dimensions									
1,000 pF	102	F	G	J	K	M	FB	FB	FB	FB	FB	FB					
1,100 pF	112	F	G	J	K	M	FB	FB	FB	FB	FB	FB					
1,200 pF	122	F	G	J	K	M	FB	FB	FB	FB	FB	FB					
1,300 pF	132	F	G	J	K	M	FB	FB	FB	FB	FB	FC					
1,500 pF	152	F	G	J	K	M	FB	FB	FB	FB	FB	FE					
1,600 pF	162	F	G	J	K	M	FB	FB	FB	FB	FB	FE					
1,800 pF	182	F	G	J	K	M	FB	FB	FB	FB	FB	FE					
2,000 pF	202	F	G	J	K	M	FB	FB	FB	FB	FC	FE					
2,200 pF	222	F	G	J	K	M	FB	FB	FB	FB	FC	FG					
2,400 pF	242	F	G	J	K	M	FB	FB	FB	FB	FC	FC					
2,700 pF	272	F	G	J	K	M	FB	FB	FB	FB	FC	FC					
3,000 pF	302	F	G	J	K	M	FB	FB	FB	FB	FC	FF					
3,300 pF	332	F	G	J	K	M	FB	FB	FB	FB	FF	FF					
3,600 pF	362	F	G	J	K	M	FB	FB	FB	FB	FF	FF					
3,900 pF	392	F	G	J	K	M	FB	FB	FB	FB	FF	FF					
4,300 pF	432	F	G	J	K	M	FB	FB	FB	FB	FF	FF					
4,700 pF	472	F	G	J	K	M	FF	FF	FF	FF	FG	FG					
5,100 pF	512	F	G	J	K	M	FB	FB	FB	FB	FG	FG					
5,600 pF	562	F	G	J	K	M	FB	FB	FB	FB	FG	FG					
6,200 pF	622	F	G	J	K	M	FB	FB	FB	FB	FG						
6,800 pF	682	F	G	J	K	M	FB	FB	FB	FB	FG						
7,500 pF	752	F	G	J	K	M	FC	FC	FC	FC	FC						
8,200 pF	822	F	G	J	K	M	FC	FC	FC	FC	FC						
9,100 pF	912	F	G	J	K	M	FE	FE	FE	FE	FE						
10,000 pF	103	F	G	J	K	M	FF	FF	FF	FF	FF						
12,000 pF	123	F	G	J	K	M	FG	FG	FG	FG	FB						
15,000 pF	153						FG	FG	FG	FG	FB	GB	GB				
18,000 pF	183						FB	FB	FB	FB	FB	GB	GB				
22,000 pF	223						FB	FB	FB	FB	FB	GB	GB				
27,000 pF	273						FB	FB	FB	FB	FB	GB	GB				
33,000 pF	333						FB	FB	FB	FB	FB	GB	GB				
47,000 pF	473						FB	FB	FB	FB	FE	GB	GB				
56,000 pF	563						FB	FB	FB	FB	FF	GB	GB				
68,000 pF	683						FB	FB	FB	FC	FG	GB	GB				
82,000 pF	823						FC	FC	FC	FF	FH	GB	GB				
0.10 µF	104						FE	FE	FE	FG	FM	GB	GD				
0.12 µF	124						FG	FG	FG	FH		GB	GH				
0.15 µF	154						FH	FH	FH	FM		GD	GN				
0.18 µF	184						UD	UD	UD			GH					
0.22 µF	224						UD	UD	UD			GK					
0.27 µF	274																
0.33 µF	334																
0.47 µF	474														JG		
0.56 µF	564																
0.68 µF	684																
0.82 µF	824																
Cap	Cap Code	Voltage DC						10	16	25	50	100	200	50	100	50	100
		Voltage Code						8	4	3	5	1	2	5	1	5	1
		Series						C1210						C1812		C2220	

UD = Under Development

KEMET reserves the right to substitute product with an improved temperature characteristic, tighter capacitance tolerance and/or higher voltage capability within the same form factor (configuration and dimensions).

These products are protected under US Patents 7,172,985 & 7,670,981, other patents pending, and any foreign counterparts.

Table 2 – Chip Thickness/Packaging Quantities

Thickness Code	Chip Size	Thickness ± Range (mm)	QTY per Reel 7" Plastic	QTY per Reel 13" Plastic	QTY per Reel 7" Paper	QTY per Reel 13" Paper	QTY per Bulk Cassette
AA	1005	0.20 ± 0.02			15000		
AB	0201	0.30 ± 0.03			15000		
BB	0402	0.50 ± 0.05			10000	50000	50000
BC	0402	0.50 ± 0.10			10000	50000	50000
PA	0508	0.80 ± 0.10	4000	10000			
CB	0603	0.80 ± 0.07			4000	10000	15000
CC	0603	0.80 ± 0.10			4000	10000	15000
CD	0603	0.80 ± 0.15			4000	10000	15000
MA	0612	0.80 ± 0.10	4000	10000			
DB	0805	0.60 ± 0.10			4000	10000	15000
DC	0805	0.78 ± 0.10			4000	10000	15000
DD	0805	0.90 ± 0.10			4000	10000	15000
DL	0805	0.95 ± 0.10	4000	10000			
DE	0805	1.00 ± 0.10	2500	10000			
DF	0805	1.10 ± 0.10	2500	10000			
DG	0805	1.25 ± 0.15	2500	10000			
DH	0805	1.25 ± 0.20	2500	10000			
EB	1206	0.78 ± 0.10	4000	10000	4000	10000	
EK	1206	0.80 ± 0.10	2000	8000			
EC	1206	0.90 ± 0.10	4000	10000			
EN	1206	0.95 ± 0.10	4000	10000			
ED	1206	1.00 ± 0.10	2500	10000			
EE	1206	1.10 ± 0.10	2500	10000			
EF	1206	1.20 ± 0.15	2500	10000			
EM	1206	1.25 ± 0.15	2500	10000			
EG	1206	1.60 ± 0.15	2000	8000			
EH	1206	1.60 ± 0.20	2000	8000			
EJ	1206	1.70 ± 0.20	2000	8000			
FB	1210	0.78 ± 0.10	4000	10000			
FC	1210	0.90 ± 0.10	4000	10000			
FD	1210	0.95 ± 0.10	4000	10000			
FE	1210	1.00 ± 0.10	2500	10000			
FF	1210	1.10 ± 0.10	2500	10000			
FG	1210	1.25 ± 0.15	2500	10000			
FL	1210	1.40 ± 0.15	2000	8000			
FO	1210	1.50 ± 0.20	2000	8000			
FH	1210	1.55 ± 0.15	2000	8000			
FP	1210	1.60 ± 0.20	2000	8000			
FM	1210	1.70 ± 0.20	2000	8000			
FJ	1210	1.85 ± 0.20	2000	8000			
FN	1210	1.85 ± 0.20	2000	8000			
FT	1210	1.90 ± 0.20	1500	4000			
FK	1210	2.10 ± 0.20	2000	8000			
FR	1210	2.25 ± 0.20	2000	8000			
FS	1210	2.50 ± 0.20	1000	4000			
FV	1210	3.35 ± 0.10	500	1800			
FW	1210	6.15 ± 0.15	200	1000			
PA	1220	0.80 ± 0.10	4000	10000			
MA	1632	0.80 ± 0.10	4000	10000			
NA	1706	0.90 ± 0.10	4000	10000			
NB	1706	1.00 ± 0.10	4000	10000			
NC	1706	1.00 ± 0.15	4000	10000			
LD	1808	0.90 ± 0.10	2500	10000			
LE	1808	1.00 ± 0.10	2500	10000			
LF	1808	1.00 ± 0.15	2500	10000			
LA	1808	1.40 ± 0.15	1000	4000			
LB	1808	1.60 ± 0.15	1000	4000			
LC	1808	2.00 ± 0.15	1000	4000			
GB	1812	1.00 ± 0.10	1000	4000			
GC	1812	1.10 ± 0.10	1000	4000			
GD	1812	1.25 ± 0.15	1000	4000			
GE	1812	1.30 ± 0.10	1000	4000			
GH	1812	1.40 ± 0.15	1000	4000			
GF	1812	1.50 ± 0.10	1000	4000			
GG	1812	1.55 ± 0.10	1000	4000			
GK	1812	1.60 ± 0.20	1000	4000			
GJ	1812	1.70 ± 0.15	1000	4000			
GN	1812	1.70 ± 0.20	1000	4000			
GL	1812	1.90 ± 0.20	1000	4000			
GM	1812	2.00 ± 0.20	1000	4000			
GO	1812	2.50 ± 0.20	500	2000			
GP	1812	2.65 ± 0.35	500	1400			
GR	1812	5.00 ± 0.50	350	1000			
HB	1825	1.10 ± 0.15	1000	4000			
HC	1825	1.15 ± 0.15	1000	4000			
HD	1825	1.30 ± 0.15	1000	4000			
HE	1825	1.40 ± 0.15	1000	4000			
HF	1825	1.50 ± 0.15	1000	4000			
Thickness Code	Chip Size	Thickness ± Range (mm)	QTY per Reel 7" Plastic	QTY per Reel 13" Plastic	QTY per Reel 7" Paper	QTY per Reel 13" Paper	QTY per Bulk Cassette

Package Quantity
 Based on Finished Chip
 Thickness Specifications

Table 2 – Chip Thickness/Packaging Quantities cont'

Thickness Code	Chip Size	Thickness ± Range (mm)	QTY per Reel 7" Plastic	QTY per Reel 13" Plastic	QTY per Reel 7" Paper	QTY per Reel 13" Paper	QTY per Bulk Cassette
HG	1825	1.60 ± 0.20	1000	4000			
JB	2220	1.00 ± 0.15	1000	4000			
JC	2220	1.10 ± 0.15	1000	4000			
JD	2220	1.30 ± 0.15	1000	4000			
JE	2220	1.40 ± 0.15	1000	4000			
JF	2220	1.50 ± 0.15	1000	4000			
JP	2220	1.60 ± 0.20	1000	4000			
JG	2220	1.70 ± 0.15	1000	4000			
JH	2220	1.80 ± 0.15	1000	4000			
JO	2220	2.40 ± 0.15	500	2000			
JP	2220	3.50 ± 0.30	250	850			
JR	2220	5.00 ± 0.50	150	600			
KB	2225	1.00 ± 0.15	1000	4000			
KC	2225	1.10 ± 0.15	1000	4000			
KD	2225	1.30 ± 0.15	1000	4000			
KE	2225	1.40 ± 0.15	1000	4000			
KF	2225	1.60 ± 0.20	1000	4000			
Thickness Code	Chip Size	Thickness ± Range (mm)	QTY per Reel 7" Plastic	QTY per Reel 13" Plastic	QTY per Reel 7" Paper	QTY per Reel 13" Paper	QTY per Bulk Cassette

Table 3 – Chip Capacitor Land Pattern Design Recommendations per IPC-7351

EIA Size Code	Metric Size Code	Density Level A: Maximum (Most) Land Protrusion (mm)					Density Level B: Median (Nominal) Land Protrusion (mm)					Density Level C: Minimum (Least) Land Protrusion (mm)				
		C	Y	X	V1	V2	C	Y	X	V1	V2	C	Y	X	V1	V2
01005	0402	0.33	0.46	0.43	1.60	0.90	0.28	0.36	0.33	1.30	0.70	0.23	0.26	0.23	1.00	0.50
0201	0603	0.38	0.56	0.52	1.80	1.00	0.33	0.46	0.42	1.50	0.80	0.28	0.36	0.32	1.20	0.60
0402	1005	0.50	0.72	0.72	2.20	1.20	0.45	0.62	0.62	1.90	1.00	0.40	0.52	0.52	1.60	0.80
0603	1608	0.90	1.15	1.10	4.00	2.10	0.80	0.95	1.00	3.10	1.50	0.60	0.75	0.90	2.40	1.20
0805	2012	1.00	1.35	1.55	4.40	2.60	0.90	1.15	1.45	3.50	2.00	0.75	0.95	1.35	2.80	1.70
1206	3216	1.60	1.35	1.90	5.60	2.90	1.50	1.15	1.80	4.70	2.30	1.40	0.95	1.70	4.00	2.00
1210	3225	1.60	1.35	2.80	5.65	3.80	1.50	1.15	2.70	4.70	3.20	1.40	0.95	2.60	4.00	2.90
1808	4520	2.30	1.75	2.30	7.40	3.30	2.20	1.55	2.20	6.50	2.70	2.10	1.35	2.10	5.80	2.40
1812	4532	2.15	1.60	3.60	6.90	4.60	2.05	1.40	3.50	6.00	4.00	1.95	1.20	3.40	5.30	3.70
1825	4564	2.15	1.60	6.90	6.90	7.90	2.05	1.40	6.80	6.00	7.30	1.95	1.20	6.70	5.30	7.00
2220	5650	2.75	1.70	5.50	8.20	6.50	2.65	1.50	5.40	7.30	5.90	2.55	1.30	5.30	6.60	5.60
2225	5664	2.70	1.70	6.90	8.10	7.90	2.60	1.50	6.80	7.20	7.30	2.50	1.30	6.70	6.50	7.00

Density Level A: For low-density Product applications. Recommended for wave solder applications and provides a wider process window for reflow solder processes. KEMET only recommends wave soldering of EIA 0603, 0805 and 1206 case sizes.

Density Level B: For products with a moderate level of component density. Provides a robust solder attachment condition for reflow solder processes.

Density Level C: For high component density product applications. Before adapting the minimum land pattern variations the user should perform qualification testing based on the conditions outlined in IPC standard 7351 (IPC-7351).

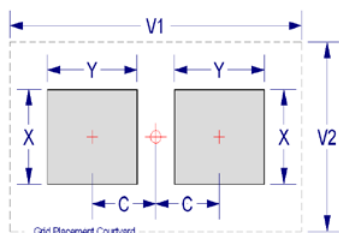

Soldering Process

Recommended Soldering Technique:

- Solder wave or solder reflow for EIA case sizes 0603, 0805 and 1206
- All other EIA case sizes are limited to solder reflow only

Recommended Soldering Profile:

- KEMET recommends following the guidelines outlined in IPC/JEDEC J-STD-020

Table 4 – Performance & Reliability: Test Methods and Conditions

Product Qualification Test Plan	
Reliability/Environmental Tests per MIL-STD-202//JESD22	
High Temperature Life	200°C, Rated Voltage, 2000 Hours
Load Humidity	85°C /85%RH, Rated Voltage, 1000 Hours
Low Voltage Humidity	85°C /85%RH, 1.5V, 1000 Hours
Temperature Cycling	-55°C to +200°C, 50 Cycles
Thermal Shock	-55°C to +150°C, 20s transfer, 15 min dwell, 300 Cycles
Moisture Resistance	Cycled Temp/RH. 0V, 10 cycles @ 24 Hours each
Physical, Mechanical & Process Tests per MIL-STD 202/JIS-C-6429	
Resistance to Solvents	Include Aqueous wash chemical - OKEM Clean or equivalent
Mechanical Shock and Vibration	Method 213: Figure 1, Condition F Method 204: 5gs for 20 min, 12 cycles
Resistance to Soldering Heat	Condition B, no per-heat of samples, Single Wave Solder
Terminal Strength	Force of 1.8 kg for 60 seconds
Board Flex	3mm minimum

Storage and Handling

Ceramic chip capacitors should be stored in normal working environments. While the chips themselves are quite robust in other environments, solderability will be degraded by exposure to high temperatures, high humidity, corrosive atmospheres, and long term storage. In addition, packaging materials will be degraded by high temperature – reels may soften or warp, and tape peel force may increase. KEMET recommends that maximum storage temperature not exceed 40°C, and maximum storage humidity not exceed 70% relative humidity. In addition, temperature fluctuations should be minimized to avoid condensation on the parts, and atmospheres should be free of chlorine and sulfur bearing compounds. For optimized solderability, chip stock should be used promptly, preferably within 1.5 years of receipt.

Surface Mount Multilayer Ceramic Chip Capacitors (SMD MLCCs)

High Voltage C0G Dielectric, 500VDC-3000VDC

(Commercial & Automotive Grade)

Overview

KEMET's high voltage surface mount MLCCs in C0G dielectric feature a 125°C maximum operating temperature and are considered "stable." The Electronics Components, Assemblies & Materials Association (EIA) characterizes C0G dielectric as a Class I material. Components of this classification are temperature compensating and are suited for resonant circuit applications or those where Q and stability of capacitance characteristics are required. C0G exhibits no change in capacitance with respect to time and voltage and boasts a negligible change in capacitance with reference to ambient temperature. Capacitance change is limited to $\pm 30\text{ppm}/^\circ\text{C}$ from -55°C to +125°C.

These devices exhibit low ESR at high frequencies and find conventional use as snubbers or filters in applications such as

switching power supplies and lighting ballasts. Their exceptional performance at high frequencies has made them a preferred choice of design engineers worldwide. In addition to their use in power supplies, these capacitors are widely used in industries related to automotive(hybrid), telecommunications, medical, military, aerospace, semiconductors and test/diagnostic equipment.

KEMET's high voltage surface mount MLCCs are manufactured in state of the art ISO/TS 16949:2002 certified facilities and are available in both commercial and automotive grades. Automotive grade devices meet the demanding Automotive Electronics Council's AEC-Q200 qualification requirements.

Benefits

- -55°C to +125°C operating temperature range
- RoHS compliant
- No piezoelectric noise
- Extremely low ESR and ESL
- High thermal stability
- High ripple current capability
- Preferred capacitance solution at line frequencies and into the MHz range
- No capacitance change with respect to applied rated DC voltage
- Negligible capacitance change with respect to temperature from -55°C to +125°C
- No capacitance decay with time
- Non-polar device, minimizing installation concerns
- Commercial & Automotive (AEC-Q200) grades available
- 100% pure matte tin-plated termination finish allowing for excellent solderability
- SnPb plated termination finish option available upon request (5% min)

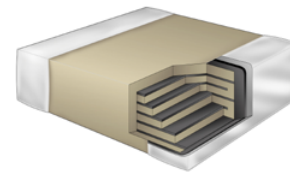

Ordering Information

C	1210	C	332	J	C	G	A	C	TU
Ceramic	Case Size (L" x W")	Specification/ Series	Capacitance Code (pF)	Capacitance Tolerance ¹	Voltage	Dielectric	Failure Rate/ Design	Termination Finish ²	Packaging/Grade (C-Spec) ³
	0805 1206 1210 1808 1812 1825 2220 2225	C = Standard	2 Sig. Digits + Number of Zeros Use 9 for 1.0 - 9.9pF Use 8 for 0.5 - .99pF ex. 2.2pF = 229 ex. 0.5pF = 508	C = $\pm 0.25\text{pF}$ D = $\pm 0.5\text{pF}$ F = $\pm 1\%$ G = $\pm 2\%$ J = $\pm 5\%$ K = $\pm 10\%$ M = $\pm 20\%$	C = 500V B = 630V D = 1000V F = 1500V G = 2000V Z = 2500V H = 3000V	G = C0G	A = N/A	C = 100% Matte Sn L = SnPb (5% min)	Blank = Bulk TU = 7" Reel Unmarked AUTO = Automotive Grade 7" Reel Unmarked

¹ Additional capacitance tolerance offerings may be available. Contact KEMET for details.

² SnPb termination finish option is not available on automotive grade product.

² Additional termination finish options may be available. Contact KEMET for details.

³ Additional reeling or packaging options may be available. Contact KEMET for details.

Dimensions – Millimeters (Inches)

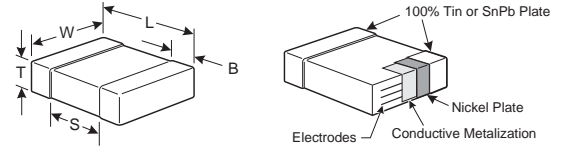

EIA Size Code	Metric Size Code	L Length	W Width	T Thickness	B Bandwidth	S Separation Min.	Mounting Technique
0805	2012	2.00 (.079) ± 0.20 (.008)	1.25 (.049) ± 0.20 (.008)	See Table 2 for Thickness	0.50 (0.02) ± 0.25 (.010)	0.75 (.030)	Solder Wave or Solder Reflow
1206	3216	3.20 (.126) ± 0.20 (.008)	1.60 (.063) ± 0.20 (.008)		0.50 (0.02) ± 0.25 (.010)	N/A	
1210	3225	3.20 (.126) ± 0.20 (.008)	2.50 (.098) ± 0.20 (.008)		0.50 (0.02) ± 0.25 (.010)		
1808	4520	4.70 (.185) ± 0.50 (.020)	2.00 (.079) ± 0.20 (.008)		0.60 (.024) ± 0.35 (.014)		
1812	4532	4.50 (.177) ± 0.30 (.012)	3.20 (.126) ± 0.30 (.012)		0.60 (.024) ± 0.35 (.014)		
1825	4564	4.50 (.177) ± 0.30 (.012)	6.40 (.252) ± 0.40 (.016)		0.60 (.024) ± 0.35 (.014)		
2220	5650	5.70 (.224) ± 0.40 (.016)	5.00 (.197) ± 0.40 (.016)		0.60 (.024) ± 0.35 (.014)		
2225	5664	5.60 (.220) ± 0.40 (.016)	6.40 (.248) ± 0.40 (.016)		0.60 (.024) ± 0.35 (.014)		Solder Reflow Only

Applications

Typical applications include switch mode power supplies (input filters, resonators, tank circuits, snubbed circuits, output filters), high voltage coupling and DC blocking, lighting ballasts, voltage multiplier circuits, DC/DC converters and coupling capacitors in Ćuk converters. Markets include power supply, LCD fluorescent backlight ballasts, HID lighting, telecom equipment, industrial and medical equipment/control, LAN/WAN interface, analog and digital modems, and automotive.

Qualification/Certification

Commercial grade products are subject to internal qualification. Details regarding test methods and conditions are referenced in Table 4, Performance and Reliability.

Automotive grade products meet or exceed the requirements outlined by the Automotive Electronics Council. Details regarding test methods and conditions are referenced in document AEC-Q200, Stress Test Qualification for Passive Components. For additional information regarding the Automotive Electronics Council and AEC-Q200, please visit their website @www.aecouncil.com.

Environmental Compliance

RoHS compliant (excluding SnPb termination finish option)

Electrical Parameters/Characteristics

Item	Parameters/Characteristics
Operating Temperature Range	-55°C to +125°C
Capacitance Change with Reference to +25°C and 0 Vdc Applied (TCC)	±30PPM/°C
Aging Rate (Max % Cap Loss/Decade Hour)	0%
Dielectric Withstanding Voltage	150% of rated voltage for voltage rating of < 1000V 120% of rated voltage for voltage rating of ≥ 1000V (5 ± 1 seconds and charge/discharge not exceeding 50mA)
Dissipation Factor (DF) Maximum Limit @ 25°C	0.1%
Insulation Resistance (IR) Limit @ 25°C	1000 megohm microfarads or 100GΩ (Rated voltage applied for 120 ± 5 secs @ 25°C)

To obtain IR limit, divide $M\Omega\text{-}\mu F$ value by the capacitance and compare to $G\Omega$ limit. Select the lower of the two limits.

Capacitance and Dissipation Factor (DF) measured under the following conditions:

1MHz ± 100kHz and 1.0Vrms ± 0.2V if capacitance ≤ 1000pF

1kHz ± 50Hz and 1.0Vrms ± 0.2V if capacitance > 1000pF

Note: When measuring capacitance it is important to ensure the set voltage level is held constant. The HP4284 & Agilent E4980 have a feature known as Automatic Level Control (ALC). The ALC feature should be switched to "ON".

Post Environmental Limits

High Temperature Life, Biased Humidity, Moisture Resistance					
Dielectric	Rated DC Voltage	Capacitance Value	DF (%)	Cap Shift	IR
C0G	All	All	0.5	0.3% or ± 0.25 pF	10% of Initial Limit

Table 1A – High Voltage COG Dielectric, (0805 - 1808 Case Sizes)

Cap	Cap Code	Series			C0805			C1206					C1210					C1808							
		Voltage Code			C	B	D	C	B	D	F	G	C	B	D	F	G	C	B	D	F	G	Z	H	
		Voltage DC			500	630	1000	500	630	1000	1500	2000	500	630	1000	1500	2000	500	630	1000	1500	2000	2500	3000	
		Cap Tolerance			Product Availability and Chip Thickness Codes - See Table 2 for Chip Thickness Dimensions																				
1.0-2.4 pF	109-249	C	D			DG	DG	DG											LB	LB	LB	LB	LB	LB	LB
2.7-5.1 pF	279-519	C	D			DG	DG	DG											LB	LB	LB	LB	LB	LB	LB
5.6-9.1 pF	569-919	C	D		J	K	M	DG	DG	DG									LB	LB	LB	LB	LB	LB	LB
10 pF	100	C	D		J	K	M	DG	DG	DG									LB	LB	LB	LB	LB	LB	LB
11 pF	110	C	D		J	K	M	DG	DG	DG	EG	EG	EG	EG	EG	FM	FM	FM	FM	FM	FM	FM	FM	FM	FM
12 pF	120	C	D		J	K	M	DG	DG	DG	EG	EG	EG	EG	EG	FM	FM	FM	FM	FM	FM	FM	FM	FM	FM
13 pF	130	C	D		J	K	M	DG	DG	DG	EG	EG	EG	EG	EG	FM	FM	FM	FM	FM	FM	FM	FM	FM	FM
15 pF	150	C	D		J	K	M	DG	DG	DG	EG	EG	EG	EG	EG	FM	FM	FM	FM	FM	FM	FM	FM	FM	FM
16 pF	160	C	D		J	K	M	DG	DG	DG	EG	EG	EG	EG	EG	FM	FM	FM	FM	FM	FM	FM	FM	FM	FM
18 pF	180	C	D		J	K	M	DG	DG	DG	EG	EG	EG	EG	EG	FM	FM	FM	FM	FM	FM	FM	FM	FM	FM
20 pF	200	C	D		J	K	M	DG	DG	DG	EG	EG	EG	EG	EG	FM	FM	FM	FM	FM	FM	FM	FM	FM	FM
22 pF	220	C	D		J	K	M	DG	DG	DG	EG	EG	EG	EG	EG	FM	FM	FM	FM	FM	FM	FM	FM	FM	FM
24 pF	240	C	D		J	K	M	DG	DG	DG	EG	EG	EG	EG	EG	FM	FM	FM	FM	FM	FM	FM	FM	FM	FM
27 pF	270	D	F	G	J	K	M	DG	DG	DG	EG	EG	EG	EG	EG	FM	FM	FM	FM	FM	FM	FM	FM	FM	FM
30 pF	300	D	F	G	J	K	M	DG	DG	DG	EG	EG	EG	EG	EG	FM	FM	FM	FM	FM	FM	FM	FM	FM	FM
33 pF	330	D	F	G	J	K	M	DG	DG	DG	EG	EG	EG	EG	EG	FM	FM	FM	FM	FM	FM	FM	FM	FM	FM
36 pF	360	D	F	G	J	K	M	DG	DG	DG	EG	EG	EG	EG	EG	FM	FM	FM	FM	FM	FM	FM	FM	FM	FM
39 pF	390	D	F	G	J	K	M	DG	DG	DG	EG	EG	EG	EG	EG	FM	FM	FM	FM	FM	FM	FM	FM	FM	FM
43 pF	430	D	F	G	J	K	M	DG	DG	DG	EG	EG	EG	EG	EG	FM	FM	FM	FM	FM	FM	FM	FM	FM	FM
47 pF	470	D	F	G	J	K	M	DG	DG	DG	EG	EG	EG	EG	EG	FM	FM	FM	FM	FM	FM	FM	FM	FM	FM
51 pF	510	D	F	G	J	K	M	DG	DG	DG	EF	EF	EG	EG	EG	FM	FM	FM	FM	FM	FM	FM	FM	FM	FM
56 pF	560		F	G	J	K	M	DG	DG	DG	EF	EF	EG	EG	EG	FM	FM	FM	FM	FM	FM	FM	FM	FM	FM
62 pF	620		F	G	J	K	M	DG	DG	DG	EF	EF	EG	EG	EG	FM	FM	FM	FM	FM	FM	FM	FM	FM	FM
68 pF	680		F	G	J	K	M	DG	DG	DG	EF	EF	EG	EG	EG	FM	FM	FM	FM	FM	FM	FM	FM	FM	FM
75 pF	750		F	G	J	K	M	DG	DG	DG	EF	EF	EG	EG	EG	FM	FM	FM	FM	FM	FM	FM	FM	FM	FM
82 pF	820		F	G	J	K	M	DG	DG	DG	EF	EF	EG	EG	EG	FM	FM	FM	FM	FM	FM	FM	FM	FM	FM
91 pF	910		F	G	J	K	M	DG	DG	DG	EF	EF	EG	EG	EG	FM	FM	FM	FM	FM	FM	FM	FM	FM	FM
100 pF	101		F	G	J	K	M	DG	DG	DG	EF	EF	EG	EG	EG	FM	FM	FM	FM	FM	FM	FM	FM	FM	FM
110 pF	111		F	G	J	K	M	DG	DG	DG	EF	EF	EG	EG	EG	FM	FM	FM	FM	FM	FM	FM	FM	FM	FM
120 pF	121		F	G	J	K	M	DG	DG	DG	EF	EF	EG	EG	EG	FG	FG	FG	FM	FM	LA	LA	LA	LA	LB
130 pF	131		F	G	J	K	M	DG			EF	EF	EF	EG	EG	FG	FG	FG	FM	FM	LA	LA	LA	LA	LB
150 pF	151		F	G	J	K	M	DG			EF	EF	EF	EG	EG	FG	FG	FG	FM	FM	LA	LA	LA	LA	LB
160 pF	161		F	G	J	K	M	DG			EF	EF	EF	EG	EG	FG	FG	FG	FM	FM	LA	LA	LA	LA	LC
180 pF	181		F	G	J	K	M	DG			EF	EF	EF	EG	EG	FG	FG	FG	FM	FM	LA	LA	LA	LA	LC
200 pF	201		F	G	J	K	M	DG			EF	EG	EG	EG	EG	FG	FG	FG	FM	FM	LA	LA	LA	LA	LC
220 pF	221		F	G	J	K	M	DG			EF	EG	EG	EG	EG	FG	FG	FG	FM	FM	LA	LA	LA	LA	LC
240 pF	241		F	G	J	K	M				EF	EG	EG	EG	EG	FG	FG	FG	FM	FM	LA	LA	LA	LA	LC
270 pF	271		F	G	J	K	M				EF	EG	EG	EG	EG	FG	FG	FG	FK	FK	LA	LA	LA	LA	LC
300 pF	301		F	G	J	K	M				EF	EG	EG	EG	EG	FG	FG	FG	FK	FK	LA	LA	LA	LA	LC
330 pF	331		F	G	J	K	M				EF	EG	EG	EG	EG	FG	FG	FG	FK	FK	LA	LA	LA	LA	LC
360 pF	361		F	G	J	K	M				EG	EG	EG	EG	EG	FG	FG	FG	FK	FS	LA	LA	LA	LA	LB
390 pF	391		F	G	J	K	M				EG	EG	EG	EG	EG	FG	FG	FG	FK	FS	LA	LA	LA	LA	LB
430 pF	431		F	G	J	K	M				EG	EG	EG	EG	EG	FG	FM	FM	FS	FS	LA	LB	LB	LB	LC
470 pF	471		F	G	J	K	M				EG	EG	EG	EG	EG	FG	FM	FM	FS	FS	LA	LB	LB	LB	LC
510 pF	511		F	G	J	K	M				EG	EG	EG	EG	EG	FG	FM	FM	FS	FS	LA	LB	LB	LB	LC
560 pF	561		F	G	J	K	M				EG	EG	EG	EG	EG	FG	FM	FM	FS	FS	LA	LB	LB	LB	LC
620 pF	621		F	G	J	K	M				EG	EG	EG	EG	EG	FG	FM	FM	FS	FS	LA	LB	LB	LB	LC
680 pF	681		F	G	J	K	M				EG	EG	EG	EG	EG	FG	FM	FM	FS	FS	LA	LB	LB	LB	LC
750 pF	751		F	G	J	K	M				EG	EG	EG	EG	EG	FG	FM	FM	FS	FS	LA	LB	LB	LB	LC
820 pF	821		F	G	J	K	M				EG	EG	EG	EG	EG	FG	FM	FM	FS	FS	LA	LB	LB	LB	LC
910 pF	911		F	G	J	K	M				EG	EG	EG	EG	EG	FM	FM	FM	FS	FS	LA	LB	LB	LB	LC
1,000 pF	102		F	G	J	K	M				EG	EG	EG	EG	EG	FM	FM	FM	FS	FS	LA	LB	LB	LB	LC
1,100 pF	112		F	G	J	K	M				EG	EG	EG	EG	EG	FM	FK	FK	FS	FS	LA	LB	LB	LB	LC
Cap	Cap Code	Voltage VDC			500	630	1000	500	630	1000	1500	2000	500	630	1000	1500	2000	500	630	1000	1500	2000	2500	3000	
		Voltage Code			C	B	D	C	B	D	F	G	C	B	D	F	G	C	B	D	F	G	Z	H	
		Series			C0805			C1206					C1210					C1808							

KEMET reserves the right to substitute product with an improved temperature characteristic, tighter capacitance tolerance and/or higher voltage capability within the same form factor (configuration and dimensions).

These products are protected under US Patents 7,172,985 & 7,670,981, other patents pending, and any foreign counterparts.

High Voltage X7R Dielectric, 500VDC-3000VDC (Commercial & Automotive Grade)

Overview

KEMET's high voltage surface mount MLCCs in X7R Dielectric feature a 125°C maximum operating temperature and are considered "temperature stable." The Electronics Components, Assemblies & Materials Association (EIA) characterizes X7R dielectric as a Class II material. Components of this classification are fixed, ceramic dielectric capacitors suited for bypass and decoupling applications or for frequency discriminating circuits where Q and stability of capacitance characteristics are not critical. X7R exhibits a predictable change in capacitance with respect to time and voltage and boasts a minimal change in capacitance with reference to ambient temperature. Capacitance change is limited to ±15% from -55°C to +125°C.

These devices offer low leakage current, exhibit low ESR at high frequencies and find conventional use as snubbers or filters in applications such as switching power supplies and in lighting ballasts. Their exceptional performance at high frequencies has made them a preferred choice of design engineers worldwide. In addition to their use in power supplies, these capacitors are widely used in industries related to automotive(hybrid), telecommunications, medical, military, aerospace, semiconductors and test/diagnostic equipment.

KEMET's high voltage surface mount MLCCs are manufactured in state of the art ISO/TS 16949:2002 certified facilities and are available in both commercial and automotive grades. Automotive grade devices meet the demanding Automotive Electronics Council's AEC-Q200 qualification requirements.

Benefits

- -55°C to +125°C operating temperature range
- Pb-Free and RoHS compliant
- EIA 0805, 1206, 1210, 1808, 1812, 1825, 2220 and 2225 case sizes
- DC voltage ratings of 500V, 630V, 1KV, 1.5KV, 2KV, 2.5KV and 3KV
- Capacitance offerings ranging from 10pF to 0.27µF
- Available capacitance tolerances of ±5%, ±10% and ±20%
- Low ESR and ESL
- Non-polar device, minimizing installation concerns
- Commercial & Automotive (AEC-Q200) grades available
- 100% pure matte tin-plated termination finish allowing for excellent solderability
- SnPb plated termination finish option available upon request (5% min)

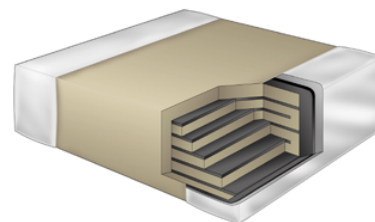

Ordering Information

C	1808	C	563	K	C	R	A	C	TU
Ceramic	Case Size (L" x W")	Specification/ Series	Capacitance Code (pF)	Capacitance Tolerance	Voltage	Dielectric	Failure Rate/ Design	Termination Finish ¹	Packaging/Grade (C-Spec) ²
	0805 1206 1210 1808 1812 1825 2220 2225	C = Standard	2 Sig. Digits + Number of Zeros	J = ±5% K = ±10% M = ±20%	C = 500V B = 630V D = 1000V F = 1500V G = 2000V Z = 2500V H = 3000V	R = X7R	A = N/A	C = 100% Matte Sn L = SnPb (5% min)	Blank = Bulk TU = 7" Reel Unmarked TM = 7" Reel Marked AUTO = Automotive Grade 7" Reel Unmarked

¹ SnPb termination finish option is not available on automotive grade product.

¹ Additional termination finish options may be available. Contact KEMET for details.

² Additional reeling or packaging options may be available. Contact KEMET for details.

Dimensions – Millimeters (Inches)

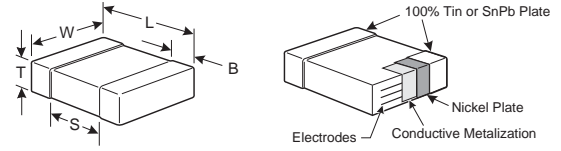

EIA Size Code	Metric Size Code	L Length	W Width	T Thickness	B Bandwidth	S Separation Min.	Mounting Technique
0805	2012	2.00 (.079) ± 0.20 (.008)	1.25 (.049) ± 0.20 (.008)	See Table 2 for Thickness	0.50 (0.02) ± 0.25 (.010)	0.75 (.030)	Solder Wave or Solder Reflow
1206	3216	3.20 (.126) ± 0.20 (.008)	1.60 (.063) ± 0.20 (.008)		0.50 (0.02) ± 0.25 (.010)	N/A	
1210	3225	3.20 (.126) ± 0.20 (.008)	2.50 (.098) ± 0.20 (.008)		0.50 (0.02) ± 0.25 (.010)		
1808	4520	4.70 (.185) ± 0.50 (.020)	2.00 (.079) ± 0.20 (.008)		0.60 (.024) ± 0.35 (.014)		Solder Reflow Only
1812	4532	4.50 (.177) ± 0.30 (.012)	3.20 (.126) ± 0.30 (.012)		0.60 (.024) ± 0.35 (.014)		
1825	4564	4.50 (.177) ± 0.30 (.012)	6.40 (.252) ± 0.40 (.016)		0.60 (.024) ± 0.35 (.014)		
2220	5650	5.70 (.224) ± 0.40 (.016)	5.00 (.197) ± 0.40 (.016)		0.60 (.024) ± 0.35 (.014)		
2225	5664	5.60 (.220) ± 0.40 (.016)	6.40 (.248) ± 0.40 (.016)		0.60 (.024) ± 0.35 (.014)		

Applications

Typical applications include switch mode power supplies (input filters, resonators, tank circuits, snubber circuits, output filters), high voltage coupling and DC blocking, lighting ballasts, voltage multiplier circuits, DC/DC converters and coupling capacitors in Ćuk converters. Markets include power supply, LCD fluorescent backlight ballasts, HID lighting, telecom equipment, industrial and medical equipment/control, LAN/WAN interface, analog and digital modems, and automotive. X7R dielectrics are not designed for AC line filtering applications.

Qualification/Certification

Commercial grade products are subject to internal qualification. Details regarding test methods and conditions are referenced in Table 4, Performance and Reliability.

Automotive grade products meet or exceed the requirements outlined by the Automotive Electronics Council. Details regarding test methods and conditions are referenced in document AEC-Q200, Stress Test Qualification for Passive Components. For additional information regarding the Automotive Electronics Council and AEC-Q200, please visit their website @www.aecouncil.com.

Environmental Compliance

Pb-Free and RoHS compliant (excluding SnPb termination finish option)

Electrical Parameters/Characteristics

Item	Parameters/Characteristics
Operating Temperature Range	-55°C to +125°C
Capacitance Change with Reference to +25°C and 0 Vdc Applied (TCC)	±15%
Aging Rate (Max % Cap Loss/Decade Hour)	3.0%
Dielectric Withstanding Voltage	150% of rated voltage for voltage rating of < 1000V 120% of rated voltage for voltage rating of ≥ 1000V (5 ± 1 seconds and charge/discharge not exceeding 50mA)
Dissipation Factor (DF) Maximum Limit @ 25°C	2.5%
Insulation Resistance (IR) Limit @ 25°C	1000 megohm microfarads or 100GΩ (Rated voltage applied for 120 ± 5 secs @ 25°C)

Regarding Aging Rate: Capacitance measurements (including tolerance) are indexed to a referee time of 1000 Hours.

To obtain IR limit, divide MΩ-μF value by the capacitance and compare to GΩ limit. Select the lower of the two limits.

Capacitance and Dissipation Factor (DF) measured under the following conditions:

1kHz ± 50Hz and 1.0 ± 0.2 Vrms if capacitance ≤ 10μF

120Hz ± 10Hz and 0.5 ± 0.1 Vrms if capacitance > 10μF

Note: When measuring capacitance it is important to ensure the set voltage level is held constant. The HP4284 & Agilent E4980 have a feature known as Automatic Level Control (ALC). The ALC feature should be switched to "ON".

Post Environmental Limits

High Temperature Life, Biased Humidity, Moisture Resistance					
Dielectric	Rated DC Voltage	Capacitance Value	DF (%)	Cap Shift	IR
X7R	>25	All	3.0	± 20%	10% of Initial Limit
	16 / 25		5.0		
	< 16		7.5		

Table 1A – High Voltage X7R Dielectric, (0805 - 1812 Case Sizes) con't

Cap	Cap Code	Series	C0805					C1206					C1210					C1808						C1812							
		Voltage Code	C	B	D	C	B	D	F	G	C	B	D	F	G	C	B	D	F	G	Z	H	C	B	D	F	G	Z	H		
		Voltage DC	500	630	1000	500	630	1000	1500	2000	500	630	1000	1500	2000	500	630	1000	1500	2000	2500	3000	500	630	1000	1500	2000	2500	3000		
		Cap Tolerance	Product Availability and Chip Thickness Codes - See Table 2 for Chip Thickness Dimensions																												
15,000 pF	153	J	K	M				EG	UD	UD				FL	FL	FL				LA	LC	LC				GH	GK	GK			
18,000 pF	183	J	K	M				UD	UD	UD				FL	FL	FL				LA	UD	UD				GH	GK	GK			
22,000 pF	223	J	K	M				UD	UD	UD				FL	FM	FM				LA	UD	UD				GH	GK	GK			
27,000 pF	273	J	K	M				UD	UD					FM	FK	FK				LA	UD	UD				GH	UD	UD			
33,000 pF	333	J	K	M				UD	UD					FM	UD	UD				LC	UD	UD				GH	UD	UD			
39,000 pF	393	J	K	M				UD						FK	UD	UD				LC	UD	UD				GH	UD	UD			
47,000 pF	473	J	K	M				UD						FK	UD	UD				LC	UD	UD				GH	UD	UD			
56,000 pF	563	J	K	M				UD						UD	UD	UD				LC	UD	UD				GH	UD	UD			
62,000 pF	623	J	K	M				UD						UD	UD	UD				UD	UD	UD				GK	UD	UD			
68,000 pF	683	J	K	M				UD						UD	UD	UD				UD	UD	UD				UD	UD	UD			
82,000 pF	823	J	K	M										UD	UD					UD	UD					UD	UD	UD			
0.10 μF	104	J	K	M										UD	UD					UD	UD					UD	UD	UD			
0.12 μF	124	J	K	M										UD						UD						UD	UD	UD			
0.15 μF	154	J	K	M										UD						UD						UD	UD	UD			
0.18 μF	184	J	K	M										UD						UD						UD	UD	UD			
0.22 μF	224	J	K	M										UD						UD						UD	UD	UD			
0.27 μF	274	J	K	M										UD						UD						UD	UD	UD			
0.33 μF	334	J	K	M										UD						UD						UD	UD	UD			
Cap	Cap Code	Voltage DC	500	630	1000	500	630	1000	1500	2000	500	630	1000	1500	2000	500	630	1000	1500	2000	2500	3000	500	630	1000	1500	2000	2500	3000		
Cap	Cap Code	Voltage Code	C	B	D	C	B	D	F	G	C	B	D	F	G	C	B	D	F	G	Z	H	C	B	D	F	G	Z	H		
Cap	Cap Code	Series	C0805					C1206					C1210					C1808						C1812							

Table 1B – (1825 - 2225 Case Sizes)

Cap	Cap Code	Series	C1825								C2220								C2225							
		Voltage Code	C	B	D	F	G	Z	H	C	B	D	F	G	Z	H	C	B	D	F	G	Z	H			
		Voltage DC	500	630	1000	1500	2000	2500	3000	500	630	1000	1500	2000	2500	3000	500	630	1000	1500	2000	2500	3000			
		Cap Tolerance	Product Availability and Chip Thickness Codes - See Table 2 for Chip Thickness Dimensions																							
100 pF	101	J	K	M	HG	HG	HG	HG	HG	HG	JP	JP	JP	JP	JP	JP	KF	KF	KF	KF	KF	KF				
110 pF	111	J	K	M	HG	HG	HG	HG	HG	HG	JP	JP	JP	JP	JP	JP	KF	KF	KF	KF	KF	KF				
120 pF	121	J	K	M	HG	HG	HG	HG	HG	HG	JP	JP	JP	JP	JP	JP	KF	KF	KF	KF	KF	KF				
130 pF	131	J	K	M	HG	HG	HG	HG	HG	HG	JP	JP	JP	JP	JP	JP	KF	KF	KF	KF	KF	KF				
150 pF	151	J	K	M	HG	HG	HG	HG	HG	HG	JP	JP	JP	JP	JP	JP	KF	KF	KF	KF	KF	KF				
180 pF	181	J	K	M	HG	HG	HG	HG	HG	HG	JP	JP	JP	JP	JP	JP	KF	KF	KF	KF	KF	KF				
220 pF	221	J	K	M	HE	HE	HE	HE	HE	HG	JP	JP	JP	JP	JP	JP	KF	KF	KF	KF	KF	KF				
270 pF	271	J	K	M	HE	HE	HE	HE	HE	HG	JP	JP	JP	JP	JP	JP	KE	KE	KE	KE	KE	KF				
330 pF	331	J	K	M	HG	HG	HG	HG	HG	HG	JP	JP	JP	JP	JP	JP	KE	KE	KE	KE	KE	KF				
390 pF	391	J	K	M	HG	HG	HG	HG	HG	HG	JP	JP	JP	JP	JP	JP	KE	KE	KE	KE	KE	KF				
470 pF	471	J	K	M	HG	HG	HG	HG	HG	HG	JP	JP	JP	JP	JP	JP	KF	KF	KF	KF	KF	KF				
560 pF	561	J	K	M	HG	HG	HG	HG	HG	HG	JP	JP	JP	JP	JP	JP	KF	KF	KF	KF	KF	KF				
680 pF	681	J	K	M	HG	HG	HG	HG	HG	HG	JP	JP	JP	JP	JP	JP	KF	KF	KF	KF	KF	KF				
820 pF	821	J	K	M	HG	HG	HG	HG	HG	HG	JP	JP	JP	JP	JP	JP	KF	KF	KF	KF	KF	KF				
1,000 pF	102	J	K	M	HG	HG	HG	HG	HG	HG	JP	JP	JP	JP	JP	JP	KF	KF	KF	KF	KF	KF				
1,200 pF	122	J	K	M	HG	HG	HG	HG	HG	HG	JP	JP	JP	JP	JP	JP	KF	KF	KF	KF	KF	KF				
1,500 pF	152	J	K	M	HG	HG	HG	HG	HG	HG	JP	JP	JP	JP	JP	JP	KF	KF	KF	KF	KF	KF				
1,800 pF	182	J	K	M	HE	HE	HE	HE	HE	HG	JP	JP	JP	JP	JP	JP	KF	KF	KF	KF	KF	KF				
2,000 pF	202	J	K	M	HE	HE	HE	HE	HG	HG	JE	JE	JE	JE	JP	JP	KF	KF	KF	KF	KF	KF				
2,200 pF	222	J	K	M	HE	HE	HE	HE	HG	HG	JE	JE	JE	JE	JP	JP	KF	KF	KF	KF	KF	KF				
Cap	Cap Code	Voltage DC	500	630	1000	1500	2000	2500	3000	500	630	1000	1500	2000	2500	3000	500	630	1000	1500	2000	2500	3000			
Cap	Cap Code	Voltage Code	C	B	D	F	G	Z	H	C	B	D	F	G	Z	H	C	B	D	F	G	Z	H			
Cap	Cap Code	Series	C1825								C2220								C2225							

UD = Under Development

KEMET reserves the right to substitute product with an improved temperature characteristic, tighter capacitance tolerance and/or higher voltage capability within the same form factor (configuration and dimensions).

Table 1B – High Voltage X7R Dielectric, (1825 - 2225 Case Sizes) con't

Cap	Cap Code	Series			C1825						C2220						C2225									
		Voltage Code			C	B	D	F	G	Z	H	C	B	D	F	G	Z	H	C	B	D	F	G	Z	H	
		Voltage DC			500	630	1000	1500	2000	2500	3000	500	630	1000	1500	2000	2500	3000	500	630	1000	1500	2000	2500	3000	
		Cap Tolerance			Product Availability and Chip Thickness Codes - See Table 2 for Chip Thickness Dimensions																					
2,700 pF	272	J	K	M	HE	HE	HE	HE	HE	HG	HG	JE	JE	JE	JE	JE	JP	JP	KE	KE	KE	KE	KE	KF	KF	
3,300 pF	332	J	K	M	HE	HE	HE	HE	HE	HG	HG	JE	JE	JE	JE	JE	JP	JP	KE	KE	KE	KE	KE	KF	KF	
3,900 pF	392	J	K	M	HE	HE	HE	HE	HE			JE	JE	JE	JE	JE	JP	JP	KE	KE	KE	KE	KE	KF	KF	
4,700 pF	472	J	K	M	HE	HE	HE	HE	HE			JE	JE	JE	JE	JP			KE	KE	KE	KE	KE	KF	KF	
5,600 pF	562	J	K	M	HE	HE	HE	HE	HE			JE	JE	JE	JE	JP			KE	KE	KE	KE	KE	KF	KF	
6,800 pF	682	J	K	M	HE	HE	HE	HE	HE			JE	JE	JE	JE	JP			KE	KE	KE	KE	KF			
8,200 pF	822	J	K	M	HE	HE	HE	HE	HE			JE	JE	JE	JE	JP			KE	KE	KE	KE	KF			
10,000 pF	103	J	K	M	HE	HE	HE	HE				JE	JE	JE	JE				KE	KE	KE	KE	KF			
12,000 pF	123	J	K	M	HE	HE	HE	HE	HG			JE	JP	JP	JP				KE	KE	KE	KE	KF			
15,000 pF	153	J	K	M	HE	HE	HE	HG				JE	JP	JP	JP				KE	KE	KE	KE				
18,000 pF	183	J	K	M	HE	HE	HE	HG				JE	JP	JP	JP				KE	KE	KE	KE				
22,000 pF	223	J	K	M	HE	HG	HG	HG				JE	JP	JP	JP				KE	KF	KF	KF				
27,000 pF	273	J	K	M	HE	HG	HG	HG				JE	JP	JP	JP				KE	KF	KF	KF				
33,000 pF	333	J	K	M	HE	HG	HG					JE	JP	JP	JP				KE	KF	KF	KF				
39,000 pF	393	J	K	M	HE	HG	HG					JE	JP	JP					KE	KF	KF	KF				
47,000 pF	473	J	K	M	HE	HG	HG					JE	JP	JP					KE	KF	KF	KF				
56,000 pF	563	J	K	M	HE							JE							KE	KF	KF					
62,000 pF	623	J	K	M	HG							JE							KE	KF	KF					
68,000 pF	683	J	K	M	HG							JE							KE	KF	KF					
82,000 pF	823	J	K	M	HG							JE							KE	KF	KF					
0.10 µF	104	J	K	M	HG							JE							KE							
0.12 µF	124	J	K	M	HG							JE							KE							
0.15 µF	154	J	K	M	HG							JP							KF							
0.18 µF	184	J	K	M	HG							JP							KF							
0.22 µF	224	J	K	M	HG							JP							KF							
0.27 µF	274	J	K	M															KF							
0.33 µF	334	J	K	M																						
0.39 µF	394	J	K	M																						
0.47 µF	474	J	K	M																						
0.56 µF	564	J	K	M																						
0.68 µF	684	J	K	M																						
0.82 µF	824	J	K	M																						
1.0 µF	105	J	K	M																						
1.2 µF	125	J	K	M																						
Cap	Cap Code	Voltage DC			500	630	1000	1500	2000	2500	3000	500	630	1000	1500	2000	2500	3000	500	630	1000	1500	2000	2500	3000	
		Voltage Code			C	B	D	F	G	Z	H	C	B	D	F	G	Z	H	C	B	D	F	G	Z	H	
		Series			C1825						C2220						C2225									

KEMET reserves the right to substitute product with an improved temperature characteristic, tighter capacitance tolerance and/or higher voltage capability within the same form factor (configuration and dimensions).

High Voltage with Flexible Termination System (HV FT-CAP) X7R Dielectric, 500VDC-3000VDC (Commercial & Automotive Grade)

Overview

KEMET’s High Voltage with Flexible Termination (HV FT-CAP) surface mount MLCCs in X7R dielectric combine high voltage and flexible termination technologies. Featuring a 125°C maximum operating temperature and considered “temperature stable,” these devices address the primary failure mode of MLCCs—flex cracks, which are typically the result of excessive shear stresses produced during board flexure or thermal cycling. Utilizing a conductive silver epoxy between the base metal and nickel barrier layers of KEMET’s standard termination system, flexible termination technology directs board flex stress away from the ceramic body and into the termination area, therefore mitigating flex cracks which can result in low IR or short circuit failures. Although flexible termination technology does not eliminate the potential for mechanical damage that may propagate during extreme environmental and handling conditions, it does provide superior flex performance over standard termination systems.

The HV FT-CAP offers low leakage current, exhibits low ESR at high frequencies and finds conventional use as snubbers or filters in applications such as switching power supplies and lighting

ballasts. Their exceptional performance at high frequencies has made them a preferred choice of design engineers worldwide. In addition to their use in power supplies, these capacitors are widely used in industries related to automotive(hybrid), telecommunications, medical, military, aerospace, semiconductors and test/diagnostic equipment.

Combined with the stability of an X7R dielectric and designed to accommodate all capacitance requirements, these flex-robust devices are RoHS-compliant, offer up to 5mm of flex-bend capability and exhibit a predictable change in capacitance with respect to time and voltage. Capacitance change with reference to ambient temperature is limited to ±15% from -55°C to +125°C.

KEMET’s high voltage surface mount MLCCs are manufactured in state of the art ISO/TS 16949:2002 certified facilities and are available in both commercial and automotive grades. Automotive grade devices meet the demanding Automotive Electronics Council's AEC-Q200 qualification requirements.

HIGH VOLTAGE
FLEXIBLE
FTCAP
TERMINATION

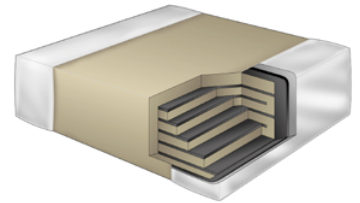

Ordering Information

C	1210	X	473	K	C	R	A	C	TU
Ceramic	Case Size (L" x W")	Specification/ Series	Capacitance Code (pF)	Capacitance Tolerance	Voltage	Dielectric	Failure Rate/ Design	Termination Finish ¹	Packaging/Grade (C-Spec) ²
	0805 1206 1210 1808 1812 1825 2220 2225	X = Flexible Termination	2 Sig. Digits + Number of Zeros	J = ±5% K = ±10% M = ±20%	C = 500V B = 630V D = 1000V F = 1500V G = 2000V Z = 2500V H = 3000V	R = X7R	A = N/A	C = 100% Matte Sn L = SnPb (5% min)	Blank = Bulk TU = 7" Reel Unmarked TM = 7" Reel Marked AUTO = Automotive Grade 7" Reel Unmarked

¹ SnPb termination finish option is not available on automotive grade product.

¹ Additional termination finish options may be available. Contact KEMET for details.

Dimensions – Millimeters (Inches)

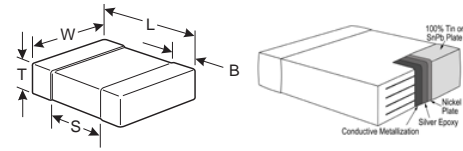

EIA Size Code	Metric Size Code	L Length	W Width	T Thickness	B Bandwidth	S Separation Min.	Mounting Technique
0805	2012	2.10 (.083) +0.30 (.012) / -0.20 (.008)	1.25 (.049) ± 0.20 (.008)	See Table 2 for Thickness	0.50 (0.02) +0.10(.004)/ -0.25 (.010)	0.70 (.028)	Solder Wave or Solder Reflow
1206	3216	3.30 (.130) ± 0.40 (.016)	1.60 (.063) ± 0.20 (.008)		0.60 (.024) ± 0.25 (.010)	N/A	
1210	3225	3.30 (.130) ± 0.40 (.016)	2.50 (.098) ± 0.20 (.008)		0.60 (.024) ± 0.25 (.010)		
1808	4520	4.70 (.185) ± 0.50 (.020)	2.00 (.079) ± 0.20 (.008)		0.70 (.028) ± 0.35 (.014)		
1812	4532	4.50 (.178) ± 0.40 (.016)	3.20 (.126) ± 0.30 (.012)		0.70 (.028) ± 0.35 (.014)		
1825	4564	4.60 (.181) ± 0.40 (.016)	6.40 (.252) ± 0.40 (.016)		0.70 (.028) ± 0.35 (.014)		
2220	5650	5.90 (.232) ± 0.75 (.030)	5.00 (.197) ± 0.40 (.016)		0.70 (.028) ± 0.35 (.014)		
2225	5664	5.90 (.232) ± 0.75 (.030)	6.40 (.248) ± 0.40 (.016)		0.70 (.028) ± 0.35 (.014)		Solder Reflow Only

Benefits

- -55°C to +125°C operating temperature range
- Superior flex performance (up to 5mm)
- Pb-Free and RoHS compliant
- EIA 0805, 1206, 1210, 1808, 1812, 1825, 2220 and 2225 case sizes
- DC voltage ratings of 500V, 630V, 1KV, 1.5KV, 2KV, 2.5KV and 3KV
- Capacitance offerings ranging from 62pF to 0.27µF
- Available capacitance tolerances of ±5%, ±10% or ±20%.
- Low ESR and ESL
- Non-polar device, minimizing installation concerns
- Commercial & Automotive (AEC-Q200) grades available
- 100% pure matte tin-plated termination finish allowing for excellent solderability
- SnPb plated termination finish option available upon request (5% min)

Applications

Typical applications include switch mode power supplies (input filters, resonators, tank circuits, snubber circuits, output filters), high voltage coupling and DC blocking, lighting ballasts, voltage multiplier circuits, DC/DC converters and coupling capacitors in Ćuk converters. Markets include power supply, LCD fluorescent backlight ballasts, HID lighting, telecom equipment, industrial and medical equipment/control, LAN/WAN interface, analog and digital modems, and automotive. X7R dielectrics are not designed for AC line filtering or pulse applications.

Qualification/Certification

Commercial grade products are subject to internal qualification. Details regarding test methods and conditions are referenced in Table 4, Performance and Reliability.

Automotive grade products meet or exceed the requirements outlined by the Automotive Electronics Council. Details regarding test methods and conditions are referenced in document AEC-Q200, Stress Test Qualification for Passive Components. For additional information regarding the Automotive Electronics Council and AEC-Q200, please visit their website @www.aecouncil.com.

Environmental Compliance

Pb-Free and RoHS compliant (excluding SnPb termination finish option)

Electrical Parameters/Characteristics

Item	Parameters/Characteristics
Operating Temperature Range	-55°C to +125°C
Capacitance Change with Reference to +25°C and 0 Vdc Applied (TCC)	±15%
Aging Rate (Max % Cap Loss/Decade Hour)	3.0%
Dielectric Withstanding Voltage	150% of rated voltage for voltage rating of < 1000V 120% of rated voltage for voltage rating of ≥ 1000V (5 ± 1 seconds and charge/discharge not exceeding 50mA)
Dissipation Factor (DF) Maximum Limit @ 25°C	2.5%
Insulation Resistance (IR) Limit @ 25°C	1000 megohm microfarads or 100GΩ (Rated voltage applied for 120 ± 5 secs @ 25°C)

Regarding Aging Rate: Capacitance measurements (including tolerance) are indexed to a referee time of 1000 Hours.

To obtain IR limit, divide MΩ-μF value by the capacitance and compare to GΩ limit. Select the lower of the two limits.

Capacitance and Dissipation Factor (DF) measured under the following conditions:

1kHz ± 50Hz and 1.0 ± 0.2 Vrms if capacitance ≤ 10μF

120Hz ± 10Hz and 0.5 ± 0.1 Vrms if capacitance > 10μF

Note: When measuring capacitance it is important to ensure the set voltage level is held constant. The HP4284 & Agilent E4980 have a feature known as Automatic Level Control (ALC). The ALC feature should be switched to "ON".

Post Environmental Limits

High Temperature Life, Biased Humidity, Moisture Resistance					
Dielectric	Rated DC Voltage	Capacitance Value	DF (%)	Cap Shift	IR
X7R	>25	All	3.0	± 20%	10% of Initial Limit
	16 / 25		5.0		
	< 16		7.5		

Table 1A – (HV FT-CAP), X7R Dielectric, (0805 - 1812 Case Sizes)

Cap	Cap Code	Series	C0805					C1206					C1210					C1808						C1812										
		Voltage Code	C	B	D	C	B	D	F	G	C	B	D	F	G	C	B	D	F	G	Z	H	C	B	D	F	G	Z	H					
		Voltage DC	500	630	1000	500	630	1000	1500	2000	500	630	1000	1500	2000	500	630	1000	1500	2000	2500	3000	500	630	1000	1500	2000	2500	3000					
		Cap Tolerance	Product Availability and Chip Thickness Codes - See Table 2 for Chip Thickness Dimensions																															
56 pF	560	J K M																																
62 pF	620	J K M	DG	DG	DG																													
68 pF	680	J K M	DG	DG	DG																													
75 pF	750	J K M	DG	DG	DG	EG	EG	EG	EG	EG												LB	LB	LB	LB	LB	LB	LB						
82 pF	820	J K M	DG	DG	DG	EG	EG	EG	EG	EG												LB	LB	LB	LB	LB	LB	LB						
91 pF	910	J K M	DG	DG	DG	EG	EG	EG	EG	EG												LB	LB	LB	LB	LB	LB	LB						
100 pF	101	J K M	DG	DG	DG	EG	EG	EG	EG	EG												LB	LB	LB	LB	LB	LB	LB						
110 pF	111	J K M	DG	DG	DG	EF	EF	EF	EF	EG												LB	LB	LB	LB	LB	LB	LB						
120 pF	121	J K M	DG	DG	DG	EF	EF	EF	EF	EG												LA	LA	LA	LA	LA	LA	LA						
130 pF	131	J K M	DG	DG	DG	EF	EF	EF	EF	EG	FL	FL	FL	FL	FL							LA	LA	LA	LA	LB	LB	LB						
150 pF	151	J K M	DG	DG	DG	EF	EF	EF	EF	EG	FL	FL	FL	FL	FL	LA	LA	LA	LA	LB	LB	LB	LB	LB	LB	LB	GK	GK	GK	GK	GK	GK	GK	
180 pF	181	J K M	DG	DG	DG	EF	EF	EF	EF	EG	FL	FL	FL	FL	FL	LA	LA	LA	LA	LB	LB	LB	LB	LB	LB	LB	LB	GK	GK	GK	GK	GK	GK	GK
220 pF	221	J K M	DG	DG	DG	EF	EF	EF	EF	EG	FL	FL	FL	FL	FL	LA	LA	LA	LA	LB	LB	LB	LB	LB	LB	LB	LB	GK	GK	GK	GK	GK	GK	GK
270 pF	271	J K M	DG	DG	DG	EF	EF	EF	EF	EG	FL	FL	FL	FL	FL	LA	LA	LA	LA	LB	LB	LB	LB	LB	LB	LB	LB	GK	GK	GK	GK	GK	GK	GK
330 pF	331	J K M	DG	DG	DG	EF	EF	EF	EF	EG	FL	FL	FL	FL	FL	LA	LA	LA	LA	LB	LB	LB	LB	LB	LB	LB	LB	GK	GK	GK	GK	GK	GK	GK
390 pF	391	J K M	DG	DG	DG	EF	EF	EF	EF	EG	FL	FL	FL	FL	FL	LA	LA	LA	LA	LB	LB	LB	LB	LB	LB	LB	LB	GK	GK	GK	GK	GK	GK	GK
470 pF	471	J K M	DG	DG	DG	EF	EF	EF	EF	EG	FL	FL	FL	FL	FL	LA	LA	LA	LA	LB	LB	LB	LB	LB	LB	LB	LB	GK	GK	GK	GK	GK	GK	GK
560 pF	561	J K M	DG	DG	DG	EF	EF	EF	EF	EG	FL	FL	FL	FL	FL	LA	LA	LA	LA	LB	LB	LB	LB	LB	LB	LB	LB	GK	GK	GK	GK	GK	GK	GK
680 pF	681	J K M	DG	DG	DG	EF	EF	EF	EF	EG	FL	FL	FL	FL	FL	LA	LA	LA	LA	LB	LB	LB	LB	LB	LB	LB	LB	GK	GK	GK	GK	GK	GK	GK
820 pF	821	J K M	DG	DG	DG	EF	EF	EF	EF	EG	FL	FL	FL	FL	FL	LA	LA	LA	LA	LB	LB	LB	LB	LB	LB	LB	LB	GK	GK	GK	GK	GK	GK	GK
1,000 pF	102	J K M	DG	DG	DG	EF	EF	EF	EF	EG	FL	FL	FL	FL	FL	LA	LA	LA	LA	LB	LB	LB	LB	LB	LB	LB	LB	GK	GK	GK	GK	GK	GK	GK
1,200 pF	122	J K M	DG	DG	DG	EF	EF	EF	EG	EG	FL	FL	FL	FL	FM	LB	LB	LB	LB	LB	LB	LB	LB	LB	LB	LB	LB	GK	GK	GK	GK	GK	GK	GK
1,500 pF	152	J K M	DG	DG	DG	EF	EF	EF	EG	EG	FL	FL	FL	FL	FM	LA	LA	LA	LB	LB	LB	LB	LB	LB	LB	LB	LB	GK	GK	GK	GK	GK	GK	GK
1,800 pF	182	J K M	DG	DG	DG	EF	EF	EF	EG	EG	FL	FL	FL	FL	FM	LA	LA	LA	LB	LB	LB	LB	LB	LB	LB	LB	LB	GK	GK	GK	GK	GK	GK	GK
2,000 pF	202	J K M	DG	DG	DG	EF	EF	EF	EG	EG	FL	FL	FL	FL	FM	LA	LA	LA	LB	LB	LB	LB	LB	LB	LB	LB	LB	GK	GK	GK	GK	GK	GK	GK
2,200 pF	222	J K M	DG	DG	DG	EF	EF	EF	EG	EG	FL	FL	FL	FL	FM	LA	LA	LA	LB	LB	LB	LB	LB	LB	LB	LB	LB	GK	GK	GK	GK	GK	GK	GK
2,700 pF	272	J K M	DG	DG	DG	EF	EF	EF	EG	EG	FL	FL	FL	FL	FM	LA	LA	LA	LB	LB	LB	LB	LB	LB	LB	LB	LB	GK	GK	GK	GK	GK	GK	GK
3,300 pF	332	J K M	DG	DG	DG	EF	EF	EF	EG	EG	FL	FL	FL	FL	FM	LA	LA	LA	LB	LB	LB	LB	LB	LB	LB	LB	LB	GK	GK	GK	GK	GK	GK	GK
3,900 pF	392	J K M	DG	UD	UD	EF	EF	EF	EG	EG	FL	FL	FL	FL	FK	LA	LA	LA	LB	LB	LB	LB	LB	LB	LB	LB	LB	GK	GK	GK	GK	GK	GK	GK
4,700 pF	472	J K M	DG	UD	UD	EF	EF	EF	EG	EG	FL	FL	FL	FL	FK	LA	LA	LA	LB	LB	LB	LB	LB	LB	LB	LB	LB	GK	GK	GK	GK	GK	GK	GK
5,600 pF	562	J K M	DG	UD	UD	EF	EF	EF			FL	FL	FL	FM		LA	LB	LB	LB	LB	LB	LB	LB	LB	LB	LB	GK	GK	GK	GK	GK	GK	GK	
6,800 pF	682	J K M	DG	UD	UD	EG	EG	EG			FL	FL	FL	FM		LA	LB	LB	LB	LB	LB	LB	LB	LB	LB	LB	GK	GK	GK	GK	GK	GK	GK	
8,200 pF	822	J K M	DG	UD	UD	EG	EG	EG			FL	FL	FL	FK		LA	LB	LB	LB	LB	LB	LB	LB	LB	LB	LB	GK	GK	GK	GK	GK	GK	GK	
10,000 pF	103	J K M	UD			EG	EG	EG			FL	FL	FL	FK		LA	LB	LB	LB	LB	LB	LB	LB	LB	LB	LB	GK	GK	GK	GK	GK	GK	GK	
12,000 pF	123	J K M	UD			EG	UD	UD			FL	FL	FL	FK		LA	LC	LC									GK	GK	GK	GK	GK	GK	GK	GK
15,000 pF	153	J K M				EG	UD	UD			FL	FL	FL			LA	LC	LC									GK	GK	GK	GK	GK	GK	GK	GK
18,000 pF	183	J K M				UD	UD	UD			FL	FL	FL			LA	UD	UD									GK	GK	GK	GK	GK	GK	GK	GK
22,000 pF	223	J K M				UD	UD	UD			FL	FM	FM			LA	UD	UD									GK	GK	GK	GK	GK	GK	GK	GK
27,000 pF	273	J K M				UD	UD	UD			FM	FK	FK			LA	UD	UD									GK	GK	GK	GK	GK	GK	GK	GK
33,000 pF	333	J K M				UD	UD				FM	UD	UD			LC	UD	UD									GK	GK	GK	GK	GK	GK	GK	GK
39,000 pF	393	J K M				UD					FK	UD	UD			LC	UD	UD									GK	GK	GK	GK	GK	GK	GK	GK
47,000 pF	473	J K M				UD					FK	UD	UD			LC	UD	UD									GK	GK	GK	GK	GK	GK	GK	GK
56,000 pF	563	J K M				UD					UD	UD	UD			LC	UD	UD									GK	GK	GK	GK	GK	GK	GK	GK
62,000 pF	623	J K M				UD					UD	UD	UD			UD	UD	UD									GK	GK	GK	GK	GK	GK	GK	GK
68,000 pF	683	J K M				UD					UD	UD	UD			UD	UD	UD									GK	GK	GK	GK	GK	GK	GK	GK
82,000 pF	823	J K M				UD					UD	UD				UD	UD										GK	GK	GK	GK	GK	GK	GK	GK
0.10 μF	104	J K M				UD					UD	UD				UD	UD										GK	GK	GK	GK	GK	GK	GK	GK
0.12 μF	124	J K M				UD					UD					UD											GK	GK	GK	GK	GK	GK	GK	GK
0.15 μF	154	J K M				UD					UD					UD											GK	GK	GK	GK	GK	GK	GK	GK
0.18 μF	184	J K M				UD					UD					UD											GK	GK	GK	GK	GK	GK	GK	GK
0.22 μF	224	J K M				UD					UD					UD											GK	GK	GK	GK	GK	GK	GK	GK
0.27 μF	274	J K M				UD					UD					UD											GK	GK	GK	GK	GK	GK	GK	GK
0.33 μF	334	J K M				UD					UD					UD											GK	GK	GK	GK	GK	GK	GK	GK
Cap	Cap Code	Voltage DC	500	630	1000	500	630	1000	1500	2000	500	630	1000	1500	2000	500	630	1000	1500	2000	2500	3000	500	630	1000	1500	2000	2500	3000					
		Voltage Code	C	B	D	C	B	D	F	G	C	B	D	F	G	C	B	D	F	G	Z	H	C	B	D	F	G	Z	H					
		Series	C0805			C1206					C1210					C1808						C1812												

UD = Under Development

KEMET reserves the right to substitute product with an improved temperature characteristic, tighter capacitance tolerance and/or higher voltage capability within the same form factor (configuration and dimensions).

KPS HV, Large Case, SM Series, C0G Dielectric, 500VDC-10KVDC (Industrial Grade)

Overview

KPS HV (KEMET Power Solutions, High Voltage), Large Case (≥ 1515), SM Series capacitors in C0G dielectric are designed to meet robust performance standards required in higher reliability industrial applications. Utilizing lead-frame technology, SM Series devices isolate the multilayer ceramic chip component from the printed circuit board providing advanced mechanical and thermal stress performance. Isolation of the chip component also addresses concerns for audible, microphonic noise that may occur when a bias voltage is applied. Although this technology does not eliminate the potential for mechanical damage that may propagate during extreme environmental and handling conditions, it does demonstrate superior performance over non-isolating systems. Available in both formed "L" and "J" lead configurations, SM Series devices offer up to 10mm of board flex capability and

exhibit lower ESR, ESL and higher current discharge capability when compared to other dielectric solutions.

Combined with the stability of an C0G dielectric, KEMET's High Voltage SM Series devices exhibit no change in capacitance with respect to time and voltage and boasts a negligible change in capacitance with reference to ambient temperature. Capacitance change is limited to $\pm 30\text{ppm}/^\circ\text{C}$ from -55°C to $+125^\circ\text{C}$.

KEMET's Industrial grade products offer additional screening options for higher reliability applications. Both Group A and Group B testing/inspection options per MIL-PRF-49467 are available for the SM Series.

Benefits

- -55°C to $+125^\circ\text{C}$ operating temperature range
- Large Case Sizes (≥ 1515)
- Formed "L" or "J" leadframe configurations.
- Group A & B screening per MIL-PRF-49467 available
- Reliable & robust leadframe termination system
- DC voltage ratings of 500V, 1KV, 2KV, 3KV, 4KV, 5KV, 7.5KV & 10KV
- Capacitance offerings ranging from 10pF up to 0.39 μF
- Advanced protection against thermal & mechanical stress
- Provides up to 10mm of board flex capability
- Reduces audible, microphonic noise
- Low ESR & ESL
- Non-polar device, minimizing installation concerns
- Silver plated copper alloy leadframe termination system

Applications

Typical applications include switch mode power supplies (input filters, resonators, tank circuits, snubber circuits, output filters), high voltage coupling and DC blocking, voltage multiplier circuits, DC/DC converters and coupling capacitors in Ćuk converters, noise reduction (piezoelectric/mechanical), circuits with a direct battery or power source connection, critical and safety relevant circuits without (integrated) current limitation and any application that is subject to high levels of board flexure or temperature cycling. Markets include power supply, LCD fluorescent backlight ballasts, HID lighting, telecom equipment, industrial and medical equipment/control and Military.



Ordering Information

SM20		N	472	J	501	B	M
Style/Size		Dielectric	Capacitance Code (pF)	Capacitance Tolerance	Voltage	Lead Configuration ¹	Testing/ Inspection Option ²
SM20	SM30	N = C0G	2 Sig. Digits + Number of Zeros.	J = $\pm 5\%$ K = $\pm 10\%$ M = $\pm 20\%$ P = $+100\%$, -0% Z = $+80\%$, -20%	501 = 500V	A = Formed "L" B = Formed "J"	Blank = None M = Group A per MIL-PRF-49467
SM21	SM31				102 = 1000V		
SM22	SM33				202 = 2000V		
SM23	SM34				302 = 3000V		
SM24	SM35				402 = 4000V		
SM25	SM36				502 = 5000V		
SM26							

¹ Standard lead configuration is formed "J". If the appropriate character is excluded from the ordering code, the assumed lead configuration will be formed "J".

² Group B testing/inspection option per MIL-PRF-49467 is available upon request. Please contact KEMET for ordering details.

Dimensions – Inches (Millimeters)

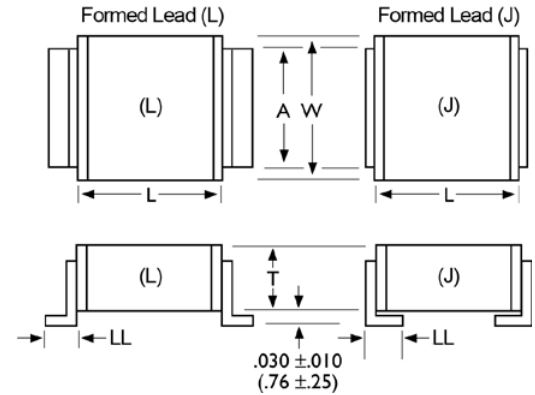

Style/ Size	L Length	W Width	T Thickness Max.	A Lead Width Max.	LL Lead Length (Formed "L")	LL Lead Length (Formed "J")
SM20	0.150 ± 0.015 (3.81 ± 0.38)	0.150 ± 0.015 (3.81 ± 0.38)	0.130 (3.30)	0.100 (2.54)	0.100 ± 0.020 (2.54 ± 0.51)	0.040 ± 0.010 (1.02 ± 0.25)
SM21	0.200 ± 0.020 (5.08 ± 0.51)	0.200 ± 0.020 (5.08 ± 0.51)	0.180 (4.57)			
SM22	0.250 ± 0.020 (6.35 ± 0.51)	0.200 ± 0.020 (5.08 ± 0.51)	0.220 (5.59)			0.200 (5.08)
SM23	0.350 ± 0.030 (8.89 ± 0.76)	0.300 ± 0.030 (7.62 ± 0.76)		0.300 (7.62)		
SM24	0.450 ± 0.030 (11.43 ± 0.76)	0.400 ± 0.030 (10.20 ± 0.76)		0.400 (10.20)		
SM25	0.550 ± 0.030 (14.00 ± 0.76)	0.500 ± 0.030 (12.70 ± 0.76)	0.140 (3.55)	0.500 (12.70)		0.100 ± 0.020 (2.54 ± 0.51)
SM26	0.650 ± 0.030 (16.50 ± 0.76)	0.600 ± 0.030 (15.20 ± 0.76)		0.130 (3.30)		
SM30	0.300 ± 0.030 (7.62 ± 0.76)	0.150 ± 0.015 (3.81 ± 0.38)		0.220 (5.59)	0.200 (5.08)	
SM31	0.400 ± 0.030 (10.20 ± 0.76)	0.200 ± 0.020 (5.08 ± 0.51)	0.300 (7.62)			
SM33	0.700 ± 0.030 (17.08 ± 0.76)	0.300 ± 0.030 (7.62 ± 0.76)	0.400 (10.2)			
SM34	0.900 ± 0.030 (22.90 ± 0.76)	0.400 ± 0.030 (10.20 ± 0.76)	0.180 (4.57)	0.500 (12.7)	0.100 ± 0.020 (2.54 ± 0.51)	
SM35	1.100 ± 0.030 (27.90 ± 0.76)	0.500 ± 0.030 (12.70 ± 0.76)		0.300 (7.62)		
SM36	1.350 ± 0.030 (33.00 ± 0.76)	0.600 ± 0.030 (15.20 ± 0.76)		0.400 (10.2)		

Qualification/Certification

Industrial Grade products are subject to internal qualification. Details regarding test methods and conditions are referenced in Table 3 , Performance and Reliability.

Environmental Compliance

RoHS compliant with Exemption(s)

Electrical Parameters/Characteristics

Item	Parameters/Characteristics
Operating Temperature Range	-55°C to +125°C
Capacitance Change with Reference to +25°C and 0 VDC Applied (TCC)	±30PPM/°C
Aging Rate (Max % Cap Loss/Decade Hour)	0%
Dielectric Withstanding Voltage	150% of rated voltage for voltage rating of ≤ 1250Vdc 120% of rated voltage for voltage rating of > 1250Vdc (5 ± 1 seconds and charge/discharge not exceeding 50mA)
Dissipation Factor (DF) Maximum Limits @ 25°C	0.15%
Insulation Resistance (IR) Limit @ 25°C	1000 megohm microfarads or 100GΩ (Rated voltage DC applied for 120 ± 5 secs @ 25°C for voltage rating of ≤ 500VDC) (500VDC applied for 120 ± 5 secs @ 25°C for voltage rating of > 500VDC)

To obtain IR limit, divide MΩ-μF value by the capacitance and compare to GΩ limit. Select the lower of the two limits.

Capacitance and Dissipation Factor (DF) measured under the following conditions:

1MHz ± 100kHz and 1.0Vrms ± 0.2V if capacitance ≤ 100pF

1kHz ± 50Hz and 1.0Vrms ± 0.2V if capacitance > 100pF

Note: When measuring capacitance it is important to ensure the set voltage level is held constant. The HP4284 & Agilent E4980 have a feature known as Automatic Level Control (ALC). The ALC feature should be switched to "ON".

Post Environmental Limits

High Temperature Life, Biased Humidity, Moisture Resistance				
Dielectric	Rated DC Voltage	Capacitance Value	DF (%)	Cap Shift
C0G	All	All	0.25	0.3% or ± 0.25 pf

Table 1A – SM20 - SM24 Style/Size

Style/Size	SM20				SM21				SM22				SM23				SM24					Cap Tol				
Dimensions - In. (mm)																										
Length	0.150 ± 0.015 (3.81 ± 0.38)				0.200 ± 0.020 (5.08 ± 0.51)				0.250 ± 0.020 (6.35 ± 0.51)				0.350 ± 0.030 (8.89 ± 0.76)				0.450 ± 0.030 (11.43 ± 0.76)									
Width	0.150 ± 0.015 (3.81 ± 0.38)				0.200 ± 0.020 (5.08 ± 0.51)				0.200 ± 0.020 (5.08 ± 0.51)				0.300 ± 0.030 (7.62 ± 0.76)				0.400 ± 0.030 (10.20 ± 0.76)									
Thickness Max.	0.130 (3.30)				0.180 (4.57)				0.180 (4.57)				0.220 (5.59)				0.220 (5.59)									
Lead Width Max.	0.100 (2.54)				0.100 (2.54)				0.100 (2.54)				0.200 (5.08)				0.300 (7.62)									
Lead Length "L"	0.100 ± 0.020 (2.54 ± 0.51)				0.100 ± 0.020 (2.54 ± 0.51)				0.100 ± 0.020 (2.54 ± 0.51)				0.100 ± 0.020 (2.54 ± 0.51)				0.100 ± 0.020 (2.54 ± 0.51)									
Lead Length "J"	0.040 ± 0.010 (1.02 ± 0.25)				0.040 ± 0.010 (1.02 ± 0.25)				0.040 ± 0.010 (1.02 ± 0.25)				0.100 ± 0.020 (2.54 ± 0.51)				0.100 ± 0.020 (2.54 ± 0.51)									
COG Dielectric																										
Voltage Code	501	102	202	302	501	102	202	302	501	102	202	302	501	102	202	302	402	501	102	202	302	402	502	Cap Tol		
Voltage DC	500	1K	2K	3K	500	1K	2K	3K	500	1K	2K	3K	500	1K	2K	3K	4K	500	1K	2K	3K	4K	5K			
Capacitance	Capacitance Code																									
22pF								220	220																	
27pF								270	270																	
33pF								330	330	330	330	330	330											330	330	
39pF	390	390	390	390	390	390	390	390	390	390	390	390	390											390	390	
47pF	470	470	470	470	470	470	470	470	470	470	470	470	470											470	470	
56pF	560	560	560	560	560	560	560	560	560	560	560	560	560										560	560	560	
68pF	680	680	680	680	680	680	680	680	680	680	680	680	680										680	680	680	
82pF	820	820	820	820	820	820	820	820	820	820	820	820	820	820	820	820	820	820	820	820	820	820	820	820	820	
100pF	101	101	101	101	101	101	101	101	101	101	101	101	101	101	101	101	101	101	101	101	101	101	101	101	101	
120pF	121	121	121	121	121	121	121	121	121	121	121	121	121	121	121	121	121	121	121	121	121	121	121	121	121	
150pF	151	151	151	151	151	151	151	151	151	151	151	151	151	151	151	151	151	151	151	151	151	151	151	151	151	
180pF	181	181	181	181	181	181	181	181	181	181	181	181	181	181	181	181	181	181	181	181	181	181	181	181	181	
220pF	221	221	221	221	221	221	221	221	221	221	221	221	221	221	221	221	221	221	221	221	221	221	221	221	221	
270pF	271	271	271	271	271	271	271	271	271	271	271	271	271	271	271	271	271	271	271	271	271	271	271	271	271	
330pF	331	331	331		331	331	331	331	331	331	331	331	331	331	331	331	331	331	331	331	331	331	331	331	331	
390pF	391	391	391		391	391	391	391	391	391	391	391	391	391	391	391	391	391	391	391	391	391	391	391	391	
470pF	471	471	471		471	471	471	471	471	471	471	471	471	471	471	471	471	471	471	471	471	471	471	471	471	
560pF	561	561	561		561	561	561	561	561	561	561	561	561	561	561	561	561	561	561	561	561	561	561	561	561	
680pF	681	681	681		681	681	681	681	681	681	681	681	681	681	681	681	681	681	681	681	681	681	681	681	681	
820pF	821	821	821		821	821	821	821	821	821	821	821	821	821	821	821	821	821	821	821	821	821	821	821	821	
1,000pF	102	102			102	102	102		102	102	102	102	102	102	102	102	102	102	102	102	102	102	102	102	102	
1,200pF	122	122			122	122	122		122	122	122	122	122	122	122	122	122	122	122	122	122	122	122	122	122	
1,500pF	152	152			152	152	152		152	152	152	152	152	152	152	152	152	152	152	152	152	152	152	152	152	
1,800pF	182	182			182	182	182		182	182	182	182	182	182	182	182	182	182	182	182	182	182	182	182	182	
2,200pF	222	222			222	222	222		222	222	222	222	222	222	222	222	222	222	222	222	222	222	222	222	222	
2,700pF	272	272			272	272			272	272	272			272	272	272			272	272	272	272			272	
3,300pF					332	332			332	332	332			332	332	332			332	332	332	332			332	
3,900pF					392	392			392	392			392	392	392			392	392	392	392			392	392	
4,700pF					472	472			472	472			472	472	472			472	472	472	472			472	472	
5,600pF									562	562			562	562	562			562	562	562			562	562	562	
6,800pF									682	682			682	682			682	682	682			682	682	682	682	
8,200pF									822				822	822			822	822	822			822	822	822	822	
0.01µF									103				103	103			103	103	103			103	103	103	103	
0.012µF									123				123	123			123	123			123	123			123	
0.015µF									153				153	153			153	153			153	153			153	
0.018µF									183				183				183	183			183	183			183	
0.022µF													223				223	223			223	223			223	
0.027µF													273				273	273			273	273			273	
0.033µF													333				333	333			333	333			333	
0.039µF																	393	393			393	393			393	
0.047µF																	473	473			473			473	473	
0.039µF																	393				393			393	393	
0.047µF																	473				473			473	473	

Table 1B – SM25 - SM31 Style/Size

Style/Size	SM25					SM26					SM30					SM31					Cap Tol				
Dimensions - In. (mm)																									
Length	0.550 ± 0.030 (14.00 ± 0.76)					0.650 ± 0.030 (16.50 ± 0.76)					0.300 ± 0.030 (7.62 ± 0.76)					0.400 ± 0.030 (10.20 ± 0.76)									
Width	0.500 ± 0.030 (12.70 ± 0.76)					0.600 ± 0.030 (15.20 ± 0.76)					0.150 ± 0.015 (3.81 ± 0.38)					0.200 ± 0.020 (5.08 ± 0.51)									
Thickness Max.	0.220 (5.59)					0.220 (5.59)					0.140 (3.55)					0.130 (3.30)									
Lead Width Max.	0.400 (10.20)					0.500 (12.70)					0.100 (2.54)					0.100 (2.54)									
Lead Length "L"	0.100 ± 0.020 (2.54 ± 0.51)					0.100 ± 0.020 (2.54 ± 0.51)					0.100 ± 0.020 (2.54 ± 0.51)					0.100 ± 0.020 (2.54 ± 0.51)									
Lead Length "J"	0.100 ± 0.020 (2.54 ± 0.51)					0.100 ± 0.020 (2.54 ± 0.51)					0.100 ± 0.020 (2.54 ± 0.51)					0.100 ± 0.020 (2.54 ± 0.51)									
COG Dielectric																									
Voltage Code	501	102	202	302	402	502	501	102	202	302	402	502	501	102	202	302	402	501	102	202	302	402	502	Cap Tol	
Voltage DC	500	1K	2K	3K	4K	5K	500	1K	2K	3K	4K	5K	500	1K	2K	3K	4K	500	1K	2K	3K	4K	5K		
Capacitance	Capacitance Code																								
10pF																									
12pF																									
15pF													150	150	150	150	150								
18pF													180	180	180	180	180								
22pF													220	220	220	220	220								
27pF													270	270	270	270	270	270	270	270	270	270	270		
33pF													330	330	330	330	330	330	330	330	330	330	330		
39pF													390	390	390	390	390	390	390	390	390	390	390		
47pF													470	470	470	470	470	470	470	470	470	470	470		
56pF													560	560	560	560	560	560	560	560	560	560	560		
68pF													680	680	680	680	680	680	680	680	680	680	680		
82pF													820	820	820	820	820	820	820	820	820	820	820		
100pF												101	101	101	101	101	101	101	101	101	101	101	101		
120pF												121	121	121	121	121	121	121	121	121	121	121	121		
150pF												151	151	151	151	151	151	151	151	151	151	151	151		
180pF			181	181	181	181	181	181	181	181	181	181	181	181	181	181	181	181	181	181	181	181	181		
220pF			221	221	221	221	221	221	221	221	221	221	221	221	221	221	221	221	221	221	221	221			
270pF	271	271	271	271	271	271	271	271	271	271	271	271	271	271	271	271	271	271	271	271	271	271			
330pF	331	331	331	331	331	331	331	331	331	331	331	331	331	331	331	331	331	331	331	331	331	331			
390pF	391	391	391	391	391	391	391	391	391	391	391	391	391	391	391	391	391	391	391	391	391	391			
470pF	471	471	471	471	471	471	471	471	471	471	471	471	471	471	471	471	471	471	471	471	471	471			
560pF	561	561	561	561	561	561	561	561	561	561	561	561	561	561	561	561	561	561	561	561	561	561			
680pF	681	681	681	681	681	681	681	681	681	681	681	681	681	681	681	681	681	681	681	681	681	681			
820pF	821	821	821	821	821	821	821	821	821	821	821	821	821	821	821	821	821	821	821	821	821	821			
1,000pF	102	102	102	102	102	102	102	102	102	102	102	102	102	102	102	102	102	102	102	102	102	102			
1,200pF	122	122	122	122	122	122	122	122	122	122	122	122	122	122	122	122	122	122	122	122	122	122			
1,500pF	152	152	152	152	152	152	152	152	152	152	152	152	152	152	152	152	152	152	152	152	152	152			
1,800pF	182	182	182	182	182	182	182	182	182	182	182	182	182	182	182	182	182	182	182	182	182	182			
2,200pF	222	222	222	222	222	222	222	222	222	222	222	222	222	222	222	222	222	222	222	222	222	222			
2,700pF	272	272	272	272	272	272	272	272	272	272	272	272	272	272	272	272	272	272	272	272	272	272			
3,300pF	332	332	332	332	332	332	332	332	332	332	332	332	332	332	332	332	332	332	332	332	332	332			
3,900pF	392	392	392	392	392	392	392	392	392	392	392	392	392	392	392	392	392	392	392	392	392	392			
4,700pF	472	472	472	472	472	472	472	472	472	472	472	472	472	472	472	472	472	472	472	472	472	472			
5,600pF	562	562	562	562	562	562	562	562	562	562	562	562	562	562	562	562	562	562	562	562	562	562			
6,800pF	682	682	682	682	682	682	682	682	682	682	682	682	682	682	682	682	682	682	682	682	682	682			
8,200pF	822	822	822	822	822	822	822	822	822	822	822	822	822	822	822	822	822	822	822	822	822	822			
0.01µF	103	103	103	103	103	103	103	103	103	103	103	103	103	103	103	103	103	103	103	103	103	103			
0.012µF	123	123	123	123	123	123	123	123	123	123	123	123	123	123	123	123	123	123	123	123	123	123			
0.015µF	153	153	153	153	153	153	153	153	153	153	153	153	153	153	153	153	153	153	153	153	153	153			
0.018µF	183	183	183	183	183	183	183	183	183	183	183	183	183	183	183	183	183	183	183	183	183	183			
0.022µF	223	223	223	223	223	223	223	223	223	223	223	223	223	223	223	223	223	223	223	223	223	223			
0.027µF	273	273	273	273	273	273	273	273	273	273	273	273	273	273	273	273	273	273	273	273	273	273			
0.033µF	333	333	333	333	333	333	333	333	333	333	333	333	333	333	333	333	333	333	333	333	333	333			
0.039µF	393	393	393	393	393	393	393	393	393	393	393	393	393	393	393	393	393	393	393	393	393	393			
0.047µF	473	473	473	473	473	473	473	473	473	473	473	473	473	473	473	473	473	473	473	473	473	473			
0.056µF							563	563	563	563	563	563	563	563	563	563	563	563	563	563	563	563			
0.068µF							683	683	683	683	683	683	683	683	683	683	683	683	683	683	683	683			

Table 1C – SM33 - SM35 Style/Size

Style/Size	SM33							SM34							SM35							Cap Tol		
Dimensions - In. (mm)																								
Length	0.700 ± 0.030 (17.08 ± 0.76)							0.900 ± 0.030 (22.90 ± 0.76)							1.100 ± 0.030 (27.90 ± 0.76)									
Width	0.300 ± 0.030 (7.62 ± 0.76)							0.400 ± 0.030 (10.20 ± 0.76)							0.500 ± 0.030 (12.70 ± 0.76)									
Thickness Max.	0.180 (4.57)							0.220 (5.59)							0.220 (5.59)									
Lead Width Max.	0.200 (5.08)							0.300 (7.62)							0.400 (10.2)									
Lead Length "L"	0.100 ± 0.020 (2.54 ± 0.51)							0.100 ± 0.020 (2.54 ± 0.51)							0.100 ± 0.020 (2.54 ± 0.51)									
Lead Length "J"	0.100 ± 0.020 (2.54 ± 0.51)							0.100 ± 0.020 (2.54 ± 0.51)							0.100 ± 0.020 (2.54 ± 0.51)									
COG Dielectric																								
Voltage Code	501	102	202	302	402	502	752	501	102	202	302	402	502	752	103	501	102	202	302	402	502	752	103	Cap Tol
Voltage DC	500	1K	2K	3K	4K	5K	7.5K	500	1K	2K	3K	4K	5K	7.5K	10K	500	1K	2K	3K	4K	5K	7.5K	10K	
Capacitance	Capacitance Code																							
27pF							270	270																
33pF							330	330																
39pF							390	390																
47pF							470	470																
56pF							560	560																470
68pF							680	680	680	680	680	680	680	680	680	680	680	680	680	680	680	680	680	
82pF	820	820	820	820	820	820	820	820	820	820	820	820	820	820	820	820	820	820	820	820	820	820	820	
100pF	101	101	101	101	101	101	101	101	101	101	101	101	101	101	101	101	101	101	101	101	101	101	101	
120pF	121	121	121	121	121	121	121	121	121	121	121	121	121	121	121	121	121	121	121	121	121	121	121	
150pF	151	151	151	151	151	151	151	151	151	151	151	151	151	151	151	151	151	151	151	151	151	151	151	
180pF	181	181	181	181	181	181	181	181	181	181	181	181	181	181	181	181	181	181	181	181	181	181	181	
220pF	221	221	221	221	221	221	221	221	221	221	221	221	221	221	221	221	221	221	221	221	221	221	221	
270pF	271	271	271	271	271	271	271	271	271	271	271	271	271	271	271	271	271	271	271	271	271	271	271	
330pF	331	331	331	331	331	331	331	331	331	331	331	331	331	331	331	331	331	331	331	331	331	331	331	
390pF	391	391	391	391	391	391	391	391	391	391	391	391	391	391	391	391	391	391	391	391	391	391	391	
470pF	471	471	471	471	471	471	471	471	471	471	471	471	471	471	471	471	471	471	471	471	471	471	471	
560pF	561	561	561	561	561	561	561	561	561	561	561	561	561	561	561	561	561	561	561	561	561	561	561	
680pF	681	681	681	681	681	681	681	681	681	681	681	681	681	681	681	681	681	681	681	681	681	681	681	
820pF	821	821	821	821	821	821	821	821	821	821	821	821	821	821	821	821	821	821	821	821	821	821	821	
1,000pF	102	102	102	102	102	102	102	102	102	102	102	102	102	102	102	102	102	102	102	102	102	102	102	102
1,200pF	122	122	122	122	122	122		122	122	122	122	122	122	122	122	122	122	122	122	122	122	122	122	122
1,500pF	152	152	152	152	152	152		152	152	152	152	152	152	152	152	152	152	152	152	152	152	152	152	152
1,800pF	182	182	182	182	182	182		182	182	182	182	182	182	182	182	182	182	182	182	182	182	182	182	182
2,200pF	222	222	222	222	222	222		222	222	222	222	222	222	222	222	222	222	222	222	222	222	222	222	222
2,700pF	272	272	272	272	272	272		272	272	272	272	272	272	272	272	272	272	272	272	272	272	272	272	272
3,300pF	332	332	332	332				332	332	332	332													
3,900pF	392	392	392	392				392	392	392	392													
4,700pF	472	472	472	472				472	472	472	472													
5,600pF	562	562	562	562				562	562	562	562													
6,800pF	682	682	682	682				682	682	682	682													
8,200pF	822	822	822					822	822	822	822													
0.01µF	103	103	103					103	103	103	103													
0.012µF	123	123	123					123	123	123	123													
0.015µF	153	153	153					153	153	153	153													
0.018µF	183	183	183					183	183	183														
0.022µF	223	223						223	223	223														
0.027µF	273	273						273	273															
0.033µF	333	333						333	333															
0.039µF	393	393						393	393															
0.047µF	473	473						473	473															
0.056µF	563							563	563															
0.068µF	683							683																
0.082µF	823							823																
0.1µF	104							104																
0.12µF								124																
0.15µF								154																
0.18µF																								
0.22µF																								
0.27µF																								

Table 1D – SM36 Style/Size

Style/Size	SM36								Cap Tol
Dimensions - In. (mm)									
Length	1.350 ± 0.030 (33.00 ± 0.76)								
Width	0.600 ± 0.030 (15.20 ± 0.76)								
Thickness Max.	0.220 (5.59)								
Lead Width Max.	0.500 (12.7)								
Lead Length "L"	0.100 ± 0.020 (2.54 ± 0.51)								
Lead Length "J"	0.100 ± 0.020 (2.54 ± 0.51)								
COG Dielectric									
Voltage Code	501	102	202	302	402	502	752	103	Cap Tol
Voltage DC	500	1K	2K	3K	4K	5K	7.5K	10K	
Capacitance	Capacitance Code								J, K M, P Z
120pF					121	121	121		
150pF	151	151	151	151	151	151	151		
180pF	181	181	181	181	181	181	181		
220pF	221	221	221	221	221	221	221		
270pF	271	271	271	271	271	271	271		
330pF	331	331	331	331	331	331	331		
390pF	391	391	391	391	391	391	391		
470pF	471	471	471	471	471	471	471		
560pF	561	561	561	561	561	561	561		
680pF	681	681	681	681	681	681	681		
820pF	821	821	821	821	821	821	821		
1,000pF	102	102	102	102	102	102	102	102	
1,200pF	122	122	122	122	122	122	122		
1,500pF	152	152	152	152	152	152	152	152	
1,800pF	182	182	182	182	182	182	182		
2,200pF	222	222	222	222	222	222	222		
2,700pF	272	272	272	272	272	272	272		
3,300pF	332	332	332	332	332	332	332		
3,900pF	392	392	392	392	392	392			
4,700pF	472	472	472	472	472	472			
5,600pF	562	562	562	562	562	562			
6,800pF	682	682	682	682	682	682			
8,200pF	822	822	822	822	822				
0.01µF	103	103	103	103	103				
0.012µF	123	123	123	123					
0.015µF	153	153	153	153					
0.018µF	183	183	183	183					
0.022µF	223	223	223	223					
0.027µF	273	273	273	273					
0.033µF	333	333	333	333					
0.039µF	393	393	393						
0.047µF	473	473	473						
0.056µF	563	563	563						
0.068µF	683	683							
0.082µF	823	823							
0.1µF	104	104							
0.12µF	124	124							
0.15µF	154	154							
0.18µF	184								
0.22µF	224								
0.27µF	274								
0.33µF	334								
0.39µF	394								

Table 2 – Chip Thickness / Packaging Quantities

Series	Style/Size	Tray Quantity Min. ¹	Tray Quantity Max. ¹
SM	SM20	1	50
	SM21		
	SM22		
	SM23		
	SM24		
	SM25		
	SM26		
	SM30		
	SM31		
	SM33		25
	SM34		10
	SM35		
	SM36		

¹ Minimum order value applies. Contact KEMET for details.

Soldering Process

The capacitors and assemblies outlined in this specification sheet are susceptible to thermal shock damage due to their large ceramic mass. Temperature profiles used should provide adequate temperature rise and cool-down time to prevent damage from thermal shock. In general, KEMET recommends against hand soldering for these types of large ceramic devices.

Recommended Soldering Technique:

- Solder reflow only

Preheating and Reflow Profile Notes:

Due to differences in the coefficient of thermal expansion for the different materials of construction, it is critical to monitor and control the heating and cooling rates during the soldering process. During the reflow soldering process, the maximum recommended heating and cooling rate (dT/dt) is 4°C/second. To ensure optimal component reliability, KEMET's recommended heating and cooling rate is 2°C/second. After soldering, the capacitors should be air cooled to room temperature before further processing. Forced air cooling is not recommended.

Recommended Reflow Soldering Profile:

Profile Feature	SnPb Assembly
Preheat/Soak	
Temperature Min (T_{smin})	100°C
Temperature Max (T_{smax})	150°C
Time (t_s) from T_{smin} to T_{smax}	60-90 sec
Ramp-up Rate (T_L to T_p)	2°C/sec
Liquidous Temperature (T_L)	183°C
Time Above Liquidous (t_L)	95 sec
Peak Temperature (T_p)	240°C
Time within 5°C of Max Peak Temperature (t_p)	5 sec
Ramp-down Rate (T_p to T_L)	2°C/sec
Time 25°C to Peak Temperature	3.5 minutes

Note 1: All temperatures refer to the center of the package, measured on the package body surface that is facing up during assembly reflow.

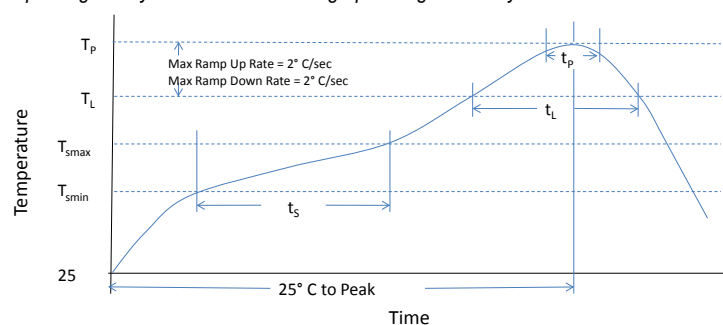

Construction

Reference	Item	Material
A	Leadframe	Phosphor Bronze - Alloy 510 (Silver plated / Nickle Underplate)
B	Leadframe Attach Material	Silver Epoxy
C	MLCC Termination System	Solderable Silver
D		
E		
F	Electrode	PdAg
G	Dielectric	BaTiO ₃

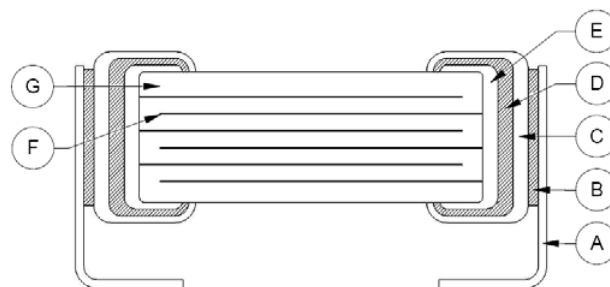

Note: Image is exaggerated in order to clearly identify all components of construction

Product Marking

Product marking is an extra-cost option. These devices will be supplied unmarked unless otherwise specified and/or requested. For more detailed information regarding marked product and how to request this option, please contact KEMET.

Table 3 – Performance & Reliability: Test Methods and Conditions

Stress	Reference	Test or Inspection Method
Board Flex	JIS-C-6429	Appendix 2, Note: 2 mm (min) for all except 3 mm for C0G.
Solderability	J-STD-002	Magnification 50 X. Conditions:
		a) Method B, 4 hours @ 155°C, dry heat @ 235°C
		b) Method B @ 215°C category 3
		c) Method D, category 3 @ 260°C
		1000 cycles (-55°C to +125°C). Measurement at 24 hours +/- 2 hours after test conclusion.
Biased Humidity	MIL-STD-202 Method 103	Load Humidity: 1000 hours 85°C/85%RH and 300VDC Max. Add 100K ohm resistor. Measurement at 24 hrs. +/- 2 hrs after test conclusion.
		Low Volt Humidity: 1000 hours 85°C/85%RH and 1.5V. Add 100K ohm resistor. Measurement at 24 hrs. +/- 2 hrs after test conclusion.
		t = 24 hours/cycle. Steps 7a & 7b not required. Unpowered. Measurement at 24 hours. +/- 2 hours after test conclusion.
Thermal Shock	MIL-STD-202 Method 107	-55°C/+125°C. Note: Number of cycles required – 300. Maximum transfer time – 20 seconds. D14 dwell time – 15 minutes. Air-Air.
High Temperature Life	MIL-STD-202 Method 108 / EIA -198	1000 hours at 125°C (85°C for X5R, Z5U and Y5V) with rated voltage applied.
Storage Life	MIL-STD-202 Method 108	150°C, 0VDC, for 1000 hours.
Vibration	MIL-STD-202 Method 204	5 g for 20 min., 12 cycles each of 3 orientations. Note: Use 8"X5" PCB .031" thick 7 secure points on one long side and 2 secure points at corners of opposite sides. Parts mounted within 2" from any secure point. Test from 10–2000 Hz.
Resistance to Soldering Heat	MIL-STD-202 Method 210	Condition B. No preheat of samples. Note: single wave solder – procedure 2.
Terminal Strength	MIL-STD-202 Method 211	Conditions A (2.3kg or 5lbs).
Mechanical Shock	MIL-STD-202 Method 213	Figure 1 of Method 213, Condition F.
Resistance to Solvents	MIL-STD-202 Method 215	Add aqueous wash chemical – OKEM Clean or equivalent.

Storage and Handling

Ceramic chip capacitors should be stored in normal working environments. While the chips themselves are quite robust in other environments, solderability will be degraded by exposure to high temperatures, high humidity, corrosive atmospheres, and long term storage. In addition, packaging materials will be degraded by high temperature – reels may soften or warp, and tape peel force may increase. KEMET recommends that maximum storage temperature not exceed 40°C, and maximum storage humidity not exceed 70% relative humidity. In addition, temperature fluctuations should be minimized to avoid condensation on the parts, and atmospheres should be free of chlorine and sulfur bearing compounds. For optimized solderability, chip stock should be used promptly, preferably within 1.5 years of receipt.

KPS HV, Large Case, SM Series, X7R Dielectric, 500VDC-10KVDC (Industrial Grade)

Overview

KPS HV (KEMET Power Solutions, High Voltage), Large Case (≥ 1515), SM Series capacitors in X7R dielectric are designed to meet robust performance standards required in higher reliability industrial applications. Utilizing lead-frame technology, SM Series devices isolate the multilayer ceramic chip component from the printed circuit board providing advanced mechanical and thermal stress performance. Isolation of the chip component also addresses concerns for audible, microphonic noise that may occur when a bias voltage is applied. Although this technology does not eliminate the potential for mechanical damage that may propagate during extreme environmental and handling conditions, it does demonstrate superior performance over non-isolating systems. Available in both formed "L" and "J" lead configurations, SM Series devices offer up to 10mm of board flex capability and

exhibit lower ESR, ESL and higher current discharge capability when compared to other dielectric solutions.

Combined with the stability of an X7R dielectric, KEMET's High Voltage SM Series devices exhibit a predictable change in capacitance with respect to time and voltage and boast a minimal change in capacitance with reference to ambient temperature. Capacitance change is limited to $\pm 15\%$ from -55°C to $+125^{\circ}\text{C}$.

KEMET's Industrial grade products offer additional screening options for higher reliability applications. Both Group A and Group B testing/inspection options per MIL-PRF-49467 are available for the SM Series.

Benefits

- -55°C to $+125^{\circ}\text{C}$ operating temperature range
- Large Case Sizes (≥ 1515)
- Formed "L" or "J" leadframe configurations
- Group A & B screening per MIL-PRF-49467 available
- Reliable & robust leadframe termination system
- DC voltage ratings of 500V, 1KV, 2KV, 3KV, 4KV, 5KV, 7.5KV & 10KV
- Capacitance offerings ranging from 150pF up to 5.6 μF
- Advanced protection against thermal & mechanical stress
- Provides up to 10mm of board flex capability
- Reduces audible, microphonic noise
- Low ESR & ESL
- Non-polar device, minimizing installation concerns
- Silver plated copper alloy leadframe termination system

Applications

Typical applications include switch mode power supplies (input filters, resonators, tank circuits, snubber circuits, output filters), high voltage coupling and DC blocking, voltage multiplier circuits, DC/DC converters and coupling capacitors in Ćuk converters, noise reduction (piezoelectric/mechanical), circuits with a direct battery or power source connection, critical and safety relevant circuits without (integrated) current limitation and any application that is subject to high levels of board flexure or temperature cycling. Markets include power supply, LCD fluorescent backlight ballasts, HID lighting, telecom equipment, industrial and medical equipment/control and Military.



Ordering Information

SM20		B	153	K	501	B	M
Style/Size		Dielectric	Capacitance Code (pF)	Capacitance Tolerance	Voltage	Lead Configuration ¹	Testing/ Inspection Option ²
SM20	SM30	B = X7R	2 Sig. Digits + Number of Zeros.	K = $\pm 10\%$ M = $\pm 20\%$ P = $+100\%$, -0% Z = $+80\%$, -20%	501 = 500V	A = Formed "L" B = Formed "J"	Blank = None M = Group A per MIL-PRF-49467
SM21	SM31				102 = 1000V		
SM22	SM33				202 = 2000V		
SM23	SM34				302 = 3000V		
SM24	SM35				402 = 4000V		
SM25	SM36				502 = 5000V		
SM26							

¹ Standard lead configuration is formed "J". If the appropriate character is excluded from the ordering code, the assumed lead configuration will be formed "J".

² Group B testing/inspection option per MIL-PRF-49467 is available upon request. Please contact KEMET for ordering details.

Dimensions – Inches (Millimeters)

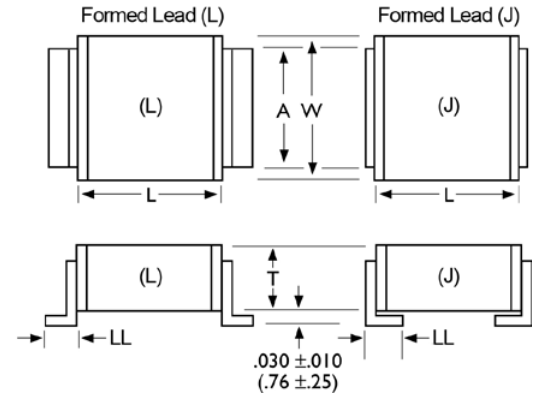

Style/ Size	L Length	W Width	T Thickness Max.	A Lead Width Max.	LL Lead Length (Formed "L")	LL Lead Length (Formed "J")	
SM20	0.150 ± 0.015 (3.81 ± 0.38)	0.150 ± 0.015 (3.81 ± 0.38)	0.130 (3.30)	0.100 (2.54)	0.100 ± 0.020 (2.54 ± 0.51)	0.040 ± 0.010 (1.02 ± 0.25)	
SM21	0.200 ± 0.020 (5.08 ± 0.51)	0.200 ± 0.020 (5.08 ± 0.51)	0.180 (4.57)				
SM22	0.250 ± 0.020 (6.35 ± 0.51)	0.200 ± 0.020 (5.08 ± 0.51)	0.220 (5.59)	0.200 (5.08)		0.100 ± 0.020 (2.54 ± 0.51)	
SM23	0.350 ± 0.030 (8.89 ± 0.76)	0.300 ± 0.030 (7.62 ± 0.76)		0.300 (7.62)			
SM24	0.450 ± 0.030 (11.43 ± 0.76)	0.400 ± 0.030 (10.20 ± 0.76)		0.400 (10.20)			
SM25	0.550 ± 0.030 (14.00 ± 0.76)	0.500 ± 0.030 (12.70 ± 0.76)		0.500 (12.70)			
SM26	0.650 ± 0.030 (16.50 ± 0.76)	0.600 ± 0.030 (15.20 ± 0.76)	0.140 (3.55)	0.100 (2.54)			0.100 ± 0.020 (2.54 ± 0.51)
SM30	0.300 ± 0.030 (7.62 ± 0.76)	0.150 ± 0.015 (3.81 ± 0.38)	0.130 (3.30)				
SM31	0.400 ± 0.030 (10.20 ± 0.76)	0.200 ± 0.020 (5.08 ± 0.51)	0.180 (4.57)	0.200 (5.08)			
SM33	0.700 ± 0.030 (17.08 ± 0.76)	0.300 ± 0.030 (7.62 ± 0.76)	0.220 (5.59)	0.300 (7.62)			
SM34	0.900 ± 0.030 (22.90 ± 0.76)	0.400 ± 0.030 (10.20 ± 0.76)		0.400 (10.2)			
SM35	1.100 ± 0.030 (27.90 ± 0.76)	0.500 ± 0.030 (12.70 ± 0.76)		0.500 (12.7)			
SM36	1.350 ± 0.030 (33.00 ± 0.76)	0.600 ± 0.030 (15.20 ± 0.76)					

Qualification/Certification

Industrial Grade products are subject to internal qualification. Details regarding test methods and conditions are referenced in Table 3 , Performance and Reliability.

Environmental Compliance

RoHS compliant with Exemption(s)

Electrical Parameters/Characteristics

Item	Parameters/Characteristics
Operating Temperature Range	-55°C to +125°C
Capacitance Change with Reference to +25°C and 0 VDC Applied (TCC)	±15%
Aging Rate (Max % Cap Loss/Decade Hour)	3.0%
Dielectric Withstanding Voltage	150% of rated voltage for voltage rating of ≤ 1250Vdc 120% of rated voltage for voltage rating of > 1250Vdc (5 ± 1 seconds and charge/discharge not exceeding 50mA)
Dissipation Factor (DF) Maximum Limits @ 25°C	2.5%
Insulation Resistance (IR) Limit @ 25°C	1000 megohm microfarads or 100GΩ (Rated voltage DC applied for 120 ± 5 secs @ 25°C for voltage rating of ≤ 500VDC) (500VDC applied for 120 ± 5 secs @ 25°C for voltage rating of > 500VDC)

Regarding Aging Rate: Capacitance measurements (including tolerance) are indexed to a referee time of 1000 hours.

To obtain IR limit, divide $M\Omega\text{-}\mu F$ value by the capacitance and compare to $G\Omega$ limit. Select the lower of the two limits.

Capacitance and Dissipation Factor (DF) measured under the following conditions:

1kHz ± 50Hz and 1.0Vrms ± 0.2V if capacitance >100pF

Note: When measuring capacitance it is important to ensure the set voltage level is held constant. The HP4284 & Agilent E4980 have a feature known as Automatic Level Control (ALC). The ALC feature should be switched to "ON".

Post Environmental Limits

High Temperature Life, Biased Humidity, Moisture Resistance				
Dielectric	Rated DC Voltage	Capacitance Value	DF (%)	Cap Shift
X7R	All	All	3.0	± 20%

Table 1A – SM20 - SM24 Style/Size

Style/Size	SM20			SM21			SM22			SM23				SM24					Cap Tol				
Dimensions - Inches (mm)																							
Length	0.150 ± 0.015 (3.81 ± 0.38)			0.200 ± 0.020 (5.08 ± 0.51)			0.250 ± 0.020 (6.35 ± 0.51)			0.350 ± 0.030 (8.89 ± 0.76)				0.450 ± 0.030 (11.43 ± 0.76)									
Width	0.150 ± 0.015 (3.81 ± 0.38)			0.200 ± 0.020 (5.08 ± 0.51)			0.200 ± 0.020 (5.08 ± 0.51)			0.300 ± 0.030 (7.62 ± 0.76)				0.400 ± 0.030 (10.20 ± 0.76)									
Thickness Max.	0.130 (3.30)			0.180 (4.57)			0.180 (4.57)			0.220 (5.59)				0.220 (5.59)									
Lead Width Max.	0.100 (2.54)			0.100 (2.54)			0.100 (2.54)			0.200 (5.08)				0.300 (7.62)									
Lead Length "L"	0.100 ± 0.020 (2.54 ± 0.51)			0.100 ± 0.020 (2.54 ± 0.51)			0.100 ± 0.020 (2.54 ± 0.51)			0.100 ± 0.020 (2.54 ± 0.51)				0.100 ± 0.020 (2.54 ± 0.51)									
Lead Length "J"	0.040 ± 0.010 (1.02 ± 0.25)			0.040 ± 0.010 (1.02 ± 0.25)			0.040 ± 0.010 (1.02 ± 0.25)			0.100 ± 0.020 (2.54 ± 0.51)				0.100 ± 0.020 (2.54 ± 0.51)									
X7R Dielectric																							
Voltage Code	501	102	202	501	102	202	302	501	102	202	302	501	102	202	302	402	501	102	202	302	402	502	Cap Tol
Voltage DC	500	1K	2K	500	1K	2K	3K	500	1K	2K	3K	500	1K	2K	3K	4K	500	1K	2K	3K	4K	5K	
Capacitance	Capacitance Code																						
270pF																							
330pF	331	331	331																				
390pF	391	391	391																				
470pF	471	471	471																				
560pF	561	561	561																				
680pF	681	681	681					681	681	681	681												
820pF	821	821	821	821	821	821	821	821	821	821	821												
1,000pF	102	102	102	102	102	102	102	102	102	102	102	102	102	102	102	102	102	102	102	102	102	102	102
1,200pF	122	122	122	122	122	122	122	122	122	122	122	122	122	122	122	122	122	122	122	122	122	122	122
1,500pF	152	152	152	152	152	152	152	152	152	152	152	152	152	152	152	152	152	152	152	152	152	152	152
1,800pF	182	182	182	182	182	182	182	182	182	182	182	182	182	182	182	182	182	182	182	182	182	182	182
2,200pF	222	222	222	222	222	222	222	222	222	222	222	222	222	222	222	222	222	222	222	222	222	222	222
2,700pF	272	272	272	272	272	272	272	272	272	272	272	272	272	272	272	272	272	272	272	272	272	272	272
3,300pF	332	332	332	332	332	332	332	332	332	332	332	332	332	332	332	332	332	332	332	332	332	332	332
3,900pF	392	392	392	392	392	392	392	392	392	392	392	392	392	392	392	392	392	392	392	392	392	392	392
4,700pF	472	472		472	472	472	472	472	472	472	472	472	472	472	472	472	472	472	472	472	472	472	472
5,600pF	562	562		562	562	562		562	562	562	562		562	562	562	562	562	562	562	562	562	562	562
6,800pF	682	682		682	682	682		682	682	682		682	682	682	682	682	682	682	682	682	682	682	682
8,200pF	822	822		822	822	822		822	822	822		822	822	822	822	822	822	822	822	822	822	822	822
0.01µF	103	103		103	103	103		103	103	103		103	103	103	103	103	103	103	103	103	103	103	103
0.012µF	123	123		123	123	123		123	123	123		123	123	123	123	123	123	123	123	123	123	123	123
0.015µF	153	153		153	153			153	153	153		153	153	153	153			153	153	153	153		
0.018µF	183	183		183	183			183	183			183	183	183			183	183	183	183			
0.022µF	223	223		223	223			223	223			223	223	223			223	223	223	223			
0.027µF	273			273	273			273	273			273	273	273			273	273	273	273			
0.033µF	333			333	333			333	333			333	333	333			333	333	333	333			
0.039µF	393			393	393			393	393			393	393			393	393	393	393				
0.047µF	473			473	473			473	473			473	473			473	473	473	473				
0.056µF	563			563	563			563	563			563	563			563	563	563	563				
0.068µF	683			683	683			683	683			683	683			683	683	683	683				
0.082µF	823			823				823	823			823	823			823	823	823	823				
0.1µF				104				104	104			104	104			104	104	104					
0.12µF				124				124				124	124			124	124						
0.15µF				154				154				154	154			154	154						
0.18µF				184				184				184	184			184	184						
0.22µF								224				224	224			224	224						
0.27µF								274				274	274			274							
0.33µF												334			334			334	334				
0.39µF												394			394			394	394				
0.47µF												474			474			474	474				
0.56µF												564					564						
0.68µF																684							
0.82µF																824							
1.0µF																105							
1.2µF																125							

Table 1B – SM25 - SM31 Style/Size

Style/Size	SM25					SM26					SM30					SM31					Cap Tol				
Dimensions - In. (mm)																									
Length	0.550 ± 0.030 (14.00 ± 0.76)					0.650 ± 0.030 (16.50 ± 0.76)					0.300 ± 0.030 (7.62 ± 0.76)					0.400 ± 0.030 (10.20 ± 0.76)									
Width	0.500 ± 0.030 (12.70 ± 0.76)					0.600 ± 0.030 (15.20 ± 0.76)					0.150 ± 0.015 (3.81 ± 0.38)					0.200 ± 0.020 (5.08 ± 0.51)									
Thickness Max.	0.220 (5.59)					0.220 (5.59)					0.140 (3.55)					0.130 (3.30)									
Lead Width Max.	0.400 (10.20)					0.500 (12.70)					0.100 (2.54)					0.100 (2.54)									
Lead Length "L"	0.100 ± 0.020 (2.54 ± 0.51)					0.100 ± 0.020 (2.54 ± 0.51)					0.100 ± 0.020 (2.54 ± 0.51)					0.100 ± 0.020 (2.54 ± 0.51)									
Lead Length "J"	0.100 ± 0.020 (2.54 ± 0.51)					0.100 ± 0.020 (2.54 ± 0.51)					0.100 ± 0.020 (2.54 ± 0.51)					0.100 ± 0.020 (2.54 ± 0.51)									
X7R Dielectric																									
Voltage Code	501	102	202	302	402	502	501	102	202	302	402	502	501	102	202	302	402	501	102	202	302	402	502	Cap Tol	
Voltage DC	500	1K	2K	3K	4K	5K	500	1K	2K	3K	4K	5K	500	1K	2K	3K	4K	500	1K	2K	3K	4K	5K		
Capacitance	Capacitance Code																								
150pF													151	151	151	151	151								
180pF													181	181	181	181	181								
220pF													221	221	221	221	221								
270pF													271	271	271	271	271								
330pF													331	331	331	331	331								
390pF													391	391	391	391	391								
470pF													471	471	471	471	471								
560pF													561	561	561	561	561								
680pF													681	681	681	681	681	681	681	681	681	681	681	681	
820pF													821	821	821	821	821	821	821	821	821	821	821	821	
1,000pF													102	102	102	102	102	102	102	102	102	102	102	102	
1,200pF													122	122	122	122	122	122	122	122	122	122	122	122	
1,500pF													152	152	152	152	152	152	152	152	152	152	152	152	
1,800pF													182	182	182	182	182	182	182	182	182	182	182	182	
2,200pF	222	222	222	222	222	222	222	222	222	222			222	222	222	222	222	222	222	222	222	222	222	222	
2,700pF	272	272	272	272	272	272	272	272	272	272			272	272	272	272	272	272	272	272	272	272	272	272	
3,300pF	332	332	332	332	332	332	332	332	332	332			332	332	332	332	332	332	332	332	332	332	332	332	
3,900pF	392	392	392	392	392	392	392	392	392	392	392	392	392	392	392	392	392	392	392	392	392	392	392	392	
4,700pF	472	472	472	472	472	472	472	472	472	472	472	472	472	472	472	472	472	472	472	472	472	472	472	472	
5,600pF	562	562	562	562	562	562	562	562	562	562	562	562	562	562	562	562	562	562	562	562	562	562	562	562	
6,800pF	682	682	682	682	682	682	682	682	682	682	682	682	682	682	682	682	682	682	682	682	682	682	682	682	
8,200pF	822	822	822	822	822	822	822	822	822	822	822	822	822	822	822	822	822	822	822	822	822	822	822	822	
0.01µF	103	103	103	103	103	103	103	103	103	103	103	103	103	103	103	103	103	103	103	103	103	103	103	103	
0.012µF	123	123	123	123	123		123	123	123	123	123	123	123	123	123	123	123	123	123	123	123	123	123	123	
0.015µF	153	153	153	153	153		153	153	153	153	153	153	153	153	153	153	153	153	153	153	153	153	153	153	
0.018µF	183	183	183	183			183	183	183	183	183	183	183	183	183	183	183	183	183	183	183	183	183	183	
0.022µF	223	223	223	223			223	223	223	223	223	223	223	223	223	223	223	223	223	223	223	223	223	223	
0.027µF	273	273	273	273			273	273	273	273	273	273	273	273	273	273	273	273	273	273	273	273	273	273	
0.033µF	333	333	333	333			333	333	333	333	333	333	333	333	333	333	333	333	333	333	333	333	333	333	
0.039µF	393	393	393	393			393	393	393	393	393	393	393	393	393	393	393	393	393	393	393	393	393	393	
0.047µF	473	473	473	473			473	473	473	473	473	473	473	473	473	473	473	473	473	473	473	473	473	473	
0.056µF	563	563	563				563	563	563	563	563	563	563	563	563	563	563	563	563	563	563	563	563	563	
0.068µF	683	683	683				683	683	683	683	683	683	683	683	683	683	683	683	683	683	683	683	683	683	
0.082µF	823	823	823				823	823	823	823	823	823	823	823	823	823	823	823	823	823	823	823	823	823	
0.1µF	104	104	104				104	104	104	104	104	104	104	104	104	104	104	104	104	104	104	104	104	104	
0.12µF	124	124	124				124	124	124				124					124							
0.15µF	154	154					154	154	154				154					154							
0.18µF	184	184					184	184	184				184					184							
0.22µF	224	224					224	224					224					224							
0.27µF	274	274					274	274					274					274							
0.33µF	334	334					334	334					334					334							
0.39µF	394	394					394	394					394					394							
0.47µF	474	474					474	474					474					474							
0.56µF	564						564	564					564					564							
0.68µF	684						684	684					684					684							
0.82µF	824						824	824					824					824							

Table 1B – SM25 - SM31 Style/Size con't

Style/Size	SM25					SM26					SM30					SM31									
Dimensions - In. (mm)																									
Length	0.550 ± 0.030 (14.00 ± 0.76)					0.650 ± 0.030 (16.50 ± 0.76)					0.300 ± 0.030 (7.62 ± 0.76)					0.400 ± 0.030 (10.20 ± 0.76)									
Width	0.500 ± 0.030 (12.70 ± 0.76)					0.600 ± 0.030 (15.20 ± 0.76)					0.150 ± 0.015 (3.81 ± 0.38)					0.200 ± 0.020 (5.08 ± 0.51)									
Thickness Max.	0.220 (5.59)					0.220 (5.59)					0.140 (3.55)					0.130 (3.30)									
Lead Width Max.	0.400 (10.20)					0.500 (12.70)					0.100 (2.54)					0.100 (2.54)									
Lead Length "L"	0.100 ± 0.020 (2.54 ± 0.51)					0.100 ± 0.020 (2.54 ± 0.51)					0.100 ± 0.020 (2.54 ± 0.51)					0.100 ± 0.020 (2.54 ± 0.51)									
Lead Length "J"	0.100 ± 0.020 (2.54 ± 0.51)					0.100 ± 0.020 (2.54 ± 0.51)					0.100 ± 0.020 (2.54 ± 0.51)					0.100 ± 0.020 (2.54 ± 0.51)									
X7R Dielectric																									
Voltage Code	501	102	202	302	402	502	501	102	202	302	402	502	501	102	202	302	402	501	102	202	302	402	502	Cap Tol	
Voltage DC	500	1K	2K	3K	4K	5K	500	1K	2K	3K	4K	5K	500	1K	2K	3K	4K	500	1K	2K	3K	4K	5K		
Capacitance	Capacitance Code																								
1.0µF	105						105	105																K, M, P, Z	
1.2µF	125						125																		
1.5µF	155						155																		
1.8µF	185						185																		
2.2µF							225																		
2.7µF							275																		
2.9µF							295																		

Table 1C – SM33 - SM35 Style/Size

Style/Size	SM33							SM34							SM35							Cap Tol		
Dimensions - In. (mm)																								
Length	0.700 ± 0.030 (17.08 ± 0.76)							0.900 ± 0.030 (22.90 ± 0.76)							1.100 ± 0.030 (27.90 ± 0.76)									
Width	0.300 ± 0.030 (7.62 ± 0.76)							0.400 ± 0.030 (10.20 ± 0.76)							0.500 ± 0.030 (12.70 ± 0.76)									
Thickness Max.	0.180 (4.57)							0.220 (5.59)							0.220 (5.59)									
Lead Width Max.	0.200 (5.08)							0.300 (7.62)							0.400 (10.2)									
Lead Length "L"	0.100 ± 0.020 (2.54 ± 0.51)							0.100 ± 0.020 (2.54 ± 0.51)							0.100 ± 0.020 (2.54 ± 0.51)									
Lead Length "J"	0.100 ± 0.020 (2.54 ± 0.51)							0.100 ± 0.020 (2.54 ± 0.51)							0.100 ± 0.020 (2.54 ± 0.51)									
X7R Dielectric																								
Voltage Code	501	102	202	302	402	502	752	501	102	202	302	402	502	752	103	501	102	202	302	402	502	752	103	Cap Tol
Voltage DC	500	1K	2K	3K	4K	5K	7.5K	500	1K	2K	3K	4K	5K	7.5K	10K	500	1K	2K	3K	4K	5K	7.5K	10K	
Capacitance	Capacitance Code																							
820pF	821	821	821	821	821	821	821	102	102	102	102	102	102	102	102								102	
1,000pF	102	102	102	102	102	102	102	122	122	122	122	122	122	122	122								122	
1,200pF	122	122	122	122	122	122	122	152	152	152	152	152	152	152	152								152	
1,500pF	152	152	152	152	152	152	152	182	182	182	182	182	182	182	182								182	
1,800pF	182	182	182	182	182	182	182	222	222	222	222	222	222	222	222								222	
2,200pF	222	222	222	222	222	222	222	272	272	272	272	272	272	272	272								272	
2,700pF	272	272	272	272	272	272	272	332	332	332	332	332	332	332	332								332	
3,300pF	332	332	332	332	332	332	332	392	392	392	392	392	392	392	392	332	332	332	332	332	332	332	332	
3,900pF	392	392	392	392	392	392	392	472	472	472	472	472	472	472	472	392	392	392	392	392	392	392	392	
4,700pF	472	472	472	472	472	472	472	562	562	562	562	562	562	562	562	472	472	472	472	472	472	472	472	
5,600pF	562	562	562	562	562	562		682	682	682	682	682	682	682	682	562	562	562	562	562	562	562	562	
6,800pF	682	682	682	682	682	682		822	822	822	822	822	822	822		682	682	682	682	682	682	682	682	
8,200pF	822	822	822	822	822			103	103	103	103	103	103	103		822	822	822	822	822	822	822		
0.01µF	103	103	103	103	103			123	123	123	123	123	123			103	103	103	103	103	103	103	103	
0.012µF	123	123	123	123	123			153	153	153	153	153	153			123	123	123	123	123	123			
0.015µF	153	153	153	153				183	183	183	183	183	183			153	153	153	153	153	153			
0.018µF	183	183	183	183				223	223	223	223	223	223			183	183	183	183	183	183			
0.022µF	223	223	223	223				273	273	273	273	273	273	223		223	223	223	223	223	223			
0.027µF	273	273	273	273				333	333	333	333	333				273	273	273	273	273	273			
0.033µF	333	333	333	333				393	393	393	393	393				333	333	333	333	333				
0.039µF	393	393	393	393				473	473	473	473					393	393	393	393	393				
0.047µF	473	473	473					563	563	563	563					473	473	473	473	473				
0.056µF	563	563	563					683	683	683	683					563	563	563	563					
0.068µF	683	683	683					823	823	823	823					683	683	683	683					
0.082µF	823	823	823					104	104	104						823	823	823	823					
0.1µF	104	104						124	124	124						104	104	104	104					
0.12µF	124	124						154	154	154						124	124	124						
0.15µF	154	154						184	184	184						154	154	154						
0.18µF	184	184						224	224	224						184	184	184						
0.22µF	224	224						274	274	274						224	224	224						
0.27µF	274	274						334	334							274	274	274						
0.33µF	334	334						394	394							334	334							
0.39µF	394	394						474	474							394	394							
0.47µF	474	474						564	564							474	474							
0.56µF	564	564						684	684							564	564							
0.68µF	684	684						824	824							684	684							
0.82µF	824							105	105							824	824							
1.0µF	105							125								105	105							
1.2µF	125							155								125	125							
1.5µF	155							185								155								
1.8µF								225								185								
2.2µF																225								
2.7µF																275								
2.9µF																295								
3.3µF																335								
3.9µF																395								

K, M, P, Z

Table 1D – SM36 Style/Size

Style/Size	SM36								Cap Tol
Dimensions - In. (mm)									
Length	1.350 ± 0.030 (33.00 ± 0.76)								
Width	0.600 ± 0.030 (15.20 ± 0.76)								
Thickness Max.	0.220 (5.59)								
Lead Width Max.	0.500 (12.7)								
Lead Length "L"	0.100 ± 0.020 (2.54 ± 0.51)								
Lead Length "J"	0.100 ± 0.020 (2.54 ± 0.51)								
X7R Dielectric									
Voltage Code	501	102	202	302	402	502	752	103	Cap Tol
Voltage DC	500	1K	2K	3K	4K	5K	7.5K	10K	
Capacitance	Capacitance Code								K, M, P, Z
1,500pF								152	
1,800pF								182	
2,200pF								222	
2,700pF								272	
3,300pF								332	
3,900pF								392	
4,700pF	472	472	472	472	472	472	472	472	
5,600pF	562	562	562	562	562	562	562	562	
6,800pF	682	682	682	682	682	682	682	682	
8,200pF	822	822	822	822	822	822	822	822	
0.01µF	103	103	103	103	103	103	103	103	
0.012µF	123	123	123	123	123	123	123		
0.015µF	153	153	153	153	153	153	153		
0.018µF	183	183	183	183	183	183	183		
0.022µF	223	223	223	223	223	223	223		
0.027µF	273	273	273	273	273	273			
0.033µF	333	333	333	333	333	333			
0.039µF	393	393	393	393	393	393			
0.047µF	473	473	473	473	473				
0.056µF	563	563	563	563	563				
0.068µF	683	683	683	683	683				
0.082µF	823	823	823	823					
0.1µF	104	104	104	104					
0.12µF	124	124	124	124					
0.15µF	154	154	154	154					
0.18µF	184	184	184						
0.22µF	224	224	224						
0.27µF	274	274	274						
0.33µF	334	334	334						
0.39µF	394	394							
0.47µF	474	474							
0.56µF	564	564							
0.68µF	684	684							
0.82µF	824	824							
1.0µF	105	105							
1.2µF	125	125							
1.5µF	155	155							
1.8µF	185	185							
2.2µF	225	225							
2.7µF	275								
2.9µF	295								
3.3µF	335								
3.9µF	395								
4.7µF	475								
5.6µF	565								

Table 2 – Chip Thickness / Packaging Quantities

Series	Style/Size	Tray Quantity Min. ¹	Tray Quantity Max. ¹
SM	SM20	1	50
	SM21		
	SM22		
	SM23		
	SM24		
	SM25		
	SM26		
	SM30		
	SM31		
	SM33		25
	SM34		10
	SM35		
	SM36		

¹ Minimum order value applies. Contact KEMET for details.

Soldering Process

The capacitors and assemblies outlined in this specification sheet are susceptible to thermal shock damage due to their large ceramic mass. Temperature profiles used should provide adequate temperature rise and cool-down time to prevent damage from thermal shock. In general, KEMET recommends against hand soldering for these types of large ceramic devices.

Recommended Soldering Technique:

- Solder reflow only

Preheating and Reflow Profile Notes:

Due to differences in the coefficient of thermal expansion for the different materials of construction, it is critical to monitor and control the heating and cooling rates during the soldering process. During the reflow soldering process, the maximum recommended heating and cooling rate (dT/dt) is 4°C/second. To ensure optimal component reliability, KEMET's recommended heating and cooling rate is 2°C/second. After soldering, the capacitors should be air cooled to room temperature before further processing. Forced air cooling is not recommended.

Recommended Reflow Soldering Profile:

Profile Feature	SnPb Assembly
Preheat/Soak	
Temperature Min (T_{smin})	100°C
Temperature Max (T_{smax})	150°C
Time (t_s) from T_{smin} to T_{smax}	60-90 sec
Ramp-up Rate (T_L to T_p)	2°C/sec
Liquidous Temperature (T_L)	183°C
Time Above Liquidous (t_L)	95 sec
Peak Temperature (T_p)	240°C
Time within 5°C of Max Peak Temperature (t_p)	5 sec
Ramp-down Rate (T_p to T_L)	2°C/sec
Time 25°C to Peak Temperature	3.5 minutes

Note 1: All temperatures refer to the center of the package, measured on the package body surface that is facing up during assembly reflow.

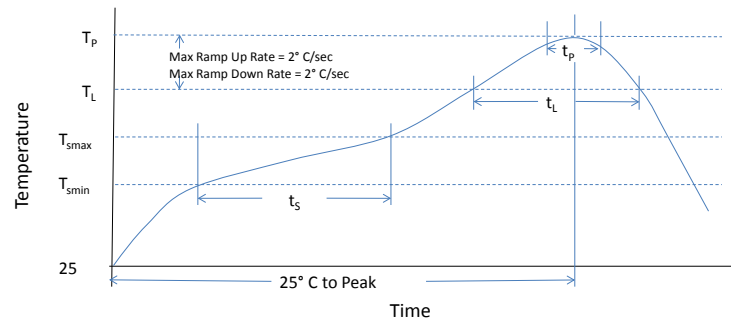

Construction

Reference	Item	Material
A	Leadframe	Phosphor Bronze - Alloy 510 (Silver plated / Nickle Underplate)
B	Leadframe Attach Material	Silver Epoxy
C	MLCC Termination System	Solderable Silver
D		
E		
F	Electrode	PdAg
G	Dielectric	BaTiO ₃

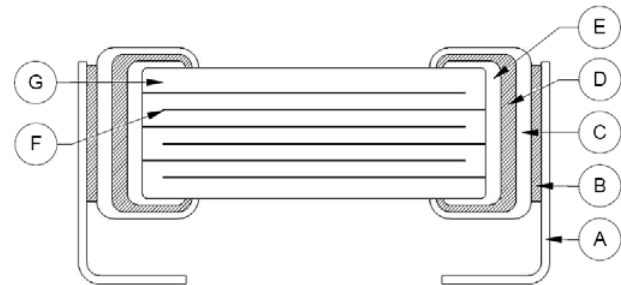

Note: Image is exaggerated in order to clearly identify all components of construction

Product Marking

Product marking is an extra-cost option. These devices will be supplied unmarked unless otherwise specified and/or requested. For more detailed information regarding marked product and how to request this option, please contact KEMET.

Table 3 – Performance & Reliability: Test Methods and Conditions

Stress	Reference	Test or Inspection Method
Board Flex	JIS-C-6429	Appendix 2, Note: 2 mm (min) for all except 3 mm for C0G.
Solderability	J-STD-002	Magnification 50 X. Conditions:
		a) Method B, 4 hours @ 155°C, dry heat @ 235°C
		b) Method B @ 215°C category 3
		c) Method D, category 3 @ 260°C
		1000 cycles (-55°C to +125°C). Measurement at 24 hours +/- 2 hours after test conclusion.
Biased Humidity	MIL-STD-202 Method 103	Load Humidity: 1000 hours 85°C/85%RH and 300VDC Max. Add 100K ohm resistor. Measurement at 24 hrs. +/- 2 hrs after test conclusion.
		Low Volt Humidity: 1000 hours 85°C/85%RH and 1.5V. Add 100K ohm resistor. Measurement at 24 hrs. +/- 2 hrs after test conclusion.
		t = 24 hours/cycle. Steps 7a & 7b not required. Unpowered. Measurement at 24 hours. +/- 2 hours after test conclusion.
Thermal Shock	MIL-STD-202 Method 107	-55°C/+125°C. Note: Number of cycles required – 300. Maximum transfer time – 20 seconds. D14 dwell time – 15 minutes. Air-Air.
High Temperature Life	MIL-STD-202 Method 108 / EIA -198	1000 hours at 125°C (85°C for X5R, Z5U and Y5V) with rated voltage applied.
Storage Life	MIL-STD-202 Method 108	150°C, 0VDC, for 1000 hours.
Vibration	MIL-STD-202 Method 204	5 g for 20 min., 12 cycles each of 3 orientations. Note: Use 8"X5" PCB .031" thick 7 secure points on one long side and 2 secure points at corners of opposite sides. Parts mounted within 2" from any secure point. Test from 10–2000 Hz.
Resistance to Soldering Heat	MIL-STD-202 Method 210	Condition B. No preheat of samples. Note: single wave solder – procedure 2.
Terminal Strength	MIL-STD-202 Method 211	Conditions A (2.3kg or 5lbs).
Mechanical Shock	MIL-STD-202 Method 213	Figure 1 of Method 213, Condition F.
Resistance to Solvents	MIL-STD-202 Method 215	Add aqueous wash chemical – OKEM Clean or equivalent.

Storage and Handling

Ceramic chip capacitors should be stored in normal working environments. While the chips themselves are quite robust in other environments, solderability will be degraded by exposure to high temperatures, high humidity, corrosive atmospheres, and long term storage. In addition, packaging materials will be degraded by high temperature – reels may soften or warp, and tape peel force may increase. KEMET recommends that maximum storage temperature not exceed 40°C, and maximum storage humidity not exceed 70% relative humidity. In addition, temperature fluctuations should be minimized to avoid condensation on the parts, and atmospheres should be free of chlorine and sulfur bearing compounds. For optimized solderability, chip stock should be used promptly, preferably within 1.5 years of receipt.

Application Notes

X7R dielectric is not recommended for AC line filtering or pulse applications.

Table 2 – Chip Thickness/Packaging Quantities

Thickness Code	Chip Size	Thickness ± Range (mm)	QTY per Reel 7" Plastic	QTY per Reel 13" Plastic	QTY per Reel 7" Paper	QTY per Reel 13" Paper	QTY per Bulk Cassette
AA	1005	0.20 ± 0.02			15000		
AB	0201	0.30 ± 0.03			15000		
BB	0402	0.50 ± 0.05			10000	50000	50000
BC	0402	0.50 ± 0.10			10000	50000	50000
PA	0508	0.80 ± 0.10	4000	10000			
CB	0603	0.80 ± 0.07			4000	10000	15000
CC	0603	0.80 ± 0.10			4000	10000	15000
CD	0603	0.80 ± 0.15			4000	10000	15000
MA	0612	0.80 ± 0.10	4000	10000			
DB	0805	0.60 ± 0.10			4000	10000	15000
DC	0805	0.78 ± 0.10			4000	10000	15000
DD	0805	0.90 ± 0.10			4000	10000	15000
DL	0805	0.95 ± 0.10	4000	10000			
DE	0805	1.00 ± 0.10	2500	10000			
DF	0805	1.10 ± 0.10	2500	10000			
DG	0805	1.25 ± 0.15	2500	10000			
DH	0805	1.25 ± 0.20	2500	10000			
EB	1206	0.78 ± 0.10	4000	10000	4000	10000	
EK	1206	0.80 ± 0.10	2000	8000			
EC	1206	0.90 ± 0.10	4000	10000			
EN	1206	0.95 ± 0.10	4000	10000			
ED	1206	1.00 ± 0.10	2500	10000			
EE	1206	1.10 ± 0.10	2500	10000			
EF	1206	1.20 ± 0.15	2500	10000			
EM	1206	1.25 ± 0.15	2500	10000			
EG	1206	1.60 ± 0.15	2000	8000			
EH	1206	1.60 ± 0.20	2000	8000			
EJ	1206	1.70 ± 0.20	2000	8000			
FB	1210	0.78 ± 0.10	4000	10000			
FC	1210	0.90 ± 0.10	4000	10000			
FD	1210	0.95 ± 0.10	4000	10000			
FE	1210	1.00 ± 0.10	2500	10000			
FF	1210	1.10 ± 0.10	2500	10000			
FG	1210	1.25 ± 0.15	2500	10000			
FL	1210	1.40 ± 0.15	2000	8000			
FO	1210	1.50 ± 0.20	2000	8000			
FH	1210	1.55 ± 0.15	2000	8000			
FP	1210	1.60 ± 0.20	2000	8000			
FM	1210	1.70 ± 0.20	2000	8000			
FJ	1210	1.85 ± 0.20	2000	8000			
FN	1210	1.85 ± 0.20	2000	8000			
FT	1210	1.90 ± 0.20	1500	4000			
FK	1210	2.10 ± 0.20	2000	8000			
FR	1210	2.25 ± 0.20	2000	8000			
FS	1210	2.50 ± 0.20	1000	4000			
FV	1210	3.35 ± 0.10	500	1800			
FW	1210	6.15 ± 0.15	200	1000			
PA	1220	0.80 ± 0.10	4000	10000			
MA	1632	0.80 ± 0.10	4000	10000			
NA	1706	0.90 ± 0.10	4000	10000			
NB	1706	1.00 ± 0.10	4000	10000			
NC	1706	1.00 ± 0.15	4000	10000			
LD	1808	0.90 ± 0.10	2500	10000			
LE	1808	1.00 ± 0.10	2500	10000			
LF	1808	1.00 ± 0.15	2500	10000			
LA	1808	1.40 ± 0.15	1000	4000			
LB	1808	1.60 ± 0.15	1000	4000			
LC	1808	2.00 ± 0.15	1000	4000			
GB	1812	1.00 ± 0.10	1000	4000			
GC	1812	1.10 ± 0.10	1000	4000			
GD	1812	1.25 ± 0.15	1000	4000			
GE	1812	1.30 ± 0.10	1000	4000			
GH	1812	1.40 ± 0.15	1000	4000			
GF	1812	1.50 ± 0.10	1000	4000			
GG	1812	1.55 ± 0.10	1000	4000			
GK	1812	1.60 ± 0.20	1000	4000			
GJ	1812	1.70 ± 0.15	1000	4000			
GN	1812	1.70 ± 0.20	1000	4000			
GL	1812	1.90 ± 0.20	1000	4000			
GM	1812	2.00 ± 0.20	1000	4000			
GO	1812	2.50 ± 0.20	500	2000			
GP	1812	2.65 ± 0.35	500	1400			
GR	1812	5.00 ± 0.50	350	1000			
HB	1825	1.10 ± 0.15	1000	4000			
HC	1825	1.15 ± 0.15	1000	4000			
HD	1825	1.30 ± 0.15	1000	4000			
HE	1825	1.40 ± 0.15	1000	4000			
HF	1825	1.50 ± 0.15	1000	4000			
Thickness Code	Chip Size	Thickness ± Range (mm)	QTY per Reel 7" Plastic	QTY per Reel 13" Plastic	QTY per Reel 7" Paper	QTY per Reel 13" Paper	QTY per Bulk Cassette

Package Quantity
 Based on Finished Chip
 Thickness Specifications

Table 2 – Chip Thickness/Packaging Quantities con't

Thickness Code	Chip Size	Thickness ± Range (mm)	QTY per Reel 7" Plastic	QTY per Reel 13" Plastic	QTY per Reel 7" Paper	QTY per Reel 13" Paper	QTY per Bulk Cassette
HG	1825	1.60 ± 0.20	1000	4000			
JB	2220	1.00 ± 0.15	1000	4000			
JC	2220	1.10 ± 0.15	1000	4000			
JD	2220	1.30 ± 0.15	1000	4000			
JE	2220	1.40 ± 0.15	1000	4000			
JF	2220	1.50 ± 0.15	1000	4000			
JP	2220	1.60 ± 0.20	1000	4000			
JG	2220	1.70 ± 0.15	1000	4000			
JH	2220	1.80 ± 0.15	1000	4000			
JO	2220	2.40 ± 0.15	500	2000			
JP	2220	3.50 ± 0.30	250	850			
JR	2220	5.00 ± 0.50	150	600			
KB	2225	1.00 ± 0.15	1000	4000			
KC	2225	1.10 ± 0.15	1000	4000			
KD	2225	1.30 ± 0.15	1000	4000			
KE	2225	1.40 ± 0.15	1000	4000			
KF	2225	1.60 ± 0.20	1000	4000			
Thickness Code	Chip Size	Thickness ± Range (mm)	QTY per Reel 7" Plastic	QTY per Reel 13" Plastic	QTY per Reel 7" Paper	QTY per Reel 13" Paper	QTY per Bulk Cassette

Table 3 – Chip Capacitor Land Pattern Design Recommendations per IPC-7351

EIA Size Code	Metric Size Code	Density Level A: Maximum (Most) Land Protrusion (mm)					Density Level B: Median (Nominal) Land Protrusion (mm)					Density Level C: Minimum (Least) Land Protrusion (mm)				
		C	Y	X	V1	V2	C	Y	X	V1	V2	C	Y	X	V1	V2
01005	0402	0.33	0.46	0.43	1.60	0.90	0.28	0.36	0.33	1.30	0.70	0.23	0.26	0.23	1.00	0.50
0201	0603	0.38	0.56	0.52	1.80	1.00	0.33	0.46	0.42	1.50	0.80	0.28	0.36	0.32	1.20	0.60
0402	1005	0.50	0.72	0.72	2.20	1.20	0.45	0.62	0.62	1.90	1.00	0.40	0.52	0.52	1.60	0.80
0603	1608	0.90	1.15	1.10	4.00	2.10	0.80	0.95	1.00	3.10	1.50	0.60	0.75	0.90	2.40	1.20
0805	2012	1.00	1.35	1.55	4.40	2.60	0.90	1.15	1.45	3.50	2.00	0.75	0.95	1.35	2.80	1.70
1206	3216	1.60	1.35	1.90	5.60	2.90	1.50	1.15	1.80	4.70	2.30	1.40	0.95	1.70	4.00	2.00
1210	3225	1.60	1.35	2.80	5.65	3.80	1.50	1.15	2.70	4.70	3.20	1.40	0.95	2.60	4.00	2.90
1808	4520	2.30	1.75	2.30	7.40	3.30	2.20	1.55	2.20	6.50	2.70	2.10	1.35	2.10	5.80	2.40
1812	4532	2.15	1.60	3.60	6.90	4.60	2.05	1.40	3.50	6.00	4.00	1.95	1.20	3.40	5.30	3.70
1825	4564	2.15	1.60	6.90	6.90	7.90	2.05	1.40	6.80	6.00	7.30	1.95	1.20	6.70	5.30	7.00
2220	5650	2.75	1.70	5.50	8.20	6.50	2.65	1.50	5.40	7.30	5.90	2.55	1.30	5.30	6.60	5.60
2225	5664	2.70	1.70	6.90	8.10	7.90	2.60	1.50	6.80	7.20	7.30	2.50	1.30	6.70	6.50	7.00

Density Level A: For low-density Product applications. Recommended for wave solder applications and provides a wider process window for reflow solder processes. KEMET only recommends wave soldering of EIA 0603, 0805 and 1206 case sizes.

Density Level B: For products with a moderate level of component density. Provides a robust solder attachment condition for reflow solder processes.

Density Level C: For high component density product applications. Before adapting the minimum land pattern variations the user should perform qualification testing based on the conditions outlined in IPC standard 7351 (IPC-7351).

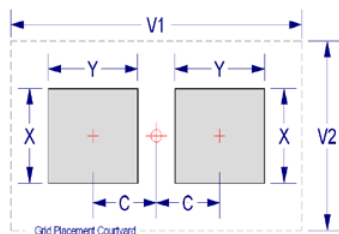

Soldering Process

Recommended Soldering Technique:

- Solder wave or solder reflow for EIA case sizes 0603, 0805 and 1206
- All other EIA case sizes are limited to solder reflow only

Recommended Soldering Profile:

- KEMET recommends following the guidelines outlined in IPC/JEDEC J-STD-020

Table 4 – Performance & Reliability: Test Methods and Conditions

Stress	Reference	Test or Inspection Method
Terminal Strength	JIS-C-6429	Appendix 1, Note: Force of 1.8kg for 60 seconds.
Board Flex	JIS-C-6429	Appendix 2, Note: 2mm (min) for all except 3mm for C0G.
Solderability	J-STD-002	Magnification 50 X. Conditions:
		a) Method B, 4 hours @ 155°C, dry heat @ 235°C
		b) Method B @ 215°C category 3
		c) Method D, category 3 @ 260°C
Temperature Cycling	JESD22 Method JA-104	1000 cycles (-55°C to +125°C), Measurement at 24 hours. +/- 2 hours after test conclusion.
Biased Humidity	MIL-STD-202 Method 103	Load Humidity: 1000 hours 85°C/85%RH and Rated Voltage. Add 100K ohm resistor. Measurement at 24 hours. +/- 2 hours after test conclusion.
		Low Volt Humidity: 1000 hours 85°C/85%RH and 1.5V. Add 100K ohm resistor. Measurement at 24 hours. +/- 2 hours after test conclusion.
Moisture Resistance	MIL-STD-202 Method 106	t = 24 hours/cycle. Steps 7a & 7b not required. Unpowered. Measurement at 24 hours. +/- 2 hours after test conclusion.
Thermal Shock	MIL-STD-202 Method 107	-55°C/+125°C. Note: Number of cycles required-300, maximum transfer time-20 seconds, dwell time-15 minutes. Air-Air.
High Temperature Life	MIL-STD-202 Method 108 / EIA -198	1000 hours at 125°C (85°C for X5R, Z5U and Y5V) with 2 X rated voltage applied.
Storage Life	MIL-STD-202 Method 108	150°C, 0VDC, for 1000 hours.
Mechanical Shock	MIL-STD-202 Method 213	Figure 1 of Method 213, Condition F.
Resistance to Solvents	MIL-STD-202 Method 215	Add aqueous wash chemical - OKEM Clean or equivalent.

Storage and Handling

Ceramic chip capacitors should be stored in normal working environments. While the chips themselves are quite robust in other environments, solderability will be degraded by exposure to high temperatures, high humidity, corrosive atmospheres, and long term storage. In addition, packaging materials will be degraded by high temperature – reels may soften or warp, and tape peel force may increase. KEMET recommends that maximum storage temperature not exceed 40°C, and maximum storage humidity not exceed 70% relative humidity. In addition, temperature fluctuations should be minimized to avoid condensation on the parts, and atmospheres should be free of chlorine and sulfur bearing compounds. For optimized solderability, chip stock should be used promptly, preferably within 1.5 years of receipt.

Tape & Reel Packaging Information

KEMET offers Multilayer Ceramic Chip Capacitors packaged in 8mm, 12mm and 16mm tape on 7" and 13" reels in accordance with EIA standard 481. This packaging system is compatible with all tape fed automatic pick and place systems. See Table 2 for details on reeling quantities for commercial chips.

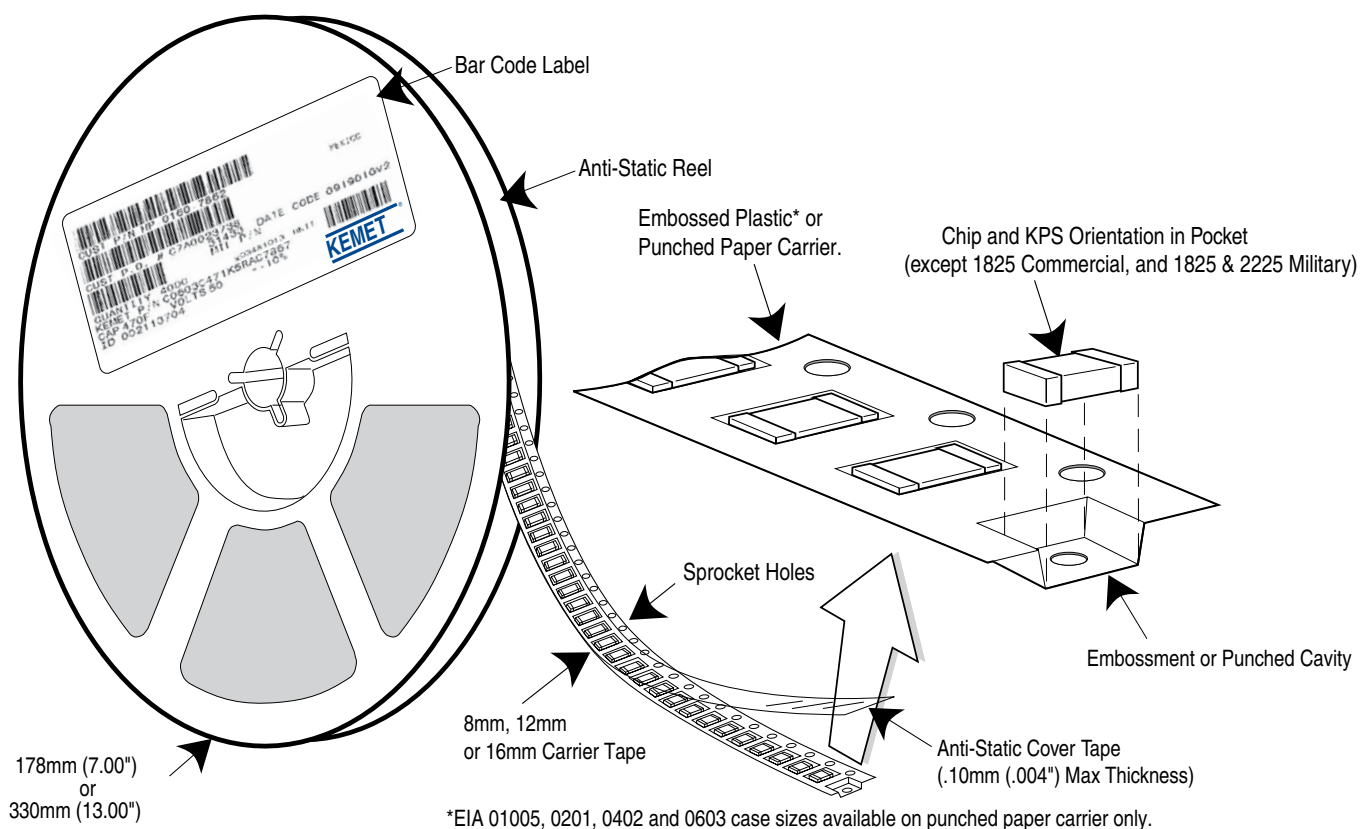

Table 5 – Carrier Tape Configuration (mm)

EIA Case Size	Tape Size (W)*	Lead Space (P ₁)*
01005 - 0402	8	2
0603 - 1210	8	4
1805 - 1808	12	4
≥ 1812	12	8
KPS 1210	12	8
KPS 1812 & 2220	16	12
Array 0508 & 0612	8	4

*Refer to Figure 1 for W and P₁ carrier tape reference locations.

*Refer to Table 6 for tolerance specifications.

Figure 1 – Embossed (Plastic) Carrier Tape Dimensions

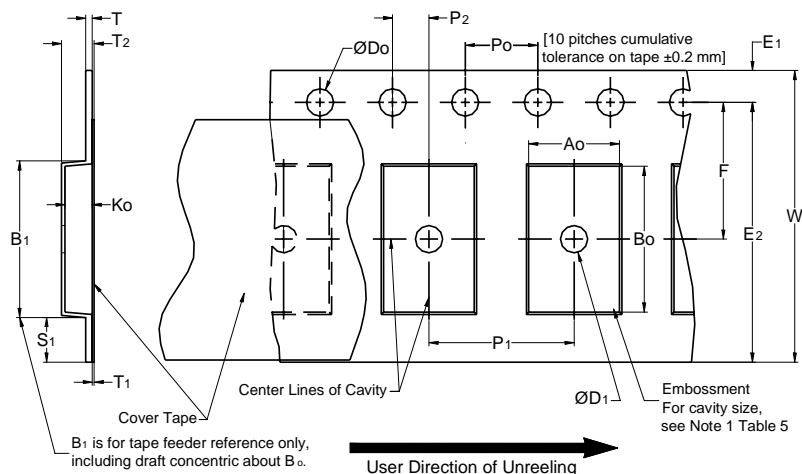

Table 6 – Embossed (Plastic) Carrier Tape Dimensions

Metric will govern

Constant Dimensions — Millimeters (Inches)									
Tape Size	D_0	D_1 Min. Note 1	E_1	P_0	P_2	R Ref. Note 2	S_1 Min. Note 3	T Max.	T_1 Max.
8mm	$1.5 +0.10/-0.0$ ($0.059 +0.004/-0.0$)	1.0 (0.039)	1.75 ± 0.10 (0.069 ± 0.004)	4.0 ± 0.10 (0.157 ± 0.004)	2.0 ± 0.05 (0.079 ± 0.002)	25.0 (0.984)	0.600 (0.024)	0.600 (0.024)	0.100 (0.004)
12mm		1.5 (0.059)				30 (1.181)			
16mm									
Variable Dimensions — Millimeters (Inches)									
Tape Size	Pitch	B_1 Max. Note 4	E_2 Min.	F	P_1	T_2 Max	W Max	A_0, B_0 & K_0	
8mm	Single (4mm)	4.35 (0.171)	6.25 (0.246)	3.5 ± 0.05 (0.138 ± 0.002)	4.0 ± 0.10 (0.157 ± 0.004)	2.5 (0.098)	8.3 (0.327)	Note 5	
12mm	Single (4mm) & Double (8mm)	8.2 (0.323)	10.25 (0.404)	5.5 ± 0.05 (0.217 ± 0.002)	8.0 ± 0.10 (0.315 ± 0.004)	4.6 (0.181)	12.3 (0.484)		
16mm	Triple (12mm)	12.1 (0.476)	14.25 (0.561)	5.5 ± 0.05 (0.217 ± 0.002)	8.0 ± 0.10 (0.315 ± 0.004)	4.6 (0.181)	16.3 (0.642)		

1. The embossment hole location shall be measured from the sprocket hole controlling the location of the embossment. Dimensions of embossment location and hole location shall be applied independent of each other.
2. The tape with or without components shall pass around R without damage (see Figure 5).
3. If $S_1 < 1.0$ mm, there may not be enough area for cover tape to be properly applied (see EIA Document 481 paragraph 4.3 (b)).
4. B_1 dimension is a reference dimension for tape feeder clearance only.
5. The cavity defined by A_0 , B_0 and K_0 shall surround the component with sufficient clearance that:
 - (a) the component does not protrude above the top surface of the carrier tape.
 - (b) the component can be removed from the cavity in a vertical direction without mechanical restriction, after the top cover tape has been removed.
 - (c) rotation of the component is limited to 20° maximum for 8 and 12mm tapes and 10° maximum for 16mm tapes (see Figure 3).
 - (d) lateral movement of the component is restricted to 0.5 mm maximum for 8mm and 12mm wide tape and to 1.0mm maximum for 16mm tape (see Figure 4).
 - (e) for KPS Series product A_0 and B_0 are measured on a plane 0.3mm above the bottom of the pocket.
 - (f) see Addendum in EIA Document 481 for standards relating to more precise taping requirements.

Figure 2 – Punched (Paper) Carrier Tape Dimensions

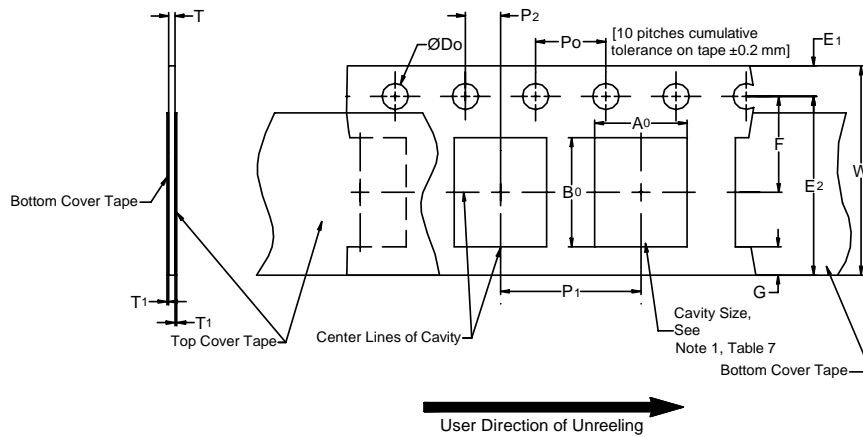

Table 7 – Punched (Paper) Carrier Tape Dimensions

Metric will govern

Constant Dimensions — Millimeters (Inches)							
Tape Size	D_0	E_1	P_0	P_2	T_1 Max	G Min	R Ref. Note 2
8mm	$1.5 +0.10-0.0$ (0.059 +0.004, -0.0)	1.75 ± 0.10 (0.069 ±0.004)	4.0 ± 0.10 (0.157 ±0.004)	2.0 ± 0.05 (0.079 ±0.002)	0.10 (.004) Max.	0.75 (.030)	25 (.984)
Variable Dimensions — Millimeters (Inches)							
Tape Size	Pitch	E_2 Min	F	P_1	T Max	W Max	$A_0 B_0$
8mm	Half (2mm)	6.25 (0.246)	3.5 ± 0.05 (0.138 ± 0.002)	2.0 ± 0.05 (0.079 ± 0.002)	1.1 (0.098)	8.3 (0.327)	Note 5
8mm	Single (4mm)			4.0 ± 0.10 (0.157 ± 0.004)		8.3 (0.327)	

- The cavity defined by A_0 , B_0 and T shall surround the component with sufficient clearance that:
 - the component does not protrude beyond either surface of the carrier tape.
 - the component can be removed from the cavity in a vertical direction without mechanical restriction, after the top cover tape has been removed.
 - lateral movement of the component is restricted to 0.5 mm maximum (see Figure 4).
 - see Addendum in EIA Document 481 for standards relating to more precise taping requirements.
- The tape with or without components shall pass around R without damage (see Figure 5).

Packaging Information Performance Notes

1. Cover Tape Break Force: 1.0 Kg Minimum.
2. Cover Tape Peel Strength: The total peel strength of the cover tape from the carrier tape shall be:

Tape Width	Peel Strength
8mm	0.1 Newton to 1.0 Newton (10gf to 100gf)
12mm & 16mm	0.1 Newton to 1.3 Newton (10gf to 130gf)

The direction of the pull shall be opposite the direction of the carrier tape travel. The pull angle of the carrier tape shall be 165° to 180° from the plane of the carrier tape. During peeling, the carrier and/or cover tape shall be pulled at a velocity of 300±10 mm/minute.

3. Labeling: Bar code labeling (standard or custom) shall be on the side of the reel opposite the sprocket holes. Refer to EIA-556 and EIA-624.

Figure 3 – Maximum Component Rotation

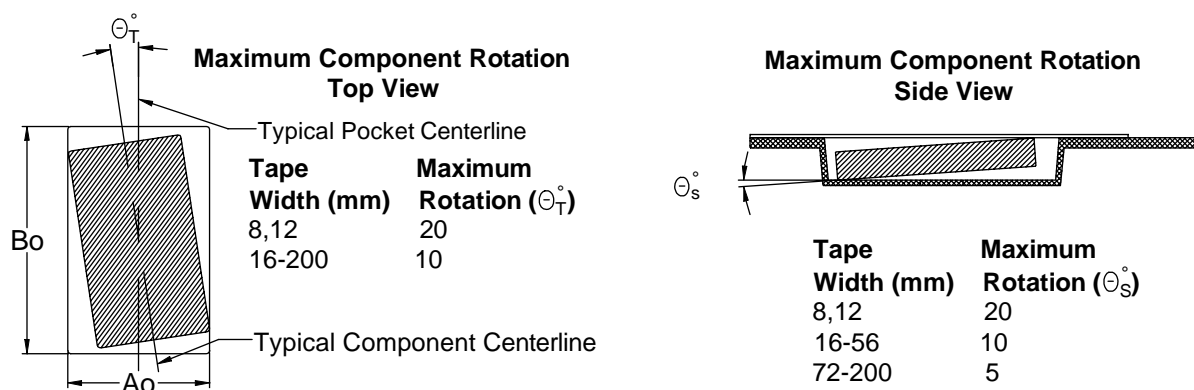

Figure 4 – Maximum Lateral Movement

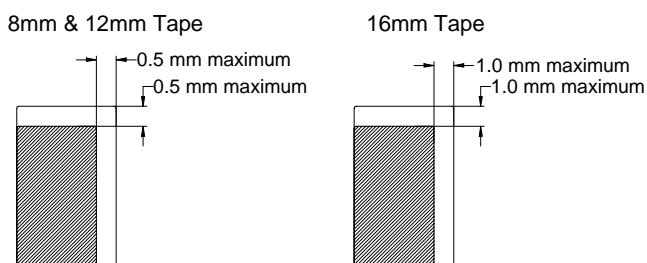

Figure 5 – Bending Radius

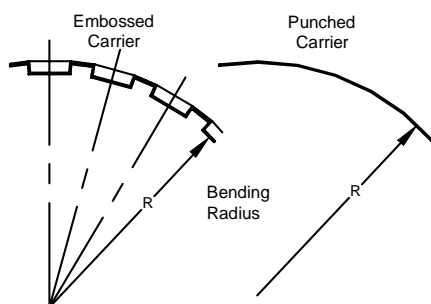
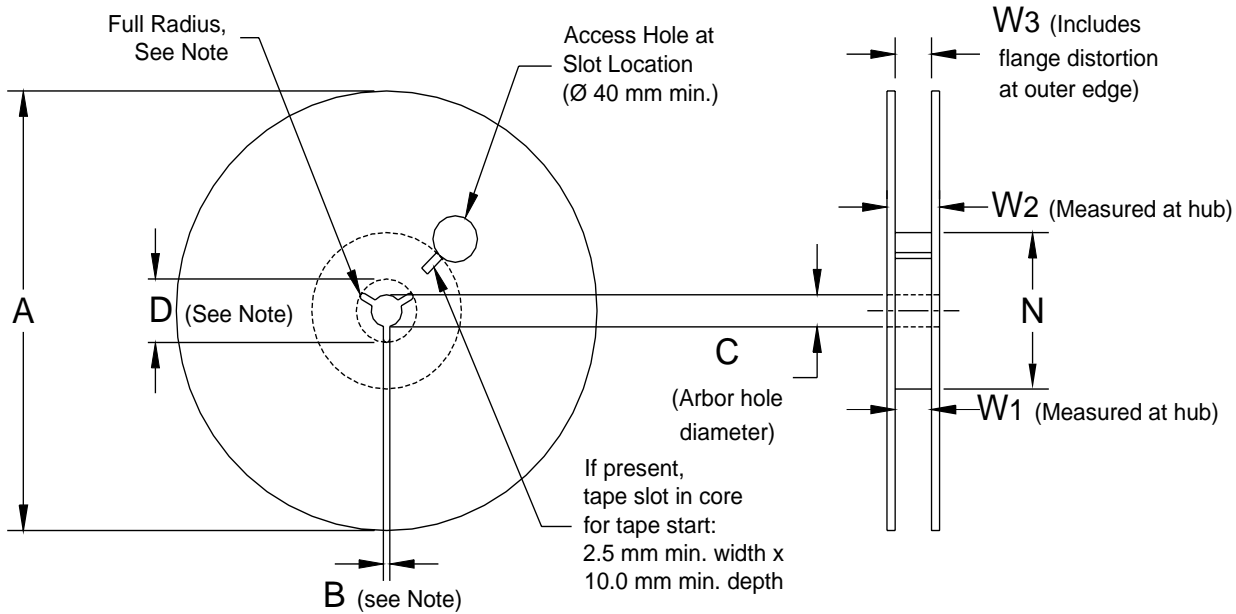

Figure 6 – Reel Dimensions



Note: Drive spokes optional; if used, dimensions B and D shall apply.

Table 8 – Reel Dimensions

Metric will govern

Constant Dimensions – Millimeters (Inches)				
Tape Size	A	B Min	C	D Min
8mm	178 ± 0.20 (7.008 ± 0.008)	1.5 (0.059)	13.0 +0.5/-0.2 (0.521 +0.02/-0.008)	20.2 (0.795)
12mm	or			
16mm	330 ± 0.20 (13.000 ± 0.008)			
Variable Dimensions – Millimeters (Inches)				
Tape Size	N Min	W ₁	W ₂ Max	W ₃
8mm	50 (1.969)	8.4 +1.5/-0.0 (0.331 +0.059/-0.0)	14.4 (0.567)	Shall accommodate tape width without interference
12mm		12.4 +2.0/-0.0 (0.488 +0.078/-0.0)	18.4 (0.724)	
16mm		16.4 +2.0/-0.0 (0.646 +0.078/-0.0)	22.4 (0.882)	

Figure 7 – Tape Leader & Trailer Dimensions

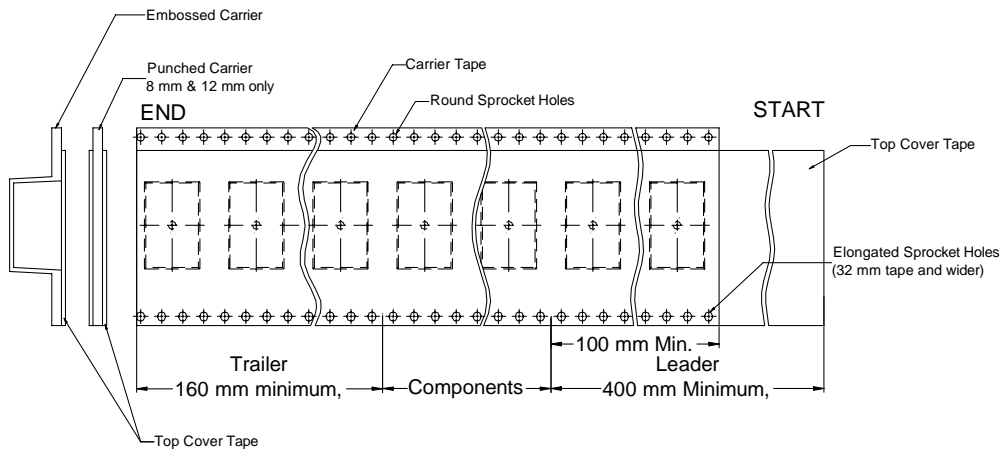

Figure 8 – Maximum Camber

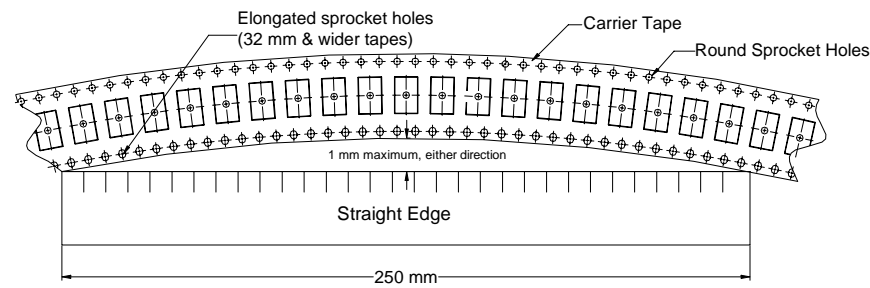

Figure 9 – Bulk Cassette Packaging (Ceramic Chips Only)

Meets Dimensional Requirements IEC-286 and EIAJ 7201

Unit mm *Reference

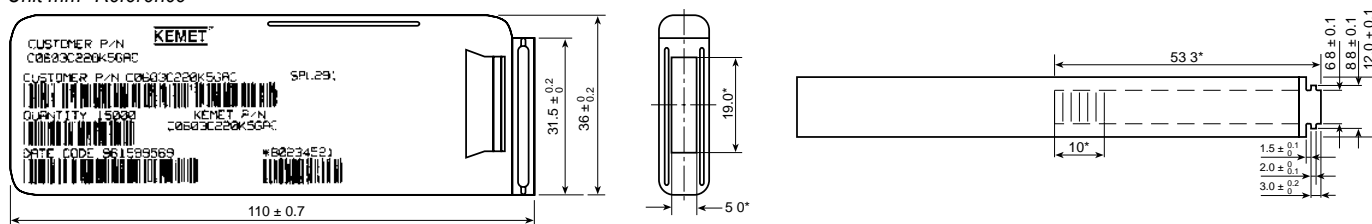

Table 9 – Capacitor Dimensions for Bulk Cassette

Cassette Packaging – Millimeters

EIA Size Code	Metric Size Code	L Length	W Width	B Bandwidth	S Separation minimum	T Thickness	Number of Pcs/Cassette
0402	1005	1.0 ± 0.05	0.5 ± 0.05	0.2 to 0.4	0.3	0.5 ± .05	50,000
0603	1608	1.6 ± 0.07	0.8 ± 0.07	0.2 to 0.5	0.7	0.8 ± .07	15,000

Table 10 – Capacitor Marking

Laser marking is available as an extra-cost option for most KEMET ceramic chips. Such marking is two sided, and includes a K to identify KEMET, followed by two characters (per EIA-198) to identify the capacitance value. Note that marking is not available for any Y5V chip. In addition, the 0603 marking option is limited to the K only. (Marking Optional – Not Available for 0402 Size)

Numeral Alpha Character	Capacitance (pF) For Various Numeral Identifiers									
	9	0	1	2	3	4	5	6	7	
A	0.1	1	10	100	1000	10000	100000	1000000	10000000	
B	0.11	1.1	11	110	1100	11000	110000	1100000	11000000	
C	0.12	1.2	12	120	1200	12000	120000	1200000	12000000	
D	0.13	1.3	13	130	1300	13000	130000	1300000	13000000	
E	0.15	1.5	15	150	1500	15000	150000	1500000	15000000	
F	0.16	1.6	16	160	1600	16000	160000	1600000	16000000	
G	0.18	1.8	18	180	1800	18000	180000	1800000	18000000	
H	0.2	2	20	200	2000	20000	200000	2000000	20000000	
J	0.22	2.2	22	220	2200	22000	220000	2200000	22000000	
K	0.24	2.4	24	240	2400	24000	240000	2400000	24000000	
L	0.27	2.7	27	270	2700	27000	270000	2700000	27000000	
M	0.3	3	30	300	3000	30000	300000	3000000	30000000	
N	0.33	3.3	33	330	3300	33000	330000	3300000	33000000	
P	0.36	3.6	36	360	3600	36000	360000	3600000	36000000	
Q	0.39	3.9	39	390	3900	39000	390000	3900000	39000000	
R	0.43	4.3	43	430	4300	43000	430000	4300000	43000000	
S	0.47	4.7	47	470	4700	47000	470000	4700000	47000000	
T	0.51	5.1	51	510	5100	51000	510000	5100000	51000000	
U	0.56	5.6	56	560	5600	56000	560000	5600000	56000000	
V	0.62	6.2	62	620	6200	62000	620000	6200000	62000000	
W	0.68	6.8	68	680	6800	68000	680000	6800000	68000000	
X	0.75	7.5	75	750	7500	75000	750000	7500000	75000000	
Y	0.82	8.2	82	820	8200	82000	820000	8200000	82000000	
Z	0.91	9.1	91	910	9100	91000	910000	9100000	91000000	
a	0.25	2.5	25	250	2500	25000	250000	2500000	25000000	
b	0.35	3.5	35	350	3500	35000	350000	3500000	35000000	
d	0.4	4	40	400	4000	40000	400000	4000000	40000000	
e	0.45	4.5	45	450	4500	45000	450000	4500000	45000000	
f	0.5	5	50	500	5000	50000	500000	5000000	50000000	
m	0.6	6	60	600	6000	60000	600000	6000000	60000000	
n	0.7	7	70	700	7000	70000	700000	7000000	70000000	
t	0.8	8	80	800	8000	80000	800000	8000000	80000000	
y	0.9	9	90	900	9000	90000	900000	9000000	90000000	

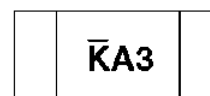

Example shown is 1,000 pF capacitor

KEMET Corporation World Headquarters

2835 KEMET Way
Simpsonville, SC 29681

Mailing Address:
P.O. Box 5928
Greenville, SC 29606

www.kemet.com
Tel: 864-963-6300
Fax: 864-963-6521

Corporate Offices

Fort Lauderdale, FL
Tel: 954-766-2800

North America

Southeast

Lake Mary, FL
Tel: 407-855-8886

Northeast

Wilmington, MA
Tel: 978-658-1663

West Chester, PA
Tel: 610-692-4642

Central

Schaumburg, IL
Tel: 847-882-3590

Carmel, IN
Tel: 317-706-6742

West

Milpitas, CA
Tel: 408-433-9950

Mexico

Zapopan, Jalisco
Tel: 52-33-3123-2141

Europe

Southern Europe

Geneva, Switzerland
Tel: 41-22-715-0100

Paris, France
Tel: 33-1-4646-1009

Sasso Marconi, Italy
Tel: 39-051-939111

Milan, Italy
Tel: 39-02-57518176

Rome, Italy
Tel: 39-06-23231718

Madrid, Spain
Tel: 34-91-804-4303

Central Europe

Landsberg, Germany
Tel: 49-8191-3350800

Dortmund, Germany
Tel: 49-2307-3619672

Kwidzyn, Poland
Tel: 48-55-279-7025

Northern Europe

Bishop's Stortford, United Kingdom
Tel: 44-1279-757201

Weymouth, United Kingdom
Tel: 44-1305-830747

Coatbridge, Scotland
Tel: 44-1236-434455

Färjestaden, Sweden
Tel: 46-485-563934

Espoo, Finland
Tel: 358-9-5406-5000

Asia

Northeast Asia

Hong Kong
Tel: 852-2305-1168

Shenzhen, China
Tel: 86-755-2518-1306

Beijing, China
Tel: 86-10-5829-1711

Shanghai, China
Tel: 86-21-6447-0707

Taipei, Taiwan
Tel: 886-2-27528585

Southeast Asia

Singapore
Tel: 65-6586-1900

Penang, Malaysia
Tel: 60-4-6430200

Bangalore, India
Tel: 91-806-53-76817

Note: KEMET reserves the right to modify minor details of internal and external construction at any time in the interest of product improvement. KEMET does not assume any responsibility for infringement that might result from the use of KEMET Capacitors in potential circuit designs. KEMET is a registered trademark of KEMET Electronics Corporation.

Other KEMET Resources

Tools	
Resource	Location
Configure A Part: CapEdge	http://capacitoredge.kemet.com
SPICE & FIT Software	http://www.kemet.com/spice
Search Our FAQs: KnowledgeEdge	http://www.kemet.com/keask

Product Information	
Resource	Location
Products	http://www.kemet.com/products
Technical Resources (Including Soldering Techniques)	http://www.kemet.com/technicalpapers
RoHS Statement	http://www.kemet.com/rohs
Quality Documents	http://www.kemet.com/qualitydocuments

Product Request	
Resource	Location
Sample Request	http://www.kemet.com/sample
Engineering Kit Request	http://www.kemet.com/kits

Contact	
Resource	Location
Website	www.kemet.com
Contact Us	http://www.kemet.com/contact
Investor Relations	http://www.kemet.com/ir
Call Us	1-877-MyKEMET
Twitter	http://twitter.com/kemetcapacitors

Disclaimer

All product specifications, statements, information and data (collectively, the "Information") are subject to change without notice.

All Information given herein is believed to be accurate and reliable, but is presented without guarantee, warranty, or responsibility of any kind, expressed or implied.

Statements of suitability for certain applications are based on our knowledge of typical operating conditions for such applications, but are not intended to constitute – and we specifically disclaim – any warranty concerning suitability for a specific customer application or use. This Information is intended for use only by customers who have the requisite experience and capability to determine the correct products for their application. Any technical advice inferred from this Information or otherwise provided by us with reference to the use of our products is given gratis, and we assume no obligation or liability for the advice given or results obtained.

Although we design and manufacture our products to the most stringent quality and safety standards, given the current state of the art, isolated component failures may still occur. Accordingly, customer applications which require a high degree of reliability or safety should employ suitable designs or other safeguards (such as installation of protective circuitry or redundancies) in order to ensure that the failure of an electrical component does not result in a risk of personal injury or property damage.

Although all product-related warnings, cautions and notes must be observed, the customer should not assume that all safety measures are indicated or that other measures may not be required.

Product & Process Design

Sales & Marketing

Supplier

Material Management

Quality

Manufacturing

Logistics & Distribution

People: Leadership
& Development

KEMET Production System

Corporate Offices

KEMET Corporation
2835 KEMET Way
Simpsonville, SC 29681
USA
Tel: 864.963.6300
Fax: 864.963.6521

KEMET Electronics S.A.
15bis chemin des Mines
1202 Geneva
Switzerland
Tel: 41.22.715.0100
Fax: 41.22.715.0170

KEMET Electronics Marketing (S) Pte Ltd.
73 Bukit Timah Road
#05-01 Rex House
Singapore 229832
Tel: 65.6586.1900
Fax: 65.6586.1901

www.kemet.com

The Capacitance Company
KEMET
CHARGED®