

【 3. 定格及び適用電線 RATINGS AND APPLICABLE WIRES】

項目 Item	規格 Standard		
最大許容電圧 Rated Voltage (MAX)	125 V (実効値 rms)		[AC(実効値 rms) / DC]
最大許容電流 及び適用電線 Rated Current (MAX) and Applicable wires	AWG #26	2.0 A	被覆外径 Insulation Diameter : 501338*00: ϕ 0.5~1.0mm 501258*00: ϕ 0.5~1.0mm 500588*00: ϕ 0.5~1.0mm 500798*00: ϕ 0.5~1.04mm
	AWG #28	1.5 A	
	AWG #30	1.0 A	
	AWG #32	1.0 A	
使用温度範囲*1 Ambient Temperature Range	-40°C ~ +105°C*2*3		

*1: 基板実装後の無通電状態は、使用温度範囲が適用されます。

Non-operating connectors after reflow must follow the operating temperature range condition.

*2: 通電による温度上昇分も含む。

Including terminal temperature rise.

*3: 適合電線も本使用温度範囲を満足すること。

Applicable wires must also meet the specified temperature range.

参考許容電流 CURRENT DERATING REFERENCE INFORMATION

AWG	2-circuits	6-circuits	10-circuits
	Amps (A)	Amps (A)	Amps (A)
26	2.5	2.0	2.0
28	2.0	1.5	1.5
30	1.5	1.0	1.0
32	1.3	1.0	1.0

1) 各電流値は参考となります。

Values are for REFERENCE ONLY

2) 閾値は温度上昇30°C以下としています。

Current deratings are based on not exceeding 30°C Temperature Rise.

3) 温度上昇の測定は圧着端子のバレル部にて実施しています。

Temperature Rise is measured in barrel area of crimp terminal.

4) 基板デザインにより温度上昇の結果が異なります。

PCB trace design can greatly affect temperature rise results.

5) 全極に通電し測定しています。

Data is for all circuits powered.

THIS DOCUMENT CONTAINS INFORMATION THAT IS PROPRIETARY TO MOLEX ELECTRONIC TECHNOLOGIES, LLC AND SHOULD NOT BE USED WITHOUT WRITTEN PERMISSION

REVISION DESCRIPTION	REVISED	PRODUCT SPECIFICATION FOR PICOBLADE 1.25 W/W TIN PLATING CONNECTOR					
CHANGE NO.	702978						
REVISED BY	QHE31	DATE	2022/03/11	DOC TYPE	DOC TYPE DESCRIPTION	DOC PART	SERIES
REV APPR BY	SAKIYAMA	DATE	2022/05/12	PS	ENGINEERING SPECIFICATION WORD	001	51021
INITIAL RELEASE			CUSTOMER		DOCUMENT NUMBER		REVISION SHEET
INITIAL DRWN	ESUZUKI	DATE	2004/12/14	GENERAL MARKET	PS-51021-009	J	2 OF 12
INITIAL APPR	NUKITA	DATE	2004/12/21				

【4. 性能 PERFORMANCE】

4-1. 電気的性能 Electrical Performance

項目 Item		条件 Test Condition	規格 Requirement
4-1-1	接触抵抗 Contact Resistance	コネクタを嵌合させ、開放電圧 20mV以下、短絡電流 10mA 以下にて測定する。(JIS C5402-2-1) Mate connectors and measured by dry circuit, 20mV MAX, 10mA MAX. (JIS C5402-2-1)	20 milliohms MAX
4-1-2	絶縁抵抗 Insulation Resistance	コネクタを嵌合させ、隣接するターミナル間及びターミナル、アース間に、DC 500V を印加し測定する。(JIS C5402-3-1/MIL-STD-202 試験法 302) Mate connectors, apply 500V DC between adjacent terminal or ground. (JIS C5402-3-1/MIL-STD-202 Method 302)	100 Megohms MIN
4-1-3	耐電圧 Dielectric Strength	コネクタを嵌合させ、隣接するターミナル間及びターミナル、アース間に、AC250V (実効値)を 1分間印加する。 (JIS C5402-4-1/MIL-STD-202 試験法 301) Mate connectors, apply 250V AC(rms) for 1 minute between adjacent terminal or ground. (JIS C5402-4-1/MIL-STD-202 Method 301)	製品機能を損なう 異常なきこと No Damage on function
4-1-4	圧着部接触抵抗 Contact Resistance on Crimped Portion	ターミナルに適合電線を圧着し、開放電圧20mV以下、短絡電流 10mA以下にて測定する。 Crimp the applicable wire to the terminal, measured by dry circuit, 20mV MAX, 10mA MAX.	5 milliohms MAX

THIS DOCUMENT CONTAINS INFORMATION THAT IS PROPRIETARY TO MOLEX ELECTRONIC TECHNOLOGIES, LLC AND SHOULD NOT BE USED WITHOUT WRITTEN PERMISSION

REVISION DESCRIPTION		REVISED		PRODUCT SPECIFICATION FOR PICOBLADE 1.25 W/W TIN PLATING CONNECTOR					
CHANGE NO.	702978								
REVISED BY	QHE31	DATE	2022/03/11	DOC TYPE	DOC TYPE DESCRIPTION		DOC PART	SERIES	
REV APPR BY	SAKIYAMA	DATE	2022/05/12	PS	ENGINEERING SPECIFICATION WORD		001	51021	
INITIAL RELEASE				CUSTOMER		DOCUMENT NUMBER		REVISION	SHEET
INITIAL DRWN	ESUZUKI	DATE	2004/12/14	GENERAL MARKET		PS-51021-009		J	3 OF 12
INITIAL APPR	NUKITA	DATE	2004/12/21						

4-2. 機械的性能 Mechanical Performance

項目 Item		条件 Test Condition	規格 Requirement	
4-2-1	挿入力 及び抜去力 Insertion and Withdrawal Force	毎分 25±3mm の速さで挿入、抜去を行う。 Insert and withdraw connectors at the speed rate of 25±3mm/minute.	第6項参照 Refer to paragraph 6	
4-2-2	圧着部引張強度 Crimping Pull out Force	圧着されたターミナルを治具に固定し、 電線を軸方向に毎分25±3mm の速さで 引張る。 (JIS C5402-16-4) Fix the crimped terminal, apply axial pull out force on the wire at the speed rate of 25±3mm/minute. (JIS C5402-16-4)	AWG #26	19.6 N {2.0kgf} MIN
			AWG #28	9.8 N {1.0kgf} MIN
			AWG #30	4.9 N {0.5kgf} MIN
			AWG #32	3.4 N {0.3kgf} MIN
4-2-3	圧着端子挿入力 Crimp Terminal Insertion Force	圧着されたターミナルをハウジングに挿入 する。 Insert the crimped terminal into the housing.	4.9 N {0.5kgf} MAX	
4-2-4	圧着端子保持力 Crimp Terminal Retention Force	ハウジングに装着した圧着されたターミナル を 毎分 25±3mm の速さで引張る。 Apply axial pull out force at the speed rate of 25±3 mm/minute on the crimped terminal assembled in the housing.	4.9 N {0.5kgf} MIN	

THIS DOCUMENT CONTAINS INFORMATION THAT IS PROPRIETARY TO MOLEX ELECTRONIC TECHNOLOGIES, LLC AND SHOULD NOT BE USED WITHOUT WRITTEN PERMISSION

REVISION DESCRIPTION	REVISED	PRODUCT SPECIFICATION FOR PICOBLADE 1.25 W/W TIN PLATING CONNECTOR					
CHANGE NO.	702978						
REVISED BY	QHE31	DATE	2022/03/11	DOC TYPE	DOC TYPE DESCRIPTION	DOC PART	SERIES
REV APPR BY	SAKIYAMA	DATE	2022/05/12	PS	ENGINEERING SPECIFICATION WORD	001	51021
INITIAL RELEASE				CUSTOMER	DOCUMENT NUMBER	REVISION	SHEET
INITIAL DRWN	ESUZUKI	DATE	2004/12/14	GENERAL MARKET	PS-51021-009	J	4 OF 12
INITIAL APPR	NUKITA	DATE	2004/12/21				

4-3. その他 Environmental Performance and Others

項目 Item		条件 Test Condition	規格 Requirement	
4-3-1	繰り返し挿抜 Repeated Insertion/ Withdrawal	1分間10回以下の速さで、挿入、抜去を30回繰り返す。 Insert and withdraw connectors 30 cycles repeatedly by rate of less than 10 cycles per minute.	接触抵抗 Contact Resistance	40 milliohms MAX
4-3-2	温度上昇 Temperature Rise	コネクタを嵌合させ、全ての圧着端子を直列に接続し最大許容電流で熱平衡に達した時の温度上昇を測定する。(UL498) Mate connectors and all crimp terminals shall be connected in a direct series. The temperature rise shall be measured when the terminal reaches terminal equilibrium allowable current. (UL498)	温度上昇 Temperature Rise	30°C MAX
4-3-3	耐振動性 Vibration	コネクタを嵌合させ、DC 1mA 通電状態にて、嵌合軸を含む互いに垂直な3方向に掃引割合 10~55~10 Hz/分、全振幅 1.5mm の振動を各2時間加える。(ケーブルは固定すること) (JIS C 60068-2-6/MIL-STD-202 試験法 201) Mate connectors and subject to the following vibration conditions, for a period of 2 hours in each of 3 mutually perpendicular axes, passing DC 1mA during the test. (Fix the cable at test.) Amplitude : 1.5mm P-P Frequency : 10~55~10 Hz in 1 minute. Duration : 2 hours in each X Y Z axes. (JIS C 60068-2-6/MIL-STD-202 Method 201)	外観 Appearance	製品機能を損なう異常なきこと No Damage on function
			接触抵抗 Contact Resistance	40 milliohms MAX
			瞬断 Discontinuity	1.0 microsecond MAX
4-3-4	耐衝撃性 Shock	コネクタを嵌合させ、DC 1mA 通電状態にて、テストパルス半周期、嵌合軸を含む互いに垂直な6方向に 490m/s ² { 50G }、作用時間 11msの衝撃を各3回、合計18回加える。 (JIS C60068-2-27/MIL-STD-202 試験法 213) Mate connectors and subject to the following shock conditions. 3 shocks shall be applied along 3 mutually perpendicular axes, passing DC 1 mA current during the test. (Total of 18 shocks) Test pulse : Half Sine Peak value : 490 m/s ² (50 G) Duration : 11 ms (JIS C60068-2-27/MIL-STD-202 Method 213)	外観 Appearance	製品機能を損なう異常なきこと No Damage on function
			接触抵抗 Contact Resistance	40 milliohms MAX
			瞬断 Discontinuity	1.0 microsecond MAX

THIS DOCUMENT CONTAINS INFORMATION THAT IS PROPRIETARY TO MOLEX ELECTRONIC TECHNOLOGIES, LLC AND SHOULD NOT BE USED WITHOUT WRITTEN PERMISSION

REVISION DESCRIPTION	REVISED	PRODUCT SPECIFICATION FOR PICOBLADE 1.25 W/W TIN PLATING CONNECTOR						
CHANGE NO.	702978							
REVISED BY	QHE31	DATE	2022/03/11	DOC TYPE	DOC TYPE DESCRIPTION	DOC PART	SERIES	
REV APPR BY	SAKIYAMA	DATE	2022/05/12	PS	ENGINEERING SPECIFICATION WORD	001	51021	
INITIAL RELEASE				CUSTOMER	DOCUMENT NUMBER	REVISION	SHEET	
INITIAL DRWN	ESUZUKI	DATE	2004/12/14	GENERAL MARKET	PS-51021-009	J	5 OF 12	
INITIAL APPR	NUKITA	DATE	2004/12/21					

項目 Item		条件 Test Condition	規格 Requirement	
4-3-5	耐熱性 Heat Resistance	コネクタを嵌合させ、85±2°Cの雰囲気中に96時間放置後取り出し、1~2時間室温に放置する。 (JIS C60068-2-2/MIL-STD-202 試験法 108) Mate connectors and expose to 85±2°C for 96 hours. Upon completion of the exposure period, the test specimens shall be conditioned at ambient room conditions for 1 to 2 hours, after which the specified measurements shall be performed. (JIS C60068-2-2/MIL-STD-202 Method 108)	外観 Appearance	製品機能を損なう異常なきこと No Damage on function
			接触抵抗 Contact Resistance	40 milliohms MAX
4-3-6	耐寒性 Cold Resistance	コネクタを嵌合させ、-40±3°Cの雰囲気中に96時間放置後取り出し、1~2時間室温に放置する。(JIS C60068-2-1) Mate connectors and expose to -40±3°C for 96 hours. Upon completion of the exposure period, the test specimens shall be conditioned at ambient room conditions for 1 to 2 hours, after which the specified measurements shall be performed. (JIS C60068-2-1)	外観 Appearance	製品機能を損なう異常なきこと No Damage on function
			接触抵抗 Contact Resistance	40 milliohms MAX
4-3-7	耐湿性 Humidity	コネクタを嵌合させ、60±2°C、相対湿度90~95%の雰囲気中に96時間放置後取り出し、1~2時間室温に放置する。 (JIS C60068-2-78/MIL-STD-202 試験法 103) Mate connectors and expose to 60±2°C, relative humidity 90 to 95% for 96 hours. Upon completion of the exposure period, the test specimens shall be conditioned at ambient room conditions for 1 to 2 hours, after which the specified measurements shall be performed. (JIS C60068-2-78/MIL-STD-202 Method 103)	外観 Appearance	製品機能を損なう異常なきこと No Damage on function
			接触抵抗 Contact Resistance	40 milliohms MAX
			耐電圧 Dielectric Strength	4-1-3項を満たすこと Must meet 4-1-3
			絶縁抵抗 Insulation Resistance	10 Megohms MIN

THIS DOCUMENT CONTAINS INFORMATION THAT IS PROPRIETARY TO MOLEX ELECTRONIC TECHNOLOGIES, LLC AND SHOULD NOT BE USED WITHOUT WRITTEN PERMISSION

REVISION DESCRIPTION	REVISED	PRODUCT SPECIFICATION FOR PICOBLADE 1.25 W/W TIN PLATING CONNECTOR					
CHANGE NO.	702978						
REVISED BY	QHE31	DATE	2022/03/11	DOC TYPE	DOC TYPE DESCRIPTION	DOC PART	SERIES
REV APPR BY	SAKIYAMA	DATE	2022/05/12	PS	ENGINEERING SPECIFICATION WORD	001	51021
INITIAL RELEASE				CUSTOMER	DOCUMENT NUMBER	REVISION	SHEET
INITIAL DRWN	ESUZUKI	DATE	2004/12/14	GENERAL MARKET	PS-51021-009	J	6 OF 12
INITIAL APPR	NUKITA	DATE	2004/12/21				

項目 Item		条件 Test Condition	規格 Requirement	
4-3-8	温度サイクル Temperature Cycling	コネクタを嵌合させ、 $-55\pm 3^{\circ}\text{C}$ に30分、 $+105\pm 2^{\circ}\text{C}$ に30分。これを1サイクルとし、5サイクル繰返す。 但し、温度移行時間は5分以内とする。 試験後1~2時間室温に放置する。 (JIS C60068-2-14) Mate connectors and subject to the following conditions for 5 cycles. Upon completion of the exposure period, the test specimens shall be conditioned at ambient room conditions for 1 to 2 hours, after which the specified measurements shall be performed. 5 cycles of : a) $-55\pm 3^{\circ}\text{C}$ 30 minutes b) $+105\pm 2^{\circ}\text{C}$ 30 minutes (JIS C60068-2-14)	外観 Appearance	製品機能を損なう異常なきこと No Damage on function
			接触抵抗 Contact Resistance	40 milliohms MAX
4-3-9	塩水噴霧 Salt Spray	コネクタを嵌合させ、 $35\pm 2^{\circ}\text{C}$ にて $5\pm 1\%$ 重量比の塩水を 48 ± 4 時間噴霧し、試験後常温で水洗いした後、室温で乾燥させる。 (JIS C60068-2-11/MIL-STD-202 試験法101) Mate connectors and expose to the following salt mist conditions. Upon completion of the exposure period, salt deposits shall be removed by a gentle wash or dip in running water, after which the specified measurements shall be performed. NaCl solution Concentration : $5\pm 1\%$ Spray time : 48 ± 4 hours Ambient temperature : $35\pm 2^{\circ}\text{C}$ (JIS 60068-2-11/MIL-STD-202 Method 101)	外観 Appearance	製品機能を損なう異常なきこと No Damage on function
			接触抵抗 Contact Resistance	40 milliohms MAX
4-3-10	亜硫酸ガス SO ₂ Gas	コネクタを嵌合させ、 $40\pm 2^{\circ}\text{C}$ にて $50\pm 5\text{ppm}$ の亜硫酸ガス中に24時間放置する。 Mated connectors and expose to the conditions of $50\pm 5\text{ppm}$ SO ₂ gas ambient temperature $40\pm 2^{\circ}\text{C}$ for 24 hours.	外観 Appearance	製品機能を損なう異常なきこと No Damage on function
			接触抵抗 Contact Resistance	40 milliohms MAX

THIS DOCUMENT CONTAINS INFORMATION THAT IS PROPRIETARY TO MOLEX ELECTRONIC TECHNOLOGIES, LLC AND SHOULD NOT BE USED WITHOUT WRITTEN PERMISSION

REVISION DESCRIPTION	REVISED	PRODUCT SPECIFICATION FOR PICOBLADE 1.25 W/W TIN PLATING CONNECTOR						
CHANGE NO.	702978							
REVISED BY	QHE31	DATE	2022/03/11	DOC TYPE	DOC TYPE DESCRIPTION	DOC PART	SERIES	
REV APPR BY	SAKIYAMA	DATE	2022/05/12	PS	ENGINEERING SPECIFICATION WORD	001	51021	
INITIAL RELEASE				CUSTOMER	DOCUMENT NUMBER	REVISION	SHEET	
INITIAL DRWN	ESUZUKI	DATE	2004/12/14	GENERAL MARKET	PS-51021-009	J	7 OF 12	
INITIAL APPR	NUKITA	DATE	2004/12/21					

項目 Item		条件 Test Condition	規格 Requirement	
4-3-11	耐アンモニア性 NH ₃ Gas	コネクタを嵌合させ、濃度28%のアンモニア水を入れた容器中に40分間放置する。 (1Lに対して25mLの割合) Mated connectors and expose to the conditions of NH ₃ gas evaporating from 28% NH ₃ solution for 40 minutes. (Rate is 25ml per 1L)	外観 Appearance	製品機能を損なう異常なきこと No Damage on function
			接触抵抗 Contact Resistance	40 milliohms MAX

() : 参考規格 Reference Standard
{ } : 参考単位 Reference Unit

【5. 外観形状、寸法及び材質 PRODUCT SHAPE, DIMENSIONS AND MATERIALS】

5-1. 製品寸法及び材質 Dimensions and materials of product.

図面参照 Refer to the drawing.

【6. 挿入力及び抜去力 INSERTION / WITHDRAWAL FORCE】

極数 No of CKT	単位 Unit	挿入力 (最大値) Insertion force (MAX)			抜去力 (最小値) Withdrawal force (MIN)		
		初回 1st	6回目 6th	30回目 30th	初回 1st	6回目 6th	30回目 30th
2	N { kgf }	24.5 { 2.5 }	17.6 { 1.8 }	15.6 { 1.6 }	2.8 { 0.28 }	2.3 { 0.23 }	1.8 { 0.18 }
3	N { kgf }	29.4 { 3.0 }	22.5 { 2.3 }	20.5 { 2.1 }	3.0 { 0.30 }	2.5 { 0.25 }	2.0 { 0.20 }
4	N { kgf }	34.3 { 3.5 }	27.4 { 2.8 }	25.4 { 2.6 }	3.3 { 0.33 }	2.8 { 0.28 }	2.3 { 0.23 }
5	N { kgf }	39.2 { 4.0 }	32.3 { 3.3 }	30.3 { 3.1 }	3.8 { 0.38 }	3.3 { 0.33 }	2.8 { 0.28 }
6	N { kgf }	44.1 { 4.5 }	37.2 { 3.8 }	35.2 { 3.6 }	4.3 { 0.43 }	3.8 { 0.38 }	3.3 { 0.33 }
7	N { kgf }	49.0 { 5.0 }	42.1 { 4.3 }	40.1 { 4.1 }	4.7 { 0.48 }	4.3 { 0.43 }	3.8 { 0.38 }
8	N { kgf }	53.9 { 5.5 }	47.0 { 4.8 }	45.0 { 4.6 }	5.2 { 0.53 }	4.7 { 0.48 }	4.3 { 0.43 }
9	N { kgf }	58.8 { 6.0 }	51.9 { 5.3 }	49.9 { 5.1 }	5.5 { 0.56 }	5.0 { 0.51 }	4.5 { 0.46 }
10	N { kgf }	63.7 { 6.5 }	56.8 { 5.8 }	54.8 { 5.6 }	5.8 { 0.59 }	5.3 { 0.54 }	4.8 { 0.49 }

THIS DOCUMENT CONTAINS INFORMATION THAT IS PROPRIETARY TO MOLEX ELECTRONIC TECHNOLOGIES, LLC AND SHOULD NOT BE USED WITHOUT WRITTEN PERMISSION

REVISION DESCRIPTION	REVISED	PRODUCT SPECIFICATION FOR PICOBLADE 1.25 W/W TIN PLATING CONNECTOR							
CHANGE NO.	702978								
REVISED BY	QHE31	DATE	2022/03/11	DOC TYPE	DOC TYPE DESCRIPTION		DOC PART	SERIES	
REV APPR BY	SAKIYAMA	DATE	2022/05/12	PS	ENGINEERING SPECIFICATION WORD		001	51021	
INITIAL RELEASE			CUSTOMER		DOCUMENT NUMBER		REVISION	SHEET	
INITIAL DRWN	ESUZUKI	DATE	2004/12/14	GENERAL MARKET		PS-51021-009		J	8 OF 12
INITIAL APPR	NUKITA	DATE	2004/12/21						

【7. 圧着端子取り扱い上の注意事項 INSTRUCTION UPON USAGE OF CRIMP TERMINAL.】

1. 圧着端子取り扱いについて、AS-56000-001をご参照お願いします。
Please refer to AS-56000-001 for usage of CRIMP TERMINAL.

【8. 注記 NOTES.】

1. 本製品のプラスチック部に黒点、気泡等が確認される場合や色合いが異なる場合（経年変化によるハウジングの変色を含む）が御座いますが、製品性能に影響は御座いません。
There is no influence in the product performance though the black spot or bubble etc. might be confirmed to the plastic part of this product and the shade might be different (discoloration by secular distortion etc.).
2. 本製品は錫めっきを使用している為、外観に摺動痕がつく場合が御座いますが、製品性能に影響は御座いません。
The wound of friction might adhere to externals because the tin plating is used for the tail and nail. But there is no influence in the product performance.
3. 本製品のハウジング及びめっき表面に多少の傷が確認される場合がありますが、製品性能に問題御座いません。
A few scratches may be confirmed to the surface of the housing and the plating of this product, however, There is no problem in the product performance.
4. 本製品のプラスチック部が紫外線により変色する場合がありますが、製品性能には問題御座いません。
Discoloration of the plastic part of this product can result from exposure to ultraviolet light. There is no problem in the product performance.
5. コネクタの性能を損なう恐れがある為、コネクタの洗浄は、行わないでください。
Please do not conduct any washing process on the connectors because it may damage the product's function.
6. 本製品をご使用時に取り付けられた電線・プリント基板の共振や、機器の回転構造や可動部分の動作によりコネクタ嵌合部（接点部）が常に動いてしまう状態での御使用は避けてください。
接触部の摺動磨耗等による 接触不良の原因となります。
従って、機器内で電線・プリント基板を固定し、共振を抑える等の処置をお願い致します。
Please do not use the connectors in a condition where the wire, PWB, or the contact area is experiencing a sympathetic vibration of wires and PWB, and constant movement of devices. This may cause a defect in the contact due to the contact area being worn down. Therefore, please fix wires and PWB on the chassis, and reduces sympathetic vibration.
7. コネクタ嵌合状態で基板の持ち運び等コネクタに負荷が掛かる作業は行わないようにしてください。
コネクタ破損等の原因となる場合が御座います。
Please do not do work that the load hangs in the connectors like the carrying of the substrate etc. with the connectors engages. There is a case where it causes the connectors damage etc.

THIS DOCUMENT CONTAINS INFORMATION THAT IS PROPRIETARY TO MOLEX ELECTRONIC TECHNOLOGIES, LLC AND SHOULD NOT BE USED WITHOUT WRITTEN PERMISSION

REVISION DESCRIPTION		REVISED		PRODUCT SPECIFICATION FOR PICOBLADE 1.25 W/W TIN PLATING CONNECTOR					
CHANGE NO.	702978								
REVISED BY	QHE31	DATE	2022/03/11	DOC TYPE	DOC TYPE DESCRIPTION		DOC PART	SERIES	
REV APPR BY	SAKIYAMA	DATE	2022/05/12	PS	ENGINEERING SPECIFICATION WORD		001	51021	
INITIAL RELEASE				CUSTOMER		DOCUMENT NUMBER		REVISION	SHEET
INITIAL DRWN	ESUZUKI	DATE	2004/12/14	GENERAL MARKET		PS-51021-009		J	9 OF 12
INITIAL APPR	NUKITA	DATE	2004/12/21						

8. 嵌合後、コネクタピッチ方向、スパン方向及び回転方向への負荷がかかるような動作またはセットはしないでください。コネクタ破壊やはんだクラックを引き起こします。
After mated the connectors, please do not allow the PWBs to apply pressure on the connectors in either the pitch direction, the span direction or rotational direction. It may cause damage to the connectors and may crack the soldering.
9. 本製品及び加工工程品（仕掛品）や加工品（ハーネス等）の梱包及び輸送・保管時にはコネクタに負荷が加わらないようご注意ください。変形、破損などの原因となり、コネクタの性能不良の原因となります。
Please try to prevent any external forces or shock from being applied to the connectors while the cable assembly is in process, when it is being packaged, or while it is in transportation. This may cause deformation and damage to the connectors and cause a defect in the product's performance.
10. 本製品をご使用時には、1PIN当りの定格以上の電流を複数の回路に分岐しての使用は避けてください。
When using this product, please ensure that the specification for rated current per circuit is followed. Do not allow the sum of the current used on several circuits to exceed the maximum allowable current.
11. 活電状態の電気回路で、挿入、抜去ができることを前提に作られておりません。スパーク等による危険の発生、性能不良につながりますので、活電状態での挿入、抜去はしないでください。
This product is not designed for the mating and unmating of the connectors to be performed under the condition of an active electrical circuit. It may cause a spark and product defect if the connectors are mated and unmated in this way.
12. コネクタに適用できる電線は、原則として錫めっきつき付軟銅撚り線です。その他の電線の使用については別途ご確認ください。
The applicable wire for this connectors, in principle, is tin-plated copper stranded wire. Please consult us and evaluate it in advance when using other wires.
13. コネクタに外力が加わらないようにクリアランスをあげた筐体構造にしてください。
Please keep enough clearance between connectors and chassis of your application in order not to apply pressure on the connectors.
14. 電線の結束はコネクタから50mm以上のところで、電線に加わる力が均一になるようにしてください。ハーネス品で電線一本（又は特定の数本）に力が加わらない様にしてください。
Please tie the cable at least 50mm away from the edge of the connectors and try to ensure that the force is applied evenly on all of the wires.
15. 治具等を使用して圧着端子を抜いた場合には、ランスが変形し強度が低下し端子を再装着後の端子保持力が極端に低下します。そのため、圧着端子のリペアの際には新しいハウジングを必ず使用してください。
When extracting a crimp terminal from the housing using a jig, it may deform the housing lance and therefore reduce the terminal retention force enormously after re-inserting of the terminal. Therefore, please ensure to use a new housing after repairing the crimp terminals.

THIS DOCUMENT CONTAINS INFORMATION THAT IS PROPRIETARY TO MOLEX ELECTRONIC TECHNOLOGIES, LLC AND SHOULD NOT BE USED WITHOUT WRITTEN PERMISSION

REVISION DESCRIPTION		REVISED		PRODUCT SPECIFICATION FOR PICOBLADE 1.25 W/W TIN PLATING CONNECTOR					
CHANGE NO.		702978							
REVISED BY	QHE31	DATE	2022/03/11	DOC TYPE	DOC TYPE DESCRIPTION	DOC PART	SERIES		
REV APPR BY	SAKIYAMA	DATE	2022/05/12	PS	ENGINEERING SPECIFICATION WORD	001	51021		
INITIAL RELEASE				CUSTOMER		DOCUMENT NUMBER		REVISION	SHEET
INITIAL DRWN	ESUZUKI	DATE	2004/12/14	GENERAL MARKET		PS-51021-009		J	10 OF 12
INITIAL APPR	NUKITA	DATE	2004/12/21						

16. ハーネス加工品及びコネクタ嵌合後の電線の引き回しの際、引張りによる力が加わりますと、接点部、結線部（圧着部）やロック部（端子ロック部）が損傷を受け、接触不良の原因となります。電線の引直し配線をされる場合、コネクタに無理な外力が加わらないように、電線に緩みを持たせ、余裕を持たせる処置をしてください。
The cable assembly should not have a constant stress or pulling force applied on it when it is in the mated condition. This phenomenon may damage the contact area or wiring area (crimping). Therefore, when designing the wire positioning, please ensure that there is enough length of wire to avoid stress on the connectors.
17. 電線はまとめて軽くつかみ、ゆっくり、軸方向にまっすぐに引き抜いてください。また、斜めにこじりながら抜くことは避けてください。コネクタを破損させる恐れが御座います。
Please hold wires all together lightly and withdraw receptacle housing slowly, axially and straightly. Please avoid withdrawing them with an angle and roughly. That might cause damage to connector.
- 18.ハウジングのロック部やランス部などの可動部、及び端子を故意に変形させないでください。製品性能が満足出来ない原因となります。
Do not deform the movable part as lock part and lance part of Plug, HS'G and terminals on purpose. It would lead to product failure.
19. 嵌合は極力嵌合軸に沿って平行に行ってください。その際、リセハウジングとプラグの外壁同士を合せる様に位置決めした後に押し込み、コネクタ同士が突き当たる（完全嵌合位置）まで真っ直ぐ押し込んでください。斜めの嵌合になる場合は10°以下の角度でリセハウジングとプラグの外壁同士を軽く当て、位置決めした後に嵌合してください。尚、コネクタ同士を過度に傾けた状態で嵌合を行いますと、ハウジングが破壊する恐れがありますのでこのような嵌合は避けください。
Please do the mating as much as possible to along to mating axis. At this time, positioning each side of external faces of receptacle housing and plug and push to mating until both connectors strikes each other (complete mating position). In the case of diagonal mating, touch with external faces with receptacle housing and plug under the angle of 10°lightly, and push to mating in order to avoid the connector break.

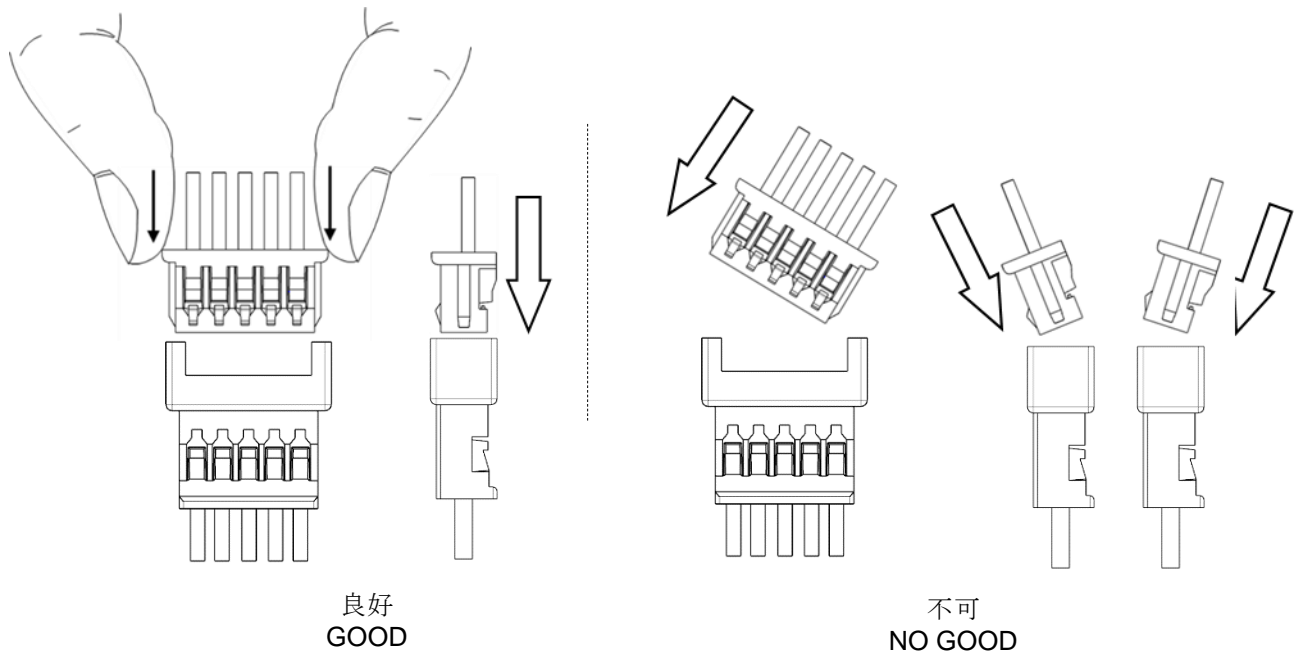

良好
GOOD

不可
NO GOOD

THIS DOCUMENT CONTAINS INFORMATION THAT IS PROPRIETARY TO MOLEX ELECTRONIC TECHNOLOGIES, LLC AND SHOULD NOT BE USED WITHOUT WRITTEN PERMISSION

REVISION DESCRIPTION		REVISED		PRODUCT SPECIFICATION FOR PICOBLADE 1.25 W/W TIN PLATING CONNECTOR				
CHANGE NO.		702978						
REVISED BY	QHE31	DATE	2022/03/11	DOC TYPE	DOC TYPE DESCRIPTION	DOC PART	SERIES	
REV APPR BY	SAKIYAMA	DATE	2022/05/12	PS	ENGINEERING SPECIFICATION WORD	001	51021	
INITIAL RELEASE				CUSTOMER		DOCUMENT NUMBER		
INITIAL DRWN	ESUZUKI	DATE	2004/12/14	GENERAL MARKET		PS-51021-009		
INITIAL APPR	NUKITA	DATE	2004/12/21					
						REVISION	SHEET	
						J	11 OF 12	

20. 本製品のレセプタクルハウジング材料はポリアミドを使用しており、吸水状態によって挿抜力・挿入感が変わります。過度な吸水により、挿入時に嵌合相手と若干干渉する場合や、クリック感が弱くなる場合がありますが、製品性能、機能には問題ございません。
 Because the receptacle housing material of this product is using polyamide, the water absorption status of the housing material might change insertion force, withdrawal force, or the feeling of insertion. Its excessive water absorption may cause to interfere with insertion a little bit or to weaken the click feeling of the lock when mating. However it does not damage the product's features and functions.

【9. 接触抵抗測定箇所 CONTACT RESISTANCE MEASURING POINT】

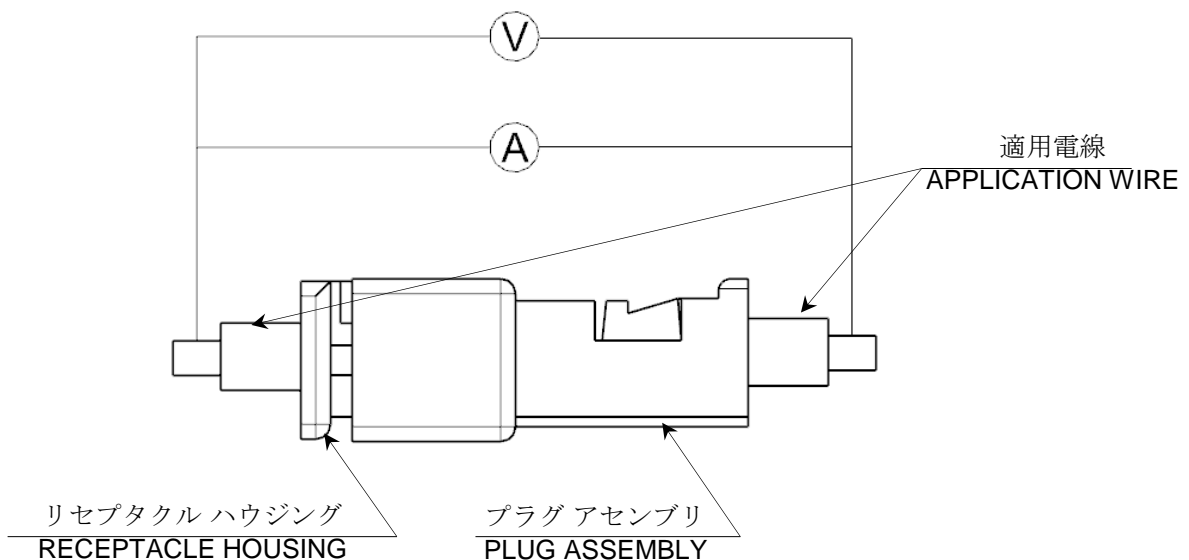

接触抵抗 Contact Resistance
 $m\Omega = V/A$

THIS DOCUMENT CONTAINS INFORMATION THAT IS PROPRIETARY TO MOLEX ELECTRONIC TECHNOLOGIES, LLC AND SHOULD NOT BE USED WITHOUT WRITTEN PERMISSION

REVISION DESCRIPTION		REVISED		PRODUCT SPECIFICATION FOR PICOBLADE 1.25 W/W TIN PLATING CONNECTOR					
CHANGE NO.		702978							
REVISED BY	QHE31	DATE	2022/03/11	DOC TYPE	DOC TYPE DESCRIPTION	DOC PART	SERIES		
REV APPR BY	SAKIYAMA	DATE	2022/05/12	PS	ENGINEERING SPECIFICATION WORD	001	51021		
INITIAL RELEASE				CUSTOMER		DOCUMENT NUMBER		REVISION	SHEET
INITIAL DRWN	ESUZUKI	DATE	2004/12/14	GENERAL MARKET		PS-51021-009		J	12 OF 12
INITIAL APPR	NUKITA	DATE	2004/12/21						