

1.0 Scope

This specification covers the Molex MicroCross™ - Digital Visual Interface (DVI) system which includes cable plugs and board mount receptacles (Right Angle and Vertical).

The Digital Visual Interface connector system supports both analog and digital video transmission.

This specification covers the DVI cable to board, I/O connector system with requirements as set forth by Molex Incorporated.

2.0 Product Description

The MicroCross™ DVI system is designed to meet the industry’s requirements for analog and digital computer monitors. There are (2) different receptacle connectors which correspond to the video support present on the host system (mother board/graphics cards). The DVI-D (Digital) receptacle connector supports hosts systems that transmit digital video. The DVI-I (Integrated) receptacle connector supports host systems that are enabled to transmit both analog and digital video. This is achieved by utilizing two different sets of contacts as shown in Figure 1 below:

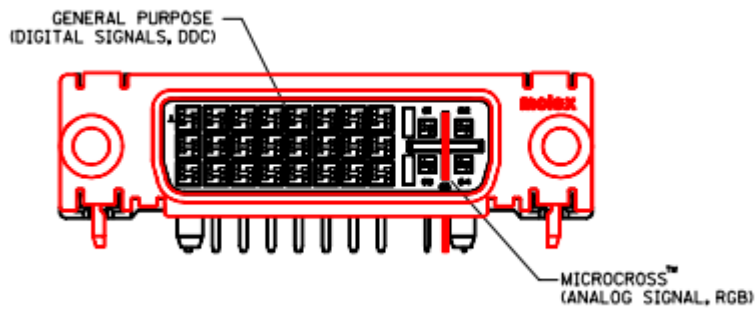

Figure 1: Two sets of contacts (DVI-I Shown)

THIS DOCUMENT CONTAINS INFORMATION THAT IS PROPRIETARY TO MOLEX ELECTRONIC TECHNOLOGIES, LLC AND SHOULD NOT BE USED WITHOUT WRITTEN PERMISSION

REVISION DESCRIPTION	REMASTERED			MIROCROSSTM - DVI I/O PLUG AND RECEPTACLE CONNECTOR SYSTEM			
CHANGE NO.	712023			DOC TYPE	DOC TYPE DESCRIPTION	DOC PART	SERIES
REVISED BY	MKP	DATE	2022/06/10	PS	ENGINEERING SPECIFICATION WORD	001	74320
REV APPR BY	RLI09	DATE	2022/06/28	INITIAL RELEASE		CUSTOMER	DOCUMENT NUMBER
INITIAL DRWN	RFC_PLMIMP	DATE	2020/12/19	GENERAL MARKET		PS-74320-001	REVISION
INITIAL APPR	RNELSON	DATE	2000/10/19			J1	SHEET
							1 OF 14

1. General purpose signals:
 Terminals: 24 circuits on a 0.075 inch/1.91 mm grid
 Signals: Includes power, grounds, digital and video signals, analog synch lines and DDC (Display Data Channel) signals.

Pin	Signal Assignment	Pin	Signal Assignment	Pin	Signal Assignment
1	T.M.D.S. Data2-	9	T.M.D.S. Data1-	17	T.M.D.S. Data 0-
2	T.M.D.S. Data2+	10	T.M.D.S. Data1+	18	T.M.D.S. Data 0+
3	T.M.D.S. Data2/4 Shield	11	T.M.D.S. Data 1/3 Shield	19	T.M.D.S. Data 0/5 Shield
4	T.M.D.S. Data 4-	12	T.M.D.S. Data 3-	20	T.M.D.S. Data 5-
5	T.M.D.S. Data 4+	13	T.M.D.S. 3+	21	T.M.D.S. Data 5+
6	DDC Clock	14	+5 V Power	22	T.M.D.S. Clock Shield
7	DDC Data	15	Ground (for +5V)	23	T.M.D.S. Clock+
8	No Connect	16	Hot Plug Detect	24	T.M.D.S. Clock-

Table 1: Digital-Only Connector Pin Assignments
 Source: Digital Visual Interface Specification, Revision 1.0

2. MicroCross™:
 - a) Plug and Receptacle - I - Intergrated analog/digital - see figure 3, sheet 3
 Terminals: 4 circuits on a 0.100 inch/2.54 mm grid with a crossing ground plane in between.
 Signals: High frequency, 75-ohm, analog video
 - b) Plug and Receptacle - D - Digital Version
 Terminals: A single key on the plug and corresponding slot on the receptacle.
 Signals: The key is used for mechanical polarization only, it does not carry any electrical signals.

Pin	Signal Assignment	Pin	Signal Assignment	Pin	Signal Assignment
1	T.M.D.S. Data2-	9	T.M.D.S. Data1-	17	T.M.D.S. Data 0-
2	T.M.D.S. Data2+	10	T.M.D.S. Data1+	18	T.M.D.S. Data 0+
3	T.M.D.S. Data2/4 Shield	11	T.M.D.S. Data 1/3 Shield	19	T.M.D.S. Data 0/5 Shield
4	T.M.D.S. Data 4-	12	T.M.D.S. Data 3-	20	T.M.D.S. Data 5-
5	T.M.D.S. Data 4+	13	T.M.D.S. Data 3+	21	T.M.D.S. Data 5+
6	DDC Clock	14	+5 V Power	22	T.M.D.S. Clock Shield
7	DDC Data	15	Ground (Return for +5V, HSync, and VSync)	23	T.M.D.S. Clock+
8	Analog Vertical Sync	16	Hot Plug Detect	24	T.M.D.S. Clock-
C1	Analog Red	C2	Analog Green	C3	Analog Blue
C4	Analog Horizontal Sync	C5	Analog Ground (Analog R, G, & B return)		

Table 2: Combined Analog and Digital Connector Pin Assignments
 Source: Digital Visual Interface, Revision 1.0

THIS DOCUMENT CONTAINS INFORMATION THAT IS PROPRIETARY TO MOLEX ELECTRONIC TECHNOLOGIES, LLC AND SHOULD NOT BE USED WITHOUT WRITTEN PERMISSION

REVISION DESCRIPTION	REMASTERED			MIROCROSSTM - DVI I/O PLUG AND RECEPTACLE CONNECTOR SYSTEM			
CHANGE NO.	712023			DOC TYPE	DOC TYPE DESCRIPTION	DOC PART	SERIES
REVISED BY	MKP	DATE	2022/06/10	PS	ENGINEERING SPECIFICATION WORD	001	74320
REV APPR BY	RLI09	DATE	2022/06/28	INITIAL RELEASE		CUSTOMER	DOCUMENT NUMBER
INITIAL DRWN	RFC_PLMIMP	DATE	2020/12/19	GENERAL MARKET		PS-74320-001	REVISION
INITIAL APPR	RNELSON	DATE	2000/10/19			J1	SHEET
							2 OF 14

Additional general specifications are:

Plug:

- LFH (Low Force Helix) style contacts
- fully shielded RFI/EMI can
- grounding detents on mating shell
- solder tails for cable termination
- positive retention jackscrew: thread 4-40 UNC-2A

Receptacle:

- high cycle, dual beam, LFH shrouded contacts
- polarization achieved by a "D" shaped housing/shield
- single piece shield with integral ground leg
- shield protrudes for ESD considerations
- solder tails for thru hole board mount
- plastic retention pegs
- jackposts: # 4-40 UNC-2A&B threads. The recommended application torque setting is 4 lbf in maximum. To prevent stripping the shield threads while installing the jackposts, it is recommended the jackposts are started by hand or with a lower initial torque driver setting. The engaged threads are rated to hold a minimum of 5 lbf in of torque.

2.1 Product Drawing Numbers

2.1.1 Receptacle:

The DVI receptacle is for systems which support digital video (DVI-D) or both analog and digital video (DVI-I).

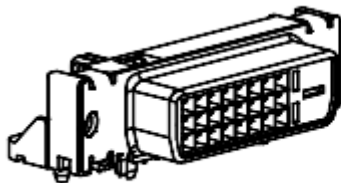

Figure 2:
Right Angle DVI-D version
(Digital)

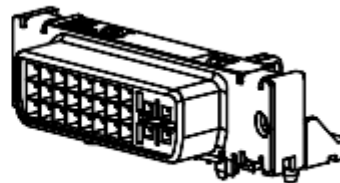

Figure 3:
Right Angle DVI-I version
Integrated(Analog/Digital)



Figure 4: Jackpost

THIS DOCUMENT CONTAINS INFORMATION THAT IS PROPRIETARY TO MOLEX ELECTRONIC TECHNOLOGIES, LLC AND SHOULD NOT BE USED WITHOUT WRITTEN PERMISSION

REVISION DESCRIPTION	REMASTERED			MIROCROSSTM - DVI I/O PLUG AND RECEPTACLE CONNECTOR SYSTEM			
CHANGE NO.	712023			DOC TYPE	DOC TYPE DESCRIPTION	DOC PART	SERIES
REVISED BY	MKP	DATE	2022/06/10	PS	ENGINEERING SPECIFICATION WORD	001	74320
REV APPR BY	RLI09	DATE	2022/06/28	INITIAL RELEASE		CUSTOMER	DOCUMENT NUMBER
INITIAL DRWN	RFC_PLMIMP	DATE	2020/12/19	GENERAL MARKET		REVISION	SHEET
INITIAL APPR	RNELSON	DATE	2000/10/19			J1	3 OF 14
						PS-74320-001	

2.1.2 DVI Plug

The DVI plug is for systems which use analog or digital video. The analog DVI plug shown below supports analog video transmission from the host to the display.

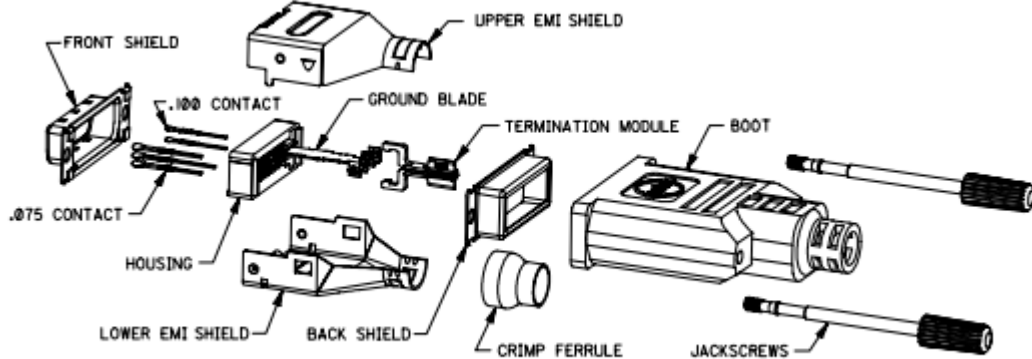

Figure 5:
Analog Version

2.1.3

The digital DVI plug shown below supports digital video transmission from the host to the display.

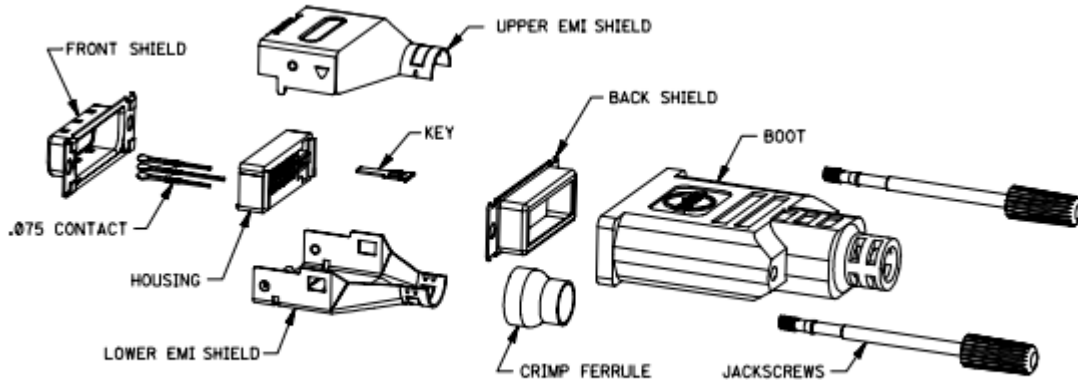

Figure 6:
Digital Version

2.2 Safety Agency Approvals

UL File Number E29179, Volume 10, Section 12
CSA File Number LR19980

THIS DOCUMENT CONTAINS INFORMATION THAT IS PROPRIETARY TO MOLEX ELECTRONIC TECHNOLOGIES, LLC AND SHOULD NOT BE USED WITHOUT WRITTEN PERMISSION

REVISION DESCRIPTION	REMASTERED			MIROCROSSTM - DVI I/O PLUG AND RECEPTACLE CONNECTOR SYSTEM				
CHANGE NO.	712023							
REVISED BY	MKP	DATE	2022/06/10	DOC TYPE	DOC TYPE DESCRIPTION	DOC PART	SERIES	
REV APPR BY	RLI09	DATE	2022/06/28	PS	ENGINEERING SPECIFICATION WORD	001	74320	
INITIAL RELEASE				CUSTOMER		DOCUMENT NUMBER	REVISION	SHEET
INITIAL DRWN	RFC_PLMIMP	DATE	2020/12/19	GENERAL MARKET		PS-74320-001	J1	4 OF 14
INITIAL APPR	RNELSON	DATE	2000/10/19					

3.0 Applicable Documents and Specifications

3.1 All documents referenced shall be of the latest revision. The order of precedence detailing requirements of this specification is as follows:

- 1. Product Drawings
- 2. This specification

3.2 Reference Documents

- 3.2.1 EIA RS-364-(06,09,13,17,18,20,21,23,27,28,31,32,41,46,65,67,70,90) Electronic Industries Association, Recommended Standard
- 3.2.2 IEC-801-2 International Electrotechnical Commission, Electrostatic Discharge Requirements
- 3.2.3 MIL STD-202: Test methods for electronics and electrical component parts
- 3.2.4 Molex PS-74320-9999 Application Specification, DVI Plug Cable Assembly
- 3.2.5 Molex ES-74320-9998 Termination Specification, DVI Cable Assemblies
- 3.2.6 Molex PS-74320-9997 Cable Assembly Specification
- 3.2.7 UL 94: Tests for flammability of plastics materials

4.0 Ratings

4.1 Voltage

40 Volts AC (RMS)

4.2 Current

3.0 Amps per circuit.
30 °C maximum temperature rise and 55 °C maximum ambient per EIA-364-70.

4.3 Temperature

Operating: - 20 °C to + 85 °C
Nonoperating: - 20 °C to + 85 °C

THIS DOCUMENT CONTAINS INFORMATION THAT IS PROPRIETARY TO MOLEX ELECTRONIC TECHNOLOGIES, LLC AND SHOULD NOT BE USED WITHOUT WRITTEN PERMISSION

REVISION DESCRIPTION	REMASTERED			MIROCROSSTM - DVI I/O PLUG AND RECEPTACLE CONNECTOR SYSTEM			
CHANGE NO.	712023						
REVISED BY	MKP	DATE	2022/06/10	DOC TYPE	DOC TYPE DESCRIPTION	DOC PART	SERIES
REV APPR BY	RLI09	DATE	2022/06/28	PS	ENGINEERING SPECIFICATION WORD	001	74320
INITIAL RELEASE				CUSTOMER	DOCUMENT NUMBER	REVISION	SHEET
INITIAL DRWN	RFC_PLMIMP	DATE	2020/12/19	GENERAL MARKET	PS-74320-001	J1	5 OF 14
INITIAL APPR	RNELSON	DATE	2000/10/19				

5.0 Performance

5.1 Electrical Performance

ITEM	TEST CONDITION	REQUIREMENT
Contact Resistance	Bulk resistance measured between plug solder tails and receptacle solder tails per ANSI/EIA-364-23	20 milliohm maximum, initial per contact mated pair 10 milliohm maximum change from initial reading per contact mated pair
Shell Resistance	Bulk resistance measured between ground leg on receptacle shield and the plug cable braid. Test current=100mA; Test voltage=5 Volts DC open circuit maximum per ANSI/EIA-364-06A-83	50 milliohm maximum initial 50 milliohm maximum change from initial reading
Insulation Resistance	Test voltage = 500 Volts DC +/- 50 V Unmated and unmounted per ANSI/EIA 364-21, Method C	1Gigaohm Minimum between adjacent contacts and contacts and shell
Dielectric Withstanding Voltage	Test voltage = 500 Volts DC +/-50 V Unmated and Unmounted per ANSI/EIA 364-20, Method C Barometric pressure of 15 psi	No flashover, No sparkover, No excess leakage, No Breakdown
Contact Current Rating	Maximum ambient = 55 degree C Maximum temperature change = 85 degree C per ANSI/EIA-364-70, TP-70	3.0 A maximum
Applied Voltage Rating		40 Volts AC (rms) continuous maximum, on any signal pin with respect to the shield
Electrostatic Discharge	Test unmated from 1 kV to 8kV in 1 kV steps using 8mm ball prob per IEC 801-2 Contact discharge to shell Air discharge perpendicular to shell Air discharge at angle to shell	No evidence of discharge to contacts at 8kV. Discharge to the shell is acceptable.
T.M.D.S. Signals Time Domain Impedance	Risetime = 330 pS (10%-90%) S:G ratio per DVI pin designation Differential Measurement Specimen Environment Impedance = 100 ohm differential Source-side receptacle connector mounted on a controlled impedance pcb fixture per ANSI/EIA-364-108 draft Proposal	100 ohms +/-15%
T.M.D.S. Signals Time Domain Crosstalk: FEXT	Risetime = 330 pS (10%-90%) S:G ratio per DVI pin designation Differential Measurement Specimen Environment Impedance = 100 ohm differential Source-side receptacle and the load side plug connector are mounted on a controlled impedance pcb fixture (1) Driven pair and (1) victim pair per ANSI/EIA-364-90 Draft Proposal	5% Maximum

THIS DOCUMENT CONTAINS INFORMATION THAT IS PROPRIETARY TO MOLEX ELECTRONIC TECHNOLOGIES, LLC AND SHOULD NOT BE USED WITHOUT WRITTEN PERMISSION

REVISION DESCRIPTION	REMASTERED			MIROCROSSTM - DVI I/O PLUG AND RECEPTACLE CONNECTOR SYSTEM			
CHANGE NO.	712023			DOC TYPE	DOC TYPE DESCRIPTION	DOC PART	SERIES
REVISED BY	MKP	DATE	2022/06/10	PS	ENGINEERING SPECIFICATION WORD	001	74320
REV APPR BY	RLI09	DATE	2022/06/28	INITIAL RELEASE		CUSTOMER	DOCUMENT NUMBER
INITIAL DRWN	RFC_PLMIMP	DATE	2020/12/19	GENERAL MARKET		PS-74320-001	REVISION
INITIAL APPR	RNELSON	DATE	2000/10/19			J1	SHEET
							6 OF 14

T.M.D.S. Signals Rise Time Degradation	S:G ratio per DVI pin designation Differential Measurement Specimen Environment Impedance = 100 ohm differential Source-side receptacle and the load side plug connector are mounted on a controlled impedance pcb fixture per ANSI/EIA-364-102 Draft Proposal	160 pS Maximum (Note: Converted bandwidth using BW=0.35/t rise yields 2.2 GHz)
Analog RGB Coaxial Signals Time Domain Impedance	Risetime = 700 pS (10%-90%) S:G ratio per DVI pin designation Single-ended Measurement Specimen Environment Impedance = 75 ohm single-ended Source-side receptacle connector mounted on a controlled impedance pcb fixture per ANSI/EIA-364-108 Draft Proposal	75 ohms +/-10%
Analog RGB Coaxial Signals Time Domain Crosstalk: (FEXT)	Risetime = 700 pS (10%-90%) S:G ratio per DVI pin designation Single-ended Measurement Specimen Environment Impedance = 75 ohm single-ended Source-side receptacle connector is mounted on a controlled impedance pcb fixture and the load side plug connector is terminated to semi-rigid coax. (1) Driven line and (1) victim line per ANSI/EIA-364-90 Draft Proposal	3% Maximum
Analog RGB Coaxial Signals Rise Time Degradation	S:G ratio per DVI pin designation Single-ended Measurement Specimen Environment Impedance = 75 ohm single-ended Source-side receptacle connector is mounted on a controlled impedance pcb fixture and the load side plug connector is terminated to semi-rigid coax. per ANSI/EIA-364-102	140pS Maximum (Note: Converted bandwidth using BW=0.35/t rise yields 2.5 GHz)

5.2 Mechanical Performance

ITEM	TEST CONDITION	REQUIREMENT
Mating Force	One pair per ANSI/EIA 364-13 Insertion speed: 1inch (25mm) per minute	10.0 lbf (4.5 kgf) maximum
Unmating Force	Mated pair per ANSI/EIA 364-13 Withdraw speed: 1inch (25mm) per minute	2.2 lbf (1.0 kgf) minimum 8.8 lbf (4.0 kgf) maximum
Receptacle Contact Retention	Individual contact	1.0 lbf (0.45 kgf) minimum
Receptacle Key Retention	Individual key	2.0 lbf (0.90 kgf) minimum
Plug Contact Retention	Push out from mating face; Individual contact	10 lbf (4.5 kgf) minimum
Plug Key Retention	Push out from mating face; Individual key	10 lbf (4.5 kgf) minimum

THIS DOCUMENT CONTAINS INFORMATION THAT IS PROPRIETARY TO MOLEX ELECTRONIC TECHNOLOGIES, LLC AND SHOULD NOT BE USED WITHOUT WRITTEN PERMISSION

REVISION DESCRIPTION	REMASTERED			MIROCROSSTM - DVI I/O PLUG AND RECEPTACLE CONNECTOR SYSTEM				
CHANGE NO.	712023							
REVISED BY	MKP	DATE	2022/06/10	DOC TYPE	DOC TYPE DESCRIPTION	DOC PART	SERIES	
REV APPR BY	RLI09	DATE	2022/06/28	PS	ENGINEERING SPECIFICATION WORD	001	74320	
INITIAL RELEASE			CUSTOMER		DOCUMENT NUMBER		REVISION	SHEET
INITIAL DRWN	RFC_PLMIMP	DATE	2020/12/19	GENERAL MARKET		PS-74320-001	J1	7 OF 14
INITIAL APPR	RNELSON	DATE	2000/10/19					

Durability	Automatic cycling: 100 cycles per ANSI/EIA 364-09 at 100 +/- 50 cycles per hour	Contact Resistance per EIA 364-23: 10 milliohm maximum change from initial per contact pair All samples to be mated Shell Resistance: 50 milliohm maximum (change from initial reading)
Vibration	15 minutes / axis per ANSI/EIA 364-28, Method 5A	No discontinuities at 1 microsecond or longer (each contact) when continuity is tested per EIA-364-46
Shock (Mechanical)	Per ANSI/EIA 364-27, Condition A (specified pulse)	No discontinuities at 1 microsecond or longer (each contact) when continuity is tested per EIA-364-46
Cable Pullout Force	Test for cable strain relief & termination integrity. Cable subjected to 25.0 lbf (11.3 kgf) static load for one minute while monitoring continuity. Isolate plug & receptacle interface from load.	No discontinuities greater than 1 microsecond
Board Insertion Force		10.0 lbf (4.5 kgf) maximum
Cable Flex	100 cycles in each of 2 planes Dimension X=3.7x Cable Diameter per ANSI/EIA 364-41, Condition I	No discontinuities greater than 1 microsecond allowed during flexing on contacts or shields per EIA-364-46 Dielectric Withstanding Voltage and Insulation Resistance tested per requirements of section 5.1
Normal Force	For reference only	.050" pitch terminals: 75 grams typical .075" pitch terminals: 90 grams typical Ground Plane: 100 grams typical
Thread Torque	Mounted to panel; Test to failure; Tighten jackposts with torque gage until threads are stripped and jackpost turns freely	5.0 lbf in (5.76 kgf cm) minimum

5.3 Environmental Performance

ITEM	TEST CONDITION	REQUIREMENT
Thermal Shock	10 cycles Mated/Unmated per ANSI/EIA 364-32, Condition I	Contact Resistance: 10 milliohm maximum change from initial per contact pair All samples to be mated Shell Resistance: 50 milliohm maximum change from initial per EIA-364-23
Humidity (Cyclic)	ANSI/EIA 364-31, Conditions A and B Method III, omit 7A and 7B	Contact Resistance: 10 milliohm maximum change from initial per contact pair All samples to be mated Shell Resistance: 50 milliohm maximum change from initial per EIA-364-23
Thermal Aging	105 °C for 250 hours Mated per ANSI/EIA 364-17, Condition 4, Method A.	Contact Resistance: 10 milliohm maximum change from initial per contact pair All samples to be mated Shell Resistance: 50 milliohm maximum change from initial per contact pair per EIA-364-23

THIS DOCUMENT CONTAINS INFORMATION THAT IS PROPRIETARY TO MOLEX ELECTRONIC TECHNOLOGIES, LLC AND SHOULD NOT BE USED WITHOUT WRITTEN PERMISSION

REVISION DESCRIPTION	REMASTERED			MIROCROSSTM - DVI I/O PLUG AND RECEPTACLE CONNECTOR SYSTEM				
CHANGE NO.	712023							
REVISED BY	MKP	DATE	2022/06/10	DOC TYPE	DOC TYPE DESCRIPTION	DOC PART	SERIES	
REV APPR BY	RLI09	DATE	2022/06/28	PS	ENGINEERING SPECIFICATION WORD	001	74320	
INITIAL RELEASE			CUSTOMER		DOCUMENT NUMBER		REVISION	SHEET
INITIAL DRWN	RFC_PLMIMP	DATE	2020/12/19	GENERAL MARKET		PS-74320-001	J1	8 OF 14
INITIAL APPR	RNELSON	DATE	2000/10/19					

Temperature Rise	Per ANSI/EIA 364-70	30 °C maximum temperature rise
Resistance to Solder Heat	Dip connector solder tails to board for 10 seconds Solder Temp = 260 +/- 5 °C	No visual damage to insulator
Solderability	Per MIL-STD-202, Method 208	95% minimum coverage
Temperature Rating	Operating	-20 degree C to +85 degree C
Temperature Rating	Non-Operating	-20 degree C to +85 degree C

6.0 Packaging

6.1 Receptacles:

All receptacles are packaged in trays. For specific packaging information , refer to PK-74320-001 for right angle receptacles and PK-74320-002 for vertical receptacles.

7.0 Other Information

7.1 Test Sequences

THIS DOCUMENT CONTAINS INFORMATION THAT IS PROPRIETARY TO MOLEX ELECTRONIC TECHNOLOGIES, LLC AND SHOULD NOT BE USED WITHOUT WRITTEN PERMISSION

REVISION DESCRIPTION	REMASTERED			MIROCROSSTM - DVI I/O PLUG AND RECEPTACLE CONNECTOR SYSTEM			
CHANGE NO.	712023						
REVISED BY	MKP	DATE	2022/06/10	DOC TYPE	DOC TYPE DESCRIPTION	DOC PART	SERIES
REV APPR BY	RLI09	DATE	2022/06/28	PS	ENGINEERING SPECIFICATION WORD	001	74320
INITIAL RELEASE				CUSTOMER	DOCUMENT NUMBER	REVISION	SHEET
INITIAL DRWN	RFC_PLMIMP	DATE	2020/12/19	GENERAL MARKET	PS-74320-001	J1	9 OF 14
INITIAL APPR	RNELSON	DATE	2000/10/19				

Group 1 : Mated Environmental

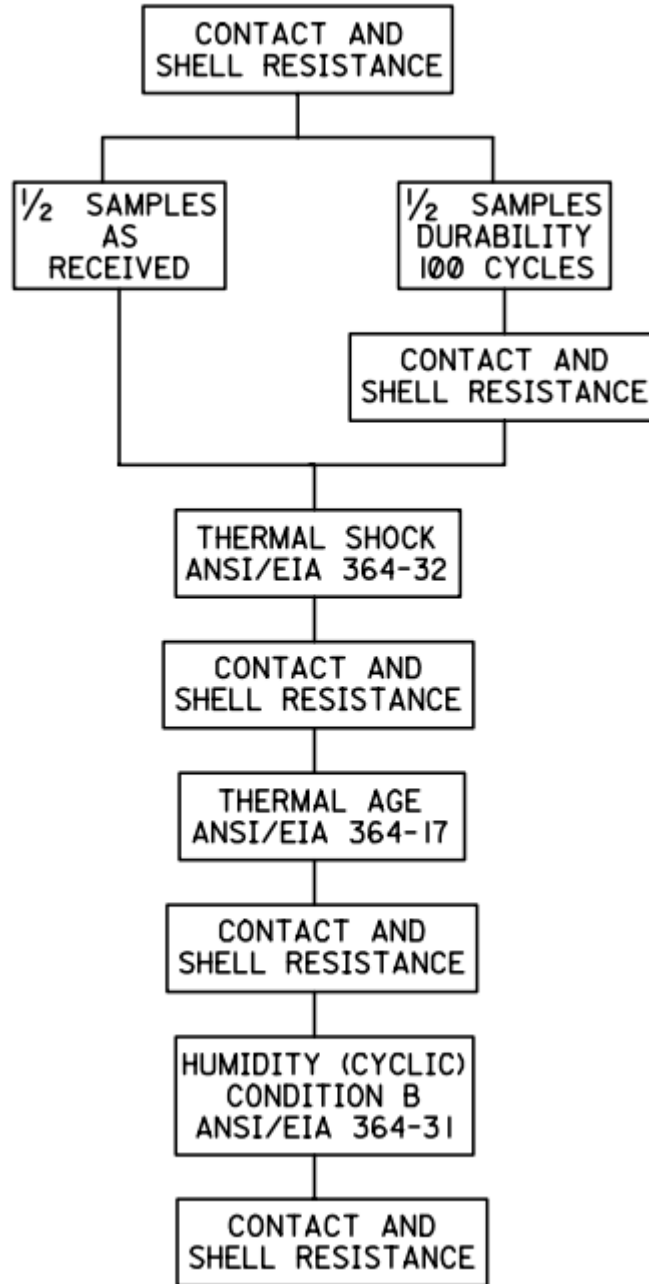

Number of samples

- (5) Receptacle assembled to printed circuit board.
- (5) Cable assemblies with a plug assembled to one end, 10 inch/25.4 cm long

THIS DOCUMENT CONTAINS INFORMATION THAT IS PROPRIETARY TO MOLEX ELECTRONIC TECHNOLOGIES, LLC AND SHOULD NOT BE USED WITHOUT WRITTEN PERMISSION

REVISION DESCRIPTION	REMASTERED			MIROCROSSTM - DVI I/O PLUG AND RECEPTACLE CONNECTOR SYSTEM			
CHANGE NO.	712023			DOC TYPE	DOC TYPE DESCRIPTION	DOC PART	SERIES
REVISED BY	MKP	DATE	2022/06/10	PS	ENGINEERING SPECIFICATION WORD	001	74320
REV APPR BY	RLI09	DATE	2022/06/28	INITIAL RELEASE		CUSTOMER	DOCUMENT NUMBER
INITIAL DRWN	RFC_PLMIMP	DATE	2020/12/19	GENERAL MARKET		REVISION	SHEET
INITIAL APPR	RNELSON	DATE	2000/10/19			J1	10 OF 14
				PS-74320-001			

Group 2: Mated Mechanical

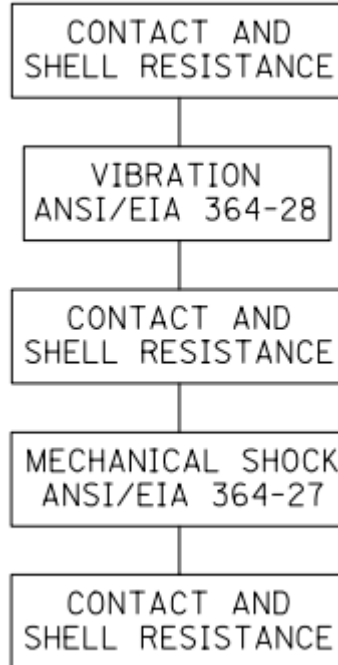

Number of Samples:

- (2) Receptacles, assembled to printed circuit board.
- (2) Cable assemblies with a plug assembled to one end, 10 inch/25.4 cm long.

Note: Connector is to be mounted on a fixture that simulates the typical application. The receptacle connector shall be mounted to a panel, per the receptacle panel cutout shown in Figure 12, which is permanently affixed to the fixture. The plug shall be mated to the receptacle with jackscrews fully engaged and the other end of the cable shall be permanently clamped to the fixture, 3 inches from connector face.

THIS DOCUMENT CONTAINS INFORMATION THAT IS PROPRIETARY TO MOLEX ELECTRONIC TECHNOLOGIES, LLC AND SHOULD NOT BE USED WITHOUT WRITTEN PERMISSION

REVISION DESCRIPTION	REMASTERED			MIROCROSSTM - DVI I/O PLUG AND RECEPTACLE CONNECTOR SYSTEM			
CHANGE NO.	712023			DOC TYPE	DOC TYPE DESCRIPTION	DOC PART	SERIES
REVISED BY	MKP	DATE	2022/06/10	PS	ENGINEERING SPECIFICATION WORD	001	74320
REV APPR BY	RLI09	DATE	2022/06/28	INITIAL RELEASE		REVISION	SHEET
INITIAL DRWN	RFC_PLMIMP	DATE	2020/12/19	CUSTOMER	DOCUMENT NUMBER	J1	11 OF 14
INITIAL APPR	RNELSON	DATE	2000/10/19	GENERAL MARKET	PS-74320-001		

Group 3: Mated Mechanical

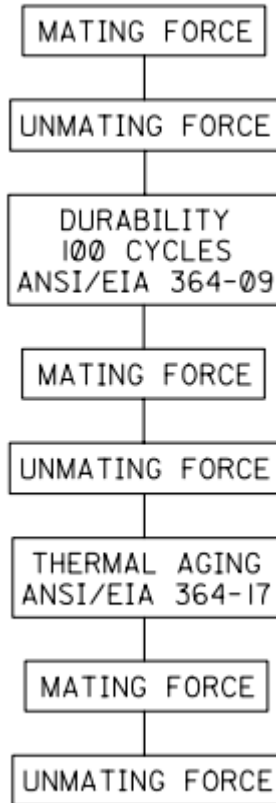

Number of Samples:

- (2) Receptacles, assembled to printed circuit board.
- (2) Cable assemblies with a plug assembled to one end, 10 inch/25.4 cm long.

THIS DOCUMENT CONTAINS INFORMATION THAT IS PROPRIETARY TO MOLEX ELECTRONIC TECHNOLOGIES, LLC AND SHOULD NOT BE USED WITHOUT WRITTEN PERMISSION

REVISION DESCRIPTION	REMASTERED			MIROCROSSTM - DVI I/O PLUG AND RECEPTACLE CONNECTOR SYSTEM			
CHANGE NO.	712023			DOC TYPE	DOC TYPE DESCRIPTION	DOC PART	SERIES
REVISED BY	MKP	DATE	2022/06/10	PS	ENGINEERING SPECIFICATION WORD	001	74320
REV APPR BY	RLI09	DATE	2022/06/28	INITIAL RELEASE		REVISION	SHEET
INITIAL DRWN	RFC_PLMIMP	DATE	2020/12/19	CUSTOMER	DOCUMENT NUMBER	J1	12 OF 14
INITIAL APPR	RNELSON	DATE	2000/10/19	GENERAL MARKET	PS-74320-001		

Group 4: Insulator Integrity

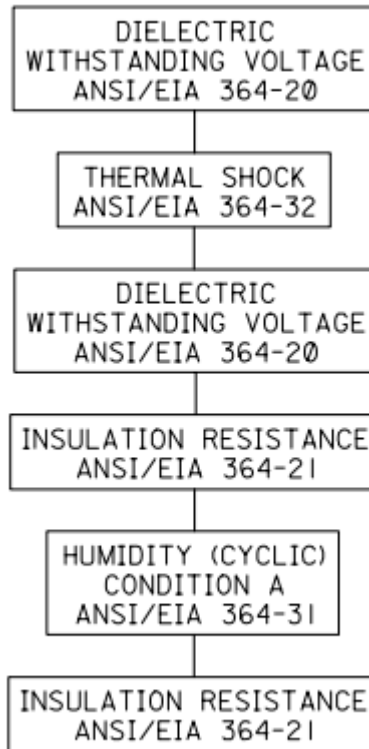

Number of Samples:

- (2) Receptacles, assembled to printed circuit board.
- (2) Cable assemblies with a plug assembled to one end, 10 inch/25.4 cm long

Group 5: Cable Flexing

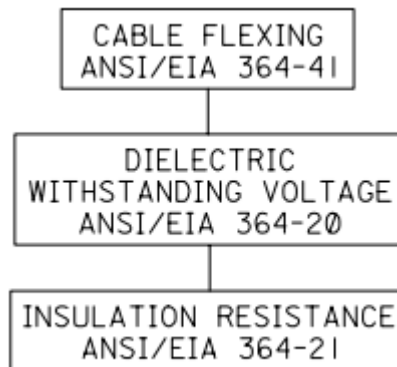

Number of Samples:

- (2) Cable assemblies

THIS DOCUMENT CONTAINS INFORMATION THAT IS PROPRIETARY TO MOLEX ELECTRONIC TECHNOLOGIES, LLC AND SHOULD NOT BE USED WITHOUT WRITTEN PERMISSION

REVISION DESCRIPTION	REMASTERED			MIROCROSSTM - DVI I/O PLUG AND RECEPTACLE CONNECTOR SYSTEM			
CHANGE NO.	712023			DOC TYPE	DOC TYPE DESCRIPTION	DOC PART	SERIES
REVISED BY	MKP	DATE	2022/06/10	PS	ENGINEERING SPECIFICATION WORD	001	74320
REV APPR BY	RLI09	DATE	2022/06/28	INITIAL RELEASE		REVISION	SHEET
INITIAL DRWN	RFC_PLMIMP	DATE	2020/12/19	CUSTOMER	DOCUMENT NUMBER	J1	13 OF 14
INITIAL APPR	RNELSON	DATE	2000/10/19	GENERAL MARKET	PS-74320-001		

Group 6: Electrostatic Discharge

<p>ELECTROSTATIC DISCHARGE</p>

Number of Samples:

(1) Receptacle connector

THIS DOCUMENT CONTAINS INFORMATION THAT IS PROPRIETARY TO MOLEX ELECTRONIC TECHNOLOGIES, LLC AND SHOULD NOT BE USED WITHOUT WRITTEN PERMISSION

REVISION DESCRIPTION	REMASTERED			MIROCROSSTM - DVI I/O PLUG AND RECEPTACLE CONNECTOR SYSTEM			
CHANGE NO.	712023						
REVISED BY	MKP	DATE	2022/06/10	DOC TYPE	DOC TYPE DESCRIPTION	DOC PART	SERIES
REV APPR BY	RLI09	DATE	2022/06/28	PS	ENGINEERING SPECIFICATION WORD	001	74320
INITIAL RELEASE				CUSTOMER	DOCUMENT NUMBER	REVISION	SHEET
INITIAL DRWN	RFC_PLMIMP	DATE	2020/12/19	GENERAL MARKET	PS-74320-001	J1	14 OF 14
INITIAL APPR	RNELSON	DATE	2000/10/19				