

4-Pin DIP Photodarlington Output Optocoupler

FOD852

Description

The FOD852 consists of gallium arsenide infrared emitting diode driving a silicon photodarlington output (with integral base-emitter resistor) in a 4-pin dual in-line package.

Features

- High Current Transfer Ratio: 1000% Minimum
- Safety and Regulatory Approvals
 - ◆ UL1577; 5,000 VAC_{RMS} for 1 Minute
 - ◆ DIN EN/IEC60747-5-5
- These are Pb-Free Devices

Applications

- Power Supply Regulators
- Digital Logic Inputs
- Microprocessor Inputs

Functional Block Diagram

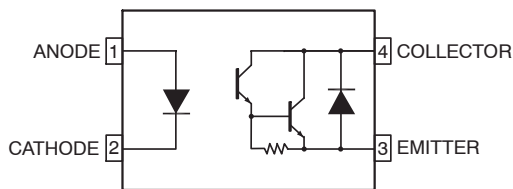
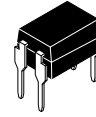
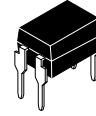

Figure 1. Schematic



PDIP4 4.6x6.5, 2.54P
CASE 646CA



PDIP4 4.6x6.5, 2.54P
CASE 646CD

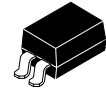

PDIP4 4.60x6.50x3.85, 2.54P
CASE 709AH

MARKING DIAGRAM

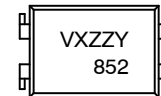

- V = DIN EN/IEC60747-5-5 Option (only appears on parts ordered with this option)
- X = One Digit Year Code
- ZZ = Two Digit Work Week
- Y = Assembly Package Code
- 852 = Specific Device Code

ORDERING INFORMATION

See detailed ordering and shipping information on page 8 of this data sheet.

SAFETY AND INSULATION RATINGS

As per DIN EN/IEC 60747-5-5, this optocoupler is suitable for “safe electrical insulation” only within the safety limit data. Compliance with the safety ratings shall be ensured by means of protective circuits.

Parameter		Characteristics
Installation Classifications per DIN VDE 0110/1.89 Table 1, For Rated Mains Voltage	< 150 V _{RMS}	I-IV
	< 300 V _{RMS}	I-III
Climatic Classification		30/110/21
Pollution Degree (DIN VDE 0110/1.89)		2
Comparative Tracking Index		175

Symbol	Parameter	Value	Unit
V _{PR}	Input-to-Output Test Voltage, Method A, V _{IORM} × 1.6 = V _{PR} , Type and Sample Test with t _m = 10 s, Partial Discharge < 5 pC	1360	V _{peak}
	Input-to-Output Test Voltage, Method B, V _{IORM} × 1.875 = V _{PR} , 100% Production Test with t _m = 1 s, Partial Discharge < 5 pC	1560	V _{peak}
V _{IORM}	Maximum Working Insulation Voltage	850	V _{peak}
V _{IOTM}	Highest Allowable Over-Voltage	6000	V _{peak}
	External Creepage	≥7	mm
	External Clearance	≥7	mm
DTI	Distance Through Insulation (Insulation Thickness)	≥0.4	mm
T _S	Case Temperature (Note 1)	175	°C
I _{S, INPUT}	Input Current (Note 1)	400	mA
P _{S, OUTPUT}	Output Power (Note 1)	700	mW
R _{IO}	Insulation Resistance at T _S , V _{IO} = 500 V (Note 1)	>10 ¹¹	Ω

1. Safety limit values – maximum values allowed in the event of a failure.

MAXIMUM RATINGS (T_A = 25 °C unless otherwise noted)

Symbol	Rating	Value	Unit
--------	--------	-------	------

TOTAL DEVICE

T _{STG}	Storage Temperature	-55 to +125	°C
T _{OPR}	Operating Temperature	-30 to +100	°C
T _J	Junction Temperature	-55 to +100	°C
T _{SOL}	Lead Solder Temperature	260 for 10 seconds	°C
P _{TOT}	Total Device Power Dissipation	200	mW

INPUT

I _F	Continuous Forward Current	50	mA
V _R	Reverse Voltage	6	V
P _D	LED Power Dissipation	70	mW

OUTPUT

V _{CEO}	Collector-Emitter Voltage	300	V
V _{ECO}	Emitter-Collector Voltage	0.1	V
I _C	Continuous Collector Current	150	mA
P _C	Collector Power Dissipation	150	mW

Stresses exceeding those listed in the Maximum Ratings table may damage the device. If any of these limits are exceeded, device functionality should not be assumed, damage may occur and reliability may be affected.

FOD852

ELECTRICAL CHARACTERISTICS

(T_A = 25 °C unless otherwise noted)

INDIVIDUAL COMPONENT CHARACTERISTICS

Symbol	Parameter	Test Condition	Min	Typ	Max	Unit
INPUT						
V _F	Forward Voltage	I _F = 10 mA	–	1.2	1.4	V
I _R	Reverse Current	V _R = 4 V	–	–	10	μA
C _t	Terminal Capacitance	V = 0, f = 1 kHz	–	30	250	pF
OUTPUT						
I _{CEO}	Collector Dark Current	V _{CE} = 200, I _F = 0	–	–	200	nA
BV _{CEO}	Collector-Emitter Breakdown Voltage	I _C = 0.1 mA, I _F = 0	300	–	–	V
BV _{ECO}	Emitter-Collector Breakdown Voltage	I _E = 10 μA, I _F = 0	0.1	–	–	V

TRANSFER CHARACTERISTICS

Symbol	DC Characteristics	Test Condition	Min	Typ	Max	Unit
I _C	Collector Current	I _F = 1 mA, V _{CE} = 2 V	10	40	150	mA
CTR	Current Transfer Ratio (Note 2)		1,000	4,000	15,000	%
V _{CE(SAT)}	Collector-Emitter Saturation Voltage	I _F = 20 mA, I _C = 100 mA	–	–	1.2	V
f _C	Cut-Off Frequency	V _{CE} = 2 V, I _C = 20 mA, R _L = 100 Ω, –3 dB	1	7	–	kHz
t _R	Response Time (Rise)	V _{CE} = 2 V, I _C = 20 mA, R _L = 100 Ω	–	100	300	μs
t _F	Response Time (Fall)		–	20	100	μs

2. Current Transfer Ratio (CTR) = I_C / I_F x 100%.

ISOLATION CHARACTERISTICS

Symbol	Characteristics	Test Condition	Min	Typ	Max	Unit
V _{ISO}	Input-Output Isolation Voltage	f = 60 Hz, t = 1 minute, I _{I-O} ≤ 2 μA	5000	–	–	V _{AC(RMS)}
R _{ISO}	Isolation Resistance	V _{I-O} = 500 V dc	–	10 ¹²	–	Ω
C _{ISO}	Isolation Capacitance	V _{I-O} = 0, f = 1 MHz	–	0.6	1.0	pf

Product parametric performance is indicated in the Electrical Characteristics for the listed test conditions, unless otherwise noted. Product performance may not be indicated by the Electrical Characteristics if operated under different conditions.

TYPICAL ELECTRICAL/OPTICAL CHARACTERISTIC CURVES ($T_A = 25^\circ\text{C}$ unless otherwise noted)

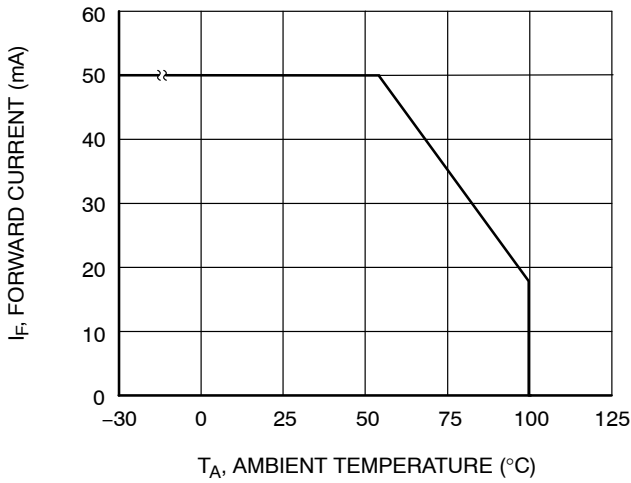

Figure 2. Forward Current vs. Ambient Temperature

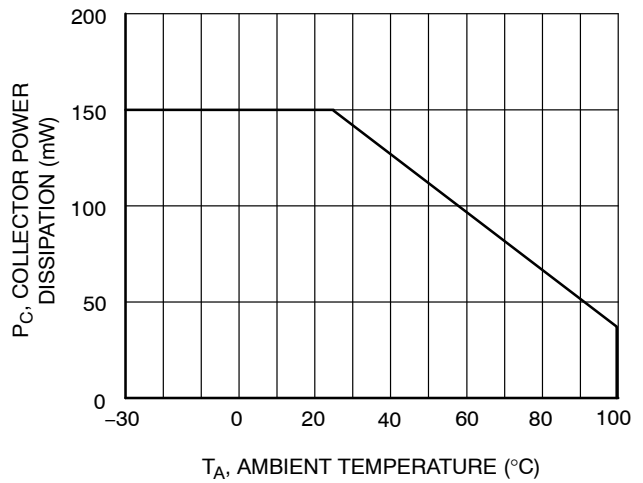

Figure 3. Collector Power Dissipation vs. Ambient Temperature

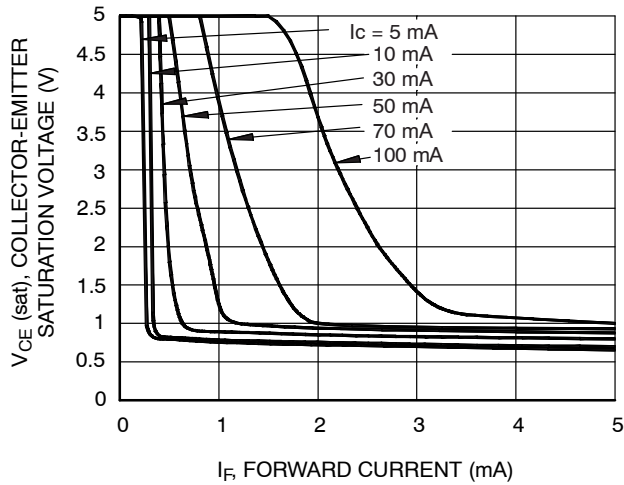

Figure 4. Collector-Emitted Saturation Voltage vs. Forward Current

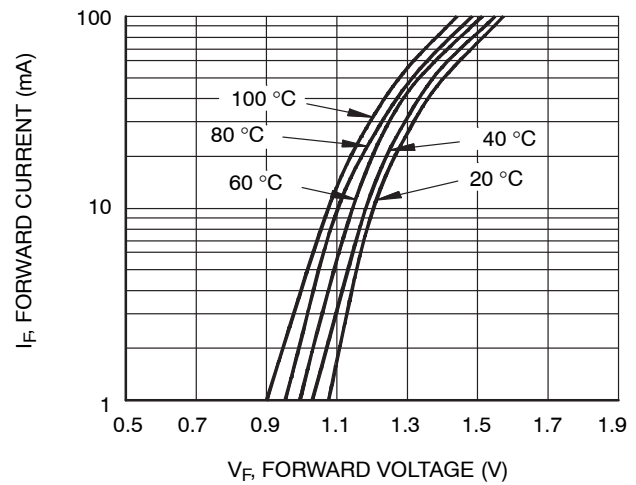

Figure 5. Forward Current vs. Forward Voltage

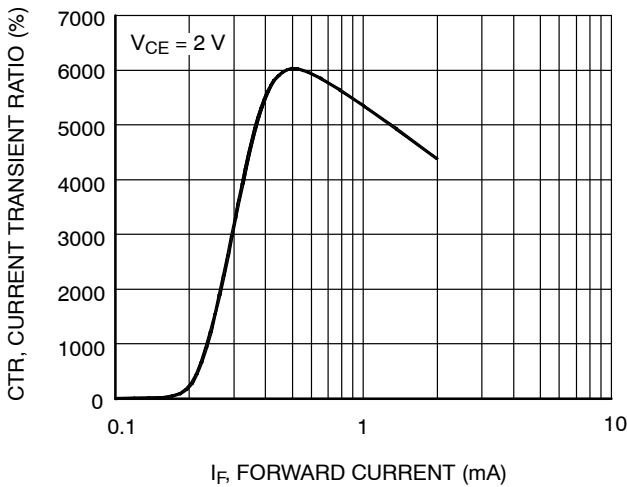

Figure 6. Current Transfer Ratio vs. Forward Current

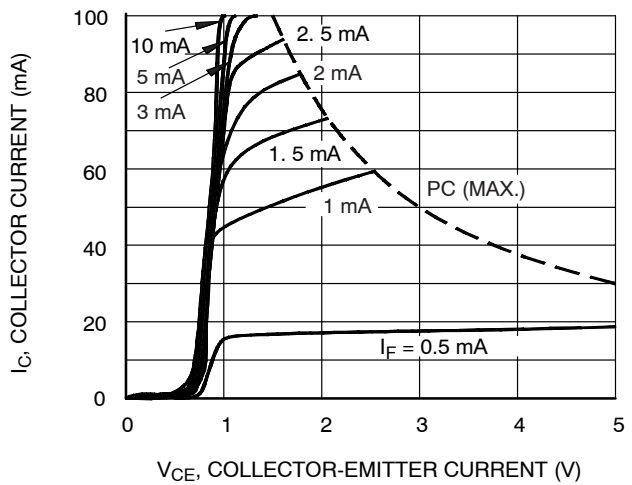

Figure 7. Collector Current vs. Collector-Emitter Voltage

TYPICAL ELECTRICAL/OPTICAL CHARACTERISTIC CURVES ($T_A = 25\text{ }^\circ\text{C}$ unless otherwise noted) (continued)

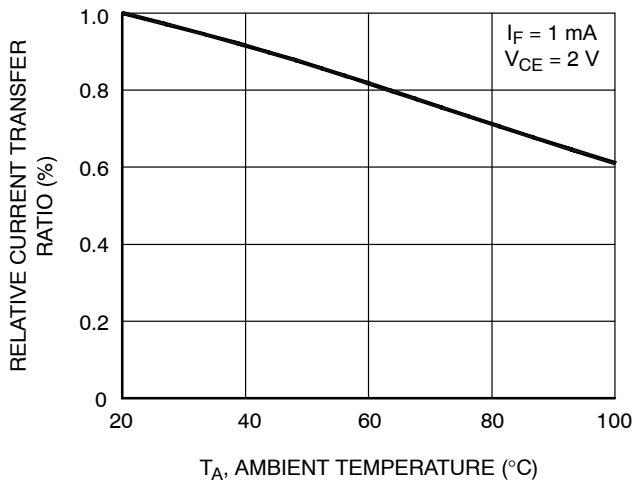

Figure 8. Relative Current Transfer Ratio vs. Ambient Temperature

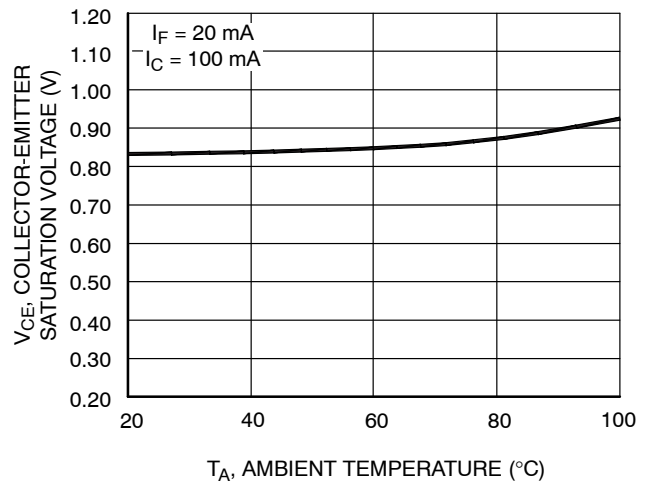

Figure 9. Collector-Emitter Saturation Voltage vs. Ambient Temperature

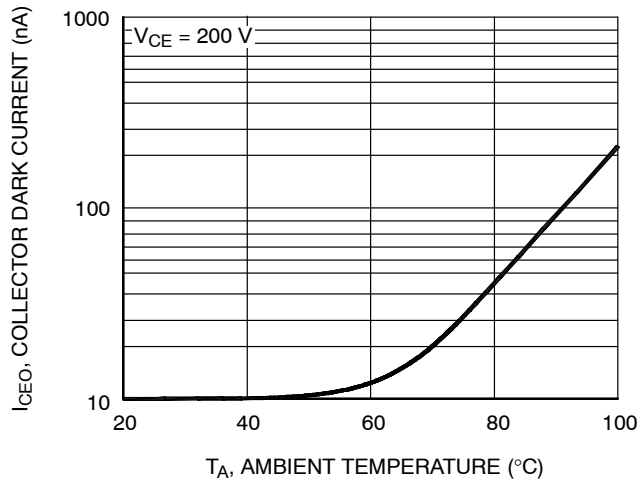

Figure 10. Collector Dark Current vs. Ambient Temperature

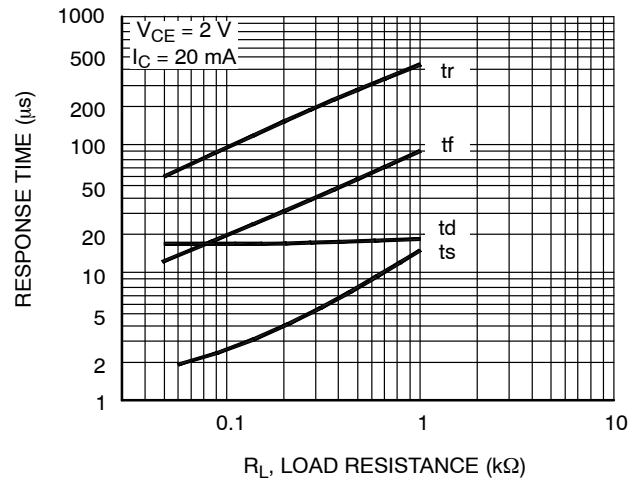

Figure 11. Response Time vs. Load Resistance

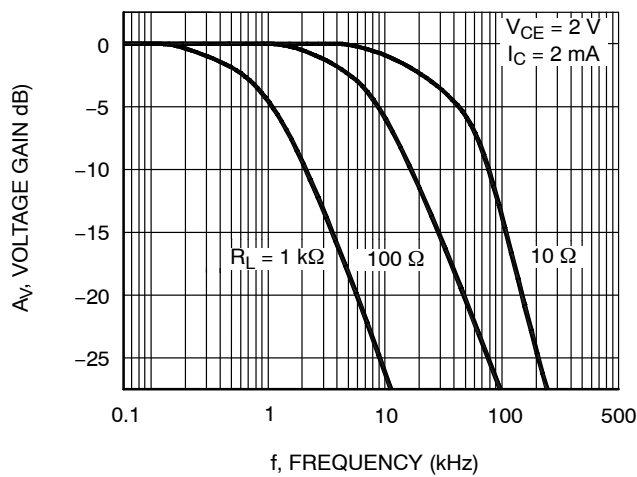

Figure 12. Frequency Response

FOD852

TEST CIRCUITS

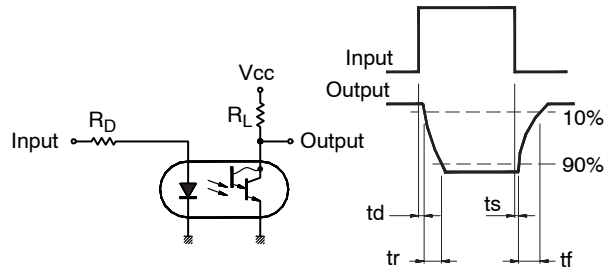

Figure 13. Test Circuit for Response Time

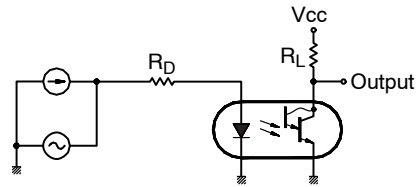
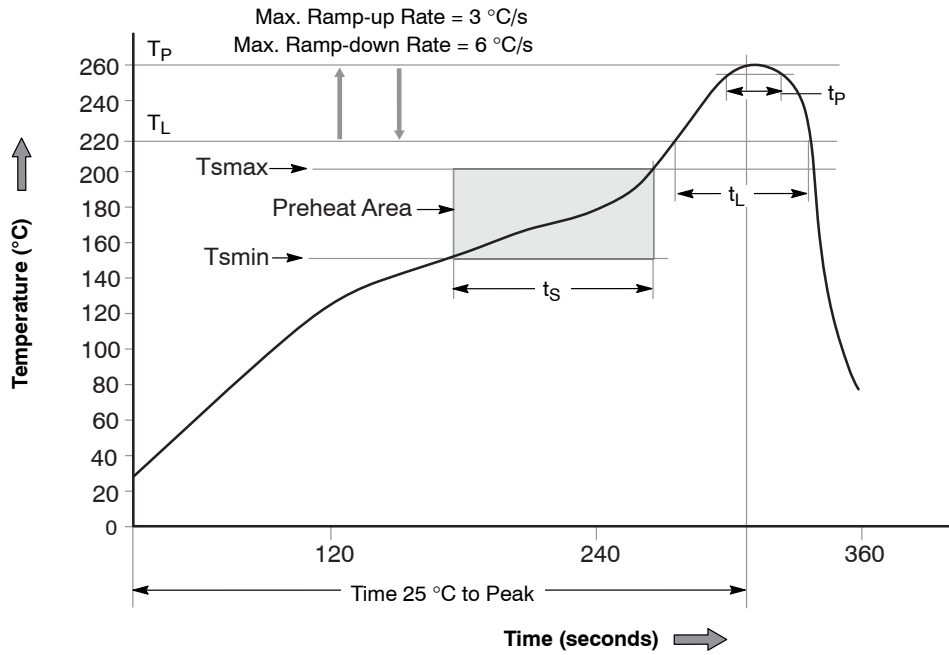

Figure 14. Test Circuit for Frequency Response

REFLOW PROFILE



Profile Feature	Pb-Free Assembly Profile
Temperature Min. (Tsmín)	150 °C
Temperature Max. (Tsmín)	200 °C
Time (ts) from)Tsmín to Tsmáx	60–120 seconds
Ramp-up Rate (tL to tp)	3 °C/seconds max.
Liquidous Temperature (TL)	217 °C
Time (tL) Maintained Above (TL)	60–150 seconds
Peak Body Package Temperature	260 °C +0 °C / -5 °C
Time (tp) within 5 °C of 260 °C	30 seconds
Ramp-down Rate (TP to TL)	6 °C / seconds max.
Time 25 °C to Peak Temperature	8 minutes max.

Figure 15. Reflow Profile

FOD852

ORDERING INFORMATION

Part Number	Package Type	Shipping†
FOD852	DIP 4-Pin (Case 646CD)	2000 / Unit Box
FOD852S	SMT 4-Pin (Lead Bend) (Case 709AH)	2000 / Unit Box
FOD852SD	SMT 4-Pin (Lead Bend) (Case 709AH)	1000 / Tape & Reel
FOD852300	DIP 4-Pin, DIN EN/IEC60747-5-5 option (Case 646CD)	2000 / Unit Box
FOD8523S	SMT 4-Pin (Lead Bend), DIN EN/IEC60747-5-5 option (Case 709AH)	2000 / Unit Box
FOD8523SD	SMT 4-Pin (Lead Bend), DIN EN/IEC60747-5-5 option (Case 709AH)	1000 / Tape & Reel
FOD852300W	DIP 4-Pin, 0.4" Lead Spacing, DIN EN/IEC60747-5-5 option (Case 646CA)	2000 / Unit Box

†For information on tape and reel specifications, including part orientation and tape sizes, please refer to our Tape and Reel Packaging Specifications Brochure, [BRD8011/D](#).



PDIP4 4.6x6.5, 2.54P
CASE 646CA
ISSUE O

DATE 31 JUL 2016

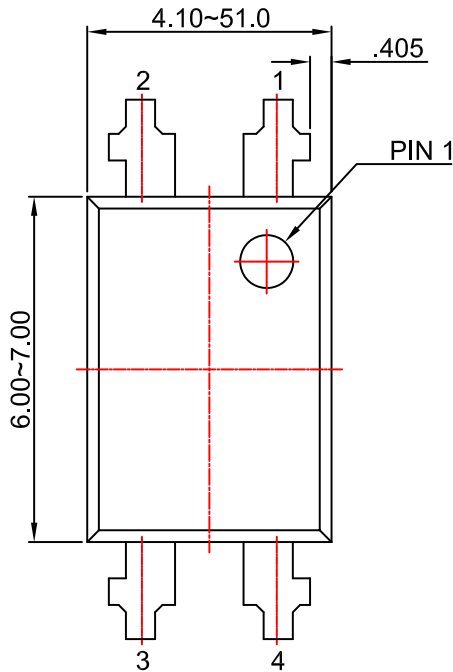

NOTES:

- A) NO STANDARD APPLIES TO THIS PACKAGE.
- B) ALL DIMENSIONS ARE IN MILLIMETERS.
- C) DIMENSIONS ARE EXCLUSIVE OF BURRS, MOLD FLASH, AND TIE BAR EXTRUSION

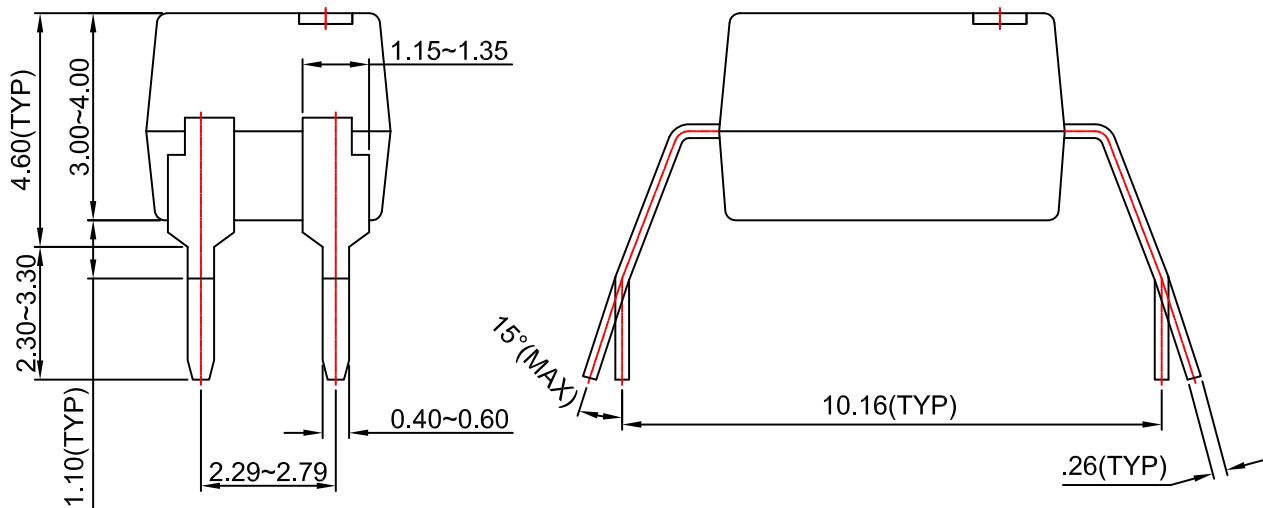

DOCUMENT NUMBER:	98AON13453G	Electronic versions are uncontrolled except when accessed directly from the Document Repository. Printed versions are uncontrolled except when stamped "CONTROLLED COPY" in red.
DESCRIPTION:	PDIP4 4.6X6.5, 2.54P	PAGE 1 OF 1

onsemi and ONSEMI are trademarks of Semiconductor Components Industries, LLC dba onsemi or its subsidiaries in the United States and/or other countries. onsemi reserves the right to make changes without further notice to any products herein. onsemi makes no warranty, representation or guarantee regarding the suitability of its products for any particular purpose, nor does onsemi assume any liability arising out of the application or use of any product or circuit, and specifically disclaims any and all liability, including without limitation special, consequential or incidental damages. onsemi does not convey any license under its patent rights nor the rights of others.

PDIP4 4.6x6.5, 2.54P
CASE 646CD
ISSUE O

DATE 31 JUL 2016

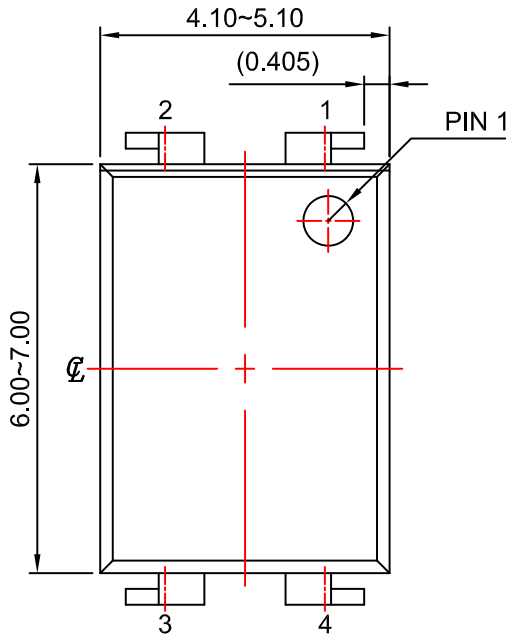

NOTES:

- A) NO STANDARD APPLIES TO THIS PACKAGE.
- B) ALL DIMENSIONS ARE IN MILLIMETERS.
- C) DIMENSIONS ARE EXCLUSIVE OF BURRS, MOLD FLASH, AND TIE BAR EXTRUSION

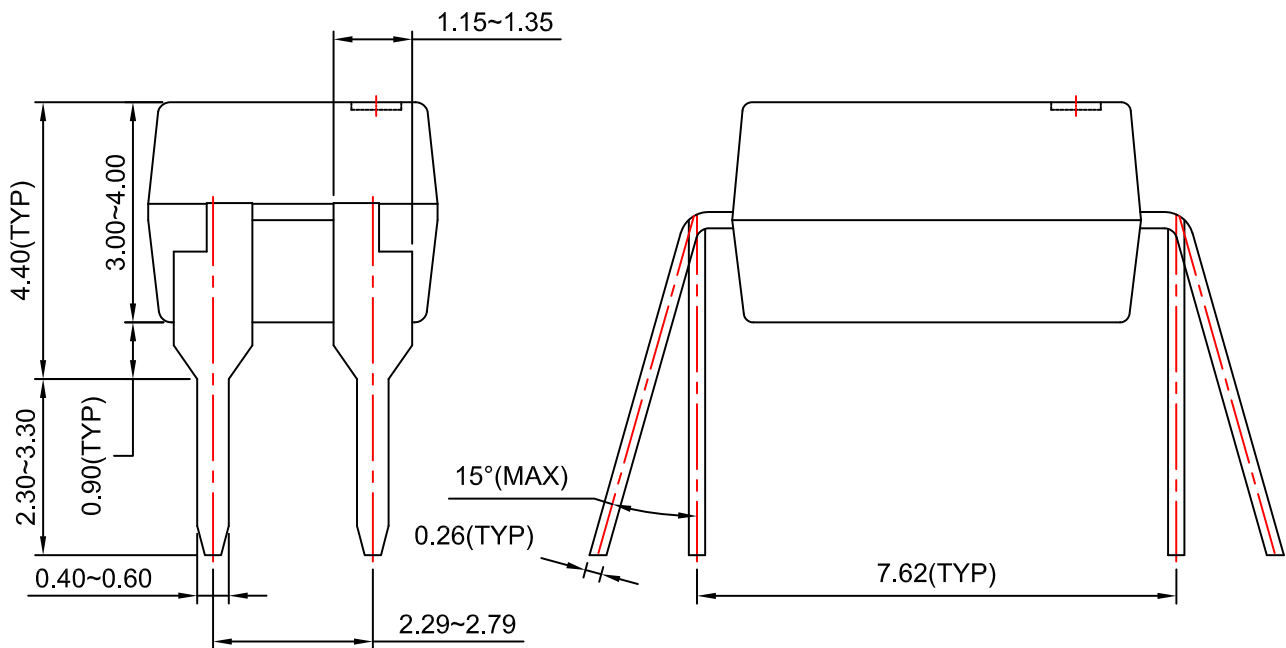

DOCUMENT NUMBER:	98AON13452G	Electronic versions are uncontrolled except when accessed directly from the Document Repository. Printed versions are uncontrolled except when stamped "CONTROLLED COPY" in red.
DESCRIPTION:	PDIP4 4.6X6.5, 2.54P	PAGE 1 OF 1

onsemi and ONSEMI are trademarks of Semiconductor Components Industries, LLC dba onsemi or its subsidiaries in the United States and/or other countries. onsemi reserves the right to make changes without further notice to any products herein. onsemi makes no warranty, representation or guarantee regarding the suitability of its products for any particular purpose, nor does onsemi assume any liability arising out of the application or use of any product or circuit, and specifically disclaims any and all liability, including without limitation special, consequential or incidental damages. onsemi does not convey any license under its patent rights nor the rights of others.

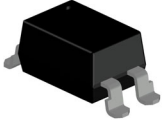

PDIP4 4.60x6.50x3.85, 2.54P
CASE 709AH
ISSUE B

DATE 06 JUL 2023

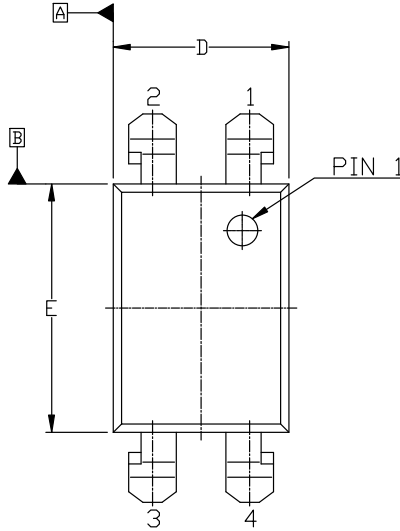

TOP VIEW

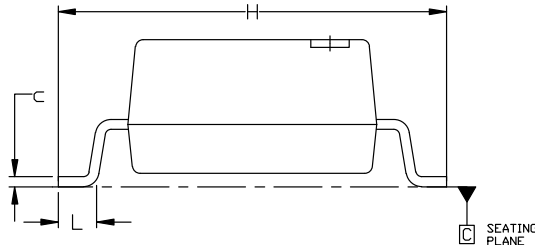

END VIEW

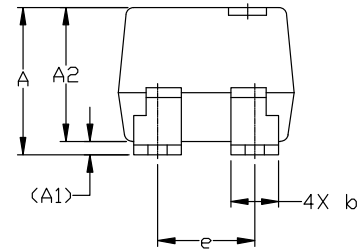

SIDE VIEW

NOTES:

1. DIMENSIONING AND TOLERANCING PER ASME Y14.5M, 1994.
2. CONTROLLING DIMENSION: MILLIMETERS.
3. DIMENSIONS ARE EXCLUSIVE OF BURRS, MOLD FLASH, AND TIE BAR EXTRUSION.
4. DRAWING FILENAME AND REVISION: MKT-N04Crev2.

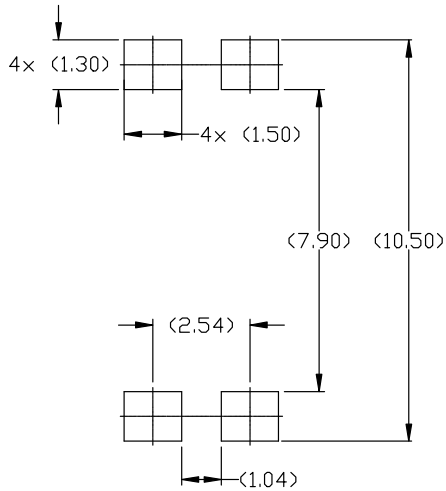

LAND PATTERN RECOMMENDATION

DIM	MILLIMETERS		
	MIN.	NOM.	MAX.
A	3.85 (TYP)		
A1	0.35 (REF)		
A2	3.00	3.50	4.00
b	1.15	1.25	1.35
c	0.26 (REF)		
D	4.10	4.60	5.10
E	6.00	6.50	7.00
e	2.29	2.54	2.79
H	9.86	10.16	10.46
L	0.75	---	1.25

* For additional information on our Pb-Free strategy and soldering details, please download the ON Semiconductor Soldering and Mounting Techniques Reference Manual, SOLDERM/D.

DOCUMENT NUMBER:	98AON13454G	Electronic versions are uncontrolled except when accessed directly from the Document Repository. Printed versions are uncontrolled except when stamped "CONTROLLED COPY" in red.
DESCRIPTION:	PDIP4 4.60x6.50x3.85, 2.54P	PAGE 1 OF 1

onsemi and ONSEMI are trademarks of Semiconductor Components Industries, LLC dba onsemi or its subsidiaries in the United States and/or other countries. onsemi reserves the right to make changes without further notice to any products herein. onsemi makes no warranty, representation or guarantee regarding the suitability of its products for any particular purpose, nor does onsemi assume any liability arising out of the application or use of any product or circuit, and specifically disclaims any and all liability, including without limitation special, consequential or incidental damages. onsemi does not convey any license under its patent rights nor the rights of others.

onsemi, **Onsemi**, and other names, marks, and brands are registered and/or common law trademarks of Semiconductor Components Industries, LLC dba "**onsemi**" or its affiliates and/or subsidiaries in the United States and/or other countries. **onsemi** owns the rights to a number of patents, trademarks, copyrights, trade secrets, and other intellectual property. A listing of **onsemi**'s product/patent coverage may be accessed at www.onsemi.com/site/pdf/Patent-Marking.pdf. **onsemi** reserves the right to make changes at any time to any products or information herein, without notice. The information herein is provided "as-is" and **onsemi** makes no warranty, representation or guarantee regarding the accuracy of the information, product features, availability, functionality, or suitability of its products for any particular purpose, nor does **onsemi** assume any liability arising out of the application or use of any product or circuit, and specifically disclaims any and all liability, including without limitation special, consequential or incidental damages. Buyer is responsible for its products and applications using **onsemi** products, including compliance with all laws, regulations and safety requirements or standards, regardless of any support or applications information provided by **onsemi**. "Typical" parameters which may be provided in **onsemi** data sheets and/or specifications can and do vary in different applications and actual performance may vary over time. All operating parameters, including "Typicals" must be validated for each customer application by customer's technical experts. **onsemi** does not convey any license under any of its intellectual property rights nor the rights of others. **onsemi** products are not designed, intended, or authorized for use as a critical component in life support systems or any FDA Class 3 medical devices or medical devices with a same or similar classification in a foreign jurisdiction or any devices intended for implantation in the human body. Should Buyer purchase or use **onsemi** products for any such unintended or unauthorized application, Buyer shall indemnify and hold **onsemi** and its officers, employees, subsidiaries, affiliates, and distributors harmless against all claims, costs, damages, and expenses, and reasonable attorney fees arising out of, directly or indirectly, any claim of personal injury or death associated with such unintended or unauthorized use, even if such claim alleges that **onsemi** was negligent regarding the design or manufacture of the part. **onsemi** is an Equal Opportunity/Affirmative Action Employer. This literature is subject to all applicable copyright laws and is not for resale in any manner.

ADDITIONAL INFORMATION

TECHNICAL PUBLICATIONS:

Technical Library: www.onsemi.com/design/resources/technical-documentation
onsemi Website: www.onsemi.com

ONLINE SUPPORT: www.onsemi.com/support

For additional information, please contact your local Sales Representative at www.onsemi.com/support/sales