

# High Speed-10 MBit/s Logic Gate Optocouplers

**Single Channel:**

HCPL0600, HCPL0601, HCPL0611

**Dual Channel:**

HCPL0637, HCPL0638, HCPL0639

## HCPL0600, HCPL0601, HCPL0611, HCPL0637, HCPL0638, HCPL0639

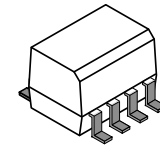

SOIC8  
CASE 751DZ

### MARKING DIAGRAM

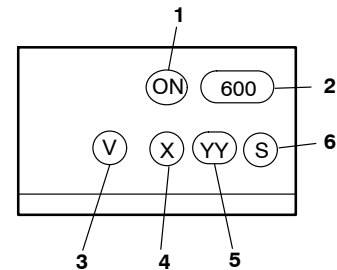

1. ON = **onsemi** Logo
2. 600 = Device Number
3. V = VDE mark indicates DIN EN/IEC60747-5-2 approval (Note: Only appears on parts ordered with VDE option – See Ordering Information Table)
4. X = One-Digit Year Code, e.g. '3'
5. YY = Two Digit Work Week Ranging from '01' to '53'
6. S = Assembly Package Code

### Description

The HCPL06XX optocouplers consist of an AlGaAS LED, optically coupled to a very high speed integrated photo-detector logic gate with a strobable output (single channel devices). The devices are housed in a compact small-outline package. This output features an open collector, thereby permitting wired OR outputs. The HCPL0600, HCPL0601 and HCPL0611 output consists of bipolar transistors on a bipolar process while the HCPL0637, HCPL0638, and HCPL0639 output consists of bipolar transistors on a CMOS process for reduced power consumption. The coupled parameters are guaranteed over the temperature range of  $-40^{\circ}\text{C}$  to  $+85^{\circ}\text{C}$ . An internal noise shield provides superior common mode rejection.

### Features

- Compact SO8 Package
- Very High Speed-10 MBit/s
- Superior CMR
- Logic Gate Output
- Storable Output (Single Channel Devices)
- Wired OR-open Collector

### Safety and Regulatory Approvals

- UL1577, 3750 VAC<sub>RMS</sub> for 1 min
- DIN EN/IEC60747-5-5, 565 V Peak Working Insulation Voltage

### Typical Applications

- Ground Loop Elimination
- LSTTL to TTL, LSTTL or 5-volt CMOS
- Line Receiver, Data Transmission
- Data Multiplexing
- Switching Power Supplies
- Pulse Transformer Replacement
- Computer-peripheral Interface

### ORDERING INFORMATION

See detailed ordering and shipping information on page 13 of this data sheet.

# HCPL0600, HCPL0601, HCPL0611, HCPL0637, HCPL0638, HCPL0639

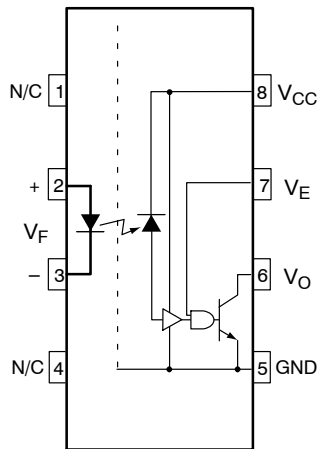

**Figure 1. Single-channel Circuit Drawing (HCPL0600, HCPL0601 and HCPL0611)**

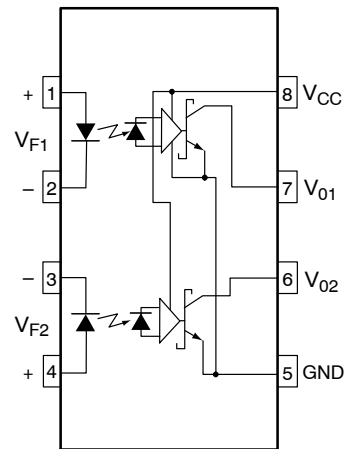

**Figure 2. Dual-channel Circuit Drawing (HCPL0637, HCPL0638 and HCPL0639)**

## TRUTH TABLE (Positive Logic)

Input	Enable	Output
H	H	L
L	H	H
H	L	H
L	L	H
H*	NC*	L*
L*	NC*	H*

\*Dual channel devices or single channel devices with pin 7 not connected. A 0.1  $\mu$ F bypass capacitor must be connected between pins 8 and 5. (See Note 2)

# HCPL0600, HCPL0601, HCPL0611, HCPL0637, HCPL0638, HCPL0639

## SAFETY AND INSULATIONS RATING

As per DIN EN/IEC 60747-5-5, this optocoupler is suitable for "safe electrical insulation" only within the safety limit data. Compliance with the safety ratings shall be ensured by means of protective circuits.

Parameter		Characteristics
Installation Classifications per DIN VDE 0110/1.89 Table 1, For Rated Mains Voltage	< 150 V <sub>RMS</sub>	I-IV
	< 300 V <sub>RMS</sub>	I-III
Climatic Classification		40/85/21
Pollution Degree (DIN VDE 0110/1.89)		2
Comparative Tracking Index		175

Symbol	Parameter	Value	Unit
V <sub>PR</sub>	Input-to-Output Test Voltage, Method A, V <sub>IORM</sub> × 1.6 = V <sub>PR</sub> , Type and Sample Test with t <sub>m</sub> = 10 s, Partial Discharge < 5 pC	904	V <sub>peak</sub>
	Input-to-Output Test Voltage, Method B, V <sub>IORM</sub> × 1.875 = V <sub>PR</sub> , 100% Production Test with t <sub>m</sub> = 1 s, Partial Discharge < 5 pC	1060	V <sub>peak</sub>
V <sub>IORM</sub>	Maximum Working Insulation Voltage	565	V <sub>peak</sub>
V <sub>IOTM</sub>	Highest Allowable Over-Voltage	4,000	V <sub>peak</sub>
	External Creepage	≥ 4	mm
	External Clearance	≥ 4	mm
DTI	Distance Through Insulation (Insulation Thickness)	≥ 0.4	mm
T <sub>S</sub>	Case Temperature (Note 1)	150	°C
I <sub>S,INPUT</sub>	Input Current (Note 1)	200	mA
P <sub>S,OUTPUT</sub>	Output Power (Note 1)	300	mW
R <sub>IO</sub>	Insulation Resistance at T <sub>S</sub> , V <sub>IO</sub> = 500 V (Note 1)	> 10 <sup>9</sup>	Ω

1. Safety limit values – maximum values allowed in the event of a failure.

## ABSOLUTE MAXIMUM RATINGS (No Derating Required up to 85°C)

Symbol	Parameter	Value	Units
T <sub>STG</sub>	Storage Temperature	-40 to +125	°C
T <sub>OPR</sub>	Operating Temperature	-40 to +85	°C
T <sub>J</sub>	Junction Temperature	-40 to +125	°C

### EMITTER

I <sub>F</sub>	DC/Average Forward Input Current	Each Channel	50	mA
V <sub>E</sub>	Enable Input Voltage Not to exceed VCC by more than 500 mV	Single Channel Devices Only	5.5	V
V <sub>R</sub>	Reverse Input Voltage	Each Channel	5.0	V
P <sub>I</sub>	Power Dissipation	Each Channel	45	mW

### DETECTOR

V <sub>CC</sub> (1 minute max)	Supply Voltage		7.0	V
I <sub>O</sub>	Output Current	Each Channel	15	mA
V <sub>O</sub>	Output Voltage (each channel)	Each Channel	7.0	V
P <sub>O</sub>	Collector Output Power Dissipation	Each Channel	85	mW

Stresses exceeding those listed in the Maximum Ratings table may damage the device. If any of these limits are exceeded, device functionality should not be assumed, damage may occur and reliability may be affected.

# HCPL0600, HCPL0601, HCPL0611, HCPL0637, HCPL0638, HCPL0639

## RECOMMENDED OPERATING CONDITIONS

Symbol	Parameter		Min.	Max.	Units
$I_{FL}$	Input Current, Low Level		0	250	$\mu$ A
$I_{FH}$	Input Current, High Level		*6.3	15	mA
$V_{CC}$	Supply Voltage, Output		4.5	5.5	V
$V_{EL}$	Enable Voltage, Low Level	Single Channel only	0	0.8	V
$V_{EH}$	Enable Voltage, High Level	Single Channel only	2.0	$V_{CC}$	V
$T_A$	Operating Temperature		-40	+85	$^{\circ}$ C
N	Fan Out (TTL load)	Single Channel		8	TTL Loads
		Dual Channel		5	
$R_L$	Output Pull-up		330	4000	$\Omega$

Functional operation above the stresses listed in the Recommended Operating Ranges is not implied. Extended exposure to stresses beyond the Recommended Operating Ranges limits may affect device reliability.

\*6.3 mA is a guard banded value which allows for at least 20% CTR degradation. Initial input current threshold value is 5.0 mA or less.

## ELECTRICAL CHARACTERISTICS

( $T_A = -40^{\circ}$ C TO  $+85^{\circ}$ C UNLESS OTHERWISE SPECIFIED)

### INDIVIDUAL COMPONENT CHARACTERISTICS

Symbol	Parameter	Test Conditions	Min.	Typ.*	Max.	Unit
--------	-----------	-----------------	------	-------	------	------

#### EMITTER

$V_F$	Input Forward Voltage	$I_F = 10$ mA			1.8	V
		$T_A = 25^{\circ}$ C			1.75	
$B_{VR}$	Input Reverse Breakdown Voltage	$I_R = 10$ $\mu$ A	5.0			V
$\Delta V_F / \Delta T_A$	Input Diode Temperature Coefficient	$I_F = 10$ mA		-1.5		mV/ $^{\circ}$ C

#### DETECTOR

$I_{CCH}$	High Level Supply Current	$I_F = 0$ mA, $V_E = 0.5$ V $V_{CC} = 5.5$ V	Single Channel			10	mA
			Dual Channel			15	
$I_{CCL}$	Low Level Supply Current	$I_F = 10$ mA, $V_E = 0.5$ V $V_{CC} = 5.5$ V	Single Channel			13	mA
			Dual Channel			21	
$I_{EL}$	Low Level Enable Current	$V_{CC} = 5.5$ V, $V_E = 0.5$ V	Single Channel			-1.6	mA
$I_{EH}$	High Level Enable Current	$V_{CC} = 5.5$ V, $V_E = 2.0$ V	Single Channel			-1.6	mA
$V_{EH}$	High Level Enable Voltage	$V_{CC} = 5.5$ V, $I_F = 10$ mA	Single Channel	2.0			V
$V_{EL}$	Low Level Enable Voltage	$V_{CC} = 5.5$ V, $I_F = 10$ mA (Note 3)	Single Channel			0.8	V

# HCPL0600, HCPL0601, HCPL0611, HCPL0637, HCPL0638, HCPL0639

## SWITCHING CHARACTERISTICS ( $T_A = -40^\circ\text{C}$ to $+85^\circ\text{C}$ , $V_{CC} = 5\text{ V}$ , $I_F = 7.5\text{ mA}$ unless otherwise specified)

Symbol	AC Characteristics	Test Conditions	Device	Min.	*	Max.	Unit
$T_{PLH}$	Propagation Delay Time to Output High Level	$R_L = 350\ \Omega$ , $T_A = 25^\circ\text{C}$ $C_L = 15\text{ pF}$ (Note 4) (Fig. 22)	All	20		75 100	ns
$T_{PHL}$	Propagation Delay Time to Output Low Level	$R_L = 350\ \Omega$ , $T_A = 25^\circ\text{C}$ $C_L = 15\text{ pF}$ (Note 5) (Fig. 22)	All	25		75 100	ns
$ T_{PHL} - T_{PLH} $	Pulse Width Distortion	$R_L = 350\ \Omega$ , $C_L = 15\text{ pF}$ (Fig. 20)	All			35	ns
$t_r$	Output Rise Time (10–90%)	$R_L = 350\ \Omega$ , $C_L = 15\text{ pF}$ (Note 6) (Fig. 22)	Single Ch Dual Ch		50 17		ns
$t_f$	Output Fall Time (90–10%)	$R_L = 350\ \Omega$ , $C_L = 15\text{ pF}$ (Note 7) (Fig. 22)	Single Ch Dual Ch		12 5		ns
$t_{ELH}$	Enable Propagation Delay Time to Output High Level	$I_F = 7.5\text{ mA}$ , $V_{EH} = 3.5\text{ V}$ , $R_L = 350\ \Omega$ , $C_L = 15\text{ pF}$ (Note 8) (Fig. 23)	HCPL0600 HCPL0601 HCPL0611		20		ns
$t_{EHL}$	Enable Propagation Delay Time to Output Low Level	$I_F = 7.5\text{ mA}$ , $V_{EH} = 3.5\text{ V}$ , $R_L = 350\ \Omega$ , $C_L = 15\text{ pF}$ (Note 9) (Fig. 23)	HCPL0600 HCPL0601 HCPL0611		20		ns
$ CM_H $	Common Mode Transient Immunity (at Output High Level)	$R_L = 350\ \Omega$ , $T_A = 25^\circ\text{C}$ , $I_F = 0\text{ mA}$ , $V_{OH}(\text{Min.}) = 2.0\text{ V}$ (Note 10) (Fig. 24, 25)	$ V_{CM}  = 10\text{ V}$	HCPL0600 HCPL0637	5,000		V/ $\mu\text{s}$
			$ V_{CM}  = 50\text{ V}$	HCPL0601 HCPL0638	10,000		
			$ V_{CM}  = 1,000\text{ V}$	HCPL0611	15,000		
				HCPL0639	25,000		
$ CM_L $	Common Mode Transient Immunity (at Output Low Level)	$R_L = 350\ \Omega$ , $T_A = 25^\circ\text{C}$ , $I_F = 7.5\text{ mA}$ , $V_{OL}(\text{Max.}) = 0.8\text{ V}$ (Note 11) (Fig. 24, 25)	$ V_{CM}  = 10\text{ V}$	HCPL0600 HCPL0637	5,000		V/ $\mu\text{s}$
			$ V_{CM}  = 50\text{ V}$	HCPL0601 HCPL0638	10,000		
			$ V_{CM}  = 1,000\text{ V}$	HCPL0611	15,000		
				HCPL0639	25,000		

## TRANSFER CHARACTERISTICS ( $T_A = -40^\circ\text{C}$ to $+85^\circ\text{C}$ unless otherwise specified)

Symbol	DC Characteristics	Test Conditions	Min.	Typ.*	Max.	Unit
$I_{OH}$	High Level Output Current	$V_{CC} = 5.5\text{ V}$ , $V_O = 5.5\text{ V}$ , $I_F = 250\ \mu\text{A}$ , $V_E = 2.0\text{ V}$ (Note 3)			100	$\mu\text{A}$
$V_{OL}$	Low Level Output Voltage	$V_{CC} = 5.5\text{ V}$ , $I_F = 5\text{ mA}$ , $V_E = 2.0\text{ V}$ , $I_{OL} = 13\text{ mA}$ (Note 3)			0.6	V
$I_{FT}$	Input Threshold Current	$V_{CC} = 5.5\text{ V}$ , $V_O = 0.6\text{ V}$ , $V_E = 2.0\text{ V}$ , $I_{OL} = 13\text{ mA}$			5	mA

\*All typical values are at  $V_{CC} = 5\text{ V}$ ,  $T_A = 25^\circ\text{C}$ .

# HCPL0600, HCPL0601, HCPL0611, HCPL0637, HCPL0638, HCPL0639

## ISOLATION CHARACTERISTICS ( $T_A = -40^\circ\text{C}$ to $+85^\circ\text{C}$ unless otherwise specified)

Symbol	Characteristics	Test Conditions	Min.	Typ.*	Max.	Unit
$I_{I-O}$	Input-Output Insulation Leakage Current	Relative humidity = 45%, $T_A = 25^\circ\text{C}$ , $t = 5$ s, $V_{I-O} = 3000$ VDC (Note 12)			1.0*	$\mu\text{A}$
$V_{ISO}$	Withstand Insulation Test Voltage	$R_H < 50\%$ , $T_A = 25^\circ\text{C}$ , $I_{I-O} \leq 2$ $\mu\text{A}$ , $t = 1$ min. (Note 12)	3750			$V_{RMS}$
$R_{I-O}$	Resistance (Input to Output)	$V_{I-O} = 500$ V (Note 12)		$10^{12}$		$\Omega$
$C_{I-O}$	Capacitance (Input to Output)	$f = 1$ MHz (Note 12)		0.6		pF

\*All typical values are at  $V_{CC} = 5$  V,  $T_A = 25^\circ\text{C}$ .

Product parametric performance is indicated in the Electrical Characteristics for the listed test conditions, unless otherwise noted. Product performance may not be indicated by the Electrical Characteristics if operated under different conditions.

### Notes:

- The  $V_{CC}$  supply to each optoisolator must be bypassed by a 0.1  $\mu\text{F}$  capacitor or larger. This can be either a ceramic or solid tantalum capacitor with good high frequency characteristic and should be connected as close as possible to the package  $V_{CC}$  and GND pins of each device.
- Enable Input – No pull up resistor required as the device has an internal pull up resistor.
- $t_{PLH}$  – Propagation delay is measured from the 3.75 mA level on the HIGH to LOW transition of the input current pulse to the 1.5 V level on the LOW to HIGH transition of the output voltage pulse.
- $t_{PHL}$  – Propagation delay is measured from the 3.75 mA level on the LOW to HIGH transition of the input current pulse to the 1.5 V level on the HIGH to LOW transition of the output voltage pulse.
- $t_r$  – Rise time is measured from the 90% to the 10% levels on the LOW to HIGH transition of the output pulse.
- $t_f$  – Fall time is measured from the 10% to the 90% levels on the HIGH to LOW transition of the output pulse.
- $t_{ELH}$  – Enable input propagation delay is measured from the 1.5 V level on the HIGH to LOW transition of the input voltage pulse to the 1.5 V level on the LOW to HIGH transition of the output voltage pulse.
- $t_{EHL}$  – Enable input propagation delay is measured from the 1.5 V level on the LOW to HIGH transition of the input voltage pulse to the 1.5 V level on the HIGH to LOW transition of the output voltage pulse.
- $CM_H$  – The maximum tolerable rate of rise of the common mode voltage to ensure the output will remain in the high state (i.e.,  $V_{OUT} > 2.0$  V). Measured in volts per microsecond (V/ $\mu\text{s}$ ).
- $CM_L$  – The maximum tolerable rate of fall of the common mode voltage to ensure the output will remain in the low output state (i.e.,  $V_{OUT} < 0.8$  V). Measured in volts per microsecond (V/ $\mu\text{s}$ ).
- Device considered a two-terminal device: Pins 1, 2, 3 and 4 shorted together, and Pins 5, 6, 7 and 8 shorted together.

TYPICAL PERFORMANCE CURVES

(HCPL0600, HCPL0601 and HCPL0611 only)

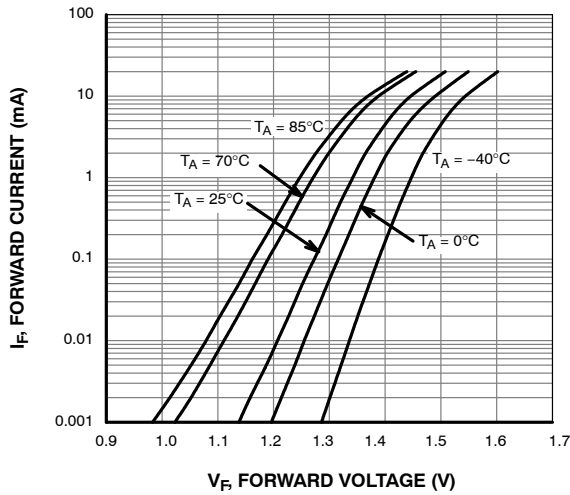

Figure 3. Forward Current vs. Input Forward Voltage

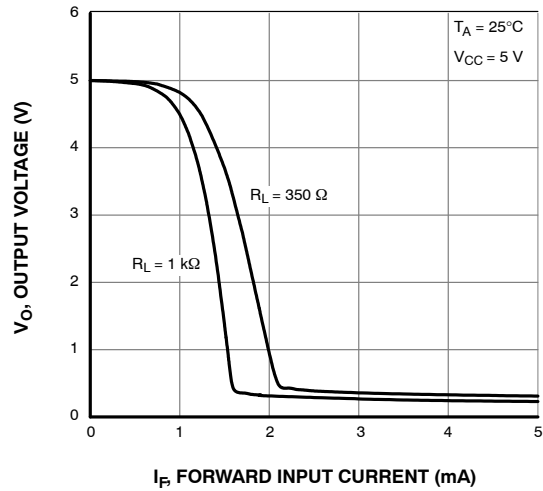

Figure 4. Output Voltage vs. Forward Current

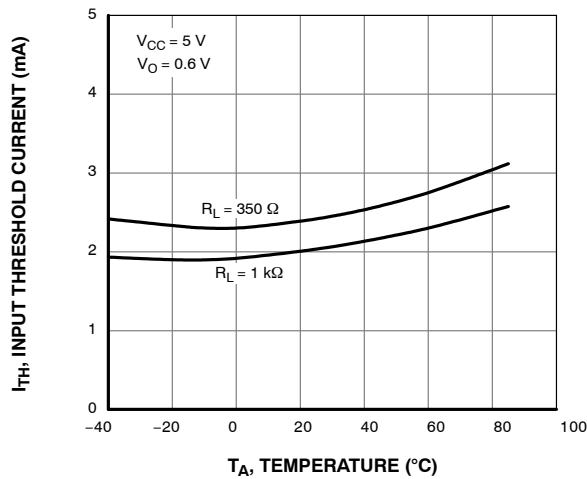

Figure 5. Input Threshold Current vs. Temperature

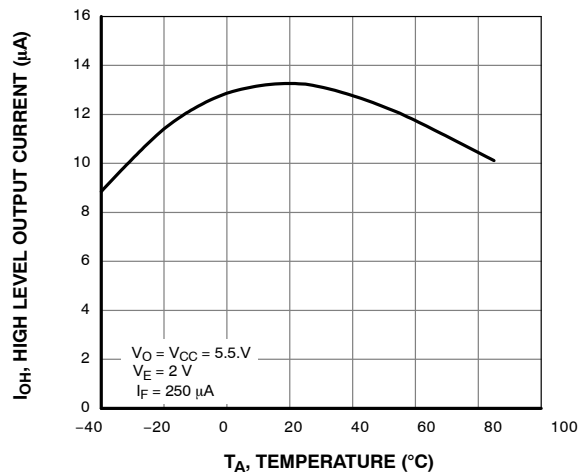

Figure 6. High Level Output Current vs. Temperature

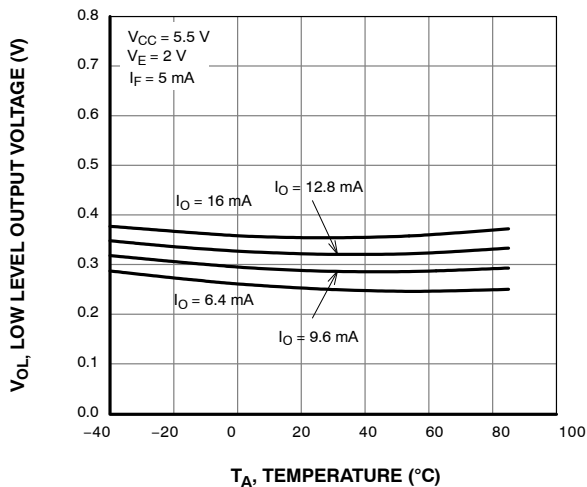

Figure 7. Low Level Output Voltage vs. Temperature

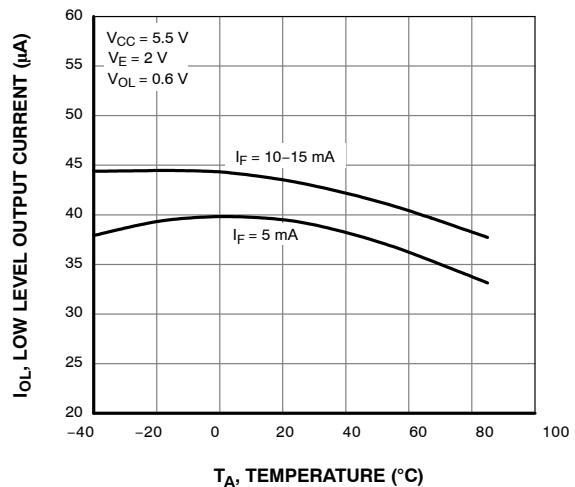

Figure 8. Low Level Output Current vs. Temperature

TYPICAL PERFORMANCE CURVES

(HCPL0600, HCPL0601 and HCPL0611 only)

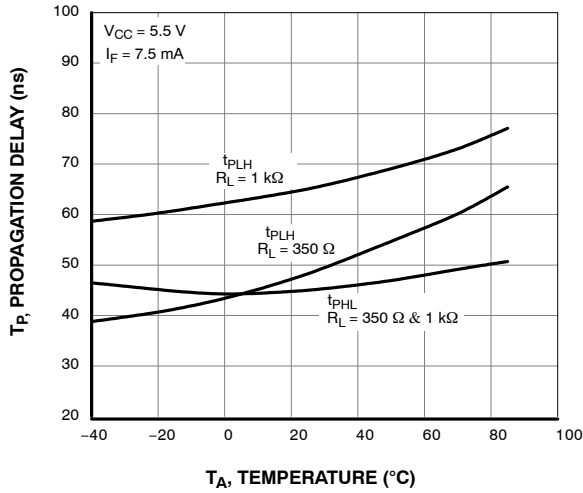

Figure 9. Propagation Delay vs. Temperature

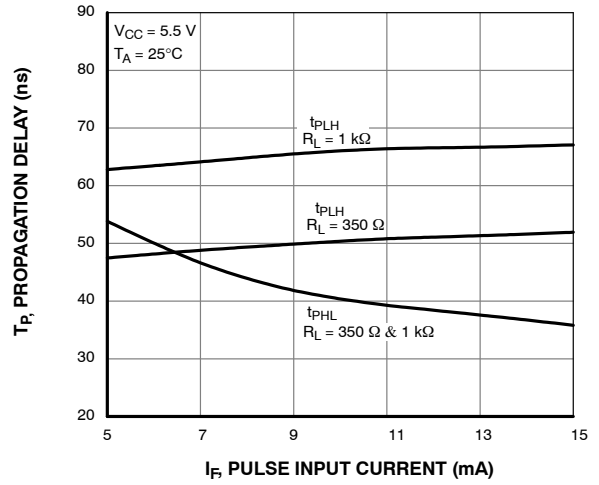

Figure 10. Propagation Delay vs. Pulse Input Current

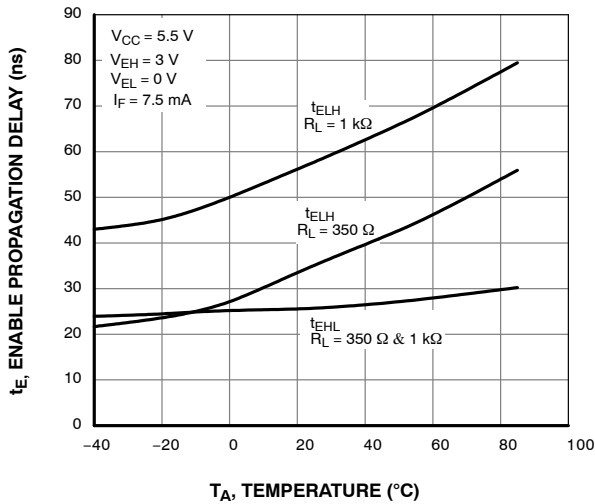

Figure 11. Typical Enable Propagation Delay vs. Temperature

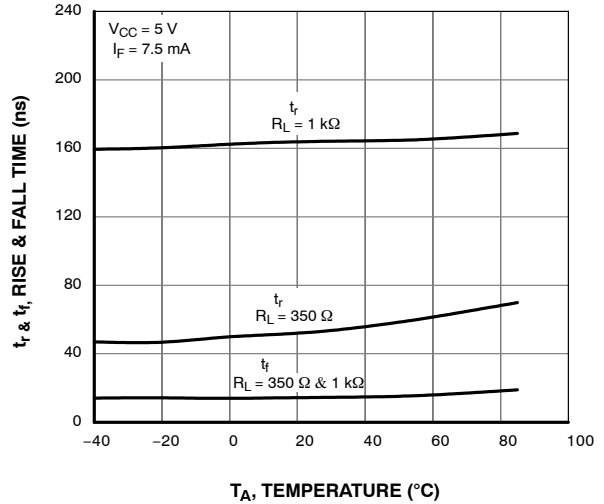

Figure 12. Typical Rise and Fall Time vs. Temperature

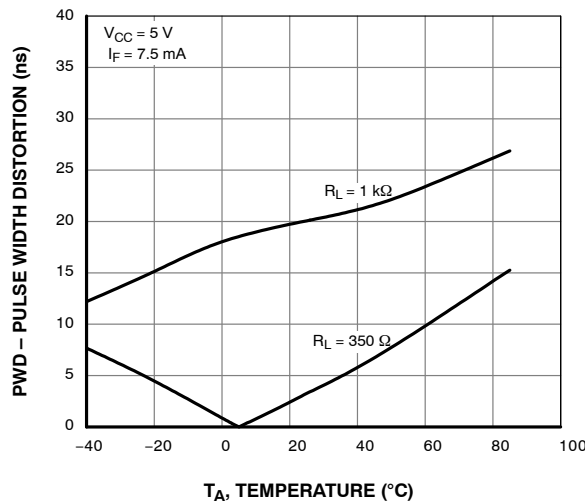

Figure 13. Typical Pulse Width Distortion vs. Temperature

TYPICAL PERFORMANCE CURVES

(HCPL0637, HCPL0638 and HCPL0639 only)

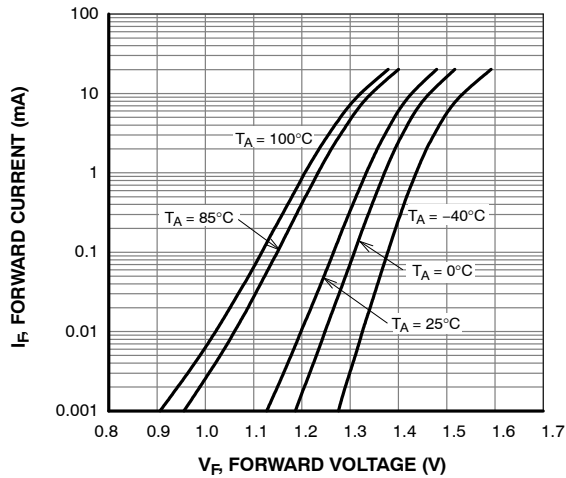

Figure 14. Input Forward Current vs. Forward Voltage

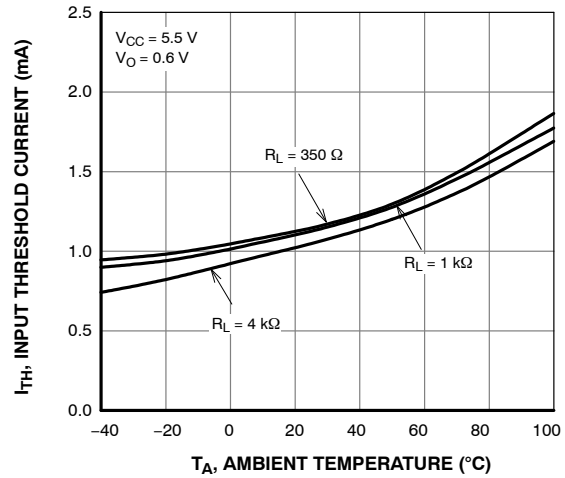

Figure 15. Input Threshold Current vs. Ambient Temperature

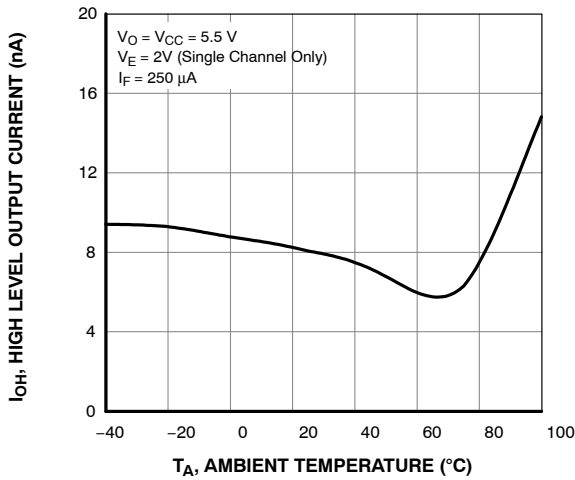

Figure 16. High Level Output Current vs. Ambient Temperature

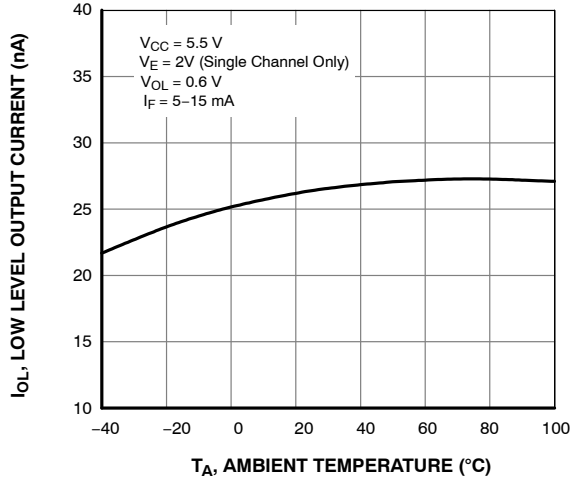

Figure 17. Low Level Output Current vs. Ambient Temperature

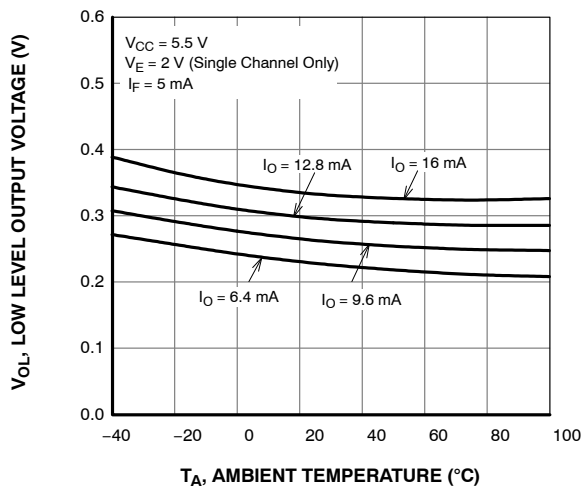

Figure 18. Low Level Output Voltage vs. Ambient Temperature

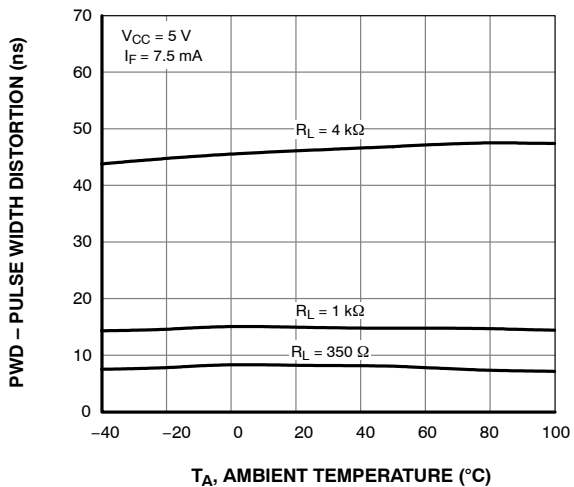

Figure 19. Pulse Width Distortion vs. Ambient Temperature

TYPICAL PERFORMANCE CURVES

(HCPL0637, HCPL0638 and HCPL0639 only)

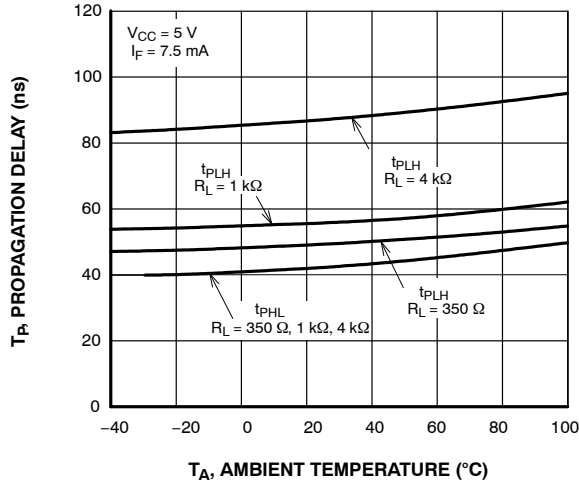

Figure 20. Propagation Delay vs. Ambient Temperature

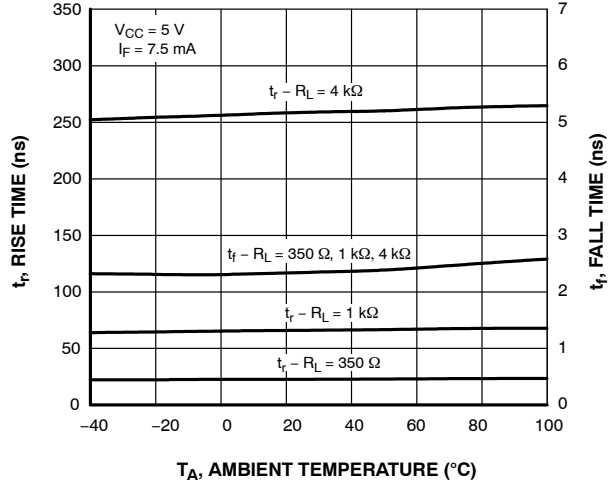

Figure 21. Rise and Fall Times vs. Ambient Temperature

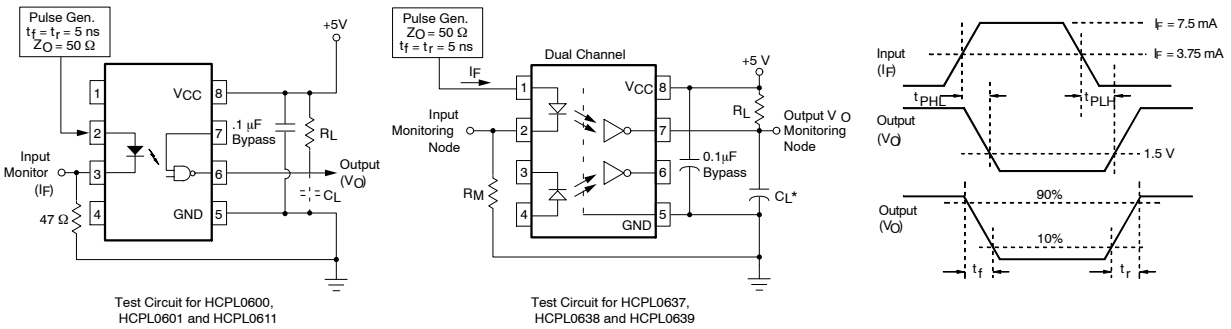

Figure 22. Test Circuit and Waveforms for  $t_{PLH}$ ,  $t_{PHL}$ ,  $t_r$  and  $t_f$

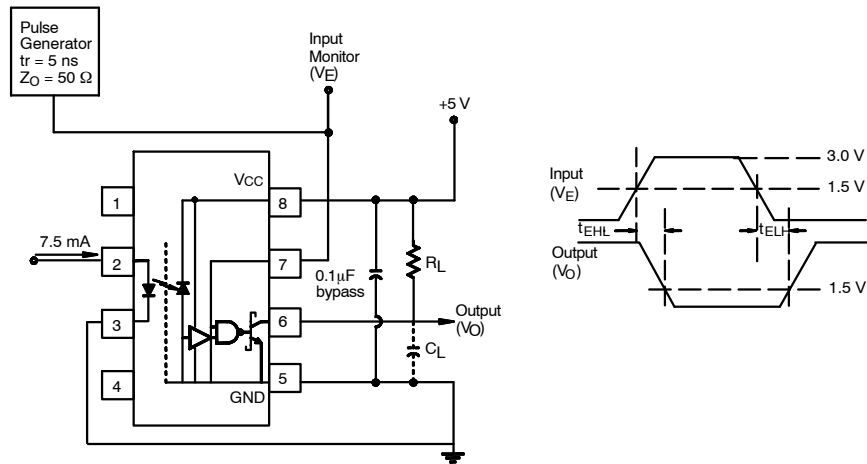

Figure 23. Test Circuit  $t_{EHL}$  and  $t_{ELH}$

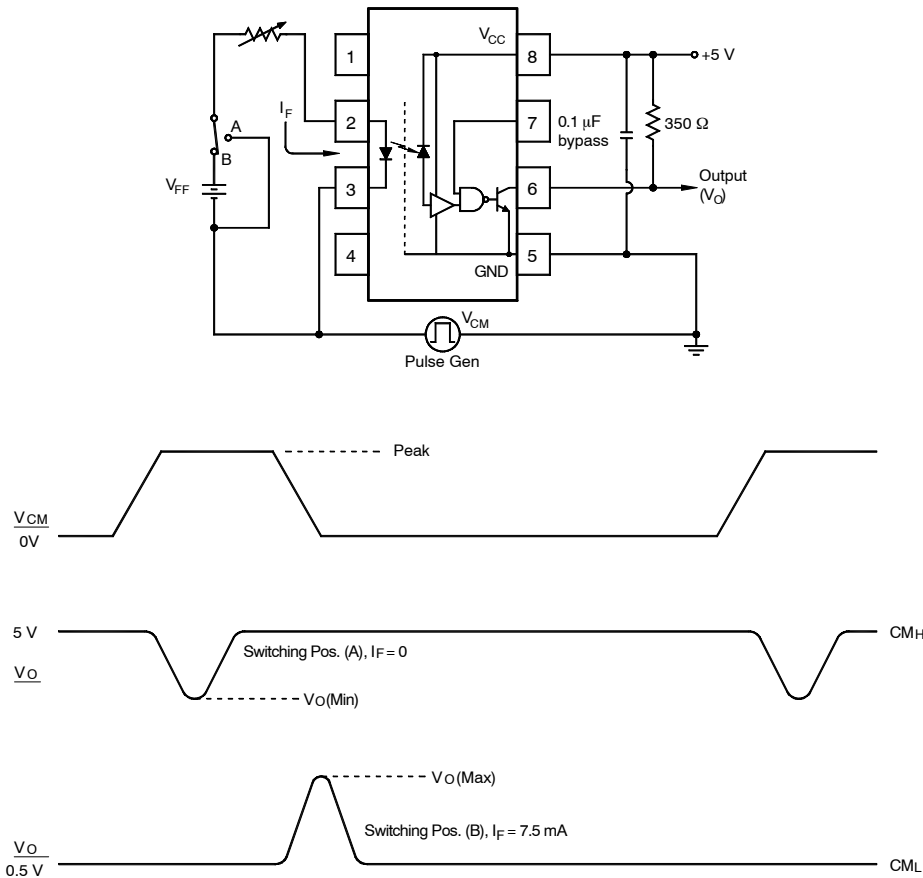

Figure 24. Test Circuit and Waveforms for Common Mode Transient Immunity (HCPL0600, HCPL0601 and HCPL0611)

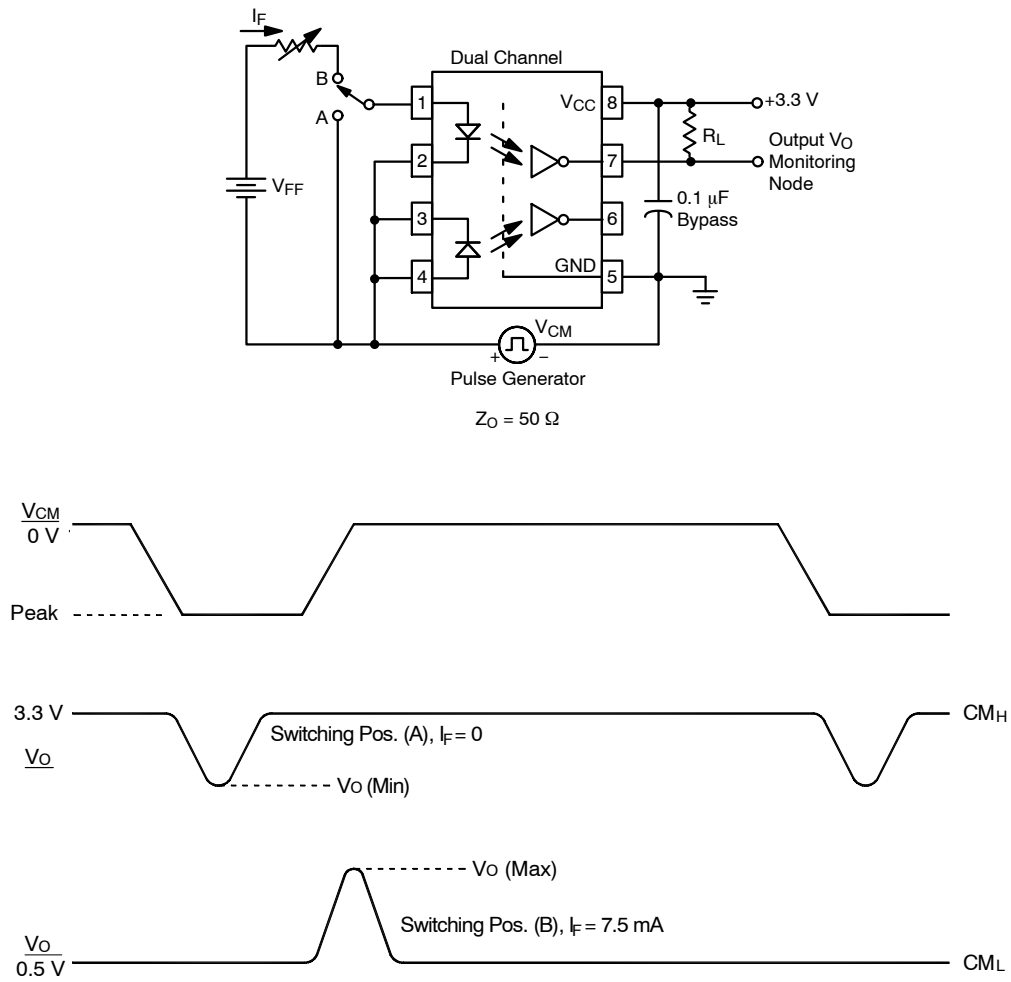

Figure 25. Test Circuit and Waveforms for Common Mode Transient Immunity (HCPL0637, HCPL0638 and HCPL0639)

**ORDERING INFORMATION**

Part Number	Package	Packing Method†
HCPL0600	Small Outline 8-Pin	Tube (50 Units)
HCPL0600R2	Small Outline 8-Pin	Tape and Reel (2500 Units)
HCPL0600V	Small Outline 8-Pin, DIN EN/IEC60747-5-5 Option	Tube (50 Units)
HCPL0600R2V	Small Outline 8-Pin, DIN EN/IEC60747-5-5 Option	Tape and Reel (2500 Units)

†For information on tape and reel specifications, including part orientation and tape sizes, please refer to our Tape and Reel Packaging Specifications Brochure, BRD8011/D.

13. The product orderable part number system listed in this table also applies to the HCPL0601, HCPL0611, HCPL0637, HCPL0638 and HCPL0639 product.

**CARRIER TAPE SPECIFICATIONS**

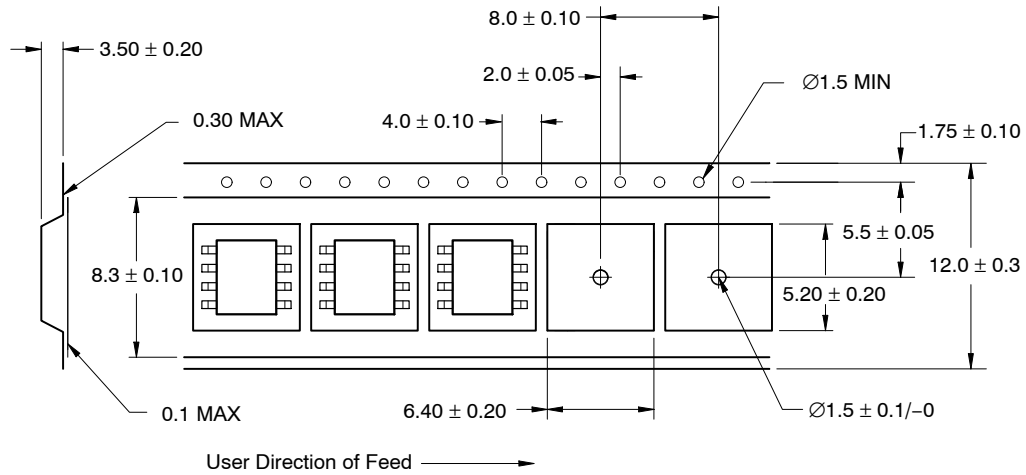

REFLOW PROFILE

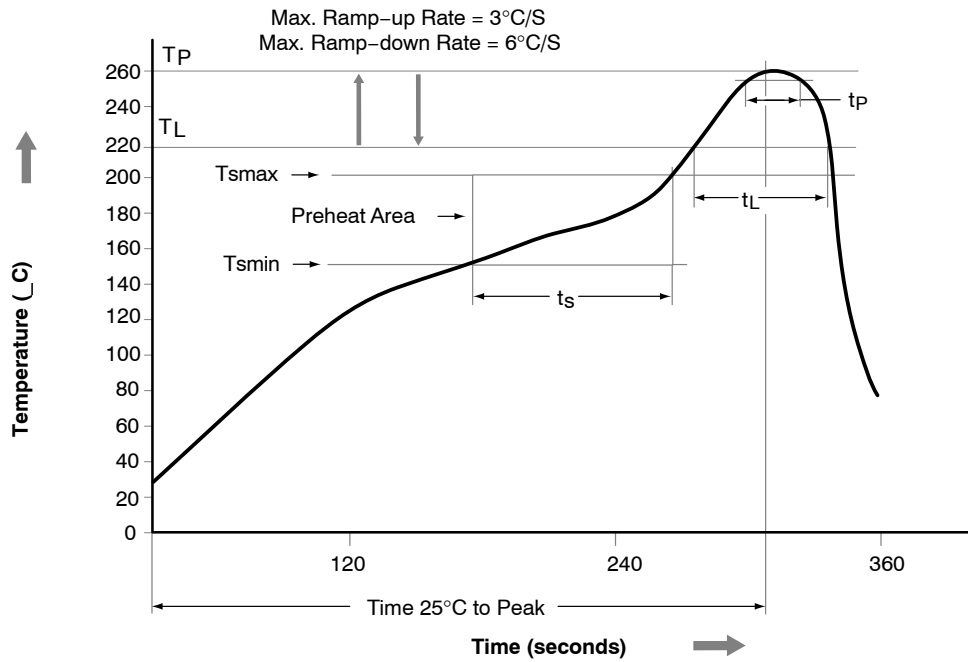

Profile Feature	Pb-Free Assembly Profile
Temperature Min. (T <sub>min</sub> )	150°C
Temperature Max. (T <sub>max</sub> )	200°C
Time (t <sub>s</sub> ) from (T <sub>min</sub> to T <sub>max</sub> )	60–120 seconds
Ramp-up Rate (t <sub>L</sub> to t <sub>p</sub> )	3°C/second max.
Liquidous Temperature (T <sub>L</sub> )	217°C
Time (t <sub>L</sub> ) Maintained Above (T <sub>L</sub> )	60–150 seconds
Peak Body Package Temperature	260°C +0°C / -5°C
Time (t <sub>p</sub> ) within 5°C of 260°C	30 seconds
Ramp-down Rate (T <sub>P</sub> to T <sub>L</sub> )	6°C/second max.
Time 25°C to Peak Temperature	8 minutes max.

SOIC8  
CASE 751DZ  
ISSUE O

DATE 30 SEP 2016

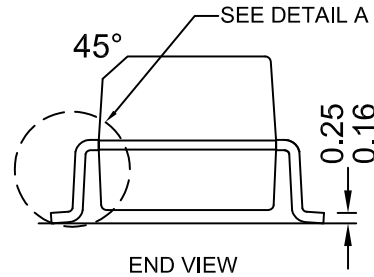
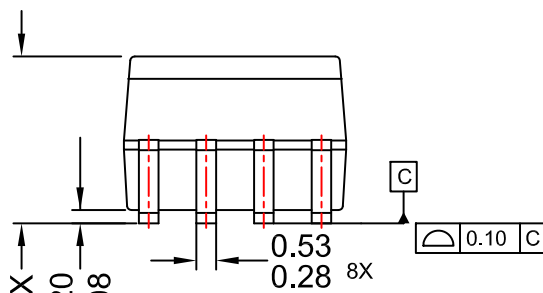
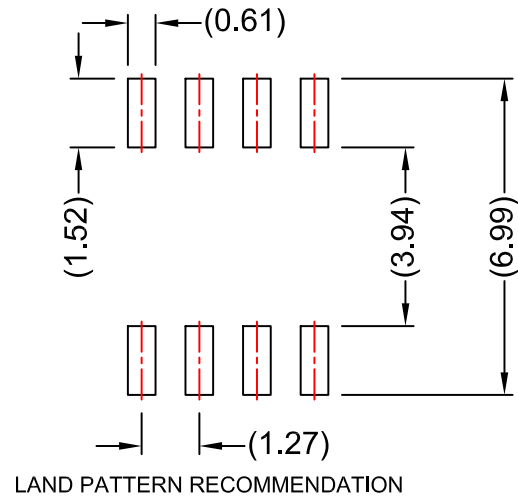
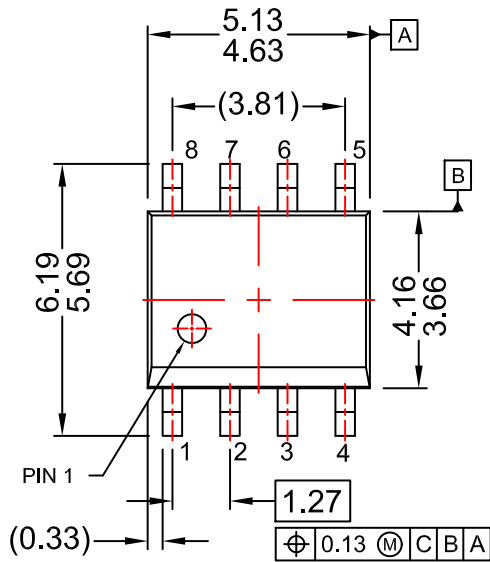

NOTES:

- A) NO STANDARD APPLIES TO THIS PACKAGE
- B) ALL DIMENSIONS ARE IN MILLIMETERS.
- C) DIMENSIONS DO NOT INCLUDE MOLD FLASH OR BURRS.
- D) LANDPATTERN STANDARD: SOIC127P600X175-8M.

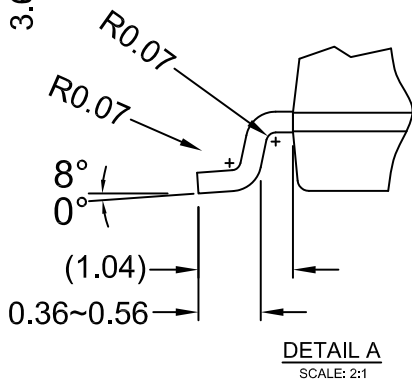

DOCUMENT NUMBER:	98AON13733G	Electronic versions are uncontrolled except when accessed directly from the Document Repository. Printed versions are uncontrolled except when stamped "CONTROLLED COPY" in red.
DESCRIPTION:	SOIC8	PAGE 1 OF 1

onsemi and ONSEMI are trademarks of Semiconductor Components Industries, LLC dba onsemi or its subsidiaries in the United States and/or other countries. onsemi reserves the right to make changes without further notice to any products herein. onsemi makes no warranty, representation or guarantee regarding the suitability of its products for any particular purpose, nor does onsemi assume any liability arising out of the application or use of any product or circuit, and specifically disclaims any and all liability, including without limitation special, consequential or incidental damages. onsemi does not convey any license under its patent rights nor the rights of others.

**onsemi**, **Onsemi**, and other names, marks, and brands are registered and/or common law trademarks of Semiconductor Components Industries, LLC dba "**onsemi**" or its affiliates and/or subsidiaries in the United States and/or other countries. **onsemi** owns the rights to a number of patents, trademarks, copyrights, trade secrets, and other intellectual property. A listing of **onsemi**'s product/patent coverage may be accessed at [www.onsemi.com/site/pdf/Patent-Marking.pdf](http://www.onsemi.com/site/pdf/Patent-Marking.pdf). **onsemi** reserves the right to make changes at any time to any products or information herein, without notice. The information herein is provided "as-is" and **onsemi** makes no warranty, representation or guarantee regarding the accuracy of the information, product features, availability, functionality, or suitability of its products for any particular purpose, nor does **onsemi** assume any liability arising out of the application or use of any product or circuit, and specifically disclaims any and all liability, including without limitation special, consequential or incidental damages. Buyer is responsible for its products and applications using **onsemi** products, including compliance with all laws, regulations and safety requirements or standards, regardless of any support or applications information provided by **onsemi**. "Typical" parameters which may be provided in **onsemi** data sheets and/or specifications can and do vary in different applications and actual performance may vary over time. All operating parameters, including "Typicals" must be validated for each customer application by customer's technical experts. **onsemi** does not convey any license under any of its intellectual property rights nor the rights of others. **onsemi** products are not designed, intended, or authorized for use as a critical component in life support systems or any FDA Class 3 medical devices or medical devices with a same or similar classification in a foreign jurisdiction or any devices intended for implantation in the human body. Should Buyer purchase or use **onsemi** products for any such unintended or unauthorized application, Buyer shall indemnify and hold **onsemi** and its officers, employees, subsidiaries, affiliates, and distributors harmless against all claims, costs, damages, and expenses, and reasonable attorney fees arising out of, directly or indirectly, any claim of personal injury or death associated with such unintended or unauthorized use, even if such claim alleges that **onsemi** was negligent regarding the design or manufacture of the part. **onsemi** is an Equal Opportunity/Affirmative Action Employer. This literature is subject to all applicable copyright laws and is not for resale in any manner.

## ADDITIONAL INFORMATION

### TECHNICAL PUBLICATIONS:

Technical Library: [www.onsemi.com/design/resources/technical-documentation](http://www.onsemi.com/design/resources/technical-documentation)  
onsemi Website: [www.onsemi.com](http://www.onsemi.com)

### ONLINE SUPPORT: [www.onsemi.com/support](http://www.onsemi.com/support)

For additional information, please contact your local Sales Representative at [www.onsemi.com/support/sales](http://www.onsemi.com/support/sales)