

Configurable Dual Supply Octal Transceiver

with 3-State Outputs for 3 V Systems

MC74LVXC3245

The 74LVXC3245 is a 24-pin dual-supply, octal configurable voltage interface transceiver especially well suited for PCMCIA and other real time configurable I/O applications. The V_{CCA} pin accepts a 3.0 V supply level; the A port is a dedicated 3.0 V port. The V_{CCB} pin accepts a 3.0 V-to-5.0 V supply level. The B port is configured to track the V_{CCB} supply level. A 5.0 V level on the V_{CCB} pin will configure the I/O pins at a 5.0 V level and a 3.0 V V_{CCB} will configure the I/O pins at a 3.0 V level. The A port interfaces with a 3.0 V host system and the B port to the card slots. This device will allow the V_{CCB} voltage source pin and I/O pins on the B port to float when \overline{OE} is High. This feature is necessary to buffer data to and from a PCMCIA socket that permits PCMCIA cards to be inserted and removed during normal operation. The Transmit/Receive (T/\overline{R}) input determines the direction of data flow. Transmit (active-High) enables data from the A port to B port. Receive (active-Low) enables data from the B port to the A port.

Features

- Bidirectional Interface Between 3.0 V and 3.0 V/5.0 V Buses
- Control Inputs Compatible with TTL Level
- Outputs Source/Sink Up to 24 mA
- Guaranteed Simultaneous Switching Noise Level and Dynamic Threshold Performance
- Available in SOIC and TSSOP Packages
- Flexible V_{CCB} Operating Range
- Allows B Port and V_{CCB} to Float Simultaneously When \overline{OE} is High
- Functionally Compatible With the 74 Series 245
- These Devices are Pb-Free and are RoHS Compliant

MARKING DIAGRAMS

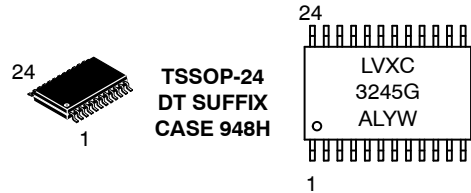
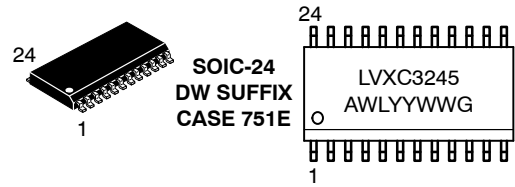

LVXC3245 = Specific Device Code
 A = Assembly Location
 WL, L = Wafer Lot
 Y = Year
 WW, W = Work Week
 G = Pb-Free Package
 (Note: Microdot may be in either location)

ORDERING INFORMATION

See detailed ordering and shipping information in the package dimensions section on page 5 of this data sheet.

NOTE: Some of the devices on this data sheet have been **DISCONTINUED**. Please refer to the table on page 5.

MC74LVXC3245

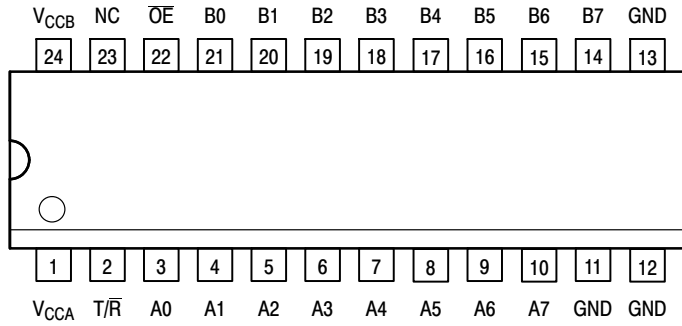

Figure 1. 24-Lead Pinout (Top View)

PIN NAMES

Pins	Function
OE	Output Enable Input
T/R	Transmit/Receive Input
A0–A7	Side A 3-State Inputs or 3-State Outputs
B0–B7	Side B 3-State Inputs or 3-State Outputs

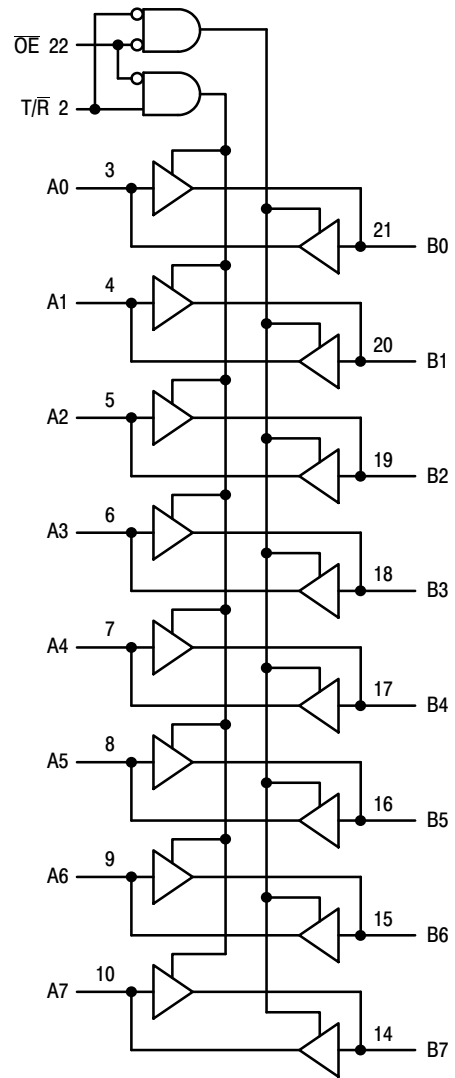

Figure 2. Logic Diagram

INPUTS		OPERATING MODE Non-Inverting
OE	T/R	
L	L	B Data to A Bus
L	H	A Data to B Bus
H	X	Z

H = High Voltage Level; L = Low Voltage Level; Z = High Impedance State; X = High or Low Voltage Level and Transitions are Acceptable; for I_{CC} reasons, Do Not Float Inputs

MC74LVXC3245

MAXIMUM RATINGS

Symbol	Parameter	Value	Condition	Unit
V_{CCA}, V_{CCB}	DC Supply Voltage	-0.5 to +6.5		V
V_I	DC Input Voltage	$\overline{OE}, T/R$	-0.5 to $V_{CCA} + 0.5$	V
$V_{I/O}$	DC Input/Output Voltage	An	-0.5 to $V_{CCA} + 0.5$	V
		Bn	-0.5 to $V_{CCB} + 0.5$	V
I_{IK}	DC Input Diode Current	$\overline{OE}, T/R$	$V_I < GND$	mA
I_{OK}	DC Output Diode Current		$V_O < GND; V_O > V_{CC}$	mA
I_O	DC Output Source/Sink Current			mA
I_{CC}, I_{GND}	DC Supply Current	Per Output Pin Maximum Current	± 50 ± 200	mA
T_{STG}	Storage Temperature Range		-65 to +150	°C
	DC Latchup Source/Sink Current		± 300	mA

Stresses exceeding those listed in the Maximum Ratings table may damage the device. If any of these limits are exceeded, device functionality should not be assumed, damage may occur and reliability may be affected.

RECOMMENDED OPERATING CONDITIONS

Symbol	Parameter	Min	Max	Unit
V_{CCA}, V_{CCB}	Supply Voltage ($V_{CCA} \leq V_{CCB}$)	V_{CCA} 2.3 V_{CCB} 3.0	3.6 5.5	V
V_I	Input Voltage	$\overline{OE}, T/R$	V_{CCA}	V
$V_{I/O}$	Input/Output Voltage	An	V_{CCA}	V
		Bn	V_{CCB}	V
T_A	Operating Free-Air Temperature	-40	+85	°C
$\Delta t/\Delta V$	Minimum Input Edge Rate V_{IN} from 30% to 70% of V_{CC} ; V_{CC} at 3.0 V, 4.5 V, 5.5 V	0	8	ns/V

Functional operation above the stresses listed in the Recommended Operating Ranges is not implied. Extended exposure to stresses beyond the Recommended Operating Ranges limits may affect device reliability.

DC ELECTRICAL CHARACTERISTICS

Symbol	Parameter	Condition	V_{CCA}	V_{CCB}	$T_A = 25\text{ }^\circ\text{C}$		$T_A = -40\text{ to }+85\text{ }^\circ\text{C}$		Unit
					Typ	Guaranteed Limits			
V_{IHA}	Minimum HIGH Level Input Voltage	An \overline{OE} T/R	2.3	3.0		2.0	2.0	V	
			3.0	3.6		2.0	2.0		
			3.6	5.5		2.0	2.0		
V_{IHB}		Bn	2.3	3.0		2.00	2.00	V	
			3.0	3.6		2.00	2.00		
			3.6	5.5		3.85	3.85		
V_{ILA}	Maximum LOW Level Input Voltage	An \overline{OE} T/R	2.3	3.0		0.8	0.8	V	
			3.0	3.6		0.8	0.8		
			3.6	5.5		0.8	0.8		
V_{ILB}		Bn	2.3	3.0		0.80	0.80	V	
			3.0	3.6		0.80	0.80		
			3.6	5.5		1.65	1.65		
V_{OHA}	Minimum HIGH Level Output Voltage	$I_{OUT} = -100\text{ }\mu\text{A}$ $I_{OH} = -12\text{ mA}$ $I_{OH} = -24\text{ mA}$ $I_{OH} = -12\text{ mA}$ $I_{OH} = -24\text{ mA}$	3.0	3.0	2.99	2.90	2.90	V	
			3.0	3.0	2.85	2.56	2.46		
			3.0	3.0	2.65	2.35	2.25		
			2.3	3.0	2.50	2.30	2.20		
			2.3	4.5	2.30	2.10	2.00		
V_{OHB}		$I_{OUT} = -100\text{ }\mu\text{A}$ $I_{OH} = -12\text{ mA}$ $I_{OH} = -24\text{ mA}$ $I_{OH} = -24\text{ mA}$	3.0	3.0	2.99	2.90	2.90	V	
			3.0	3.0	2.85	2.56	2.46		
			3.0	3.0	2.65	2.35	2.25		
			3.0	4.5	4.25	3.86	3.76		

MC74LVXC3245

DC ELECTRICAL CHARACTERISTICS

Symbol	Parameter	Condition	V _{CCA}	V _{CCB}	T _A = 25 °C		T _A = -40 to +85 °C		Unit
					Typ	Guaranteed Limits			
V _{OLA}	Maximum LOW Level Output Voltage	I _{OUT} = 100 μA	3.0	3.0	0.002	0.10	0.10		V
		I _{OL} = 24 mA	3.0	3.0	0.21	0.36	0.44		
		I _{OL} = 12 mA	2.7	3.0	0.11	0.36	0.44		
		I _{OL} = 24 mA	2.7	4.5	0.22	0.42	0.50		
V _{OLB}		I _{OUT} = 100 μA	3.0	3.0	0.002	0.10	0.10		V
		I _{OL} = 24 mA	3.0	3.0	0.21	0.36	0.44		
		I _{OL} = 24 mA	3.0	4.5	0.18	0.36	0.44		
I _{IN}	Max Input Leakage Current	\overline{OE} , T/R	V _I = V _{CCA} , GND	3.6 3.6	3.6 5.5		±0.1 ±0.1	±1.0 ±1.0	μA
I _{OZA}	Max 3-State Output Leakage	A _n	V _I = V _{IH} , V _{IL} \overline{OE} = V _{CCA} V _O = V _{CCA} , GND	3.6 3.6	3.6 5.5		±0.5 ±0.5	±5.0 ±5.0	μA
I _{OZB}	Max 3-State Output Leakage	B _n	V _I = V _{IH} , V _{IL} \overline{OE} = V _{CCA} V _O = V _{CCB} , GND	3.6 3.6	3.6 5.5		±0.5 ±0.5	±5.0 ±5.0	μA
ΔI _{CC}	Maximum I _{CC} /Input	B _n	V _I = V _{CCB} -2.1 V	3.6	5.5	1.0	1.35	1.5	mA
		All Inputs	V _I = V _{CC} -0.6 V	3.6	3.6		0.35	0.5	mA
I _{CCA1}	Quiescent V _{CCA} Supply Current as B Port Floats		A _n = V _{CCA} or GND B _n = Open, \overline{OE} = V _{CCA} , T/R = V _{CCA} , V _{CCB} = Open	3.6	Open		5	50	μA
I _{CCA2}	Quiescent V _{CCA} Supply Current		A _n = V _{CCA} or GND B _n = V _{CCB} or GND, \overline{OE} = GND, T/R = GND	3.6 3.6	3.6 5.5		5 5	50 50	μA
			A _n = V _{CCA} or GND B _n = V _{CCB} or GND, \overline{OE} = GND, T/R = V _{CCA}	3.6 3.6	3.6 5.5		5 8	50 80	
V _{OLPA}	Quiet Output Max Dynamic V _{OL}		Notes 1, 2	3.3 3.3	3.3 5.0		0.8 0.8		V
V _{OLPB}			Notes 1, 2	3.3 3.3	3.3 5.0		0.8 1.5		V
V _{OLVA}	Quiet Output Min Dynamic V _{OL}		Notes 1, 2	3.3 3.3	3.3 5.0		-0.8 -0.8		V
V _{OLVB}			Notes 1, 2	3.3 3.3	3.3 5.0		-0.8 -1.2		V
V _{IHDA}	Min HIGH Level Dynamic Input Voltage		Notes 1, 3	3.3 3.3	3.3 5.0		2.0 2.0		V
V _{IHDB}			Notes 1, 3	3.3 3.3	3.3 5.0		2.0 3.5		V
V _{ILDA}	Max LOW Level Dynamic Input Voltage		Notes 1, 3	3.3 3.3	3.3 5.0		0.8 0.8		V
V _{ILDB}			Notes 1, 3	3.3 3.3	3.3 5.0		0.8 1.5		V

Product parametric performance is indicated in the Electrical Characteristics for the listed test conditions, unless otherwise noted. Product performance may not be indicated by the Electrical Characteristics if operated under different conditions.

1. Worst case package.
2. Max number of outputs defined as (n). Data inputs are driven 0 V to V_{CC} level; one output at GND.
3. Max number of data inputs (n) switching. (n-1) inputs switching 0 V to V_{CC} level. Input under test switching: V_{CC} level to threshold (V_{IHD}), 0 V to threshold (V_{ILD}), f = 1 MHz.

MC74LVXC3245

AC ELECTRICAL CHARACTERISTICS

Symbol	Parameter	$T_A = -40 \text{ to } +85 \text{ }^\circ\text{C}; C_L = 50 \text{ pF}$						Unit
		$V_{CCA} = 2.7\text{--}3.6 \text{ V}$ $V_{CCB} = 4.5\text{--}5.5 \text{ V}$			$V_{CCA} = 2.7\text{--}3.6 \text{ V}$ $V_{CCB} = 3.0\text{--}3.6 \text{ V}$			
		Min	Typ (Note 4)	Max	Min	Typ (Note 5)	Max	
t_{PHL} t_{PLH}	Propagation Delay A to B	1.0 1.0	4.8 3.9	8.5 7.0	1.0 1.0	5.5 5.2	9.0 8.5	ns
t_{PHL} t_{PLH}	Propagation Delay B to A	1.0 1.0	3.8 4.3	7.0 8.0	1.0 1.0	4.4 5.1	7.5 8.0	ns
t_{PZL} t_{PZH}	Output Enable Time \overline{OE} to B	1.0 1.0	4.7 4.8	8.5 9.0	1.0 1.0	6.0 6.1	9.5 10.0	ns
t_{PZL} t_{PZH}	Output Enable Time \overline{OE} to A	1.0 1.0	5.9 5.4	10.0 9.5	1.0 1.0	6.4 5.8	10.5 9.5	ns
t_{PHZ} t_{PLZ}	Output Disable Time \overline{OE} to B	1.0 1.0	4.0 3.8	8.5 8.0	1.0 1.0	6.3 4.5	10.0 8.5	ns
t_{PHZ} t_{PLZ}	Output Disable Time \overline{OE} to A	1.0 1.0	4.6 3.1	10.0 7.0	1.0 1.0	5.2 3.4	10.0 7.0	ns
t_{OSHL} t_{OSLH}	Output to Output Skew, Data to Output (Note 6)		1.0	1.5		1.0	1.5	ns

4. Typical values at $V_{CCA} = 3.3 \text{ V}$, $V_{CCB} = 5.0 \text{ V}$ at $25 \text{ }^\circ\text{C}$.

5. Typical values at $V_{CCA} = 3.3 \text{ V}$, $V_{CCB} = 3.3 \text{ V}$ at $25 \text{ }^\circ\text{C}$.

6. Skew is defined as the absolute value of the difference between the actual propagation delay for any two separate outputs of the same device. The specification applies to any outputs switching in the same direction, either HIGH-to-LOW (t_{OSHL}) or LOW-to-HIGH (t_{OSLH}); parameter guaranteed by design.

CAPACITIVE CHARACTERISTICS

Symbol	Parameter	Condition	Typical	Unit
C_{IN}	Input Capacitance	$V_{CCA} = 3.3 \text{ V}; V_{CCB} = 5.0 \text{ V}$	4.5	pF
$C_{I/O}$	Input/Output Capacitance	$V_{CCA} = 3.3 \text{ V}; V_{CCB} = 5.0 \text{ V}$	10	pF
C_{PD}	Power Dissipation Capacitance (Measured at 10 MHz)	A→B B→A $V_{CCB} = 5.0 \text{ V}$ $V_{CCA} = 3.3 \text{ V}$	50 40	pF

ORDERING INFORMATION

Device	Package	Shipping [†]
MC74LVXC3245DTR2G	TSSOP-24* (Pb-Free)	2500 Tape & Reel

DISCONTINUED (Note 7)

MC74LVXC3245DWRG	SOIC-24 (Pb-Free)	1000 Tape & Reel
MC74LVXC3245DTG	TSSOP-24* (Pb-Free)	62 Units / Rail
MC74LVXC3245DTRG	TSSOP-24* (Pb-Free)	2500 Tape & Reel

[†] For information on tape and reel specifications, including part orientation and tape sizes, please refer to our Tape and Reel Packaging Specifications Brochure, [BRD8011/D](#).

* This package is inherently Pb-Free.

7. **DISCONTINUED:** These devices are not recommended for new design. Please contact your onsemi representative for information. The most current information on these devices may be available on www.onsemi.com.

MC74LVXC3245

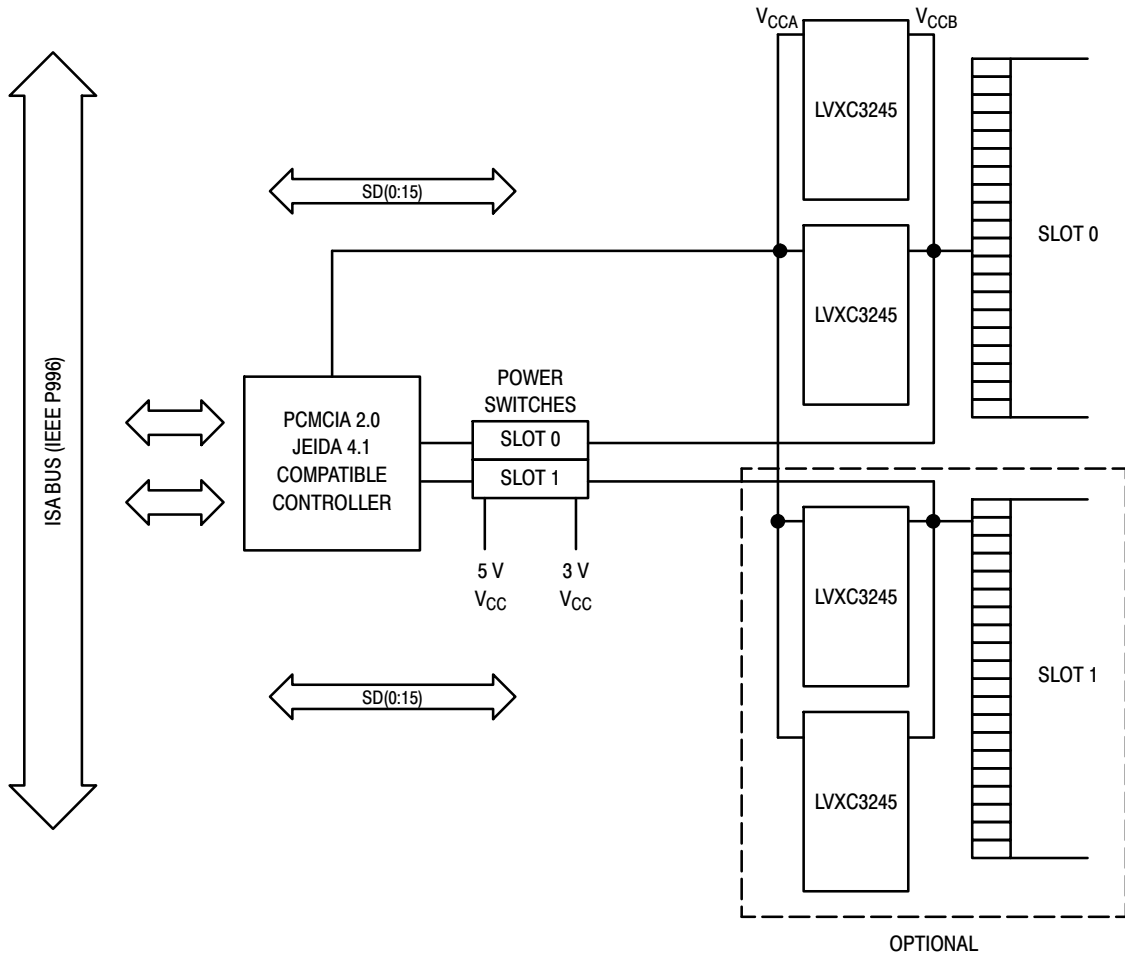

Figure 3. Block Diagram

Configurable I/O Application for PCMCIA Cards

The 74LVXC3245 is a dual-supply device well suited for PCMCIA configurable I/O applications. The LVXC3245 consumes less than 1mW of quiescent power in all modes of operation, making it ideal for low power notebook designs. The LVXC3245 meets all PCMCIA I/O voltage requirements at 5.0 V and 3.3 V operation. By tying the V_{CCB} pin to the card voltage supply, the PCMCIA card will always have

rail-to-rail output swings, maximizing the reliability of the interface.

The V_{CCA} pin must always be tied to a 3.3 V power supply. This voltage connection provides internal references needed to account for variations in V_{CCB}. When connected as in the figure above, the LVXC3245 meets all the voltage and current requirements of the ISA bus standard (IEEE P996).

MC74LVXC3245

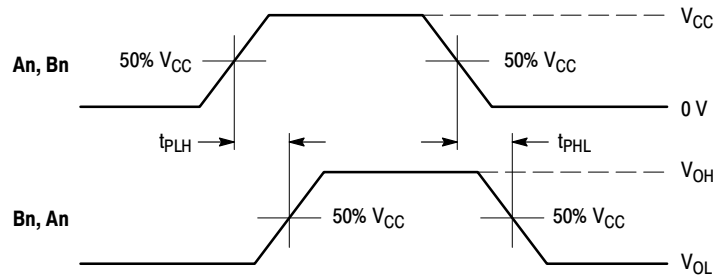

WAVEFORM 1 - PROPAGATION DELAYS

$t_R = t_F = 2.5 \text{ ns}$, 10% to 90%; $f = 1 \text{ MHz}$; $t_W = 500 \text{ ns}$

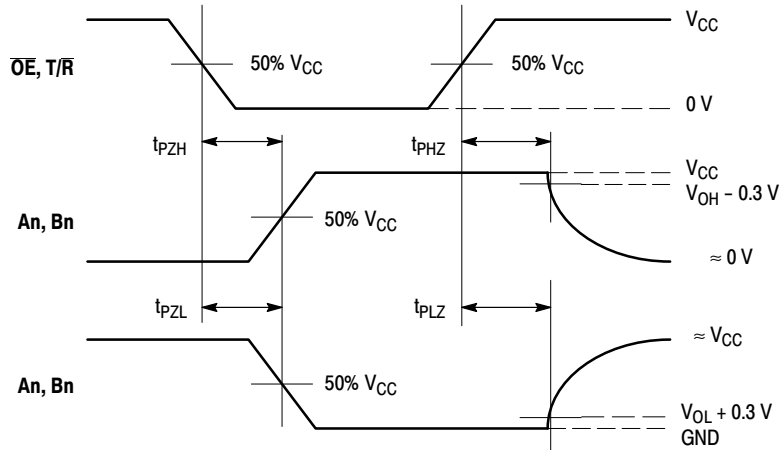

WAVEFORM 2 - OUTPUT ENABLE AND DISABLE TIMES

$t_R = t_F = 2.5 \text{ ns}$, 10% to 90%; $f = 1 \text{ MHz}$; $t_W = 500 \text{ ns}$

Figure 4. AC Waveforms

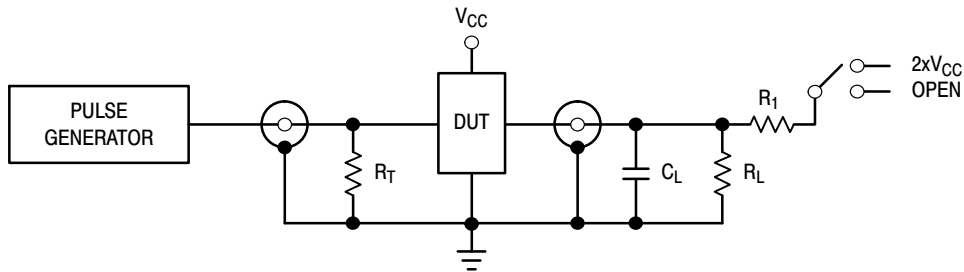

TEST	SWITCH
t_{PLH} , t_{PHL} , t_{PZH} , t_{PHZ}	Open
t_{PZL} , t_{PLZ}	$2xV_{CC}$

$C_L = 50 \text{ pF}$ or equivalent (Includes jig and probe capacitance)

$R_L = R_1 = 500 \Omega$ or equivalent

$R_T = Z_{OUT}$ of pulse generator (typically 50Ω)

Figure 5. Test Circuit

MC74LVXC3245

REVISION HISTORY

Revision	Description of Changes	Date
10	Update of DC Supply Voltage value in Maximum Ratings table (p.3), Update of the Ordering Information table (p.5)	12/15/2025

This document has undergone updates prior to the inclusion of this revision history table. The changes tracked here only reflect updates made on the noted approval dates.



SCALE 1:1

TSSOP24 7.8x4.4, 0.65P
CASE 948H
ISSUE B

DATE 21 JUN 2012

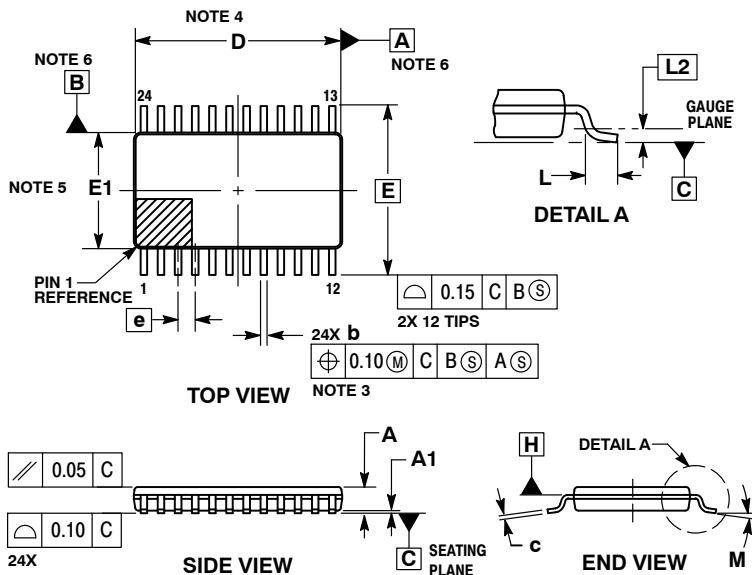

- NOTES:
1. DIMENSIONING AND TOLERANCING PER ASME Y14.5M, 1994.
 2. CONTROLLING DIMENSION: MILLIMETERS.
 3. DIMENSION b DOES NOT INCLUDE DAMBAR PROTRUSION. DAMBAR PROTRUSION SHALL BE 0.08 MAX AT MMC. DAMBAR CANNOT BE LOCATED ON THE LOWER RADIUS OF THE FOOT.
 4. DIMENSION D DOES NOT INCLUDE MOLD FLASH, PROTRUSIONS OR GATE BURRS. MOLD FLASH, PROTRUSIONS OR GATE BURRS SHALL NOT EXCEED 0.15 PER SIDE. DIMENSION D IS DETERMINED AT DATUM PLANE H.
 5. DIMENSION E1 DOES NOT INCLUDE INTERLEAD FLASH OR PROTRUSION. INTERLEAD FLASH OR PROTRUSION SHALL NOT EXCEED 0.25 PER SIDE. DIMENSION E1 IS DETERMINED AT DATUM PLANE H.
 6. DATUMS A AND B ARE DETERMINED AT DATUM PLANE H.
 7. A1 IS DEFINED AS THE VERTICAL DISTANCE FROM THE SEATING PLANE TO THE LOWEST POINT ON THE PACKAGE BODY.

DIM	MILLIMETERS	
	MIN	MAX
A	---	1.20
A1	0.05	0.15
b	0.19	0.30
c	0.09	0.20
D	7.70	7.90
E	6.40 BSC	
E1	4.30	4.50
e	0.65 BSC	
L	0.50	0.75
L2	0.25 BSC	
M	0°	8°

GENERIC MARKING DIAGRAM*

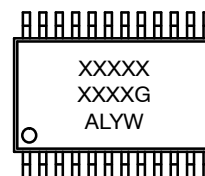

- XXXX = Specific Device Code
- A = Assembly Location
- L = Wafer Lot
- Y = Year
- W = Work Week
- G = Pb-Free Package

*For additional information on our Pb-Free strategy and soldering details, please download the onsemi Soldering and Mounting Techniques Reference Manual, SOLDERRM/D.

*This information is generic. Please refer to device data sheet for actual part marking. Pb-Free indicator, "G" or microdot "▪", may or may not be present. Some products may not follow the Generic Marking.

DOCUMENT NUMBER:	98ASH70248A	Electronic versions are uncontrolled except when accessed directly from the Document Repository. Printed versions are uncontrolled except when stamped "CONTROLLED COPY" in red.
DESCRIPTION:	TSSOP24 7.8X4.4, 0.65P	PAGE 1 OF 1

onsemi and ONSEMI are trademarks of Semiconductor Components Industries, LLC dba onsemi or its subsidiaries in the United States and/or other countries. onsemi reserves the right to make changes without further notice to any products herein. onsemi makes no warranty, representation or guarantee regarding the suitability of its products for any particular purpose, nor does onsemi assume any liability arising out of the application or use of any product or circuit, and specifically disclaims any and all liability, including without limitation special, consequential or incidental damages. onsemi does not convey any license under its patent rights nor the rights of others.

onsemi, **Onsemi**, and other names, marks, and brands are registered and/or common law trademarks of Semiconductor Components Industries, LLC dba "**onsemi**" or its affiliates and/or subsidiaries in the United States and/or other countries. **onsemi** owns the rights to a number of patents, trademarks, copyrights, trade secrets, and other intellectual property. A listing of **onsemi**'s product/patent coverage may be accessed at www.onsemi.com/site/pdf/Patent-Marking.pdf. **onsemi** reserves the right to make changes at any time to any products or information herein, without notice. The information herein is provided "as-is" and **onsemi** makes no warranty, representation or guarantee regarding the accuracy of the information, product features, availability, functionality, or suitability of its products for any particular purpose, nor does **onsemi** assume any liability arising out of the application or use of any product or circuit, and specifically disclaims any and all liability, including without limitation special, consequential or incidental damages. Buyer is responsible for its products and applications using **onsemi** products, including compliance with all laws, regulations and safety requirements or standards, regardless of any support or applications information provided by **onsemi**. "Typical" parameters which may be provided in **onsemi** data sheets and/or specifications can and do vary in different applications and actual performance may vary over time. All operating parameters, including "Typicals" must be validated for each customer application by customer's technical experts. **onsemi** does not convey any license under any of its intellectual property rights nor the rights of others. **onsemi** products are not designed, intended, or authorized for use as a critical component in life support systems or any FDA Class 3 medical devices or medical devices with a same or similar classification in a foreign jurisdiction or any devices intended for implantation in the human body. Should Buyer purchase or use **onsemi** products for any such unintended or unauthorized application, Buyer shall indemnify and hold **onsemi** and its officers, employees, subsidiaries, affiliates, and distributors harmless against all claims, costs, damages, and expenses, and reasonable attorney fees arising out of, directly or indirectly, any claim of personal injury or death associated with such unintended or unauthorized use, even if such claim alleges that **onsemi** was negligent regarding the design or manufacture of the part. **onsemi** is an Equal Opportunity/Affirmative Action Employer. This literature is subject to all applicable copyright laws and is not for resale in any manner.

ADDITIONAL INFORMATION

TECHNICAL PUBLICATIONS:

Technical Library: www.onsemi.com/design/resources/technical-documentation
onsemi Website: www.onsemi.com

ONLINE SUPPORT: www.onsemi.com/support

For additional information, please contact your local Sales Representative at www.onsemi.com/support/sales