

Conductive Polymer Capacitor

General Catalog 2025

- Conductive Polymer Aluminum Electrolytic Capacitors
- Conductive Polymer Tantalum Solid Capacitors
- Conductive Polymer Aluminum Solid Capacitors
- Conductive Polymer Hybrid Aluminum Electrolytic Capacitors

SP-Cap

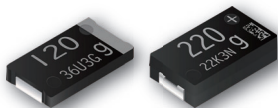

POSCAP

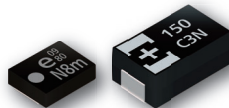

OS-CON

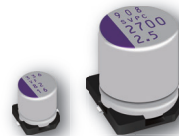

Hybrid



**IN Your
Innovation**



Electrolytic capacitors with conductive polymer to meet the needs of all electronic equipments in the world

SP-Cap, POSCAP, OS-CON, Hybrid

By using a high conductive polymer as the electrolyte, it has achieved in lower equivalent series resistance that could help and contribute excellent noise reduction and smoothing to an electrical fluctuation. In addition to that, that has excellence in product operational life, reliability and heat resistance.



* For details, see the right page

- **Low ESR**
 - Suitable as a decoupling capacitor to remove noises, because its impedance has ideal frequency characteristics.
 - Suitable as a smoothing capacitor for switching power supply or a backup capacitor for CPU because it allows large ripple current.
 - Suitable as a backup capacitor for the circuits that consumes large current at a high speed.
- **Long life**
- **Super low ESR**
- **Small size / Low profile**
- **Rush current resistance characteristics**
- **Wide capacitance range**
- **High voltage High reliability**
- **Environmental responsibility**
- **Temperature characteristics**
 - ESR has stable characteristics at when operating between -55°C to 150°C, suitable for applications used at low temperatures (under 0 °C).

Environmental responsibility

Principle

Industrial Solutions Company Group, Panasonic Corporation, Fulfills both environmental contribution and business growth, takes care of biodiversity, and contributes to create harmonization of environment, economy and society and to achieve a sustainable society.

RoHS compliance

All capacitors comply with RoHS directive (2011/65/EU) and (EU)2015/863.

Restricted Substance

Restricted substances of RoHS directive

- ◆ Cadmium(Cd) and it's compounds
- ◆ Lead(Pb) and it's compounds
- ◆ Mercury(Hg) and it's compounds
- ◆ Hexavalent chromium(Cr+6)
- ◆ Polybrominated biphenyls(PBBs)
- ◆ Polybrominated diphenyl ethers(PBDEs)
- ◆ Bis(2-ethylhexyl) phthalate (DEHP)
- ◆ Benzyl butyl phthalate (BBP)
- ◆ Dibutyl phthalate (DBP)
- ◆ Diisobutyl phthalate (DIBP)

Lead-free stance

All complete parts and homogenous materials of capacitors are lead-free. (JEITA, PHASE3)

ISO/IATF(ISO/TS)Certified

(1) Quality Approval

Factory(Site) Applicable standard	Organization	Certificate number	Acquisition years
●Uji factory (Kyoto)			
ISO 9001:2015	JQA	JQA-2524	1998.07.31
IATF 16949:2016	JQA	JQA-AU0162-14	2016.09.13
●Yamaguchi factory (Yamaguchi)			
ISO 9001:2015	JQA	JQA-2524	1998.07.31
IATF 16949:2016	JQA	JQA-AU0162-1	2007.02.23
●Panasonic Industrial Devices Saga Co., Ltd. (Former:SAGA SANYO Industries Co., Ltd.)(Saga)			
ISO 9001:2015	JQA	JQA-2524	1998.07.31
IATF 16949:2016	JQA	JQA-AU0162-10	2006.07.31
●PIDSG (Singapore)			
ISO 9001:2015	BSI	FM 612824	1994.12.08
●PICID(Former:SJC) (Indonesia)			
ISO 9001:2015	SGS	ID17/03853, ID19/04586	2006.03.26
IATF 16949:2016	SGS	ID19/04510	2011.03.01

(2) Environment Approval

Factory(Site) Applicable standard	Organization	Certificate number	Acquisition years
●Uji factory (Kyoto)			
ISO 14001:2015	JACO	EC10J0027	1996.12.26
●Yamaguchi factory (Yamaguchi)			
ISO 14001:2015	JACO	EC10J0027	1997.12.22
●Panasonic Industrial Devices Saga Co., Ltd. (Former:SAGA SANYO Industries Co., Ltd.)(Saga)			
ISO 14001:2015	JACO	EC10J0027	1998.03.10
●PIDSG (Singapore)			
ISO 9001:2015	AJA	AJA98/1151	1998.04.09
ISO 14001:2015	SGS	16/03617	2010.02.15
ISO 14001:2015	SGS	17/04090	2011.11.04

Conductive Polymer Capacitor INDEX

Item	Page
Safety and Legal Matters to Be Observed	1
Characteristics portfolio / Basic structure	2
Circuit example / Application	3

SP-Cap Conductive Polymer Aluminum Electrolytic Capacitors

Matters to Be Observed When Using This Product (SP-Cap)		5
Selection guide	Line-up / Diagram	8
	Voltage - Capacitance table	10
	Explanation of part numbers	12
	Mounting specifications	13
	Packing specifications	14
Series	JX : Endurance 125 °C 3000 h	15
	KX : Endurance 125 °C 5500 h	17
	TX : Endurance 135 °C 5500 h	19
	JZ : Large cap., 125 °C 3000 h	21
	KZ : Large cap., 125 °C 5500 h	23
	TZ : Large cap., 135 °C 5500 h	25
	CS,CT,CX : High voltage, Low profile	27
	SX : Large capacitance, Low ESR	30
	GX/GX-L : Large capacitance, Super low ESR	32
	LX : Large capacitance, Low ESR	34
	SR,LR,SS,LS,ST,LT : Low profile, Low ESR	36
	GY : Large capacitance, Super low ESR	38
	CY,SY : Endurance 85 °C 2000 h	40
HX : Endurance 125 °C 1000 h	42	
Replacement list for "Not recommended for new design"		44

POSCAP Conductive Polymer Tantalum Solid Capacitors

Matters to Be Observed When Using This Product (POSCAP)		48
Selection guide	Line-up / Diagram	50
	Voltage - Capacitance table	53
	Explanation of part numbers	57
	Mounting specifications	58
	Packing specifications	59
Series	TPS : 105 °C 2000 h	60
	TPSF : Super low ESR・Super low ESL	61
	TPE : Small size, Low profile	62
	TPF : Super low ESR	66
	TQT : High voltage, Large capacitance	68
	TQS : High voltage	69
	TQC : High voltage	70
	TA : Guaranteed at 85 °C 85 %RH	74
	TV : Guaranteed at 85 °C 85 %RH	76
	TH : 125 °C 1000 h	77
	TPB : Standard	79
	TC : 125 °C 1000 h	81
	TDC : 125 °C 1000 h	83
	TPC : Low profile	85
	Catalog deletion models	
EOL models		88

OS-CON Conductive Polymer Aluminum Solid Capacitors

Matters to Be Observed When Using This Product (OS-CON)		90	
Selection guide	Line-up / Diagram	93	
	Voltage - Capacitance table	99	
	Explanation of part numbers	104	
	Mounting specifications	105	
	Packing specifications	106	
Series	Surface mount type	SVT : 125°C 2000 h	108
		SVPT : 105°C 20000 h	110
		SVF : High voltage, 125°C 1000 h	112
		SVPK : High voltage, 125°C 1000 h	114
		SXV : Super high vol., 125°C 1000 h	116
		SVPG : High ripple current	118
		SVPF : High voltage, 105°C 5000 h	120
		SVPA : Low ESR	122
		SVPC : Low ESR	124
		SVPD : 125 °C 2000h	126
		SVPE : Low ESR	128
		SVPS : 105 °C 5000h	130
		SVQP : 125 °C 1000h	132
	SVP : Standard	134	
	Radial lead type	SEF : High voltage, 125°C 1000 h	136
		SEK : High voltage, 125°C 1000 h	138
		SEPG : High ripple current	140
		SXE : Super high vol., 125°C 1000 h	142
		SEPF : High voltage, 105°C 5000 h	144
		SEPC : Super low ESR	146
SEQP : High voltage		148	
SEP : Standard	150		

Hybrid Conductive Polymer Hybrid Aluminum Electrolytic Capacitors

Matters to Be Observed When Using This Product (Hybrid)		153	
Selection guide	Line-up / Diagram	159	
	Voltage - Capacitance table	161	
	Explanation of part numbers	163	
	Mounting specifications	165	
	Packing specifications	166	
Series	Surface mount type	ZA : 105 °C 10000 h	167
		ZC : 125 °C 4000 h	170
		ZK : 125 °C 4000 h	173
		ZKU : 125 °C 4000 h	175
		ZL : 135 °C 4000 h	177
		ZT : 125 °C 4000 h	179
		ZTU : 135 °C 4000 h	181
		ZV : 135 °C 4000 h	183
		ZVU : 135 °C 4000 h	185
		ZS : 135 °C 4000 h	187
		ZSU : 125 °C 4000 h	189
		ZU : 135 °C 4000 h	191
	Radial lead type	ZUU : 135 °C 4000 h	193
		ZE : 145 °C 2000 h	195
		ZF : 150 °C 1000 h	197
		ZA-A : 105 °C 10000 h	199
		ZC-A : 125 °C 4000 h	201
		ZK-A : 125 °C 4000 h	204
		ZKU-A : 125 °C 4000 h	206
		ZT-A : 125 °C 4000 h	208
		ZS-A : 135 °C 4000 h	210
		ZSU-A : 125 °C 4000 h	212
		ZE-A : 145 °C 2000 h	214
		ZF-A : 150 °C 1000 h	216

Safety and Legal Matters to Be Observed

Product specifications and applications

- Please be advised that this product and product specifications are subject to change without notice for improvement purposes. Therefore, please request and confirm the latest delivery specifications that explain the specifications in detail before the final design, or purchase or use of the product, regardless of the application. In addition, do not use this product in any way that deviates from the contents of the company's delivery specifications.
- Unless otherwise specified in this catalog or the product specifications, this product is intended for use in general electronic equipment (AV products, home appliances, commercial equipment, office equipment, information and communication equipment, etc.).
When this product is used for the following special cases, the specification document suited to each application shall be signed/sealed (with Panasonic Industry and the user) in advance..These include applications requiring special quality and reliability, wherein their failures or malfunctions may directly threaten human life or cause harm to the human body (e.g.: space/aircraft equipment, transportation/traffic equipment, combustion equipment, medical equipment, disaster prevention/crime prevention equipment, safety equipment, etc.).

Safety design and product evaluation

- Please ensure safety through protection circuits, redundant circuits, etc., in the customer's system design so that a defect in our company's product will not endanger human life or cause other serious damage.
- This catalog shows the quality and performance of individual parts. The durability of parts varies depending on the usage environment and conditions. Therefore, please ensure to evaluate and confirm the state of each part after it has been mounted in your product in the actual operating environment before use.
If you have any doubts about the safety of this product, then please notify us immediately, and be sure to conduct a technical review including the above protection circuits and redundant circuits at your company.

Laws / Regulations / Intellectual property

- The transportation of dangerous goods as designated by UN numbers, UN classifications, etc., does not apply to this product. In addition, when exporting products, product specifications, and technical information described in this catalog, please comply with the laws and regulations of the countries to which the products are exported, especially those concerning security export control.
- Each model of this product complies with the RoHS Directive (Restriction of the use of hazardous substances in electrical and electronic equipment) (2011/65/EU and (EU) 2015/863). The date of compliance with the RoHS Directive and REACH Regulation varies depending on the product model.
Further, if you are using product models in stock and are not sure whether or not they comply with the RoHS Directive or REACH Regulation, please contact us by selecting "Sales Inquiry" from the inquiry form.
- During the manufacturing process of this product and any of its components and materials to be used, Panasonic Industry does not intentionally use ozone-depleting substances stipulated in the Montreal Protocol and specific bromine-based flame retardants such as PBBs (Poly-Brominated Biphenyls) / PBDEs (Poly-Brominated Diphenyl Ethers). In addition, the materials used in this product are all listed as existing chemical substances based on the Act on the Regulation of Manufacture and Evaluation of Chemical Substances.
- With regard to the disposal of this product, please confirm the disposal method in each country and region where it is incorporated into your company's product and used.
- The technical information contained in this catalog is intended to show only typical operation and application circuit examples of this product. This catalog does not guarantee that such information does not infringe upon the intellectual property rights of Panasonic Industry or any third party, nor imply that the license of such rights has been granted.
- Design, materials, or process related to technical owned by Panasonic Industry are subject to change without notice.

Panasonic Industry will assume no liability whatsoever if the use of our company's products deviates from the contents of this catalog or does not comply with the precautions. Please be advised of these restrictions.

Conductive polymer capacitor of Panasonic Industry

SP-Cap

Conductive Polymer Aluminum Electrolytic Capacitors (Stack Type)

- Super Low ESR
- Low profile
- Large capacitance

POSCAP

Conductive Polymer Tantalum Solid Capacitors (Sintered Type)

- Low ESR
- Small size
- Large capacitance

OS-CON

Conductive Polymer Aluminum Solid Capacitors (Wound Type)

- Low ESR
- High voltage
- Large capacitance

Hybrid

Conductive Polymer Hybrid Aluminum Electrolytic Capacitors (Wound Type)
Conductive Polymer + Electrolyte

- Low ESR
- High voltage
- High reliability

Characteristics Portfolio

Full coverage of the capacitor conductive market

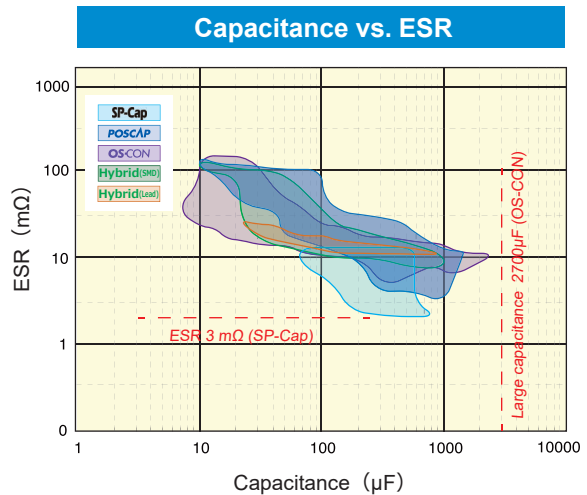
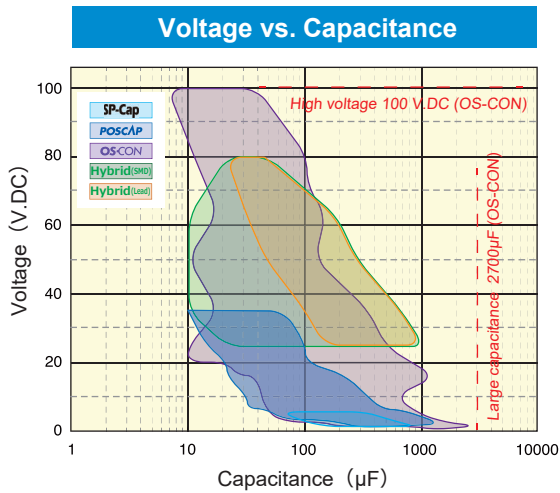

Basic structure

SP-Cap

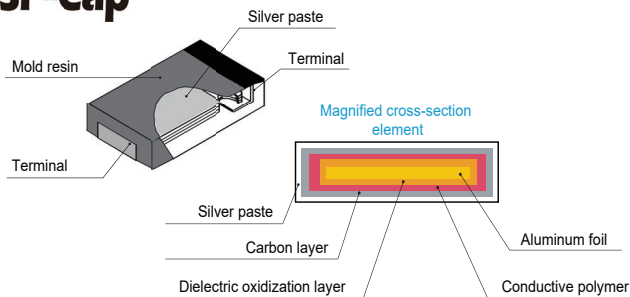

POSCAP

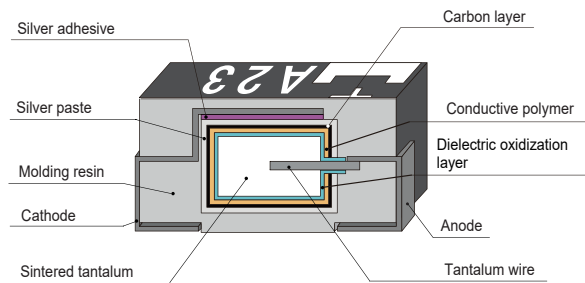

OS-CON Hybrid

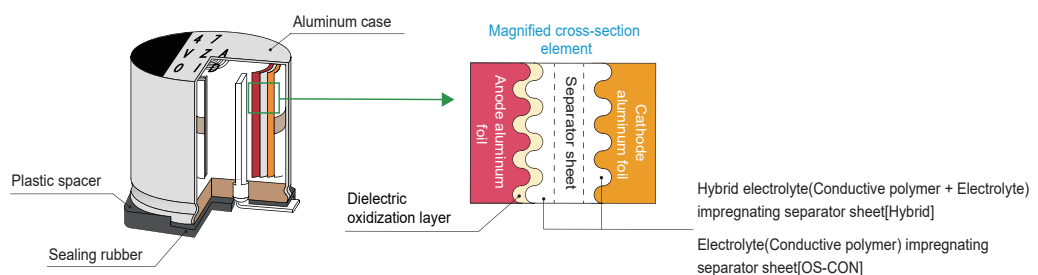

Examples of common use case four conductive products

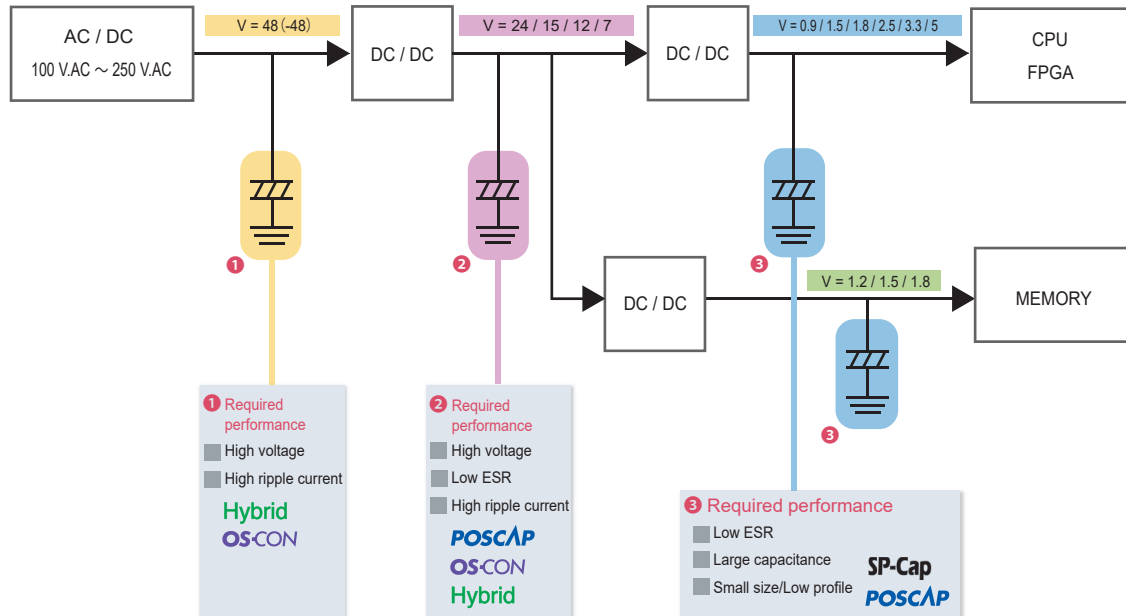

• You can select the optimal article from "size form and total cost" etc. besides an electrical property.

Application

	SP-Cap	POSCAP	OS-CON	Hybrid
Laptop computer	•	•		
Desktop computer			•	•
Audio/Visual	•	•	•	•
Server	•	•	•	•
Communications infrastructure	•	•	•	•
SSD, HDD		•		
Automotive		• [※]		•
Home appliance			•	•
Industry	Industrial equipment	•	•	•
	Industrial robot		•	•
	Drone etc.	•	•	

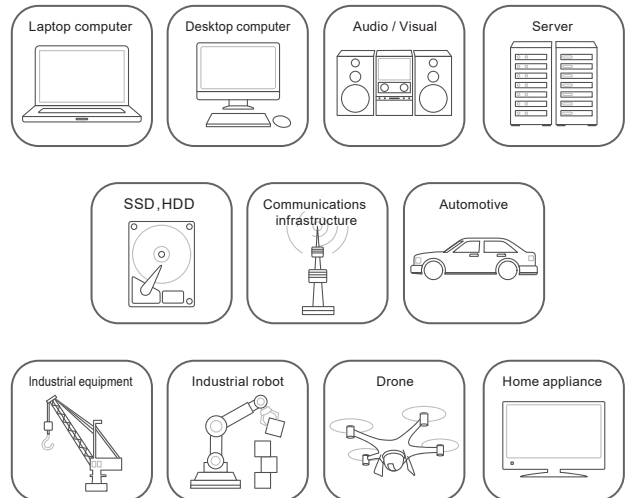

※ This product is not intended for use in any driving application or any other critical functions that affect passenger safety (e.g. Powertrain, ABS, Engine ECU, Airbag, etc.)
If the intended use of TA/TV series products is for use in other automotive related applications, please contact our sales team.
All requests are subject to approval.

• Main market

Conductive Polymer Aluminum Electrolytic Capacitors

SP-Cap™

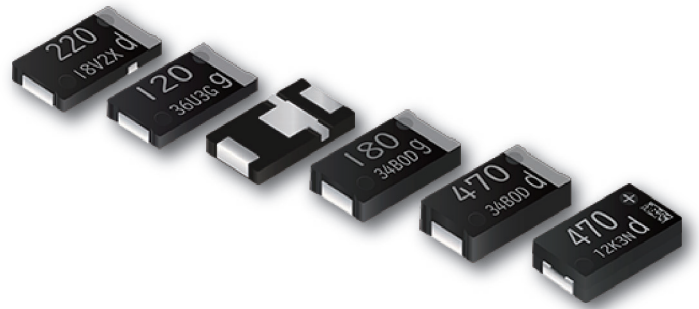

INDEX

Application Guidelines (SP-Cap)	P5
Line-up / Diagram	P8
Voltage - Capacitance table	P10
Explanation of part numbers	P12
Mounting / Packing specifications	P13
Each series	P15
Replacement list for “Not recommended for new design”	P44

Applications

Main market

Laptop computer

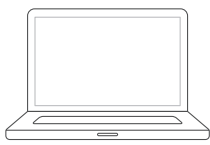

Server



Communications infrastructure

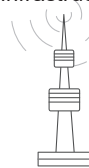

Industrial equipment

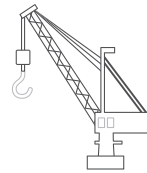

Audio / Visual

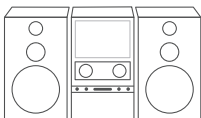

Smart phone
Tablet



Drone



Matters to Be Observed When Using This Product

(Conductive Polymer Aluminum Electrolytic Capacitors / SP-Cap)

Intended use

SP-Cap (all series) does not meet the quality standards required for automotive-related equipment. Therefore, we are unable to support compliance with related standards (such as AEC-Q200, PPAP, etc.). We shall not be responsible for any issues arising from the use of these products in such applications.

Use environments and cleaning conditions

■ This product (capacitor) is intended for standard general-purpose use in electronic equipment, and is not designed for use in the specific environments described below. Using the product in such specific environments or service conditions, therefore, may affect the performance of the product.

Please check with us about the performance and reliability of the product first before using the product.

- (1) Used in liquid, such as water, oil, chemicals, and organic solvents.
- (2) Used in a place exposed to direct sunlight, an outdoor place with no shielding, or a dusty place.
- (3) Used in a wet place (dew concentration on a resistor, water leakage, etc.), a place exposed to sea breeze, or a place filled with a corrosive gas, such as Cl₂, H₂S, NH₃, SO₂, or NO_x.
- (4) Used in an environment where static electricity and electromagnetic waves are strong.
- (5) The product is located close to a heating component or a flammable material, such as a vinyl cable, is placed near the product.
- (6) The product is used sealed with a resin, etc.
- (7) Solder flux of the soldered product is cleansed with a solvent, water, and a water-soluble cleaner.
(Be careful with water soluble solder flux.)
- (8) Used in an environment where an acidic or alkali atmosphere is present.
- (9) Used in an environment where excessive vibration or impact is applied to the product.
- (10) Used under a low atmospheric pressure condition or depressurized condition.

■ After soldering, clean the circuit board at a temperature of 60 °C or lower for 5 minutes or less. However, ensure to thoroughly rinse and dry it (at 100 °C for 20 minutes or less). The applicable solvents are as follows.

Pine Alpha ST-100S, Clean-thru 750H/750L/710M, Aqua Cleaner 210SEP, Sunelec B-12, DK be-clear CW-5790, Techno Cleaner 219, Cold Cleaner P3-375, Terpene Cleaner EC-7R, Techno Care FRW-17/FRW-1/FRV-1, AXREL 32, IPA (isopropyl alcohol)

- (1) Please contact us in advance for the use of cleaning agents other than those listed above and water except pure water.
- (2) Avoid using ozone-depleting substances as cleaning agents to protect the global environment.
- (3) Performing ultrasonic cleaning may cause terminal disconnection, which requires prior evaluation.

■ Do not apply strong force to this product. Doing so may adversely affect mounting by causing the deformation of electrode terminals or other defects.

In addition, the application of strong force may also lead to short circuits, disconnection, increased leakage currents, and damage to the outer packaging of the product. Do not hold the body of the product or apply force even after it is attached to the circuit board.

■ When the capacitor is used in a circuit where an impact voltage is applied or a high voltage is applied in a short period (transient phenomenon) or a high pulse voltage is applied, make sure to use the capacitor at a voltage equal to or lower than its rated voltage.

Response to anomalies and handling conditions

If this product heats up abnormally, then smoke may be generated from the exterior resin. In this case, immediately turn off the main power of the equipment and stop using it. Also, keep your face and hands away from the product as it may become hot and cause burns.

Reliability and product life

- Most of the failure modes are "short circuits" or "increased leakage currents." The main causes of failures are thermal stress, electrical stress, and mechanical stress due to reflow and operating temperature environments. Even within the range of the specified use conditions, it is possible to reduce the failure rate by mitigating the operating conditions such as the temperature and voltage. Therefore, please design equipment with a sufficient margin.
- The estimated failure rate is 8.2 Fit or less (estimated at 105 °C when the rated voltage is applied) based on data obtained from the company's reliability test, while the estimated market failure rate is 0.13 Fit or less (estimated at c = 0 and a confidence level of 60 %).

Circuit design and circuit board design

- Do not use this product in high-impedance voltage holding circuits, coupling circuits, time constant circuits, and those that are significantly affected by leakage currents. Also, do not connect two or more units of this product in series.
- Applying overvoltage that exceeds the rated voltage specified in the specifications or reverse voltage to this product may cause an increase in leakage currents or short circuits.
Applied voltage refers to the voltage value applied to a circuit, including the effects of the peak values of ripple voltage and transient instantaneous voltage, and does not only indicate the steady line voltage value. Design circuits so that the peak voltage does not exceed the specified voltage.
Use this product by regulating the operating voltage to keep it lower than or equal to the rated voltage even for impulse voltage circuits, applications involving transient phenomena where a considerably high voltage is applied in a short time, and cases where high pulse voltages are applied.
- Keep the operating temperature within the range stipulated in the specifications. Design your equipment in consideration of not only the ambient temperature where the equipment is placed and its internal temperature, but also the radiant heat from heating elements (power transistors, resistors, etc.) inside the equipment, and the temperature of this product, including self-heating due to ripple current.
- Regulate the ripple current within the rated range specified in the specifications when using the product.
Excessive ripple current causes increased leakage currents and short circuit failures due to self-heating.
Even if the ripple current is within the rated range, prevent the ripple voltage from applying overvoltage or reverse voltage to the product.
- The ESR rating is the value at the time of shipment from the factory. The ESR value may vary depending on the customer's usage conditions.
- Leakage currents may increase after reflow soldering, and also under no-load conditions at high temperatures, in high temperature and high humidity environments, or with sudden temperature changes, even if the operating environment is within the specified range. However, in most cases, SP-Cap reduces leakage currents due to its self-recovery action when voltage is applied.
- Insulate the circuit board surface directly under the mounting area of this product. Lay out your circuit board by defining the dimensions of lands with reference to the mounting specifications stipulated in the requirements.
The dimensions of the actual design circuit should enable the optimum mounting depending on conditions such as the circuit board, parts, and reflow.

Mounting and storage conditions

- Check the rating (capacitance, rated voltage), polarity, and land dimensions of this product before mounting it on the circuit board. When using mounting equipment, large pressure applied during mounting may lead to an increase in leakage currents, short circuits, disconnection, or falling off from the circuit board.
- Do not use flow and dip soldering. Reflow soldering can be used with the following methods. Please refer to the mounting specifications for the recommended conditions for using the atmospheric heat conduction method. Please contact us for the recommended conditions for using the VPS method.
 - (1) Atmospheric heat conduction method (infrared ray/hot-air system)
 - (2) VPS method (target series: CX, CT, SX, ST, GX, LX, LT, and HX)
- Soldering must be performed at a temperature of 350 °C or lower at the tip of the soldering iron and within an operation time of 10 seconds, without applying excessive force to the product.
In addition, do not remove this product for reuse once it is mounted. Soldering outside the specified conditions can cause short circuit failures, an increase in ESR, and other defects.
- Store this product in an environment with a temperature ranging from 5 °C to 30 °C and a humidity of 70% or lower by using a moisture barrier bag. The storage period before opening the moisture barrier bag is two years after manufacture, and after opening the bag is seven days. If these conditions are exceeded, then the outer package may be damaged due to thermal stress during mounting caused by moisture absorption by the package.
After opening the bag, use up all pieces of this product within the specified storage period.
- This product is composed of various metals and resins, requiring disposal as industrial waste.

Reference information

Guidelines

The matters to be observed when using this product cite the technical report issued by the Japan Electronics and Information Technology Industries Association, and EIAJ RCR-2367D issued in October 2017, "Safety application guide for fixed aluminum electrolytic capacitors for use in electronic equipment." Please refer to the above technical report for details.

Intellectual property

Panasonic Group provides customers with safe products and services. We are also making great efforts to protect our intellectual property rights for Panasonic Group products. Typical patents related to this product are as follows.

[U.S. patent]

USP Nos. 7136276, 7787234

Line up

■ Long life products

Series	Part No.	Feature	Low profile	Low ESR	Low ESL	Large cap.	High temp.	Long life	High voltage	Category temperature (°C)	Rated voltage (V)	ESR (mΩ)	Capacitance (μF)	Size (mm)
														L x W
														7.3x4.3
														H
JX	EEFJX---	Guaranteed at 125 °C 3000 h		●				●	●	-55 to 125	2 to 6.3	3 to 15	120 to 470	1.9
KX	EEFKX---	Guaranteed at 125 °C 5500 h		●				●	●	-55 to 125	2 to 6.3	3 to 15	120 to 470	1.9
TX	EEFTX---	Guaranteed at 135 °C 5500 h		●				●	●	-55 to 135	2 to 6.3	3 to 15	120 to 470	1.9
JZ	EEFJZ---	Guaranteed at 125 °C 3000 h Large capacitance		●		●	●	●		-55 to 125	2	3 to 9	560	2.2
KZ	EEFKZ---	Guaranteed at 125 °C 5500 h Large capacitance		●		●	●	●		-55 to 125	2	3 to 9	560	2.2
TZ	EEFTZ---	Guaranteed at 135 °C 5500 h Large capacitance		●		●	●	●		-55 to 135	2	3 to 9	560	2.2

■ Standard products

Series	Part No.	Feature	Low profile	Low ESR	Low ESL	Large cap.	High temp.	Long life	High voltage	Category temperature (°C)	Rated voltage (V)	ESR (mΩ)	Capacitance (μF)	Size (mm)
														L x W
														7.3x4.3
														H
CX	EEFCX---	Standard							●	-55 to 105	2 to 35	12 to 40	15 to 560	1.9
CT	EEFCT---	Low profile	●						●	-55 to 105	4 to 35	15 to 40	15 to 180	1.4
CS	EEFCS---	Low profile	●						●	-55 to 105	4 to 35	15 to 40	10 to 120	1.1
SX	EEFSX---	Low ESR		●						-55 to 105	2 to 6.3	4.5 to 9	82 to 560	1.9
GX	EEFGX---	Super low ESR High ripple current		●						-55 to 105	2, 2.5	3	330 to 560	1.9
LX	EEFLX---	Low ESR · Low ESL		●	●					-55 to 105	2, 2.5	4.5 to 6	330 to 560	1.9
ST	EEFST---	Low profile · Low ESR	●	●						-55 to 105	2, 2.5	6	270 to 330	1.4
LT	EEFLT---	Low profile Low ESR · Low ESL	●	●	●					-55 to 105	2, 2.5	6	270 to 330	1.4
SS	EEFSS---	Low profile · Low ESR	●	●						-55 to 105	2, 2.5	6	180 to 220	1.1
LS	EEFLS---	Low profile Low ESR · Low ESL	●	●	●					-55 to 105	2, 2.5	6	180 to 220	1.1
SR	EEFSR---	Low profile (1.0 mm max.) Low ESR	●	●						-55 to 105	2 to 6.3	4.5 to 9	68 to 220	1.0max.
LR	EEFLR---	Low profile (1.0 mm max.) Low ESR · Low ESL	●	●	●					-55 to 105	2 to 6.3	4.5 to 9	68 to 220	1.0max.
GY	EEFGY---	Super low ESR / High ripple current / Height 3.0 mm max.		●		●				-55 to 105	2, 2.5	3	680 to 820	2.8
CY	ECGCY---	Guaranteed at 85 °C Height 3.0 mm max.				●				-55 to 85	4, 6.3	15	330 to 470	2.8
SY	ECGSY---	Low ESR / Guaranteed at 85 °C / Height 3.0 mm max.		●		●				-55 to 85	4, 6.3	9	330 to 470	2.8
HX	EEFHX---	Guaranteed at 125 °C					●	●		-55 to 125	2 to 25	4.5 to 40	15 to 470	1.9

• 2 to 6.3 V : On sale
 • 10 to 35 V : Not recommended for new design
 ※ Click [here](#) for Replacement (10 to 35 V)

Series flow chart

■ Long life products

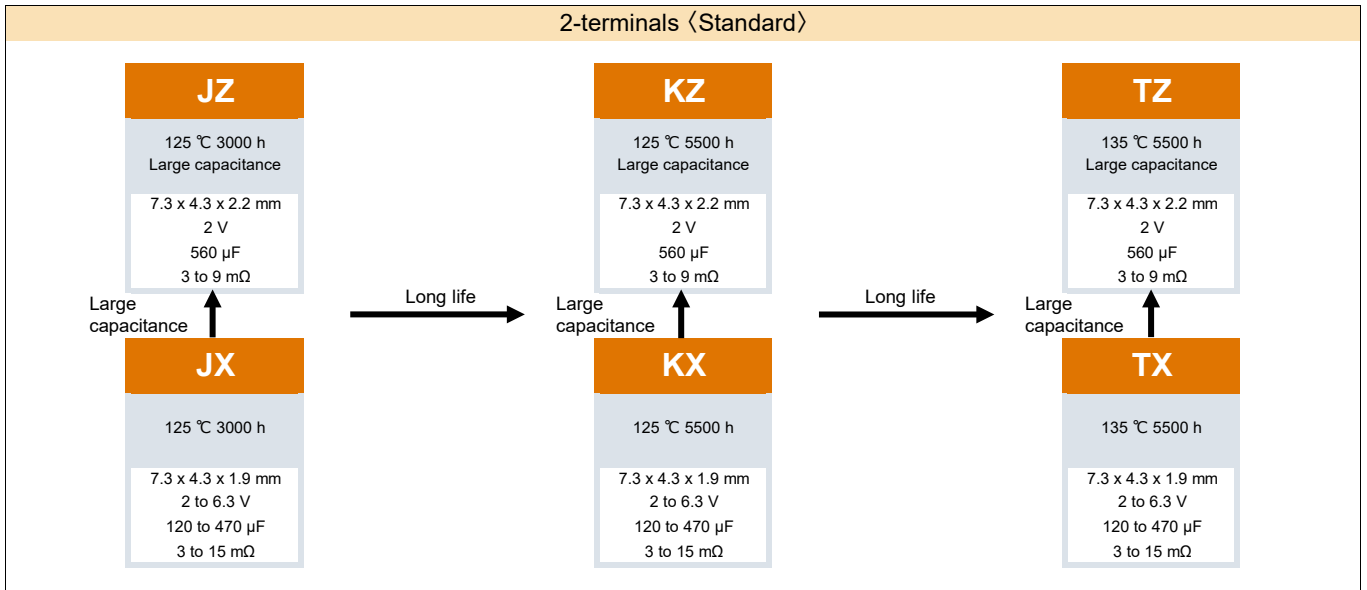

■ Standard products

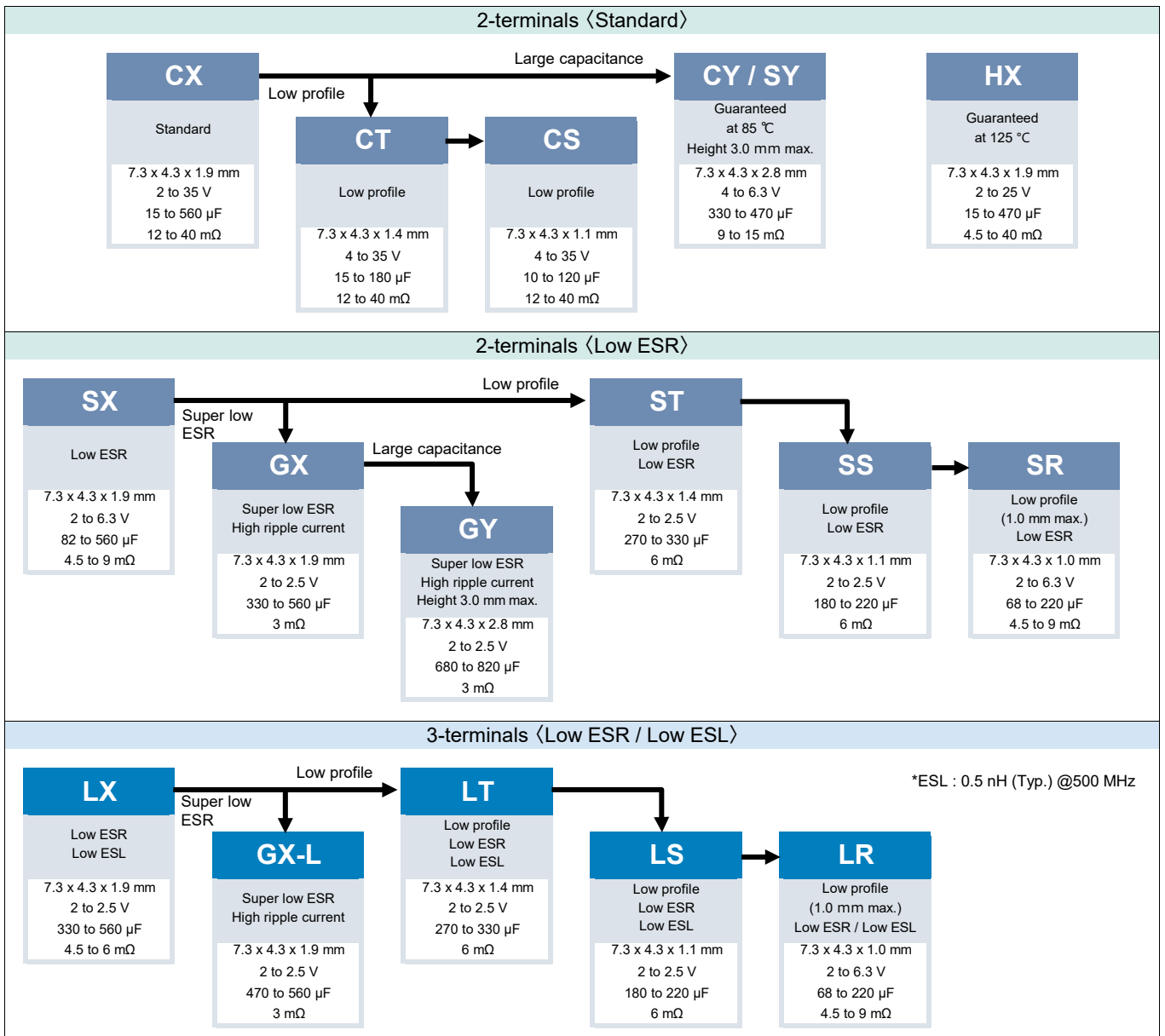

Voltage - Capacitance table (Vol. : 2.0 to 6.3 V / Cap. : 10 to 120 μF)

Series
(ESR mΩ)

V	μF	10	15	22	33	47	56	68	82	100	120
2.0											
2.5											
4.0									SX (9)	SX (9)	CS (15)
											SR (9)
											LR (9)
6.3								CS (15)		CT (15)	CX (15)
								SR (9)		CX (15)	SX (7)
								LR (9)			JX (15)
											KX (15)
											TX (15)

Size list LxWxH (mm)

SR, LR	7.3 x 4.3 x 1.0 max.	CX, GX, LX, LX, JX, KX, TX, HX	7.3 x 4.3 x 1.9
SS, LS, CS	7.3 x 4.3 x 1.1	JZ, KZ, TZ	7.3 x 4.3 x 2.2
CT, ST, LT	7.3 x 4.3 x 1.4	CY, SY	7.3 x 4.3 x 2.8

Voltage - Capacitance table (Vol. : 2.0 to 6.3 V / Cap. : 150 to 820 μ F)

Series
(ESR m Ω)

V	μ F	150	180	220	270	330	390	470	560	680	820
2.0			SX (9)	CX (15)	CX (12)	CX (15,12)	CX (15)	CX (15)	CX (15)		GY (3)
				SX (9)	SX (9,6,4.5)	SX (9,6,4.5)	SX (9,6,4.5)	SX (9,6,4.5)	SX (4.5)		
				SR (6,4.5)		GX (3)		GX (3)	GX (3)		
				LR (6,4.5)		LX (6,4.5)		GX-L (3)	GX-L (3)		
				SS (6)		ST (6)		LX (6,4.5)	LX (6,4.5)		
				LS (6)		LT (6)		JX (9,4.5,3)	JZ (9,4.5,3)		
						JX (9)		KX (9,4.5,3)	KZ (9,4.5,3)		
						KX (9)		HX (15,9,6,4.5)	TZ (9,4.5,3)		
						TX (9)		TX (9,4.5,3)			
2.5		SX (9)	SX (9)	CX (15)	SX (7)	CX (15)	CX (15)	CX (15)		GY (3)	
			SR (6,4.5)	SX (9,7)	ST (6)	SX (9,6)	SX (9,6,4.5)	SX (9,6,4.5)			
			LR (6,4.5)	JX (9)	LT (6)	GX (3)	JX (9,4.5,3)	GX (3)			
			SS (6)	KX (9)		LX (6,4.5)	KX (9,4.5,3)	GX-L (3)			
			LS (6)	TX (9)		JX (9)	TX (9,4.5,3)	LX (6,4.5)			
						KX (9)		JX (9,4.5,3)			
						HX (15,9,6,4.5)		KX (9,4.5,3)			
						TX (9)		HX (15,9,6,4.5)			
4.0		CX (15)	CT (15)	CX (15, 12)	CX (15)	CX (15)		CY (15)			
		SX (9,7)	CX (15,12)	SX (9)	SX (9)	SX (9,6)		SY (15)			
		JX (15)	SX (9)	JX (15)							
		KX (15)	JX (15)	KX (15)							
		TX (15)	KX (15)	TX (15)							
			TX (15)								
6.3		CX (15,12)	CX (15)	CX (15)		CY (15)					
		SX (9)	SX (9)	SX (9)		SY (9)					
		JX (15)									
		KX (15)									
		TX (15)									

Size list LxWxH (mm)

SR, LR	7.3 x 4.3 x 1.0 max.	CX, GX, LX, LX, JX, KX, TX, HX	7.3 x 4.3 x 1.9
SS, LS, CS	7.3 x 4.3 x 1.1	JZ, KZ, TZ	7.3 x 4.3 x 2.2
CT, ST, LT	7.3 x 4.3 x 1.4	CY, SY	7.3 x 4.3 x 2.8

Explanation of part numbers

◇ Part number system

EEF		CX		0E		471		R	
Product classification 3 figures		Series 2 figures		Voltage code 2 figures		Capacitance code 3 figures		Special code 1 to 2 figures	
Series	Product classification	Series	Code	Voltage (V)	Code	Cap. (μF)	Code		
JX	EEF	JX	JX	2	0D	10	100		
KX		KX	KX	2.5	0E	15	150		
TX		TX	TX	4	0G	22	220		
JZ		JZ	JZ	6.3	0J	33	330		
KZ		KZ	KZ	10	1A	47	470		
TZ		TZ	TZ	16	1C	56	560		
CX		CX	CX	20	1D	68	680		
CT		CT	CT	25	1E	100	101		
CS		CS	CS	35	1V	120	121		
SX		SX	SX			150	151		
LX		LX	LX			180	181		
GX		GX	GX			220	221		
ST		ST	ST			270	271		
LT		LT	LT			330	331		
SS		SS	SS			390	391		
LS		LS	LS			470	471		
SR		SR	SR			560	561		
LR		LR	LR			680	681		
GY	GY	GY			820	821			
CY	ECG	CY	CY						
SY		SY	SY						
HX	EEF	HX	HX						

Height (mm)	Series	Special code	ESR (mΩ max.)	Terminals	
				2	3
1.9 ± 0.1	JX KX TX	RF	15	○	
		RE	9	○	
		RC	4.5	○	
		RB	3	○	
2.2 ± 0.1	JZ KZ TZ	RE	9	○	
		RC	4.5	○	
		RB	3	○	
1.9 ± 0.1	CX	R	15 (to 6.3 V), 40 (10 V to 35 V)	○	
		XR	12	○	
	SX	ER	9	○	
		E7	7	○	
		XE	6	○	
	GX	R	3	○	
		L	3		○
	LX	R	6		○
		R4	4.5		○
		R	15 (to 2.5 V), 40 (10 V to 25 V)	○	
R9		9	○		
HX	R6	6	○		
	R4	4.5	○		
	R4	4.5	○		
1.4 ± 0.1	CT ST LT	R	15 (to 6.3 V), 40 (10 V to 35 V)	○	
		R	6	○	
		R	6		○
1.1 ± 0.1	CS SS LS	R	15 (to 6.3 V), 40 (10 V to 35 V)	○	
		R	6	○	
		R	6		○
1.0 (max.)	SR	R	6 (to 2.5 V), 9 (4 V to 6.3 V)	○	
		R4	4.5	○	
	LR	R	6 (to 2.5 V), 9 (4 V to 6.3 V)		○
		R4	4.5		○
2.8 ± 0.2	GY CY SY	R	3	○	
		R	15	○	
		R	9	○	

Mounting specification

● Recommendable reflow soldering

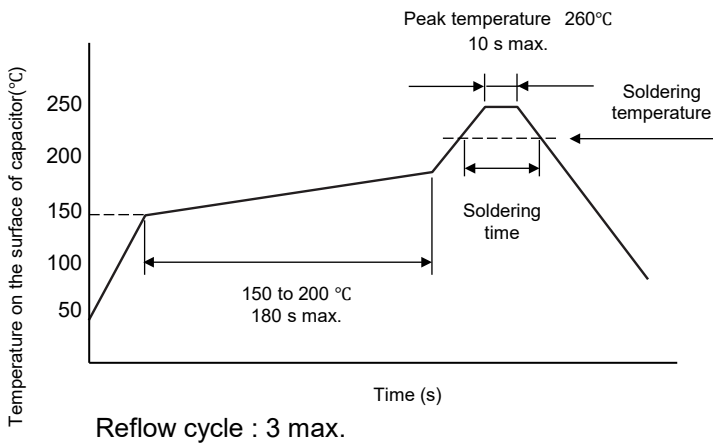

Soldering temperature and soldering time

Temperature	Time
≥ 255°C	30 s max.
≥ 230°C	130 s max.
≥ 217°C	150 s max.

SP-Cap recommended profile condition of the IPC/J-STD-020F standard

● Typical land pattern

□ 2-terminals

For standard terminal (C*, S*, G*, J*, K*, T*, HX series)

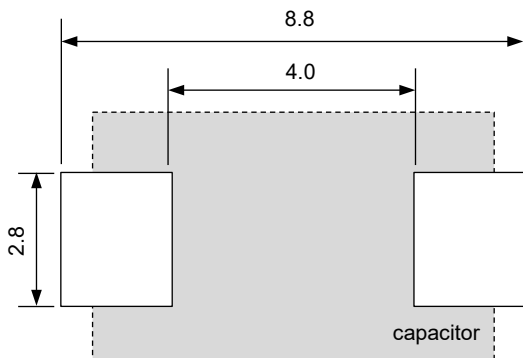

Unit:mm

□ 3-terminals

For low ESL terminal (L*, GX-L series)

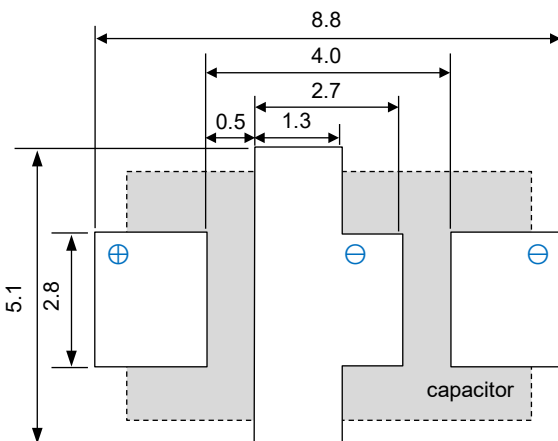

〈VIA〉

For low ESL terminal (L*, GX-L series)

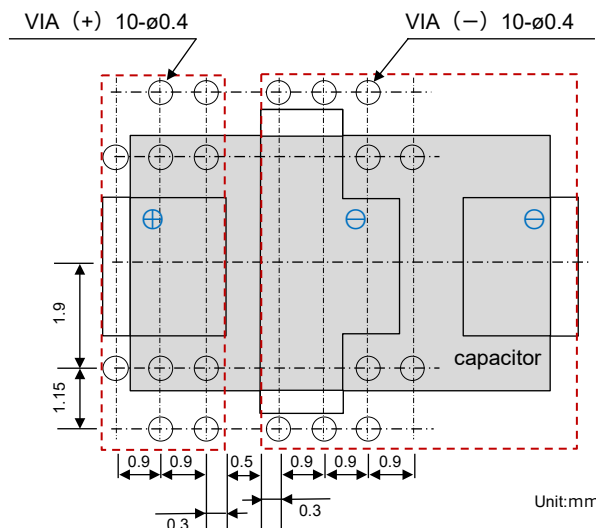

Unit:mm

Packaging specifications

● Reel dimensions

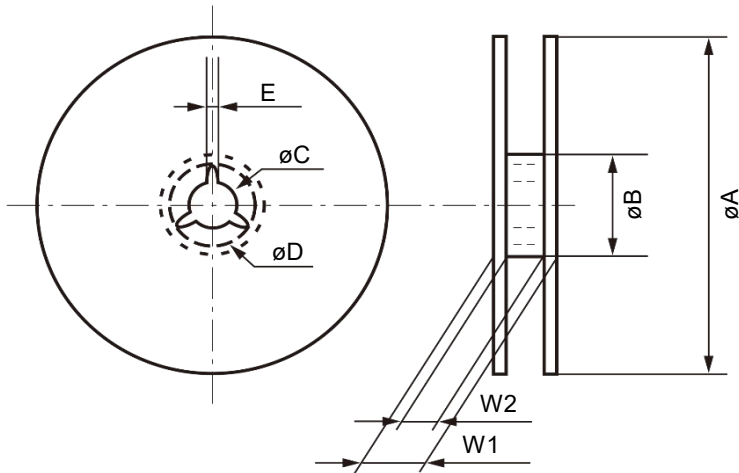

Unit:mm

Reel	øA	øB	øC	øD	E	W1	W2
ø330	330 ± 2	80 ± 1	13 ± 0.2	21 ± 0.8	2 ± 0.5	17.5 ± 1	13.5 ± 1

● Embossed tapping
(12mm tape)

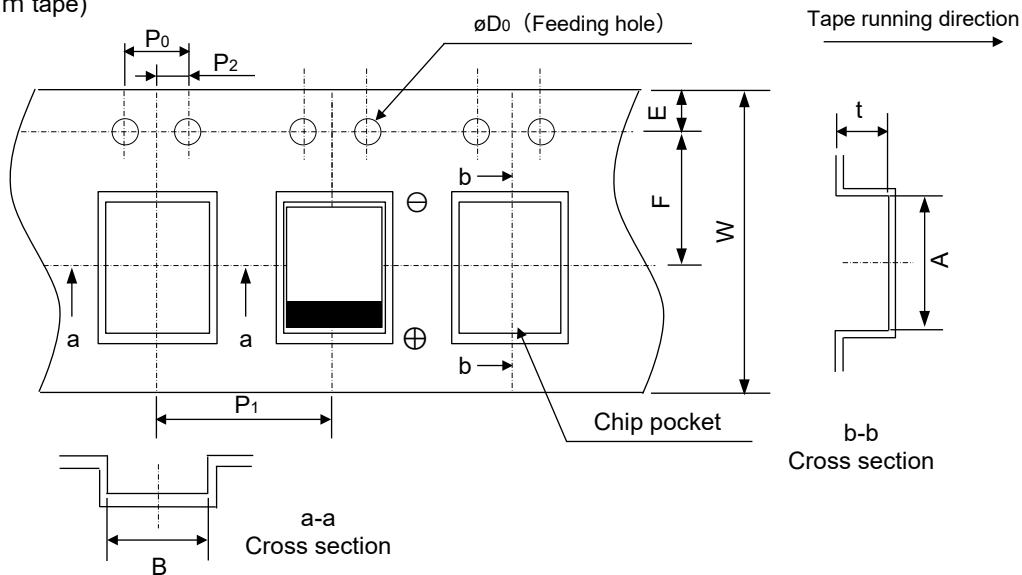

Unit:mm

A	B	W	F	E	P1	P2	P0
7.6 ± 0.2	4.5 ± 0.2	12 ± 0.3	5.5 ± 0.1	1.75 ± 0.1	8.0 ± 0.1	2.0 ± 0.1	4.0 ± 0.1

øD ₀	Upper row : Product height / Lower berth : t			
	to 1.1	1.4 to 1.9	2.2	2.8
1.5 ^{+0.1} ₀	1.5 ± 0.2	2.4 ± 0.2	2.9 ± 0.2	3.5 ± 0.2

● Packaging box dimensions

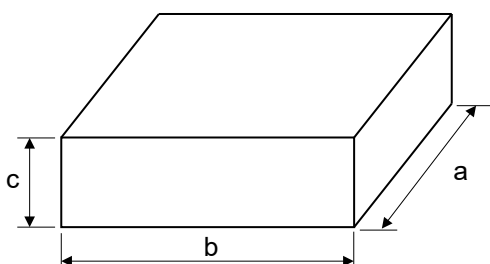

Unit:mm

Reel	a	b	c
ø330	400 max.	400 max.	135 max.

**Conductive Polymer Aluminum
Electrolytic Capacitors**
Surface Mount Type

JX series [High temperature long life product]

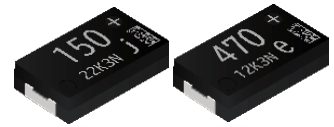

Notice: This product is not intended for use in automotive applications.

Features

- Endurance 125 °C 3000 h
- Damp heat 85°C 85% 1000 h
- Low ESR (3 to 15 mΩ)
- RoHS compliance, Halogen free

Specifications

Series	JX			
Category temp. range	-55 °C to +125 °C			
Rated voltage range	2.0 V to 6.3 V			
Category voltage range	1.6 V, 2.0 V, 3.2 V, 5.0 V			
Rated cap. range	120 μF to 470 μF			
Capacitance tolerance	±20 % (120 Hz / +20 °C)			
DC leakage current	I ≤ 0.1 CV (μA) 2 minutes			
Dissipation factor (tan δ)	≤ 0.1 (120 Hz / + 20 °C)			
Surge voltage (V)	Rated voltage × 1.25 (15 °C to 35 °C)			
Endurance	+125 °C 3000 h, category voltage applied			
	Capacitance change	Within ±20 % of the initial value		
	Dissipation factor (tan δ)	≤ 2 times of the initial limit		
	DC leakage current	≤ 3 times of the initial limit		
Damp heat (Steady state)	+85 °C, 85 % RH, 1000 h, No-applied voltage			
	Capacitance change of initial measured value	2.0 V, 2.5 V	4.0 V	6.3 V
		+70 %, -20 %	+60 %, -20 %	+50 %, -20 %
	Dissipation factor (tan δ)	≤ 2 times of the initial limit		
DC leakage current	≤ 5 times of the initial limit			

Marking

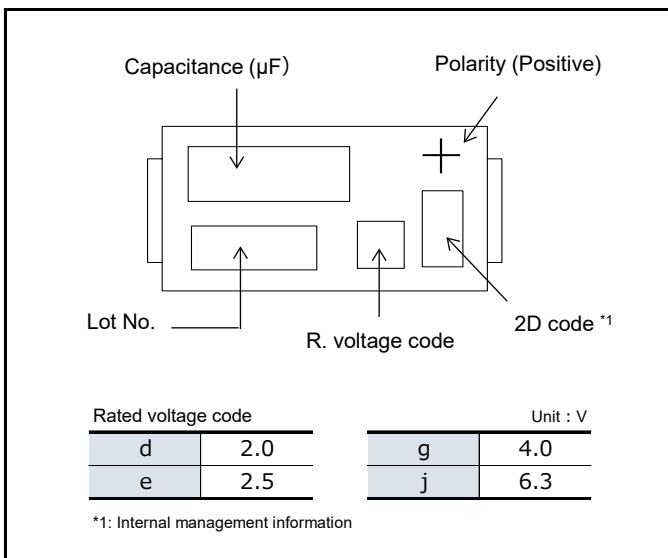

Dimensions (not to scale)

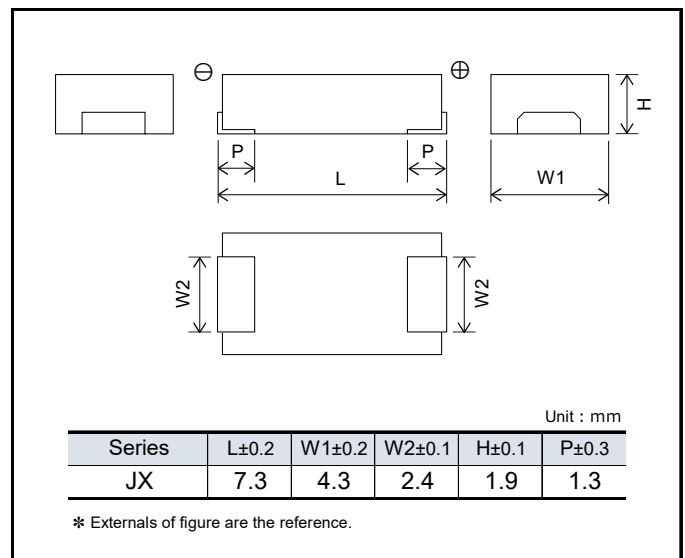

Explanation of part numbers

◇ Part number system e.g.: EEFJX0D331RE

EEF		JX		0D		331				RE	
Series	Product classification	Series	Code	Rated Voltage (V)	Code	Capacitance (μF)	Code	Capacitance (μF)	Code	ESR (mΩ)	Special code
JX	EEF	JX	JX	2.0	0D	120	121	330	331	3	RB
				2.5	0E	150	151	390	391	4.5	RC
				4.0	0G	180	181	470	471	9	RE
				6.3	0J	220	221			15	RF

Characteristics list

Series	Rated voltage [105 °C] (V)	Category voltage [125 °C] (V)	Capacitance (μF)	Case size (mm)			Specification		Part number	Min. Packaging Qty (pcs)
				L	W	H	Ripple current* ¹ (mA rms)	ESR* ² (mΩ max.)		
JX	2.0	1.6	330	7.3	4.3	1.9	6300	9	EEFJX0D331RE	3500
				7.3	4.3	1.9	6300	9	EEFJX0D471RE	3500
			470	7.3	4.3	1.9	8500	4.5	EEFJX0D471RC	3500
				7.3	4.3	1.9	10200	3	EEFJX0D471RB	3500
	2.5	2.0	220	7.3	4.3	1.9	6300	9	EEFJX0E221RE	3500
				7.3	4.3	1.9	6300	9	EEFJX0E331RE	3500
			390	7.3	4.3	1.9	6300	9	EEFJX0E391RE	3500
				7.3	4.3	1.9	8500	4.5	EEFJX0E391RC	3500
			470	7.3	4.3	1.9	10200	3	EEFJX0E391RB	3500
				7.3	4.3	1.9	6300	9	EEFJX0E471RE	3500
				7.3	4.3	1.9	8500	4.5	EEFJX0E471RC	3500
				7.3	4.3	1.9	10200	3	EEFJX0E471RB	3500
	4.0	3.2	150	7.3	4.3	1.9	5100	15	EEFJX0G151RF	3500
			180	7.3	4.3	1.9	5100	15	EEFJX0G181RF	3500
			220	7.3	4.3	1.9	5100	15	EEFJX0G221RF	3500
	6.3	5.0	120	7.3	4.3	1.9	5100	15	EEFJX0J121RF	3500
			150	7.3	4.3	1.9	5100	15	EEFJX0J151RF	3500

*1: Ripple current (100 kHz / +45 °C)

*2: ESR (100 kHz / +20 °C)

◆ Please refer to each page in this catalog for "Reflow conditions" and "Taping specifications".

Temperature coefficient of ripple current

Temperature		T ≤ 45 °C	45 °C < T ≤ 85 °C	85 °C < T ≤ 125 °C
2.0 V to 6.3 V	Coefficient	1.0	0.7	0.25

◆ Ripple current should be controlled so that surface temperature of capacitor does not exceed the category temperature.

Conductive Polymer Aluminum Electrolytic Capacitors

Surface Mount Type

KX series [High temperature long life product]

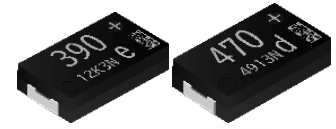

Notice: This product is not intended for use in automotive applications.

Features

- Endurance 125 °C 5500 h
- Damp heat 85°C 85% 1000 h
- Low ESR (3 ~ 15 mΩ max.)
- RoHS compliance, Halogen free

Specifications

Series	KX			
Category temp. range	-55 °C to +125 °C			
Rated voltage range	2.0 V to 6.3 V			
Category voltage range	1.6 V, 2.0 V, 3.2 V, 5.0 V			
Rated cap. range	120 μF to 470 μF			
Capacitance tolerance	±20 % (120 Hz / +20 °C)			
DC leakage current	I ≤ 0.1 CV (μA) 2 minutes			
Dissipation factor (tan δ)	≤ 0.1 (120 Hz / + 20 °C)			
Surge voltage (V)	Rated voltage × 1.25 (15 °C to 35 °C)			
Endurance	+125 °C 5500 h, category voltage applied			
	Capacitance change	Within ±20 % of the initial value		
	Dissipation factor (tan δ)	≤ 2 times of the initial limit		
	DC leakage current	≤ 3 times of the initial limit		
Damp heat (Steady state)	+85 °C, 85 % RH, 1000 h, No-applied voltage			
	Capacitance change of initial measured value	2.0 V, 2.5 V	4.0 V	6.3 V
		+70 %, -20 %	+60 %, -20 %	+50 %, -20 %
	Dissipation factor (tan δ)	≤ 2 times of the initial limit		
DC leakage current	≤ 5 times of the initial limit			

Marking

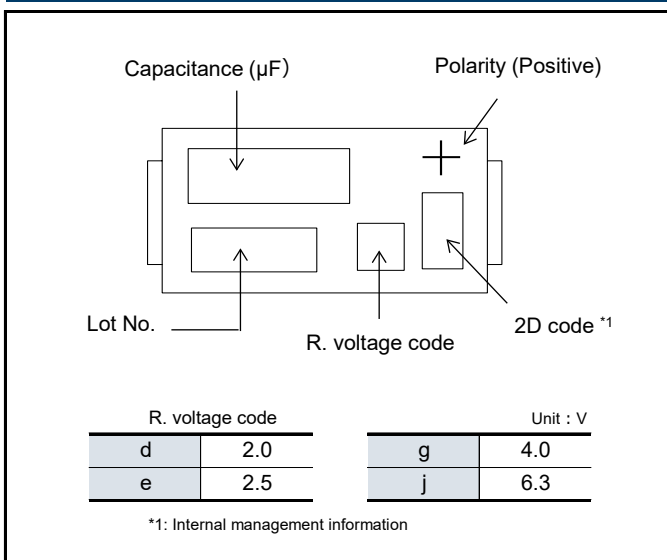

Dimensions (not to scale)

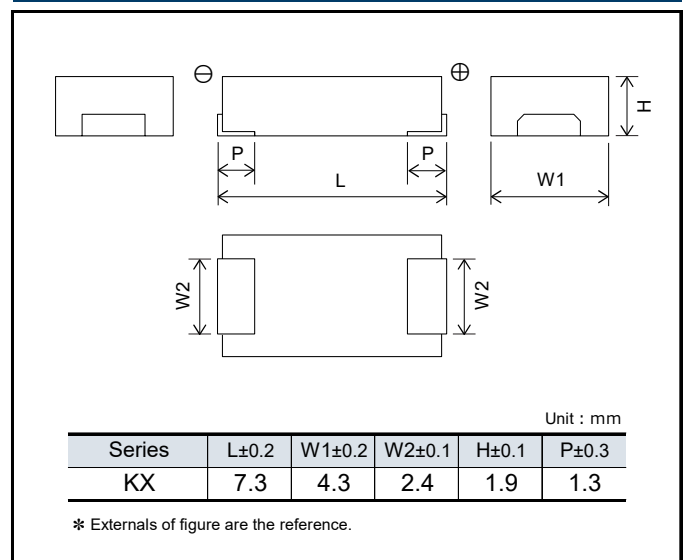

Explanation of part numbers

◆ Part number system e.g.: EEFKX0D331RE

EEF		KX		0D		331				RE	
Series	Product classification	Series	Code	Rated Voltage (V)	Code	Capacitance (μF)	Code	Capacitance (μF)	Code	ESR (mΩ)	Special code
KX	EEF	KX	KX	2.0	0D	120	121	330	331	3	RB
				2.5	0E	150	151	390	391	4.5	RC
				4.0	0G	180	181	470	471	9	RE
				6.3	0J	220	221			15	RF

Characteristics list

Series	Rated voltage [105 °C] (V)	Category voltage [125 °C] (V)	Capacitance (μF)	Case size (mm)			Specification		Part number	Min. Packaging Qty (pcs)
				L	W	H	Ripple current*1 (mA rms)	ESR*2 (mΩ max.)		
KX	2.0	1.6	330	7.3	4.3	1.9	6300	9	EEFKX0D331RE	3500
				7.3	4.3	1.9	6300	9	EEFKX0D471RE	3500
			470	7.3	4.3	1.9	8500	4.5	EEFKX0D471RC	3500
				7.3	4.3	1.9	10200	3	EEFKX0D471RB	3500
	2.5	2.0	220	7.3	4.3	1.9	6300	9	EEFKX0E221RE	3500
				7.3	4.3	1.9	6300	9	EEFKX0E331RE	3500
			390	7.3	4.3	1.9	6300	9	EEFKX0E391RE	3500
				7.3	4.3	1.9	8500	4.5	EEFKX0E391RC	3500
			470	7.3	4.3	1.9	10200	3	EEFKX0E391RB	3500
				7.3	4.3	1.9	6300	9	EEFKX0E471RE	3500
				7.3	4.3	1.9	8500	4.5	EEFKX0E471RC	3500
				7.3	4.3	1.9	10200	3	EEFKX0E471RB	3500
	4.0	3.2	150	7.3	4.3	1.9	5100	15	EEFKX0G151RF	3500
			180	7.3	4.3	1.9	5100	15	EEFKX0G181RF	3500
			220	7.3	4.3	1.9	5100	15	EEFKX0G221RF	3500
	6.3	5.0	120	7.3	4.3	1.9	5100	15	EEFKX0J121RF	3500
			150	7.3	4.3	1.9	5100	15	EEFKX0J151RF	3500

*1: Ripple current (100 kHz / +45 °C)

*2: ESR (100 kHz / +20 °C)

◆ Please refer to each page in this catalog for "Reflow conditions" and "Taping specifications".

Temperature coefficient of ripple current

Temperature		T ≤ 45 °C	45 °C < T ≤ 85 °C	85 °C < T ≤ 125 °C
2.0 V to 6.3 V	Coefficient	1.0	0.7	0.25

◆ Ripple current should be controlled so that surface temperature of capacitor does not exceed the category temperature.

Conductive Polymer Aluminum Electrolytic Capacitors

Surface Mount Type

TX series [High temperature long life product]

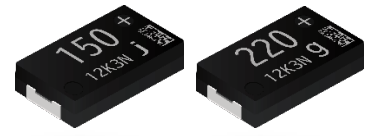

Notice: This product is not intended for use in automotive applications.

Features

- Endurance 135 °C 5500 h
- Damp heat 85°C 85% 1000 h
- Low ESR (3 ~ 15 mΩ max.)
- RoHS compliance, Halogen free

Specifications

Series	TX			
Category temp. range	-55 °C to +135 °C			
Rated voltage range	2.0 V to 6.3 V			
Category voltage range	1.6 V, 2.0 V, 3.2 V, 5.0 V			
Rated cap. range	120 μF to 470 μF			
Capacitance tolerance	±20 % (120 Hz / +20 °C)			
DC leakage current	I ≤ 0.1 CV (μA) 2 minutes			
Dissipation factor (tan δ)	≤ 0.1 (120 Hz / + 20 °C)			
Surge voltage (V)	Rated voltage × 1.25 (15 °C to 35 °C)			
Endurance	+135 °C 5500 h, category voltage applied			
	Capacitance change	Within ±20 % of the initial value		
	Dissipation factor (tan δ)	≤ 2 times of the initial limit		
	DC leakage current	≤ 3 times of the initial limit		
Damp heat (Steady state)	+85 °C, 85 % RH, 1000 h, No-applied voltage			
	Capacitance change of initial measured value	2.0 V, 2.5 V	4.0 V	6.3 V
		+70 %, -20 %	+60 %, -20 %	+50 %, -20 %
	Dissipation factor (tan δ)	≤ 2 times of the initial limit		
DC leakage current	≤ 5 times of the initial limit			

Marking

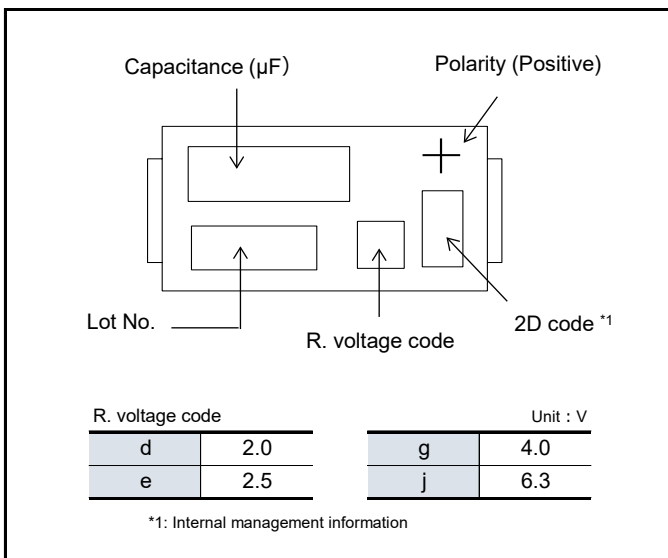

Dimensions (not to scale)

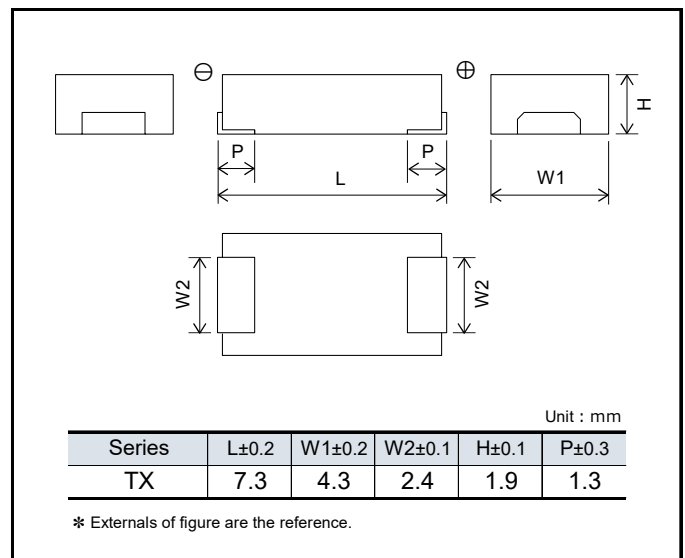

Explanation of part numbers

◇ Part number system e.g.: EEFTX0D331RE

EEF		TX		0D		331		RE			
Series	Product classification	Series	Code	Rated Voltage (V)	Code	Capacitance (μF)	Code	Capacitance (μF)	Code	ESR (mΩ)	Special code
TX	EEF	TX	TX	2.0	0D	120	121	330	331	3	RB
				2.5	0E	150	151	390	391	4.5	RC
				4.0	0G	180	181	470	471	9	RE
				6.3	0J	220	221			15	RF

Characteristics list

Series	Rated voltage [105 °C] (V)	Category voltage [135 °C] (V)	Capacitance (μF)	Case size (mm)			Specification		Part number	Min. Packaging Qty (pcs)
				L	W	H	Ripple current* ¹ (mA rms)	ESR* ² (mΩ max.)		
TX	2.0	1.6	330	7.3	4.3	1.9	6300	9	EEFTX0D331RE	3500
				7.3	4.3	1.9	6300	9	EEFTX0D471RE	3500
			470	7.3	4.3	1.9	8500	4.5	EEFTX0D471RC	3500
				7.3	4.3	1.9	10200	3	EEFTX0D471RB	3500
	2.5	2.0	220	7.3	4.3	1.9	6300	9	EEFTX0E221RE	3500
				7.3	4.3	1.9	6300	9	EEFTX0E331RE	3500
			390	7.3	4.3	1.9	6300	9	EEFTX0E391RE	3500
				7.3	4.3	1.9	8500	4.5	EEFTX0E391RC	3500
				7.3	4.3	1.9	10200	3	EEFTX0E391RB	3500
	4.0	3.2	150	7.3	4.3	1.9	5100	15	EEFTX0G151RF	3500
			180	7.3	4.3	1.9	5100	15	EEFTX0G181RF	3500
			220	7.3	4.3	1.9	5100	15	EEFTX0G221RF	3500
	6.3	5.0	120	7.3	4.3	1.9	5100	15	EEFTX0J121RF	3500
			150	7.3	4.3	1.9	5100	15	EEFTX0J151RF	3500

*1: Ripple current (100 kHz / +45 °C)

*2: ESR (100 kHz / +20 °C)

◆ Please refer to each page in this catalog for "Reflow conditions" and "Taping specifications".

Temperature coefficient of ripple current

Temperature		T ≤ 45 °C	45 °C < T ≤ 85 °C	85 °C < T ≤ 135 °C
2.0 V to 6.3 V	Coefficient	1.0	0.7	0.25

◆ Ripple current should be controlled so that surface temperature of capacitor does not exceed the category temperature.

Conductive Polymer Aluminum Electrolytic Capacitors

Surface Mount Type

JZ series [High temperature long life product]



Notice: This product is not intended for use in automotive applications.

Features

- Endurance 125 °C 3000 h
- Damp heat 85°C 85% 1000 h
- Low ESR (3 to 9 mΩ)
- RoHS compliance, Halogen free

Specifications

Series	JZ	
Category temp. range	-55 °C to +125 °C	
Rated voltage range	2.0 V	
Category voltage range	1.6 V	
Rated cap. range	560 μF	
Capacitance tolerance	±20 % (120 Hz / +20 °C)	
DC leakage current	I ≤ 0.1 CV (μA) 2 minutes	
Dissipation factor (tan δ)	≤ 0.1 (120 Hz / + 20 °C)	
Surge voltage (V)	Rated voltage × 1.25 (15 °C to 35 °C)	
Endurance	+125 °C 3000 h, category voltage applied	
	Capacitance change	Within ±20 % of the initial value
	Dissipation factor (tan δ)	≤ 2 times of the initial limit
	DC leakage current	≤ 3 times of the initial limit
Damp heat (Steady state)	+85 °C, 85 % RH, 1000 h, No-applied voltage	
	Capacitance change of initial measured value	2.0 V
		+70 %, -20 %
	Dissipation factor (tan δ)	≤ 2 times of the initial limit
DC leakage current	≤ 5 times of the initial limit	

Marking

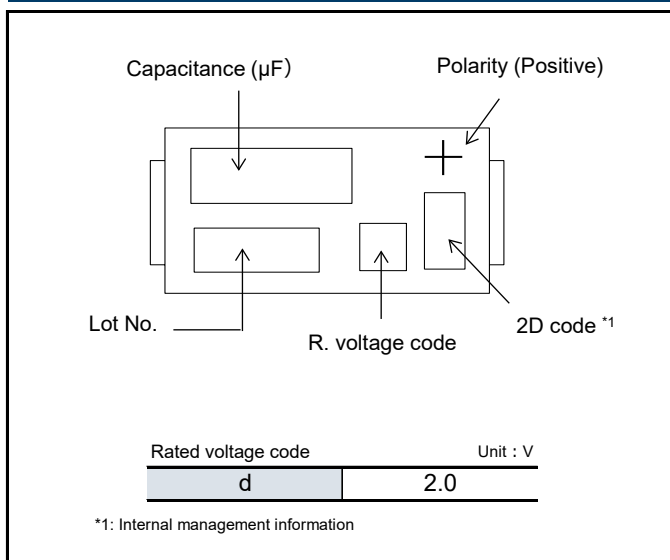

Dimensions (not to scale)

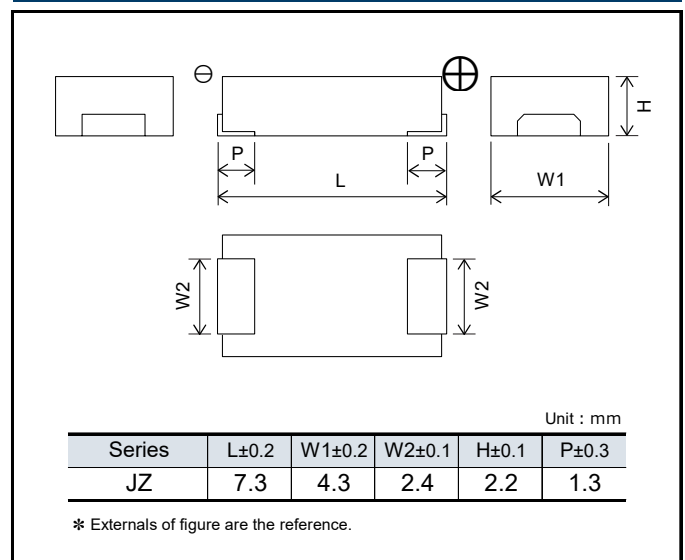

Explanation of part numbers

◇ Part number system e.g.: EEFJZ0D561RE

EEF		JZ		0D		561		RE	
Series	Product classification	Series	Code	Rated Voltage (V)	Code	Capacitance (μF)	Code	ESR (mΩ)	Special code
JZ	EEF	JZ	JZ	2.0	0D	560	561	3	RB
								4.5	RC
								9	RE

Characteristics list

Series	Rated voltage [105 °C] (V)	Category voltage [125 °C] (V)	Capacitance (μF)	Case size (mm)			Specification		Part number	Min. Packaging Q'ty (pcs)
				L	W	H	Ripple current*1 (mA rms)	ESR*2 (mΩ max.)		
JZ	2.0	1.6	560	7.3	4.3	2.2	6300	9	EEFJZ0D561RE	3000
				7.3	4.3	2.2	8500	4.5	EEFJZ0D561RC	3000
				7.3	4.3	2.2	10200	3	EEFJZ0D561RB	3000

*1: Ripple current (100 kHz / +45 °C)

*2: ESR (100 kHz / +20 °C)

◆ Please refer to each page in this catalog for "Reflow conditions" and "Taping specifications".

Temperature coefficient of ripple current

Temperature		T ≤ 45 °C	45 °C < T ≤ 85 °C	85 °C < T ≤ 125 °C
2.0 V	Coefficient	1.0	0.7	0.25

◆ Ripple current should be controlled so that surface temperature of capacitor does not exceed the category temperature.

**Conductive Polymer Aluminum
Electrolytic Capacitors**
Surface Mount Type



KZ series [High temperature long life product]

Notice: This product is not intended for use in automotive applications.

Features

- Endurance 125 °C 5500 h
- Damp heat 85°C 85% 1000 h
- Low ESR (3 to 9 mΩ)
- RoHS compliance, Halogen free

Specifications

Series	KZ	
Category temp. range	-55 °C to +125 °C	
Rated voltage range	2.0 V	
Category voltage range	1.6 V	
Rated cap. range	560 μF	
Capacitance tolerance	±20 % (120 Hz / +20 °C)	
DC leakage current	I ≤ 0.1 CV (μA) 2 minutes	
Dissipation factor (tan δ)	≤ 0.1 (120 Hz / + 20 °C)	
Surge voltage (V)	Rated voltage × 1.25 (15 °C to 35 °C)	
Endurance	+125 °C 5500 h, category voltage applied	
	Capacitance change	Within ±20 % of the initial value
	Dissipation factor (tan δ)	≤ 2 times of the initial limit
	DC leakage current	≤ 3 times of the initial limit
Damp heat (Steady state)	+85 °C, 85 % RH, 1000 h, No-applied voltage	
	Capacitance change of initial measured value	2.0 V +70 %, -20 %
	Dissipation factor (tan δ)	≤ 2 times of the initial limit
	DC leakage current	≤ 5 times of the initial limit

Marking

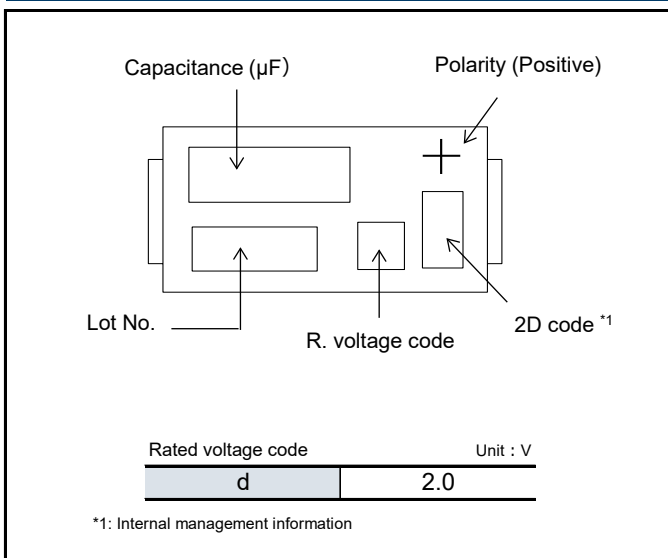

Dimensions (not to scale)

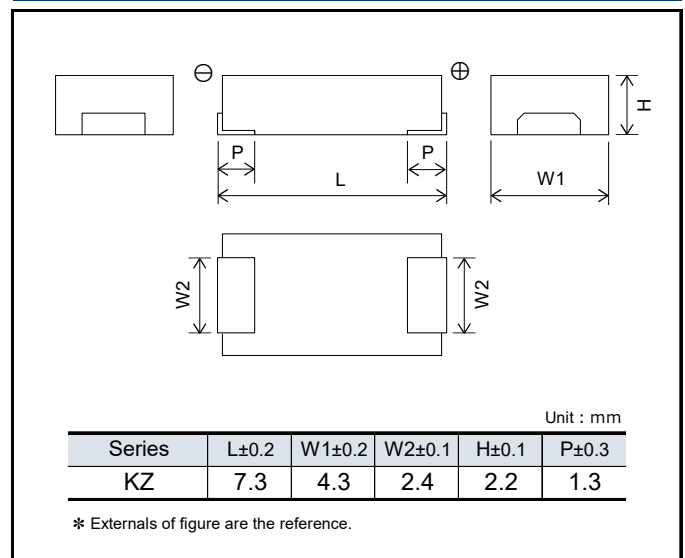

Explanation of part numbers

◇ Part number system e.g.: EEFKZ0D561RE

EEF		KZ		0D		561		RE	
Series	Product classification	Series	Code	Rated Voltage (V)	Code	Capacitance (μF)	Code	ESR (mΩ)	Special code
KZ	EEF	KZ	KZ	2.0	0D	560	561	3	RB
								4.5	RC
								9	RE

Characteristics list

Series	Rated voltage [105 °C] (V)	Category voltage [125 °C] (V)	Capacitance (μF)	Case size (mm)			Specification		Part number	Min. Packaging Q'ty (pcs)
				L	W	H	Ripple current* ¹ (mA rms)	ESR* ² (mΩ max.)		
KZ	2.0	1.6	560	7.3	4.3	2.2	6300	9	EEFKZ0D561RE	3000
				7.3	4.3	2.2	8500	4.5	EEFKZ0D561RC	3000
				7.3	4.3	2.2	10200	3	EEFKZ0D561RB	3000

*1: Ripple current (100 kHz / +45 °C)

*2: ESR (100 kHz / +20 °C)

◆ Please refer to each page in this catalog for "Reflow conditions" and "Taping specifications".

Temperature coefficient of ripple current

Temperature		T ≤ 45 °C	45 °C < T ≤ 85 °C	85 °C < T ≤ 125 °C
2.0 V	Coefficient	1.0	0.7	0.25

◆ Ripple current should be controlled so that surface temperature of capacitor does not exceed the category temperature.

**Conductive Polymer Aluminum
Electrolytic Capacitors**
Surface Mount Type

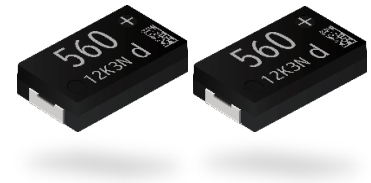

TZ series [High temperature long life product]

Notice: This product is not intended for use in automotive applications.

Features

- Endurance 135 °C 5500 h
- Damp heat 85°C 85% 1000 h
- Low ESR (3 to 9 mΩ)
- RoHS compliance, Halogen free

Specifications

Series	TZ	
Category temp. range	-55 °C to +135 °C	
Rated voltage range	2.0 V	
Category voltage range	1.6 V	
Rated cap. range	560 μF	
Capacitance tolerance	±20 % (120 Hz / +20 °C)	
DC leakage current	I ≤ 0.1 CV (μA) 2 minutes	
Dissipation factor (tan δ)	≤ 0.1 (120 Hz / + 20 °C)	
Surge voltage (V)	Rated voltage × 1.25 (15 °C to 35 °C)	
Endurance	+135 °C 5500 h, category voltage applied	
	Capacitance change	Within ±20 % of the initial value
	Dissipation factor (tan δ)	≤ 2 times of the initial limit
	DC leakage current	≤ 3 times of the initial limit
Damp heat (Steady state)	+85 °C, 85 % RH, 1000 h, No-applied voltage	
	Capacitance change of initial measured value	2.0 V
		+70 %, -20 %
	Dissipation factor (tan δ)	≤ 2 times of the initial limit
DC leakage current	≤ 5 times of the initial limit	

Marking

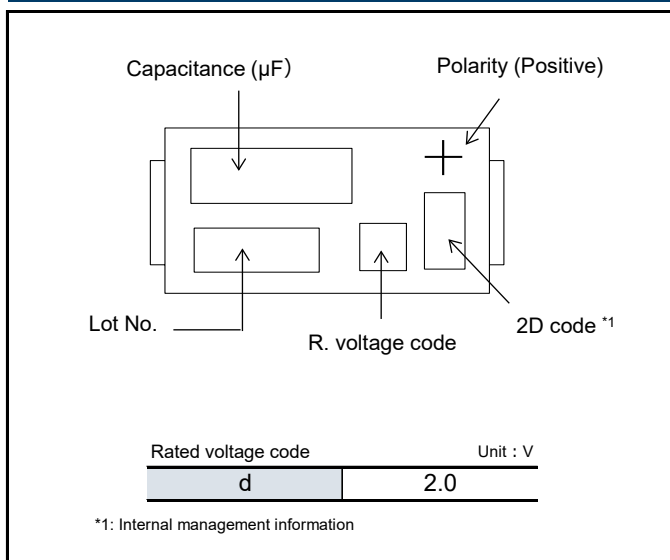

Dimensions (not to scale)

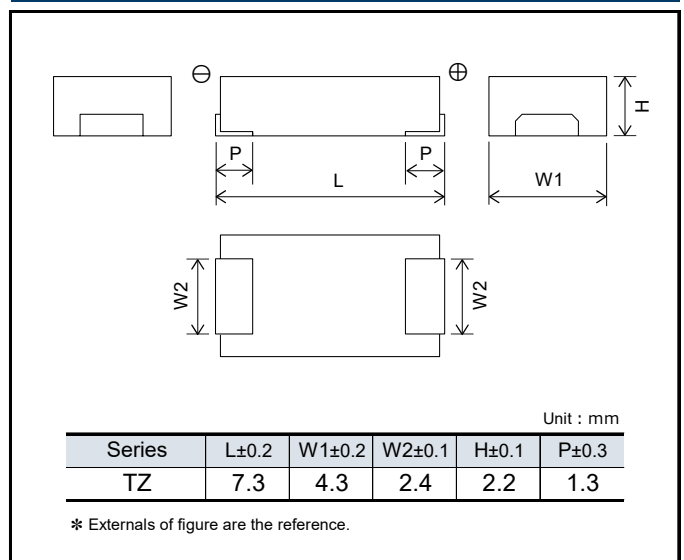

Explanation of part numbers

◇ Part number system e.g.: EEFTZ0D561RE

EEF		TZ		0D		561		RE	
Series	Product classification	Series	Code	Rated Voltage (V)	Code	Capacitance (μF)	Code	ESR (mΩ)	Special code
TZ	EEF	TZ	TZ	2.0	0D	560	561	3	RB
								4.5	RC
								9	RE

Characteristics list

Series	Rated voltage [105 °C] (V)	Category voltage [135 °C] (V)	Capacitance (μF)	Case size (mm)			Specification		Part number	Min. Packaging Q'ty (pcs)
				L	W	H	Ripple current*1 (mA rms)	ESR*2 (mΩ max.)		
TZ	2.0	1.6	560	7.3	4.3	2.2	6300	9	EEFTZ0D561RE	3000
				7.3	4.3	2.2	8500	4.5	EEFTZ0D561RC	3000
				7.3	4.3	2.2	10200	3	EEFTZ0D561RB	3000

*1: Ripple current (100 kHz / +45 °C)

*2: ESR (100 kHz / +20 °C)

◆ Please refer to each page in this catalog for "Reflow conditions" and "Taping specifications".

Temperature coefficient of ripple current

Temperature		T ≤ 45 °C	45 °C < T ≤ 85 °C	85 °C < T ≤ 135 °C
2.0 V	Coefficient	1.0	0.7	0.25

◆ Ripple current should be controlled so that surface temperature of capacitor does not exceed the category temperature.

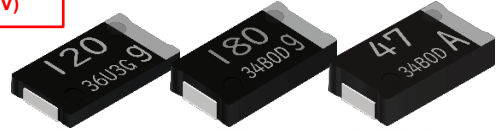

Conductive Polymer Aluminum Electrolytic Capacitors

Surface Mount Type

CS/CT/CX series

When SP-Cap is designed to be used under constant high load application such as represented in but not limited to the following products such as AI servers, switches, routers, and base stations, we strongly recommend using the long-life series (JX/KX/TX series) and avoid choosing standard series (CS/CT/CX series).

Notice: This product is not intended for use in automotive applications.

Features

- High voltage (35 V max.)
- Low profile (Height 1.0 mm max.)
- High ripple current (5600 mA rms max.)
- RoHS compliance, Halogen free

Specifications

Series	CS	CT	CX	
Category temp. range	-55 °C to +105 °C			
Rated voltage range	4.0 V to 35 V		2.0 V to 35 V	
Rated cap. range	10 μF to 120 μF	15 μF to 180 μF	15 μF to 560 μF	
Capacitance tolerance	±20 % (120 Hz / +20 °C)			
DC leakage current	I ≤ 0.1 CV(μA) [2.0 V to 6.3 V, 2 min], I ≤ 0.3 CV(μA) [10 V to 35 V, 2 min]			
Dissipation factor (tan δ)	≤ 0.06 (120 Hz / + 20 °C)			
Surge voltage (V)	Rated voltage × 1.25 [2.0 V to 16 V], × 1.15 [20 V to 35 V] (15 °C to 35 °C)			
Endurance	+105 °C 2000 h, rated voltage applied			
	Capacitance change	Within ±20 % of the initial value		
	Dissipation factor (tan δ)	≤ 2 times of the initial limit		
	DC leakage current	≤ 3 times of the initial limit : 2.0 V to 6.3 V Within the initial limit : 10 V to 35 V		
Damp heat (Steady state)	+60 °C, 90 % RH, 500 h, No-applied voltage			
	Capacitance change of initial measurd value	2.0 V to 2.5 V +70 %, -20 %	4.0 V, 10 V to 35 V +60 %, -20 %	6.3 V +50 %, -20 %
	Dissipation factor (tan δ)	≤ 2 times of the initial limit		
	DC leakage current	Within the initial limit : 2.0 V to 6.3 V ≤ 3 times of the initial limit : 10 V to 35 V		

Marking

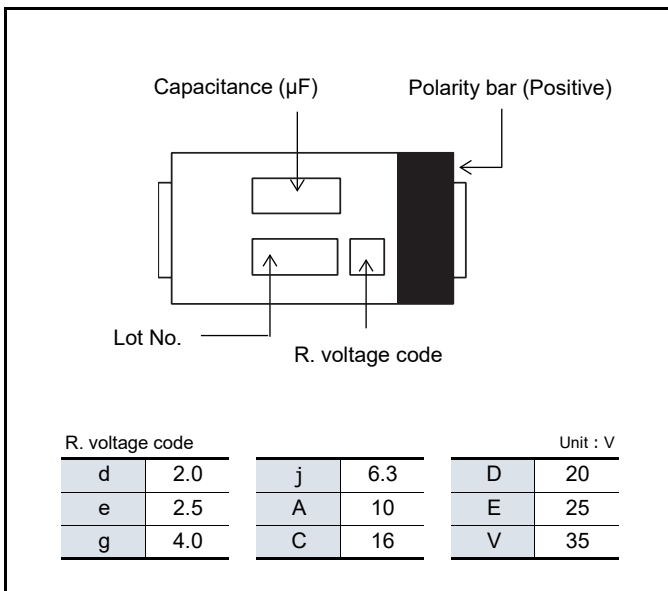

Dimensions (not to scale)

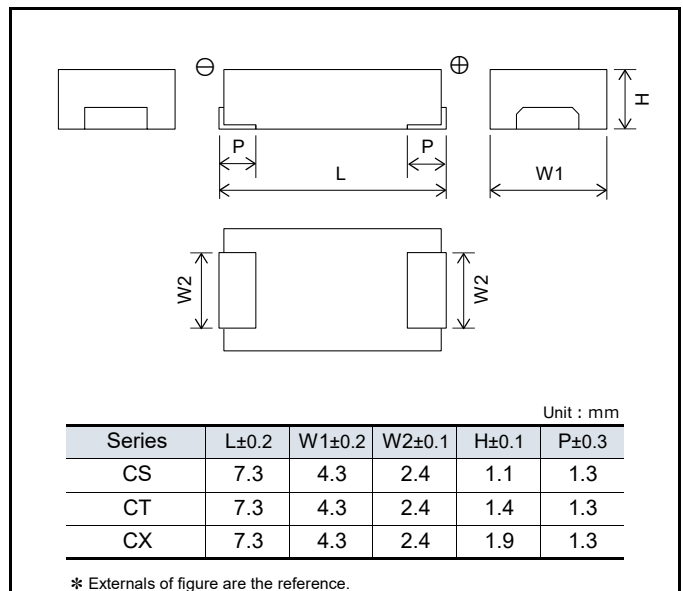

Explanation of part numbers

◇ Part number system e.g.: EEFC0G121R

EEF		CS		0G		121		R			
Series	Product classification	Series	Code	Rated Voltage (V)	Code	Capacitance (μF)	Code	Capacitance (μF)	Code	ESR (mΩ)	Special code
CS	EEF	CS	CS	2.0	0D	10	100	150	151	15 (2.0 to 6.3 V) 40 (10 to 35 V)	R
CT		CT	2.5	0E	15	150	180	181			
CX		CX	4.0	0G	22	220	220	220	221		
				6.3	0J	33	330	270	271	12	XR
				10	1A	47	470	330	331		
				16	1C	56	560	390	391		
				20	1D	68	680	470	471		
				25	1E	100	101	560	561		
				35	1V	120	121				

Characteristics list

■ 2.0 V to 6.3 V

Series	Rated voltage (V)	Capacitance (μF)	Case size (mm)			Specification		Part number	Min. Packaging Qty (pcs)
			L	W	H	Ripple current ^{*1} (mA rms)	ESR ^{*2} (mΩ max.)		
CS	4.0	120	7.3	4.3	1.1	5100	15	EEFC0G121R	3500
	6.3	68	7.3	4.3	1.1	5100	15	EEFC0J680R	3500
CT	4.0	180	7.3	4.3	1.4	5100	15	EEFC0G181R	3500
	6.3	100	7.3	4.3	1.4	5100	15	EEFC0J101R	3500
CX	2.0	220	7.3	4.3	1.9	5100	15	EEFC0D221R	3500
		270	7.3	4.3	1.9	5600	12	EEFC0D271XR	3500
		330	7.3	4.3	1.9	5100	15	EEFC0D331R	3500
			7.3	4.3	1.9	5600	12	EEFC0D331XR	3500
		390	7.3	4.3	1.9	5100	15	EEFC0D391R	3500
		470	7.3	4.3	1.9	5100	15	EEFC0D471R	3500
	560	7.3	4.3	1.9	5100	15	EEFC0D561R	3500	
	2.5	220	7.3	4.3	1.9	5100	15	EEFC0E221R	3500
		330	7.3	4.3	1.9	5100	15	EEFC0E331R	3500
		390	7.3	4.3	1.9	5100	15	EEFC0E391R	3500
		470	7.3	4.3	1.9	5100	15	EEFC0E471R	3500
	4.0	150	7.3	4.3	1.9	5100	15	EEFC0G151R	3500
			7.3	4.3	1.9	5100	15	EEFC0G181R	3500
		180	7.3	4.3	1.9	5600	12	EEFC0G181XR	3500
			7.3	4.3	1.9	5100	15	EEFC0G221R	3500
		220	7.3	4.3	1.9	5600	12	EEFC0G221XR	3500
			7.3	4.3	1.9	5100	15	EEFC0G271R	3500
	330	7.3	4.3	1.9	5100	15	EEFC0G331R	3500	
	6.3	100	7.3	4.3	1.9	5100	15	EEFC0J101R	3500
			7.3	4.3	1.9	5100	15	EEFC0J121R	3500
150		7.3	4.3	1.9	5100	15	EEFC0J151R	3500	
		7.3	4.3	1.9	5600	12	EEFC0J151XR	3500	
180		7.3	4.3	1.9	5100	15	EEFC0J181R	3500	
		7.3	4.3	1.9	5100	15	EEFC0J221R	3500	

*1: Ripple current (100 kHz / +45 °C)

*2: ESR (100 kHz / +20 °C)

◆ Please refer to each page in this catalog for "Reflow conditions" and "Taping specifications".

Temperature coefficient of ripple current

Temperature		T ≤ 45 °C	45 °C < T ≤ 85 °C	85 °C < T ≤ 105 °C
2.0 V to 6.3 V	Coefficient	1.0	0.7	0.25

◆ Ripple current should be controlled so that surface temperature of capacitor does not exceed the category temperature.

Characteristics list

■ 10 V to 35 V

Not Recommended for New Design

For replacement

Series	Rated voltage (V)	Capacitance (μF)	Case size (mm)			Specification		Part number	Min. Packaging Qty (pcs)
			L	W	H	Ripple current ^{*1} (mA rms)	ESR ^{*2} (mΩ max.)		
CS	10	47	7.3	4.3	1.1	3200	40	EEFCS1A470R	3500
	16	15	7.3	4.3	1.1	3200	40	EEFCS1C150R	3500
		22	7.3	4.3	1.1	3200	40	EEFCS1C220R	3500
		33	7.3	4.3	1.1	3200	40	EEFCS1C330R	3500
	20	10	7.3	4.3	1.1	3200	40	EEFCS1D100R	3500
		15	7.3	4.3	1.1	3200	40	EEFCS1D150R	3500
		22	7.3	4.3	1.1	3200	40	EEFCS1D220R	3500
	25	10	7.3	4.3	1.1	3200	40	EEFCS1E100R	3500
		15	7.3	4.3	1.1	3200	40	EEFCS1E150R	3500
	35	10	7.3	4.3	1.1	3200	40	EEFCS1V100R	3500
CT	10	68	7.3	4.3	1.4	3200	40	EEFCT1A680R	3500
	16	47	7.3	4.3	1.4	3200	40	EEFCT1C470R	3500
		33	7.3	4.3	1.4	3200	40	EEFCT1D330R	3500
	20	47	7.3	4.3	1.4	3200	40	EEFCT1D470R	3500
		22	7.3	4.3	1.4	3200	40	EEFCT1E220R	3500
	35	15	7.3	4.3	1.4	3200	40	EEFCT1V150R	3500
CX	10	47	7.3	4.3	1.9	3200	40	EEFCX1A470R	3500
		68	7.3	4.3	1.9	3200	40	EEFCX1A680R	3500
		100	7.3	4.3	1.9	3200	40	EEFCX1A101R	3500
	16	15	7.3	4.3	1.9	3200	40	EEFCX1C150R	3500
		22	7.3	4.3	1.9	3200	40	EEFCX1C220R	3500
		33	7.3	4.3	1.9	3200	40	EEFCX1C330R	3500
		47	7.3	4.3	1.9	3200	40	EEFCX1C470R	3500
		68	7.3	4.3	1.9	3200	40	EEFCX1C680R	3500
		22	7.3	4.3	1.9	3200	40	EEFCX1D220R	3500
	20	33	7.3	4.3	1.9	3200	40	EEFCX1D330R	3500
		47	7.3	4.3	1.9	3200	40	EEFCX1D470R	3500
		56	7.3	4.3	1.9	3200	40	EEFCX1D560R	3500
		15	7.3	4.3	1.9	3200	40	EEFCX1E150R	3500
	25	22	7.3	4.3	1.9	3200	40	EEFCX1E220R	3500
		33	7.3	4.3	1.9	3200	40	EEFCX1E330R	3500
		15	7.3	4.3	1.9	3200	40	EEFCX1V150R	3500
	35	22	7.3	4.3	1.9	3200	40	EEFCX1V220R	3500

*1: Ripple current (100 kHz / +45 °C)

*2: ESR (100 kHz / +20 °C)

◆ Please refer to each page in this catalog for "Reflow conditions" and "Taping specifications".

Temperature coefficient of ripple current

Temperature		T ≤ 45 °C	45 °C < T ≤ 85 °C	85 °C < T ≤ 105 °C
10 V to 35 V	Coefficient	1.0	0.8	0.5

◆ Ripple current should be controlled so that surface temperature of capacitor does not exceed the category temperature.

Conductive Polymer Aluminum Electrolytic Capacitors

Surface Mount Type

SX series [Low ESR products]

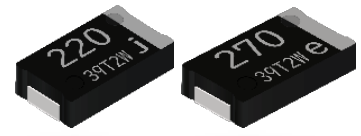

When SP-Cap is designed to be used under constant high load application such as represented in but not limited to the following products such as AI servers, switches, routers, and base stations, we strongly recommend using the long-life series (JX/KX/TX series) and avoid choosing standard series (SX series).

Notice: This product is not intended for use in automotive applications.

Features

- Large capacitance (560 μF max.)
- Low ESR (4.5 mΩ to 9 mΩ max.)
- High ripple current (8500 mA rms max.)
- RoHS compliance, Halogen free

Specifications

Series	SX			
Category temp. range	-55 °C to +105 °C			
Rated voltage range	2.0 V to 6.3 V			
Rated cap. range	82 μF to 560 μF			
Capacitance tolerance	±20 % (120 Hz / +20 °C)			
DC leakage current	I ≤ 0.1 CV (μA) 2 minutes			
Dissipation factor (tan δ)	≤ 0.06 (120 Hz / + 20 °C)			
Surge voltage (V)	Rated voltage × 1.25 (15 °C to 35 °C)			
Endurance	+105 °C 2000 h, rated voltage applied			
	Capacitance change	Within ±20 % of the initial value		
	Dissipation factor (tan δ)	≤ 2 times of the initial limit		
	DC leakage current	≤ 3 times of the initial limit		
Damp heat (Steady state)	+60 °C, 90 % RH, 500 h, No-applied voltage			
	Capacitance change of initial measurd value	2.0 V to 2.5 V	4.0 V	6.3 V
		+70 %, -20 %	+60 %, -20 %	+50 %, -20 %
	Dissipation factor (tan δ)	≤ 2 times of the initial limit		
DC leakage current	Within the initial limit			

Marking

Capacitance (μF) Polarity bar (Positive)

Lot No. R. voltage code

R. voltage code		Unit : V	
d	2.0	g	4.0
e	2.5	j	6.3

Dimensions (not to scale)

Unit : mm					
Series	L±0.2	W1±0.2	W2±0.1	H±0.1	P±0.3
SX	7.3	4.3	2.4	1.9	1.3

* Externals of figure are the reference.

Explanation of part numbers

◆ **Part number system** e.g.: EEFSX0D271XE

EEF		SX		OD		271				XE	
Series	Product classification	Series	Code	Rated Voltage (V)	Code	Capacitance (μF)	Code	Capacitance (μF)	Code	ESR (mΩ)	Special code
SX	EEF	SX	SX	2.0	OD	82	820	270	271	4.5	E4
				2.5	OE	100	101	330	331	6	XE
				4.0	OG	120	121	390	391	7	E7
				6.3	OJ	150	151	470	471	9	ER
						180	181	560	561		
						220	221				

Characteristics list

Series	Rated voltage (V)	Capacitance (μF)	Case size (mm)			Specification		Part number	Min. Packaging Qty (pcs)		
			L	W	H	Ripple current* ¹ (mA rms)	ESR* ² (mΩ max.)				
SX	2.0	180	7.3	4.3	1.9	6300	9	EEFSX0D181ER	3500		
		220	7.3	4.3	1.9	6300	9	EEFSX0D221ER	3500		
		270	7.3	4.3	1.9	6300	9	EEFSX0D271ER	3500		
			7.3	4.3	1.9	7500	6	EEFSX0D271XE	3500		
		330	7.3	4.3	1.9	8500	4.5	EEFSX0D271E4	3500		
			7.3	4.3	1.9	6300	9	EEFSX0D331ER	3500		
			7.3	4.3	1.9	7500	6	EEFSX0D331XE	3500		
		390	7.3	4.3	1.9	8500	4.5	EEFSX0D331E4	3500		
			7.3	4.3	1.9	6300	9	EEFSX0D391ER	3500		
			7.3	4.3	1.9	7500	6	EEFSX0D391XE	3500		
		470	7.3	4.3	1.9	8500	4.5	EEFSX0D391E4	3500		
			7.3	4.3	1.9	6300	9	EEFSX0D471ER	3500		
			7.3	4.3	1.9	7500	6	EEFSX0D471XE	3500		
				7.3	4.3	1.9	8500	4.5	EEFSX0D471E4	3500	
				560	7.3	4.3	1.9	8500	4.5	EEFSX0D561E4	3500
		2.5	150	7.3	4.3	1.9	6300	9	EEFSX0E151ER	3500	
			180	7.3	4.3	1.9	6300	9	EEFSX0E181ER	3500	
			220	7.3	4.3	1.9	6300	9	EEFSX0E221ER	3500	
	7.3			4.3	1.9	7000	7	EEFSX0E221E7	3500		
	270		7.3	4.3	1.9	7000	7	EEFSX0E271E7	3500		
			7.3	4.3	1.9	6300	9	EEFSX0E331ER	3500		
			7.3	4.3	1.9	7500	6	EEFSX0E331XE	3500		
	330		7.3	4.3	1.9	8500	4.5	EEFSX0E331E4	3500		
			7.3	4.3	1.9	6300	9	EEFSX0E391ER	3500		
			7.3	4.3	1.9	7500	6	EEFSX0E391XE	3500		
	390		7.3	4.3	1.9	8500	4.5	EEFSX0E391E4	3500		
			7.3	4.3	1.9	6300	9	EEFSX0E471ER	3500		
			7.3	4.3	1.9	7500	6	EEFSX0E471XE	3500		
				7.3	4.3	1.9	8500	4.5	EEFSX0E471E4	3500	
	4.0		82	7.3	4.3	1.9	6300	9	EEFSX0G820ER	3500	
			100	7.3	4.3	1.9	6300	9	EEFSX0G101ER	3500	
				7.3	4.3	1.9	6300	9	EEFSX0G151ER	3500	
			150	7.3	4.3	1.9	7000	7	EEFSX0G151E7	3500	
		7.3		4.3	1.9	6300	9	EEFSX0G181ER	3500		
		220	7.3	4.3	1.9	6300	9	EEFSX0G221ER	3500		
		270	7.3	4.3	1.9	6300	9	EEFSX0G271ER	3500		
7.3			4.3	1.9	6300	9	EEFSX0G331ER	3500			
		7.3	4.3	1.9	7500	6	EEFSX0G331XE	3500			
6.3	120	7.3	4.3	1.9	7000	7	EEFSX0J121E7	3500			
	150	7.3	4.3	1.9	6300	9	EEFSX0J151ER	3500			
	180	7.3	4.3	1.9	6300	9	EEFSX0J181ER	3500			
	220	7.3	4.3	1.9	6300	9	EEFSX0J221ER	3500			

*1: Ripple current (100 kHz / +45 °C) *2: ESR (100 kHz / +20 °C)

◆ Please refer to each page in this catalog for "Reflow conditions" and "Taping specifications".

Temperature coefficient of ripple current

Temperature		T ≤ 45 °C	45 °C < T ≤ 85 °C	85 °C < T ≤ 105 °C
2.0 V to 6.3 V	Coefficient	1.0	0.7	0.25

◆ Ripple current should be controlled so that surface temperature of capacitor does not exceed the category temperature.

**Conductive Polymer Aluminum
Electrolytic Capacitors**

Surface Mount Type

GX/GX-L series [Super low ESR products]

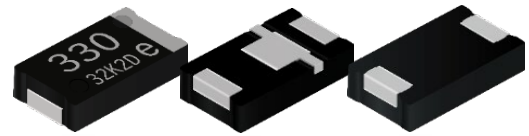

When SP-Cap is designed to be used under constant high load application such as represented in but not limited to the following products such as AI servers, switches, routers, and base stations, we strongly recommend using the long-life series (JX/KX/TX series) and avoid choosing standard series (GX/GX-L series).

Notice: This product is not intended for use in automotive applications.

Features

- Large capacitance (560 μF max.)
- Super Low ESR (3 $\text{m}\Omega$ max.)
- Low ESL (3-terminals : 50 % less than 2-terminals) [Suffix : L]
- High ripple current (10200 mA rms max.)
- RoHS compliance, Halogen free

Specifications

Series	GX	
Category temp. range	-55 °C to +105 °C	
Rated voltage range	2.0 V to 2.5 V	
Rated cap. range	330 μF to 560 μF	
Capacitance tolerance	$\pm 20\%$ (120 Hz / +20 °C)	
DC leakage current	$I \leq 0.1 \text{ CV}$ (μA) 2 minutes	
Dissipation factor (tan δ)	≤ 0.06 (120 Hz / +20 °C)	
Surge voltage (V)	Rated voltage $\times 1.25$ (15 °C to 35 °C)	
Endurance	+105 °C 2000 h, rated voltage applied	
	Capacitance change	Within $\pm 20\%$ of the initial value
	Dissipation factor (tan δ)	≤ 2 times of the initial limit
	DC leakage current	≤ 3 times of the initial limit
Damp heat (Steady state)	+60 °C, 90 % RH, 500 h, No-applied voltage	
	Capacitance change of initial measured value	2.0 V to 2.5 V +70 %, -20 %
	Dissipation factor (tan δ)	≤ 2 times of the initial limit
	DC leakage current	Within the initial limit

Marking

Capacitance (μF) Polarity bar (Positive)

Lot No. R. voltage code

R. voltage code	Unit : V
d	2.0
e	2.5

Dimensions (not to scale)

2 terminals

3 terminals

	Unit : mm				
Series	L ± 0.2	W1 ± 0.2	W2 ± 0.1	H ± 0.1	P ± 0.3
GX	7.3	4.3	2.4	1.9	1.3

	Unit : mm							
Series	L ± 0.2	W1 ± 0.2	W2 ± 0.1	H ± 0.1	P1 ± 0.3	P2 ± 0.1	P3 ± 0.2	P4 ± 0.2
GX-L	7.3	4.3	2.4	1.9	1.3	1.1	0.7	1.4

* Externals of figure are the reference.

Design and specifications are each subject to change without notice. Ask factory for the current technical specifications before purchase and/or use. Should a safety concern arise regarding this product, please be sure to contact us immediately. If delivery specifications suitable for the intended use was not exchanged at the time of product purchase, we will not bear any responsibility.

Explanation of part numbers

◇ Part number system e.g.: EEFGX0D331R

EEF		GX		0D		331		R	
Series	Product classification	Series	Code	Rated Voltage (V)	Code	Capacitance (μF)	Code	ESR (mΩ)	Special code
GX	EEF	GX	GX	2.0	0D	330	331	3	L, R
				2.5	0E	470	471		
						560	561		

Characteristics list

Series	Rated voltage (V)	Capacitance (μF)	Case size (mm)			Specification		The number of terminals		Part number	Min. Packaging Qty (pcs)	
			L	W	H	Ripple current* ¹ (mA rms)	ESR* ² (mΩ max.)	2	3			
GX	2.0	330	7.3	4.3	1.9	10200	3	○		EEFGX0D331R	3500	
			7.3	4.3	1.9	10200	3	○		EEFGX0D471R	3500	
		470	7.3	4.3	1.9	10200	3		○	EEFGX0D471L	3500	
			560	7.3	4.3	1.9	10200	3	○		EEFGX0D561R	3500
				7.3	4.3	1.9	10200	3		○	EEFGX0D561L	3500
	2.5	330	7.3	4.3	1.9	10200	3	○		EEFGX0E331R	3500	
			470	7.3	4.3	1.9	10200	3	○		EEFGX0E471R	3500
		7.3		4.3	1.9	10200	3		○	EEFGX0E471L	3500	

*1: Ripple current (100 kHz / +45 °C)

*2: ESR (100 kHz / +20 °C)

◆ Please refer to each page in this catalog for "Reflow conditions" and "Taping specifications".

Temperature coefficient of ripple current

Temperature		T ≤ 45 °C	45 °C < T ≤ 85 °C	85 °C < T ≤ 105 °C
2.0 V to 2.5 V	Coefficient	1.0	0.7	0.25

◆ Ripple current should be controlled so that surface temperature of capacitor does not exceed the category temperature.

Conductive Polymer Aluminum Electrolytic Capacitors

Surface Mount Type

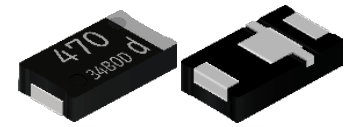

LX series [Low ESR / Low ESL products]

When SP-Cap is designed to be used under constant high load application such as represented in but not limited to the following products such as AI servers, switches, routers, and base stations, we strongly recommend using the long-life series (JX/KX/TX series) and avoid choosing standard series (LX series).

Notice: This product is not intended for use in automotive applications.

Features

- Large capacitance (560 μF max.)
- Low ESR (4.5 mΩ, 6 mΩ max.)
- Low ESL (3-terminals : 50 % less than 2-terminals)
- High ripple current (8500 mA rms max.)
- RoHS compliance, Halogen free

Specifications

Series	LX	
Category temp. range	-55 °C to +105 °C	
Rated voltage range	2.0 V to 2.5 V	
Rated cap. range	330 μF to 560 μF	
Capacitance tolerance	±20 % (120 Hz / +20 °C)	
DC leakage current	I ≤ 0.1 CV (μA) 2 minutes	
Dissipation factor (tan δ)	≤ 0.06 (120 Hz / +20 °C)	
Surge voltage (V)	Rated voltage × 1.25 (15 °C to 35 °C)	
Endurance	+105 °C 2000 h, rated voltage applied	
	Capacitance change	Within ±20 % of the initial value
	Dissipation factor (tan δ)	≤ 2 times of the initial limit
	DC leakage current	≤ 3 times of the initial limit
Damp heat (Steady state)	+60 °C, 90 % RH, 500 h, No-applied voltage	
	Capacitance change of initial measured value	2.0 V to 2.5 V +70 %, -20 %
	Dissipation factor (tan δ)	≤ 2 times of the initial limit
	DC leakage current	Within the initial limit

Marking Dimensions (not to scale)

Capacitance (μF) Polarity bar (Positive)

Lot No. R. voltage code

R. voltage code	Unit : V
d	2.0
e	2.5

3 terminals

Series	L±0.2	W1±0.2	W2±0.1	H±0.1	P1±0.3	P2±0.1	P3±0.2	P4±0.2
LX	7.3	4.3	2.4	1.9	1.3	1.1	0.7	1.4

Unit : mm

* Externals of figure are the reference.

Explanation of part numbers

◇ Part number system e.g.: EEFLX0D331R

EEF		LX		0D		331		R	
Series	Product classification	Series	Code	Rated Voltage (V)	Code	Capacitance (μF)	Code	ESR (mΩ)	Special code
LX	EEF	LX	LX	2.0	0D	330	331	4.5	R4
				2.5	0E	470	471	6	R
						560	561		

Characteristics list

Series	Rated voltage (V)	Capacitance (μF)	Case size (mm)			Specification		Part number	Min. Packaging Q'ty (pcs)
			L	W	H	Ripple current* ¹ (mA rms)	ESR* ² (mΩ max.)		
LX	2.0	330	7.3	4.3	1.9	7500	6	EEFLX0D331R	3500
			7.3	4.3	1.9	8500	4.5	EEFLX0D331R4	3500
		470	7.3	4.3	1.9	7500	6	EEFLX0D471R	3500
			7.3	4.3	1.9	8500	4.5	EEFLX0D471R4	3500
		560	7.3	4.3	1.9	7500	6	EEFLX0D561R	3500
			7.3	4.3	1.9	8500	4.5	EEFLX0D561R4	3500
	2.5	330	7.3	4.3	1.9	7500	6	EEFLX0E331R	3500
			7.3	4.3	1.9	8500	4.5	EEFLX0E331R4	3500
		470	7.3	4.3	1.9	7500	6	EEFLX0E471R	3500
			7.3	4.3	1.9	8500	4.5	EEFLX0E471R4	3500

*1: Ripple current (100 kHz / +45 °C)

*2: ESR (100 kHz / +20 °C)

◆ Please refer to each page in this catalog for "Reflow conditions" and "Taping specifications".

Temperature coefficient of ripple current

Temperature		T ≤ 45 °C	45 °C < T ≤ 85 °C	85 °C < T ≤ 105 °C
2.0 V to 2.5 V	Coefficient	1.0	0.7	0.25

◆ Ripple current should be controlled so that surface temperature of capacitor does not exceed the category temperature.

**Conductive Polymer Aluminum
Electrolytic Capacitors**
Surface Mount Type
SR/LR/SS/LS/ST/LT series



When SP-Cap is designed to be used under constant high load application such as represented in but not limited to the following products such as AI servers, switches, routers, and base stations, we strongly recommend using the long-life series (JX/KX/TX series) and avoid choosing standard series (SR/LR/SS/LS/ST/LT series).

Notice: This product is not intended for use in automotive applications.

Features

- Low profile (Height 1.0 mm max.)
- Low ESR (4.5 mΩ to 9 mΩ max.)
- Low ESL (3-terminals : 50% less than 2-terminals) [LR/LS/LT series]
- High ripple current (8500 mA rms max.)
- RoHS compliance, Halogen free

Specifications

Series	SR	LR	SS	LS	ST	LT
Category temp. range	-55 °C to +105 °C					
Rated voltage range	2.0 V to 6.3 V		2.0 V to 2.5 V			
Rated cap. range	68 μF to 220 μF		180 μF to 220 μF		270 μF to 330 μF	
Capacitance tolerance	±20 % (120 Hz / +20 °C)					
DC leakage current	I ≤ 0.1 CV (μA) 2 minutes					
Dissipation factor (tan δ)	≤ 0.06 (120 Hz / +20 °C)					
Surge voltage (V)	Rated voltage × 1.25 (15 °C to 35 °C)					
Endurance	+105 °C 2000 h, rated voltage applied					
	Capacitance change		Within ±20 % of the initial value			
	Dissipation factor (tan δ)		≤ 2 times of the initial limit			
	DC leakage current		≤ 3 times of the initial limit			
Damp heat (Steady state)	+60 °C, 90 % RH, 500 h, No-applied voltage					
	Capacitance change of initial measurd value		2.0 V to 2.5 V		4.0 V	
			+70 %, -20 %		+60 %, -20 %	
	Dissipation factor (tan δ)		≤ 2 times of the initial limit			
DC leakage current		Within the initial limit				

Marking

R. voltage code	Unit : V
d	2.0
e	2.5
g	4.0
j	6.3

Dimensions (not to scale)

2 terminals

3 terminals

SR/SS/ST series

Series	L±0.2	W1±0.2	W2±0.1	H±0.1	P±0.3
SR	7.3	4.3	2.4	1.0 ⁻¹	1.3
SS	7.3	4.3	2.4	1.1	1.3
ST	7.3	4.3	2.4	1.4	1.3

*1: max.

LR/LS/LT series

Series	L±0.2	W1±0.2	W2±0.1	H±0.1	P1±0.3	P2±0.1	P3±0.2	P4±0.2
LR	7.3	4.3	2.4	1.0 ⁻¹	1.3	1.1	0.7	1.4
LS	7.3	4.3	2.4	1.1	1.3	1.1	0.7	1.4
LT	7.3	4.3	2.4	1.4	1.3	1.1	0.7	1.4

*1: max.

* Externals of figure are the reference.

Design and specifications are each subject to change without notice. Ask factory for the current technical specifications before purchase and/or use.

Should a safety concern arise regarding this product, please be sure to contact us immediately.

If delivery specifications suitable for the intended use was not exchanged at the time of product purchase, we will not bear any responsibility.

Explanation of part numbers

◆ Part number system e.g.: EEFSR0D221R4

EEF		SR		0D		221		R4			
Series	Product classification	Series	Code	Rated Voltage (V)	Code	Capacitance (μF)	Code	Capacitance (μF)	Code	ESR (mΩ)	Special code
SR	EEF	SR	SR	2.0	0D	68	680	220	221	4.5	R4
SS		SS	SS	2.5	0E	120	121	270	271	6 (2.0, 2.5 V)	R
ST		ST	ST	4.0	0G	180	181	330	331	9 (4.0, 6.3 V)	
LR		LR	LR	6.3	0J						
LS		LS	LS								
LT		LT	LT								

Characteristics list

Series	Rated voltage (V)	Capacitance (μF)	Case size (mm)			Specification		The number of terminals		Part number	Min. Packaging Qty (pcs)
			L	W	H	Ripple current* ¹ (mA rms)	ESR* ² (mΩ max.)	2	3		
SR	2.0	220	7.3	4.3	1.0 max.	7500	6	○		EEFSR0D221R	3500
			7.3	4.3	1.0 max.	8500	4.5	○		EEFSR0D221R4	3500
	2.5	180	7.3	4.3	1.0 max.	7500	6	○		EEFSR0E181R	3500
			7.3	4.3	1.0 max.	8500	4.5	○		EEFSR0E181R4	3500
	4.0	120	7.3	4.3	1.0 max.	6300	9	○		EEFSR0G121R	3500
	6.3	68	7.3	4.3	1.0 max.	6300	9	○		EEFSR0J680R	3500
LR	2.0	220	7.3	4.3	1.0 max.	7500	6		○	EEFLR0D221R	3500
			7.3	4.3	1.0 max.	8500	4.5		○	EEFLR0D221R4	3500
	2.5	180	7.3	4.3	1.0 max.	7500	6		○	EEFLR0E181R	3500
			7.3	4.3	1.0 max.	8500	4.5		○	EEFLR0E181R4	3500
	4.0	120	7.3	4.3	1.0 max.	6300	9		○	EEFLR0G121R	3500
	6.3	68	7.3	4.3	1.0 max.	6300	9		○	EEFLR0J680R	3500
SS	2.0	220	7.3	4.3	1.1	7500	6	○		EEFSS0D221R	3500
	2.5	180	7.3	4.3	1.1	7500	6	○		EEFSS0E181R	3500
LS	2.0	220	7.3	4.3	1.1	7500	6		○	EEFLS0D221R	3500
	2.5	180	7.3	4.3	1.1	7500	6		○	EEFLS0E181R	3500
ST	2.0	330	7.3	4.3	1.4	7500	6	○		EEFST0D331R	3500
	2.5	270	7.3	4.3	1.4	7500	6	○		EEFST0E271R	3500
LT	2.0	330	7.3	4.3	1.4	7500	6		○	EEFLT0D331R	3500
	2.5	270	7.3	4.3	1.4	7500	6		○	EEFLT0E271R	3500

*1: Ripple current (100 kHz / +45 °C)

*2: ESR (100 kHz / +20 °C)

◆ Please refer to each page in this catalog for "Reflow conditions" and "Taping specifications".

Temperature coefficient of ripple current

Temperature		T ≤ 45 °C	45 °C < T ≤ 85 °C	85 °C < T ≤ 105 °C
2.0 V to 6.3 V	Coefficient	1.0	0.7	0.25

◆ Ripple current should be controlled so that surface temperature of capacitor does not exceed the category temperature.

**Conductive Polymer Aluminum
Electrolytic Capacitors**
Surface Mount Type

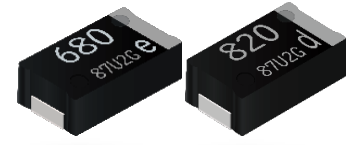

GY series [Super low ESR]

When SP-Cap is designed to be used under constant high load application such as represented in but not limited to the following products such as AI servers, switches, routers, and base stations, we strongly recommend using the long-life series (JX/KX/TX series) and avoid choosing standard series (GY series).

Notice: This product is not intended for use in automotive applications.

Features

- Super low ESR (3 mΩ max.)
- Large capacitance (820 μF max.)
- High ripple current (10200 mA rms max.)
- RoHS compliance, Halogen free

Specifications

Series	GY	
Category temp. range	-55 °C to +105 °C	
Rated voltage range	2.0 V to 2.5 V	
Rated cap. range	680 μF to 820 μF	
Capacitance tolerance	±20 % (120 Hz / +20 °C)	
DC leakage current	I ≤ 0.1 CV (μA) 2 minutes	
Dissipation factor (tan δ)	≤ 0.06 (120 Hz / + 20 °C)	
Surge voltage (V)	Rated voltage × 1.25 (15 °C to 35 °C)	
Endurance	+105 °C 2000 h, rated voltage applied	
	Capacitance change	Within ±20 % of the initial value
	Dissipation factor (tan δ)	≤ 2 times of the initial limit
	DC leakage current	≤ 3 times of the initial limit
Damp heat (Steady state)	+60 °C, 90 % RH, 500 h, No-applied voltage	
	Capacitance change of initial measured value	2.0 V to 2.5 V +70 %, -20 %
	Dissipation factor (tan δ)	≤ 2 times of the initial limit
	DC leakage current	Within the initial limit

Marking

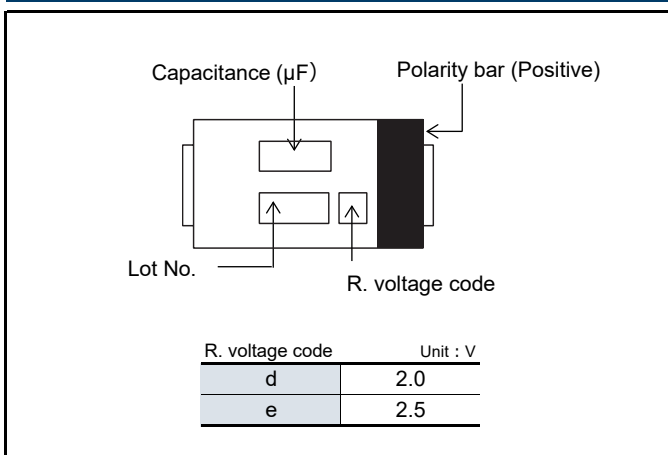

Dimensions (not to scale)

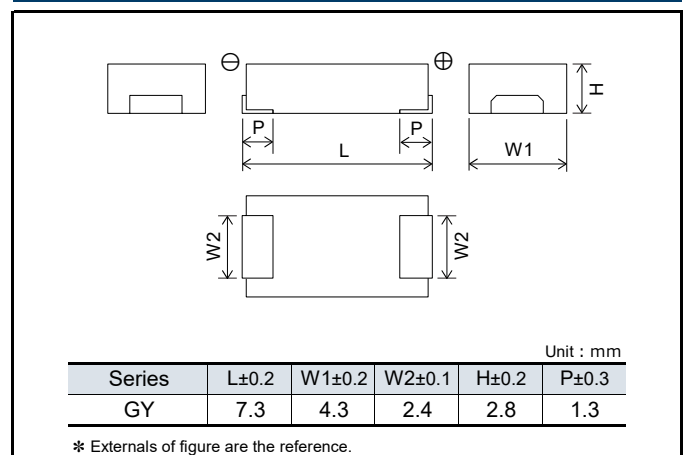

Explanation of part numbers

◇ Part number system e.g.: EEFGY0D821R

EEF		GY		0D		821		R	
Series	Product classification	Series	Code	Rated Voltage (V)	Code	Capacitance (μF)	Code	ESR (mΩ)	Special code
GY	EEF	GY	GY	2.0	0D	680	681	3	R
				2.5	0E	820	821		

Characteristics list

Series	Rated voltage (V)	Capacitance (μF)	Case size (mm)			Specification		Part number	Min. Packaging Q'ty (pcs)
			L	W	H	Ripple current ^{*1} (mA rms)	ESR ^{*2} (mΩ max.)		
GY	2.0	820	7.3	4.3	2.8	10200	3	EEFGY0D821R	2000
	2.5	680	7.3	4.3	2.8	10200	3	EEFGY0E681R	2000

*1: Ripple current (100 kHz / +45 °C)

*2: ESR (100 kHz / +20 °C)

◆ Please refer to each page in this catalog for "Reflow conditions" and "Taping specifications".

Temperature coefficient of ripple current

Temperature		T ≤ 45 °C	45 °C < T ≤ 85 °C	85 °C < T ≤ 105 °C
2.0 V to 2.5 V	Coefficient	1.0	0.7	0.25

◆ Ripple current should be controlled so that surface temperature of capacitor does not exceed the category temperature.

**Conductive Polymer Aluminum
Electrolytic Capacitors**
Surface Mount Type

CY/SY series [Guaranteed at 85 °C]

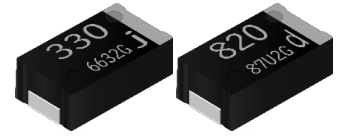

When SP-Cap is designed to be used under constant high load application such as represented in but not limited to the following products such as AI servers, switches, routers, and base stations, we strongly recommend using the long-life series (JX/KX/TX series) and avoid choosing standard series (CY/SY series).

Notice: This product is not intended for use in automotive applications.

Features

- Endurance 85 °C 2000 h
- Product height (3.0 mm max.)
- High ripple current (5100 mA rms to 6300 mA rms max.)
- RoHS compliance, Halogen free

Specifications

Series	CY / SY		
Category temp. range	-55 °C to +85 °C		
Rated voltage range	4.0 V, 6.3V		
Rated cap. range	330 μF to 470 μF		
Capacitance tolerance	±20 % (120 Hz / +20 °C)		
DC leakage current	I ≤ 0.1 CV (μA) 2 minutes		
Dissipation factor (tan δ)	≤ 0.06 (120 Hz / + 20 °C)		
Surge voltage (V)	Rated voltage × 1.25 (15 °C to 35 °C)		
Endurance	+85 °C 2000 h, rated voltage applied		
	Capacitance change	Within ±20 % of the initial value	
	Dissipation factor (tan δ)	≤ 2 times of the initial limit	
	DC leakage current	≤ 3 times of the initial limit	
Damp heat (Steady state)	+60 °C, 90 % RH, 500 h, No-applied voltage		
	Capacitance change of initial measurd value	4.0 V	6.3 V
		+60 %, -20 %	+50 %, -20 %
	Dissipation factor (tan δ)	≤ 2 times of the initial limit	
DC leakage current	Within the initial limit		

Marking

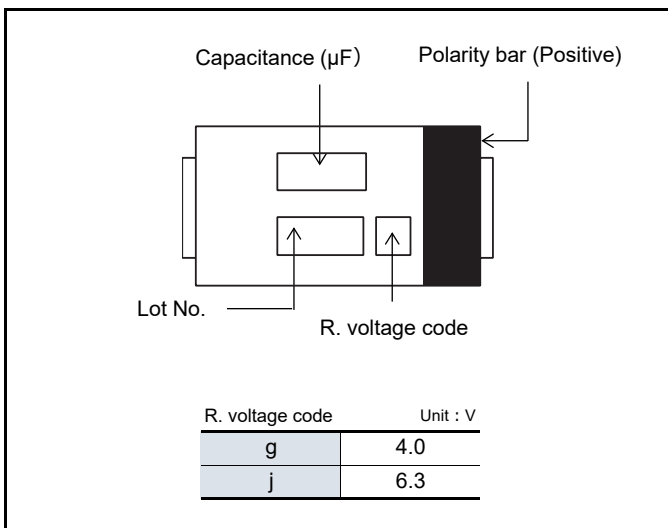

Dimensions (not to scale)

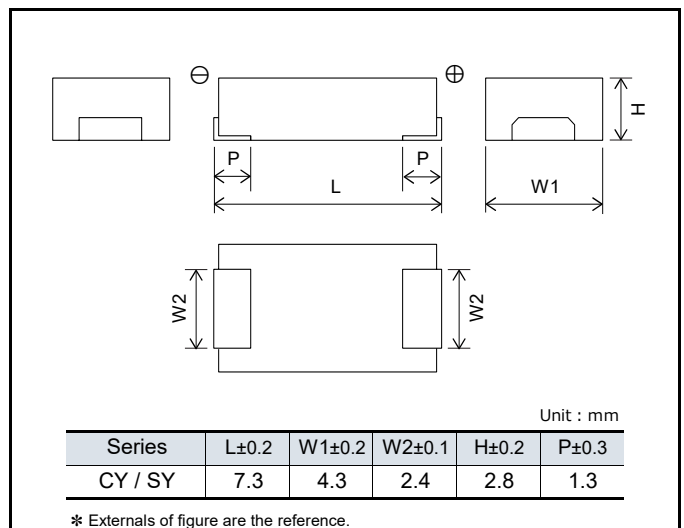

Explanation of part numbers

◇ Part number system e.g.: ECGCY0G471R

ECG		CY		0G		471		R	
Series	Product classification	Series	Code	Rated Voltage (V)	Code	Capacitance (μF)	Code	ESR (mΩ)	Special code
CY	ECG	CY	CY	4.0	0G	330	331	9, 15	R
SY		SY	SY	6.3	0J	470	471		

Characteristics list

Series	Rated voltage (V)	Capacitance (μF)	Case size (mm)			Specification		Part number	Min. Packaging Q'ty (pcs)
			L	W	H	Ripple current* ¹ (mA rms)	ESR* ² (mΩ max.)		
CY	4.0	470	7.3	4.3	2.8	5100	15	ECGCY0G471R	2000
	6.3	330	7.3	4.3	2.8	5100	15	ECGCY0J331R	2000
SY	4.0	470	7.3	4.3	2.8	6300	9	ECGSY0G471R	2000
	6.3	330	7.3	4.3	2.8	6300	9	ECGSY0J331R	2000

*1: Ripple current (100 kHz / +45 °C)

*2: ESR (100 kHz / +20 °C)

◆ Please refer to each page in this catalog for "Reflow conditions" and "Taping specifications".

Temperature coefficient of ripple current

Temperature		T ≤ 45 °C	45 °C < T ≤ 65 °C	65 °C < T ≤ 85 °C
4.0 V to 6.3 V	Coefficient	1.0	0.7	0.25

◆ Ripple current should be controlled so that surface temperature of capacitor does not exceed the category temperature.

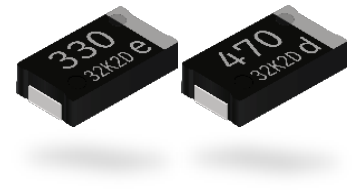

Conductive Polymer Aluminum Electrolytic Capacitors

Surface Mount Type

HX series [Guaranteed at 125 °C]

When SP-Cap is designed to be used under constant high load application such as represented in but not limited to the following products such as AI servers, switches, routers, and base stations, we strongly recommend using the long-life series (JX/KX/TX series) and avoid choosing standard series (HX series).

Notice: This product is not intended for use in automotive applications.

Features

- Endurance 125 °C 1000 h
- High voltage & Large capacitance (2.0 V / 470 μF to 25 V / 33 μF)
- Low ESR (4.5 mΩ max.)
- RoHS compliance, Halogen free

Specifications

Series	HX	
Category temp. range	-55 °C to +125 °C	
Rated voltage range	2.0 V to 2.5 V, 10 V to 25 V	
Category voltage range	1.6 V to 2.0 V, 8.0 V to 20 V	
Rated cap. range	15 μF to 470 μF	
Capacitance tolerance	±20 % (120 Hz / +20 °C)	
DC leakage current	I ≤ 0.1 CV(μA) [2.0 V to 2.5 V, 2 min], I ≤ 0.3 CV(μA) [10 V to 25 V, 2 min]	
Dissipation factor (tan δ)	≤ 0.1 (120 Hz / +20 °C)	
Surge voltage (V)	Rated voltage × 1.25 [2.0 V to 16 V], × 1.15 [20 V to 25 V] (15 °C to 35 °C)	
Endurance	+125 °C 1000 h, category voltage applied	
	Capacitance change	Within ±20 % of the initial value
	Dissipation factor (tan δ)	≤ 2 times of the initial limit
	DC leakage current	Within the initial limit
Damp heat (Steady state)	After storing for 500 hours at +60 °C, 90 % RH	
	Capacitance change of initial measured value	2.0 V to 2.5 V : +70 %, -20 % 10 V to 25 V : +60 %, -20 %
	Dissipation factor (tan δ)	≤ 2 times of the initial limit
	DC leakage current	Within the initial limit : 2.0 V to 2.5 V ≤ 3 times of the initial limit : 10 V to 25 V

Marking

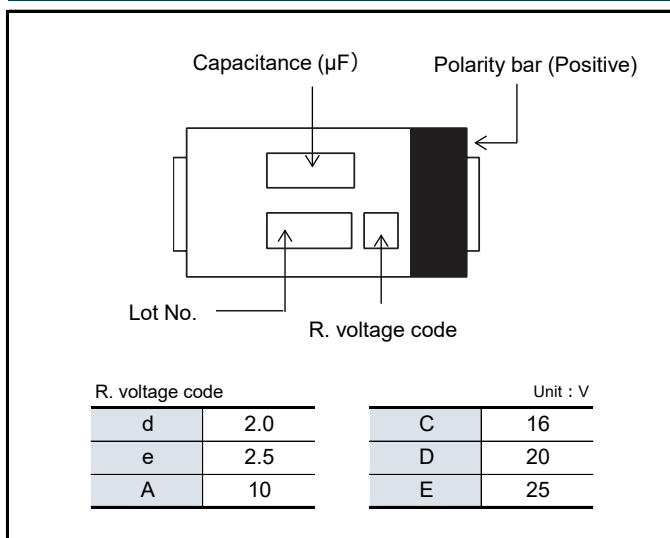

Dimensions (not to scale)

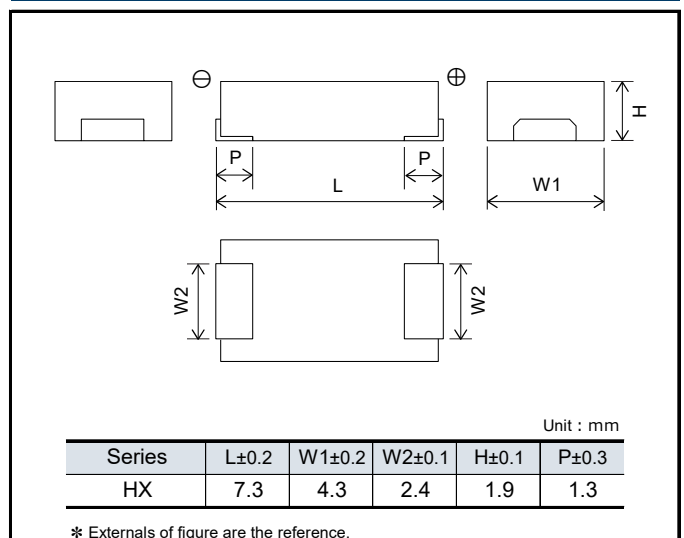

Explanation of part numbers

◇ **Part number system** e.g.: EEFHX0D471R9

EEF		HX		0D		471		R9			
Series	Product classification	Series	Code	Rated Voltage (V)	Code	Capacitance (μF)	Code	Capacitance (μF)	Code	ESR (mΩ)	Special Code
HX	EEF	HX	HX	2.0	0D	15	150	68	680	15 (2.0, 2.5 V)	R
				2.5	0E	22	220	100	101	40 (10 to 25 V)	
				10	1A	33	330	330	331	4.5	R4
				16	1C	47	470	470	471	6	R6
				20	1D	56	560			9	R9
				25	1E						

Characteristics list

■ **2.0 V to 2.5 V**

Series	Rated voltage [105 °C] (V)	Category voltage [125 °C] (V)	Capacitance (μF)	Case size (mm)			Specification		Part number	Min. Packaging Qty (pcs)
				L	W	H	Ripple current*1 (mA rms)	ESR*2 (mΩ max.)		
HX	2.0	1.6	470	7.3	4.3	1.9	5100	15	EEFHX0D471R	3500
				7.3	4.3	1.9	6300	9	EEFHX0D471R9	3500
				7.3	4.3	1.9	7500	6	EEFHX0D471R6	3500
				7.3	4.3	1.9	8500	4.5	EEFHX0D471R4	3500
	2.5	2.0	330	7.3	4.3	1.9	5100	15	EEFHX0E331R	3500
				7.3	4.3	1.9	6300	9	EEFHX0E331R9	3500
				7.3	4.3	1.9	7500	6	EEFHX0E331R6	3500
				7.3	4.3	1.9	8500	4.5	EEFHX0E331R4	3500
			470	7.3	4.3	1.9	5100	15	EEFHX0E471R	3500
				7.3	4.3	1.9	6300	9	EEFHX0E471R9	3500
				7.3	4.3	1.9	7500	6	EEFHX0E471R6	3500
				7.3	4.3	1.9	8500	4.5	EEFHX0E471R4	3500

■ **10 V to 25 V**

Not Recommended for New Design

For replacement

Series	Rated voltage [105 °C] (V)	Category voltage [125 °C] (V)	Capacitance (μF)	Case size (mm)			Specification		Part number	Min. Packaging Qty (pcs)
				L	W	H	Ripple current*1 (mA rms)	ESR*2 (mΩ max.)		
HX	10	8.0	47	7.3	4.3	1.9	3200	40	EEFHX1A470R	3500
			68	7.3	4.3	1.9	3200	40	EEFHX1A680R	3500
			100	7.3	4.3	1.9	3200	40	EEFHX1A101R	3500
	16	12.8	15	7.3	4.3	1.9	3200	40	EEFHX1C150R	3500
			22	7.3	4.3	1.9	3200	40	EEFHX1C220R	3500
			33	7.3	4.3	1.9	3200	40	EEFHX1C330R	3500
			47	7.3	4.3	1.9	3200	40	EEFHX1C470R	3500
	20	16	68	7.3	4.3	1.9	3200	40	EEFHX1C680R	3500
			22	7.3	4.3	1.9	3200	40	EEFHX1D220R	3500
			33	7.3	4.3	1.9	3200	40	EEFHX1D330R	3500
			47	7.3	4.3	1.9	3200	40	EEFHX1D470R	3500
	25	20	56	7.3	4.3	1.9	3200	40	EEFHX1D560R	3500
			15	7.3	4.3	1.9	3200	40	EEFHX1E150R	3500
			22	7.3	4.3	1.9	3200	40	EEFHX1E220R	3500
			33	7.3	4.3	1.9	3200	40	EEFHX1E330R	3500

*1: Ripple current (100 kHz / +45 °C) *2: ESR (100 kHz / +20 °C)

◆ Please refer to each page in this catalog for "Reflow conditions" and "Taping specifications".

Temperature coefficient of ripple current

Temperature		T ≤ 45 °C	45 °C < T ≤ 85 °C	85 °C < T ≤ 105 °C	105 °C < T ≤ 125 °C
2.0 V to 2.5 V	Coefficient	1.0	0.7	0.25	0.25
10 V to 25 V		1.0	0.8	0.5	0.25

◆ Ripple current should be controlled so that surface temperature of capacitor does not exceed the category temperature.

Design and specifications are each subject to change without notice. Ask factory for the current technical specifications before purchase and/or use. Should a safety concern arise regarding this product, please be sure to contact us immediately. If delivery specifications suitable for the intended use was not exchanged at the time of product purchase, we will not bear any responsibility.

Replacement list for “Not recommended for new design”

* If you are using any of the following models on the deleted list, please substitute them with the suggested alternative model as soon as possible.

Non-recommended part number					Replacement part number								
Series	Cate-gory temp. range max. (°C)	Rated voltage (V)	Capaci-tance (μF)	ESR (mΩ)	Part number	Series	Size code	Cate-gory temp. range max. (°C)	Rated voltage (V)	Capaci-tance (μF)	ESR (mΩ)	Part number	
CS	105	10	47	40	EEFCS1A470R	POSCAP TQC	D15	105	16	47	55	16TQC47MYFT	
						POSCAP TPE	B2	85	10	47	35	10TPE47MAZB	
						OS-CON SVP	C6	105	10	47	50	10SVP47M	
						Hybrid ZA	D	105	25	47	50	EEHZA1E470P	
	105	16	15	40	EEFCS1C150R	POSCAP TQC	D15	105	16	47	55	16TQC47MYFT	
						OS-CON SVP	B6	105	16	22	90	16SVP22M	
						Hybrid ZA	C	105	25	22	80	EEHZA1E220R	
	105	16	22	40	EEFCS1C220R	POSCAP TQC	D15	105	16	47	55	16TQC47MYFT	
						OS-CON SVP	B6	105	16	22	90	16SVP22M	
						Hybrid ZA	C	105	25	22	80	EEHZA1E220R	
	105	16	33	40	EEFCS1C330R	POSCAP TQC	D15	105	16	47	55	16TQC47MYFT	
						OS-CON SVPC	B6	105	16	39	27	16SVPC39MV	
						Hybrid ZA	C	105	25	33	80	EEHZA1E330R	
	105	20	10	40	EEFCS1D100R	POSCAP TQC	D15	105	20	47	55	20TQC47MYFT	
						OS-CON SVPA	B6	105	20	10	40	20SVPA10M	
						Hybrid ZA	C	105	35	10	100	EEHZA1V100R	
	105	20	15	40	EEFCS1D150R	POSCAP TQC	D15	105	20	47	55	20TQC47MYFT	
						OS-CON SVPA	C6	105	20	22	35	20SVPA22M	
						Hybrid ZA	C	105	25	22	80	EEHZA1E220R	
	105	20	22	40	EEFCS1D220R	POSCAP TQC	D15	105	20	47	55	20TQC47MYFT	
						OS-CON SVPA	C6	105	20	22	35	20SVPA22M	
						Hybrid ZA	C	105	25	22	80	EEHZA1E220R	
	105	25	10	40	EEFCS1E100R	POSCAP TQC	D2	105	25	22	60	25TQC22MD2	
						POSCAP TQS	D15	105	35	47	100	35TQS47MEX	
POSCAP TQC						D2	105	25	15	90	25TQC15MD2		
OS-CON SVPD						C6	125	25	10	65	25SVPD10M		
Hybrid ZA						C	105	35	10	100	EEHZA1V100R		
105	25	15	40	EEFCS1E150R	POSCAP TQC	D2	105	25	22	60	25TQC22MD2		
					POSCAP TQS	D15	105	35	47	100	35TQS47MEX		
					POSCAP TQC	D2	105	25	15	90	25TQC15MD2		
					OS-CON SVPK	B6	125	25	33	35	25SVPK33M		
105	35	10	40	EEFCS1V100R	Hybrid ZA	C	105	25	22	80	EEHZA1E220R		
					POSCAP TQC	D2	105	35	10	180	35TQC10MD2		
					OS-CON SVPK	B6	125	35	22	35	35SVPK22M		
CT	105	10	68	40	EEFCT1A680R	POSCAP TQC	D15	105	16	47	55	16TQC47MYFT	
						POSCAP TPC	D2	105	10	100	45	10TPC100M	
						OS-CON SVPC	B6	105	10	68	30	10SVPC68M	
						Hybrid ZA	D8	105	25	68	30	EEHZA1E680XP	
						Hybrid ZA	D8	105	35	68	35	EEHZA1V680XP	
	105	16	47	40	EEFCT1C470R	POSCAP TQC	D15	105	16	47	55	16TQC47MYFT	
						OS-CON SVF	B6	125	16	82	27	16SVF82M	
						Hybrid ZA	D	105	25	47	50	EEHZA1E470P	
	105	20	33	40	EEFCT1D330R	POSCAP TQC	D15	105	20	47	55	20TQC47MYFT	
						OS-CON SVPK	B6	125	25	33	35	25SVPK33M	
						Hybrid ZA	C	105	25	33	80	EEHZA1E330R	
	105	20	47	40	EEFCT1D470R	POSCAP TQC	D15	105	20	47	55	20TQC47MYFT	
						OS-CON SVPF	C6	105	25	47	30	25SVPF47M	
						Hybrid ZA	D	105	25	47	50	EEHZA1E470P	
	105	25	22	40	EEFCT1E220R	POSCAP TQC	D15	105	25	22	70	25TQC22MD2	
						POSCAP TQS	D15	105	35	47	100	35TQS47MEX	
						OS-CON SVPF	B6	105	25	27	40	25SVPF27MX	
						Hybrid ZA	C	105	25	22	80	EEHZA1E220R	
	105	35	15	40	EEFCT1V150R	POSCAP TQC	D2	105	35	15	150	35TQC15MD2	
						OS-CON SVPK	B6	125	35	22	35	35SVPK22M	
							Hybrid ZA	C	105	35	22	100	EEHZA1V220R

Replacement list for “Not recommended for new design”

* If you are using any of the following models on the deleted list, please substitute them with the suggested alternative model as soon as possible.

Non-recommended part number					Replacement part number							
Series	Cate-gory temp. range max. (°C)	Rated voltage (V)	Capaci-tance (μF)	ESR (mΩ)	Part number	Series	Size code	Cate-gory temp. range max. (°C)	Rated voltage (V)	Capaci-tance (μF)	ESR (mΩ)	Part number
CX	105	10	100	40	EEFCX1A101R	POSCAP TPC	D2	105	10	100	45	10TPC100M
						OS-CON SVPC	C6	105	10	120	22	10SVPC120MV
						Hybrid ZA	D8	105	25	100	30	EEHZA1E101XP
	105	10	47	40	EEFCX1A470R	POSCAP TPE	D2E	105	10	68	25	10TPC100M
						POSCAP TPE	B2	85	10	47	35	10TPE47MAZB
						OS-CON SVP	C6	105	10	47	50	10SVP47M
	105	10	68	40	EEFCX1A680R	Hybrid ZA	D	105	25	47	50	EEHZA1E470P
						POSCAP TPC	D2	105	10	100	45	10TPC100M
						POSCAP TQC	D2	105	16	68	50	16TQC68MD2
						OS-CON SVPC	B6	105	10	68	23	10SVPC68MV
	105	16	15	40	EEFCX1C150R	Hybrid ZA	D8	105	25	68	30	EEHZA1E680XP
						Hybrid ZA	D8	105	35	68	35	EEHZA1V680XP
						POSCAP TQC	D2	105	16	47	55	16TQC47MD2
						POSCAP TQC	B2	105	25	15	100	25TQC15MB
	105	16	22	40	EEFCX1C220R	OS-CON SVP	B6	105	16	22	90	16SVP22M
						Hybrid ZA	C	105	25	22	80	EEHZA1E220R
						POSCAP TQC	B2	105	16	33	90	16TQC33MB2
	105	16	33	40	EEFCX1C330R	OS-CON SVPC	B6	105	16	39	27	16SVPC39MV
						Hybrid ZA	C	105	25	33	80	EEHZA1E330R
						OS-CON SVPF	B6	105	16	82	27	16SVPF82M
	105	16	47	40	EEFCX1C470R	Hybrid ZA	D	105	25	47	50	EEHZA1E470P
						POSCAP TQC	D2	105	16	68	50	16TQC68MD2
	105	16	68	40	EEFCX1C680R	POSCAP TQC	D2	105	16	100	50	16TQC100MD2
						OS-CON SVPC	C6	105	16	68	25	16SVPC68MV
						Hybrid ZA	D8	105	25	68	30	EEHZA1E680XP
						Hybrid ZA	D8	105	35	68	35	EEHZA1V680XP
	105	20	22	40	EEFCX1D220R	POSCAP TQC	D2	105	20	33	60	20TQC33MD2
						POSCAP TQC	B2	105	20	22	90	20TQC22MB2
						OS-CON SVPA	C6	105	20	22	35	20SVPA22M
						Hybrid ZA	C	105	25	22	80	EEHZA1E220R
	105	20	33	40	EEFCX1D330R	POSCAP TQC	D2	105	20	33	60	20TQC33MD2
						POSCAP TQC	D2	105	20	47	55	20TQC47MD2
						OS-CON SVPK	B6	125	25	33	35	25SVPK33M
	105	20	47	40	EEFCX1D470R	Hybrid ZA	C	105	25	33	80	EEHZA1E330R
						POSCAP TQC	D15	105	20	47	55	20TQC47MYFT
						OS-CON SVPF	C6	105	25	47	30	25SVPF47M
	105	20	56	40	EEFCX1D560R	Hybrid ZA	D	105	25	47	50	EEHZA1E470P
						POSCAP TQC	D2	105	20	100	100	20TQC100MD2
	105	25	15	40	EEFCX1E150R	OS-CON SVPF	B6	105	20	56	30	20SVPF56MX
						Hybrid ZA	C	105	25	56	50	EEHZA1E560P
						POSCAP TQC	B2	105	25	15	100	25TQC15MB
	105	25	22	40	EEFCX1E220R	OS-CON SVPK	B6	125	25	33	35	25SVPK33M
						Hybrid ZA	C	105	25	22	80	EEHZA1E220R
						POSCAP TQC	D2	105	25	22	60	25TQC22MD2
	105	25	33	40	EEFCX1E330R	OS-CON SVPF	B6	105	25	27	40	25SVPF27M
						Hybrid ZA	C	105	25	22	80	EEHZA1E220R
						POSCAP TQC	D2	105	25	22	60	25TQC22MD2
	105	35	15	40	EEFCX1V150R	OS-CON SVPK	B6	125	25	33	35	25SVPK33M
Hybrid ZA						C	105	25	33	80	EEHZA1E330R	
POSCAP TQC						D2	105	35	15	150	35TQC15MD2	
105	35	22	40	EEFCX1V220R	OS-CON SVPK	B6	125	35	22	35	35SVPK22M	
					Hybrid ZA	C	105	35	22	100	EEHZA1V220R	
					POSCAP TQC	D2	105	35	15	150	35TQC15MD2	
												35SVPK22M
												EEHZA1V220R

Replacement list for “Not recommended for new design”

* If you are using any of the following models on the deleted list, please substitute them with the suggested alternative model as soon as possible.

Non-recommended part number					Replacement part number							
Series	Cate-gory temp. range max. (°C)	Rated voltage (V)	Capaci-tance (μF)	ESR (mΩ)	Part number	Series	Size code	Cate-gory temp. range max. (°C)	Rated voltage (V)	Capaci-tance (μF)	ESR (mΩ)	Part number
HX	125	10	47	40	EEFHX1A470R	POSCAP TDC	D2	125	16	100	50	16TDC100MD2
						OS-CON SVPD	C6	125	10	56	45	10SVPD56M
						Hybrid ZC	D	125	25	47	50	EEHZC1E470P
	125	10	68	40	EEFHX1A680R	POSCAP TDC	D2	125	16	100	50	16TDC100MD2
						OS-CON SVPK	B6	125	20	68	30	20SVPK68M
						Hybrid ZC	D8	125	25	68	30	EEHZC1E680XP
	125	10	100	40	EEFHX1A101R	POSCAP TDC	D2	125	16	100	50	16TDC100MD2
						POSCAP TCF	D3L	105	10	150	15	10TCF150ML
						OS-CON SVPK	B6	125	16	100	27	16SVPK100M
	125	16	15	40	EEFHX1C150R	Hybrid ZC	D8	125	25	100	30	EEHZC1E101XP
						POSCAP TDC	D2	125	16	100	50	16TDC100MD2
						POSCAP TDC	B2	125	16	33	90	16TDC33MB2
	125	16	22	40	EEFHX1C220R	Hybrid ZC	C	125	25	22	80	EEHZC1E220R
						POSCAP TDC	D2	125	16	100	50	16TDC100MD2
						POSCAP TDC	B2	125	16	33	90	16TDC33MB2
	125	16	33	40	EEFHX1C330R	OS-CON SVPK	B6	125	35	22	35	35SVPK22M
						Hybrid ZC	C	125	25	22	80	EEHZC1E220R
						POSCAP TDC	D2	125	16	100	50	16TDC100MD2
	125	16	47	40	EEFHX1C470R	POSCAP TDC	B2	125	16	33	90	16TDC33MB2
						OS-CON SVPK	B6	125	25	33	35	25SVPK33M
						Hybrid ZC	C	125	25	33	80	EEHZC1E330R
	125	16	68	40	EEFHX1C680R	POSCAP TDC	D2	125	16	100	50	16TDC100MD2
						OS-CON SVF	B6	125	16	82	27	16SVF82M
						Hybrid ZC	D8	125	25	68	30	EEHZC1E680XP
	125	20	22	40	EEFHX1D220R	POSCAP TDC	B2	125	20	22	90	20TDC22MB2
						OS-CON SVPK	B6	125	35	22	35	35SVPK22M
						Hybrid ZC	C	125	25	22	80	EEHZC1E220R
	125	20	33	40	EEFHX1D330R	OS-CON SVPK	B6	125	25	33	35	25SVPK33M
						Hybrid ZC	C	125	25	33	80	EEHZC1E330R
	125	20	47	40	EEFHX1D470R	OS-CON SVPK	C6	125	35	47	27	35SVPK47M
						Hybrid ZC	D	125	25	47	50	EEHZC1E470P
	125	20	56	40	EEFHX1D560R	OS-CON SVF	B6	125	20	56	30	20SVF56M
						Hybrid ZC	D	125	25	56	50	EEHZC1E560P
	125	25	15	40	EEFHX1E150R	POSCAP TDC	D3L	125	25	68	70	25TDC68MD3
						POSCAP TDC	B2	125	25	15	100	25TDC15MB
						OS-CON SVF	B6	125	25	27	40	25SVF27M
						Hybrid ZC	C	125	25	22	80	EEHZC1E220R
	125	25	22	40	EEFHX1E220R	POSCAP TDC	D3L	125	25	68	70	25TDC68MD3
						OS-CON SVF	B6	125	25	27	40	25SVF27M
						Hybrid ZC	C	125	25	22	80	EEHZC1E220R
	125	25	33	40	EEFHX1E330R	POSCAP TDC	D3L	125	25	68	70	25TDC68MD3
						OS-CON SVPK	B6	125	25	33	35	25SVPK33M
Hybrid ZC						C	125	25	33	80	EEHZC1E330R	

Conductive Polymer Tantalum Solid Capacitors

POSCAP™

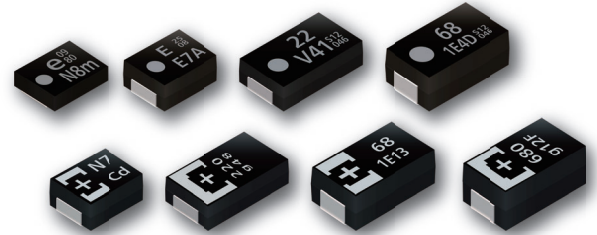

INDEX

Application Guidelines (POSCAP)	P48
Line-up / Diagram	P50
Voltage - Capacitance table	P53
Explanation of part numbers	P57
Mounting / Packing specifications	P58
Each series	P60
Catalog Deletion Models / EOL Models	P87

Applications

Main market

Laptop computer

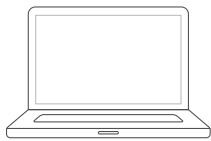

Communications infrastructure

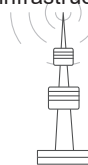

SSD, HDD



Audio / Visual

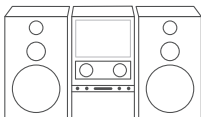

Server



Automotive

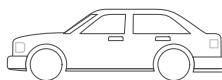

Industrial robot

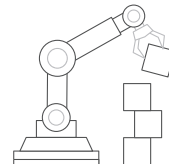

Drone



Matters to Be Observed When Using This Product (Conductive Polymer Tantalum Solid Capacitors / POSCAP)

Use environments and cleaning conditions

- This product (capacitor) is intended for standard general-purpose use in electronic equipment, and is not designed for use in the specific environments described below. Using the product in such specific environments or service conditions, therefore, may affect the performance of the product.

Please check with us about the performance and reliability of the product first before using the product.

- (1) Used in liquid, such as water, oil, chemicals, and organic solvents.
 - (2) Used in a place exposed to direct sunlight, an outdoor place with no shielding, or a dusty place.
 - (3) Used in a wet place (dew concentration on a resistor, water leakage, etc.), a place exposed to sea breeze, or a place filled with a corrosive gas, such as Cl_2 , H_2S , NH_3 , SO_2 , or NO_x .
 - (4) Used in an environment where static electricity and electromagnetic waves are strong.
 - (5) The product is located close to a heating component or a flammable material, such as a vinyl cable, is placed near the product.
 - (6) The product is used sealed with a resin, etc.
 - (7) Solder flux of the soldered product is cleansed with a solvent, water, and a water-soluble cleaner.
(Be careful with water soluble solder flux.)
 - (8) Used in an environment where an acidic or alkali atmosphere is present.
 - (9) Used in an environment where excessive vibration or impact is applied to the product.
 - (10) Used under a low atmospheric pressure condition or depressurized condition.
- When the capacitor is used in a circuit where an impact voltage is applied or a high voltage is applied in a short period (transient phenomenon) or a high pulse voltage is applied, make sure to use the capacitor at a voltage equal to or lower than its rated voltage.

Response to anomalies and handling conditions

- A short mode is a major failure mode in a capacitor. A short mode is caused by thermal stress created by soldering or a high service temperature, electric stress, mechanical stress, etc. When the capacitor has shorted, take the following steps to ensure your safety.
 - (1) When you see smoke coming out of the shorted product, turn off the main power supply to stop using the capacitor.
Do not place your face or hand near to the smoldering capacitor.
 - (2) The time a shorted capacitor takes to generate smoke ranges from a few seconds to a few minutes, depending on service conditions. If you incorporate a protective circuit, design the circuit to activate in the time preceding the smoke generation.
 - (3) In case smoke gets into your eyes or comes into your mouth, wash the eyes with water or rinse out the mouth immediately.
 - (4) When a current value after the short of the product is extremely large, the shorted capacitor may spark out, which, in the worst scenario, may result in ignition. Ensure the safety of the circuit by, for example, giving it a redundant circuit structure or providing it with a protective circuit.

Reliability and product life

The failure rate of the capacitor is specified based on $0.5\% \cdot 1000 \text{ h}$ (reliability level 60%), a failure rate conforming to JIS C 5003 (failure rate level). This indicates that the possibility of occurrence of a failure is by no means zero. One of the failure modes is a wear out failure. This happens when the period of guaranteeing the durability and high-temperature/high-humidity resistance of the capacitor is over, changes in the electrical characteristics of the capacitor (product) get larger and its electrolyte gradually deteriorates into an insulating material to create an open mode. Another failure mode is a random failure in which a short mode results mainly because of thermal, electrical, or mechanical stress, etc.

* The failure rate of a small POSCAP of a B2 size or smaller is 1.0%.

Circuit design and circuit board design

- Do not use this capacitor in a high-impedance voltage holding circuit, a coupling circuit, a time constant circuit, or a circuit widely affected by leak current.
- The capacitor is incorporated and used in a circuit where the capacitor operates within a rating range specified in the specifications. Set a service temperature within a specified category temperature range. Do not let a current larger than the allowable ripple current flow in the circuit. Reduce a ripple current to the extent at which the surface temperature of the capacitor's top does not exceed the rated temperature.
(For information about TQC series, please contact us separately.)
- Electrical characteristics values listed in a characteristics table, such as a capacitance and an ESR, are values specified at shipment of the capacitor. These values may change when departing from the specified values in the table under certain electrical or mechanical performance condition. Be careful in choosing a capacitor with the intended electrical characteristics in your design work. Besides, temperature/frequency fluctuations can cause the capacitor's electrical characteristics to change. Confirm such changes in the electrical characteristics and then proceed with your circuit design.
- A leak current may increase even when soldering conditions are within a specified range. The leak current may increase also in a high-temperature non-load test or humidity-resistance non-load test, in which no voltage is applied, a temperature cycle test, etc. In such cases, applying a voltage at a temperature equal to or lower than the highest service temperature of the capacitor reduces the leak current gradually.
- A flow of excessively large rush current created by rapid charge/discharge may result in short circuit or an increase in leak current. When a rush current value exceeds 20 A*, apply a protective circuit to the product.
Note that at leak current measurement, a protective resistance of about 1 kΩ is put in the circuit before the capacitance is charged or discharges.

Mounting and storage conditions

- Set soldering conditions within a specified range. Stricter soldering conditions outside the specified range will cause the deterioration of the electrical characteristics and service life characteristics.
- The capacitor must be kept in storage in an environment that avoids dropping soldering performance or caused trouble with soldering because of moisture absorption by an exterior resin. Store the capacitor, which is put together with a reel in an airtight moisture-proof bag, in a place where a normal temperature and humidity (15 °C to 35 °C and 45%RH to 75%RH) are maintained and direct sunlight is blocked. The storage period is 18 months or less after shipment from the factory.
- Unseal the bag to take out the capacitor right before mounting it on a circuit. Once you take out the capacitor, make sure to use it up. Storage periods for capacitors taken out of bags are as follows.

* These products do not conform to the entire requirements defined in JEDEC J-STD-020 and J-STD-033.

- (1) Level 2a : four weeks at a temperature and a humidity equal to or lower than 30 °C and 60 %RH
- (2) Level 3 : 168 hours at a temperature and a humidity equal to or lower than 30 °C and 60 %RH
- (3) Level 5 : 48 hours at a temperature and a humidity equal to or lower than 30 °C and 60 %RH

Reference information

Intellectual property

Panasonic Group provides customers with safe products and services. We are also making great efforts to protect our intellectual property rights for Panasonic Group products. Typical patents related to this product are as follows.

[U.S. patent]

USP Nos. 8081421, 8149569, 8456804, and 8559166

Line up

Series	Features	Small size/Low profile	Large capacitance	Low ESR	High reliability	High voltage	Guaranteed at 125°C	Category temp. range (°C)	Rated voltage (V)	ESR (mΩ)	Capacitance (μF)	Size code	Size (mm)		
													L	W	H
TPS	Small size/Low profile Large capacitance Face down terminal	●	●					-55 to 105	2.5 to 6.3	30 to 35	150 to 330	B1S	3.5	2.8	1.1
TPSF	Low ESR/Small size Large capacitance Face down terminal	●	●	●				-55 to 105	2.0 to 2.5	6 to 9	270	B2S	3.5	2.8	1.9
TPE*1	Low ESR							-55 to 105	2.0 to 10	9 to 70	47 to 470	B2	3.5	2.8	1.9
								-55 to 105	2.5 to 10	7 to 45	68 to 470	D2E	7.3	4.3	1.8
								-55 to 105	2.5 to 10	9 to 40	150 to 680	D3L	7.3	4.3	2.8
								-55 to 105	2.5 to 10	10 to 40	330 to 1500	D4	7.3	4.3	3.8
TPF*1	Low ESR Large capacitance							-55 to 105	2.5 to 10	5 to 25	150 to 680	D3L	7.3	4.3	2.8
								-55 to 105	2.5 to 6.3	5 to 35	470 to 1000	D4	7.3	4.3	3.8
TQT	Super high voltage Low profile Large capacitance	●	●					-55 to 105	35	100	56	D15S	7.3	4.3	1.4
TQS	High voltage	●						-55 to 105	35	100	47	D15S	7.3	4.3	1.4
								-55 to 105	35	100	68	D2S	7.3	4.3	1.9
UPDATE	High voltage							-55 to 105	16 to 35	90 to 200	10 to 47	B2	3.5	2.8	1.9
								-55 to 105	16 to 25	55 to 70	22 to 47	D15	7.3	4.3	1.4
								-55 to 105	16 to 35	50 to 180	10 to 150	D2	7.3	4.3	1.9
								-55 to 105	16 to 25	50 to 70	68 to 220	D3L	7.3	4.3	2.8
TA	High reliability							-55 to 105	4.0 to 10	70	47 to 100	B2	3.5	2.8	1.9
								-55 to 105	2.5 to 6.3	9 to 25	150 to 470	D2E	7.3	4.3	1.8
								-55 to 105	2.5 to 10	15 to 25	150 to 680	D3L	7.3	4.3	2.8
TV	High reliability Guaranteed at 125 °C							-55 to 125	6.3 to 10	25	68 to 150	D2E	7.3	4.3	1.8
								-55 to 125	10	25	150	D3L	7.3	4.3	2.8
TPB*1	Standard							-55 to 105	4.0 to 10	70	33 to 68	B2	3.5	2.8	1.9
								-55 to 105	4.0 to 10	40 to 55	150 to 330	D3L	7.3	4.3	2.8
								-55 to 105	6.3 to 10	35 to 40	220 to 470	D4	7.3	4.3	3.8

*1 : Some part numbers are not a recommended product

Line up

Series	Features	Small size/Low profile	Large capacitance	Low ESR	High reliability	High voltage	Guaranteed at 125°C	Category temp. range (°C)	Rated voltage (V)	ESR (mΩ)	Capacitance (μF)	Size code	Size (mm)		
													L	W	H
NRFND TH	Guaranteed at 125 °C						●	-55 to 125	2.5 to 6.3	15 to 25	150 to 330	D2E	7.3	4.3	1.8
								-55 to 125	2.5 to 10	40 to 45	68 to 220	D2	7.3	4.3	1.9
								-55 to 125	4.0 to 6.3	40	220 to 330	D3L	7.3	4.3	2.8
								-55 to 125	6.3 to 10	35 to 40	220 to 470	D4	7.3	4.3	3.8
TC ^{*1}	Guaranteed at 125 °C						●	-55 to 125	2.5	9	330	B2	3.5	2.8	1.9
								-55 to 125	4.0 to 6.3	15 to 25	100 to 330	D2E	7.3	4.3	1.8
								-55 to 125	2.5 to 10	5 to 25	150 to 680	D3L	7.3	4.3	2.8
								-55 to 125	2.5 to 10	5 to 25	330 to 1000	D4	7.3	4.3	3.8
UPDATE TDC ^{*1}	High voltage Guaranteed at 125 °C						● ●	-55 to 125	16 to 25	90 to 100	15 to 33	B2	3.5	2.8	1.9
								-55 to 125	16 to 35	50 to 180	10 to 100	D2	7.3	4.3	1.9
								-55 to 125	16 to 25	50 to 70	68 to 150	D3L	7.3	4.3	2.8
TPC ^{*1}	Low profile	●						-55 to 105	10	45 to 100	68 to 100	D2	7.3	4.3	1.9

*1 : Some part numbers are not a recommended product

NRFND

Not recommended for new design

Series flow chart

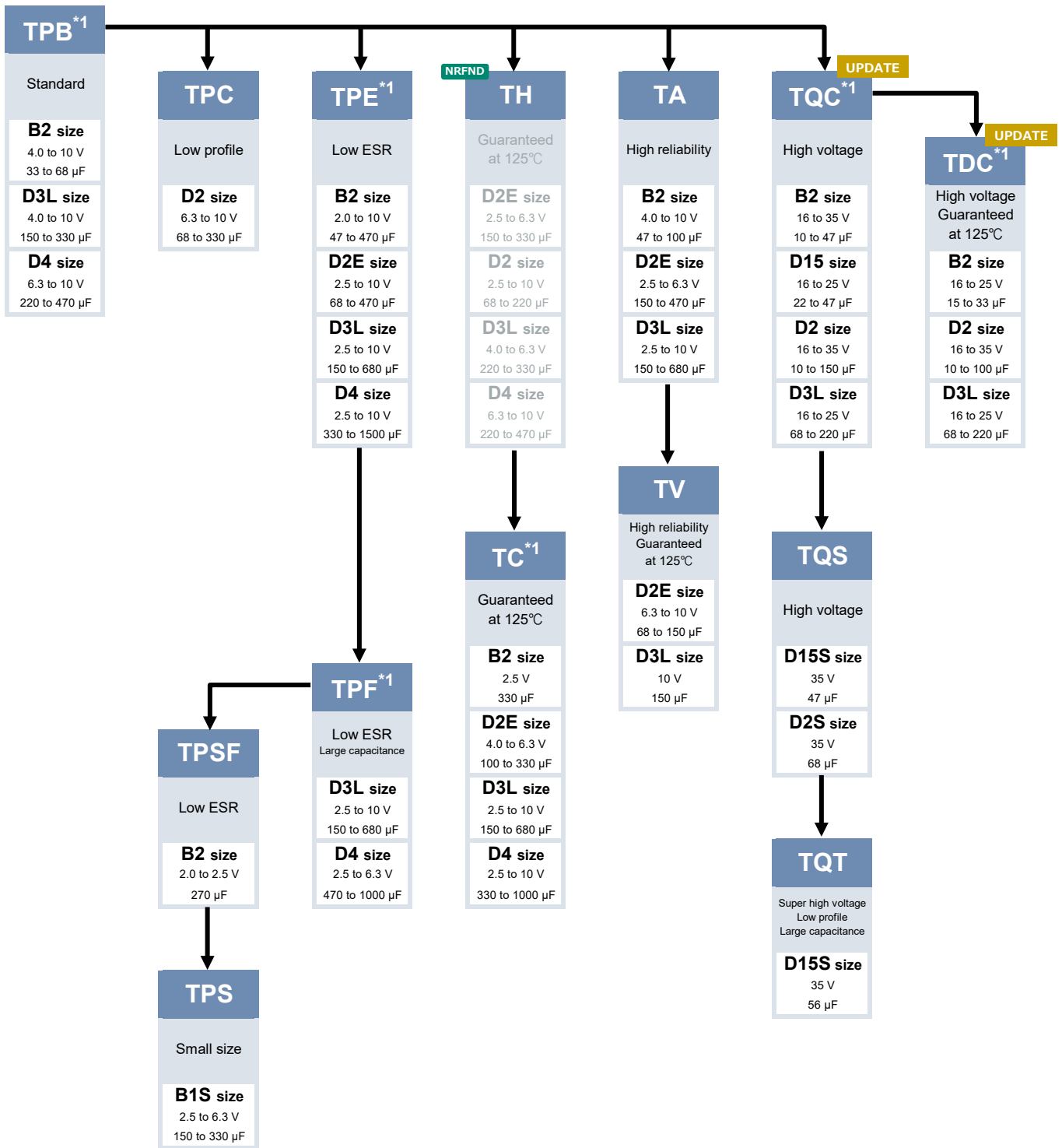

*1: Some part numbers are not a recommended product

NRFND Not recommended for new design

Voltage - Capacitance table (Vol. : 2.0 to 8.0 V / Cap. : 3.9 to 68 μ F)

Series [Size]
(ESR m Ω)

V	μ F	3.9	4.7	5.6	6.8	8.2	10	15	22	33	47	56
2.0												
2.5												
4.0												
6.3										TPB [B2] (70)	TA [B2] (70)	
8.0												

Size list LxWxH (mm)

B1	3.5x2.8x1.1	B2	3.5x2.8x1.9	D15	7.3x4.3x1.4	D2E	7.3x4.3x1.8	D3L	7.3x4.3x2.8
B1S	3.5x2.8x1.1	B2S	3.5x2.8x1.9	D15S	7.3x4.3x1.4	D2	7.3x4.3x1.9	D4	7.3x4.3x3.8
						D2S	7.3x4.3x1.9		

Voltage - Capacitance table (Vol. : 2.0 to 8.0 V / Cap. : 100 to 1500 μF)

Series [Size]
(ESR mΩ)

V	μF	68	100	120	150	220	270	330	470	680	1000	1500
2.0							TPSF [B2S] (9,6)		TPE [B2] (15,11)			
2.5						TPS [B1S] (30)	TPSF [B2S] (6)	TPS [B1S] (30)	TPE [D2E] (18,15,12,9,7)	TPE [D3L] (40,15,12)	TPE [D4] (15)	TPE [D4] (15,12)
						TPE [B2] (35,30,25,21,15)		TPE [B2] (35,18,9)	TPF [D3L] (10,7,6)	TPF [D3L] (10,9,7,6)	TPF [D4] (6,5)	
						TPE [D2E] (18,15,9)		TPE [D2E] (18,15,12,9,7)	TA [D2E] (25,15)	TPF [D4] (25)	TC [D4] (15,6,5)	
						TA [D2E] (25,15,9)		TA [D2E] (25,18,15)		TA [D3L] (25,15)		
								TC [B2] (9)		TC [D3L] (15,12,10,7,6)		
4.0		TPB [B2] (70)	TPE [B2] (70,40,35)		TPE [B2] (35)	TPS [B1S] (35,30)		TPE [D2E] (40,25,18)	TPE [D3L] (40,25,18,15,12)	TPF [D4] (35,15,10)		
			TA [B2] (70)		TPE [D2E] (18)	TPE [B2] (35)		TPF [D3L] (15,12,9)	TPF [D3L] (10)	TC [D4] (10)		
					TC [D2E] (18)	TPE [D2E] (45,25,18,15)		TC [D2E] (25,18)	TA [D3L] (25,18)			
						TA [D2E] (25,18)		TC [D3L] (12)	TC [D3L] (25,18,15,12,10)			
						TC [D2E] (25,18,15)						
6.3		TA [B2] (70)	TPE [B2] (70,45,40,35,25)	TPE [B2] (35)	TPS [B1S] (35,30)	TPE [B2] (35,25)		TPE [D2E] (25)	TPE [D4] (40,35,25,18)	TPE [D4] (25,18)		
		TPB [B2] (70)	TPE [D2E] (45,25,18)		TPE [B2] (35,25)	TPE [D2E] (40,25,18)		TPE [D3L] (25,18,15)	TPF [D4] (15,10)	TC [D4] (25,18)		
					TPE [D2E] (25,18,15)	TPE [D3L] (18)		TPF [D3L] (10,9)	TPB [D4] (35)			
					TPF [D3L] (25)	TPF [D3L] (25,15,12)		TA [D3L] (25)	TC [D4] (25,18,10)			
					TA [D2E] (25)	TA [D2E] (25,18)		TPB [D3L] (45,40)				
					TV [D2E] (25)	TC [D2E] (25,18)		TPB [D4] (40)				
					TC [D2E] (25,18,15)	TC [D3L] (12)		TC [D3L] (25,18,15,9)				
8.0			TPE [B2] (35)									

Size list LxWxH (mm)

B1	3.5x2.8x1.1	B2	3.5x2.8x1.9	D15	7.3x4.3x1.4	D2E	7.3x4.3x1.8	D3L	7.3x4.3x2.8
B1S	3.5x2.8x1.1	B2S	3.5x2.8x1.9	D15S	7.3x4.3x1.4	D2	7.3x4.3x1.9	D4	7.3x4.3x3.8
						D2S	7.3x4.3x1.9		

Voltage - Capacitance table (Vol. : 10 to 63 V / Cap. : 3.9 to 68 μF)

Series [Size]
(ESR mΩ)

V	μF	3.9	4.7	5.6	6.8	8.2	10	15	22	33	47	56
10										TPB [B2] (70)	TPE [B2] (35)	
											TA [B2] (70)	
											TPB [B2] (70)	
16										TQC [B2] (90)	TQC [B2] (90)	
										TDC [B2] (90)	TQC [D15] (55)	
											TQC [D2] (55,70)	
											TDC [D2] (55,70)	
20									TQC [B2] (90)	TQC [D2] (60)	TQC [D15] (55)	
									TQC [D2] (90)	TQC [B2] (100)	TQC [D2] (55)	
									TDC [B2] (90)	TDC [D2] (60)	TDC [D2] (55)	
25								TQC [B2] (100)	TQC [B2] (100)	TQC [D2] (60)		
								TQC [D2] (90)	TQC [D2] (60)	TDC [D2] (60)		
								TDC [B2] (100)	TDC [D2] (60)			
								TDC [D2] (90)				
35							TQC [B2] (200,150)	TQC [D2] (150)	TQC [D2] (150)		TQS [D15S] (100)	TQT [D15S] (100)
							TQC [D2] (120,180)	TDC [D2] (150)	TDC [D2] (150)			
							TDC [D2] (180)					

Size list LxWxH (mm)

B1	3.5x2.8x1.1	B2	3.5x2.8x1.9	D15	7.3x4.3x1.4	D2E	7.3x4.3x1.8	D3L	7.3x4.3x2.8
B1S	3.5x2.8x1.1	B2S	3.5x2.8x1.9	D15S	7.3x4.3x1.4	D2	7.3x4.3x1.9	D4	7.3x4.3x3.8
						D2S	7.3x4.3x1.9		

Voltage - Capacitance table (Vol. : 10 to 63 V / Cap. : 100 to 1500 μ F)

Series [Size]
(ESR m Ω)

V	μ F	68	100	120	150	220	270	330	470	680	1000	1500
10		TV [D2E] (25)	TPC [D2] (55,50,45)		TPE [D3L] (25)	TPE [D3L] (25,18)		TPE [D4] (25)				
		TPC [D2] (100,60,45)			TPF [D3L] (15)	TA [D3L] (25)		TPB [D4] (40)				
					TA [D3L] (25)	TPB [D3L] (40)		TC [D4] (25)				
					TV [D3L] (25)	TPB [D4] (40)						
					TPB [D3L] (55,40)	TC [D3L] (25,18)						
					TC [D3L] (15)							
16		TQC [D2] (50)	TQC [D2] (50)		TQC [D2] (50)	TQC [D3L] (50)						
		TDC [D2] (50)	TDC [D2] (50)		TQC [D3L] (50)							
					TDC [D3L] (50)							
20			TQC [D2] (100)									
			TQC [D3L] (55)									
			TDC [D3L] (55)									
25		TQC [D3L] (70)	TQC [D3L] (60)									
		TDC [D3L] (70)										
35		TQS [D2S] (100)										

Size list LxWxH (mm)

B1	3.5x2.8x1.1	B2	3.5x2.8x1.9	D15	7.3x4.3x1.4	D2E	7.3x4.3x1.8	D3L	7.3x4.3x2.8
B1S	3.5x2.8x1.1	B2S	3.5x2.8x1.9	D15S	7.3x4.3x1.4	D2	7.3x4.3x1.9	D4	7.3x4.3x3.8
						D2S	7.3x4.3x1.9		

Explanation of part numbers

◇ Part number system

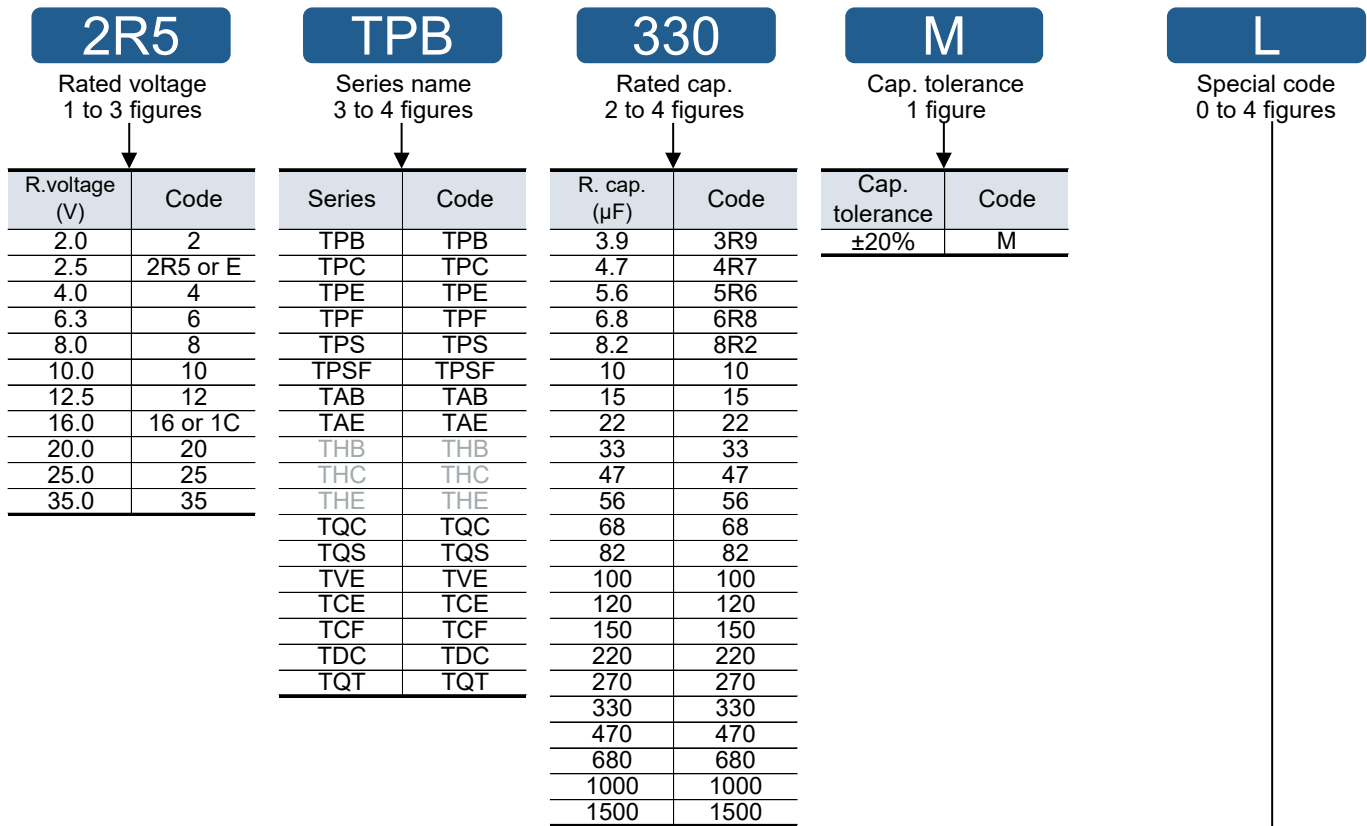

R.voltage (V)	Code
2.0	2
2.5	2R5 or E
4.0	4
6.3	6
8.0	8
10.0	10
12.5	12
16.0	16 or 1C
20.0	20
25.0	25
35.0	35

Series	Code
TPB	TPB
TPC	TPC
TPE	TPE
TPF	TPF
TPS	TPS
TPSF	TPSF
TAB	TAB
TAE	TAE
THB	THB
THC	THC
THE	THE
TQC	TQC
TQS	TQS
TVE	TVE
TCE	TCE
TCF	TCF
TDC	TDC
TQT	TQT

R. cap. (μF)	Code
3.9	3R9
4.7	4R7
5.6	5R6
6.8	6R8
8.2	8R2
10	10
15	15
22	22
33	33
47	47
56	56
68	68
82	82
100	100
120	120
150	150
220	220
270	270
330	330
470	470
680	680
1000	1000
1500	1500

Cap. tolerance	Code
±20%	M

Standard		Code
TPE series		
B2	ESR 35 mΩ max.	ZB
	ESR 25 mΩ max.	PB
	ESR 21 mΩ max.	LB
	ESR 15 mΩ max.	FB
	ESR 15 mΩ / 300 kHz max.	FGB
	ESR 35 mΩ max. 85°C	AZB
	ESR 25 mΩ max. 85°C	APB
	ESR 15 mΩ max. 85°C	AFB
	ESR 13 mΩ / 300 kHz max. 85°C	ADGB
	ESR 11 mΩ / 300 kHz max. 85°C	AJGB
D2E	ESR 25 mΩ max. 85°C	AP
D3L	ESR 25 mΩ max.	L
	ESR 18 mΩ max.	IL
	ESR 15 mΩ max.	FL
	ESR 12 mΩ max.	CL
	ESR 10 mΩ max.	AL
	ESR 25 mΩ max. 85°C	AL
	ESR 9 mΩ / 500 kHz max. 85°C	A9EL
TPB series		
D3L		L
TPC series		
85 °C		A
B1		B
TQS / TQT series		
D15S	ESR 100 mΩ / Height 1.5 mm max.	EU
D2S	ESR 100 mΩ / Height 2.0 mm max.	E2

Standard		Code
TPF series		
D3L	ESR 9 mΩ max.	9L
	ESR 7 mΩ max.	7L
	ESR 6 mΩ max.	6L
	ESR 5 mΩ max.	5L
D4	ESR 10 mΩ max.	AH
	ESR 6 mΩ max.	6H
	ESR 5 mΩ max.	5H
TQC / TDC series		
Capacitance enlarged type		YF
Capacitance enlarged type (B2 size)		YFB
Capacitance enlarged type (D12 size)		YFS
Capacitance enlarged type (D15 size)		YFT
Capacitance enlarged type (D2 size)		YFD/D2
Capacitance enlarged type (D3L size)		D3
All series		
	ESR 55 mΩ max.	G
	ESR 45 mΩ max.	V
	ESR 40 mΩ max.	W
	ESR 35 mΩ max.	Z
	ESR 18 mΩ max.	I
	ESR 15 mΩ max.	F
	ESR 12 mΩ max.	C
	ESR 9 mΩ max.	9
	ESR 7 mΩ max.	7
	ESR 6 mΩ max.	6
	ESR 5 mΩ max.	5
	ESR 35 mΩ / 300 kHz max.	ZG
	ESR 30 mΩ / 300 kHz max.	UG
	ESR 9 mΩ / 300 kHz max.	9G
	ESR 6 mΩ / 500 kHz max.	6E
	ESR 4 mΩ / 500 kHz max.	4E

TPE/TPF/THC/TPC/TQC series some part numbers : Not recommended for new design

Mounting specifications

◆ **Recommendable reflow soldering**

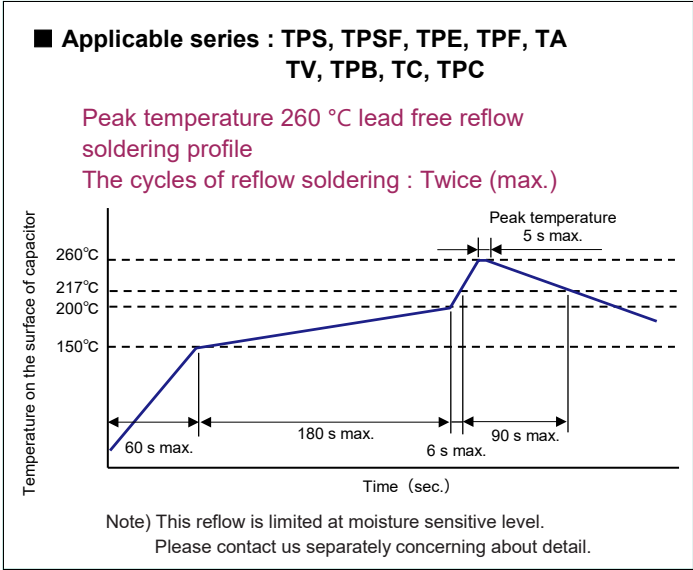
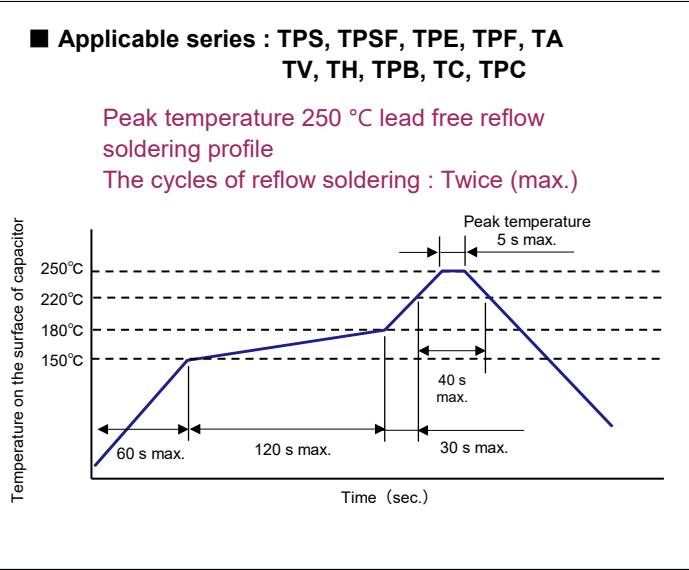

■ **Applicable series : TQC, TDC, TQS, TQT**

* Refer to the characteristics list of each series for compatible part numbers.

Reflow soldering	Condition A	Condition B	Condition C	Condition D
	IPC/J-STD-020 reflow profile		Peak temperature 250 °C lead free reflow profile	
Peak temperature (TP)	260 °C	250 °C	250 °C	
Time within -5 °C of peak temperature	30 seconds max.		-	
Soldering time (tL) above soldering temperature (TL)	TL ≥ 217 °C	150 seconds max.	90 seconds max.	60 seconds max.
	TL ≥ 200 °C	-	-	70 seconds max.
Preheat	Temperature max. (Tsmáx)	200 °C	180 °C	
	Temperature min. (Tsmín)	150 °C		
	Time (ts) from (Tsmín) to (Tsmáx)	120 seconds max.		
The cycles of reflow soldering	3 times (max.)		Twice (max.)	

● **Soldering with a soldering iron**

Tip of a soldering iron : 350 °C max (TQC / TDC / TQS / TQT series : 400 °C max.)
 Working time : 3 sec. max. (TQC / TQS / TQT series : 5 sec. max.)
 (Do not let the tip of soldering iron touch the POSCAP itself. Do not subject the POSCAP itself to excessive stress when soldering)

Land pattern

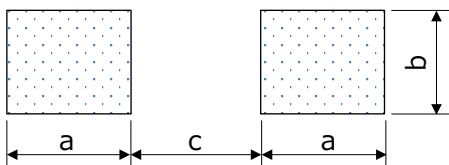

Unit : mm

Size code	a	b	c
B1, B1S, B2, B2S	1.6	2.7	1.4
D15, D2E, D2, D3L, D4	2.4	2.9	3.7
D15S	1.4 / 1.7*1	2.6	4.6
D2S	1.4	2.6	5.1

*1 : +side / -side

Packing specifications

◇ Dimension of carrier tape

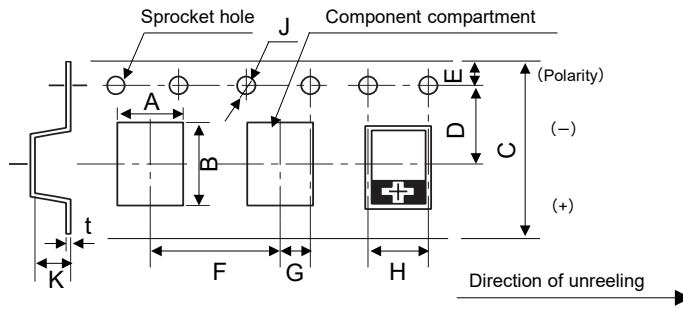

Unit : mm

Size code	A±0.2	B±0.2	C±0.3	D±0.1	E±0.1	F±0.1	G±0.1	H±0.1	J $\begin{smallmatrix} +0.1 \\ -0 \end{smallmatrix}$	K±0.1	t±0.1
B1	3.2	3.8	8.0	3.5	1.75	4.0	2.0	4.0	∅1.5	1.4	0.25
B1S	3.25	3.9	8.0	3.5	1.75	4.0	2.0	4.0	∅1.5	1.7	0.25
B2	3.3	3.8	8.0	3.5	1.75	4.0	2.0	4.0	∅1.5	2.1	0.25
B2S	3.25	4.0	8.0	3.5	1.75	4.0	2.0	4.0	∅1.5	2.1	0.25
D12	4.5	7.5	12.0	5.5	1.75	8.0	2.0	4.0	∅1.5	1.7	0.3
D15	4.5	7.5	12.0	5.5	1.75	8.0	2.0	4.0	∅1.5	2.4	0.3
D15S	4.7	7.8	12.0	5.5	1.75	8.0	2.0	4.0	∅1.5	1.7	0.3
D2E	4.5	7.5	12.0	5.5	1.75	8.0	2.0	4.0	∅1.5	2.4	0.3
D2	4.5	7.5	12.0	5.5	1.75	8.0	2.0	4.0	∅1.5	2.4	0.3
D2S	4.5	7.8	12.1	5.5	1.75	8.0	2.0	4.0	∅1.5	2.4	0.3
D3L	4.5	7.7	12.0	5.5	1.75	8.0	2.0	4.0	∅1.5	3.2	0.3
D4	4.5	7.7	12.0	5.5	1.75	8.0	2.0	4.0	∅1.5	4.2	0.3

- Dimension A and B are the measure of compartment's inside bottom.
- The (+) Polarity of the chip is placed on right side towards the unreeling direction.
- Dimension of the topcover tape.
Thickness of cover tape : 62±10 μm, Width of cover tape : 9.5±0.2 mm 5.5±0.2 mm (∅180)

D12 size : Not recommended for new design

◇ Reel dimension

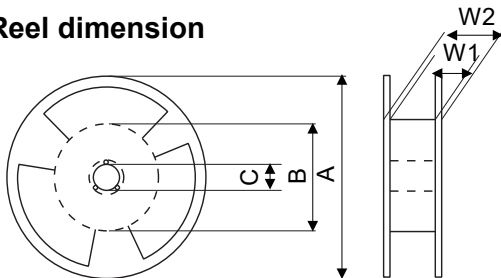

Unit : mm

A	B	C	W1	W2
∅330±2	∅80±2	∅13.0±0.2	13.5±0.5	17.5±1.0
∅180 $\begin{smallmatrix} 0 \\ -3 \end{smallmatrix}$	∅60±2	∅13.0±0.2	9.0±0.5	11.4±1.0

◇ Minimum packing quantity and weight

(∅180)

Size code	Qty. (pcs./Reel)	Typical weight (g)
B1	3000	200
B1S	2500	200
B2, B2S	2000	200

(∅330)

Size code	Qty. (pcs./Reel)	Typical weight (g)
D12	4500	1200
D15	3000	1000
D15S	4000	1000
D2E, D2, D2S	3000	1000
D3L	2500	1100
D4	2000	1200

※ Small order quantity (500 pcs/reel) is available with TPE, TPF and TQC series.
Please contact our sales representative if you prefer it.

D12 size : Not recommended for new design

◇ Dimension of packing case

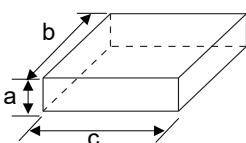

Unit : mm

Reel size	∅180	∅330
a	90	120
b	240	360
c	240	360

◇ Units per packing case

Size code	Pieces/case	Size code	Pieces/case
B1	15000	D12	22500
B1S	12500	D15	15000
B2, B2S	10000	D15S	20000
		D2E, D2, D2S	15000
		D3L	12500
		D4	10000

D12 size

: Not recommended for new design

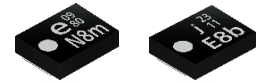

Conductive Polymer Tantalum Solid Capacitors

Surface Mount Type

TPS series

Features

- 105 °C 2000 h
- Small size, Low profile (L 3.5 × W 2.8 × H 1.2 mm max.)
- RoHS compliance, Halogen free

Specifications

Size code	B1S	
Category temp. range	-55 °C to +105 °C	
Rated voltage range	2.5 V to 6.3 V	
Category voltage range	2.5 V to 6.3 V	
Rated capacitance range	150 μF to 330 μF	
Capacitance tolerance	±20 % (120 Hz / +20 °C)	
Leakage current	Please see the attached characteristics list	
Dissipation factor(tan δ)	Please see the attached characteristics list	
Surge voltage (V)	Rated voltage × 1.15	
Endurance	+105 °C 2000 h rated voltage applied	
	Capacitance change	Within ±20 % of the initial value
	Dissipation factor(tan δ)	≤ 1.5 times of the initial limit
	Leakage current	Within the initial limit
Damp heat (Steady State)	+60 °C, 90 % to 95 % RH, 500 h, No-applied voltage	
	Capacitance change	Within +40 %, -20 % of the initial value
	Dissipation factor(tan δ)	≤ 1.5 times of the initial limit
	Leakage current	≤ 3 times of the initial limit

Marking

R.voltage code	Unit : V	R.capacitance code	Unit : μF
e	2.5	E8	150
g	4.0	J8	220
j	6.3	N8	330

Dimensions (not to scale)

Size code	L±0.2	W±0.2	H±0.1	S±0.3	W1±0.1
B1S	3.5	2.8	1.1	0.8	2.2

Unit : mm

* Externals of figure are the reference.

Characteristics list

Rated voltage (V)	Rated temperature (°C)	Category voltage (V)	Category temperature (°C)	Rated capacitance (μF)	Case size (mm)			Size code	Specifications				Standard		Floor life level	
					L	W	H		Ripple current ¹ (mA rms)	ESR ² (mΩ max.)	tan δ ³	LC ⁴ (μA)	Part number	Min. packaging q'ty (pcs)	Reflow temp ≤260°C	Reflow temp ≤250°C
2.5	105	2.5	105	220	3.5	2.8	1.1	B1S	1400	30	0.10	55.0	ETPS220MUD	2500	3	3
	105	2.5	105	330	3.5	2.8	1.1		1400	30	0.10	82.5	ETPS330MUD	2500		
4.0	105	4.0	105	220	3.5	2.8	1.1		1400	30	0.10	88.0	4TPS220MUD	2500		
	105	6.3	105	150	3.5	2.8	1.1		1400	30	0.10	94.5	6TPS150MUD	2500		
6.3	105	6.3	105		3.5	2.8	1.1		1250	35	0.10	94.5	6TPS150MZD	2500		

*1: Ripple current (100 kHz / +45 °C)

*2: ESR (100 kHz / +20 °C)

*3: tan δ (120 Hz / +20 °C)

*4: After 5 minutes

◆ Please refer to each page in this catalog for "Reflow conditions", "Taping specifications" and "Floor life level".

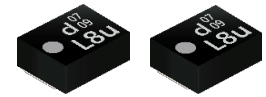

Conductive Polymer Tantalum Solid Capacitors

Surface Mount Type

TPSF series

Features

- Super low ESR (6 mΩ max.)
- Super low ESL (0.7 nH max.)
- Face down terminal type
- RoHS compliance, Halogen free

Specifications

Size code	B2S	
Category temp. range	-55 °C to +105 °C	
Rated voltage range	2.0 V to 2.5 V	
Category voltage range	2.0 V to 2.5 V	
Rated capacitance range	270 μF	
Capacitance tolerance	±20 % (120 Hz / +20 °C)	
Leakage current	Please see the attached characteristics list	
Dissipation factor(tan δ)	Please see the attached characteristics list	
Surge voltage (V)	Rated voltage × 1.15	
Endurance	+105 °C 1000 h rated voltage applied	
	Capacitance change	Within ±20 % of the initial value
	Dissipation factor(tan δ)	≤ 1.5 times of the initial limit
	Leakage current	Within the initial limit
Damp heat (Steady State)	+60 °C, 90 % to 95 % RH, 500 h, No-applied voltage	
	Capacitance change	Within +40 %, -20 % of the initial value
	Dissipation factor(tan δ)	≤ 1.5 times of the initial limit
	Leakage current	≤ 3 times of the initial limit

Marking

Rated voltage code

Polarity marking (+)

Rated capacitance code

Lot. No.

R.voltage code	Unit : V
d	2.0
e	2.5

R.capacitance code	Unit : μF
L8	270

Dimensions (not to scale)

	Unit : mm				
Size code	L±0.2	W±0.2	H±0.1	S±0.3	W1±0.1
B2S	3.5	2.8	1.9	0.8	2.2

* Externals of figure are the reference.

Characteristics list

Rated voltage (V)	Rated temperature (°C)	Category voltage (V)	Category temperature (°C)	Rated capacitance (μF)	Case size (mm)			Size code	Specifications				Standard		Floor life level	
					L	W	H		Ripple ^{*1} current (mA rms)	ESR ^{*2} (mΩ max.)	tan δ ^{*3}	LC ^{*4} (μA)	Part number	Min. packaging q'ty (pcs)	Reflow temp ≤260°C	Reflow temp ≤250°C
2.0	105	2.0	105	270	3.5	2.8	1.9	B2S	3200	6/500 kHz	0.08	108.0	2TPSF270M6E	2000	5	5
	105	2.0	105		3.5	2.8	1.9		2400	9/300 kHz	0.08	108.0	2TPSF270M9G	2000	3	3
2.5	105	2.5	105		3.5	2.8	1.9		3200	6/500 kHz	0.08	135.0	ETPSF270M6E	2000		

*1: Ripple current (100 kHz / +45 °C) *2: ESR (100 kHz / +20 °C) *3: tan δ (120 Hz / +20 °C) *4: After 5 minutes

◆ Please refer to each page in this catalog for "Reflow conditions", "Taping specifications" and "Floor life level".



Conductive Polymer Tantalum Solid Capacitors

Surface Mount Type

TPE series B size

Features

- Small size (L 3.5 × W 2.8 × H 1.9 mm)
- Low ESR (15 mΩ max.)
- RoHS compliance, Halogen free

Specifications

Size code	B2	
Category temp. range	-55 °C to +105 °C	
Rated voltage range	2.0 V to 10 V	
Category voltage range	1.8 V to 8 V	
Rated capacitance range	47 μF to 470 μF	
Capacitance tolerance	±20 % (120 Hz / +20 °C)	
Leakage current	Please see the attached characteristics list	
Dissipation factor(tan δ)	Please see the attached characteristics list	
Surge voltage (V)	Rated voltage × 1.15	
Endurance	+105 °C 1000 h rated voltage applied	
	Rated temp, +85 °C Products : +85 °C 1000 h, rated voltage applied	
	Capacitance change	Within ±20 % of the initial value
	Dissipation factor(tan δ)	≤ 1.5 times of the initial limit
Damp heat (Steady State)	+60 °C, 90 % to 95 % RH, 500 h, No-applied voltage	
	Capacitance change	Within +50 %, -20 % of the initial value (2R5TPE220MAZB (MAPB, MAFB), 2R5TPE330MAZB, 2TPE470MAJGB (MAFB))
	Dissipation factor(tan δ)	≤ 1.5 times of the initial limit
	Leakage current	≤ 3 times of the initial limit

Marking

Rated capacitance code

Polarity marking (+)

Rated voltage code

Lot No.

R. voltage code		Unit : V	
d	2.0	g	4.0
e	2.5	j	6.3
		k	8.0
		A	10

R. capacitance code		Unit : μF	
S7	47	E8	150
A8	100	J8	220
C8	120	N8	330
		S8	470

Dimensions (not to scale)

Size code	L±0.2	W±0.2	H±0.1	S±0.2	W1±0.1
B2	3.5	2.8	1.9	0.8	2.2

Unit : mm

* Externals of figure are the reference.

Characteristics list

Rated voltage (V)	Rated temperature (°C)	Category voltage (V)	Category temperature (°C)	Rated capacitance (μF)	Case size (mm)			Size code	Specifications				Standard		Floor life level		
					L	W	H		Ripple current (mA rms)	ESR*2 (mΩ max.)	tan δ*3	LC*4 (μA)	Part number	Min. packaging q'ty (pcs)	Reflow temp ≤260°C	Reflow temp ≤250°C	
2.0	85	1.8	105	470	3.5	2.8	1.9	B2	2300	15	0.10	188.0	2TPE470MAFB	2000	3	3	
	85	1.8	105		3.5	2.8	1.9		2300	11/300kHz	0.08	188.0	2TPE470MAJGB	2000			
2.5	85	2.0	105	220	3.5	2.8	1.9		2000	15	0.08	110.0	2R5TPE220MAFB	2000			
	105	2.5	105		3.5	2.8	1.9		1800	15/300kHz	0.08	110.0	2R5TPE220MFGB	2000			
	105	2.5	105		3.5	2.8	1.9		1700	21	0.08	55.0	2R5TPE220MLB	2000			
	85	2.0	105		3.5	2.8	1.9		1600	25	0.08	55.0	2R5TPE220MAPB	2000			
	105	2.5	105		3.5	2.8	1.9		1400	35	0.08	55.0	2R5TPE220MZB	2000			
	85	2.0	105		3.5	2.8	1.9		1400	35	0.08	55.0	2R5TPE220MAZB	2000			
	105	2.5	105		3.5	2.8	1.9		1400	30	0.08	55.0	2R5TPE220MUB	2000			
	85	2.0	105		330	3.5	2.8		1.9	1400	35	0.08	82.5	2R5TPE330MAZB			2000
	85	2.0	105			3.5	2.8		1.9	3200	9/300kHz	0.08	165.0	ETPE330MA9GB			2000
	105	2.5	105			3.5	2.8		1.9	3200	9/300kHz	0.08	165.0	ETPE330M9GB			2000
105	2.5	105	3.5	2.8		1.9	2700		15	0.08	165.0	ETPE330MFB	2000				
4.0	105	4.0	105	100	3.5	2.8	1.9		2450	18	0.08	165.0	ETPE330MIB	2000			
	105	4.0	105		3.5	2.8	1.9		1400	35	0.08	40.0	4TPE100MZB	2000			
	105	4.0	105		3.5	2.8	1.9		950	70	0.08	40.0	4TPE100MBB	2000			
	85	3.2	105	150	3.5	2.8	1.9		1300	40	0.08	40.0	4TPE100MWB	2000			
	85	3.2	105	220	3.5	2.8	1.9		1400	35	0.08	60.0	4TPE150MAZB	2000			
	NRFND	105	4.0		105	3.5	2.8		1.9	1400	35	0.08	88.0	4TPE220MAZB			2000
	NRFND	105	4.0		105	3.5	2.8		1.9	1350	35	0.10	88.0	4TPE220MZB			2000
	NRFND	105	4.0		105	3.5	2.8	1.9	1150	45	0.10	88.0	4TPE220MVB	2000			
	6.3	105	6.3	105	100	3.5	2.8	1.9	950	70	0.10	88.0	4TPE220MBB	2000			
		85	5.0	105		3.5	2.8	1.9	1600	25	0.08	63.0	6TPE100MPB	2000			
105		6.3	105	3.5		2.8	1.9	1400	35	0.08	63.0	6TPE100MAZB	2000				
105		6.3	105	3.5		2.8	1.9	1400	35	0.08	63.0	6TPE100MZB	2000				
105		6.3	105	3.5		2.8	1.9	950	70	0.08	63.0	6TPE100MBB	2000				
105		6.3	105	3.5		2.8	1.9	1300	40	0.08	63.0	6TPE100MWB	2000				
105		6.3	105	3.5		2.8	1.9	1200	45	0.08	63.0	6TPE100MVB	2000				
85		5.0	105	120	3.5	2.8	1.9	1400	35	0.08	75.6	6TPE120MAZB	2000				
85		5.0	105	150	3.5	2.8	1.9	1600	25	0.08	94.5	6TPE150MAPB	2000				
85		5.0	105		3.5	2.8	1.9	1400	35	0.08	94.5	6TPE150MAZB	2000				
8.0		85	5.0	105	220	3.5	2.8	1.9	1400	35	0.10	138.6	6TPE220MAZB	2000			
		85	5.0	105		3.5	2.8	1.9	1600	25	0.10	138.6	6TPE220MAPB	2000			
		NRFND	105	6.3		105	3.5	2.8	1.9	1150	45	0.10	138.6	6TPE220MVB	2000		
		NRFND	105	6.3		105	3.5	2.8	1.9	950	70	0.10	138.6	6TPE220MBB	2000		
	NRFND	105	6.3	105		3.5	2.8	1.9	1350	35	0.10	138.6	6TPE220MZB	2000			
	8.0	85	6.3	105		100	3.5	2.8	1.9	1400	35	0.08	80.0	8TPE100MAZB	2000		
10	85	8.0	105	47	3.5	2.8	1.9	1400	35	0.08	47.0	10TPE47MAZB	2000				

*1: Ripple current (100 kHz / +45 °C)

NRFND Not recommended for new design

*2: ESR (100 kHz / +20 °C)

*3: tan δ (120 Hz / +20 °C)

*4: After 5 minutes

◆ Please refer to each page in this catalog for "Reflow conditions", "Taping specifications" and "Floor life level".

◆ Small order quantity (500 pcs/reel) is available with TPE series. Please contact our sales representative if you prefer it.

Conductive Polymer Tantalum
Solid Capacitors
Surface Mount Type
TPE series D size

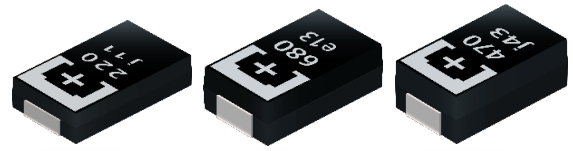

Features

- Low ESR (7 mΩ max.)
- Large capacitance (1500 μF max.)
- RoHS compliance, Halogen free

Specifications

Size code	D2E	D3L	D4
Category temp. range	-55 °C to +105 °C		
Rated voltage range	2.5 V to 10 V		
Category voltage range	2.5 V to 10 V		
Rated capacitance range	68 μF to 470 μF	150 μF to 680 μF	330 μF to 1500 μF
Capacitance tolerance	±20 % (120 Hz / +20 °C)		
Leakage current	Please see the attached characteristics list		
Dissipation factor(tan δ)	Please see the attached characteristics list		
Surge voltage (V)	Rated voltage × 1.15		
Endurance	+105 °C 2000 h rated voltage applied Rated temp, +85 °C Products : +85 °C 1000 h, rated voltage applied (6TPE330MAP : +85 °C 2000 h, rated voltage applied)		
	Capacitance change	Within ±20 % of the initial value	
	Dissipation factor(tan δ)	≤ 1.5 times of the initial limit	
	Leakage current	Within the initial limit	
Damp heat (Steady State)	+60 °C, 90 % to 95 % RH, 500 h, No-applied voltage		
	Capacitance change	Within +50 %, -20 % of the initial value (2R5TPE220M (I, F, 9), 2R5TPE330M (I, F, C, 9, 7), 2R5TPE470M (I, F, C, 9, 7), 2R5TPE1000MF, 2R5TPE1500M (F, C))	
	Dissipation factor(tan δ)	≤ 1.5 times of the initial limit	
	Leakage current	≤ 3 times of the initial limit	

Marking

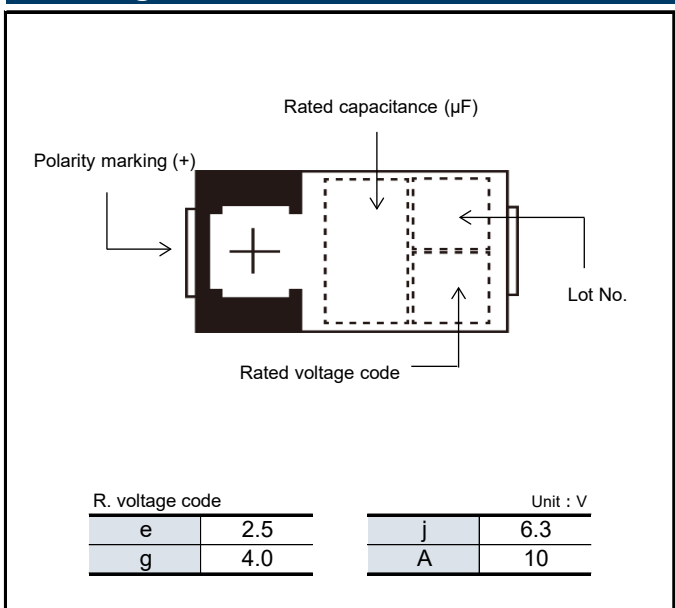

Dimensions (not to scale)

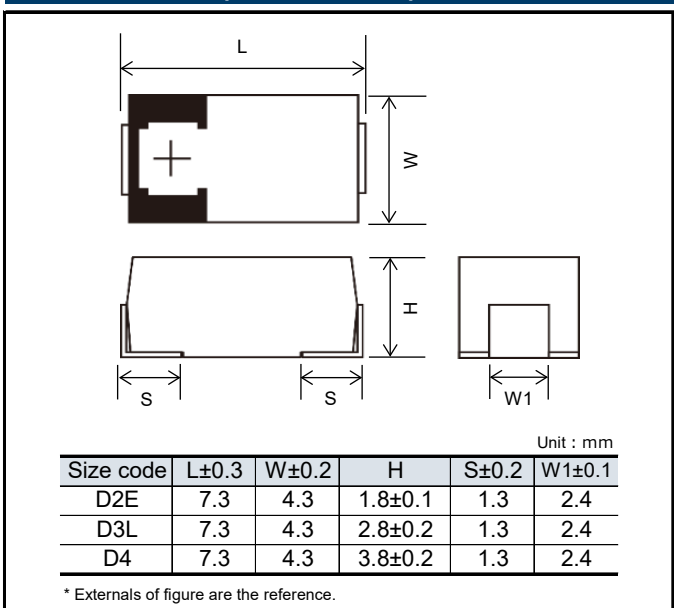

Characteristics list

Rated voltage (V)	Rated temperature (°C)	Category voltage (V)	Category temperature (°C)	Rated capacitance (μF)	Case size (mm)			Size code	Specifications				Standard		Floor life level		
					L	W	H		Ripple ^{*1} current (mA rms)	ESR ^{*2} (mΩ max.)	tan δ ^{*3}	LC ^{*4} (μA)	Part number	Min. packaging q'ty (pcs)	Reflow temp ≤260°C	Reflow temp ≤250°C	
2.5	105	2.5	105	220	7.3	4.3	1.8	D2E	3900	9	0.10	55.0	2R5TPE220M9	3000	3		
					7.3	4.3	1.8		3100	15	0.10	55.0	2R5TPE220MF	3000			
	7.3	4.3	1.8		2800	18	0.10		55.0	2R5TPE220MI	3000						
	NRFND	105	2.5		105	7.3	4.3		1.8	2400	25	0.10	55.0	2R5TPE220M			3000
	105	2.5	105		7.3	4.3	1.8		4400	7	0.10	82.5	2R5TPE330M7	3000			
	105	2.5	105		7.3	4.3	1.8		3900	9	0.10	82.5	2R5TPE330M9	3000			
	105	2.5	105	7.3	4.3	1.8	3500		12	0.10	82.5	2R5TPE330MC	3000				
	105	2.5	105	7.3	4.3	1.8	3100		15	0.10	82.5	2R5TPE330MF	3000				
	105	2.5	105	7.3	4.3	1.8	2800		18	0.10	82.5	2R5TPE330MI	3000				
	NRFND	105	2.5	105	7.3	4.3	1.8		2400	25	0.10	82.5	2R5TPE330M	3000			
	105	2.5	105	7.3	4.3	1.8	4400		7	0.10	117.5	2R5TPE470M7	3000				
	105	2.5	105	7.3	4.3	1.8	3900		9	0.10	117.5	2R5TPE470M9	3000				
	105	2.5	105	7.3	4.3	1.8	3500		12	0.10	117.5	2R5TPE470MC	3000				
	105	2.5	105	7.3	4.3	1.8	3100		15	0.10	117.5	2R5TPE470MF	3000				
	105	2.5	105	7.3	4.3	1.8	2800		18	0.10	117.5	2R5TPE470MI	3000				
	105	2.5	105	7.3	4.3	2.8	3500		12	0.10	170.0	2R5TPE680MCL	2500				
	105	2.5	105	7.3	4.3	2.8	3100		15	0.10	170.0	2R5TPE680MFL	2500				
	105	2.5	105	7.3	4.3	2.8	1850		40	0.10	170.0	2R5TPE680MWL	2500				
	105	2.5	105	7.3	4.3	3.8	3900		15	0.15	250.0	2R5TPE1000MF	2000				
	105	2.5	105	7.3	4.3	3.8	4400		12	0.15	375.0	2R5TPE1500MC	2000				
105	2.5	105	7.3	4.3	3.8	3900	15	0.15	375.0	2R5TPE1500MF	2000						
4.0	105	4.0	105	150	7.3	4.3	1.8	D2E	2800	18	0.10	60.0	4TPE150MI	3000	2a		
					7.3	4.3	1.8		3100	15	0.10	88.0	4TPE220MF	3000			
	7.3	4.3	1.8		2800	18	0.10		88.0	4TPE220MI	3000						
	7.3	4.3	1.8		2400	25	0.10		88.0	4TPE220M	3000						
	7.3	4.3	1.8		1750	45	0.10		88.0	4TPE220MV	3000						
	7.3	4.3	1.8		2800	18	0.10		132.0	4TPE330MI	3000						
	7.3	4.3	1.8	2400	25	0.10	132.0		4TPE330M	3000							
	7.3	4.3	1.8	1850	40	0.10	132.0		4TPE330MW	3000							
	7.3	4.3	2.8	3500	12	0.10	188.0		4TPE470MCL	2500							
	7.3	4.3	2.8	3100	15	0.10	188.0		4TPE470MFL	2500							
	7.3	4.3	2.8	2800	18	0.10	188.0		4TPE470MIL	2500							
	7.3	4.3	2.8	2400	25	0.10	188.0		4TPE470ML	2500							
	7.3	4.3	2.8	1850	40	0.10	188.0		4TPE470MWL	2500							
	105	4.0	105	7.3	4.3	2.8	2800		18	0.10	63.0	6TPE100MI	3000				
	105	4.0	105	7.3	4.3	1.8	2400		25	0.10	63.0	6TPE100M	3000				
	105	4.0	105	7.3	4.3	1.8	1850		40	0.10	63.0	6TPE100MW	3000				
	105	4.0	105	7.3	4.3	1.8	3100		15	0.10	94.5	6TPE150MF	3000				
	105	4.0	105	7.3	4.3	1.8	2800		18	0.10	94.5	6TPE150MI	3000				
105	4.0	105	7.3	4.3	1.8	2400	25	0.10	94.5	6TPE150M	3000						
105	4.0	105	7.3	4.3	1.8	2800	18	0.10	138.6	6TPE220MI	3000						
105	4.0	105	7.3	4.3	1.8	2400	25	0.10	138.6	6TPE220M	3000						
85	5.0	105	7.3	4.3	1.8	2400	25	0.10	138.6	6TPE220MAP	3000						
105	6.3	105	7.3	4.3	1.8	1850	40	0.10	138.6	6TPE220MW	3000						
105	6.3	105	7.3	4.3	2.8	D3L	2800	18	0.10	138.6	6TPE220MIL	2500					
6.3	85	5.0	105	100	7.3	4.3	1.8	D2E	2400	25	0.10	207.9	6TPE330MAP	3000	3		
					7.3	4.3	2.8		3900	9/500kHz	0.10	207.9	6TPE330MA9EL	2500			
	7.3	4.3	2.8		3100	15	0.10		207.9	6TPE330MFL	2500						
	7.3	4.3	2.8		2800	18	0.10		207.9	6TPE330MIL	2500						
	7.3	4.3	2.8		2400	25	0.10		207.9	6TPE330ML	2500						
	NRFND	85	5.0		105	7.3	4.3		3.8	D4	4400	10	0.10	207.9			6TPE330MAA
	105	6.3	105	7.3	4.3	3.8	3500		18	0.15	296.1	6TPE470MI	2000				
	105	6.3	105	7.3	4.3	3.8	3000		25	0.15	296.1	6TPE470M	2000				
	105	6.3	105	7.3	4.3	3.8	2500		35	0.15	296.1	6TPE470MZ	2000				
	105	6.3	105	7.3	4.3	3.8	2350		40	0.15	296.1	6TPE470MW	2000				
	105	6.3	105	7.3	4.3	3.8	3500		18	0.15	428.4	6TPE680MI	2000				
	105	6.3	105	7.3	4.3	3.8	3000		25	0.15	428.4	6TPE680M	2000				
10	NRFND	105	10	68	7.3	4.3	1.8	D2E	2400	25	0.10	68.0	10TPE68M	3000	3		
					7.3	4.3	1.8		1850	40	0.10	68.0	10TPE68MW	3000			
	105	10	105	7.3	4.3	2.8	2400		25	0.10	150.0	10TPE150MPL	2500				
	105	10	105	7.3	4.3	2.8	D3L		2800	18	0.10	220.0	10TPE220MIL	2500			
	105	10	105	7.3	4.3	2.8	2400		25	0.10	220.0	10TPE220ML	2500				
	105	10	105	7.3	4.3	3.8	D4		3000	25	0.10	330.0	10TPE330M	2000			

*1: Ripple current (100 kHz / +45 °C) *2: ESR (100 kHz / +20 °C) *3: tan δ (120 Hz / +20 °C) *4: After 5 minutes

◆ Please refer to each page in this catalog for "Reflow conditions", "Taping specifications" and "Floor life level".

◆ Small order quantity (500 pcs/reel) is available with TPE series. Please contact our sales representative if you prefer it.

NRFND Not recommended for new design

Conductive Polymer Tantalum Solid Capacitors Surface Mount Type TPF series

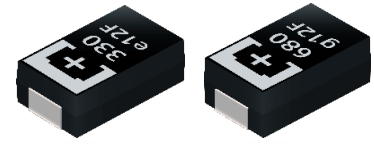

Features

- Super low ESR (5 mΩ max.)
- Large capacitance (1000 μF max.)
- RoHS compliance, Halogen free

Specifications

Size code	D3L	D4
Category temp. range	-55 °C to +105 °C	
Rated voltage range	2.5 V to 10 V	2.5 V to 6.3 V
Category voltage range	2.5 V to 10 V	2.5 V to 6.3 V
Rated capacitance range	150 μF to 680 μF	470 μF to 1000 μF
Capacitance tolerance	±20 % (120 Hz / +20 °C)	
Leakage current	Please see the attached characteristics list	
Dissipation factor(tan δ)	Please see the attached characteristics list	
Surge voltage (V)	Rated voltage × 1.15	
Endurance	+105 °C 2000 h rated voltage applied	
	Capacitance change	Within ±20 % of the initial value
	Dissipation factor(tan δ)	≤ 1.5 times of the initial limit
	Leakage current	Within the initial limit
Damp heat (Steady State)	+60 °C, 90 % to 95 % RH, 500 h, No-applied voltage	
	Capacitance change	Within +50 %, -20 % of the initial value (2TPF220M6, 2TPF330M6, ETPF1000M6H (5H))
	Dissipation factor(tan δ)	≤ 1.5 times of the initial limit (Except for above model)
	Leakage current	≤ 3 times of the initial limit

Marking

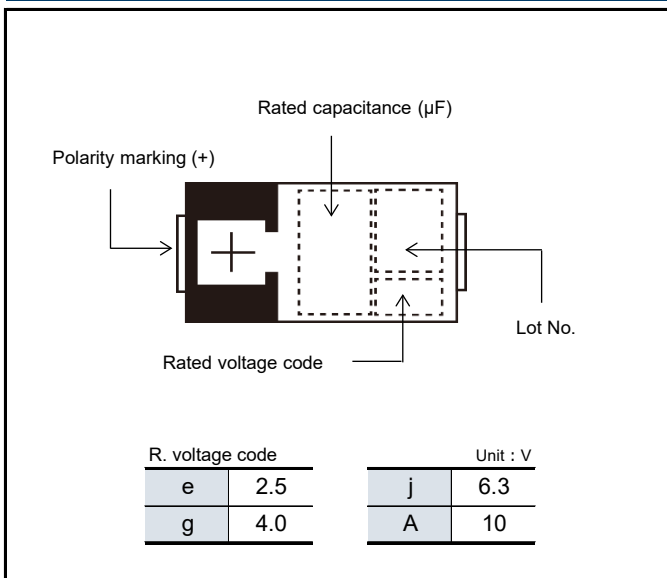

Dimensions (not to scale)

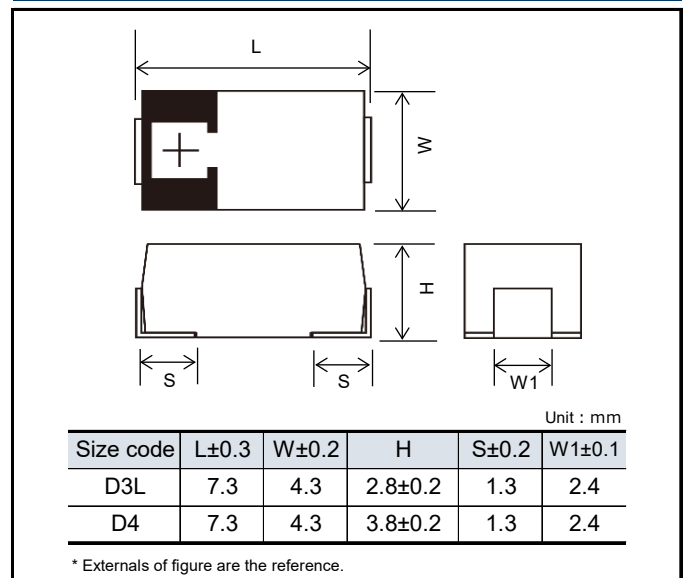

Characteristics list

Rated voltage (V)	Rated temperature (°C)	Category voltage (V)	Category temperature (°C)	Rated capacitance (µF)	Case size (mm)			Size code	Specifications				Standard		Floor life level	
					L	W	H		Ripple current (mA rms)	ESR* ² (mΩ max.)	tan δ* ³	LC* ⁴ (µA)	Part number	Min. packaging qty (pcs)	Reflow temp ≤260°C	Reflow temp ≤250°C
2.5	105	2.5	105	470	7.3	4.3	2.8	D3L	4400	6	0.10	117.5	2R5TPF470M6L	2500	3	2a
	105	2.5	105		7.3	4.3	2.8		4400	7	0.10	117.5	2R5TPF470M7L	2500		
	105	2.5	105		7.3	4.3	2.8		4400	10	0.10	117.5	2R5TPF470ML	2500		
	NRFND 105	2.5	105		7.3	4.3	3.8	D4	6100	5	0.10	117.5	ETPF470M5H	2000		
	105	2.5	105	680	7.3	4.3	2.8	D3L	3850	9	0.10	117.5	2R5TPF470M9L	2500		
	105	2.5	105		7.3	4.3	2.8		4400	6	0.10	170.0	2R5TPF680M6L	2500		
	105	2.5	105		7.3	4.3	2.8		4400	7	0.10	170.0	2R5TPF680M7L	2500		
	NRFND 105	2.5	105		7.3	4.3	2.8	D4	6100	10	0.10	170.0	2R5TPF680ML	2500		
	105	2.5	105	1000	7.3	4.3	3.8	D4	6100	5	0.10	170.0	ETPF680MPH	2000		
	105	2.5	105		7.3	4.3	3.8		2700	25	0.10	170.0	ETPF680MPH	2000		
	105	2.5	105		7.3	4.3	3.8		6100	5	0.10	250.0	ETPF1000M5H	2000		
	105	2.5	105		7.3	4.3	3.8	5600	6	0.10	250.0	ETPF1000M6H	2000			
4.0	105	4.0	105	330	7.3	4.3	2.8	D3L	3900	9	0.10	132.0	4TPF330M9L	2500		
	105	4.0	105		7.3	4.3	2.8		4000	12	0.10	132.0	4TPF330ML	2500		
	105	4.0	105		7.3	4.3	2.8		3550	15	0.10	132.0	4TPF330MFL	2500		
	105	4.0	105	680	7.3	4.3	2.8	D4	4400	10	0.10	188.0	4TPF470ML	2500		
	105	4.0	105		7.3	4.3	3.8		4400	10	0.10	272.0	4TPF680MAH	2000		
	105	4.0	105		7.3	4.3	3.8		3550	15	0.10	272.0	4TPF680MFH	2000		
6.3	105	6.3	105	150	7.3	4.3	2.8	D3L	2750	25	0.10	94.5	6TPF150MPL	2500		
	NRFND 105	6.3	105		7.3	4.3	2.8		5550	6	0.10	138.6	6TPF220M6L	2500		
	NRFND 105	6.3	105	220	7.3	4.3	2.8		D3L	4600	9	0.10	138.6	6TPF220M9L	2500	
	105	6.3	105		7.3	4.3	2.8			4000	12	0.10	138.6	6TPF220ML	2500	
	105	6.3	105		7.3	4.3	2.8			3550	15	0.10	138.6	6TPF220MFL	2500	
	105	6.3	105		7.3	4.3	2.8			2750	25	0.10	138.6	6TPF220MPL	2500	
	105	6.3	105	330	7.3	4.3	2.8		D3L	3900	9	0.10	207.9	6TPF330M9L	2500	
	105	6.3	105		7.3	4.3	2.8			3650	10	0.10	207.9	6TPF330MAL	2500	
	105	6.3	105	470	7.3	4.3	3.8		D4	4400	10	0.10	296.1	6TPF470MAH	2000	
	105	6.3	105		7.3	4.3	3.8			3550	15	0.10	296.1	6TPF470MFH	2000	
10	105	10	105	150	7.3	4.3	2.8	D3L	3600	15	0.10	150.0	10TPF150ML	2500	-	-

*1: Ripple current (100 kHz / +45 °C)

NRFND

Not recommended for new design

*2: ESR (100 kHz / +20 °C)

*3: tan δ (120 Hz / +20 °C)

*4: After 5 minutes

- ◆ Please refer to each page in this catalog for "Reflow conditions", "Taping specifications" and "Floor life level".
- ◆ Small order quantity (500 pcs/reel) is available with TPF series. Please contact our sales representative if you prefer it.

**Conductive Polymer Tantalum
Solid Capacitors**
Surface Mount Type
TQT series

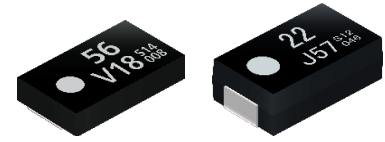

Features

- High voltage (35 V max.)
- Large capacitance
- RoHS compliance, Halogen free

Specifications

Size code	D15S	
Category temp. range	-55 °C ~ +105 °C	
Rated volt. range	35 V	
Category volt. range	35 V	
Rated cap. range	56 μF	
Capacitance tolerance	±20 % (120 Hz / +20 °C)	
Leakage current	Please see the attached characteristics list	
Dissipation factor(tan δ)	Please see the attached characteristics list	
Surge voltage (V)	Rated voltage × 1.15	
Endurance	+105 °C 2000 h rated voltage applied	
	Capacitance change	Within ±20 % of the initial value
	Dissipation factor(tan δ)	≤ 1.5 times of the initial limit
	Leakage current	Within the initial limit
Damp heat (Steady State)	+60 °C, 90 % to 95 % RH, 500 h, No-applied voltage	
	Capacitance change	Within +40 %, -20 % of the initial value
	Dissipation factor(tan δ)	≤ 1.5 times of the initial limit
	Leakage current	≤ 3 times of the initial limit

Marking

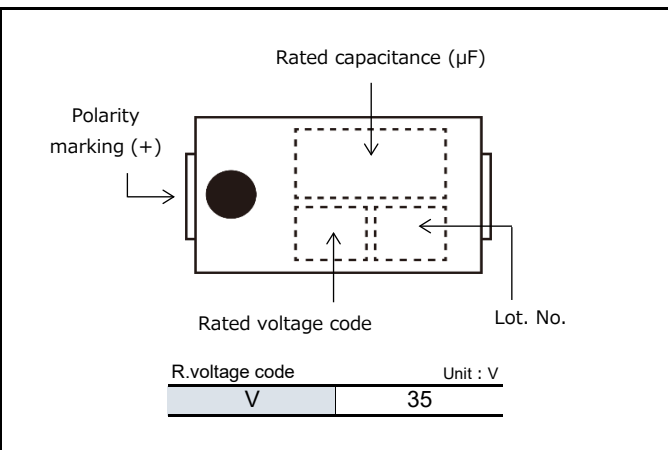

Dimensions (not to scale)

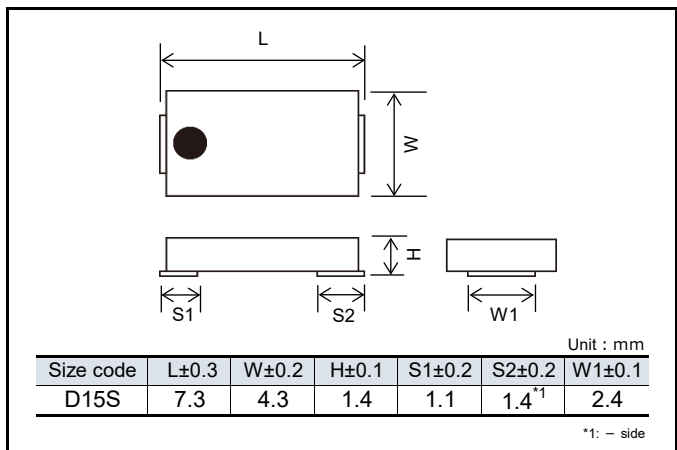

Characteristics list

Rated voltage (V)	Rated temperature (°C)	Category voltage (V)	Category temperature (°C)	Rated capacitance (μF)	Case size (mm)			Size code	Specifications				Standard		Floor life level	Re-flow soldering
					L	W	H		Ripple current ^{*1} (mA rms)	ESR ^{*2} (mΩ max.)	tan δ ^{*3}	LC ^{*4} (μA)	Part number	Min. packaging qty (pcs)		
35	105	35	105	56	7.3	4.3	1.4	D15S	1200	100	0.10	196	35TQT56M	4000	3	A

*1: Ripple current (100 kHz / +105 °C)

*2: ESR (100 kHz / +20 °C)

*3: tan δ (120 Hz / +20 °C)

*4: After 5 minutes

◆ Please refer to each page in this catalog for "Reflow conditions", "Taping specifications" and "Floor life level".

Conductive Polymer Tantalum Solid Capacitors Surface Mount Type TQS series

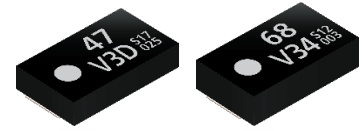

Features

- High voltage (35 V max.)
- RoHS compliance, Halogen free

Specifications

Size code	D15S	D2S
Category temp. range	-55 °C to +105 °C	
Rated voltage range	35 V	
Category voltage range	35 V	
Rated capacitance range	47 μF	68 μF
Capacitance tolerance	±20 % (120 Hz / +20 °C)	
Leakage current	Please see the attached characteristics list	
Dissipation factor(tan δ)	Please see the attached characteristics list	
Surge voltage (V)	Rated voltage × 1.15	
Endurance	+105 °C 2000 h rated voltage applied	
	Capacitance change	Within ±20 % of the initial value
	Dissipation factor(tan δ)	≤ 1.5 times of the initial limit
	Leakage current	Within the initial limit
Damp heat (Steady State)	+60 °C, 90 % to 95 % RH, 500 h, No-applied voltage	
	Capacitance change	Within +40 %, -20 % of the initial value
	Dissipation factor(tan δ)	≤ 1.5 times of the initial limit
	Leakage current	≤ 3 times of the initial limit

Marking

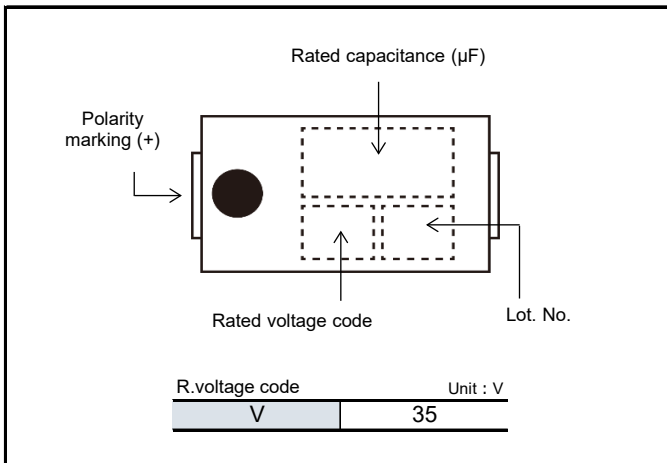

Dimensions (not to scale)

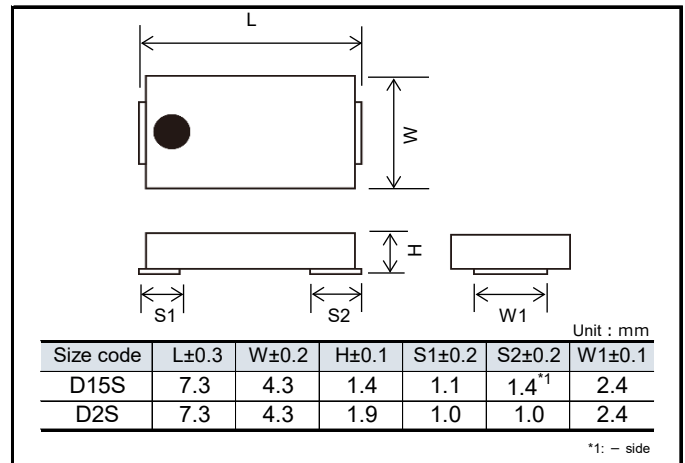

Characteristics list

Rated voltage (V)	Rated temperature (°C)	Category voltage (V)	Category temperature (°C)	Rated capacitance (μF)	Case size (mm)			Size code	Specifications				Standard		Floor life level	Re-flow soldering
					L	W	H		Ripple ^{*1} current (mA rms)	ESR ^{*2} (mΩ max.)	tan δ ^{*3}	LC ^{*4} (μA)	Part number	Min. packaging q'ty (pcs)		
35	105	35	105	47	7.3	4.3	1.4	D15S	1200	100	0.10	164.5	35TQS47MEU	4000	3	A
				47	7.3	4.3	1.4	D15S	1200	100	0.10	164.5	35TQS47MEX	4000		
				68	7.3	4.3	1.9	D2S	1200	100	0.10	238	35TQS68ME2	3000		

^{*1}: Ripple current (100 kHz / +105 °C)

^{*2}: ESR (100 kHz / +20 °C)

^{*3}: tan δ (120 Hz / +20 °C)

^{*4}: After 5 minutes

◆ Please refer to each page in this catalog for "Reflow conditions", "Taping specifications" and "Floor life level".  Not recommended for new design

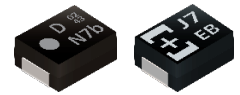

Conductive Polymer Tantalum Solid Capacitors

Surface Mount Type

TQC series B size

Features

- High voltage (35 V max.)
- RoHS compliance, Halogen free

Specifications

Size code	B2	
Category temp. range	-55 °C to +105 °C	
Rated voltage range	16 V to 35 V	
Category voltage range	16 V to 35 V	
Rated capacitance range	10 μF to 47 μF	
Capacitance tolerance	±20 % (120 Hz / +20 °C)	
Leakage current	Please see the attached characteristics list	
Dissipation factor(tan δ)	Please see the attached characteristics list	
Surge voltage (V)	Rated voltage × 1.15	
Endurance	+105 °C 2000 h (16TQC33MYFB : 1000 h), rated voltage applied	
	Capacitance change	Within ±20 % of the initial value
	Dissipation factor(tan δ)	≤ 1.5 times of the initial limit
	Leakage current	Within the initial limit
Damp heat (Steady State)	+60 °C, 90 % to 95 % RH, 500 h, No-applied voltage	
	Capacitance change	Within +40 %, -20 % of the initial value
	Dissipation factor(tan δ)	≤ 1.5 times of the initial limit
	Leakage current	≤ 3 times of the initial limit

Marking

◁ Laser marking ▷

◁ Other than the above ▷

C	16	E	25
D	20	V	35

Unit : V

A7	10	J7	22	S7	47
E7	15	N7	33		

Unit : μF

Dimensions (not to scale)

Size code	L±0.2	W±0.2	H±0.1	S±0.2	W1±0.1
B2	3.5	2.8	1.9	0.8	2.2

Unit : mm

* Externals of figure are the reference.

Characteristics list

Rated voltage (V)	Rated temperature (°C)	Category voltage (V)	Category temperature (°C)	Rated capacitance (µF)	Case size (mm)			Size code	Specifications				Standard		Floor life level	Re-flow soldering
					L	W	H		Ripple current (mA rms) ^{*1}	ESR ^{*2} (mΩ max.)	tan δ ^{*3}	LC ^{*4} (µA)	Part number	Min. packaging q'ty (pcs)		
16	NRFND 105	16	105	15	3.5	2.8	1.9	B2	1000	90	0.10	72.0	16TQC15M	2000	3	D
	NRFND 105	16	105	22	3.5	2.8	1.9		1000	90	0.10	35.2	16TQC22MYFB	2000		
	NRFND 105	16	105	33	3.5	2.8	1.9		1000	90	0.10	158.4	16TQC33MYFB	2000		
	105	16	105		3.5	2.8	1.9		1000	90	0.10	158.4	16TQC33MB2	2000		
	105	16	105	47	3.5	2.8	1.9		1000	90	0.15	225.6	16TQC47MYFB	2000		
20	NRFND 105	20	105	22	3.5	2.8	1.9		1000	90	0.10	132.0	20TQC22MYFB	2000		D
	105	20	105		3.5	2.8	1.9		1000	90	0.10	132.0	20TQC22MB2	2000	A	
	105	20	105	33	3.5	2.8	1.9		900	100	0.10	198.0	20TQC33MYFB	2000		
25	NRFND 105	25	105	10	3.5	2.8	1.9		900	100	0.10	25.0	25TQC10MEB	2000	D	
	NRFND 105	25	105	15	3.5	2.8	1.9		900	100	0.10	112.5	25TQC15MYFB	2000		
	105	25	105		3.5	2.8	1.9		900	100	0.10	112.5	25TQC15MB	2000		
	105	25	105	22	3.5	2.8	1.9		1100	100	0.10	165.0	25TQC22MYFB	2000		
35	105	35	105	10	3.5	2.8	1.9	900	150	0.15	105.0	35TQC10MYFB	2000	A		
	105	35	105		3.5	2.8	1.9	750	200	0.15	105.5	35TQC10MXB	2000			

*1: Ripple current (100 kHz / +105 °C)

*2: ESR (100 kHz / +20 °C)

*3: tan δ (120 Hz / +20 °C)

*4: After 5 minutes

NRFND Not recommended for new design

◆ Please refer to each page in this catalog for "Reflow conditions", "Taping specifications" and "Floor life level".

◆ Small order quantity (500 pcs/reel) is available with TQC series. Please contact our sales representative if you prefer it.



Some part numbers are not a recommended product.
Not recommended for new design.

Conductive Polymer Tantalum Solid Capacitors

Surface Mount Type

TQC series D size



Features

- High voltage (35 V max.)
- RoHS compliance, Halogen free

Specifications

Size code	D15	D2	D3L
Category temp. range	-55 °C to +105 °C		
Rated voltage range	16 V to 25 V	16 V to 35 V	16 V to 25 V
Category voltage range	16 V to 25 V	16 V to 35 V	16 V to 25 V
Rated capacitance range	22 µF to 47 µF	10 µF to 150 µF	68 µF to 220 µF
Capacitance tolerance	±20 % (120 Hz / +20 °C)		
Leakage current	Please see the attached characteristics list		
Dissipation factor(tan δ)	Please see the attached characteristics list		
Surge voltage (V)	Rated voltage × 1.15		
Endurance	+105 °C 2000 h rated voltage applied		
	Capacitance change	Within ±20 % of the initial value	
	Dissipation factor(tan δ)	≤ 1.5 times of the initial limit	
	Leakage current	Within the initial limit	
Damp heat (Steady State)	+60 °C, 90 % to 95 % RH, 500 h, No-applied voltage		
	Capacitance change	Within +40 %, -20 % of the initial value	
	Dissipation factor(tan δ)	≤ 1.5 times of the initial limit	
	Leakage current	≤ 3 times of the initial limit	

Marking

Diagram illustrating marking schemes for surface-mount tantalum capacitors.

〈 Laser marking 〉

Rated capacitance (µF)

Polarity marking (+)

Rated voltage code

Lot. No.

〈 Other than the above 〉

Rated capacitance (µF)

Polarity marking (+)

Rated voltage code

Lot. No.

R. voltage code		Unit : V	
C	16	E ¹ , 1E	25
D	20	V	35

*1: Laser marking

Dimensions (not to scale)

Size code	L	W±0.2	H	S±0.2	W1±0.1
D15	7.3±0.2	4.3	1.4±0.1	1.3	2.4
D2	7.3±0.2	4.3	1.9±0.1	1.3	2.4
D3L	7.3±0.3	4.3	2.8±0.2	1.3	2.4

Unit : mm

* Externals of figure are the reference.

Characteristics list

Rated voltage (V)	Rated temperature (°C)	Category voltage (V)	Category temperature (°C)	Rated capacitance (µF)	Case size (mm)			Size code	Specifications				Standard		Floor life level	Re-flow soldering			
					L	W	H		Ripple ^{*1} current (mA rms)	ESR ^{*2} (mΩ max.)	tan δ ^{*3}	LC ^{*4} (µA)	Part number	Min. packaging qty (pcs)					
16	105	16	105	47	7.3	4.3	1.4	D15	1500	55	0.10	75.2	16TQC47MYFT	3000	3	D			
	NEW 105	16	105		7.3	4.3	1.9		D2	1450	55	0.10	75.2	16TQC47MD2		3000	A		
	NEW 105	16	105		7.3	4.3	1.9			1250	70	0.10	75.2	16TQC47MBD2		3000			
	NEW 105	16	105	68	7.3	4.3	1.9	1500		50	0.10	108.8	16TQC68MD2	3000					
	NEW 105	16	105	100	7.3	4.3	1.9	1800		50	0.10	160.0	16TQC100MD2	3000					
	105	16	105	150	7.3	4.3	1.9	D3L	1500	70	0.15	240.0	1CTQC15173F1	3000		D			
	105	16	105		7.3	4.3	2.8		1800	50	0.10	240.0	16TQC150MD3	2500		B			
105	16	105	220		7.3	4.3	2.8		1750	50	0.10	352.0	16TQC220MD3	2500	C				
20	105	20	105	22	7.3	4.3	1.9	D2	1200	90	0.10	44.0	20TQC22MQD	3000	D				
	NEW 105	20	105		33	7.3	4.3		1.9	1400	60	0.10	66.0	20TQC33MD2	3000	A			
	105	20	105	47	7.3	4.3	1.4	D15	1500	55	0.10	94.0	20TQC47MYFT	3000	D				
					NEW 105	20	105		7.3	4.3	1.9	D2	1450	55	0.10	94.0	20TQC47MD2	3000	A
					105	20	105		100	7.3	4.3		1.9	1250	100	0.15	200.0	20TQC100MD2	3000
105	20	105	100	7.3	4.3	2.8	D3L	1700	55	0.10	200.0	20TQC100MD3	2500	B					
25	NEW 105	25	105	15	7.3	4.3	1.9	D2	1000	90	0.10	37.5	25TQC15MD2	3000	A				
	NEW 105	25	105		22	7.3	4.3		1.9	1400	60	0.10	55.0	25TQC22MD2		3000			
	NEW 105	25	105		33	7.3	4.3		1.9	1400	60	0.10	82.5	25TQC33MD2		3000			
	105	25	105	68	7.3	4.3	2.8	D3L	1400	70	0.10	170.0	25TQC68MD3	2500	B				
	105	25	105		100	7.3	4.3		2.8	1600	60	0.10	250.0	25TQC100MD3	2500	C			
35	NEW 105	35	105	10	7.3	4.3	1.9	D2	820	180	0.10	35.0	35TQC10MD2	3000	A				
	NEW 105	35	105		15	7.3	4.3		1.9	900	150	0.10	52.5	35TQC15MD2		3000			
	NEW 105	35	105		22	7.3	4.3		1.9	900	150	0.10	77.0	35TQC22MD2		3000			

NRFND [Not recommended for new design]

16	105	16	105	33	7.3	4.3	1.9	D2	1400	70	0.10	52.8	16TQC33MYFD	3000	3	D		
	105	16	105		47	7.3	4.3		1.9	1450	55	0.10	75.2	16TQC47MYFD			3000	
	105	16	105			7.3	4.3		1.9	1250	70	0.10	75.2	16TQC47MBD			3000	
	105	16	105	68	7.3	4.3	1.9		1500	50	0.10	108.8	16TQC68MYF	3000				
	105	16	105	100	7.3	4.3	1.9		1800	50	0.10	160.0	16TQC100MYF	3000				
	105	16	105	150	7.3	4.3	2.8		D3L	1800	50	0.10	240.0	16TQC150MYF			2500	
20	105	20	105	33	7.3	4.3	1.9	D2	1400	60	0.10	66.0	20TQC33MYFD	3000	3	D		
	105	20	105		47	7.3	4.3		1.9	1450	55	0.10	94.0	20TQC47MYF			3000	
	105	20	105		100	7.3	4.3		2.8	D3L	1700	55	0.10	200.0			20TQC100MYF	2500
25	105	25	105	15	7.3	4.3	1.9	D2	1000	90	0.10	38.0	25TQC15MYFD	3000	3	D		
	105	25	105		22	7.3	4.3		1.9	1400	60	0.10	55.0	25TQC22MYFD			3000	
	105	25	105	22	7.3	4.3	1.4	D15	1400	70	0.10	55.0	25TQC22MYFT	3000				
	105	25	105		33	7.3	4.3		1.9	D2	1400	60	0.10	82.5			25TQC33MYF	3000
	105	25	105		68	7.3	4.3		2.8	D3L	1400	70	0.10	170.0			25TQC68MYF	2500
35	105	35	105	10	7.3	4.3	1.9	D2	1000	120	0.10	35.0	35TQC10MYF	3000	3	D		
	105	35	105		15	7.3	4.3		1.9	900	150	0.10	52.5	35TQC15MYF			3000	

*1: Ripple current (100 kHz / +105 °C)

*2: ESR (100 kHz / +20 °C)

*3: tan δ (120 Hz / +20 °C)

*4: After 5 minutes

◆ Please refer to each page in this catalog for "Reflow conditions", "Taping specifications" and "Floor life level".

◆ Small order quantity (500 pcs/reel) is available with TQC series. Please contact our sales representative if you prefer it.

Conductive Polymer Tantalum Solid Capacitors Surface Mount Type TA series

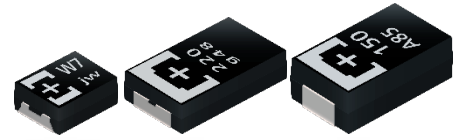

■ This product is not intended for use in any driving application or any other critical functions that affect passenger safety.(e.g. Powertrain, ABS, Engine ECU, Airbag, etc.)
If the intended use of TA/TV series products is for use in other automotive related applications, please contact our sales team. All requests are subject to approval.

Features

- Guaranteed at 85 °C 85 %RH
- RoHS compliance, Halogen free

Specifications

Size code	B2	D2E	D3L
Category temp. range	-55 °C to +105 °C		
Rated voltage range	4.0 V to 10 V	2.5 V to 6.3 V	2.5 V to 10 V
Category voltage range	4.0 V to 10 V	2.5 V to 6.3 V	2.5 V to 10 V
Rated capacitance range	47 μF to 100 μF	150 μF to 470 μF	150 μF to 680 μF
Capacitance tolerance	±20 % (120 Hz / +20 °C)		
Leakage current	Please see the attached characteristics list		
Dissipation factor(tan δ)	Please see the attached characteristics list		
Surge voltage (V)	Rated voltage × 1.15		
Endurance	+105 °C 2000 h (B2 size : 1000 h) , rated voltage applied		
	Capacitance change	Within ±20 % of the initial value	
	Dissipation factor(tan δ)	≤ 1.5 times of the initial limit	
	Leakage current	Within the initial limit	
Damp heat (Steady State)	+85 °C, 85 % to 90 % RH, 500 h, rated voltage applied		
	Capacitance change	Within +50 %, -20 % of the initial value (2R5TAE470M (F), 2R5TAE330M (I, F), 2R5TAE220M (F, 9))	
	Dissipation factor(tan δ)	≤ 1.5 times of the initial limit	
	Leakage current	Within the initial limit	

Marking

< B2 size >

< D2E, D3L size >

e	2.5
g	4

j	6.3
A	10

S7	47
W7	68

A8	100
----	-----

Dimensions (not to scale)

Size code	L	W±0.2	H	S±0.2	W1±0.1
B2	3.5±0.2	2.8	1.9±0.1	0.8	2.2
D2E	7.3±0.3	4.3	1.8±0.1	1.3	2.4
D3L	7.3±0.3	4.3	2.8±0.2	1.3	2.4

* Externals of figure are the reference.

Characteristics list

Rated voltage (V)	Rated temperature (°C)	Category voltage (V)	Category temperature (°C)	Rated capacitance (μF)	Case size (mm)			Size code	Specifications				Standard		Floor life level		
					L	W	H		Ripple ^{*1} current (mA rms)	ESR ^{*2} (mΩ max.)	tan δ ^{*3}	LC ^{*4} (μA)	Part number	Min. packaging qty (pcs)	Reflow temp ≤260°C	Reflow temp ≤250°C	
2.5	105	2.5	105	220	7.3	4.3	1.8	D2E	3900	9	0.10	110.0	2R5TAE220M9	3000	3	3	
	105	2.5	105		7.3	4.3	1.8		3100	15	0.10	55.0	2R5TAE220MF	3000			
	105	2.5	105		7.3	4.3	1.8		2400	25	0.10	55.0	2R5TAE220M	3000			
	105	2.5	105	330	7.3	4.3	1.8		3100	15	0.10	82.5	2R5TAE330MF	3000			
	105	2.5	105		7.3	4.3	1.8		2800	18	0.10	82.5	2R5TAE330MI	3000			
	105	2.5	105		7.3	4.3	1.8		2400	25	0.10	82.5	2R5TAE330M	3000			
	105	2.5	105	470	7.3	4.3	1.8		3100	15	0.10	117.5	2R5TAE470MF	3000			
	105	2.5	105		7.3	4.3	1.8		2400	25	0.10	117.5	2R5TAE470M	3000			
	105	2.5	105	680	7.3	4.3	2.8		D3L	3100	15	0.10	170.0	2R5TAE680MFL			2500
	105	2.5	105		7.3	4.3	2.8			2400	25	0.10	170.0	2R5TAE680ML			2500
4.0	105	4.0	105	100	3.8	2.8	1.9	B2	1100	70	0.08	40.0	4TAB100M	2000	3	3	
	105	4.0	105	220	7.3	4.3	1.8	D2E	2800	18	0.10	88.0	4TAE220MI	3000			
	105	4.0	105		7.3	4.3	1.8		2400	25	0.10	88.0	4TAE220M	3000			
	105	4.0	105	470	7.3	4.3	2.8	D3L	2800	18	0.10	188.0	4TAE470MIL	2500			
	105	4.0	105		7.3	4.3	2.8		2400	25	0.10	188.0	4TAE470ML	2500			
6.3	105	6.3	105	47	3.5	2.8	1.9	B2	1100	70	0.08	29.6	6TAB47M	2000	3	3	
	105	6.3	105	68	3.5	2.8	1.9		1100	70	0.08	42.8	6TAB68M	2000			
	105	6.3	105	150	7.3	4.3	1.8	D2E	2400	25	0.10	94.5	6TAE150M	3000			
	105	6.3	105	220	7.3	4.3	1.8		2800	18	0.10	138.6	6TAE220MI	3000			
	105	6.3	105		7.3	4.3	1.8		2400	25	0.10	138.6	6TAE220M	3000			
	105	6.3	105	330	7.3	4.3	2.8		D3L	2400	25	0.10	207.9	6TAE330ML			2500
	105	6.3	105		7.3	4.3	2.8			2400	25	0.10	207.9	6TAE330ML			2500
10	105	10	105	47	3.5	2.8	1.9	B2	1100	70	0.08	47.0	10TAB47M	2000	3	3	
	105	10	105	150	7.3	4.3	2.8	D3L	2400	25	0.10	150.0	10TAE150ML	2500			
	105	10	105	220	7.3	4.3	2.8		2400	25	0.10	220.0	10TAE220ML	2500			

*1: Ripple current (100 kHz / +45 °C)

*2: ESR (100 kHz / +20 °C)

*3: tan δ (120 Hz / +20 °C)

*4: After 5 minutes

◆ Please refer to each page in this catalog for "Reflow conditions", "Taping specifications" and "Floor life level".

Conductive Polymer Tantalum Solid Capacitors Surface Mount Type TV series

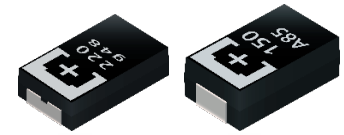

■ This product is not intended for use in any driving application or any other critical functions that affect passenger safety.(e.g. Powertrain, ABS, Engine ECU, Airbag, etc.)
If the intended use of TA/TV series products is for use in other automotive related applications, please contact our sales team. All requests are subject to approval.

Features

- Guaranteed at 85 °C 85 %RH
- Guaranteed at 125 °C
- RoHS compliance, Halogen free

Specifications

Size code	D2E	D3L
Category temp. range	-55 °C to +125 °C	
Rated voltage range	6.3 V to 10 V	10 V
Category voltage range	4.0 V to 6.3 V	6.3 V
Rated capacitance range	68 µF to 150 µF	150 µF
Capacitance tolerance	±20 % (120 Hz / +20 °C)	
Leakage current	Please see the attached characteristics list	
Dissipation factor(tan δ)	Please see the attached characteristics list	
Surge voltage (V)	Rated voltage × 1.15	
Endurance	+125 °C 1000 h, category voltage applied (+105 °C 2000 h, rated voltage applied)	
	Temperature	125 °C
	Capacitance change	Within ±20% of the initial value
	Dissipation factor(tan δ)	≤ 2 times of the initial limit
Damp heat (Steady State)	+85 °C, 85 % to 90 % RH, 500 h, rated voltage applied	
	Capacitance change	Within +40 %, -20 % of the initial value
	Dissipation factor(tan δ)	≤ 1.5 times of the initial limit
	Leakage current	Within the initial limit

Marking

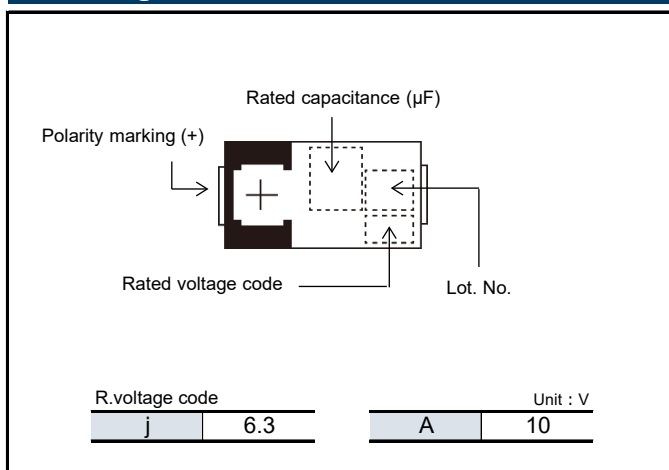

Dimensions (not to scale)

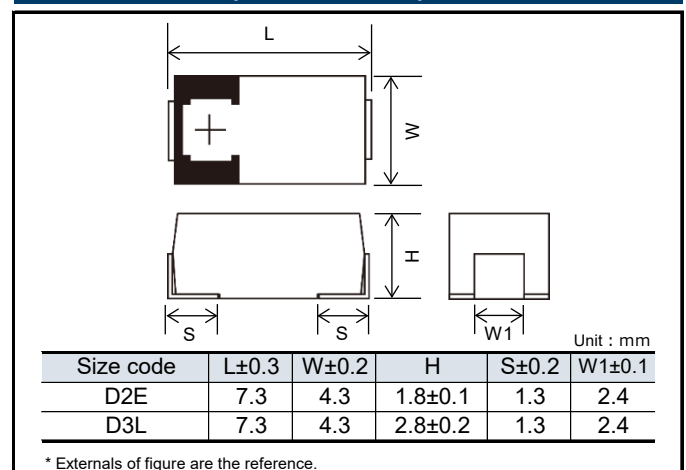

Characteristics list

Rated voltage (V)	Rated temperature (°C)	Category voltage (V)	Category temperature (°C)	Rated capacitance (µF)	Case size (mm)			Size code	Specifications				Standard		Floor life level	
					L	W	H		Ripple current ^{*1} (mA rms)	ESR ^{*2} (mΩ max.)	tan δ ^{*3}	LC ^{*4} (µA)	Part number	Min. packaging q'ty (pcs)	Reflow temp ≤260°C	Reflow temp ≤250°C
6.3	105	4.0	125	150	7.3	4.3	1.8	D2E	2400	25	0.10	94.5	6TVE150M	3000	5	3
10	105	6.3	125	150	7.3	4.3	2.8	D3L	2400	25	0.10	150.0	10TVE150ML	2500		

*1: Ripple current (100 kHz / +45 °C)

*2: ESR (100 kHz / +20 °C)

*3: tan δ (120 Hz / +20 °C)

*4: After 5 minutes

◆ Please refer to each page in this catalog for "Reflow conditions", "Taping specifications" and "Floor life level".

Conductive Polymer Tantalum Solid Capacitors Surface Mount Type TH series

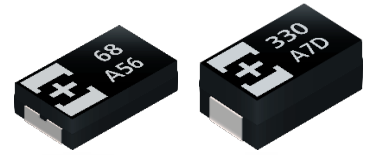

Features

- Guaranteed at 125 °C 1000 h
- RoHS compliance, Halogen free

Specifications

Size code	D2E	D2	D3L	D4
Category temp. range	-55 °C to +125 °C			
Rated voltage range	2.5 V to 6.3 V	2.5 V to 10 V	4.0 V to 6.3 V	6.3 V to 10 V
Category voltage range	1.6 V to 4.0 V	1.6 V to 6.3 V	2.5 V to 4.0 V	4.0 V to 6.3 V
Rated capacitance range	150 μF to 330 μF	68 μF to 220 μF	220 μF to 330 μF	220 μF to 470 μF
Capacitance tolerance	±20 % (120 Hz / +20 °C)			
Leakage current	Please see the attached characteristics list			
Dissipation factor(tan δ)	Please see the attached characteristics list			
Surge voltage (V)	Rated voltage × 1.15			
Endurance	+125 °C 1000 h, category voltage applied			
	Capacitance change	Within ±20 % of the initial value		
	Dissipation factor(tan δ)	≤ 2 times of the initial limit		
	Leakage current	≤ 2 times of the initial limit		
Damp heat (Steady State)	+60 °C, 90 % to 95 % RH, 500 h, No-applied voltage			
	Capacitance change	Within +40 %, -20 % of the initial value		
	Dissipation factor(tan δ)	≤ 1.5 times of the initial limit		
	Leakage current	≤ 3 times of the initial limit		

Marking

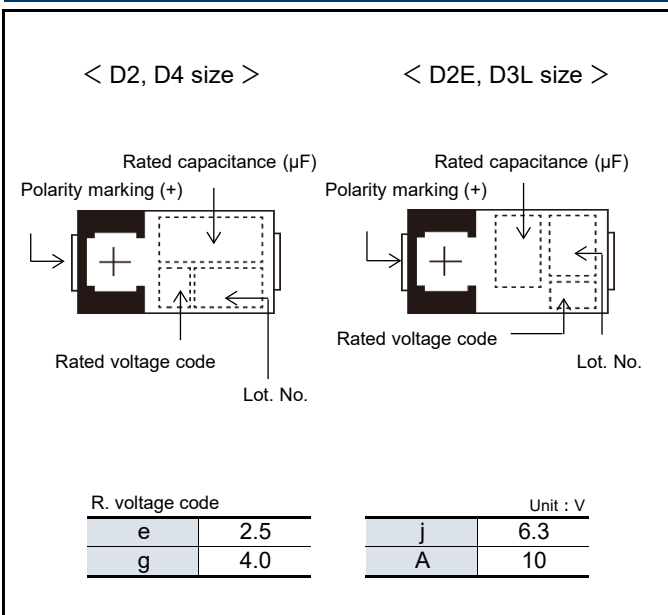

Dimensions (not to scale)

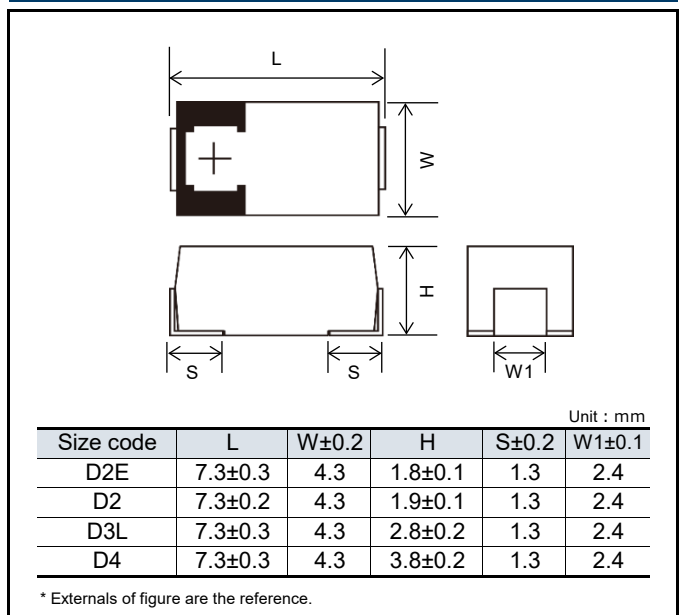

Characteristics list

Series	Rated voltage (V)	Rated temperature (°C)	Category voltage (V)	Category temp. (°C)	Rated capacitance (μF)	Case size (mm)			Size code	Specifications				Standard		Floor life level	
						L	W	H		Ripple ^{*1} current (mA rms)	ESR ^{*2} (mΩ max.)	tan δ ^{*3}	LC ^{*4} (μA)	Part number	Min. packaging q'ty (pcs)	Reflow temp ≤260°C	Reflow temp ≤250°C
THB	4.0	105	2.5	125	330	7.3	4.3	2.8	D3L	2000	40	0.10	132.0	4THB330ML	2500	-	5
	6.3	105	4.0	125	220	7.3	4.3	2.8		2000	40	0.10	138.6	6THB220ML	2500		
		10	105	4.0	125	330	7.3	4.3	3.8	D4	3000	40	0.10	207.9	6THB330M		
	105		4.0	125	470	7.3	4.3	3.8	3000		35	0.10	296.1	6THB470M	2000		
	105		6.3	125	220	7.3	4.3	3.8	3000		40	0.10	220.0	10THB220M	2000		
	105		6.3	125	330	7.3	4.3	3.8	3000		35	0.10	330.0	10THB330M	2000		
THC	2.5	105	1.6	125	220	7.3	4.3	1.9	D2	1700	45	0.10	55.0	2R5THC220M	3000		
	10	105	6.3	125	68	7.3	4.3	1.9		1700	45	0.10	68.0	10THC68M	3000		
THE	2.5	105	1.6	125	330	7.3	4.3	1.8	D2E	3100	15	0.10	82.5	2R5THE330MF	3000		
		105	1.6	125		7.3	4.3	1.8		2800	18	0.10	82.5	2R5THE330MI	3000		
		105	1.6	125		7.3	4.3	1.8		2400	25	0.10	82.5	2R5THE330M	3000		
	4.0	105	2.5	125	220	7.3	4.3	1.8		3100	15	0.10	88.0	4THE220MF	3000		
		105	2.5	125		7.3	4.3	1.8		2800	18	0.10	88.0	4THE220MI	3000		
		105	2.5	125		7.3	4.3	1.8		2400	25	0.10	88.0	4THE220M	3000		
	6.3	105	4.0	125	150	7.3	4.3	1.8		2800	18	0.10	94.5	6THE150MI	3000		
		105	4.0	125		7.3	4.3	1.8		2400	25	0.10	94.5	6THE150M	3000		

*1: Ripple current (100 kHz / +45 °C)

*2: ESR (100 kHz / +20 °C)

*3: tan δ (120 Hz / +20 °C)

*4: After 5 minutes

◆ Please refer to each page in this catalog for "Reflow conditions", "Taping specifications" and "Floor life level".

Conductive Polymer Tantalum Solid Capacitors Surface Mount Type TPB series

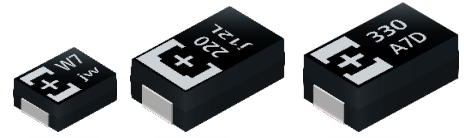

Features

- Standard
- RoHS compliance, Halogen free

Specifications

Size code	B2	D3L	D4
Category temp. range	-55 °C to +105 °C		
Rated voltage range	4.0 V to 10 V	4.0 V to 10 V	6.3 V to 10 V
Category voltage range	4.0 V to 10 V	4.0 V to 10 V	6.3 V to 10 V
Rated capacitance range	33 μF to 68 μF	150 μF to 330 μF	220 μF to 470 μF
Capacitance tolerance	±20 % (120 Hz / +20 °C)		
Leakage current	Please see the attached characteristics list		
Dissipation factor(tan δ)	Please see the attached characteristics list		
Surge voltage (V)	Rated voltage × 1.15		
Endurance	+105 °C 2000 h, (B2 size : 1000 h) rated voltage applied Rated temp. +85 °C 1000 h rated voltage applied		
	Capacitance change	Within ±20 % of the initial value	
	Dissipation factor(tan δ)	≤ 1.5 times of the initial limit	
	Leakage current	Within the initial limit	
Damp heat (Steady State)	+60 °C, 90 % to 95 % RH, 500 h, No-applied voltage		
	Capacitance change	Within +40 %, -20 % of the initial value (Except for above model)	
	Dissipation factor(tan δ)	≤ 1.5 times of the initial limit	
	Leakage current	≤ 3 times of the initial limit	

Marking

< B2 size >

Rated capacitance code

Polarity marking (+)

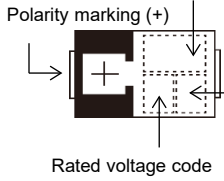

Rated voltage code Lot. No.

< D3L size >

Rated capacitance (μF)

Polarity marking (+)

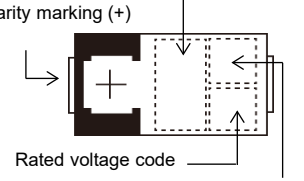

Rated voltage code Lot. No.

< D4 size >

Rated capacitance (μF)

Polarity marking (+)

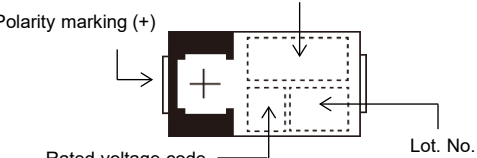

Rated voltage code Lot. No.

R. voltage code	Unit : V
g 4.0 j 6.3 A 10	

R. capacitance code	Unit : μF
< B2 size > N7 33 S7 47 W7 68	

Dimensions (not to scale)

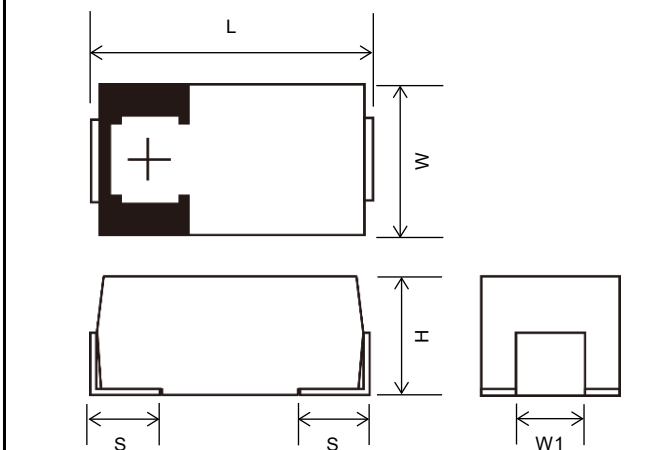

Size code	L	W±0.2	H	S±0.2	W1±0.1
B2	3.5±0.2	2.8	1.9±0.1	0.8	2.2
D3L	7.3±0.3	4.3	2.8±0.2	1.3	2.4
D4	7.3±0.3	4.3	3.8±0.2	1.3	2.4

* Externals of figure are the reference.

Characteristics list

Rated voltage (V)	Rated temperature (°C)	Category voltage (V)	Category temperature (°C)	Rated capacitance (µF)	Case size (mm)			Size code	Specifications				Standard		Floor life level	
					L	W	H		Ripple ^{*1} current (mA rms)	ESR ^{*2} (mΩ max.)	tan δ ^{*3}	LC ^{*4} (µA)	Part number	Min. packaging q'ty (pcs)	Reflow temp ≤260°C	Reflow temp ≤250°C
4.0	105	4.0	105	68	3.5	2.8	1.9	B2	1100	70	0.08	27.2	4TPB68M	2000		3
	NRFND 105	4.0	105	330	7.3	4.3	2.8	D3L	2000	40	0.10	132	4TPB330ML	2500		2a
6.3	105	6.3	105	33	3.5	2.8	1.9	B2	1100	70	0.08	20.7	6TPB33M	2000	3	3
	105	6.3	105	68	3.5	2.8	1.9		1100	70	0.08	42.8	6TPB68M	2000		
	NRFND 105	6.3	105	220	7.3	4.3	2.8	D3L	2000	40	0.10	138.6	6TPB220ML	2500		
	NRFND 105	6.3	105		7.3	4.3	2.8		1750	50	0.10	138.6	6TPB220MTL	2500		
	85	5.0	105	330	7.3	4.3	2.8	D3L	2000	40	0.10	207.9	6TPB330MAL	2500		2a
	105	6.3	105		7.3	4.3	2.8		2000	40	0.10	207.9	6TPB330ML	2500		
	105	6.3	105		7.3	4.3	3.8	D4	3000	40	0.10	207.9	6TPB330M	2000		
	105	6.3	105		7.3	4.3	2.8	D3L	1850	45	0.10	207.9	6TPB330MVL	2500		
	105	6.3	105	470	7.3	4.3	3.8	D4	3000	35	0.15	296.1	6TPB470M	2000		
	10	105	10	105	33	3.5	2.8	1.9	B2	1100	70	0.08	33.0	10TPB33M		2000
105		10	105	47	3.5	2.8	1.9	1100		70	0.08	47.0	10TPB47M	2000		
105		10	105	150	7.3	4.3	2.8	D3L	2000	40	0.10	150.0	10TPB150ML	2500		
105		10	105		7.3	4.3	2.8		1700	55	0.10	150.0	10TPB150MGL	2500		
105		10	105	220	7.3	4.3	2.8	D3L	2000	40	0.10	220.0	10TPB220ML	2500	-	
105		10	105		7.3	4.3	3.8		3000	40	0.10	220.0	10TPB220M	2000	3	
NRFND 105		10	105	330	7.3	4.3	3.8	D4	3000	35	0.10	330.0	10TPB330M	2000	-	
105	10	105	7.3		4.3	3.8	2800		40	0.10	330.0	10TPB330MW	2000	-		

*1: Ripple current (100 kHz / +45 °C)

NRFND Not recommended for new design

*2: ESR (100 kHz / +20 °C)

*3: tan δ (120 Hz / +20 °C)

*4: After 5 minutes

◆ Please refer to each page in this catalog for "Reflow conditions", "Taping specifications" and "Floor life level".

Conductive Polymer Tantalum Solid Capacitors Surface Mount Type TC series

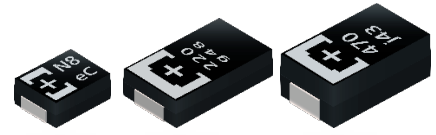

Features

- Guaranteed at 125 °C 1000 h
- RoHS compliance, Halogen free

Specifications

Size code	B2	D2E	D3L	D4
Category temp. range	-55 °C to +125 °C			
Rated voltage range	2.5 V	4.0 V to 6.3 V	2.5 V to 10 V	
Category voltage range	2.0 V	3.2 V to 5.0 V	2.0 V to 8.0 V	
Rated capacitance range	330 μF	100 μF to 330 μF	150 μF to 680 μF	330 μF to 1000 μF
Capacitance tolerance	±20 % (120 Hz / +20 °C)			
Leakage current	Please see the attached characteristics list			
Dissipation factor(tan δ)	Please see the attached characteristics list			
Surge voltage (V)	Rated voltage × 1.15			
Endurance	+125 °C 1000 h, category voltage applied			
	Capacitance change	Within ±20 % of the initial value		
	Dissipation factor(tan δ)	≤ 2 times of the initial limit		
	Leakage current	≤ 2 times of the initial limit		
Damp heat (Steady State)	+60 °C, 90 % to 95 % RH, 500 h, No-applied voltage			
	Capacitance change	Within +50 %, -20 % of the initial value (ETCF1000M6H(5H))		
		Within +40 %, -20 % of the initial value		
	Dissipation factor(tan δ)	≤ 1.5 times of the initial limit		
Leakage current	≤ 3 times of the initial limit			

Marking

< B2 size >

< D2E, D3L, D4 size >

e	2.5
g	4.0

j	6.3
A	10

< B2 size >

N8	330
----	-----

Dimensions (not to scale)

Size code	L	W±0.2	H	S±0.2	W1±0.1
B2	3.5±0.2	2.8	1.9±0.1	0.8	2.2
D2E	7.3±0.3	4.3	1.8±0.1	1.3	2.4
D3L	7.3±0.3	4.3	2.8±0.2	1.3	2.4
D4	7.3±0.3	4.3	3.8±0.2	1.3	2.4

* Externals of figure are the reference.

Characteristics list

Series	Rated voltage (V)	Rated temperature (°C)	Category voltage (V)	Category temp. (°C)	Rated capacitance (µF)	Case size (mm)			Size code	Specifications				Standard		Floor life level			
						L	W	H		Ripple current (mA rms)	ESR* ² (mΩ max.)	tan δ* ³	LC* ⁴ (µA)	Part number	Min. packaging q'ty (pcs)	Reflow temp ≤260°C	Reflow temp ≤250°C		
TCE	2.5	105	2.0	125	330	3.5	2.8	1.9	B2	3200	9/300kHz	0.08	165.0	ETCE330M9GB	2000	3	2a		
						680	7.3	4.3	2.8	D3L	3500	12	0.10	170.0	ETCE680MCL			2500	
					7.3		4.3	2.8	3100		15	0.10	170.0	ETCE680MFL	2500				
					4.0	105	2.0	125	1000	7.3	4.3	3.8	D4	3900	15			0.15	250.0
	150	7.3	4.3	1.8						D2E	2800	18	0.10	60.0	4TCE150MI			3000	
		7.3	4.3	1.8		3100	15	0.10	88.0		4TCE220MF	3000							
		220	7.3	4.3		1.8	2800	18	0.10		88.0	4TCE220MI	3000						
			7.3	4.3		1.8	2400	25	0.10		88.0	4TCE220M	3000						
	330	105	3.2	125		330	7.3	4.3	1.8	D3L	2800	18	0.10	132.0	4TCE330MI			3000	
							7.3	4.3	1.8		2400	25	0.10	132.0	4TCE330M			3000	
		470	7.3	4.3		2.8	3500	12	0.10		188.0	4TCE470MCL	2500						
			7.3	4.3		2.8	3100	15	0.10		188.0	4TCE470MFL	2500						
	6.3	105	5.0	125		100	7.3	4.3	1.8	D2E	2800	18	0.10	63.0	6TCE100MI			3000	
							7.3	4.3	1.8		2400	25	0.10	63.0	6TCE100M			3000	
		150	7.3	4.3		1.8	3100	15	0.10		94.5	6TCE150MF	3000						
			7.3	4.3		1.8	2800	18	0.10		94.5	6TCE150MI	3000						
		220	105	5.0		125	220	7.3	4.3	1.8	D3L	2400	25	0.15	94.5			6TCE150M	3000
								7.3	4.3	1.8		2800	18	0.15	138.6			6TCE220MI	3000
			330	7.3		4.3	1.8	2400	25	0.15		138.6	6TCE220M	3000					
				7.3	4.3	2.8	3100	15	0.10	207.9		6TCE330MFL	2500						
		470	105	5.0	125	470	7.3	4.3	2.8	D4	2800	18	0.10	207.9	6TCE330MIL			2500	
							7.3	4.3	2.8		2400	25	0.10	207.9	6TCE330ML			2500	
			680	7.3	4.3	3.8	3500	18	0.15		296.1	6TCE470MI	2000						
				7.3	4.3	3.8	3000	25	0.15		296.1	6TCE470M	2000						
			105	5.0	125	680	7.3	4.3	3.8	D4	3500	18	0.15	428.4	6TCE680MI			2000	
							7.3	4.3	3.8		3000	25	0.15	428.4	6TCE680M			2000	
	10	105	8.0	125	220	7.3	4.3	2.8	D3L	2800	18	0.10	220.0	10TCE220MIL	2500				
						7.3	4.3	2.8		2400	25	0.10	220.0	10TCE220ML	2500				
		105	8.0	125	330	7.3	4.3	3.8	D4	3000	25	0.10	330.0	10TCE330M	2000				
	TCF	2.5	105	2.0	125	680	7.3	4.3	2.8	D3L	4400	6	0.10	170.0	ETCF680M6L			2500	
4400											7	0.10	170.0	ETCF680M7L	2500				
4400											10	0.10	170.0	ETCF680ML	2500				
1000							7.3	4.3	3.8	D4	6100	5	0.10	170.0	ETCF680M5H	2000			
											6100	5	0.10	250.0	ETCF1000M5H	2000			
											5600	6	0.10	250.0	ETCF1000M6H	2000			
4.0		105	3.2	125	330	7.3	4.3	2.8	D3L	4000	12	0.10	132.0	4TCF330ML	2500				
						7.3	4.3	2.8		4400	10	0.10	188.0	4TCF470ML	2500				
		105	3.2	125	680	7.3	4.3	3.8	D4	4400	10	0.10	272.0	4TCF680MAH	2000				
6.3		105	5.0	125	220	7.3	4.3	2.8	D3L	4600	9	0.10	138.6	6TCF220M9L	2500				
										4000	12	0.10	138.6	6TCF220ML	2500				
		330	105	5.0	125	330	7.3	4.3	2.8	D3L	3900	9	0.10	207.9	6TCF330M9L	2500			
	4400										10	0.10	296.1	6TCF470MAH	2000				
105	5.0	125	470	7.3	4.3	3.8	D4	4400	10	0.10	296.1	6TCF470MAH	2000						
10	105	8.0	125	150	7.3	4.3	2.8	D3L	3600	15	0.10	150.0	10TCF150ML	2500	-	-			

*1: Ripple current (100 kHz / +45 °C)

*2: ESR (100 kHz / +20 °C)

*3: tan δ (120 Hz / +20 °C)

*4: After 5 minutes

◆ Please refer to each page in this catalog for "Reflow conditions", "Taping specifications" and "Floor life level".

NRFND Not recommended for new design

 Some part numbers are not a recommended product.
Not recommended for new design.

Conductive Polymer Tantalum Solid Capacitors Surface Mount Type TDC series

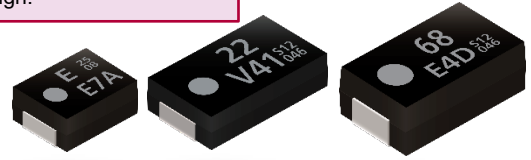

Features

- Guaranteed at 125 °C 1000 h
- High voltage (35 V max.)
- RoHS compliance, Halogen free

Specifications

Size code	B2	D2	D3L
Category temp. range	-55 °C to +125 °C		
Rated voltage range	16 V to 25 V	16 V to 35 V	16 V to 25 V
Category voltage range	12.8 V to 20 V	12.8 V to 28 V	12.8 V to 20 V
Rated capacitance range	15 µF to 33 µF	10 µF to 100 µF	68 µF to 220 µF
Capacitance tolerance	±20 % (120 Hz / +20 °C)		
Leakage current	Please see the attached characteristics list		
Dissipation factor(tan δ)	Please see the attached characteristics list		
Surge voltage (V)	Rated voltage × 1.15		
Endurance	+125 °C 1000 h, category voltage applied		
	Capacitance change	Within ±20 % of the initial value	
	Dissipation factor(tan δ)	≤ 2 times of the initial limit	
	Leakage current	≤ 2 times of the initial limit	
Damp heat (Steady State)	+60 °C, 90 % to 95 % RH, 500 h, No-applied voltage		
	Capacitance change	Within +40 %, -20 % of the initial value	
	Dissipation factor(tan δ)	≤ 1.5 times of the initial limit	
	Leakage current	≤ 3 times of the initial limit	

Marking

〈 Laser marking (B size) 〉

〈 Laser marking (D size) 〉

〈 Other than the above 〉

R. voltage code (B size)		(D size)		Unit : V	
C	16	E	25	E ¹	25
D	20	D	20	1E	
				V	35

*1:Laser marking

R. capacitance code (B size)		Unit : µF	
E7	15	J7	22
N7	33		

Dimensions (not to scale)

Size code	L	W±0.2	H	S±0.2	W1±0.1
B2	3.5±0.2	2.8	1.9±0.1	0.8	2.2
D2	7.3±0.2	4.3	1.9±0.1	1.3	2.4
D3L	7.3±0.3	4.3	2.8±0.2	1.3	2.4

Unit : mm

* Externals of figure are the reference.

Characteristics list

Rated voltage (V)	Rated temperature (°C)	Category voltage (V)	Category temperature (°C)	Rated capacitance (μF)	Case size (mm)			Size code	Specifications				Standard		Floor life level	Re-flow soldering
					L	W	H		Ripple current (mA rms)	ESR ^{*2} (mΩ max.)	tan δ ^{*3}	LC ^{*4} (μA)	Part number	Min. packaging q'ty (pcs)		
16	105	12.8	125	33	3.5	2.8	1.9	B2	1000	90	0.10	158.4	16TDC33MB2	2000	3	A
	NEW 105	12.8	125	47	7.3	4.3	1.9	D2	1450	55	0.10	75.2	16TDC47MD2	3000		
	NEW 105	12.8	125		7.3	4.3	1.9		1250	70	0.10	75.2	16TDC47MBD2	3000		
	NEW 105	12.8	125	68	7.3	4.3	1.9	D2	1500	50	0.10	108.8	16TDC68MD2	3000		
	NEW 105	12.8	125	100	7.3	4.3	1.9		1800	50	0.10	160.0	16TDC100MD2	3000		
	105	12.8	125	150	7.3	4.3	2.8	D3L	1800	50	0.10	240.0	16TDC150MD3	2500		
105	12.8	125	220	7.3	4.3	2.8	1750		50	0.10	352.0	16TDC220MD3	2500			
20	105	16	125	22	3.5	2.8	1.9	B2	1000	90	0.10	132.0	20TDC22MB2	2000	3	A
	NEW 105	16	125	33	7.3	4.3	1.9	D2	1400	60	0.10	66.0	20TDC33MD2	3000		
	NEW 105	16	125	47	7.3	4.3	1.9		1450	55	0.10	94.0	20TDC47MD2	3000		
	105	16	125	100	7.3	4.3	2.8	D3L	1700	55	0.10	200.0	20TDC100MD3	2500	B	
25	105	20	125	15	3.5	2.8	1.9	B2	900	100	0.10	112.5	25TDC15MB	2000	3	A
	NEW 105	20	125		7.3	4.3	1.9	D2	1000	90	0.10	37.5	25TDC15MD2	3000		
	NEW 105	20	125	22	7.3	4.3	1.9		1400	60	0.10	55.0	25TDC22MD2	3000		
	NEW 105	20	125	33	7.3	4.3	1.9	D2	1400	60	0.10	82.5	25TDC33MD2	3000		
	105	20	125	68	7.3	4.3	2.8		D3L	1400	70	0.10	170.0	25TDC68MD3		
	105	20	125	100	7.3	4.3	2.8	1600		60	0.10	250.0	25TDC100MD3	2500		
35	NEW 105	28	125	10	7.3	4.3	1.9	D2	820	180	0.10	35.0	35TDC10MD2	3000	3	A
	NEW 105	28	125	15	7.3	4.3	1.9		900	150	0.10	52.5	35TDC15MD2	3000		
	NEW 105	28	125	22	7.3	4.3	1.9		900	150	0.10	77.0	35TDC22MD2	3000		

NRFND [Not recommended for new design]

16	105	12.8	125	33	3.5	2.8	1.9	B2	1000	90	0.10	158.4	16TDC33MYFB	2000	3	D
	105	12.8	125	100	7.3	4.3	1.9	D2	1800	50	0.10	160.0	16TDC100MYF	3000		
	105	12.8	125	150	7.3	4.3	2.8	D3L	1800	50	0.10	240.0	16TDC150MYF	2500		
20	105	12.8	125	22	3.5	2.8	1.9	B2	1000	90	0.10	132.0	20TDC22MYFB	2000	3	D
	105	12.8	125	100	7.3	4.3	2.8	D3L	1700	55	0.10	200.0	20TDC100MYF	2500		
25	105	12.8	125	15	3.5	2.8	1.9	B2	900	100	0.10	112.5	25TDC15MYFB	2000	3	D
	105	12.8	125	68	7.3	4.3	2.8	D3L	1400	70	0.10	170.0	25TDC68MYF	2500		

*1: Ripple current (100 kHz / +105 °C)

*2: ESR (100 kHz / +20 °C)

*3: tan δ (120 Hz / +20 °C)

*4: After 5 minutes

◆ Please refer to each page in this catalog for "Reflow conditions", "Taping specifications" and "Floor life level".

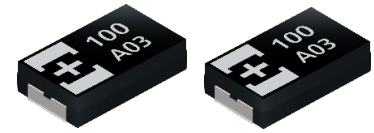

Conductive Polymer Tantalum Solid Capacitors

Surface Mount Type

TPC series

Features

- RoHS compliance, Halogen free

Specifications

Size code	D2	
Category temp. range	-55 °C to +105 °C	
Rated voltage range	10 V	
Category voltage range	10 V	
Rated capacitance range	68 μF to 100 μF	
Capacitance tolerance	±20 % (120 Hz / +20 °C)	
Leakage current	Please see the attached characteristics list	
Dissipation factor(tan δ)	Please see the attached characteristics list	
Surge voltage (V)	Rated voltage × 1.15	
Endurance	+105 °C 2000 h , rated voltage applied	
	Capacitance change	Within ±20 % of the initial value
	Dissipation factor(tan δ)	≤ 1.5 times of the initial limit
	Leakage current	Within the initial limit
Damp heat (Steady State)	+60 °C, 90 % to 95 % RH, 500 h, No-applied voltage	
	Capacitance change	Within +40 %, -20 % of the initial value
	Dissipation factor(tan δ)	≤ 1.5 times of the initial limit
	Leakage current	≤ 3 times of the initial limit

Marking

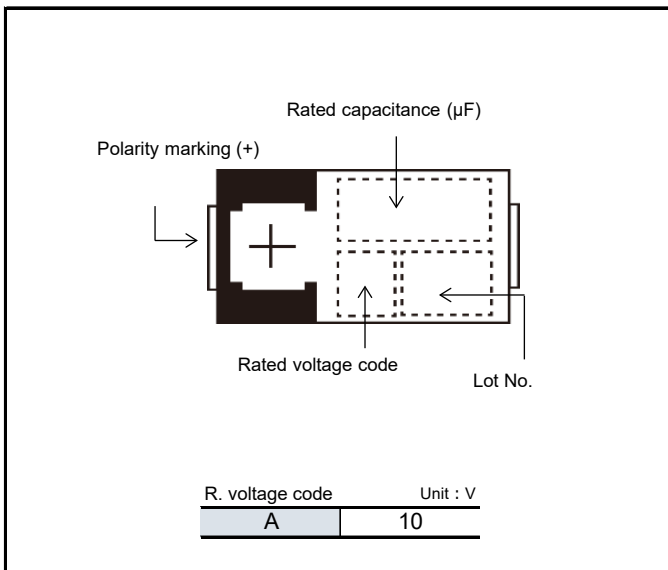

Dimensions (not to scale)

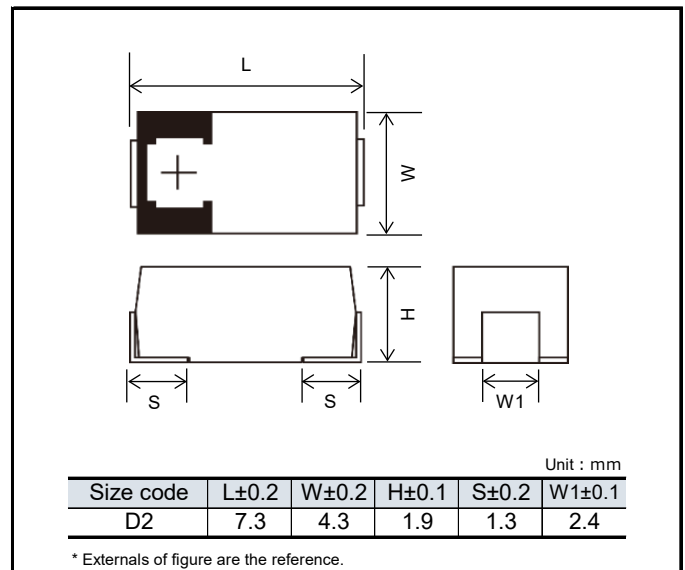

Characteristics list

Rated voltage (V)	Rated temperature (°C)	Category voltage (V)	Category temperature (°C)	Rated capacitance (µF)	Case size (mm)			Size code	Specifications				Standard		Floor life level	
					L	W	H		Ripple current (mA rms)	ESR ^{*2} (mΩ max.)	tan δ ^{*3}	LC ^{*4} (µA)	Part number	Min. packaging q'ty (pcs)	Reflow temp ≤260°C	Reflow temp ≤250°C
10	NRFND 105	10	105	68	7.3	4.3	1.9	D2	1700	45	0.10	68.0	10TPC68M	3000	3	2a
	105	10	105		7.3	4.3	1.9		1450	60	0.10	68.0	10TPC68MM	3000		
	105	10	105		7.3	4.3	1.9		1100	100	0.10	68.0	10TPC68ME	3000		
	105	10	105	100	7.3	4.3	1.9		1700	45	0.10	100.0	10TPC100M	3000		
	105	10	105		7.3	4.3	1.9		1600	50	0.10	100.0	10TPC100MT	3000		
	105	10	105		7.3	4.3	1.9		1500	55	0.10	100.0	10TPC100MG	3000		
	105	10	105		7.3	4.3	1.9									

*1: Ripple current (100 kHz / +45 °C)

*2: ESR (100 kHz / +20 °C)

*3: tan δ (120 Hz / +20 °C)

*4: After 5 minutes

NRFND Not recommended for new design

◆ Please refer to each page in this catalog for "Reflow conditions", "Taping specifications" and "Floor life level".

Catalog Deletion Models

The following table is a list of our items which have been deleted from our catalogs.

If you are using any of the following models on the deleted list,

please substitute them with the suggested alternative model as soon as possible.

Our company continue to supply them to customers who have already used them, for the time being.

Series	Size code	Models for deletion	Year of deletion	Alternative model	Series	Size code	Models for deletion	Year of deletion	Alternative model
TPB	B2	2R5TPB100M	2012	4TPE100MZB	TQC	C	16TQC22M	2011	25TQC22MYFD
		2R5TPB220MA	2009	2R5TPE220MZB			20TQC15M	2011	25TQC15MYFD
		4TPB100M	2009	4TPE100MZB			25TQC10M	2011	25TQC15MYFD
		8TPB47M	2009	10TPE47MAZB		D2	16TQC33M	2012	16TQC33MYFD
		6TPB47M	2009	6TPC47MB			16TQC47M	2012	16TQC47MYFD
		6TPB100MA	2009	6TPE100MAZB			16TQC68MY	2012	16TQC68MYF
		6TPB100MAV	2009	6TPE100MAZB			20TQC22M	2012	25TQC22MYFD
	D3L	2R5TPB330ML	2009	2R5TPE330M			20TQC22MYFD	2015	25TQC22MYFD
		4TPB220ML	2009	4TPE220M			20TQC47MY	2012	20TQC47MYF
		4TPB470ML	2009	4TPE470ML			25TQC15M	2012	25TQC15MYFD
		6TPB150ML	2009	6TPE150M		25TQC22M	2012	25TQC22MYFD	
		10TPB100ML	2010	10TPC100M		D3L	16TQC68M	2012	16TQC68MYF
	D3	4TPB220M	2008	4TPE220M			20TQC47M	2012	20TQC47MYF
		6TPB150M	2008	6TPE150M			25TQC33M	2012	25TQC33MYF
		10TPB100M	2008	10TPC100M		D3	16TQC100M	2012	16TQC100MYF
	D4	2R5TPB680M	2009	2R5TPE680MFL					
		2R5TPB1000M	2009	2R5TPE1000MF					
		4TPB470M	2009	4TPE470ML					
		4TPB680M	2009	6TPE680MI					
	TPC	B1	2R5TPC56M	2012		6TPB68M			
4TPC47M			2012	6TPC47MB					
6TPC33M			2012	6TPC47MB					
10TPC33MB			2013	16TQC33MYFB					
D2		2R5TPC330M	2009	2R5TPE330M					
		4TPC150M	2009	4TPE150MI					
		4TPC220M	2009	4TPE220M					
TPE	B2	2TPE330MIB	2011	ETPE330MFB					
		2TPE330MAFGB	2011	ETPE330MFB					
		2R5TPE150MZB	2011	2R5TPE220MZB					
		2R5TPE220MIB	2012	2R5TPE220MFGB					
		4TPE150MUB	2013	4TPE150MAZB					
	D2E	2R5TPE220MC	2012	2R5TPE220M9					
		2R5TPE220M7	2012	2R5TPE330M7					
		2R5TPE470M	2011	2R5TPE470MI					
		4TPE150M	2011	4TPE150MI					
	D3L	2R5TPE680ML	2012	2R5TPE680MFL					
		2R5TPE680MIL	2011	2R5TPE680MFL					
	D4	2R5TPE1000M	2011	2R5TPE1000MF					
		2R5TPE1000MI	2012	2R5TPE1000MF					
		4TPE680M	2011	6TPE680MI					
		4TPE680MI	2012	6TPE680MI					
4TPE680MF		2012	4TPF680MAH						
TPSF	B2S	11TPSF62MAIG	2012	—					
TH	D2	4THC220M	2013	4THE220M					
	D3L	2R5THB330ML	2010	—					
		10THB100ML	2010	—					
	D4	4THB680M	2013	—					

EOL Models

The following table is a list of the End-Of-Life (EOL) models.

Sales of these items will end as soon as we run out of its stock. We would like to express our appreciation for your business over the years with these products and we hope the new, alternative parts will continue to serve your needs. Thank you very much.

Series	Size code	Models for deletion	Year of deletion	Alternative model	Series	Size code	Models for deletion	Year of deletion	Alternative model
TPA	C	6TPA47M	2012/9	10TPB47M	TPE	C2	2R5TPE330MFC2	2012/9	2R5TPE330MF
		10TPA33M	2012/9	10TPB33M			2R5TPE330MIC2	2012/9	2R5TPE330MF
	4TPA220M	2012/9	4TPE220M	2R5TPE330MCC2			2012/9	2R5TPE330MC	
	6TPA150M	2012/9	6TPE150M	2R5TPE330M9C2			2012/9	2R5TPE330M9	
10TPA100M	2012/9	10TPC100M	4TPE220MFC2	2012/9			4TPE220MF		
B2	4TPB100MV	2012/9	4TPE100MZB	4TPE220MIC2			2012/9	4TPE220MI	
	4TPB150MA	2012/9	4TPE150MAZB	4TPE220MPC2			2012/9	4TPE220MI	
	8TPB33M	2012/9	10TPB33M	6TPE150MIC2			2012/9	6TPE150MI	
	2R5TPB220MC	2012/9	4TPE220MI	6TPE150MPC2		2012/9	6TPE150M		
	4TPB150MC	2012/9	6TPE150M	8TPE100MPC2		2012/9	10TPF150ML		
	4TPB220MC	2012/9	4TPE220MI	2R5TPE330MFC		2012/9	2R5TPE330MF		
	6TPB100MC	2012/9	6TPS150MUD	2R5TPE330MIC		2012/9	2R5TPE330MF		
	6TPB150MC	2012/9	6TPE150M	2R5TPE330MPC		2012/9	2R5TPE330MF		
TPB	C	8TPB82MC	2012/9	8TPE100MAZB		C3	4TPE220MIC	2012/9	4TPE220MI
		10TPB47MC	2012/9	10TPE68M			4TPE220MPC	2012/9	4TPE220MI
		10TPB68MC	2012/9	10TPC68M			6TPE150MPC	2012/9	6TPE150M
		10TPB220MC	2009/10	-	6TPE220MIC		2012/9	6TPE220MI	
		2R5TPB470ML	2012/9	2R5TPE470MI	6TPE220MPC		2012/9	6TPE220M	
	D3L	2R5TPB680ML	2012/9	2R5TPE680MFL	10TPE150MGC		2012/9	10TPE220ML	
		16TPB47ML	2003/6	16TQC47MYFD	10TPE180MGC		2012/9	10TPE220ML	
	D3	2R5TPB330M	2012/9	2R5TPE330MI	D15E		6TPE470MAZU	2024	6TPE470M
		16TPB47M	2003/6	16TQC47MYFD		D2E	2TPE330M6	2011	ETPSF270M6E
	2R5TPC82M	2012/9	-	2TPE330M7	2011		2R5TPE330M7		
4TPC56M	2012/9	-	2TPE330M9	2011	2R5TPE330M9				
4TPC100M	2012/9	6TPS150MUD	2TPE470M6	2011	2R5TPF470M6L				
TPC	C1	6TPC68M	2012/9	6TPS150MUD	D2E	2TPE470M7	2011	2R5TPE470M7	
		6TPC100MC	2012/9	6TPS150MUD		2TPE470M9	2011	2R5TPE470M9	
		8TPC33M	2012/9	16TQC33MYFB	D3L	6TPE330MAL	2021	6TPE330ML	
		6TPC47M	2024	10TPE47MAZB		D2E	2TPF470M6	2012/9	2R5TPF470M6L
		6TPC47MB	2024	10TPE47MAZB	2TPF220M6		2024	ETPSF270M6E	
		8TPC22M	2024	20TQC22MYFB	2TPF330M6	2024	ETPSF270M6E		
	8TPC150M	2024	10TPE150MPL	D3L	2R5TPF330M7L	2023	2R5TPF470M7L		
	12TPC10M	2024	35TQC10MYFB		4TPF470M5EL	2014	-		
	12TPC15M	2024	16TQC15M	TPF	6TPF330M5EL	2014	-		
	2R5TPC220M	2012/9	2R5TPE220MI		B1G	4TPG150M	2012/9	6TPS150MUD	
	16TPC33M	2003/6	16TQC33MYFD			6TPG68MG	2012/9	6TPS150MUD	
	6TPC100M	2024	6TPE100MW			2R5TPG220M	2021	ETPS220MUD	
	6TPC150M	2024	6TPE150M			6TPG100M	2021	6TPS150MUD	
	6TPC330MA	2024	6TPE330MAP		6TPG100MG	2021	6TPS150MUD		
	TPD	D4D	2R5TPD470M		2007/10	2R5TPF470ML	6TPG100MZGD	2021	6TPS150MUD
			2R5TPD470M5		2012/3	ETPF470M5H	8TPG47M	2021	10TPE47MAZB
2R5TPD470M6			2012/3		2R5TPF470M6L	10TPG33M	2011	16TQC33MYFB	
2R5TPD470M8			2007/10		2R5TPF470M7L	10TPG47M	2024	10TPE47MAZB	
2R5TPD680M			2007/10		2R5TPF680ML	12TPG33M	2024	16TQC33MYFB	
2R5TPD680M5			2012/3		2R5TPF680M6L	6TPG220MZG	2014	-	
2R5TPD680M6			2012/3		2R5TPF680M6L	2R5TPG220MUG	2021	ETPS220MUD	
2R5TPD680M8			2007/10		2R5TPF680M7L	4TPG220M	2021	4TPS220MUD	
2R5TPD1000M			2012/3		ETPF1000M6H	6TPG150M	2021	6TPS150MUD	
2R5TPD1000M8			2012/3		ETPF1000M6H	6TPG150MZG	2021	6TPS150MUD	
2R5TPD1000M6			2012/3	ETPF1000M6H	B15G	2R5TPL220MC	2012/9	-	
2R5TPD1000M5			2012/3	ETPF1000M5H		D2T	2R5TPL330M7	2011/7	-
4TPD330M			2007/10	4TPF330ML		D12T	All models	2013	-
4TPD470M			2007/10	4TPF470ML			D15T	All models	2013
4TPD680M			2012/3	4TPF680MAH	All models			2013	-
6TPD220M			2007/10	6TPF220ML	TPLF	D2T		2TPLF470M7	2012/9
6TPD330M	2007/10	6TPF330M9L	D2T	2TPLF560M6		2011/7	-		
6TPD470M	2012/3	6TPF470MAH	TPSF	B2S	2TPSF270MC	2012/9	2TPSF270M9G		
10TPD150M	2007/10	10TPF150ML		B1S	2TPSF270M9	2012/9	2TPSF270M9G		
TPE	B2	2R5TPE220MPB	2012/9	2R5TPE220MLB	TR	ETPSF200M9ED	2014	-	
		2R5TPE220MDGB	2013	2R5TPE220MFBG	APA	TR series	-	TA series	
		2TPE330MFB	2021	ETPE330MFB	APB	APA series	2006/4	-	
		2TPE330MAFB	2021	ETPE330MFB	APD	APB series	2006/4	-	
TH	D2	2TPE330MADGB	2021	ETPE330M9GB	APC	D1	APC series	2009/6	-
		6THC150M	2024	6TCE150M	APD	D2	APD series	2009/6	-
	D4	2R5THB470ML	2012/9	6TCE470M	TPU	S08	2R5TPU22M	2012/9	-
		2R5THB680M	2012/9	-			4TPU15M	2012/9	-
2R5THB1000M	2012/9	-	6TPU10M	2012/9			-		
2R5THD680M	2012/3	2R5TPF680M6L	2R5TPU22MSI	2011			-		
4THD470M	2012/9	-	2R5TPU47MSI	2018		-			
6THD330M	2012/3	6TPF330M9L	ETPU100MSI	2018		-			
TQC	B15	35TQC2R7MYF	2016	-		4TPU15MSI	2011	-	
		16TQC10M	2023	35TQC10MYFB		4TPU33MSI	2011	-	
		20TQC8R2M	2023	35TQC10MYFB		4TPU68MSI	2018	-	
		25TQC5R6M	2023	35TQC10MYFB		6TPU10MSI	2018	-	
	D12	35TQC3R9MYF	2023	35TQC10MYFB		6TPU22MSI	2018	-	
		16TQC33MYFS	2024	16TQC33MYFD		6TPU47MSI	2018	-	
		16TQC47MV	2023	16TQC47MYFD		10TPU4R7MSI	2018	-	
		25TQC15MV	2023	25TQC15MYFD		2R5TPU47MSK	2012/9	-	
D2	25TQC22MV	2023	25TQC22MYFD	2R5TPU68MSK		2013	-		
	35TQC10M	2024	35TQC10MYF	4TPU33MSK		2012/9	-		
	ETPH100MHA	2018	-	4TPU47MSK	2013	-			
	4TPH68MHA	2018	-	6TPU22MSK	2012/9	-			
TPH	A09	6TPH47MHA	2018	-	6TPU33MSK	2013	-		
		6TPH100MAEA	2018	-	2R5TPU100MAI	2011	-		
		ATPH33MAHA	2018	-	4TPU68MAI	2011	-		
	A14	ETPH220MABC	2018	-	6TPU47MAI	2011	-		
		ETPH220MAZC	2013	-	10TPU33MAI	2011	-		
		4TPH150MABC	2018	-	4TPU68MBI	2012/9	-		
TQS	B1S	6TPH100MABC	2018	-	6TPU47MBI	2012/9	-		
		16TQS33MBD	2020	-	6TPU150MBI	2018	-		
		25TQS10MED	2020	-	8TPU33MBI	2012/9	-		
		35TQS6R8MHD	2020	-	ETLE330MCGB	2024/4	ETPE330M9GB		
TA	D2E	10TAE68M	2023	10TVE68M	6TLE100MZB	2024/4	6TPE100MZB		

Conductive Polymer Aluminum Solid Capacitors

OS-CON™



INDEX

Application Guidelines (OS-CON)	P90
Line-up / Diagram	P93
Voltage - Capacitance table	P99
Explanation of part numbers	P104
Mounting / Packing specifications	P105
Each series	P108

Applications

Main market

Desktop computer



Audio / Visual

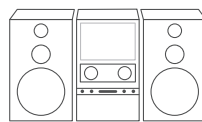

Server



Communications infrastructure



Industrial equipment

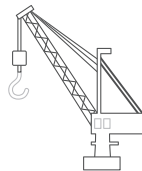

Industrial robot

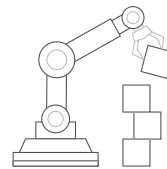

Home appliance



Matters to Be Observed When Using This Product (Conductive Polymer Aluminum Solid Capacitors / OS-CON)

Use environments and cleaning conditions

- This product (capacitor) is intended for standard general-purpose use in electronic equipment, and is not designed for use in the specific environments described below. Using the product in such specific environments or service conditions, therefore, may affect the performance of the product.

Please check with us about the performance and reliability of the product first before using the product.

- (1) Used in liquid, such as water, oil, chemicals, and organic solvents.
- (2) Used in a place exposed to direct sunlight, an outdoor place with no shielding, or a dusty place.
- (3) Used in a wet place (dew concentration on a resistor, water leakage, etc.), a place exposed to sea breeze, or a place filled with a corrosive gas, such as Cl₂, H₂S, NH₃, SO₂, or NO_x.
- (4) Used in an environment where static electricity and electromagnetic waves are strong.
- (5) The product is located close to a heating component or a flammable material, such as a vinyl cable, is placed near the product.
- (6) The product is used sealed with a resin, etc.
- (7) Solder flux of the soldered product is cleansed with a solvent, water, and a water-soluble cleaner.
(Be careful with water soluble solder flux.)
- (8) Used in an environment where an acidic or alkali atmosphere is present.
- (9) Used in an environment where excessive vibration or impact is applied to the product.
- (10) Used under a low atmospheric pressure condition or depressurized condition.

- Cleaning can be performed with cleaning agents, including higher-grade alcohol-based cleaning solutions such as Pine Alpha ST-100S, Cleanthru 750H, 750L, 710M, 750K, Techno Care FRW14-17, CFC substitutes such as AK-225AES, and IPA. Please confirm the following precautions before cleaning.

- (1) Use an immersion, ultrasonic wave, or other cleaning method, and the cleaning time should not exceed 2 minutes.
- (2) The temperature of the cleaning solution should be less than or equal to 60 °C.
- (3) Control contamination of cleaning agents (conductivity, pH, specific gravity, water content, etc.).
- (4) After cleaning, do not store the product in the atmosphere of the cleaning solution or in an airtight container.
- (5) When drying the circuit board or this product, use hot air below the upper limit temperature of their category.
- (6) Please be mindful that rubbing the printed surface of this product after cleaning may erase the markings depending on the cleaning agent used.
- (7) Please contact us separately for details on cleaning agents, cleaning methods, etc., and for cleaning solutions other than those listed above.

- Fixing agents and coating agents

- (1) Select appropriate materials for the outer packaging and sealing materials of this product. Do not use acetone, especially in fixing agents, coating agents, or diluents.
- (2) When using a fixing agent or coating agent, ensure that no flux residue or contamination remains between the circuit board and the sealing area of this product.
- (3) Allow cleaning agents, etc. to dry before using fixing agents or coating agents.
- (4) Please contact us for thermal curing conditions for fixing agents or coating agents.

- When the capacitor is used in a circuit where an impact voltage is applied or a high voltage is applied in a short period (transient phenomenon) or a high pulse voltage is applied, make sure to use the capacitor at a voltage equal to or lower than its rated voltage.

Response to anomalies and handling conditions

- The main failure mode is a short-circuit mode caused mainly by thermal stress, electrical stress, and mechanical stress due to soldering and operating temperature environments. To prevent the occurrence of short circuits, the following measures should be adequately taken to ensure safety.
 - (1) If odorous gases are generated, then turn off the main power of the set equipment and stop using it.
In this case, keep your face and hands away from the equipment.
 - (2) Depending on conditions, it may take several seconds to several minutes before odorous gases are generated.
When using a protection circuit, design it so that it operates during this period.
 - (3) If odorous gases get into your eyes or are inhaled, immediately wash your eyes with water or gargle.
 - (4) Do not lick the electrolyte of the product. If the electrolyte gets on your skin, then wash it off with soap.
 - (5) When a current value after the short of the product is extremely large, the shorted capacitor may spark out, which, in the worst scenario, may result in ignition. Ensure the safety of the circuit by, for example, giving it a redundant circuit structure or providing it with a protective circuit.

Reliability and product life

The failure rate of the capacitor is specified based on 0.5%/1000 h (reliability level 60%), a failure rate conforming to JIS C 5003 (failure rate level). This indicates that the possibility of occurrence of a failure is by no means zero. One of the failure modes is a wear out failure. This happens when the period of guaranteeing the durability and high-temperature/high-humidity resistance of the capacitor is over, changes in the electrical characteristics of the capacitor (product) get larger and its electrolyte gradually deteriorates into an insulating material to create an open mode. Another failure mode is a random failure in which a short mode results mainly because of thermal, electrical, or mechanical stress, etc.

Circuit design and circuit board design

- Due to reasons such as increased leakage currents, do not use this product in high impedance circuits, coupling circuits, time constant circuits, and circuits that are significantly affected by leakage currents.
- During circuit design, be mindful that the electrical characteristics of this product, such as capacitance and ESR, may fluctuate within the specified ranges even under conditions that meet the rated electrical and mechanical performance.
- Leakage currents may increase due to mechanical and thermal stress (soldering, high-temperature no-load test, etc.). However, when the voltage (lower than or equal to the category voltage and upper limit temperature) is applied, leakage currents gradually decrease due to the self-recovery function.
- If an excessive rush current flows due to rapid charging and discharging, then it may lead to short circuits and increased leakage currents. Therefore, apply a protection circuit to this product if the rush current value flowing through it is as follows.
 - (1) When a rush current of 10 A or more flows through a product whose tenfold allowable ripple current is less than 10 A.
 - (2) With regard to a product whose tenfold allowable ripple current is 10 A or more, when a rush current exceeding the tenfold value flows through the product.
- The resin on the surface of the case does not guarantee insulation. In addition, there is an indefinite resistance between the case and the cathode terminal, and they are not insulated. Therefore, completely isolate the case from the cathode terminal, anode terminal, and circuit pattern.

Mounting and storage conditions

- Soldering with a soldering iron
 - (1) Since the lead wire pitch dimension of the radial lead type capacitor and the printed circuit board hole pitch dimension do not match, when processing the lead wires, do not apply stress to the body before soldering.
 - (2) When soldering, do not apply excessive stress to the body of this product.
 - (3) Once the product has been soldered, when using a soldering iron to remove it, remove it after the solder has completely melted so as not to apply stress to the electrode terminals of the product.
 - (4) Do not allow the tip of the soldering iron to touch the body of this product.

■ Flow soldering

- (1) Do not apply flow soldering to the surface mount type model of this product.
- (2) Do not solder this product by immersing its body in molten solder.
- (3) Solder only on the opposite side of the circuit board surface where this product is mounted.
- (4) Do not allow flux to adhere to parts other than the electrode terminals.
- (5) Do not allow other parts to fall over and come into contact with this product during soldering.

■ Reflow soldering

- (1) Do not apply reflow soldering to the radial lead type model of this product.
- (2) Please contact us separately for soldering conditions for using the VPS method.

■ Handling after soldering

Observe the following precautions to avoid applying excessive stress on this product.

- (1) Do not tilt, knock over, or twist this product.
- (2) Do not move the circuit board by grabbing this product.
- (3) Do not hit this product with objects.
- (4) When stacking circuit boards, do not allow circuit boards or other parts to come in contact with this product.

- It is recommended that all components in the bag be used up by opening the bag immediately before use. However, if the remaining components are to be stored after opening the bag, please use them up within the following specified period* to maintain good solderability.

* The surface mount type does not comply with the JEDEC J-STD-020 specification.

- | | |
|---------------------------------------|--|
| (1) Surface mount type | : Within 24 months after shipment (before opening) and within 30 days after opening (packaged with carrier tape) |
| (2) Radial lead type (bagged product) | : Within 30 months after shipment (before opening) and within 7 days after opening |
| (3) Radial lead type (taped product) | : Within 24 months after shipment (before opening) and within 7 days after opening |

Reference information

Intellectual property

Panasonic Group provides customers with safe products and services. We are also making great efforts to protect our intellectual property rights for Panasonic Group products. Typical patents related to this product are as follows.

* No target

Line up

SMD type

Series	Features	Small size/Low profile	Large cap.	Low ESR	High voltage	Long life/High reliability	Category tem. range (°C)	Rated voltage range (V)	ESR (mΩ)	Rated capacitance range (μF)	Size code	Size (mm)	
												øD	L
SVT	Low ESR Large capacitance 125 °C 2000 h		●	●	●	●	-55 to 125	2.5 to 16	15 to 24	100 to 820	C65	6.3	6.4
							-55 to 125	2.5 to 50	20 to 35	18 to 680	E7	8.0	6.9
							-55 to 125	16	18	560	E10	8.0	10.0
							-55 to 125	2.5 to 50	10 to 25	39 to 1500	E12	8.0	11.9
							-55 to 125	16	16	1000	F10	10.0	10.0
							-55 to 125	2.5 to 50	12 to 20	68 to 2700	F12	10.0	12.6
SVPT	Low ESR Large capacitance 105 °C 20000 h		●	●	●	●	-55 to 105	2.5 to 16	15 to 24	100 to 820	C65	6.3	6.4
							-55 to 105	2.5 to 50	20 to 35	18 to 680	E7	8.0	6.9
							-55 to 105	16	18	560	E10	8.0	10.0
							-55 to 105	2.5 to 50	10 to 25	39 to 1500	E12	8.0	11.9
							-55 to 105	16	16	1000	F10	10.0	10.0
							-55 to 105	2.5 to 50	12 to 20	68 to 2700	F12	10.0	12.6
SVF	High voltage Large capacitance 125 °C 1000 h		●		●	●	-55 to 125	16 to 25	27 to 40	27 to 82	B6	5.0	5.9
							-55 to 125	16 to 50	22 to 40	10 to 180	C6	6.3	5.9
							-55 to 125	16 to 50	22 to 35	18 to 270	E7	8.0	6.9
							-55 to 125	16 to 50	14 to 25	39 to 560	E12	8.0	11.9
							-55 to 125	16	16	1000	F10	10.0	10.0
							-55 to 125	16 to 50	12 to 20	68 to 1000	F12	10.0	12.6
SVPK	High voltage Large capacitance 125 °C 1000 h		●		●	●	-55 to 125	16 to 50	27 to 80	10 to 100	B6	5.0	5.9
							-55 to 125	16 to 50	22 to 35	22 to 220	C6	6.3	5.9
							-55 to 125	16 to 50	22 to 35	33 to 330	E7	8.0	6.9
							-55 to 125	16 to 50	14 to 25	68 to 680	E12	8.0	11.9
							-55 to 125	16 to 50	12 to 20	120 to 1200	F12	10.0	12.6
UPDATE SXV	Super high voltage 125 °C 1000 h				●	●	-55 to 125	63 to 100	60	6.8 to 18	E7	8.0	6.9
							-55 to 125	63 to 100	50 to 60	15 to 39	F8	10.0	7.9
							-55 to 125	63 to 100	25 to 40	15 to 82	E12	8.0	11.9
							-55 to 125	63 to 100	25 to 30	18 to 150	F12	10.0	12.6
SVPG ^{*1}	Low ESR High ripple current 105 °C 5000 h			●	●		-55 to 105	16 to 25	25 to 30	15 to 47	B45	5.0	4.4
							-55 to 105	16	15	100	B6	5.0	5.9
							-55 to 105	16 to 25	14 to 18	82 to 220	C6	6.3	5.9
							-55 to 105	16 to 25	10 to 14	120 to 270	C8	6.3	7.9
							-55 to 105	16 to 25	8 to 13	150 to 270	C10	6.3	9.9
							-55 to 105	16	6.5	330	C10L	6.3	10.4
							-55 to 105	16 to 25	16 to 18	120 to 330	E7	8.0	6.9
							-55 to 105	16	10	560	E10	8.0	10.0
							-55 to 105	16 to 25	8 to 12	270 to 680	E12	8.0	11.9
							-55 to 105	16	9	820	F10	10.0	10.0
SVPF	High voltage Large capacitance 105 °C 5000 h		●		●	●	-55 to 105	16 to 25	27 to 40	27 to 82	B6	5.0	5.9
							-55 to 105	16 to 50	22 to 40	10 to 180	C6	6.3	5.9
							-55 to 105	16 to 50	22 to 35	18 to 270	E7	8.0	6.9
							-55 to 105	16	18	560	E10	8.0	10.0
							-55 to 105	16 to 50	14 to 25	39 to 560	E12	8.0	11.9
							-55 to 105	16	16	1000	F10	10.0	10.0
							-55 to 105	16 to 50	12 to 20	68 to 1000	F12	10.0	12.6

*1: Some part numbers are not a recommended product

Line up

SMD type

Series	Features	Small size/Low profile	Large cap.	Low ESR	High voltage	Long life/High reliability	Category tem. range (°C)	Rated voltage range (V)	ESR (mΩ)	Rated capacitance range (μF)	Size code	Size (mm)	
												øD	L
SVPA ^{*1}	Low ESR High ripple current			●			-55 to 105	2.5 to 20	30 to 40	10 to 82	B6	5.0	5.9
							-55 to 105	2.5 to 20	20 to 35	22 to 180	C6	6.3	5.9
							-55 to 105	2.5 to 20	20 to 33	47 to 330	E7	8.0	6.9
							-55 to 105	2.5 to 16	19 to 29	180 to 820	F8	10.0	7.9
SVPC	Low ESR Large capacitance		●	●			-55 to 105	2.5 to 16	19 to 35	39 to 180	B6	5.0	5.9
							-55 to 105	2.5 to 16	15 to 30	68 to 560	C6	6.3	5.9
							-55 to 105	2.5 to 16	19 to 27	120 to 680	E7	8.0	6.9
							-55 to 105	2.5 to 16	9 to 16	270 to 1500	E12	8.0	11.9
SVPD ^{*1}	Guaranteed at 125°C High voltage 85 °C 85 % RH				●	●	-55 to 125	10 to 25	45 to 65	10 to 56	C6	6.3	5.9
							-55 to 125	16 to 35	40 to 70	8.2 to 82	E7	8.0	6.9
							-55 to 125	25 to 35	45 to 60	18 to 39	F8	10.0	7.9
							-55 to 125	25 to 35	30 to 50	22 to 47	E12	8.0	11.9
SVPE	Low ESR Large capacitance		●	●			-55 to 105	2.5 to 6.3	10 to 15	150 to 390	B6	5.0	5.9
							-55 to 105	2.5 to 10	10 to 20	220 to 820	C6	6.3	5.9
							-55 to 105	2.0 to 16	8 to 11	180 to 1200	C10	6.3	9.9
							-55 to 105	16	10	470	F12	10.0	12.6
SVPS ^{*1}	Long life				●		-55 to 105	4.0 to 10	200 to 220	10 to 33	A5	4.0	5.4
							-55 to 105	4.0 to 16	30 to 90	22 to 68	B6	5.0	5.9
							-55 to 105	4.0 to 20	22 to 60	22 to 150	C6	6.3	5.9
							-55 to 105	4.0 to 25	22 to 60	10 to 270	E7	8.0	6.9
							-55 to 105	4.0 to 16	20 to 35	100 to 680	F8	10.0	7.9
SVQP ^{*1}	Guaranteed at 125 °C				●		-55 to 105	4.0 to 20	40 to 60	22 to 150	C6	6.3	5.9
							-55 to 105	6.3 to 20	35 to 45	47 to 220	E7	8.0	6.9
SVP ^{*1}	Standard						-55 to 105	4.0 to 16	200 to 260	3.3 to 33	A5	4.0	5.4
							-55 to 105	4.0 to 20	60 to 120	10 to 68	B6	5.0	5.9
							-55 to 105	2.5 to 20	23 to 60	22 to 220	C6	6.3	5.9
							-55 to 105	4.0 to 20	35 to 45	33 to 330	E7	8.0	6.9
							-55 to 105	4.0 to 20	25 to 40	56 to 680	F8	10.0	7.9
							-55 to 105	2.5 to 20	13 to 24	100 to 680	E12	8.0	11.9
-55 to 105	2.5 to 20	12 to 20	150 to 1500	F12	10.0	12.6							

*1: Some part numbers are not a recommended product

Line up

Radial lead type (Not recommended for new design)

Series	Features	Small size/Low profile	Large cap.	Low ESR	High voltage	Long life/High reliability	Category tem. range (°C)	Rated voltage range (V)	ESR (mΩ)	Rated capacitance range (μF)	Size code	Size (mm)	
												øD	L
SEF	High voltage Large capacitance 125 °C 1000 h		●		●	●	-55 to 125	16 to 35	22 to 35	22 to 180	C6	6.3	5.9
							-55 to 125	16 to 35	22 to 30	39 to 270	E7	8.0	6.9
							-55 to 125	16 to 35	14 to 20	82 to 560	E12	8.0	11.9
							-55 to 125	16 to 5	12 to 18	120 to 1000	F13	8.0	12.9
SEK	High voltage Large capacitance 125 °C 1000 h		●		●	●	-55 to 125	25 to 50	25 to 35	22 to 82	C6	6.3	5.9
							-55 to 125	25 to 50	24 to 35	33 to 120	E7	8.0	6.9
							-55 to 125	25 to 50	16 to 25	68 to 270	E12	8.0	11.9
							-55 to 125	25 to 50	14 to 20	120 to 470	F13	8.0	12.9
SEPG	Low ESR High ripple current 105 °C 5000 h			●	●		-55 to 105	16	12	150	B9	5.0	8.9
							-55 to 105	16	10	270	C9	10.0	8.9
							-55 to 105	16	8	270	C10	6.3	9.9
							-55 to 105	16	8	470	E9	8.0	8.9
SXE	Super high voltage 125 °C 1000 h				●	●	-55 to 125	63 to 100	60	6.8 to 18	E7	8.0	6.9
							-55 to 125	63 to 100	50 to 60	15 to 39	F8	8.0	7.9
							-55 to 125	63 to 100	25 to 40	15 to 68	E12	8.0	11.9
							-55 to 125	63 to 100	25 to 30	18 to 120	F13	8.0	12.9
SEPF	Small size Low profile High voltage Large capacitance 105 °C 5000 h	●	●		●	●	-55 to 105	16 to 32	30 to 35	22 to 150	C55	6.3	5.4
							-55 to 105	16 to 35	22 to 35	22 to 180	C6	6.3	5.9
							-55 to 105	16 to 35	22 to 30	39 to 270	E7	8.0	6.9
							-55 to 105	16 to 35	14 to 20	82 to 560	E12	8.0	11.9
							-55 to 105	16 to 35	12 to 18	120 to 1000	F13	10.0	12.9
SEPC	Super low ESR Large capacitance Small size Low profile 105 °C 5000 h	●	●	●	●	●	-55 to 105	2.5	7	100 to 560	B9	5.0	8.9
							-55 to 105	6.3	18	220	C55	6.3	5.4
							-55 to 105	2.5 to 16	10 to 24	100 to 560	C6	6.3	5.9
							-55 to 105	2.5 to 16	7 to 10	100 to 820	C9	6.3	8.9
							-55 to 105	2.5 to 16	8 to 22	150 to 1000	E7	8.0	6.9
							-55 to 105	2.5 to 16	5 to 10	180 to 1000	E9	8.0	8.9
							-55 to 105	16	11 to 16	180 to 270	E12	8.0	11.9
							-55 to 105	2.5 to 6.3	7 to 8	470 to 820	E13	8.0	12.9
SEQP	105 °C 5000 h Guaranteed at 125 °C Rated 32 V max.				●	●	-55 to 125	4.0 to 20	40 to 60	22 to 150	C6	6.3	5.9
							-55 to 125	4.0 to 32	35 to 100	6.8 to 330	E7	8.0	6.9
							-55 to 125	4.0 to 32	25 to 80	15 to 680	F8	10.0	7.9
							-55 to 125	4.0 to 32	13 to 50	18 to 560	E12	8.0	11.9
							-55 to 125	4.0 to 20	12 to 20	150 to 1200	F13	10.0	12.9
SEP	Standard				●	●	-55 to 105	4.0 to 20	40 to 60	22 to 150	C6	6.3	5.9
							-55 to 105	4.0 to 20	35 to 45	33 to 330	E7	8.0	6.9
							-55 to 105	4.0 to 20	25 to 40	56 to 680	F8	10.0	7.9
							-55 to 105	2.5 to 20	13 to 24	100 to 680	E12	8.0	11.9
							-55 to 105	2.5 to 20	12 to 20	150 to 1500	F12	10.0	12.9

Series flow chart

● SMD type

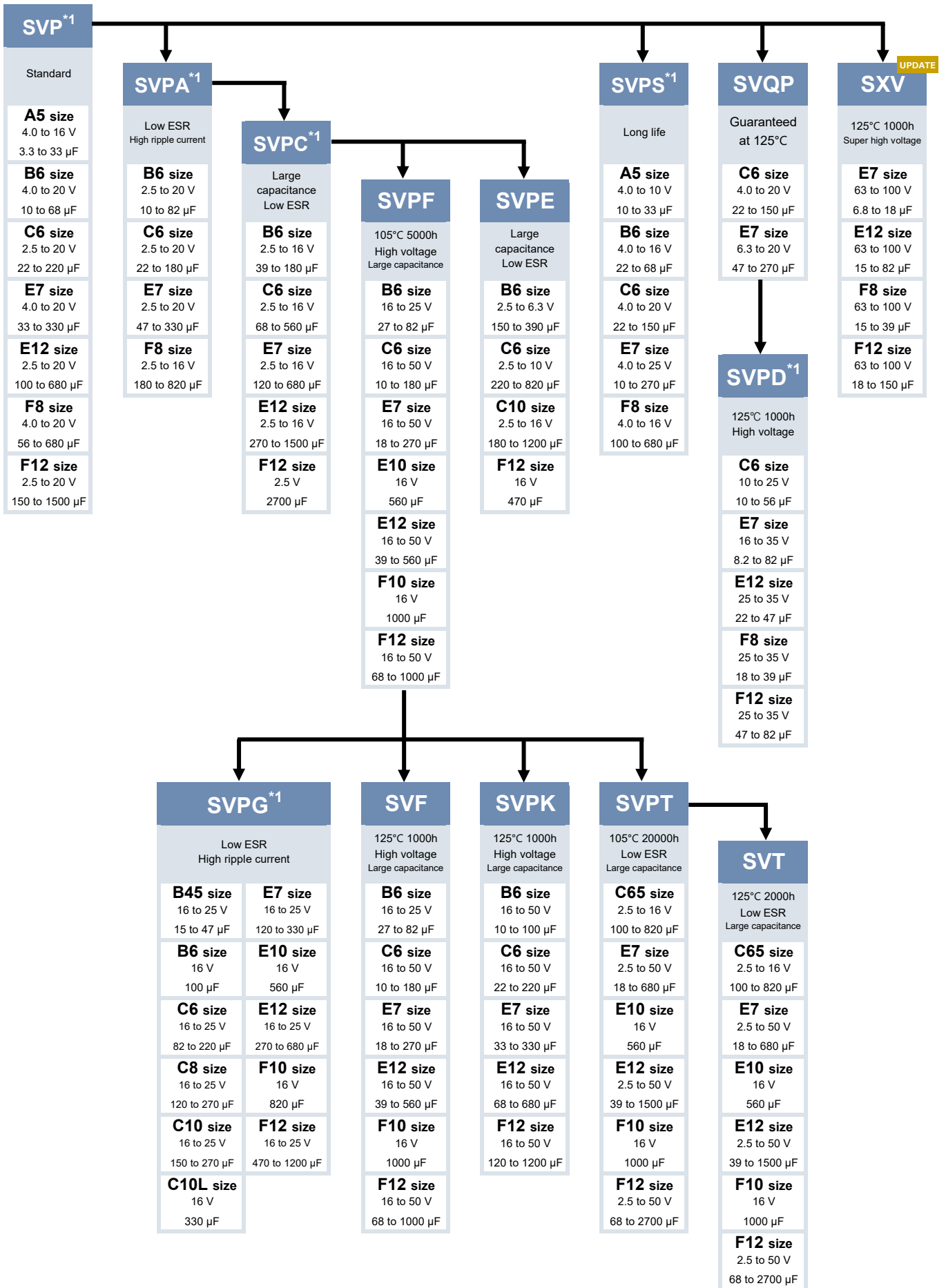

*1: Some part numbers are not a recommended product

Series flow chart

● Radial lead type (Not recommended for new design)

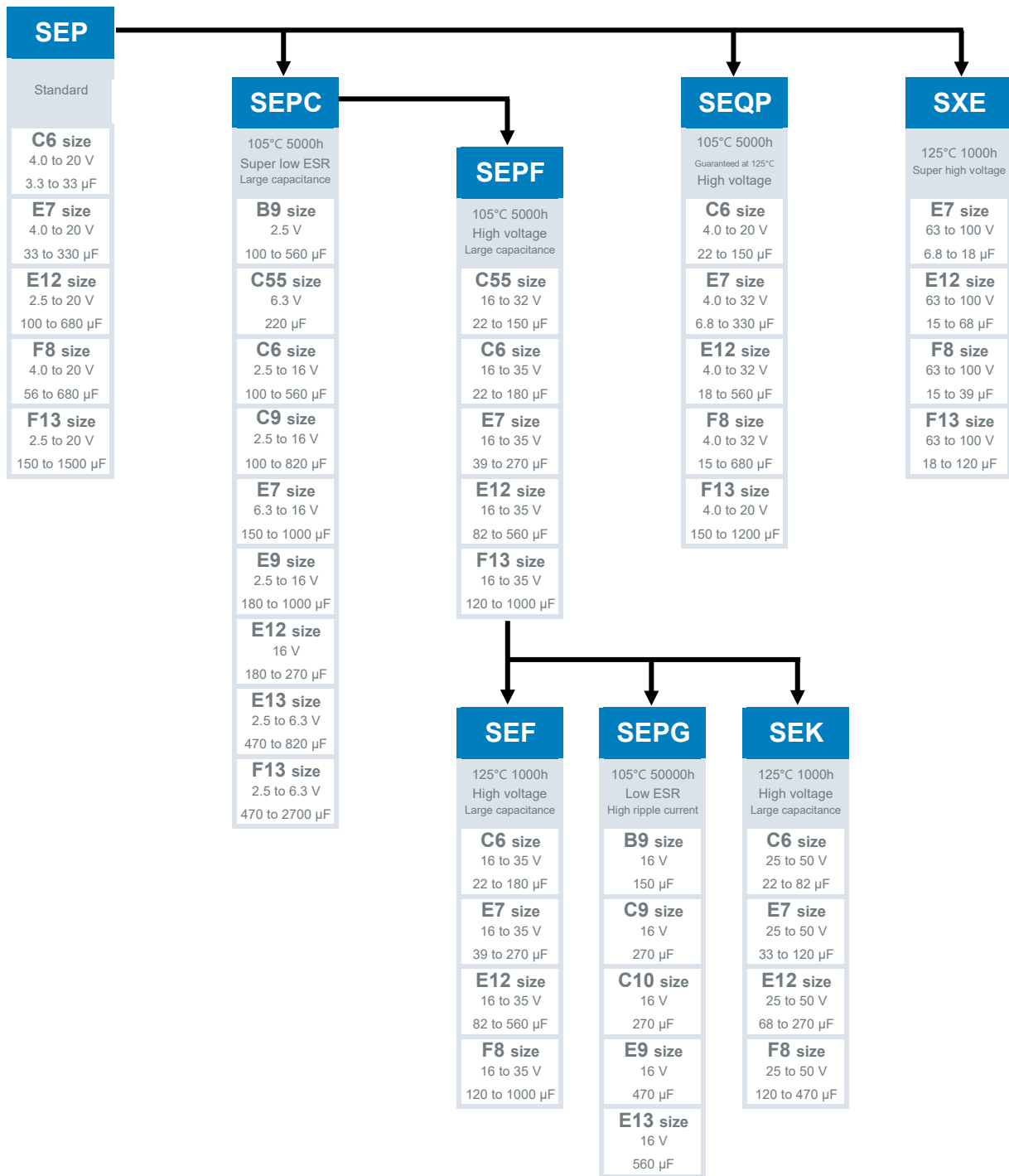

Voltage - Capacitance table (SMD type) (Vol. : 2.0 to 16 V / Cap. : 6.8 to 56 μ F)

Series [Size]
(ESR m Ω)

V \ μ F	6.8	10	12	15	18	22	27	33	39	47	56
2.0											
2.5											
4.0											
6.3										SVPA [B6] (30)	
										SVPS [B6] (30)	
										SVP [B6] (70)	
10										SVP [C6] (50)	SVPD [C6] (45)
											SVQP [C6] (45)
											SVP [C6] (45)
16							SVP [B6] (120)		SVPA [C6] (35,24)	SVPG [B45] (25)	SVP [E7] (45)
									SVPC [B6] (35,27)		
									SVPS [C6] (24)		
									SVQP [C6] (50)		
									SVP [C6] (50)		

Size list ϕ x L (mm)

A5	4.0x5.4	B45	5.0x4.4	C6	6.3x5.9	C8	6.3x7.9	E7	8.0x6.9	F8	10.0x7.9
		B6	5.0x5.9	C65	6.3x6.4	C10	6.3x9.9	E10	8.0x10.0	F10	10.0x10.0
						C10L	6.3x10.4	E12	8.0x11.9	F12	10.0x12.6

Voltage - Capacitance table (SMD type) (Vol. : 2.0 to 16 V / Cap. : 68 to 470 μF)

Series [Size]
(ESR mΩ)

V \ μF	68	82	100	120	150	180	220	270	330	390	470
2.0											
2.5						SVPC [B6] (30,24,19)	SVP [C6] (23)	SVPE [B6] (10)	SVPE [B6] (15,10)	SVPC [C6] (25,15)	
										SVPE [B6] (10)	
										SVPE [C6] (10)	
4.0	SVPS [B6] (30)				SVPC [B6] (30,23,20)			SVPA [E7] (22)	SVPC [C6] (27,21,15)		
	SVP [B6] (60)				SVPS [C6] (22)				SVP [E7] (35)		
					SVQP [C6] (40)						
					SVP [C6] (40)						
6.3		SVP [C6] (45)	SVPC [B6] (30,25)	SVPA [C6] (22)	SVPE [B6] (12)		SVPA [E7] (22)		SVT [C65] (15)	SVT [E7] (22)	SVPA [F8] (20)
			SVQP [C6] (40)	SVPC [B6] (21)			SVPC [C6] (27,15)		SVPT [C65] (15)	SVPT [E7] (22)	SVPS [F8] (20)
			SVP [C6] (40)	SVPS [C6] (22)			SVPE [B6] (15)		SVPC [C6] (17)	SVPC [E7] (22)	SVP [E12] (15)
				SVP [C6] (17)			SVPE [C6] (10)		SVP [F8] (25)		SVP [F8] (25)
							SVPE [E7] (22)				
							SVQP [E7] (35)				
10	SVPA [C6] (30)			SVPC [C6] (27,22)	SVPA [E7] (30)		SVPE [C6] (20)	SVPC [E7] (22)	SVPA [F8] (24)		
	SVPC [B6] (30,23)			SVQP [E7] (35)	SVPS [E7] (30)			SVP [F8] (25)	SVPC [E7] (19)		
	SVPS [C6] (30)			SVP [E7] (35)	SVPS [F8] (30)				SVPS [F8] (24)		
					SVQP [E7] (35)				SVP [E12] (17)		
					SVP [E7] (35)				SVP [F8] (25)		
16	SVPC [C6] (30,25)	SVPA [E7] (30)	SVT [C65] (24)	SVPC [E7] (27)	SVPC [E7] (22)	SVPA [F8] (29)	SVPG [C6] (14)	SVT [E7] (22)	SVPG [C10L] (6,5)		SVPE [F12] (10)
		SVPD [E7] (40)	SVPT [C65] (24)		SVP [F8] (30)	SVPE [C10] (11)	SVPK [C6] (22)	SVPT [E7] (22)	SVPG [E7] (16)		
		SVPF [B6] (24)	SVPC [C6] (24)			SVPF [C6] (22)		SVPC [E12] (16)	SVPK [E7] (22)		
		SVPS [E7] (30)	SVPG [B6] (15)			SVPS [F8] (29)		SVPF [E7] (22)	SVP [F12] (16)		
		SVQP [E7] (40)	SVPK [B6] (27)			SVP [F8] (30)		SVPG [C8] (10)			
		SVP [E7] (40)	SVPS [F8] (35)			SVP [E12] (20)		SVPG [C10] (8)			
		SVF [B6] (25)	SVP [F8] (35)			SVF [C6] (22)		SVF [E7] (22)			

Size list ø x L (mm)

A5	4.0x5.4	B45	5.0x4.4	C6	6.3x5.9	C8	6.3x7.9	E7	8.0x6.9	F8	10.0x7.9
		B6	5.0x5.9	C65	6.3x6.4	C10	6.3x9.9	E10	8.0x10.0	F10	10.0x10.0
						C10L	6.3x10.4	E12	8.0x11.9	F12	10.0x12.6

Voltage - Capacitance table (SMD type) (Vol. : 2.0 to 16 V / Cap. : 560 to 2700 μ F)

Series [Size]
(ESR m Ω)

V / μ F	560	680	820	1000	1200	1500	2700
2.0					SVPE [C10] (8)		
	SVT [C65] (16)	SVT [C65] (16)	SVPA [F8] (19)			SVT [E12] (10)	SVT [F12] (12)
2.5	SVPT [C65] (16)	SVT [E7] (20)	SVPC [E12] (9)			SVPT [E12] (10)	SVPT [F12] (12)
	SVPC [C6] (16)	SVPT [C65] (16)	SVT [C65] (16)			SVPC [E12] (10)	SVPC [F12] (12)
		SVPT [E7] (20)	SVPT [C65] (16)			SVP [F12] (12)	
		SVPC [E7] (20)					
		SVP [E12] (13)					
4.0	SVT [E7] (22)	SVPA [F8] (20)			SVPC [E12] (12)	SVT [E12] (12)	
	SVPT [E7] (22)	SVPS [F8] (20)			SVP [F12] (12)	SVPT [E12] (12)	
	SVPC [E7] (22)	SVP [F8] (25)				SVPC [E12] (12)	
	SVPC [E12] (9)						
	SVP [E12] (13)						
6.3			SVT [E12] (12)				
			SVPT [E12] (12)				
			SVPC [E12] (12)				
			SVP [F12] (12)				
10	SVP [F12] (13)						
16	SVT [E10] (18)	SVPG [E12] (8)	SVPG [F10] (9)	SVT [F10] (18)	SVPG [F12] (7)		
	SVT [E12] (14)	SVPK [E12] (14)		SVT [F12] (12)	SVPK [F12] (12)		
	SVPT [E10] (16)			SVPT [F10] (16)			
	SVPT [E12] (14)			SVPT [F12] (12)			
	SVPF [E10] (18)			SVPF [F10] (16)			
	SVPF [E12] (14)			SVPF [F12] (12)			
	SVPG [E10] (10)			SVF [F10] (16)			
	SVF [E12] (14)			SVF [F12] (12)			

Size list ϕ x L (mm)

A5	4.0x5.4	B45	5.0x4.4	C6	6.3x5.9	C8	6.3x7.9	E7	8.0x6.9	F8	10.0x7.9
		B6	5.0x5.9	C65	6.3x6.4	C10	6.3x9.9	E10	8.0x10.0	F10	10.0x10.0
						C10L	6.3x10.4	E12	8.0x11.9	F12	10.0x12.6

Voltage - Capacitance table (SMD type) (Vol. : 20 to 100 V / Cap. : 6.8 to 56 μF)

Series [Size]
(ESR mΩ)

V	μF	6.8	10	12	15	18	22	27	33	39	47	56
20			SVPA [B6] (40)				SVPA [C6] (35)	SVP [C6] (60)	SVPG [B45] (27)		SVPA [E7] (33)	SVPF [B6] (30)
			SVP [B6] (120)				SVPS [C6] (60)		SVP [E7] (45)		SVPS [E7] (45)	SVF [F8] (40)
							SVQP [C6] (60)				SVQP [E7] (45)	SVF [B6] (30)
							SVP [C6] (60)				SVP [E7] (45)	
25			SVPD [C6] (65)				SVPD [E7] (48)	SVPF [B6] (40)	SVPK [B6] (35)	SVPD [F8] (45)	SVPD [E12] (30)	SVPF [C6] (30)
			SVPS [E7] (60)					SVF [B6] (40)			SVPF [C6] (30)	SVF [C6] (30)
											SVF [C6] (30)	
35						SVPD [F8] (60)	SVPD [E12] (50)				SVT [E7] (30)	SVPD [F12] (30)
							SVPF [C6] (35)				SVPT [E7] (30)	SVPK [C6] (27)
							SVF [C6] (35)				SVPF [E7] (30)	
							SVPK [B6] (35)				SVF [E7] (30)	
50			SVPF [C6] (40)			SVT [E7] (35)	SVPK [C6] (35)		SVPK [E7] (35)	SVT [E12] (25)		
			SVF [C6] (40)			SVPT [E7] (35)				SVPT [E12] (25)		
			SVPK [B6] (80)			SVPF [E7] (35)				SVPF [E12] (25)		
						SVF [E7] (35)				SVF [E12] (25)		
63					SXV [E7] (60)				SXV [E12] (25)	SXV [E12] (25)		SXV [E12] (25)
										SXV [F8] (50)		
72												
80				SXV [E7] (60)				SXV [E12] (35)	SXV [E12] (35)		SXV [E12] (35)	SXV [E12] (28, 35)
								SXV [F8] (55)			SXV [F12] (28)	SXV [F12] (28)
100		SXV [E7] (60)			SXV [E12] (40)	SXV [E12] (40)	SXV [F12] (30)	SXV [E12] (40)			SXV [F12] (30)	
					SXV [F8] (60)	SXV [F12] (30)		SXV [F12] (30)				

Size list ø x L (mm)

A5	4.0x5.4	B45	5.0x4.4	C6	6.3x5.9	C8	6.3x7.9	E7	8.0x6.9	F8	10.0x7.9
		B6	5.0x5.9	C65	6.3x6.4	C10	6.3x9.9	E10	8.0x10.0	F10	10.0x10.0
						C10L	6.3x10.4	E12	8.0x11.9	F12	10.0x12.6

Voltage - Capacitance table (SMD type) (Vol. : 20 to 100 V / Cap. : 68 to 470 μF)

Series [Size]
(ESR mΩ)

V	μF	68	82	100	120	150	180	220	270	330	390	470
20		SVPK [B6] (30)		SVP [E12] (24)	SVPF [C6] (25)	SVPK [C6] (25)	SVT [E7] (25)	SVPK [E7] (25)			SVT [E12] (14)	SVPK [E12] (14)
		SVP [F8] (40)			SVF [C6] (25)	SVP [F12] (20)	SVPT [E7] (25)	SVPG [E7] (18)			SVPT [E12] (14)	SVPG [E12] (10)
					SVPG [C6] (18)		SVPF [E7] (25)				SVPF [E12] (14)	
							SVF [E7] (25)				SVF [E12] (14)	
							SVPG [C8] (14)					
							SVPG [C10] (11)					
25			SVPD [F12] (28)	SVT [E7] (24)	SVPK [E7] (24)	SVPG [C10] (13)	SVT [E12] (16)		SVPK [E12] (16)	SVT [F12] (14)		SVPK [F12] (14)
			SVPF [E7] (28)	SVPT [E7] (24)	SVPG [C8] (15)		SVPT [E12] (16)		SVPG [E12] (12)	SVPT [F12] (14)		SVPG [F12] (10)
			SVPK [C6] (25)	SVPF [E7] (24)	SVPG [E7] (17)		SVPF [E12] (16)			SVPF [F12] (14)		
			SVF [E7] (28)	SVF [E7] (24)			SVF [E12] (16)			SVF [F12] (14)		
			SVPG [C6] (18)									
35			SVT [E12] (20)		SVT [F12] (18)		SVPK [E12] (20)			SVPK [F12] (18)		
			SVPT [E12] (20)		SVPT [F12] (18)							
			SVPF [E12] (20)		SVPF [F12] (18)							
			SVF [E12] (20)		SVF [F12] (18)							
			SVPK [E7] (25)									
50		SVT [F12] (20)			SVPK [F12] (20)							
		SVPT [F12] (20)										
		SVPF [F12] (20)										
		SVF [F12] (20)										
		SVPK [E12] (25)										
63		SXV [E12] (25)	SXV [E12] (25)	SXV [F12] (25)	SXV [F12] (25)	SXV [F12] (25)						
		SXV [F12] (25)										
72			SXV [F12] (28)	SXV [F12] (28)								
80				SXV [F12] (28)								
100												

Size list ø x L (mm)

A5	4.0x5.4	B45	5.0x4.4	C6	6.3x5.9	C8	6.3x7.9	E7	8.0x6.9	F8	10.0x7.9
		B6	5.0x5.9	C65	6.3x6.4	C10	6.3x9.9	E10	8.0x10.0	F10	10.0x10.0
						C10L	6.3x10.4	E12	8.0x11.9	F12	10.0x12.6

Voltage - Capacitance table (SMD type) (Vol. : 20 to 100 V / Cap. : 560 to 2700 μ F)

Series [Size]
(ESR m Ω)

V	μ F	560	680	820	1000	1200	1500	2700
20		SVT [F12] (12)	SVPK [F12] (12)					
		SVPT [F12] (12)	SVPG [F12] (9)					
		SVPF [F12] (12)						
		SVF [F12] (12)						
25								
35								
50								
63								
72								
80								
100								

Size list ϕ x L (mm)

A5	4.0x5.4	B45	5.0x4.4	C6	6.3x5.9	C8	6.3x7.9	E7	8.0x6.9	F8	10.0x7.9
		B6	5.0x5.9	C65	6.3x6.4	C10	6.3x9.9	E10	8.0x10.0	F10	10.0x10.0
						C10L	6.3x10.4	E12	8.0x11.9	F12	10.0x12.6

Explanation of part numbers

◇ Part number system

• Surface mount type

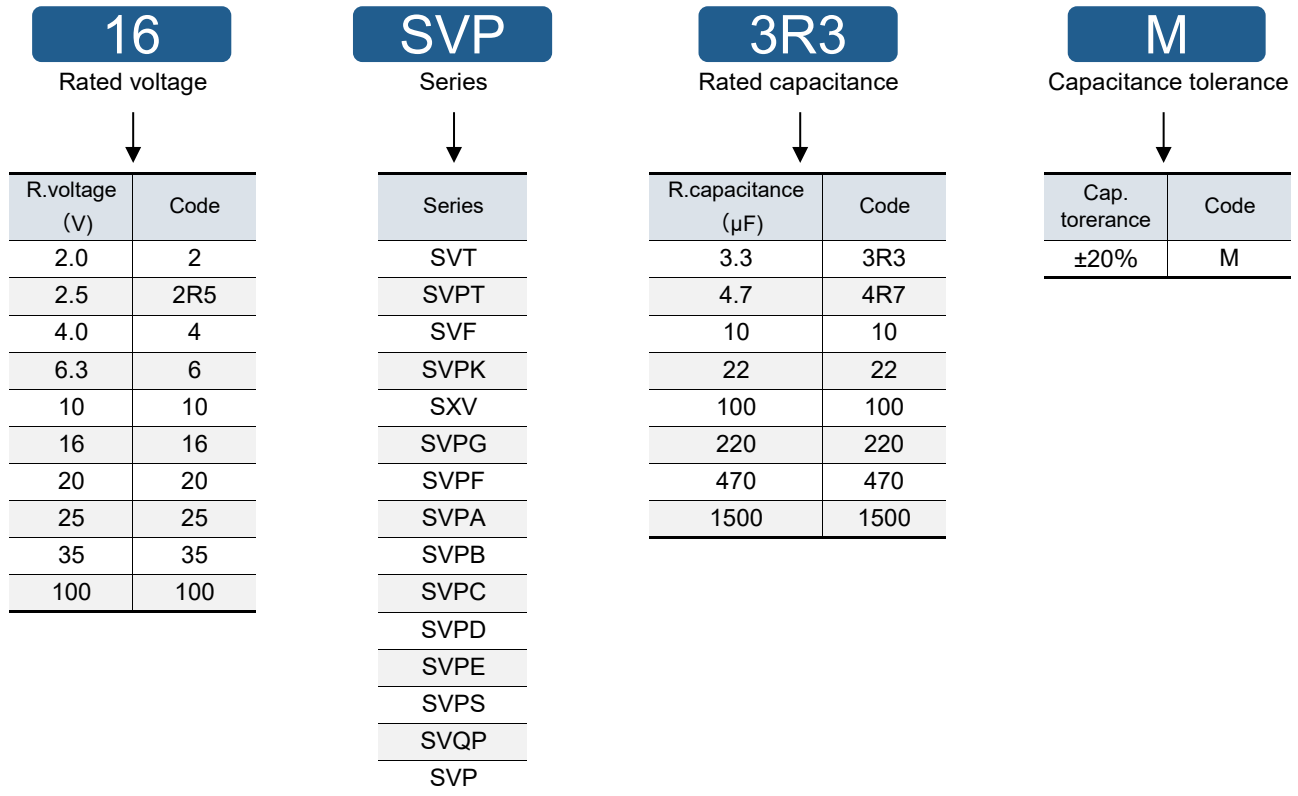

• Radial lead type

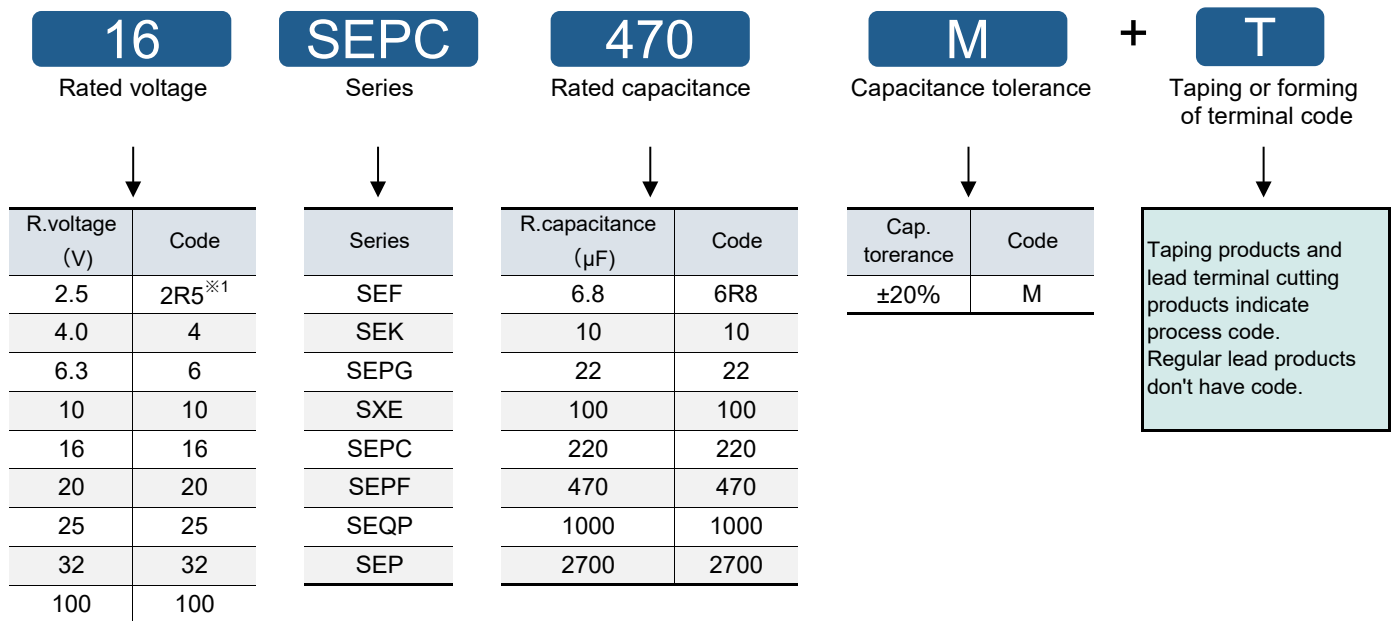

※1 Code 2 is used for 2.5 V products of B9, C6, C9, E7, E9 and F13 size in SEPC series.

Mounting specifications

◇ **Recommendable reflow soldering (SMD type)**

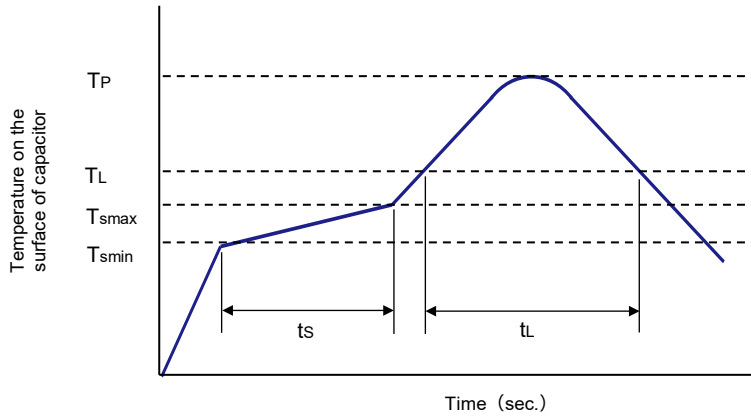

Reflow soldering		Condition A	Condition B	Condition C
		Peak temperature 260 °C lead free soldering profile	Peak temperature 250 °C lead free soldering profile	Peak temperature 250 °C lead free soldering profile (SVPG, SVPF, SVF, SVPK, SXV)
Peak temperature (T _P)		260 °C	250 °C	250 °C
Soldering time (t _L) above soldering temperature (T _L)	T _L ≥ 245 °C	—		30 seconds max.
	T _L ≥ 230 °C	40 seconds max.		—
	T _L ≥ 220 °C	50 seconds max.		—
	T _L ≥ 217 °C	—		90 seconds max.
Preheat		180 °C		200 °C*1
Temperature max. (T _{smax})		150 °C		—
Temperature min. (T _{smin})		120 seconds max.		—
Time (t _s) from (T _{smin}) to (T _{smax})		1 times		2 times
The cycles of reflow soldering		2 times		2 times

*1 SXV series : 180°C

◇ **Flow soldering (Radial lead type)**

	Temperature	Time	Flow number
Preheating	120 °C or less (ambient temperature)	120 sec. or less	1 time
Soldering condition	260 °C+5 °C or less	10+1 sec. or less	2 times or less*1

*1 : When soldering 2 times, total immersion time should be 10+1 sec. or less.

◇ **Soldering with a soldering iron**

Tip of a soldering iron : 400 °C±10 °C
Working time : 5 sec. max.

Land Pattern

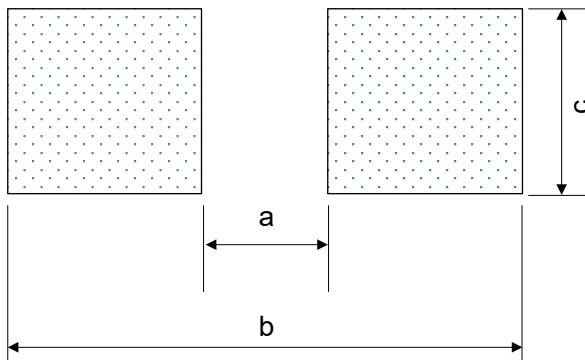

Size code	Unit : mm		
	a	b	c
A5	1.0	6.2	1.6
B45	1.4	7.4	1.6
B6	1.4	7.4	1.6
C6	2.1	9.1	1.6
C65	2.1	9.1	1.6
C8	2.1	9.1	1.6
C10	2.1	9.1	1.6
C10L	2.1	9.1	2.5
E7	2.8	11.1	1.9
E10	2.8	11.1	1.9
E12	2.8	11.1	1.9
F8	4.3	13.1	1.9
F10	4.3	13.1	1.9
F12	4.3	13.1	1.9

Packing specifications

◇ SMD type

● Taping

1-1. Carrier tape

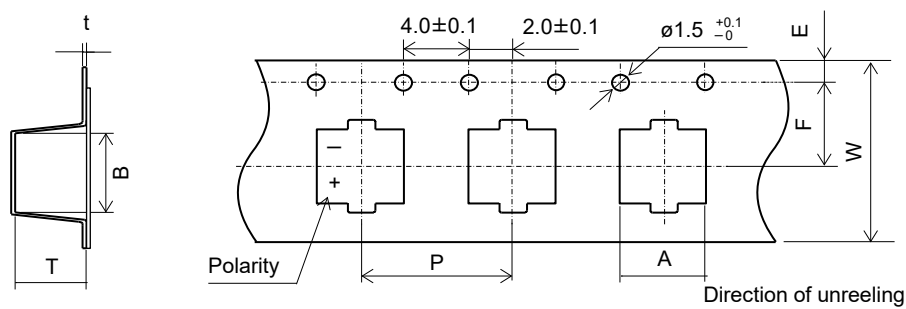

Size code	A±0.2	B±0.2	W±0.3	F±0.1	E±0.1	P±0.1	t±0.1	T±0.2
A5	4.7	4.7	12.0	5.5	1.75	8.0	0.4	5.8
B45	5.6	5.6	16.0	7.5	1.75	8.0	0.4	4.8
B6	5.6	5.6	16.0	7.5	1.75	8.0	0.4	6.2
C6	6.9	6.9	16.0	7.5	1.75	12.0	0.4	6.2
C65	6.9	6.9	16.0	7.5	1.75	12.0	0.4	6.7
C8	7.0	7.0	16.0	7.5	1.75	12.0	0.5	8.2
C10	7.0	7.0	24.0	11.5	1.75	16.0	0.5	10.5
C10L	7.0	7.0	16.0	7.5	1.75	12.0	0.5	11.0
E7	8.6	8.6	24.0	11.5	1.75	12.0	0.4	7.2
E10	8.6	8.6	24.0	11.5	1.75	16.0	0.5	11.0
E12	8.6	8.6	24.0	11.5	1.75	16.0	0.5	12.3
F8	10.7	10.7	24.0	11.5	1.75	16.0	0.4	8.2
F10	10.7	10.7	24.0	11.5	1.75	16.0	0.4	11.0
F12	10.7	10.7	24.0	11.5	1.75	16.0	0.4	13.0

1-2. Reel

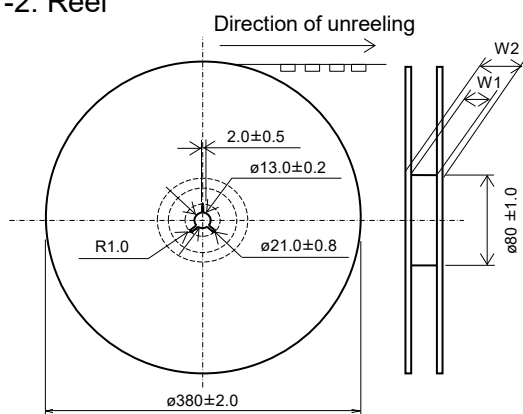

Size code	W1±0.5	W2±1.0
A5	13.0	17.5
B45, B6, C6, C65, C8, C10L	17.0	21.5
C10, E7, E10, E12, F8, F10, F12	25.0	29.5

● Minimum packing quantity and weight

Size code	Quantity (pcs./Reel, ø380)	Typical weight (g)
A5	2000	700
B45	2500	900
B6	1500	800
C6	1000	800
C65	1000	800
C8	900	800
C10	500	700
C10L	700	900

Size code	Quantity (pcs./Reel, ø380)	Typical weight (g)
E7	1000	1100
E10	500	900
E12	400	800
F8	500	1000
F10	500	1000
F12	400	1000

Packing specifications

◆ Radial lead type (Not recommended for new design)

● Lead terminal process

1-1. Correspondence list

※ The following table is a standard specification. Please contact us separately concerning specifications except for that mentioned below.
 Because of a limit on the length of a model name, the part of process name changes to +S from +TSS, +D from +TS, +3 from +C3. Please contact us for details.

Series	Size code	Bag-packed products (lead terminal cutting)		Taping products
		Not processed	Straight cut	
SEP, SEQP, SEPC	B9, C55, C6, C9, C10, E7, E9, E12	No code	+C3 (+3)	+TSS (+S)
SEPF, SXE, SEPG	E13	No code	+C3 (+3)	+TS (+D)
SEF, SEK	F8, F13	No code	+C3 (+3)	+T

1-2. Lead terminal cutting specifications

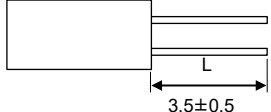
Process names	Size code	Lead terminal cutting code	Lead terminal dimensions
Straight cut	B9 C55, C6, C9, C10 E7, E9, E12, E13 F8, F13	+C3 (+3)	 Unit : mm

1-3. Taping specifications for automatic insertion

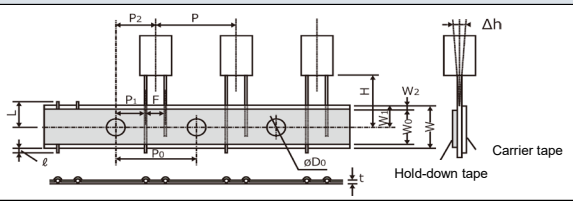
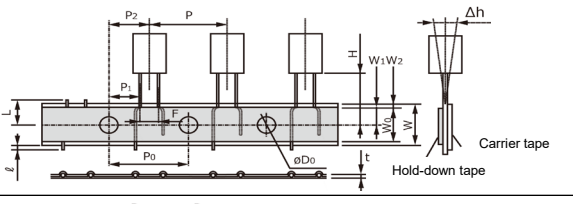
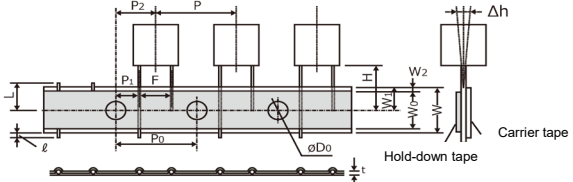
Size code	Case size	F	Taping code	Taping dimensions
B9	ø5	F=2.0 mm	+TSS (+S)	
C55, C6, C9, C10	ø6.3	F=2.5 mm		
E7, E9, E12	ø8	F=3.5 mm		
E13	ø8	F=3.5 mm	+TS (+D)	
F8, F13	ø10	F=5.0 mm	+T	

Taping code	Case size	F	P	P ₀	P ₁	P ₂	Δh	W	W ₀	W ₁	W ₂	H	øD ₀
		^{+0.8} / _{-0.2}	±1.0	±0.2	±0.5	±1.0	±1.0	±0.5	min.	±0.5	max.	±0.75	±0.2
+TSS (+S)	ø5	2.0	12.7	12.7	5.35	6.35	0	18.0	9.5	9.0	2.5	17.5	4.0
	ø6.3	2.5	12.7	12.7	5.10	6.35	0	18.0	9.5	9.0	2.5	17.5	4.0
	ø8	3.5	12.7	12.7	4.60	6.35	0	18.0	9.5	9.0	2.5	17.5	4.0
+TS (+D)	ø8	3.5	12.7	12.7	4.60	6.35	0	18.0	9.5	9.0	2.5	17.5	4.0
+T	ø10	5.0	12.7	12.7	3.85	6.35	0	18.0	9.5	9.0	2.5	18.5	4.0

Taping code	Case size	t	ℓ	L
		±0.3	max.	max.
+TSS (+S)	ø5	0.6	0	11.0
	ø6.3	0.6	0	11.0
	ø8	0.6	0	11.0
+TS (+D)	ø8	0.6	0	11.0
+T	ø10	0.6	0	11.0

Unit : mm

● Minimum packing quantity and weight

Size code	Case size	Bag-packed products		Taping products	
		Quantity(pcs./Bag)	Typical weight(g)	Quantity(pcs./Bag)	Typical weight(g)
B9	ø5	500	180	2000	1000
C55	ø6.3	500	150	1500	650
C6	ø6.3	500	160	1500	700
C9	ø6.3	500	240	1500	1000
C10	ø6.3	500	260	1500	1100

Size code	Case size	Bag-packed products		Taping products	
		Quantity(pcs./Bag)	Typical weight(g)	Quantity(pcs./Bag)	Typical weight(g)
E7	ø8	200	110	1000	820
E9	ø8	200	130	1000	900
E12	ø8	200	200	1000	980
E13	ø8	200	160	1000	1060
F8	ø10	200	180	500	890
F13	ø10	200	280	500	940

**Conductive Polymer Aluminum
Solid Capacitors**
Surface Mount Type
SVT series

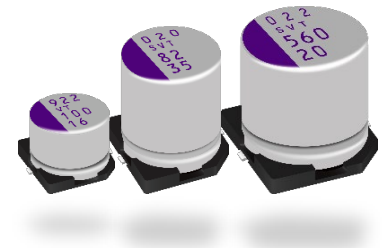

Features

- Low ESR (10 mΩ max.)
- Large capacitance (2700 μF max.)
- 125 °C 2000 h
- RoHS compliance, Halogen free

Specifications

Size code	C65	E7	E10	E12	F10	F12
Category temp. range	-55 °C to +125 °C					
Rated voltage range (V)	2.5 to 16	2.5 to 50	16	2.5 to 50	16	2.5 to 50
Nominal cap. range (μF)	100 to 820	18 to 680	560	39 to 1500	1000	68 to 2700
Capacitance tolerance	±20 % (120 Hz / +20 °C)					
DC leakage current	Please see the attached characteristics list					
Dissipation factor (tan δ)	Please see the attached characteristics list					
Endurance	+125 °C 2000 h, rated voltage applied					
	Capacitance change	Within ±20 % of the initial value				
	Dissipation factor (tanδ)	≤ 200 % of the initial limit				
	DC leakage current	Within the initial limit				
Damp heat (Steady state)	+60 °C, 90 % to 95 % RH, 1000 h, No-applied voltage					
	Capacitance change	Within ±20 % of the initial value				
	Dissipation factor (tanδ)	≤ 150 % of the initial limit				
	DC leakage current	Within the initial limit (after voltage processing)				

Marking

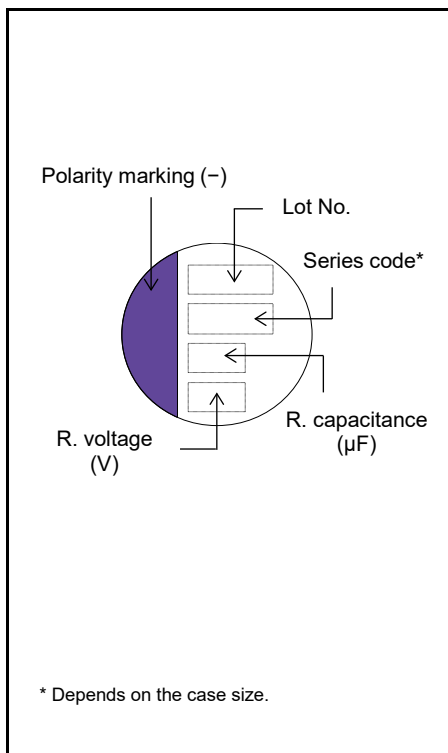

Dimensions (not to scale)

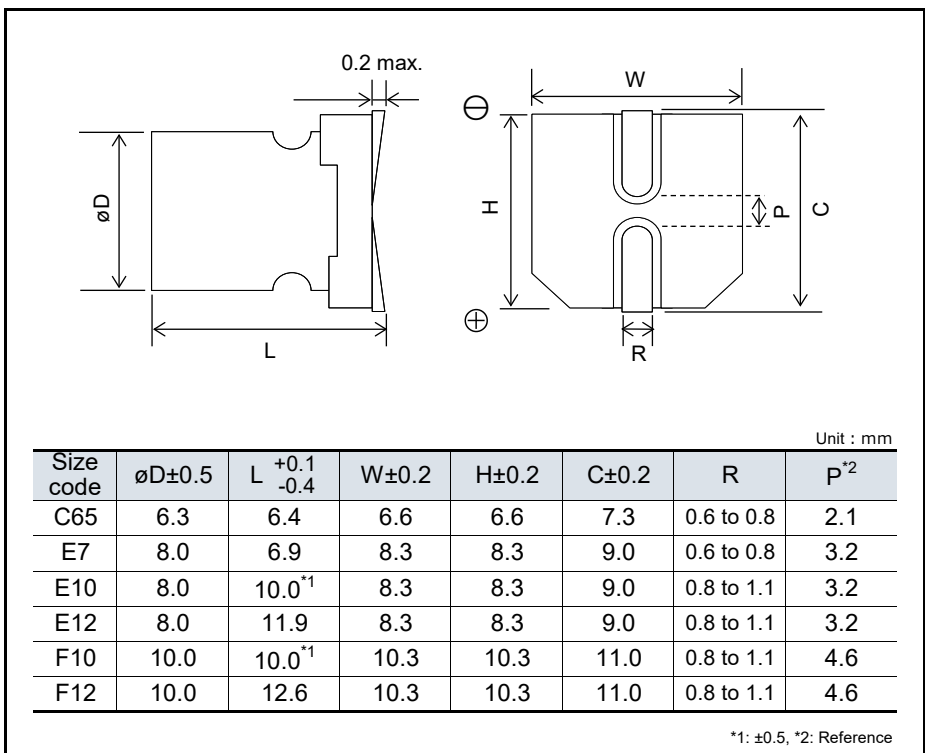

Characteristics list

Rated voltage (V)	Rated capacitance ($\pm 20\%$) (μF)	Case size (mm)		Size code	Specifications					Standard (Reel size : $\phi 380$)	
		ϕD	L		Ripple current* ¹ (mA rms)	Allowable ripple current* ¹ (mA rms)	ESR* ² (m Ω max.)	$\tan \delta$ * ³	LC* ⁴ (μA)	Part number	Min. Packaging Q'ty (pcs)
2.5	560	6.3	6.4	C65	1100	3500	16	0.12	300	2R5SVT560M	1000
	680	6.3	6.4		1000	3500	16	0.12	850	2R5SVT680MX	1000
			8.0	6.9	E7	1060	3370	20	0.12	500	2R5SVT680M
	820	6.3	6.4	C65	1100	3500	16	0.12	1020	2R5SVT820M	1000
	1500	8.0	11.9	E12	1620	5150	10	0.12	750	2R5SVT1500M	400
	2700	10.0	12.6	F12	1600	5070	12	0.12	1350	2R5SVT2700M	400
4.0	560	8.0	6.9	E7	1010	3220	22	0.12	500	4SVT560M	1000
	1500	8.0	11.9	E12	1480	4700	12	0.12	1200	4SVT1500M	400
6.3	330	6.3	6.4	C65	1070	3390	15	0.12	415	6SVT330M	1000
	390	8.0	6.9	E7	1010	3220	22	0.12	491	6SVT390M	1000
	820	8.0	11.9	E12	1480	4700	12	0.12	1033	6SVT820M	400
16	100	6.3	6.4	C65	780	2490	24	0.12	300	16SVT100M	1000
	270	8.0	6.9	E7	1040	3300	22	0.12	864	16SVT270M	1000
	560	8.0	10.0	E10	1230	3900	18	0.12	1792	16SVT560MX	500
	560	8.0	11.9	E12	1560	4950	14	0.12	1792	16SVT560M	400
	1000	10.0	10.0	F10	1350	4300	16	0.12	3200	16SVT1000MX	500
	1000	10.0	12.6	F12	1700	5400	12	0.12	3200	16SVT1000M	400
20	180	8.0	6.9	E7	1010	3200	25	0.12	720	20SVT180M	1000
	390	8.0	11.9	E12	1560	4950	14	0.12	1560	20SVT390M	400
	560	10.0	12.6	F12	1700	5400	12	0.12	2240	20SVT560M	400
25	100	8.0	6.9	E7	1010	3200	24	0.12	500	25SVT100M	1000
	180	8.0	11.9	E12	1470	4650	16	0.12	900	25SVT180M	400
	330	10.0	12.6	F12	1580	5000	14	0.12	1650	25SVT330M	400
35	39	8.0	6.9	E7	880	2800	30	0.12	273	35SVT39M	1000
	82	8.0	11.9	E12	1260	4000	20	0.12	574	35SVT82M	400
	120	10.0	12.6	F12	1390	4400	18	0.12	840	35SVT120M	400
50	18	8.0	6.9	E7	850	2700	35	0.12	180	50SVT18M	1000
	39	8.0	11.9	E12	1200	3800	25	0.12	390	50SVT39M	400
	68	10.0	12.6	F12	1350	4300	20	0.12	680	50SVT68M	400

*1: Ripple current (100 kHz / $+105\text{ }^\circ\text{C} < T_x \leq +125\text{ }^\circ\text{C}$) / Allowable ripple current (100 kHz / $T_x \leq +105\text{ }^\circ\text{C}$)

Tx: Temperature measured at the top surface of aluminum case including self-heating by ripple current

*2: ESR (100 kHz to 300 kHz / $+20\text{ }^\circ\text{C}$)

*3: $\tan \delta$ (120 Hz / $+20\text{ }^\circ\text{C}$)

*4: After 2 minutes

◆ Please refer to each page in this catalog for "Reflow conditions" and "Taping specifications".

Frequency correction factor for ripple current

Frequency(f)	$120\text{ Hz} \leq f < 1\text{ kHz}$	$1\text{ kHz} \leq f < 10\text{ kHz}$	$10\text{ kHz} \leq f < 100\text{ kHz}$	$100\text{ kHz} \leq f < 500\text{ kHz}$
Coefficient	0.05	0.3	0.7	1

**Conductive Polymer Aluminum
Solid Capacitors**
Surface Mount Type
SVPT series

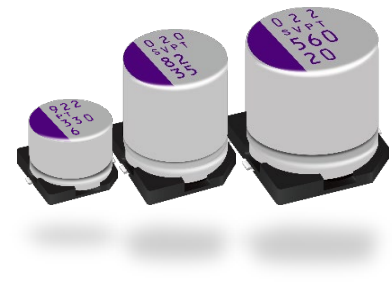

Features

- Low ESR (10 mΩ max.)
- Large capacitance (2700 μF max.)
- 105 °C 20000 h
- RoHS compliance, Halogen free

Specifications

Size code	C65	E7	E10	E12	F10	F12
Category temp. range	-55 °C to +105 °C					
Rated voltage range (V)	2.5 to 16	2.5 to 50	16	2.5 to 50	16	2.5 to 50
Nominal cap. range (μF)	100 to 820	18 to 680	560	39 to 1500	1000	68 to 2700
Capacitance tolerance	±20 % (120 Hz / +20 °C)					
DC leakage current	Please see the attached characteristics list					
Dissipation factor (tan δ)	Please see the attached characteristics list					
Endurance	+105 °C 20000 h, rated voltage applied					
	Capacitance change	Within ±20 % of the initial value				
	Dissipation factor (tanδ)	≤ 150 % of the initial limit				
	DC leakage current	Within the initial limit				
Damp heat (Steady state)	+60 °C, 90 % to 95 % RH, 1000 h, No-applied voltage					
	Capacitance change	Within ±20 % of the initial value				
	Dissipation factor (tanδ)	≤ 150 % of the initial limit				
	DC leakage current	Within the initial limit (after voltage processing)				

Marking

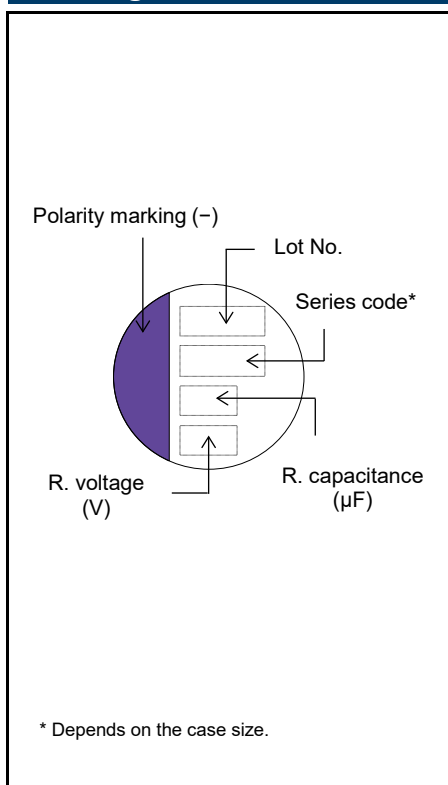

Dimensions (not to scale)

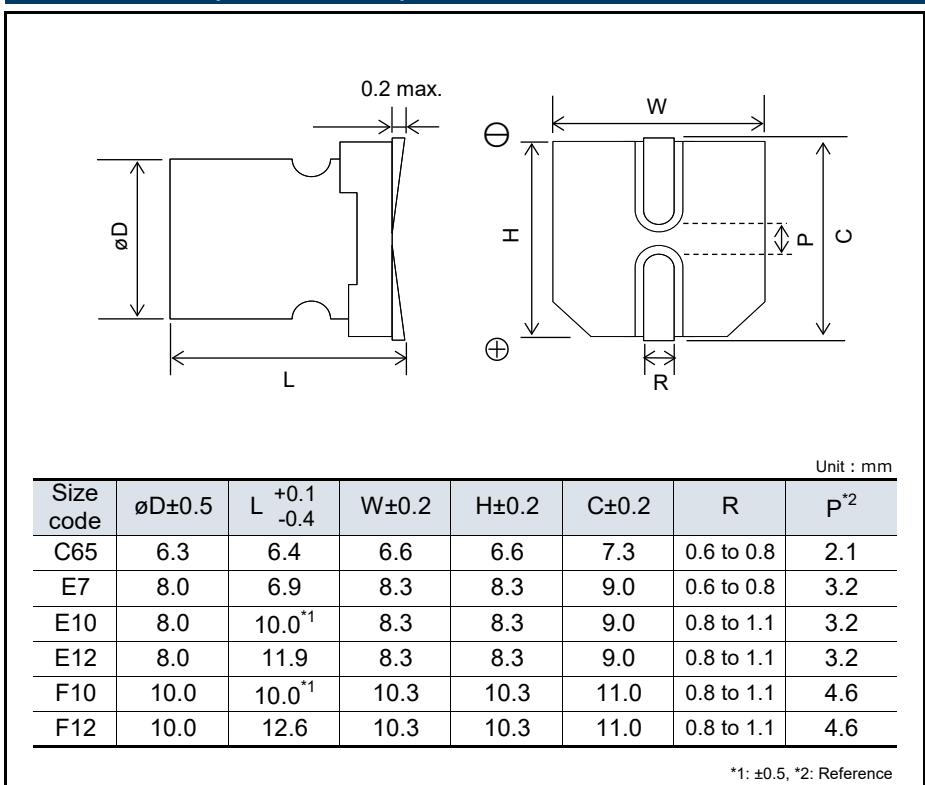

Characteristics list

Rated voltage (V)	Rated capacitance ($\pm 20\%$) (μF)	Case size (mm)		Size code	Specifications				Standard (Reel size : $\phi 380$)	
		ϕD	L		Ripple current ^{*1} (mA rms)	ESR ^{*2} (m Ω max.)	$\tan \delta$ ^{*3}	LC ^{*4} (μA)	Part number	Min. Packaging Q'ty (pcs)
2.5	560	6.3	6.4	C65	3500	16	0.12	300	2R5SVPT560M	1000
	680	6.3	6.4		3500	16	0.12	850	2R5SVPT680MX	1000
		8.0	6.9	E7	3370	20	0.12	500	2R5SVPT680M	1000
	820	6.3	6.4	C65	3500	16	0.12	1020	2R5SVPT820M	1000
	1500	8.0	11.9	E12	5150	10	0.12	750	2R5SVPT1500M	400
4.0	2700	10.0	12.6	F12	5070	12	0.12	1350	2R5SVPT2700M	400
	560	8.0	6.9	E7	3220	22	0.12	500	4SVPT560M	1000
6.3	1500	8.0	11.9	E12	4700	12	0.12	1200	4SVPT1500M	400
	330	6.3	6.4	C65	3390	15	0.12	415	6SVPT330M	1000
	390	8.0	6.9	E7	3220	22	0.12	491	6SVPT390M	1000
16	820	8.0	11.9	E12	4700	12	0.12	1033	6SVPT820M	400
	100	6.3	6.4	C65	2490	24	0.12	300	16SVPT100M	1000
	270	8.0	6.9	E7	3300	22	0.12	864	16SVPT270M	1000
	560	8.0	10.0	E10	3900	18	0.12	1792	16SVPT560MX	500
	560	8.0	11.9	E12	4950	14	0.12	1792	16SVPT560M	400
	1000	10.0	10.0	F10	4300	16	0.12	3200	16SVPT1000MX	500
20	1000	10.0	12.6	F12	5400	12	0.12	3200	16SVPT1000M	400
	180	8.0	6.9	E7	3200	25	0.12	720	20SVPT180M	1000
	390	8.0	11.9	E12	4950	14	0.12	1560	20SVPT390M	400
25	560	10.0	12.6	F12	5400	12	0.12	2240	20SVPT560M	400
	100	8.0	6.9	E7	3200	24	0.12	500	25SVPT100M	1000
	180	8.0	11.9	E12	4650	16	0.12	900	25SVPT180M	400
35	330	10.0	12.6	F12	5000	14	0.12	1650	25SVPT330M	400
	39	8.0	6.9	E7	2800	30	0.12	273	35SVPT39M	1000
	82	8.0	11.9	E12	4000	20	0.12	574	35SVPT82M	400
50	120	10.0	12.6	F12	4400	18	0.12	840	35SVPT120M	400
	18	8.0	6.9	E7	2700	35	0.12	180	50SVPT18M	1000
	39	8.0	11.9	E12	3800	25	0.12	390	50SVPT39M	400
	68	10.0	12.6	F12	4300	20	0.12	680	50SVPT68M	400

*1: Ripple current (100 kHz / +105 °C)

The surface temperature of aluminum case top must not exceed 105 °C. A rise in temperature due to self-heating by ripple current should be factored in.

*2: ESR (100 kHz to 300 kHz / +20 °C)

*3: $\tan \delta$ (120 Hz / +20 °C)

*4: After 2 minutes

◆ Please refer to each page in this catalog for "Reflow conditions" and "Taping specifications".

Frequency correction factor for ripple current

Frequency(f)	120 Hz \leq f < 1 kHz	1 kHz \leq f < 10 kHz	10 kHz \leq f < 100 kHz	100 kHz \leq f < 500 kHz
Coefficient	0.05	0.3	0.7	1

**Conductive Polymer Aluminum
Solid Capacitors**
Surface Mount Type
SVF series

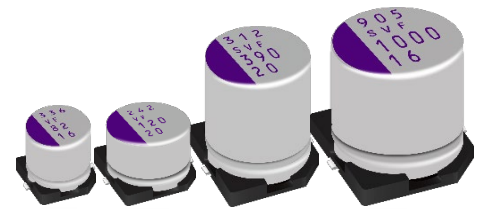

Features

- High voltage (50 V max.)
- Large capacitance (1000 μF max.)
- 125 °C 1000 h
- RoHS compliance, Halogen free

Specifications

Size code	B6	C6	E7	E12	F10	F12
Category temp. range	-55 °C to +125 °C					
Rated voltage range	16 V to 25 V	16 V to 50 V			16 V	16 V to 50 V
Nominal cap.range	27 μF to 82 μF	10 μF to 180 μF	18 μF to 270 μF	39 μF to 560 μF	1000 μF	68 μF to 1000 μF
Capacitance tolerance	±20 % (120 Hz / +20 °C)					
DC leakage current	Please see the attached characteristics list					
Dissipation factor (tan δ)	Please see the attached characteristics list					
Endurance	+125 °C 1000 h, rated voltage applied					
	Capacitance change	Within ±20 % of the initial value				
	Dissipation factor (tanδ)	≤ 200 % of the initial limit				
	DC leakage current	Within the initial limit				
Damp heat (Steady state)	+60 °C, 90 % to 95 % RH, 1000 h, No-applied voltage					
	Capacitance change	Within ±20 % of the initial value				
	Dissipation factor (tanδ)	≤ 150 % of the initial limit				
	DC leakage current	Within the initial limit (after voltage processing)				

Marking

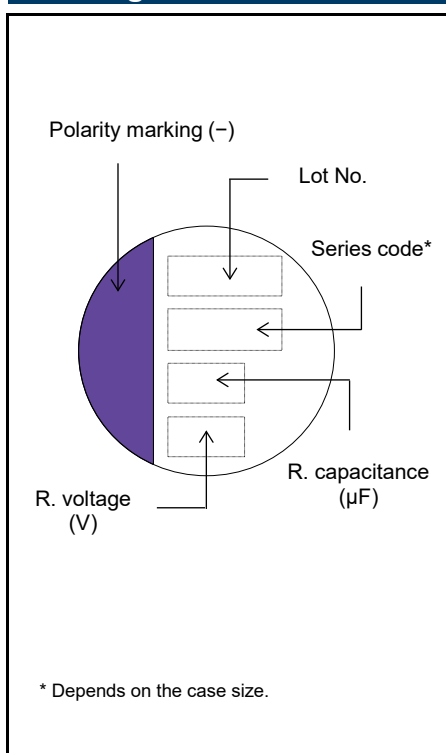

Dimensions (not to scale)

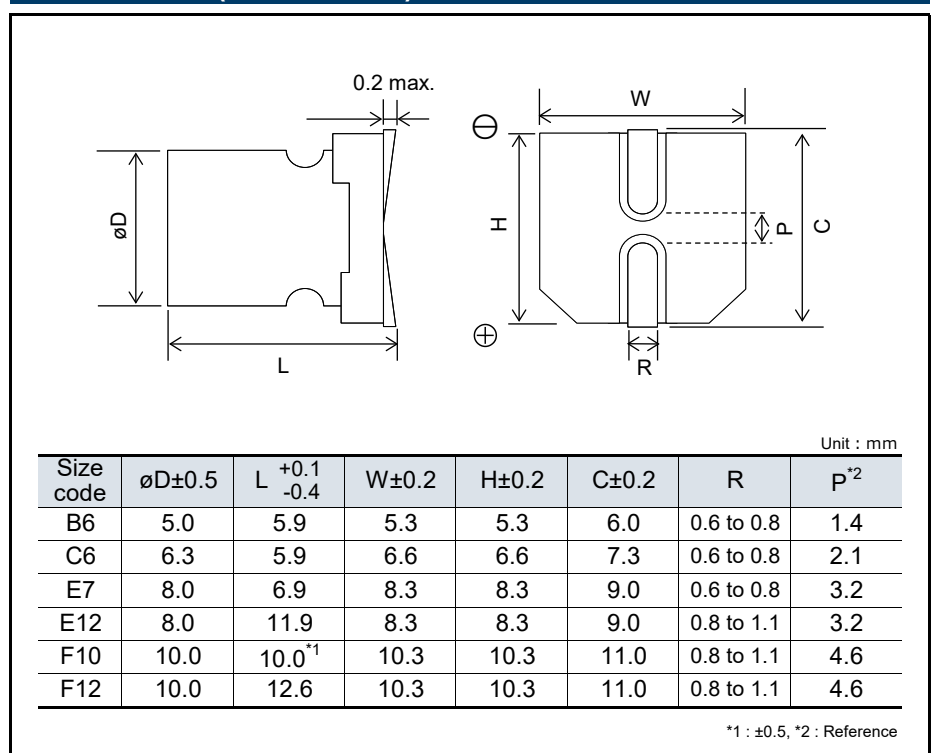

Characteristics list

Rated voltage (V)	Rated capacitance (±20 %) (μF)	Case size (mm)		Size code	Specifications					Standard (Reel size : ø380)	
		øD	L		Ripple current* ¹ (mA rms)	Allowable ripple current* ¹ (mA rms)	ESR* ² (mΩ max.)	tan δ* ³	LC* ⁴ (μA)	Part number	Min. Packaging Q'ty (pcs)
16	82	5.0	5.9	B6	940	3000	27	0.12	262	16SVF82M	1500
	180	6.3	5.9	C6	1040	3300	22	0.12	576	16SVF180M	1000
	270	8.0	6.9	E7	1040	3300	22	0.12	864	16SVF270M	1000
	560	8.0	11.9	E12	1560	4950	14	0.12	1792	16SVF560M	400
	1000	10.0	10.0	F10	1350	4300	16	0.12	3200	16SVF1000MX	500
		10.0	12.6	F12	1700	5400	12	0.12	3200	16SVF1000M	400
20	56	5.0	5.9	B6	880	2800	30	0.12	224	20SVF56M	1500
	120	6.3	5.9	C6	1010	3200	25	0.12	480	20SVF120M	1000
	180	8.0	6.9	E7	1010	3200	25	0.12	720	20SVF180M	1000
	390	8.0	11.9	E12	1560	4950	14	0.12	1560	20SVF390M	400
	560	10.0	12.6	F12	1700	5400	12	0.12	2240	20SVF560M	400
25	27	5.0	5.9	B6	770	2450	40	0.12	135	25SVF27M	1500
	47	6.3	5.9	C6	880	2800	30	0.12	235	25SVF47M	1000
	56	6.3	5.9		880	2800	30	0.12	280	25SVF56M	1000
	82	8.0	6.9	E7	940	3000	28	0.12	410	25SVF82M	1000
	100	8.0	6.9		1010	3200	24	0.12	500	25SVF100M	1000
	180	8.0	11.9	E12	1470	4650	16	0.12	900	25SVF180M	400
	330	10.0	12.6	F12	1580	5000	14	0.12	1650	25SVF330M	400
35	22	6.3	5.9	C6	820	2600	35	0.12	154	35SVF22M	1000
	39	8.0	6.9	E7	880	2800	30	0.12	273	35SVF39M	1000
	82	8.0	11.9	E12	1260	4000	20	0.12	574	35SVF82M	400
	120	10.0	12.6	F12	1390	4400	18	0.12	840	35SVF120M	400
50	10	6.3	5.9	C6	790	2500	40	0.12	100	50SVF10M	1000
	18	8.0	6.9	E7	850	2700	35	0.12	180	50SVF18M	1000
	39	8.0	11.9	E12	1200	3800	25	0.12	390	50SVF39M	400
	68	10.0	12.6	F12	1350	4300	20	0.12	680	50SVF68M	400

*1: Ripple current (100 kHz / +105 °C < Tx ≤ +125 °C) / Allowable ripple current (100 kHz / Tx ≤ +105 °C)

*2: ESR (100 kHz to 300 kHz / +20 °C)

*3: tan δ (120 Hz / +20 °C)

*4: After 2 minutes

◆ Please refer to each page in this catalog for "Reflow conditions" and "Taping specifications".

Frequency correction factor for ripple current

Frequency(f)	120 Hz ≤ f < 1 kHz	1 kHz ≤ f < 10 kHz	10 kHz ≤ f < 100 kHz	100 kHz ≤ f < 500 kHz
Coefficient	0.05	0.3	0.7	1

**Conductive Polymer Aluminum
Solid Capacitors**
Surface Mount Type
SVPK series



Features

- High voltage (50 V max.)
- 125 °C 1000 h
- RoHS compliance, Halogen free

Specifications

Size code	B6	C6	E7	E12	F12
Category temp. range	-55 °C to +125 °C				
Rated voltage range	16 V to 50 V				
Nominal cap.range	10 µF to 100 µF	22 µF to 220 µF	33 µF to 330 µF	68 µF to 680 µF	120 µF to 1200 µF
Capacitance tolerance	±20 % (120 Hz / +20 °C)				
DC leakage current	Please see the attached characteristics list				
Dissipation factor (tan δ)	Please see the attached characteristics list				
Endurance	+125 °C 1000 h, rated voltage applied				
	Capacitance change	Within ±20 % of the initial value			
	Dissipation factor (tanδ)	≤ 200 % of the initial limit			
	DC leakage current	Within the initial limit			
Damp heat (Steady state)	+60 °C, 90 % to 95 % RH, 1000 h, No-applied voltage				
	Capacitance change	Within ±20 % of the initial value			
	Dissipation factor (tanδ)	≤ 150 % of the initial limit			
	DC leakage current	Within the initial limit (after voltage processing)			

Marking

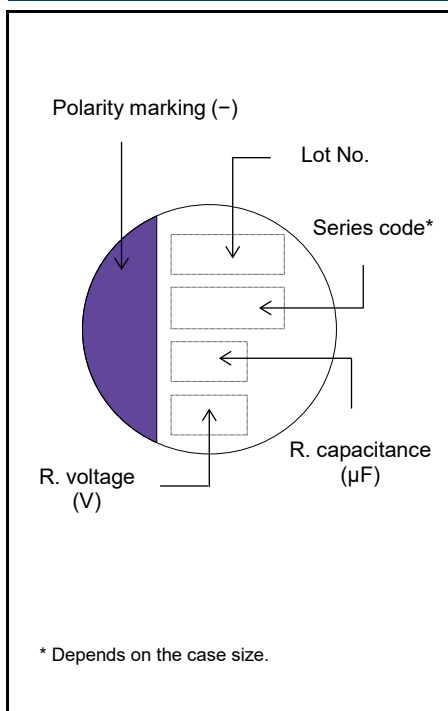

Dimensions (not to scale)

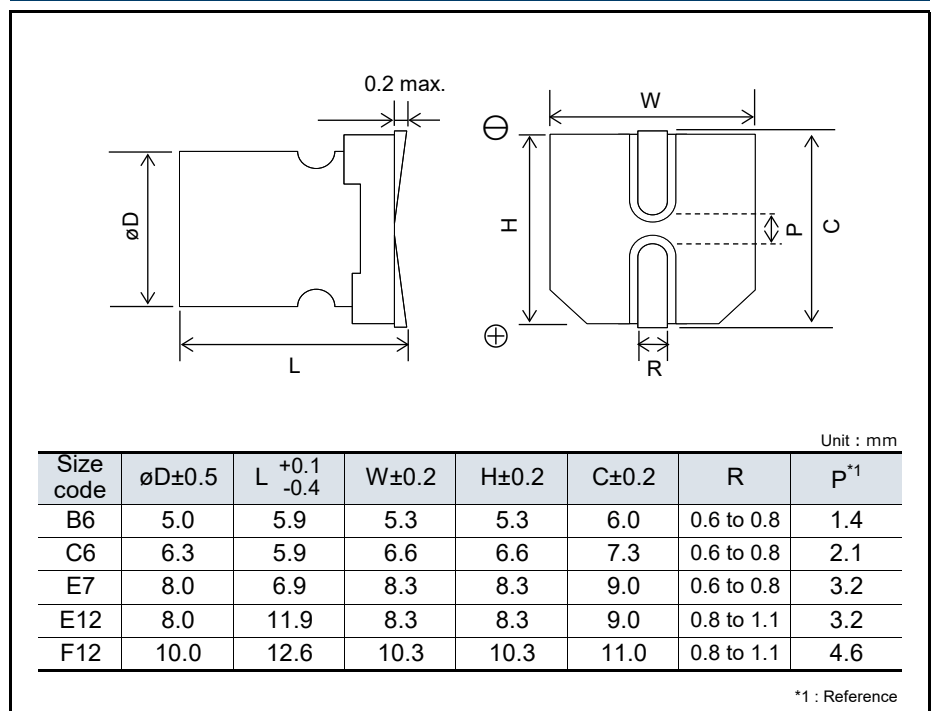

Characteristics list

Rated voltage (V)	Rated capacitance (±20 %) (μF)	Case size (mm)		Size code	Specifications					Standard (Reel size : ø380)	
		øD	L		Ripple current* ¹ (mA rms)	Allowable ripple current* ¹ (mA rms)	ESR* ² (mΩ max.)	tan δ* ³	LC* ⁴ (μA)	Part number	Min. Packaging Q'ty (pcs)
16	100	5.0	5.9	B6	940	3000	27	0.12	320	16SVPK100M	1500
	220	6.3	5.9	C6	1040	3300	22	0.12	704	16SVPK220M	1000
	330	8.0	6.9	E7	1040	3300	22	0.12	1056	16SVPK330M	1000
	680	8.0	11.9	E12	1560	4950	14	0.12	2176	16SVPK680M	400
	1200	10.0	12.6	F12	1700	5400	12	0.12	3840	16SVPK1200M	400
20	68	5.0	5.9	B6	880	2800	30	0.12	272	20SVPK68M	1500
	150	6.3	5.9	C6	1010	3200	25	0.12	600	20SVPK150M	1000
	220	8.0	6.9	E7	1010	3200	25	0.12	880	20SVPK220M	1000
	470	8.0	11.9	E12	1560	4950	14	0.12	1880	20SVPK470M	400
	680	10.0	12.6	F12	1700	5400	12	0.12	2720	20SVPK680M	400
25	33	5.0	5.9	B6	820	2600	35	0.12	165	25SVPK33M	1500
	82	6.3	5.9	C6	960	3060	25	0.12	410	25SVPK82M	1000
	120	8.0	6.9	E7	1010	3200	24	0.12	600	25SVPK120M	1000
	270	8.0	11.9	E12	1470	4650	16	0.12	1350	25SVPK270M	400
	470	10.0	12.6	F12	1590	5000	14	0.12	2350	25SVPK470M	400
35	22	5.0	5.9	B6	820	2600	35	0.12	154	35SVPK22M	1500
	47	6.3	5.9	C6	930	2950	27	0.12	329	35SVPK47M	1000
	82	8.0	6.9	E7	960	3060	25	0.12	574	35SVPK82M	1000
	180	8.0	11.9	E12	1260	4000	20	0.12	1260	35SVPK180M	400
	330	10.0	12.6	F12	1390	4400	18	0.12	2310	35SVPK330M	400
50	10	5.0	5.9	B6	550	1750	80	0.12	100	50SVPK10M	1500
	22	6.3	5.9	C6	820	2600	35	0.12	220	50SVPK22M	1000
	33	8.0	6.9	E7	850	2700	35	0.12	330	50SVPK33M	1000
	68	8.0	11.9	E12	1200	3800	25	0.12	680	50SVPK68M	400
	120	10.0	12.6	F12	1350	4300	20	0.12	1200	50SVPK120M	400

*1: Ripple current (100 kHz / +105 °C < Tx ≤ +125 °C) / Allowable ripple current (100 kHz / Tx ≤ +105 °C)

*2: ESR (100 kHz to 300 kHz / +20 °C)

*3: tan δ (120 Hz / +20 °C)

*4: After 2 minutes

◆ Please refer to each page in this catalog for "Reflow conditions" and "Taping specifications".

Frequency correction factor for ripple current

Frequency(f)	120 Hz ≤ f < 1 kHz	1 kHz ≤ f < 10 kHz	10 kHz ≤ f < 100 kHz	100 kHz ≤ f < 500 kHz
Coefficient	0.05	0.3	0.7	1

**Conductive Polymer Aluminum
Solid Capacitors**
Surface Mount Type
SXV series



Features

- Super high voltage (100 V max.)
- 125 °C 1000 h
- RoHS compliance, Halogen free

Specifications

Size code	E7	E12	F8	F12
Category temp. range	-55 °C to +125 °C			
Rated voltage range	63 V to 100 V			
Nominal cap.range	6.8 μF to 18 μF	15 μF to 82 μF	15 μF to 39 μF	18 μF to 150 μF
Capacitance tolerance	±20 % (120 Hz / +20 °C)			
DC leakage current	Please see the attached characteristics list			
Dissipation factor (tan δ)	Please see the attached characteristics list			
Endurance	+125 °C 1000 h, rated voltage applied			
	Capacitance change	Within ±20 % of the initial value		
	Dissipation factor (tanδ)			
Damp heat (Steady state)	+60 °C, 90 % to 95 % RH, 1000 h, No-applied voltage			
	Capacitance change	Within ±20 % of the initial value		
	Dissipation factor (tanδ)	≤ 150 % of the initial limit		
	DC leakage current	Within the initial limit (after voltage processing)		

Marking

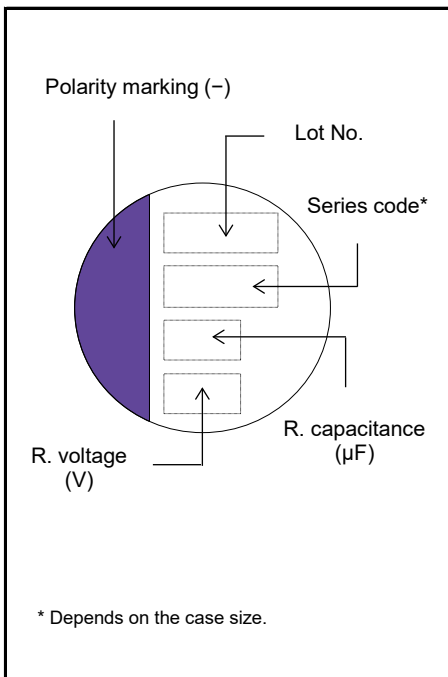

Dimensions (not to scale)

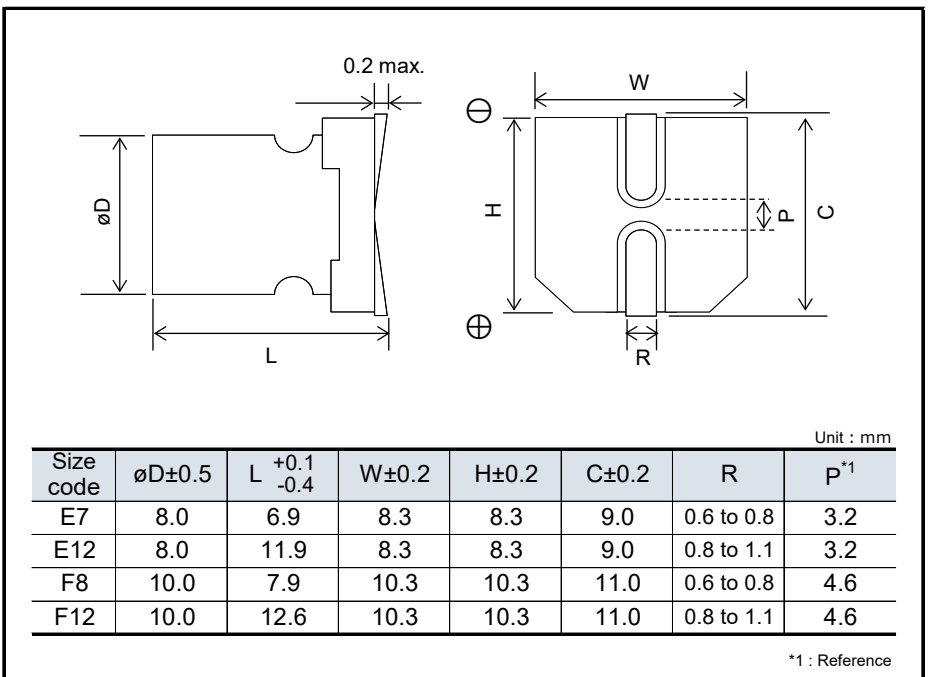

Characteristics list

Rated voltage (V)	Rated capacitance (±20 %) (μF)	Case size (mm)		Size code	Specifications					Standard (Reel size : ø380)		
		øD	L		Ripple current* ¹ (mA rms)	Allowable ripple current* ¹ (mA rms)	ESR* ² (mΩ max.)	tan δ* ³	LC* ⁴ (μA)	Part number	Min. Packaging Q'ty (pcs)	
63	18	8.0	6.9	E7	340	1100	60	0.12	56	63SXV18M	1000	
	33	8.0	11.9	E12	930	2950	25	0.12	104	63SXV33M	400	
	39	8.0	11.9	E12	930	2950	25	0.12	122	63SXV39M	400	
		10.0	7.9	F8	690	2190	50	0.12	122	63SXV39MX	500	
	56	8.0	11.9	E12	930	2950	25	0.12	176	63SXV56M	400	
	68	8.0	11.9	E12	930	2950	25	0.12	214	63SXV68MX	400	
		10.0	12.6	F12	1030	3280	25	0.12	214	63SXV68M	400	
	NEW	82	8.0	11.9	E12	930	2950	25	0.12	258	63SXV82M	400
		100	10.0	12.6	F12	1030	3280	25	0.12	315	63SXV100M	400
		120	10.0	12.6	F12	1030	3280	25	0.12	378	63SXV120M	400
NEW	150	10.0	12.6	F12	1030	3280	25	0.12	472	63SXV150M	400	
72	82	10.0	12.6	F12	980	3100	28	0.12	295	72SXV82M	400	
	100	10.0	12.6	F12	980	3100	28	0.12	360	72SXV100M	400	
80	12	8.0	6.9	E7	340	1100	60	0.12	48	80SXV12M	1000	
	27	8.0	11.9	E12	780	2490	35	0.12	108	80SXV27M	400	
		10.0	7.9	F8	660	2080	55	0.12	108	80SXV27MX	500	
	33	8.0	11.9	E12	780	2490	35	0.12	132	80SXV33M	400	
	47	8.0	11.9	E12	780	2490	35	0.12	188	80SXV47MX	400	
		10.0	12.6	F12	980	3100	28	0.12	188	80SXV47M	400	
	NEW	56	8.0	11.9	E12	780	2490	35	0.12	224	80SXV56MX	400
			10.0	12.6	F12	980	3100	28	0.12	224	80SXV56M	400
NEW	100	10.0	12.6	F12	980	3100	28	0.12	400	80SXV100M	400	
100	6.8	8.0	6.9	E7	340	1100	60	0.12	34	100SXV6R8M	1000	
	15	10.0	7.9	F8	630	2000	60	0.12	75	100SXV15MX	500	
		8.0	11.9	E12	730	2350	40	0.12	75	100SXV15M	400	
	18	10.0	12.6	F12	940	3000	30	0.12	90	100SXV18M	400	
		8.0	11.9	E12	730	2350	40	0.12	90	100SXV18MX	400	
	22	10.0	12.6	F12	940	3000	30	0.12	110	100SXV22M	400	
	27	8.0	11.9	E12	730	2350	40	0.12	135	100SXV27MX	400	
		10.0	12.6	F12	940	3000	30	0.12	135	100SXV27M	400	
	39	10.0	12.6	F12	940	3000	30	0.12	195	100SXV39M	400	

*1: Ripple current (100 kHz / +105 °C < Tx ≤ +125 °C) / Allowable ripple current (100 kHz / Tx ≤ +105 °C)

*2: ESR (100 kHz to 300 kHz / +20 °C)

*3: tan δ (120 Hz / +20 °C)

*4: After 2 minutes

◆ Please refer to each page in this catalog for "Reflow conditions" and "Taping specifications".

Frequency correction factor for ripple current

Frequency(f)	120 Hz ≤ f < 1 kHz	1 kHz ≤ f < 10 kHz	10 kHz ≤ f < 100 kHz	100 kHz ≤ f < 500 kHz
Coefficient	0.05	0.3	0.7	1

Conductive Polymer Aluminum Solid Capacitors

Surface Mount Type

SVPG series

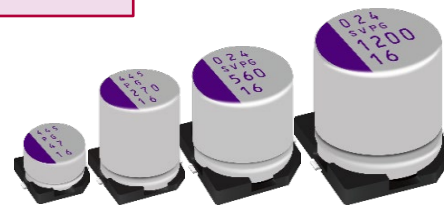

Features

- Low profile (Height 4.5 mm max.)
- Low ESR (6.5 mΩ max.)
- High ripple current (7500 mA rms max.)
- RoHS compliance, Halogen free

Specifications

Size code	B45	B6	C6	C8	C10	C10L	E7	E10	E12	F10	F12
Category temp. range	-55 °C to +105 °C										
Rated voltage range (V)	16 to 25	16	16 ~ 25			16	16 ~ 25	16	16 to 25	16	16 to 25
Nominal cap.range (μF)	15 to 47	100	82 to 220	120 to 270	150 to 270	330	120 to 330	560	270 to 680	820	470 to 1200
Capacitance tolerance	±20 % (120 Hz / +20 °C)										
DC leakage current	Please see the attached characteristics list										
Dissipation factor (tan δ)	Please see the attached characteristics list										
Endurance	+105 °C 5000 h, rated voltage applied										
	Capacitance change	Within ±20 % of the initial value									
	Dissipation factor (tanδ)	≤ 150 % of the initial limit									
	DC leakage current	Within the initial limit									
Damp heat (Steady state)	+60 °C, 90 % to 95 % RH, 1000 h, No-applied voltage										
	Capacitance change	Within ±20 % of the initial value									
	Dissipation factor (tanδ)	≤ 150 % of the initial limit									
	DC leakage current	Within the initial limit (after voltage processing)									

Marking

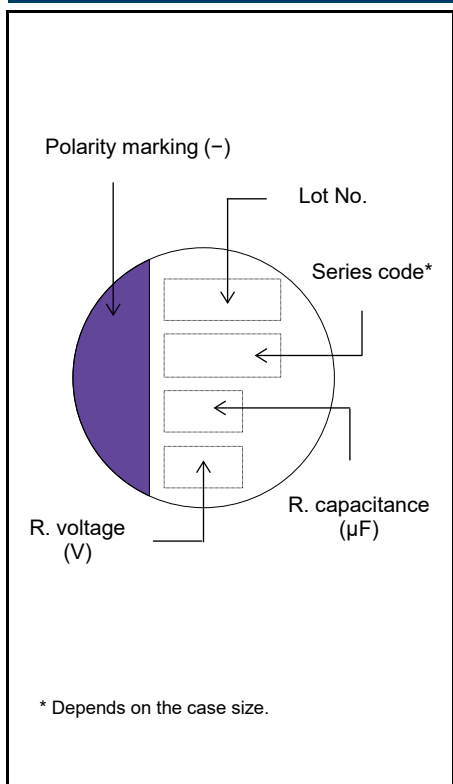

Dimensions (not to scale)

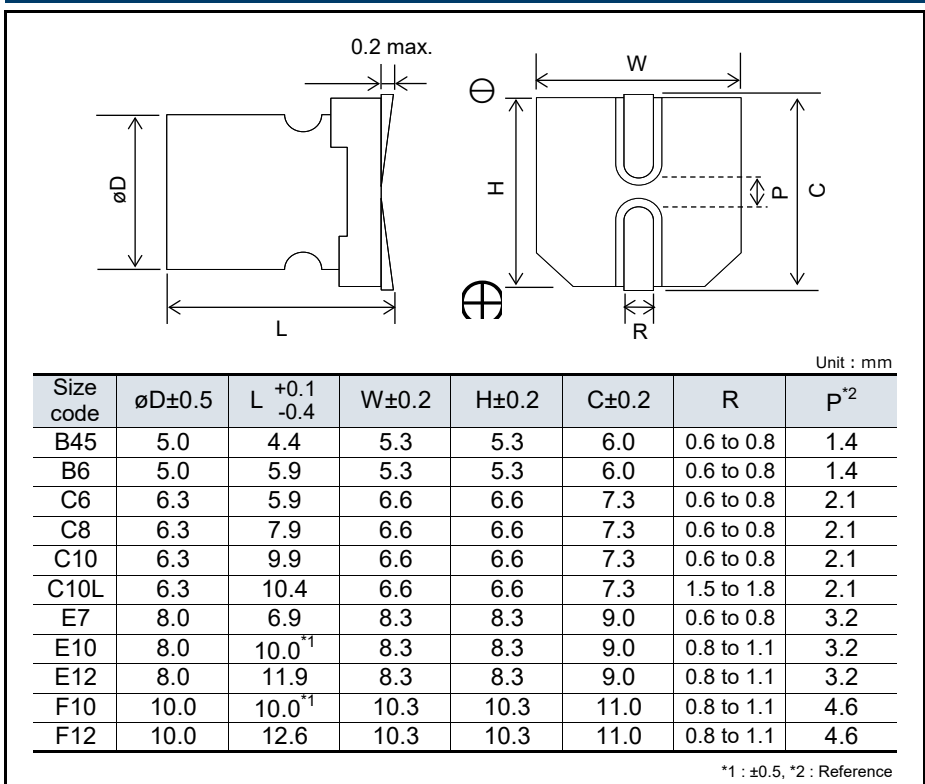

Characteristics list

Rated voltage (V)	Rated capacitance (±20 %) (μF)	Case size (mm)		Size code	Specifications				Standard (Reel size : ø380)	
		øD	L		Ripple current* ¹ (mA rms)	ESR* ² (mΩ max.)	tan δ* ³	LC* ⁴ (μA)	Part number	Min. Packaging Q'ty (pcs)
16	47	5.0	4.4	B45	3200	25	0.12	150	16SVPG47M	2500
	100	5.0	5.9	B6	4000	15	0.12	320	16SVPG100M	1500
	220	6.3	5.9	C6	4100	14	0.12	704	16SVPG220M	1000
	270	6.3	7.9	C8	5080	10	0.12	864	16SVPG270MX	900
		6.3	9.9	C10	5800	8	0.12	864	16SVPG270M	500
	330	6.3	10.4	C10L	7500	6.5	0.12	1056	16SVPG330M	700
		8.0	6.9	E7	4100	16	0.12	1056	16SVPG330MX	1000
	560	8.0	10.0	E10	5200	10	0.12	1792	16SVPG560M	500
	680	8.0	11.9	E12	6500	8	0.12	2176	16SVPG680M	400
820	10.0	10.0	F10	5700	9	0.12	2624	16SVPG820M	500	
1200	10.0	12.6	F12	7000	7	0.12	3840	16SVPG1200M	400	
20	33	5.0	4.4	B45	3000	27	0.12	132	20SVPG33M	2500
	120	6.3	5.9	C6	3750	18	0.12	480	20SVPG120M	1000
	180	6.3	7.9	C8	4200	14	0.12	720	20SVPG180MX	900
		6.3	9.9	C10	4700	11	0.12	720	20SVPG180M	500
	220	8.0	6.9	E7	3750	18	0.12	880	20SVPG220M	1000
	470	8.0	11.9	E12	5850	10	0.12	1880	20SVPG470M	400
	680	10.0	12.6	F12	6200	9	0.12	2720	20SVPG680M	400
25	NRFND 15	5.0	4.4	B45	2800	30	0.12	75	25SVPG15M	2500
	82	6.3	5.9	C6	3750	18	0.12	410	25SVPG82M	1000
	120	6.3	7.9	C8	3900	15	0.12	600	25SVPG120MX	900
		8.0	6.9	E7	3800	17	0.12	600	25SVPG120M	1000
	150	6.3	9.9	C10	4200	13	0.12	750	25SVPG150M	500
	270	8.0	11.9	E12	5350	12	0.12	1350	25SVPG270M	400
	470	10.0	12.6	F12	5900	10	0.12	2350	25SVPG470M	400

*1: Ripple current (100 kHz / +105 °C)

*2: ESR (100 kHz to 300 kHz / +20 °C)

NRFND Not recommended for new design

*3: tan δ (120 Hz / +20 °C)

*4: After 2 minutes

◆ Please refer to each page in this catalog for "Reflow conditions" and "Taping specifications".

Frequency correction factor for ripple current

Frequency(f)	120 Hz ≤ f < 1 kHz	1 kHz ≤ f < 10 kHz	10 kHz ≤ f < 100 kHz	100 kHz ≤ f < 500 kHz
Coefficient	0.05	0.3	0.7	1

**Conductive Polymer Aluminum
Solid Capacitors**
Surface Mount Type
SVPF series

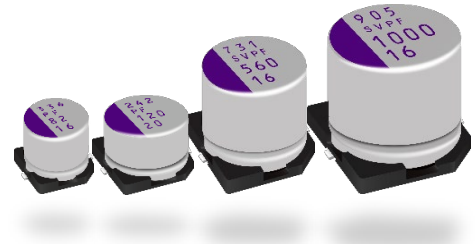

Features

- High voltage (50 V max.)
- Large capacitance (1000 µF max.)
- 105 °C 5000 h
- RoHS compliance, Halogen free

Specifications

Size code	B6	C6	E7	E10	E12	F10	F12
Category temp. range	-55 °C to +105 °C						
Rated voltage range (V)	16 to 25	16 to 50		16	16 to 50	16	16 to 50
Nominal cap.range (µF)	27 to 82	10 to 180	18 to 270	560	39 to 560	1000	68 to 1000
Capacitance tolerance	±20 % (120 Hz / +20 °C)						
DC leakage current	Please see the attached characteristics list						
Dissipation factor (tan δ)	Please see the attached characteristics list						
Endurance	+105 °C 5000 h, rated voltage applied						
	Capacitance change	Within ±20 % of the initial value					
	Dissipation factor (tanδ)	≤ 150 % of the initial limit					
	DC leakage current	Within the initial limit					
Damp heat (Steady state)	+60 °C, 90 % to 95 % RH, 1000 h, No-applied voltage						
	Capacitance change	Within ±20 % of the initial value					
	Dissipation factor (tanδ)	≤ 150 % of the initial limit					
	DC leakage current	Within the initial limit (after voltage processing)					

Marking

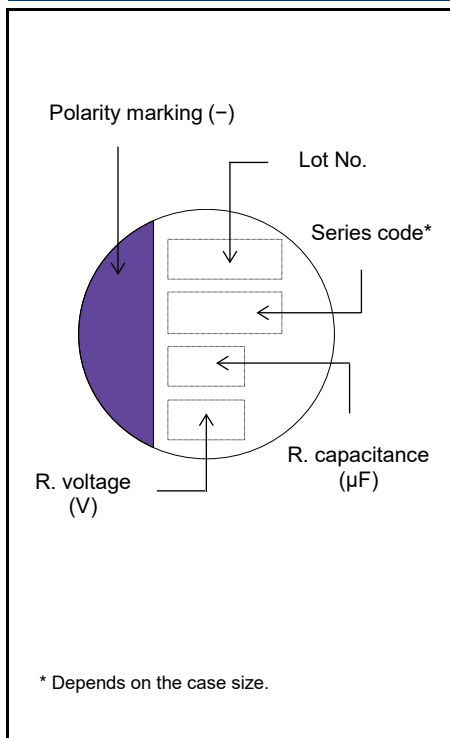

Dimensions (not to scale)

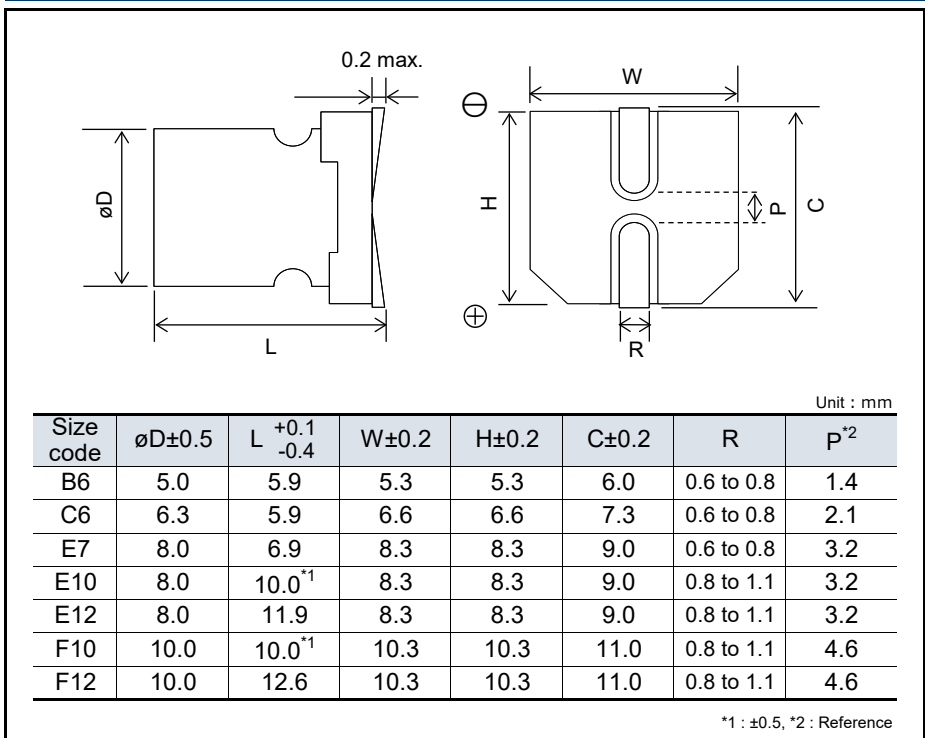

Characteristics list

Rated voltage (V)	Rated capacitance (±20 %) (μF)	Case size (mm)		Size code	Specifications				Standard (Reel size : ø380)	
		øD	L		Ripple current* ¹ (mA rms)	ESR* ² (mΩ max.)	tan δ* ³	LC* ⁴ (μA)	Part number	Min. Packaging Q'ty (pcs)
16	82	5.0	5.9	B6	3000	27	0.12	262	16SVPF82M	1500
	180	6.3	5.9	C6	3300	22	0.12	576	16SVPF180M	1000
	270	8.0	6.9	E7	3300	22	0.12	864	16SVPF270M	1000
	560	8.0	10.0	E10	3900	18	0.12	1792	16SVPF560MX	500
		8.0	11.9	E12	4950	14	0.12	1792	16SVPF560M	400
	1000	10.0	10.0	F10	4300	16	0.12	3200	16SVPF1000MX	500
10.0		12.6	F12	5400	12	0.12	3200	16SVPF1000M	400	
20	56	5.0	5.9	B6	2800	30	0.12	224	20SVPF56MX	1500
	120	6.3	5.9	C6	3200	25	0.12	480	20SVPF120M	1000
	180	8.0	6.9	E7	3200	25	0.12	720	20SVPF180M	1000
	390	8.0	11.9	E12	4950	14	0.12	1560	20SVPF390M	400
	560	10.0	12.6	F12	5400	12	0.12	2240	20SVPF560M	400
25	27	5.0	5.9	B6	2450	40	0.12	135	25SVPF27MX	1500
	47	6.3	5.9	C6	2800	30	0.12	235	25SVPF47M	1000
	56	6.3	5.9		2800	30	0.12	280	25SVPF56M	1000
	82	8.0	6.9	E7	3000	28	0.12	410	25SVPF82M	1000
	100	8.0	6.9		3200	24	0.12	500	25SVPF100M	1000
	180	8.0	11.9	E12	4650	16	0.12	900	25SVPF180M	400
	330	10.0	12.6	F12	5000	14	0.12	1650	25SVPF330M	400
35	22	6.3	5.9	C6	2600	35	0.12	154	35SVPF22M	1000
	39	8.0	6.9	E7	2800	30	0.12	273	35SVPF39M	1000
	82	8.0	11.9	E12	4000	20	0.12	574	35SVPF82M	400
	120	10.0	12.6	F12	4400	18	0.12	840	35SVPF120M	400
50	10	6.3	5.9	C6	2500	40	0.12	100	50SVPF10M	1000
	18	8.0	6.9	E7	2700	35	0.12	180	50SVPF18M	1000
	39	8.0	11.9	E12	3800	25	0.12	390	50SVPF39M	400
	68	10.0	12.6	F12	4300	20	0.12	680	50SVPF68M	400

*1: Ripple current (100 kHz / +105 °C)

*2: ESR (100 kHz to 300 kHz / +20 °C)

*3: tan δ (120 Hz / +20 °C)

*4: After 2 minutes

◆ Please refer to each page in this catalog for "Reflow conditions" and "Taping specifications".

Frequency correction factor for ripple current

Frequency(f)	120 Hz ≤ f < 1 kHz	1 kHz ≤ f < 10 kHz	10 kHz ≤ f < 100 kHz	100 kHz ≤ f < 500 kHz
Coefficient	0.05	0.3	0.7	1

Conductive Polymer Aluminum
Solid Capacitors
Surface Mount Type
SVPA series

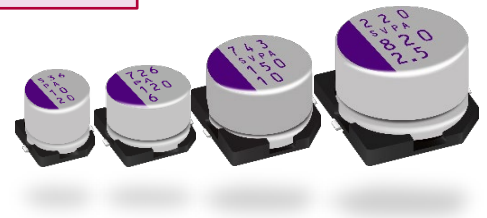

Features

- Low ESR (19 mΩ max.)
- High ripple (4240 mA rms)
- RoHS compliance, Halogen free

Specifications

Size code	B6	C6	E7	F8
Category temp. range	-55 °C to +105 °C			
Rated voltage range	2.5 V to 20 V			2.5 V to 16 V
Nominal cap.range	10 μF to 82 μF	22 μF to 180 μF	47 μF to 330 μF	180 μF to 820 μF
Capacitance tolerance	±20 % (120 Hz / +20 °C)			
DC leakage current	Please see the attached characteristics list			
Dissipation factor (tan δ)	Please see the attached characteristics list			
Endurance	+105 °C 2000 h, rated voltage applied			
	Capacitance change	Within ±20 % of the initial value		
	Dissipation factor (tanδ)	≤ 150 % of the initial limit		
	DC leakage current	Within the initial limit		
Damp heat (Steady state)	+60 °C, 90 % to 95 % RH, 1000 h, No-applied voltage			
	Capacitance change	Within ±20 % of the initial value		
	Dissipation factor (tanδ)	≤ 150 % of the initial limit		
	DC leakage current	Within the initial limit (after voltage processing)		

Marking

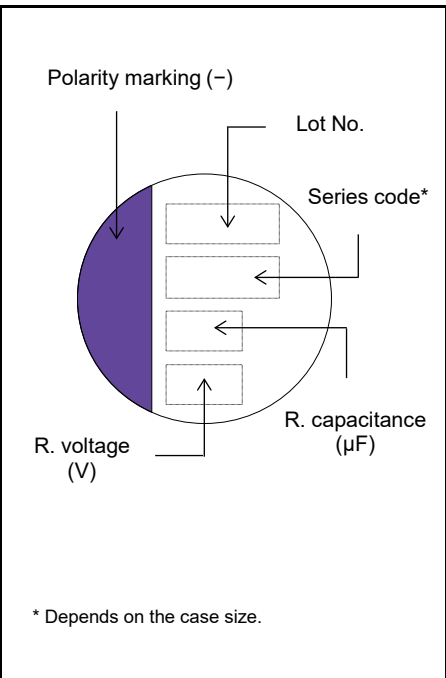

Dimensions (not to scale)

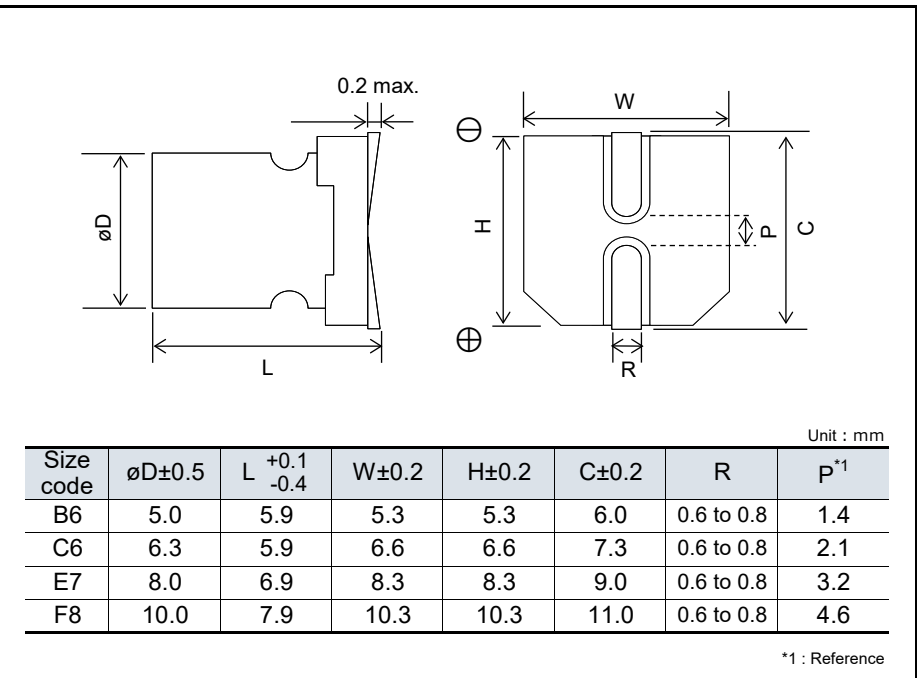

Characteristics list

Rated voltage (V)	Rated capacitance (±20 %) (μF)	Case size (mm)		Size code	Specifications				Standard (Reel size : ø380)	
		øD	L		Ripple current* ¹ (mA rms)	ESR* ² (mΩ max.)	tan δ* ³	LC* ⁴ (μA)	Part number	Min. Packaging Qty (pcs)
2.5	NRFND 82	5.0	5.9	B6	1970	30	0.12	300	2R5SVPA82MAA	1500
	NRFND 180	6.3	5.9	C6	2690	20	0.12	300	2R5SVPA180MAA	1000
	NRFND 330	8.0	6.9	E7	3370	20	0.12	500	2R5SVPA330MAA	1000
	820	10.0	7.9	F8	4240	19	0.12	500	2R5SVPA820M	500
4.0	NRFND 68	5.0	5.9	B6	1970	30	0.12	300	4SVPA68MAA	1500
	NRFND 150	6.3	5.9	C6	2570	22	0.12	300	4SVPA150MAA	1000
	270	8.0	6.9	E7	3220	22	0.12	500	4SVPA270MAA	1000
	680	10.0	7.9	F8	4130	20	0.12	544	4SVPA680M	500
6.3	47	5.0	5.9	B6	1970	30	0.12	300	6SVPA47MAA	1500
	120	6.3	5.9	C6	2570	22	0.12	300	6SVPA120MAA	1000
	220	8.0	6.9	E7	3220	22	0.12	500	6SVPA220MAA	1000
	470	10.0	7.9	F8	4130	20	0.12	592	6SVPA470M	500
10	68	6.3	5.9	C6	2200	30	0.12	300	10SVPA68MAA	1000
	150	8.0	6.9	E7	2760	30	0.12	500	10SVPA150MAA	1000
	330	10.0	7.9	F8	3770	24	0.12	660	10SVPA330M	500
16	39	6.3	5.9	C6	2040	35	0.12	300	16SVPA39MAA	1000
		6.3	5.9		2460	24	0.12	300	16SVPA39MAAY	1000
	82	8.0	6.9	E7	2760	30	0.12	262	16SVPA82MAA	1000
	180	10.0	7.9	F8	3430	29	0.12	576	16SVPA180M	500
20	10	5.0	5.9	B6	1700	40	0.12	80	20SVPA10M	1500
	22	6.3	5.9	C6	2040	35	0.12	88	20SVPA22M	1000
	47	8.0	6.9	E7	2630	33	0.12	188	20SVPA47M	1000

*1: Ripple current (100 kHz / +105 °C)

NRFND

Not recommended for new design

*2: ESR (100 kHz / +20 °C)

*3: tan δ (120 Hz / +20 °C)

*4: After 2 minutes

◆ Please refer to each page in this catalog for "Reflow conditions" and "Taping specifications".

Frequency correction factor for ripple current

Frequency(f)	120 Hz ≤ f < 1 kHz	1 kHz ≤ f < 10 kHz	10 kHz ≤ f < 100 kHz	100 kHz ≤ f < 500 kHz
Coefficient	0.05	0.3	0.7	1

**Conductive Polymer Aluminum
Solid Capacitors**
Surface Mount Type
SVPC series

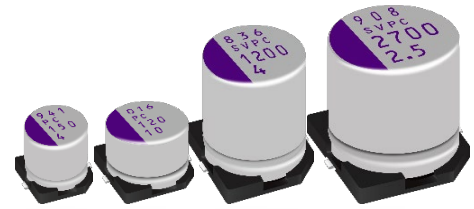

Features

- Low ESR (9 mΩ max.)
- Large capacitance (2700 μF max.)
- RoHS compliance, Halogen free

Specifications

Size code	B6	C6	E7	E12	F12
Category temp. range	-55 °C to +105 °C				
Rated voltage range	2.5 V to 16 V				2.5 V
Nominal cap.range	39 μF to 180 μF	68 μF to 560 μF	120 μF to 680 μF	270 μF to 1500 μF	2700 μF
Capacitance tolerance	±20 % (120 Hz / +20 °C)				
DC leakage current	Please see the attached characteristics list				
Dissipation factor (tan δ)	Please see the attached characteristics list				
Endurance	+105 °C 2000 h, rated voltage applied				
	Capacitance change	Within ±20 % of the initial value			
	Dissipation factor (tanδ)	≤ 150 % of the initial limit			
	DC leakage current	Within the initial limit			
Damp heat (Steady state)	+60 °C, 90 % to 95 % RH, 1000 h, No-applied voltage				
	Capacitance change	Within ±20 % of the initial value			
	Dissipation factor (tanδ)	≤ 150 % of the initial limit			
	DC leakage current	Within the initial limit (after voltage processing)			

Marking

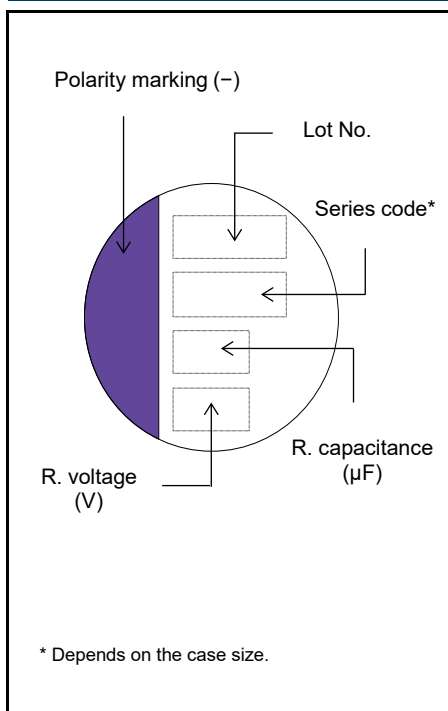

Dimensions (not to scale)

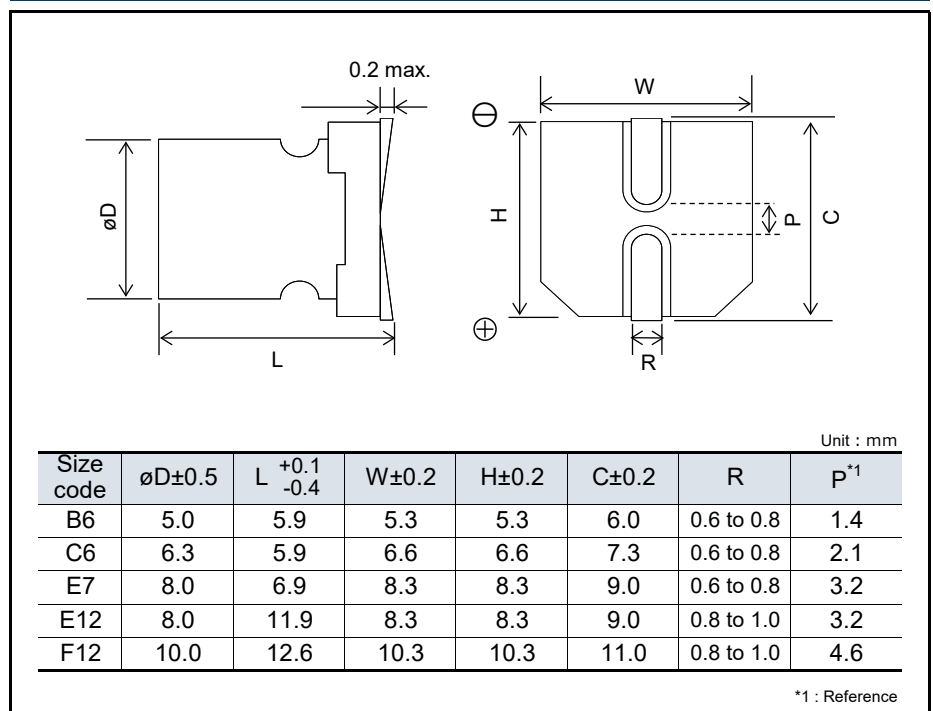

Characteristics list

Rated voltage (V)	Rated capacitance ($\pm 20\%$) (μF)	Case size (mm)		Size code	Specifications					Standard (Reel size : $\phi 380$)	
		ϕD	L		Ripple current ^{*1} (mA rms)	ESR (m Ω max.)		$\tan \delta$ ^{*3}	LC ^{*4} (μA)	Part number	Min. Packaging Qty (pcs)
						100 kHz / 20 °C	300 kHz ^{*2} / 20 °C				
2.5	180	5.0	5.9	B6	1970	30	26	0.12	300	2R5SVPC180M	1500
		5.0	5.9		2200	24	20	0.12	300	2R5SVPC180MY	1500
		5.0	5.9		2800	19	16	0.12	300	2R5SVPC180MV	1500
	390	6.3	5.9	C6	2410	25	22	0.12	300	2R5SVPC390M	1000
		6.3	5.9		3160	15	13	0.12	300	2R5SVPC390MV	1000
		6.3	5.9		3500	16	14	0.12	300	2R5SVPC560M	1000
	680	8.0	6.9	E7	3370	20	17	0.12	500	2R5SVPC680M	1000
	820	8.0	11.9	E12	5380	9	8	0.15	500	2R5SVPC820M	400
	1500	8.0	11.9		5150	10	9	0.15	750	2R5SVPC1500M	400
2700	10.0	12.6	F12	5070	12	10	0.15	1350	2R5SVPC2700M	400	
4.0	150	5.0	5.9	B6	1970	30	26	0.12	300	4SVPC150M	1500
		5.0	5.9		2240	23	20	0.12	300	4SVPC150MY	1500
		5.0	5.9		2730	20	17	0.12	300	4SVPC150MV	1500
	330	6.3	5.9	C6	2320	27	23	0.12	300	4SVPC330M	1000
		6.3	5.9		2630	21	18	0.12	300	4SVPC330MY	1000
		6.3	5.9		3160	15	13	0.12	300	4SVPC330MV	1000
	560	8.0	6.9	E7	3220	22	19	0.12	500	4SVPC560M	1000
		8.0	11.9	E12	5380	9	8	0.15	500	4SVPC560MX	400
	1200	8.0	11.9		4700	12	10	0.15	960	4SVPC1200M	400
1500	8.0	11.9	4700		12	10	0.15	1200	4SVPC1500M	400	
6.3	100	5.0	5.9	B6	1970	30	26	0.12	300	6SVPC100M	1500
		5.0	5.9		2150	25	21	0.12	300	6SVPC100MY	1500
	120	5.0	5.9	C6	2660	21	18	0.12	300	6SVPC120MV	1500
	220	6.3	5.9		2320	27	23	0.12	300	6SVPC220M	1000
		6.3	5.9		3160	15	13	0.12	300	6SVPC220MV	1000
	330	6.3	5.9	3390	17	15	0.12	415	6SVPC330M	1000	
	390	8.0	6.9	E7	3220	22	19	0.12	491	6SVPC390M	1000
820	8.0	11.9	E12	4700	12	10	0.15	1033	6SVPC820M	400	
10	68	5.0	5.9	B6	1970	30	26	0.12	300	10SVPC68M	1500
		5.0	5.9		2540	23	20	0.12	300	10SVPC68MV	1500
	120	6.3	5.9	C6	2320	27	23	0.12	300	10SVPC120M	1000
		6.3	5.9		2600	22	19	0.12	300	10SVPC120MV	1000
	270	8.0	6.9	E7	3220	22	19	0.12	500	10SVPC270M	1000
330	8.0	6.9	E7	3460	19	17	0.12	660	10SVPC330M	1000	
16	39	5.0	5.9	B6	1820	35	30	0.12	300	16SVPC39M	1500
		5.0	5.9		2350	27	23	0.12	300	16SVPC39MV	1500
	68	6.3	5.9	C6	2200	30	26	0.12	300	16SVPC68M	1000
		6.3	5.9		2440	25	22	0.12	300	16SVPC68MV	1000
	100	6.3	5.9	2490	24	23	0.12	300	16SVPC100M	1000	
	120	8.0	6.9	E7	2900	27	23	0.12	500	16SVPC120M	1000
	150	8.0	6.9		3220	22	21	0.12	500	16SVPC150M	1000
	270	8.0	11.9	E12	4070	16	14	0.15	864	16SVPC270M	400

*1: Ripple current (100 kHz / +105 °C) *2: Reference value at 300 kHz *3: $\tan \delta$ (120 Hz / +20 °C) *4: After 2 minutes

◆ Please refer to each page in this catalog for "Reflow conditions" and "Taping specifications".

Frequency correction factor for ripple current

Frequency(f)	120 Hz \leq f < 1 kHz	1 kHz \leq f < 10 kHz	10 kHz \leq f < 100 kHz	100 kHz \leq f < 500 kHz
Coefficient	0.05	0.3	0.7	1

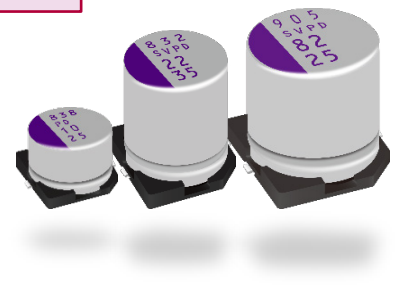

Conductive Polymer Aluminum Solid Capacitors

Surface Mount Type

SVPD series

Features

- 125 °C 2000 h
- Guaranteed at 85 °C 85 %
- RoHS compliance, Halogen free

Specifications

Size code	C6	E7	E12	F8	F12
Category temp. range	-55 °C to +125 °C				
Rated voltage range	10 V to 25 V	16 V to 35 V	25 V to 35 V		
Nominal cap.range	10 μF to 56 μF	8.2 μF to 82 μF	22 μF to 47 μF	18 μF to 39 μF	47 μF to 82 μF
Capacitance tolerance	±20 % (120 Hz / +20 °C)				
DC leakage current	Please see the attached characteristics list				
Dissipation factor (tan δ)	Please see the attached characteristics list				
Endurance	+125 °C 2000 h, rated voltage applied				
	Capacitance change	Within ±20 % of the initial value			
	Dissipation factor (tanδ)	≤ 200 % of the initial limit			
	DC leakage current	Within the initial limit			
Damp heat (Steady state)	+85 °C, 80 % to 90 % RH, 1000 h, rated voltage applied.				
	Capacitance change	Within ±20 % of the initial value			
	Dissipation factor (tanδ)	≤ 200 % of the initial limit			
	DC leakage current	Within the initial limit (after voltage processing)			

Marking

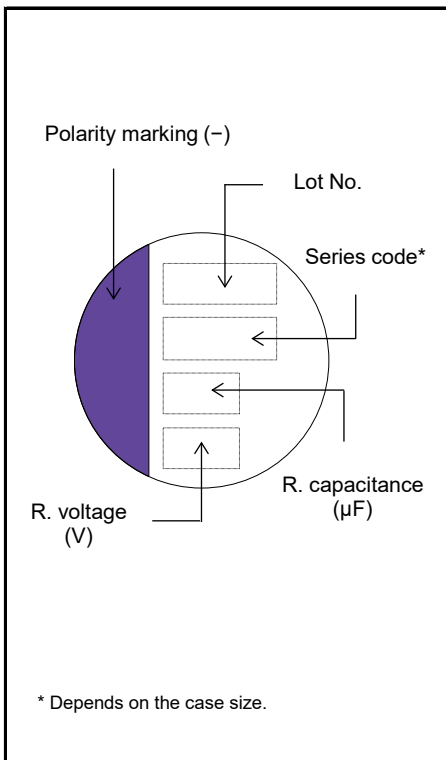

Dimensions (not to scale)

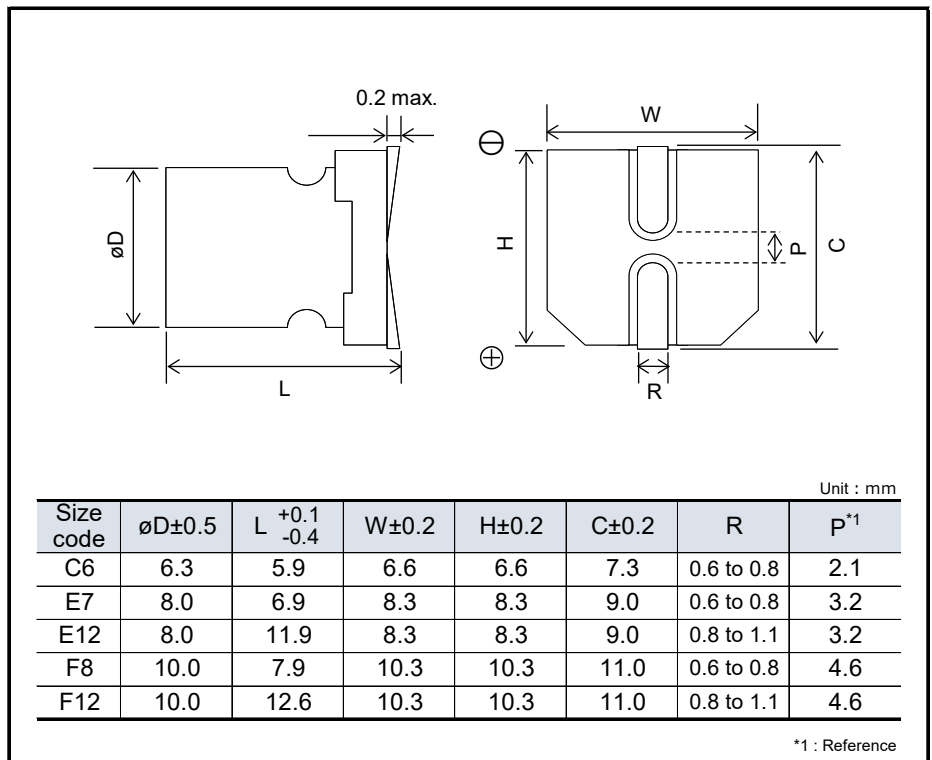

Characteristics list

Rated voltage (V)	Rated capacitance ($\pm 20\%$) (μF)	Case size (mm)		Size code	Specifications					Standard (Reel size : $\phi 380$)	
		ϕD	L		Ripple current* ¹ (mA rms)	Allowable ripple current* ¹ (mA rms)	ESR* ² (m Ω max.)	$\tan \delta$ * ³	LC* ⁴ (μA)	Part number	Min. Packaging Qty (pcs)
10	56	6.3	5.9	C6	538	1700	45	0.12	112	10SVPD56M	1000
16	82	8.0	6.9	E7	670	2120	40	0.12	262	16SVPD82M	1000
25	10	6.3	5.9	C6	474	1500	65	0.10	50	25SVPD10M	1000
	22	8.0	6.9	E7	580	1835	48	0.10	110	25SVPD22M	1000
	39	10.0	7.9	F8	664	2100	45	0.10	195	25SVPD39M	500
	47	8.0	11.9	E12	943	2980	30	0.12	235	25SVPD47M	400
	82	10.0	12.6	F12	1202	3800	28	0.12	410	25SVPD82M	400
35	NRFND 8.2	8.0	6.9	E7	400	1300	70	0.10	57	35SVPD8R2M	1000
	18	10.0	7.9	F8	550	1800	60	0.10	126	35SVPD18M	500
	22	8.0	11.9	E12	700	2300	50	0.12	154	35SVPD22M	400
	47	10.0	12.6	F12	1150	3650	30	0.12	329	35SVPD47M	400

*1: Ripple current (100 kHz / $+105\text{ }^\circ\text{C} < T_x \leq +125\text{ }^\circ\text{C}$), Allowable ripple current (100 kHz / $T_x \leq +105\text{ }^\circ\text{C}$)

*2: ESR (100 kHz to 300 kHz / $+20\text{ }^\circ\text{C}$)

NRFND Not recommended for new design

*3: $\tan \delta$ (120 Hz / $+20\text{ }^\circ\text{C}$)

*4: After 2 minutes

◆ Please refer to each page in this catalog for "Reflow conditions" and "Taping specifications".

Frequency correction factor for ripple current

Frequency(f)	$120\text{ Hz} \leq f < 1\text{ kHz}$	$1\text{ kHz} \leq f < 10\text{ kHz}$	$10\text{ kHz} \leq f < 100\text{ kHz}$	$100\text{ kHz} \leq f < 500\text{ kHz}$
Coefficient	0.05	0.3	0.7	1

Conductive Polymer Aluminum
Solid Capacitors
Surface Mount Type
SVPE series

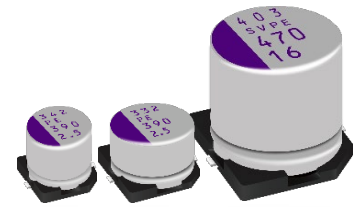

Features

- Low ESR (8 mΩ max.)
- Large capacitance (1200 μF max.)
- RoHS compliance, Halogen free

Specifications

Size code	B6	C6	C10	F12
Category temp. range	-55 °C to +105 °C			
Rated voltage range	2.5 V to 6.3 V	2.5 V to 10 V	2.0 V to 16 V	16 V
Nominal cap.range	150 μF to 390 μF	220 μF to 820 μF	180 μF to 1200 μF	470 μF
Capacitance tolerance	±20 % (120 Hz / +20 °C)			
DC leakage current	Please see the attached characteristics list			
Dissipation factor (tan δ)	Please see the attached characteristics list			
Endurance	+105 °C 2000 h, rated voltage applied			
	Capacitance change	Within ±20 % of the initial value		
	Dissipation factor (tanδ)	≤ 150 % of the initial limit		
	DC leakage current	Within the initial limit		
Damp heat (Steady state)	+60 °C, 90 % to 95 % RH, 1000 h, No-applied voltage			
	Capacitance change	Within ±20 % of the initial value		
	Dissipation factor (tanδ)	≤ 150 % of the initial limit		
	DC leakage current	Within the initial limit (after voltage processing)		

Marking

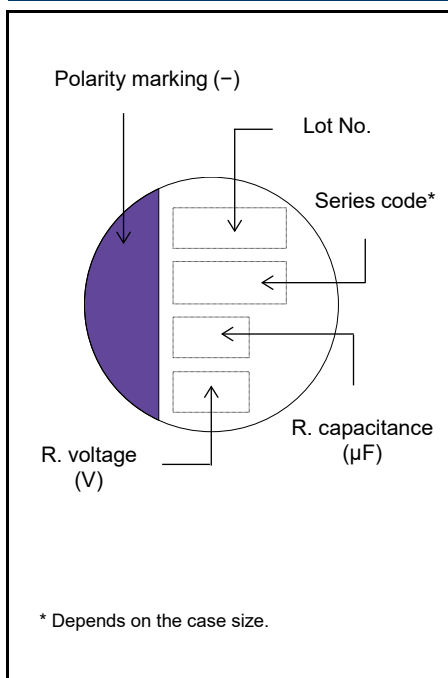

Dimensions (not to scale)

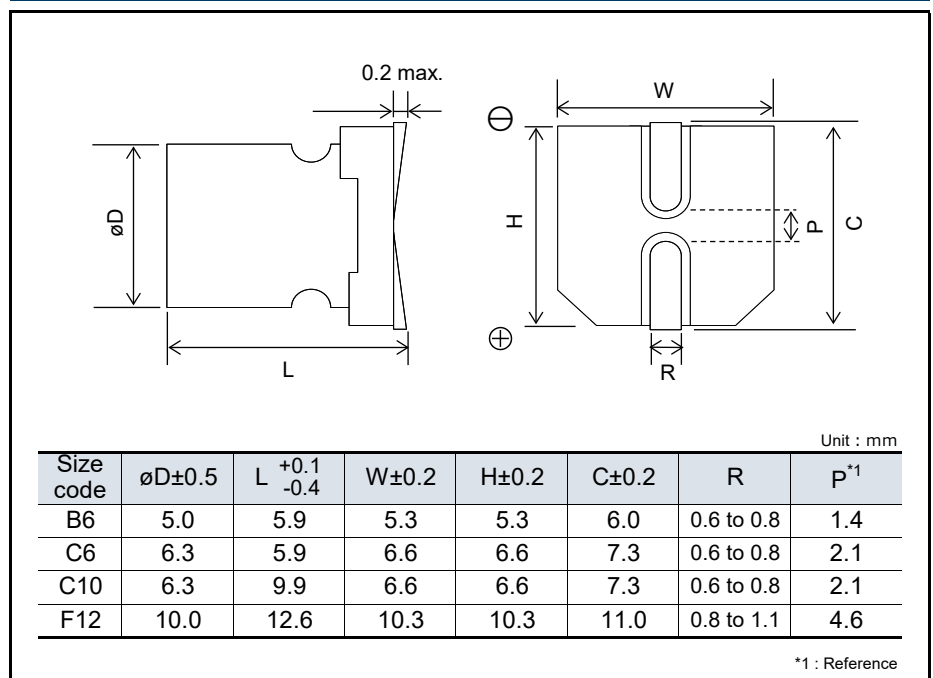

Characteristics list

Rated voltage (V)	Rated capacitance ($\pm 20\%$) (μF)	Case size (mm)		Size code	Specifications					Standard (Reel size : $\phi 380$)	
		ϕD	L		Ripple current ^{*1} (mA rms)	ESR (m Ω max.)		$\tan \delta$ ^{*3}	LC ^{*4} (μA)	Part number	Min. Packaging Qty (pcs)
						100 kHz / 20 °C	300 kHz ^{*2} / 20 °C				
2.0	1200	6.3	9.9	C10	5230	8	8	0.12	500	2SVPE1200M	500
2.5	270	5.0	5.9	B6	3860	10	9	0.12	500	2R5SVPE270M	1500
	330	5.0	5.9		3150	15	13	0.12	500	2R5SVPE330M	1500
		5.0	5.9		3860	10	9	0.12	500	2R5SVPE330MY	1500
	390	5.0	5.9		3860	10	9	0.12	700	2R5SVPE390MX	1500
		6.3	5.9	C6	3900	10	9	0.12	500	2R5SVPE390M	1000
	820	6.3	5.9	3900	10	9	0.12	1020	2R5SVPE820M	1000	
6.3	150	5.0	5.9	B6	3520	12	10	0.12	500	6SVPE150M	1500
	180	5.0	5.9		3150	15	13	0.12	500	6SVPE180M	1500
	220	5.0	5.9		3150	15	13	0.12	500	6SVPE220MW	1500
		6.3	5.9	3900	10	9	0.12	500	6SVPE220M	1000	
	390	6.3	5.9	C6	3900	10	9	0.12	1220	6SVPE390M	1000
10	220	6.3	5.9		2700	20	18	0.12	500	10SVPE220M	1000
16	180	6.3	9.9	C10	4460	11	10	0.12	576	16SVPE180M	500
	470	10.0	12.6	F12	6100	10	9	0.12	1504	16SVPE470M	400

*1: Ripple current (100 kHz / +105 °C)

*2: Reference value at 300 kHz

*3: $\tan \delta$ (120 Hz / +20 °C)

*4: After 2 minutes

◆ Please refer to each page in this catalog for "Reflow conditions" and "Taping specifications".

Frequency correction factor for ripple current

Frequency(f)	120 Hz \leq f < 1 kHz	1 kHz \leq f < 10 kHz	10 kHz \leq f < 100 kHz	100 kHz \leq f < 500 kHz
Coefficient	0.05	0.3	0.7	1



Conductive Polymer Aluminum Solid Capacitors

Surface Mount Type

SVPS series



Features

- 105 °C 5000 h
- RoHS compliance, Halogen free

Specifications

Size code	A5	B6	C6	E7	F8
Category temp. range	-55 °C to +105 °C				
Rated voltage range	4.0 V to 10 V	4.0 V to 16 V	4.0 V to 20 V	4.0 V to 25 V	4.0 V to 16 V
Nominal cap.range	10 μF to 33 μF	22 μF to 68 μF	22 μF to 150 μF	10 μF to 270 μF	100 μF to 680 μF
Capacitance tolerance	±20 % (120 Hz / +20 °C)				
DC leakage current	Please see the attached characteristics list				
Dissipation factor (tan δ)	Please see the attached characteristics list				
Endurance	+105 °C 5000 h, rated voltage applied (25 V product : 20 V applied)				
	Capacitance change	Within ±20 % of the initial value			
	Dissipation factor (tanδ)	≤ 150 % of the initial limit			
	DC leakage current	Within the initial limit			
Damp heat (Steady state)	+60 °C, 90 % to 95 % RH, 1000 h, No-applied voltage				
	Capacitance change	Within ±20 % of the initial value			
	Dissipation factor (tanδ)	≤ 150 % of the initial limit			
	DC leakage current	Within the initial limit (after voltage processing)			

Marking

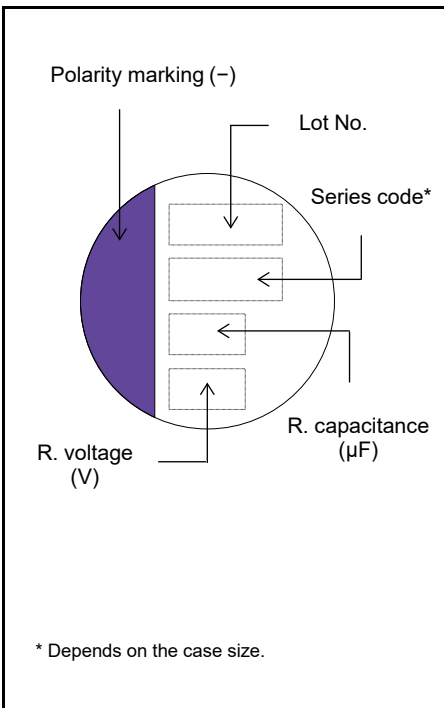

Dimensions (not to scale)

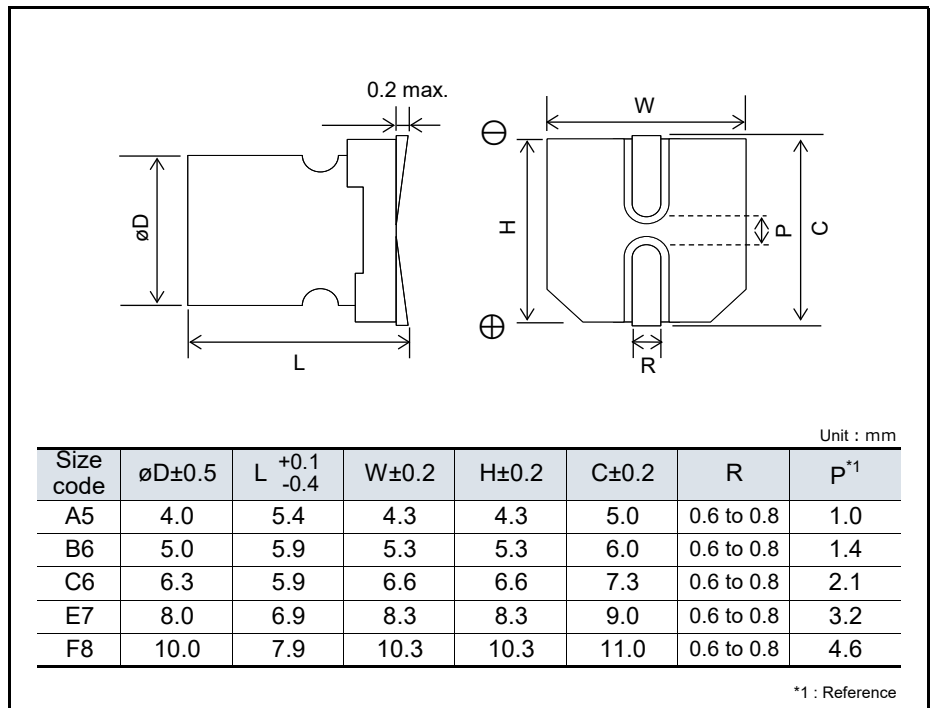

Characteristics list

Rated voltage (V)	Rated capacitance (±20 %) (μF)	Case size (mm)		Size code	Specifications				Standard (Reel size : ø380)	
		øD	L		Ripple current* ¹ (mA rms)	ESR* ² (mΩ max.)	tan δ* ³	LC* ⁴ (μA)	Part number	Min. Packaging Qty (pcs)
4.0	NRFND 33	4.0	5.4	A5	740	200	0.15	66	4SVPS33M	2000
	NRFND 68	5.0	5.9	B6	1970	30	0.12	300	4SVPS68M	1500
	150	6.3	5.9	C6	2570	22	0.12	300	4SVPS150M	1000
	NRFND 270	8.0	6.9	E7	3220	22	0.12	500	4SVPS270M	1000
	680	10.0	7.9	F8	4130	20	0.12	544	4SVPS680M	500
6.3	NRFND 22	4.0	5.4	A5	740	200	0.12	69.3	6SVPS22M	2000
	47	5.0	5.9	B6	1970	30	0.12	300	6SVPS47M	1500
	120	6.3	5.9	C6	2570	22	0.12	300	6SVPS120M	1000
	220	8.0	6.9	E7	3220	22	0.12	500	6SVPS220M	1000
	470	10.0	7.9	F8	4130	20	0.12	592	6SVPS470M	500
10	NRFND 10	4.0	5.4	A5	700	220	0.10	50	10SVPS10M	2000
	NRFND 15	4.0	5.4		740	200	0.10	75	10SVPS15M	2000
	33	5.0	5.9	B6	1100	70	0.12	165	10SVPS33M	1500
	68	6.3	5.9	C6	2200	30	0.12	300	10SVPS68M	1000
	150	8.0	6.9	F8	2760	30	0.12	500	10SVPS150MX	1000
		10.0	7.9		3020	30	0.12	300	10SVPS150M	500
	330	10.0	7.9		3770	24	0.12	660	10SVPS330M	500
16	22	5.0	5.9	B6	1060	90	0.10	176	16SVPS22M	1500
	39	6.3	5.9	C6	2460	24	0.12	300	16SVPS39M	1000
	82	8.0	6.9	E7	2760	30	0.12	262	16SVPS82M	1000
	100	10.0	7.9	F8	2670	35	0.12	320	16SVPS100M	500
		180	10.0		7.9	3430	29	0.12	576	16SVPS180M
20	22	6.3	5.9	C6	1450	60	0.10	88	20SVPS22M	1000
	47	8.0	6.9	E7	1890	45	0.12	188	20SVPS47M	1000
25	10	8.0	6.9	E7	1500	60	0.10	125	25SVPS10M	1000

*1: Ripple current (100 kHz / +105 °C)

NRFND

Not recommended for new design

: The surface temperature of aluminum case top must not exceed 105 °C.

A rise in temperature due to self-heating by ripple current should be factored in.

*2: ESR (100 kHz to 300 kHz / +20 °C)

*3: tan δ (120 Hz / +20 °C)

*4: After 2 minutes

◆ Please refer to each page in this catalog for "Reflow conditions" and "Taping specifications".

Frequency correction factor for ripple current

Frequency(f)	120 Hz ≤ f < 1 kHz	1 kHz ≤ f < 10 kHz	10 kHz ≤ f < 100 kHz	100 kHz ≤ f < 500 kHz
Coefficient	0.05	0.3	0.7	1



Conductive Polymer Aluminum Solid Capacitors Surface Mount Type SVQP series

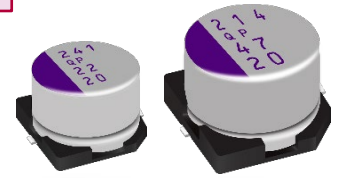

Features

- 125 °C 1000 h
- RoHS compliance, Halogen free

Specifications

Size code	C6	E7
Category temp. range	-55 °C to +125 °C	
Rated voltage range	4.0 V to 20 V	6.3 V to 20 V
Nominal cap.range	22 μF to 150 μF	47 μF to 220 μF
Capacitance tolerance	±20 % (120 Hz / +20 °C)	
DC leakage current	Please see the attached characteristics list	
Dissipation factor (tan δ)	Please see the attached characteristics list	
Endurance	+125 °C 1000 h, rated voltage applied	
	Capacitance change	Within ±20 % of the initial value
	Dissipation factor (tanδ)	≤ 200 % of the initial limit
	DC leakage current	Within the initial limit
Damp heat (Steady state)	+60 °C, 90 % to 95 % RH, 1000 h, No-applied voltage	
	Capacitance change	Within ±20 % of the initial value
	Dissipation factor (tanδ)	≤ 150 % of the initial limit
	DC leakage current	Within the initial limit (after voltage processing)

Marking

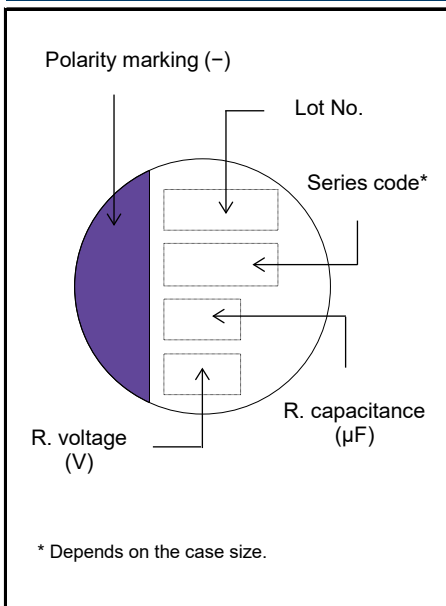

Dimensions (not to scale)

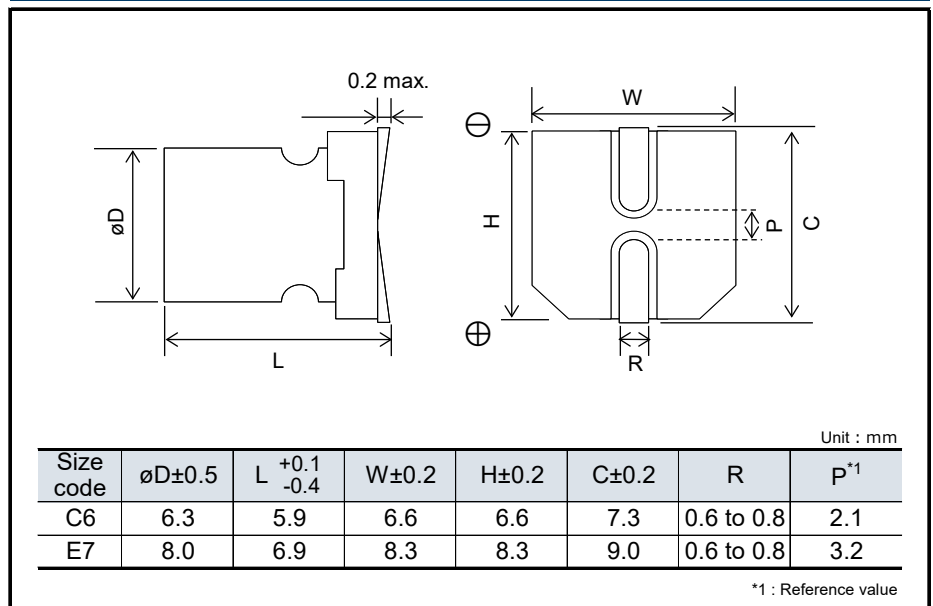

Characteristics list

Rated voltage (V)	Rated capacitance ($\pm 20\%$) (μF)	Case size (mm)		Size code	Specifications					Standard (Reel size : $\phi 380$)	
		ϕD	L		Ripple current ^{*1} (mA rms)	Allowable ripple current ^{*1} (mA rms)	ESR ^{*2} (m Ω max.)	$\tan \delta$ ^{*3}	LC ^{*4} (μA)	Part number	Min. Packaging Qty (pcs)
4.0	150	6.3	5.9	C6	572	1810	40	0.12	300	4SVQP150M	1000
	NRFND 82	6.3	5.9		538	1700	45	0.12	258	6SVQP82M	1000
6.3	100	6.3	5.9	E7	572	1810	40	0.12	315	6SVQP100M	1000
	220	8.0	6.9		810	2560	35	0.12	693	6SVQP220M	1000
10	56	6.3	5.9	C6	538	1700	45	0.12	280	10SVQP56M	1000
	120	8.0	6.9	E7	810	2560	35	0.12	600	10SVQP120M	1000
	150	8.0	6.9		810	2560	35	0.12	750	10SVQP150M	1000
16	39	6.3	5.9	C6	512	1620	50	0.10	312	16SVQP39M	1000
	82	8.0	6.9	E7	670	2120	40	0.12	656	16SVQP82M	1000
20	22	6.3	5.9	C6	459	1450	60	0.10	220	20SVQP22M	1000
	47	8.3	6.9	E7	598	1890	45	0.12	470	20SVQP47M	1000

*1: Ripple current (100 kHz / $+105^\circ\text{C} < \text{Tx} \leq +125^\circ\text{C}$), Allowable ripple current (100 kHz / $\text{Tx} \leq +105^\circ\text{C}$)

NRFND Not recommended for new design

*2: ESR (100 kHz to 300 kHz / $+20^\circ\text{C}$)

*3: $\tan \delta$ (120 Hz / $+20^\circ\text{C}$)

*4: After 2 minutes

◆ Please refer to each page in this catalog for "Reflow conditions" and "Taping specifications".

Frequency correction factor for ripple current

Frequency(f)	120 Hz $\leq f < 1$ kHz	1 kHz $\leq f < 10$ kHz	10 kHz $\leq f < 100$ kHz	100 kHz $\leq f < 500$ kHz
Coefficient	0.05	0.3	0.7	1

Conductive Polymer Aluminum Solid Capacitors

Surface Mount Type

SVP series



Features

- Standard
- RoHS compliance, Halogen free

Specifications

Size code	A5	B6	C6	E7	E12	F8	F12
Category temp. range	-55 °C to +105 °C						
Rated voltage range (V)	4.0 to 16	4.0 to 20	2.5 to 20	4.0 to 20	2.5 to 20	4.0 to 20	2.5 to 20
Nominal cap.range (µF)	3.3 to 33	10 to 68	22 to 220	33 to 330	100 to 680	56 to 680	150 to 1500
Capacitance tolerance	±20 % (120 Hz / +20 °C)						
DC leakage current	Please see the attached characteristics list						
Dissipation factor (tan δ)	Please see the attached characteristics list						
Endurance	+105 °C 2000 h, rated voltage applied						
	Capacitance change	Within ±20 % of the initial value					
	Dissipation factor (tanδ)	≤ 150 % of the initial limit					
	DC leakage current	Within the initial limit					
Damp heat (Steady state)	+60 °C, 90 % to 95 % RH, 1000 h, No-applied voltage						
	Capacitance change	Within ±20 % of the initial value					
	Dissipation factor (tanδ)	≤ 150 % of the initial limit					
	DC leakage current	Within the initial limit (after voltage processing)					

Marking

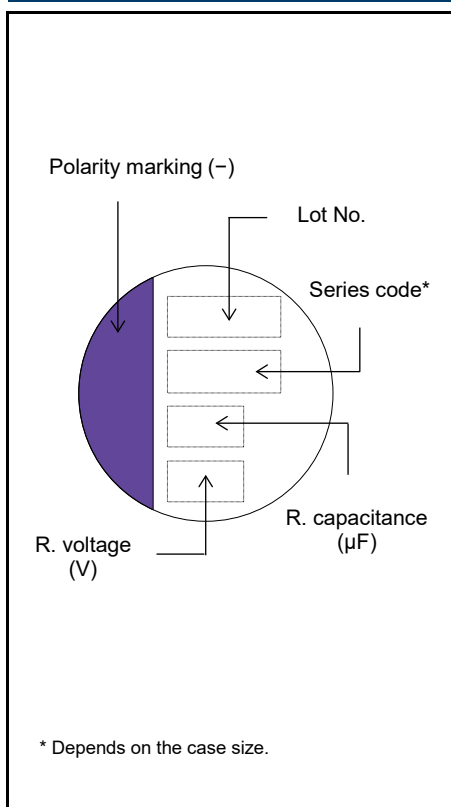

Dimensions (not to scale)

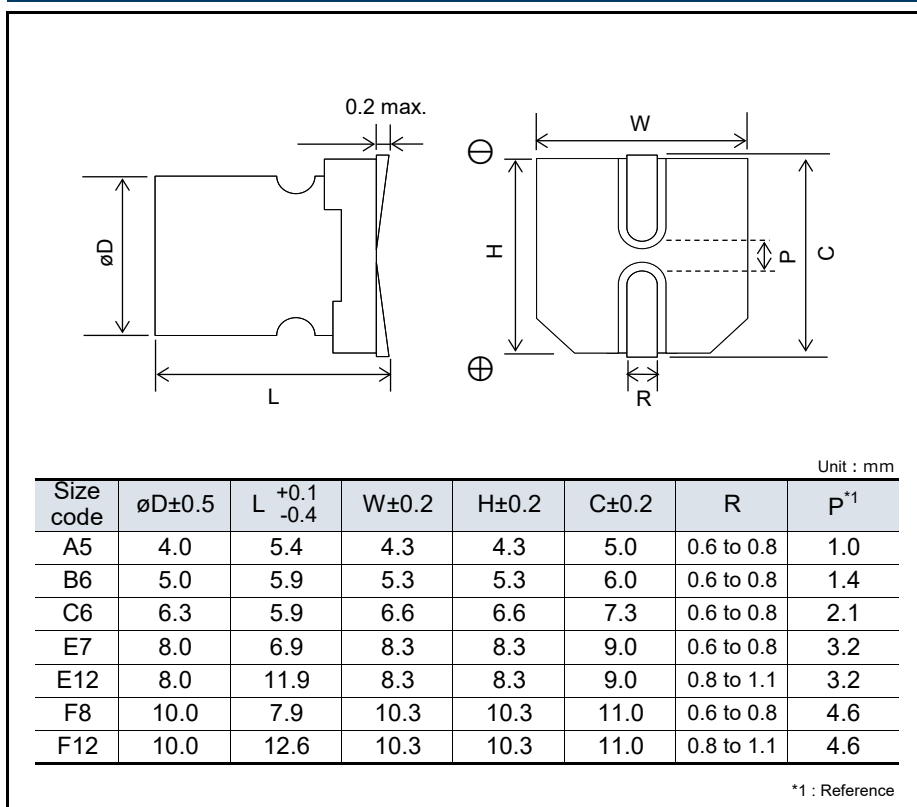

Characteristics list

Rated voltage (V)	Rated capacitance ($\pm 20\%$) (μF)	Case size (mm)		Size code	Specifications				Standard (Reel size : $\phi 380$)	
		ϕD	L		Ripple current ^{*1} (mA rms)	ESR ^{*2} (m Ω max.)	$\tan \delta$ ^{*3}	LC ^{*4} (μA)	Part number	Min. Packaging Qty (pcs)
2.5	220	6.3	5.9	C6	2390	23	0.12	110	2R5SVP220M	1000
	680	8.0	11.9	E12	4520	13	0.15	340	2R5SVP680M	400
	1500	10.0	12.6	F12	5440	12	0.18	750	2R5SVP1500M	400
4.0	NRFND 33	4.0	5.4	A5	740	200	0.15	66	4SVP33M	2000
	NRFND 39	5.0	5.9	B6	1100	70	0.12	78	4SVP39M	1500
	68	5.0	5.9		1400	60	0.12	136	4SVP68M	1500
	150	6.3	5.9	C6	1810	40	0.12	120	4SVP150MX	1000
	330	8.0	6.9	E7	2560	35	0.12	264	4SVP330M	1000
	560	8.0	11.9	E12	4520	13	0.15	448	4SVP560M	400
	680	10.0	7.9	F8	3700	25	0.12	544	4SVP680M	500
	1200	10.0	12.6	F12	5440	12	0.18	960	4SVP1200M	400
6.3	NRFND 22	4.0	5.4	A5	740	200	0.12	69.3	6SVP22M	2000
	47	5.0	5.9	B6	1100	70	0.12	148	6SVP47M	1500
	82	6.3	5.9	C6	1700	45	0.12	103	6SVP82M	1000
	100	6.3	5.9		1810	40	0.12	126	6SVP100M	1000
	120	6.3	5.9	2780	17	0.12	151	6SVP120MV	1000	
	220	8.0	6.9	E7	2560	35	0.12	277	6SVP220MX	1000
	330	10.0	7.9	F8	3700	25	0.12	277	6SVP220M	500
		10.0	7.9		3700	25	0.12	416	6SVP330M	500
	470	10.0	7.9	E12	3700	25	0.12	592	6SVP470MX	500
		8.0	11.9		4210	15	0.15	592	6SVP470M	400
	820	10.0	12.6	F12	5440	12	0.15	775	6SVP820M	400
10	NRFND 4.7	4.0	5.4	A5	670	240	0.08	23.5	10SVP4R7M	2000
	NRFND 6.8	4.0	5.4		670	240	0.09	34	10SVP6R8M	2000
	NRFND 10	4.0	5.4		700	220	0.10	50	10SVP10M	2000
	NRFND 15	4.0	5.4		740	200	0.10	75	10SVP15M	2000
	33	5.0	5.9	B6	1100	70	0.12	165	10SVP33M	1500
	47	6.3	5.9	C6	1620	50	0.12	94	10SVP47M	1000
	56	6.3	5.9		1700	45	0.12	112	10SVP56M	1000
	120	8.0	6.9	E7	2560	35	0.12	240	10SVP120M	1000
	150	8.0	6.9	F8	2560	35	0.12	300	10SVP150MX	1000
		10.0	7.9		3020	30	0.12	300	10SVP150M	500
	270	10.0	7.9	3700	25	0.12	540	10SVP270M	500	
	330	10.0	7.9	E12	3700	25	0.12	660	10SVP330MX	500
		8.0	11.9		3950	17	0.15	660	10SVP330M	400
560	10.0	12.6	F12	5230	13	0.15	840	10SVP560M	400	
16	NRFND 3.3	4.0	5.4	A5	660	260	0.07	26.4	16SVP3R3M	2000
	15	5.0	5.9	B6	1020	120	0.10	120	16SVP15M	1500
	22	5.0	5.9		1060	90	0.10	176	16SVP22M	1500
	39	6.3	5.9	C6	1620	50	0.10	125	16SVP39M	1000
	56	8.0	6.9	E7	1890	45	0.12	179	16SVP56M	1000
	82	8.0	6.9		2120	40	0.12	262	16SVP82M	1000
	100	10.0	7.9	F8	2670	35	0.12	320	16SVP100M	500
	150	10.0	7.9		3020	30	0.12	480	16SVP150M	500
	180	10.0	7.9		3020	30	0.12	576	16SVP180MX	500
		8.0	11.9		E12	3640	20	0.15	576	16SVP180M
	330	10.0	12.6	F12	4720	16	0.15	792	16SVP330M	400
20	10	5.0	5.9	B6	1020	120	0.10	100	20SVP10M	1500
	22	6.3	5.9	C6	1450	60	0.10	88	20SVP22M	1000
	27	6.3	5.9		1450	60	0.10	108	20SVP27M	1000
	33	8.0	6.9	E7	1890	45	0.12	132	20SVP33M	1000
	47	8.0	6.9	F8	1890	45	0.12	188	20SVP47M	1000
	56	10.0	7.9		2400	40	0.12	224	20SVP56M	500
	68	10.0	7.9	2400	40	0.12	272	20SVP68M	500	
	100	8.0	11.9	E12	3320	24	0.15	400	20SVP100M	400
	150	10.0	12.6	F12	4320	20	0.15	600	20SVP150M	400

*1: Ripple current (100 kHz / +105 °C)

*2: ESR (100 kHz to 300 kHz/+20 °C)

*3: $\tan \delta$ (120 Hz / +20 °C)

*4: After 2 minutes

NRFND Not recommended for new design

◆ Please refer to each page in this catalog for "Reflow conditions" and "Taping specifications".

Frequency correction factor for ripple current

Frequency(f)	120 Hz \leq f < 1 kHz	1 kHz \leq f < 10 kHz	10 kHz \leq f < 100 kHz	100 kHz \leq f < 500 kHz
Coefficient	0.05	0.3	0.7	1

Conductive Polymer Aluminum Solid Capacitors Radial Lead Type SEF series



Features

- High voltage (35 V max.)
- Large capacitance (1000 μ F max.)
- RoHS compliance, Halogen free

Specifications

Size code	C6	E7	E12	F13
Category temp. range	-55 °C to +125 °C			
Rated voltage range	16 V to 35 V			
Nominal cap.range	22 μ F to 180 μ F	39 μ F to 270 μ F	82 μ F to 560 μ F	120 μ F to 1000 μ F
Capacitance tolerance	\pm 20 % (120 Hz / +20 °C)			
DC leakage current	Please see the attached characteristics list			
Dissipation factor (tan δ)	Please see the attached characteristics list			
Endurance	+125 °C 1000 h, rated voltage applied			
	Capacitance change	Within \pm 20 % of the initial value		
	Dissipation factor (tan δ)	\leq 200 % of the initial limit		
	DC leakage current	Within the initial limit		
Damp heat (Steady state)	+60 °C, 90 % to 95 % RH, 1000 h, No-applied voltage			
	Capacitance change	Within \pm 20 % of the initial value		
	Dissipation factor (tan δ)	\leq 150 % of the initial limit		
	DC leakage current	Within the initial limit (after voltage processing)		

Marking

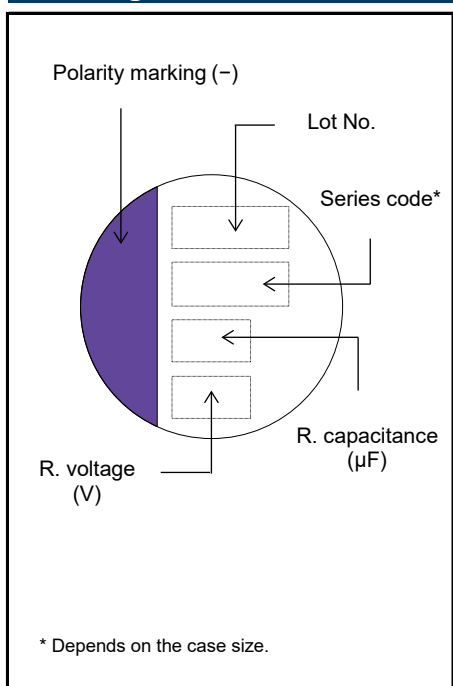

Dimensions (not to scale)

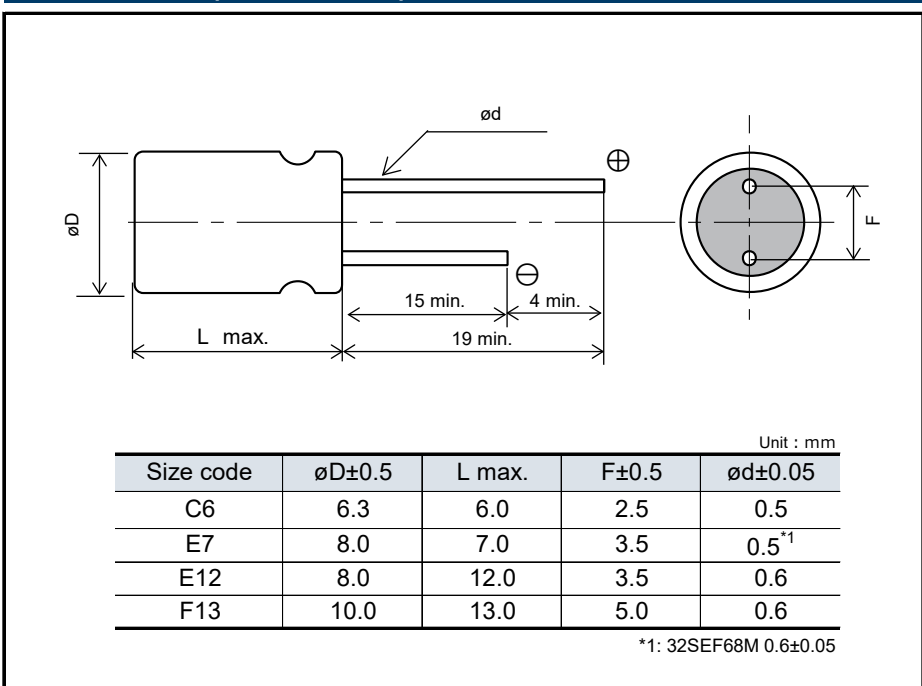

Characteristics list

Rated voltage (V)	Rated capacitance ($\pm 20\%$) (μF)	Case size (mm)		Size code	Specifications					Part number <small>Click here for part number list of lead terminal cutting and lead terminal taping</small>
		$\varnothing\text{D}$	L		Ripple current ^{*1} (mA rms)	Allowable ripple current ^{*1} (mA rms)	ESR ^{*2} (m Ω max.)	$\tan \delta$ ^{*3}	LC ^{*4} (μA)	
16	180	6.3	6.0	C6	1040	3300	22	0.12	576	16SEF180M
	270	8.0	7.0	E7	1040	3300	22	0.12	864	16SEF270M
	560	8.0	12.0	E12	1560	4950	14	0.12	1792	16SEF560M
	1000	10.0	13.0	F13	1700	5400	12	0.12	3200	16SEF1000M
20	120	6.3	6.0	C6	1010	3200	25	0.12	480	20SEF120M
	180	8.0	7.0	E7	1010	3200	25	0.12	720	20SEF180M
	390	8.0	12.0	E12	1560	4950	14	0.12	1560	20SEF390M
	560	10.0	13.0	F13	1700	5400	12	0.12	2240	20SEF560M
25	56	6.3	6.0	C6	880	2800	30	0.12	280	25SEF56M
	82	8.0	7.0	E7	940	3000	28	0.12	410	25SEF82M
	180	8.0	12.0	E12	1470	4650	16	0.12	900	25SEF180M
	330	10.0	13.0	F13	1580	5000	14	0.12	1650	25SEF330M
32	68	8.0	7.0	E7	1010	3200	25	0.10	435	32SEF68M
35	22	6.3	6.0	C6	820	2600	35	0.12	154	35SEF22M
	39	8.0	7.0	E7	880	2800	30	0.12	273	35SEF39M
	82	8.0	12.0	E12	1260	4000	20	0.12	574	35SEF82M
	120	10.0	13.0	F13	1390	4400	18	0.12	840	35SEF120M

*1: Ripple current (100 kHz / +105 °C < Tx ≤ +125 °C) / Allowable ripple current (100 kHz / Tx ≤ +105 °C)

*2: ESR (100 kHz to 300 kHz / +20 °C)

*3: $\tan \delta$ (120 Hz / +20 °C)

*4: After 2 minutes

◆ Please refer to each page in this catalog for "Flow conditions" and "Taping specifications".

Frequency correction factor for ripple current

Frequency(f)	120 Hz ≤ f < 1 kHz	1 kHz ≤ f < 10 kHz	10 kHz ≤ f < 100 kHz	100 kHz ≤ f < 500 kHz
Coefficient	0.05	0.3	0.7	1



Conductive Polymer Aluminum Solid Capacitors Radial Lead Type SEK series

Features

- High voltage (50 V max.)
- 125 °C 1000 h
- RoHS compliance, Halogen free

Specifications

Size code	C6	E7	E12	F13
Category temp. range	-55 °C to +125 °C			
Rated voltage range	25 V to 50 V			
Nominal cap.range	22 µF to 82 µF	33 µF to 120 µF	68 µF to 270 µF	120 µF to 470 µF
Capacitance tolerance	±20 % (120 Hz / +20 °C)			
DC leakage current	Please see the attached characteristics list			
Dissipation factor (tan δ)	Please see the attached characteristics list			
Endurance	+125 °C 1000 h, rated voltage applied			
	Capacitance change	Within ±20 % of the initial value		
	Dissipation factor (tanδ)	≤ 200 % of the initial limit		
	DC leakage current	Within the initial limit		
Damp heat (Steady state)	+60 °C, 90 % to 95 % RH, 1000 h, No-applied voltage			
	Capacitance change	Within ±20 % of the initial value		
	Dissipation factor (tanδ)	≤ 150 % of the initial limit		
	DC leakage current	Within the initial limit (after voltage processing)		

Marking

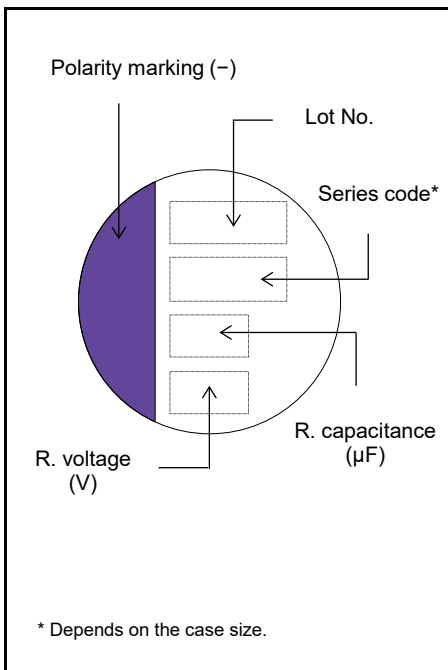

Dimensions (not to scale)

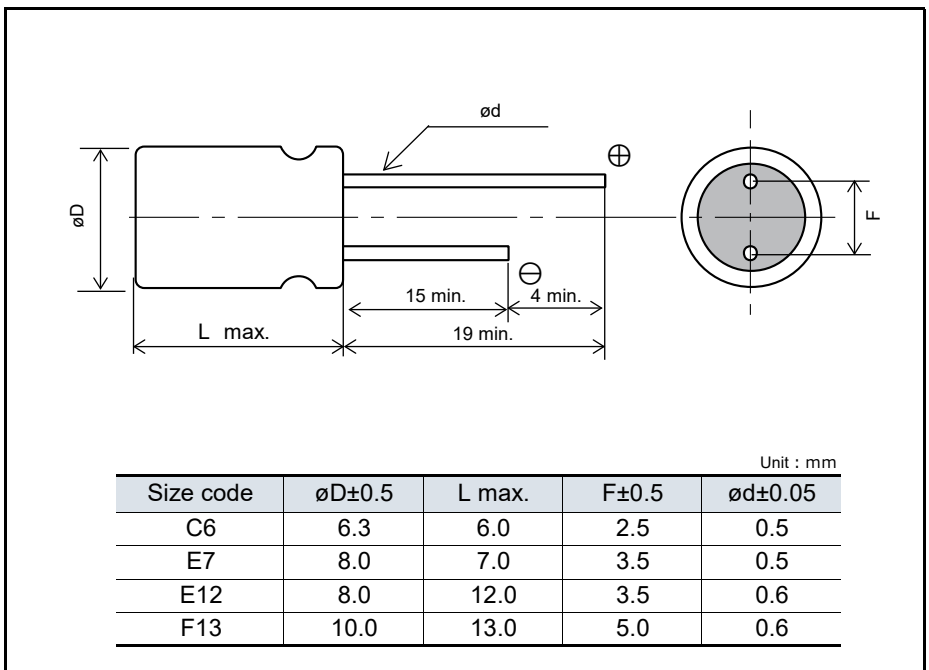

Characteristics list

Rated voltage (V)	Rated capacitance ($\pm 20\%$) (μF)	Case size (mm)		Size code	Specifications					Part number Click here for part number list of lead terminal cutting and lead terminal taping
		$\varnothing\text{D}$	L		Ripple current ^{*1} (mA rms)	Allowable ripple current ^{*1} (mA rms)	ESR ^{*2} (m Ω max.)	$\tan \delta$ ^{*3}	LC ^{*4} (μA)	
25	82	6.3	6.0	C6	960	3060	25	0.12	410	25SEK82M
	120	8.0	7.0	E7	1010	3200	24	0.12	600	25SEK120M
	270	8.0	12.0	E12	1470	4650	16	0.12	1350	25SEK270M
	470	10.0	13.0	F13	1590	5000	14	0.12	2350	25SEK470M
35	47	6.3	6.0	C6	930	2950	27	0.12	329	35SEK47M
	82	8.0	7.0	E7	960	3060	25	0.12	574	35SEK82M
	180	8.0	12.0	E12	1260	4000	20	0.12	1260	35SEK180M
	330	10.0	13.0	F13	1390	4400	18	0.12	2310	35SEK330M
50	22	6.3	6.0	C6	820	2600	35	0.12	220	50SEK22M
	33	8.0	7.0	E7	850	2700	35	0.12	330	50SEK33M
	68	8.0	12.0	E12	1200	3800	25	0.12	680	50SEK68M
	120	10.0	13.0	F13	1350	4300	20	0.12	1200	50SEK120M

*1: Ripple current (100 kHz / +105 °C < Tx \leq +125 °C) / Allowable ripple current (100 kHz / Tx \leq +105 °C)

*2: ESR (100 kHz to 300 kHz / +20 °C)

*3: $\tan \delta$ (120 Hz / +20 °C)

*4: After 2 minutes

◆ Please refer to each page in this catalog for "Flow conditions" and "Taping specifications".

Frequency correction factor for ripple current

Frequency(f)	120 Hz \leq f < 1 kHz	1 kHz \leq f < 10 kHz	10 kHz \leq f < 100 kHz	100 kHz \leq f < 500 kHz
Coefficient	0.05	0.3	0.7	1

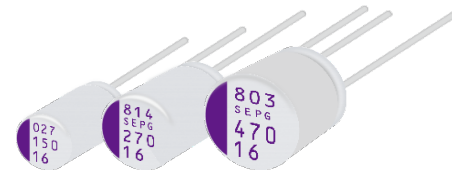

Conductive Polymer Aluminum Solid Capacitors

Radial Lead Type

SEPG series

Features

- High ripple current (6100 mA rms max.)
- RoHS compliance, Halogen free

Specifications

Size code	B9	C9	C10	E9	E13
Category temp. range	-55 °C to +105 °C				
Rated voltage range	16 V				
Rated cap. range	150 μF	270 μF		470 μF	560 μF
Capacitance tolerance	±20 % (120 Hz / +20 °C)				
Leakage current	Please see the attached characteristics list				
Dissipation factor (tan δ)	Please see the attached characteristics list				
Endurance	+105 °C 5000 h, rated voltage applied				
	Capacitance change	Within ±20 % of the initial value			
	Dissipation factor (tan δ)	≤ 200 % of the initial limit			
	DC leakage current	Within the initial limit			
Damp heat (Steady State)	+60 °C, 90 % to 95 % RH, 1000 h, No-applied voltage				
	Capacitance change	Within ±20 % of the initial value			
	Dissipation factor (tan δ)	≤ 150 % of the initial limit			
	DC leakage current	Within the initial limit (after voltage processing)			

Marking

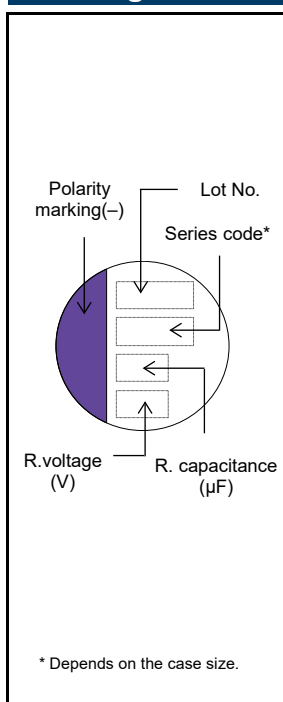

Dimensions (not to scale)

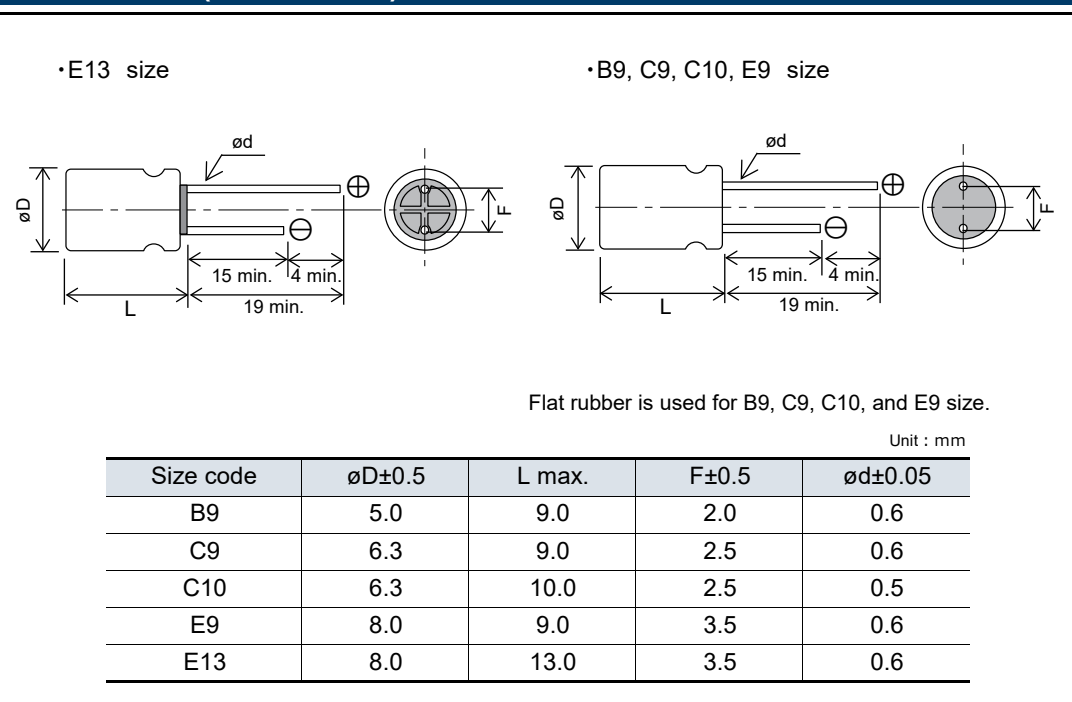

Characteristics list

Rated voltage (V)	Rated capacitance ($\pm 20\%$) (μF)	Case size (mm)		Size code	Specifications				Part number <small>Click here for part number list of lead terminal cutting and lead terminal taping</small>
		$\varnothing\text{D}$	L		Ripple current ^{*1} (mA rms)	ESR ^{*2} (m Ω max.)	$\tan \delta$ ^{*3}	LC ^{*4} (μA)	
16	150	5.0	9.0	B9	4500	12	0.12	480	16SEPG150M
	270	6.3	9.0	C9	5040	10	0.12	864	16SEPG270W
		6.3	10.0	C10	5800	8	0.12	864	16SEPG270M
	470	8.0	9.0	E9	5400	8	0.12	1504	16SEPG470M
	560	8.0	13.0	E13	6100	8	0.12	1792	16SEPG560M

*1: Ripple current (100 kHz / +105 °C)

*2: ESR (100 kHz / +20 °C)

*3: $\tan \delta$ (120 Hz / +20 °C)

*4: After 2 minutes

◆ Please refer to each page in this catalog for "Flow conditions" and "Taping specifications".

Frequency correction factor for ripple current

Frequency(f)	120 Hz \leq f < 1 kHz	1 kHz \leq f < 10 kHz	10 kHz \leq f < 100 kHz	100 kHz \leq f < 500 kHz
Coefficient	0.05	0.3	0.7	1

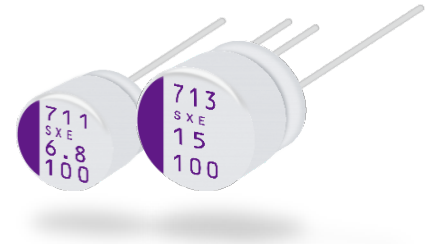

Conductive Polymer Aluminum Solid Capacitors Radial Lead Type SXE series

Features

- Super high voltage (100 V max.)
- 125 °C 1000 h
- RoHS compliance, Halogen free

Specifications

Size code	E7	E12	F8	F13
Category temp. range	-55 °C to +125 °C			
Rated voltage range	63 V to 100 V			
Nominal cap.range	6.8 μF to 18 μF	15 μF to 68 μF	15 μF to 39 μF	18 μF to 120 μF
Capacitance tolerance	±20 % (120 Hz / +20 °C)			
DC leakage current	Please see the attached characteristics list			
Dissipation factor (tan δ)	Please see the attached characteristics list			
Endurance	+125 °C 1000 h, rated voltage applied			
	Capacitance change	Within ±20 % of the initial value		
	Dissipation factor (tanδ)	≤ 200 % of the initial limit		
	DC leakage current	Within the initial limit		
Damp heat (Steady state)	+60 °C, 90 % to 95 % RH, 1000 h, No-applied voltage			
	Capacitance change	Within ±20 % of the initial value		
	Dissipation factor (tanδ)	≤ 150 % of the initial limit		
	DC leakage current	Within the initial limit (after voltage processing)		

Marking

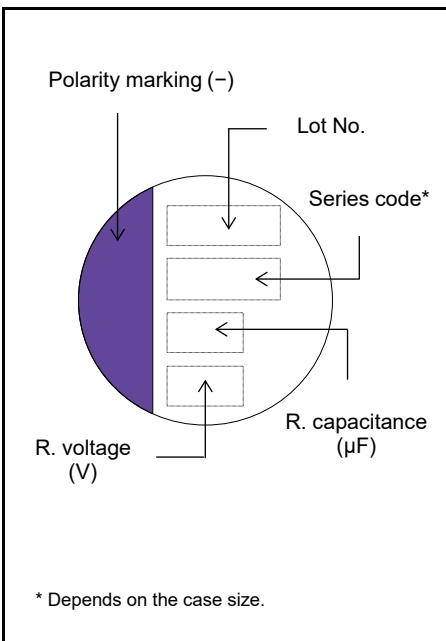

Dimensions (not to scale)

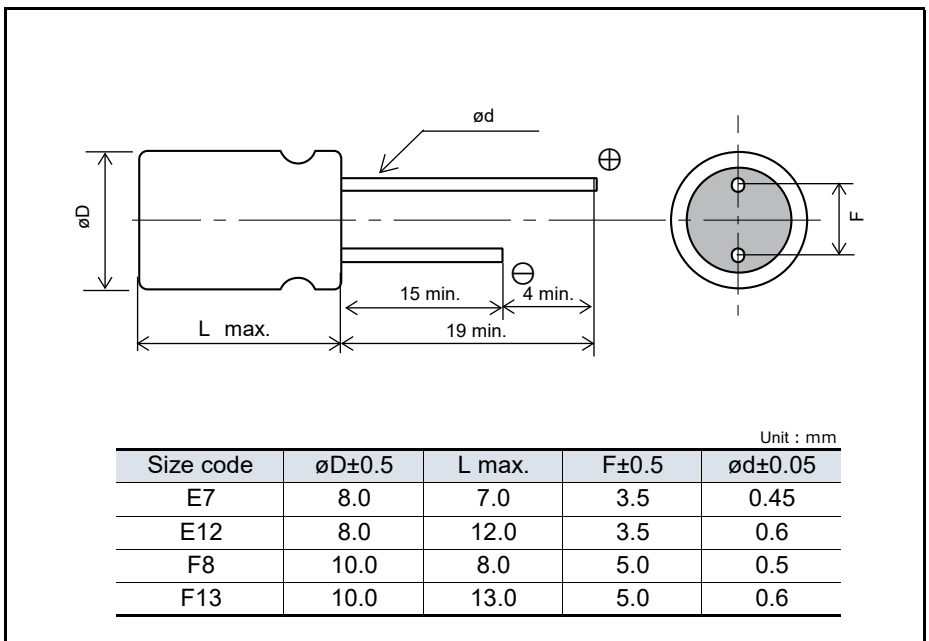

Characteristics list

Rated voltage (V)	Rated capacitance (±20 %) (μF)	Case size (mm)		Size code	Specifications					Part number Click here for part number list of lead terminal cutting and lead terminal taping
		øD	L		Ripple current* ¹ (mA rms)	Allowable ripple current* ¹ (mA rms)	ESR* ² (mΩ max.)	tan δ* ³	LC* ⁴ (μA)	
63	18	8.0	7.0	E7	340	1100	60	0.12	56	63SXE18M
	33	8.0	12.0	E12	930	2950	25	0.12	104	63SXE33M
	39	8.0	12.0	E12	930	2950	25	0.12	122	63SXE39M
		10.0	8.0	F8	690	2190	50	0.12	122	63SXE39MX
	56	8.0	12.0	E12	930	2950	25	0.12	176	63SXE56M
	68	8.0	12.0	E12	930	2950	25	0.12	214	63SXE68MX
		10.0	13.0	F13	1030	3280	25	0.12	214	63SXE68M
	100	10.0	13.0	F13	1030	3280	25	0.12	315	63SXE100M
120	10.0	13.0	F13	1030	3280	25	0.12	378	63SXE120M	
72	82	10.0	13.0	F13	980	3100	28	0.12	295	72SXE82M
	100	10.0	13.0	F13	980	3100	28	0.12	360	72SXE100M
80	12	8.0	7.0	E7	340	1100	60	0.12	48	80SXE12M
	27	8.0	12.0	E12	780	2490	35	0.12	108	80SXE27M
		10.0	8.0	F8	660	2080	55	0.12	108	80SXE27MX
	33	8.0	12.0	E12	780	2490	35	0.12	132	80SXE33M
	47	8.0	12.0	E12	780	2490	35	0.12	188	80SXE47MX
		10.0	13.0	F13	980	3100	28	0.12	188	80SXE47M
	56	10.0	13.0	F13	980	3100	28	0.12	224	80SXE56M
82	10.0	13.0	F13	980	3100	28	0.12	328	80SXE82M	
100	6.8	8.0	7.0	E7	340	1100	60	0.12	34	100SXE6R8M
	15	10.0	8.0	F8	630	2000	60	0.12	75	100SXE15MX
		8.0	12.0	E12	730	2350	40	0.12	75	100SXE15M
	18	10.0	13.0	F13	940	3000	30	0.12	90	100SXE18M
		8.0	12.0	E12	730	2350	40	0.12	90	100SXE18MX
	22	10.0	13.0	F13	940	3000	30	0.12	110	100SXE22M
	27	8.0	12.0	E12	730	2350	40	0.12	135	100SXE27MX
		10.0	13.0	F13	940	3000	30	0.12	135	100SXE27M
	39	10.0	13.0	F13	940	3000	30	0.12	195	100SXE39M

*1: Ripple current (100 kHz / +105 °C < Tx ≤ +125 °C) / Allowable ripple current (100 kHz / Tx ≤ +105 °C)

*2: ESR (100 kHz to 300 kHz / +20 °C)

*3: tan δ (120 Hz / +20 °C)

*4: After 2 minutes

◆ Please refer to each page in this catalog for "Flow conditions" and "Taping specifications".

Frequency correction factor for ripple current

Frequency(f)	120 Hz ≤ f < 1 kHz	1 kHz ≤ f < 10 kHz	10 kHz ≤ f < 100 kHz	100 kHz ≤ f < 500 kHz
Coefficient	0.05	0.3	0.7	1

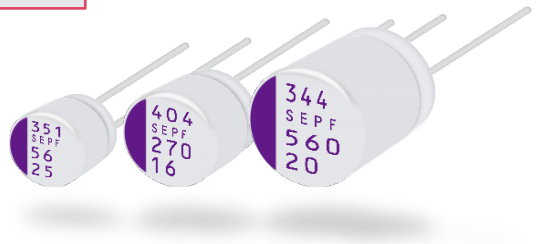

Conductive Polymer Aluminum
Solid Capacitors
Radial Lead Type
SEPF series

Features

- High voltage (35 V max.)
- Large capacitance (1000 μF max.)
- RoHS compliance, Halogen free

Specifications

Size code	C55	C6	E7	E12	F13
Category temp. range	-55 °C to +105 °C				
Rated voltage range	16 V to 32 V	16 V to 35 V			
Nominal cap.range	22 μF to 150 μF	22 μF to 180 μF	39 μF to 270 μF	82 μF to 560 μF	120 μF to 1000 μF
Capacitance tolerance	±20 % (120 Hz / +20 °C)				
DC leakage current	Please see the attached characteristics list				
Dissipation factor (tan δ)	Please see the attached characteristics list				
Endurance	+105 °C 5000 h, rated voltage applied				
	Capacitance change	Within ±20 % of the initial value			
	Dissipation factor (tanδ)	≤ 150 % of the initial limit			
	DC leakage current	Within the initial limit			
Damp heat (Steady state)	+60 °C, 90 % to 95 % RH, 1000 h, No-applied voltage				
	Capacitance change	Within ±20 % of the initial value			
	Dissipation factor (tanδ)	≤ 150 % of the initial limit			
	DC leakage current	Within the initial limit (after voltage processing)			

Marking

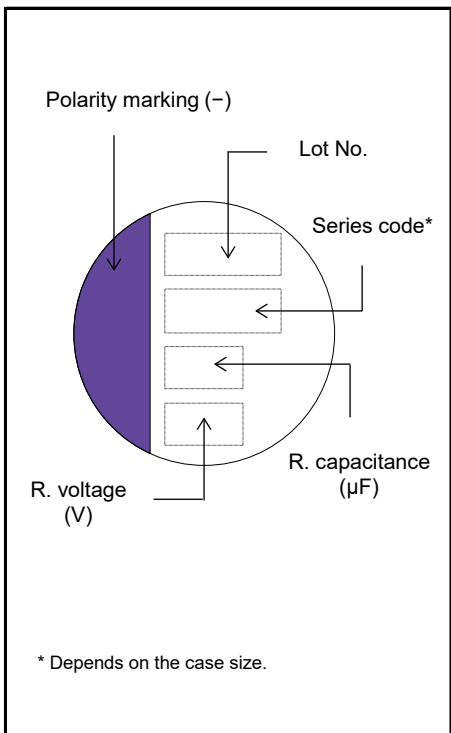

Dimensions (not to scale)

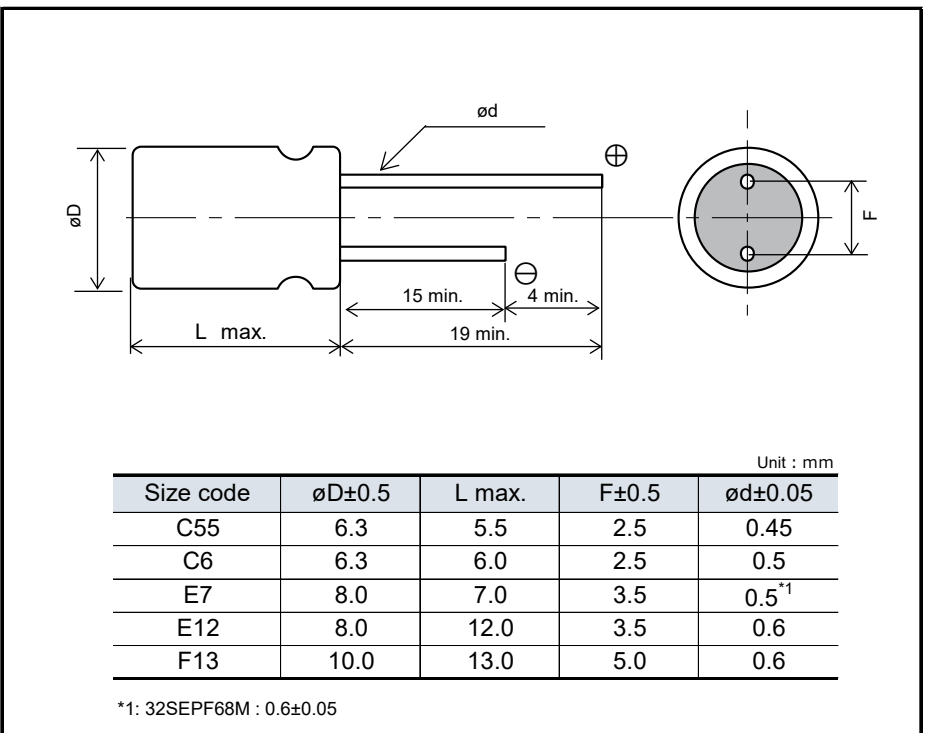

Characteristics list

Rated voltage (V)	Rated capacitance ($\pm 20\%$) (μF)	Case size (mm)		Size code	Specifications				Part number <small>Click here for part number list of lead terminal cutting and lead terminal taping</small>
		$\varnothing\text{D}$	L		Ripple current ^{*1} (mA rms)	ESR ^{*2} (m Ω max.)	$\tan \delta$ ^{*3}	LC ^{*4} (μA)	
16	150	6.3	5.5	C55	2590	30	0.12	480	16SEPF150M
	180	6.3	6.0	C6	3300	22	0.12	576	16SEPF180M
	270	8.0	7.0	E7	3300	22	0.12	864	16SEPF270M
	560	8.0	12.0	E12	4950	14	0.12	1792	16SEPF560M
	1000	10.0	13.0	F13	5400	12	0.12	3200	16SEPF1000M
20	120	6.3	6.0	C6	3200	25	0.12	480	20SEPF120M
	180	8.0	7.0	E7	3200	25	0.12	720	20SEPF180M
	390	8.0	12.0	E12	4950	14	0.12	1560	20SEPF390M
	560	10.0	13.0	F13	5400	12	0.12	2240	20SEPF560M
25	56	6.3	6.0	C6	2800	30	0.12	280	25SEPF56M
	82	8.0	7.0	E7	3000	28	0.12	410	25SEPF82M
	180	8.0	12.0	E12	4650	16	0.12	900	25SEPF180M
	330	10.0	13.0	F13	5000	14	0.12	1650	25SEPF330M
32	22	6.3	5.5	C55	2400	35	0.12	140	32SEPF22M
	68	8.0	7.0	E7	3200	25	0.10	435	32SEPF68M
35	22	6.3	6.0	C6	2600	35	0.12	154	35SEPF22M
	39	8.0	7.0	E7	2800	30	0.12	273	35SEPF39M
	82	8.0	12.0	E12	4000	20	0.12	574	35SEPF82M
	120	10.0	13.0	F13	4400	18	0.12	840	35SEPF120M

*1: Ripple current (100 kHz / +105 °C)

*2: ESR (100 kHz to 300 kHz / +20 °C)

*3: $\tan \delta$ (120 Hz / +20 °C)

*4: After 2 minutes

◆ Please refer to each page in this catalog for "Flow conditions" and "Taping specifications".

Frequency correction factor for ripple current

Frequency(f)	120 Hz \leq f < 1 kHz	1 kHz \leq f < 10 kHz	10 kHz \leq f < 100 kHz	100 kHz \leq f < 500 kHz
Coefficient	0.05	0.3	0.7	1

**Conductive Polymer Aluminum
Solid Capacitors**
Radial Lead Type
SEPC series



Features

- Super low ESR (5 mΩ max.)
- Large capacitance (2700 μF max.)
- RoHS compliance, Halogen free

Specifications

Size code	B9	C55	C6	C9	E7	E9	E12	E13	F13
Category temp. range	-55 °C to +105 °C								
Rated voltage range (V)	2.5	6.3	2.5 to 16		6.3 to 16	2.5 to 16	16	2.5 to 6.3	2.5 to 16
Nominal cap.range (μF)	100 to 560	220	100 to 560	100 to 820	150 to 1000	180 to 1000	180 to 270	470 to 820	470 to 2700
Capacitance tolerance	±20 % (120 Hz / +20 °C)								
DC leakage current	Please see the attached characteristics list								
Dissipation factor (tan δ)	Please see the attached characteristics list								
Endurance	+105 °C 5000 h, rated voltage applied								
	Capacitance change	Within ±20 % of the initial value							
	Dissipation factor (tanδ)	≤ 150 % of the initial limit							
	DC leakage current	Within the initial limit							
Damp heat (Steady state)	+60 °C, 90 % to 95 % RH, 1000 h, No-applied voltage								
	Capacitance change	Within ±20 % of the initial value							
	Dissipation factor (tanδ)	≤ 150 % of the initial limit							
	DC leakage current	Within the initial limit (after voltage processing)							

Marking

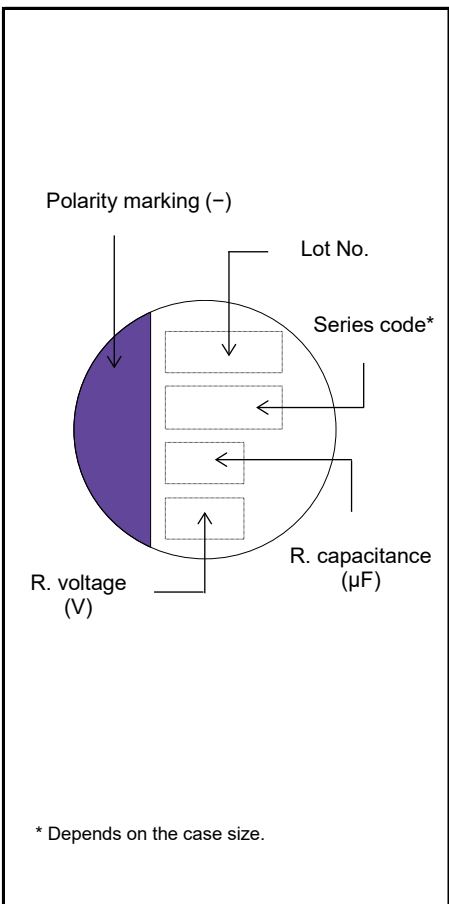

Dimensions (not to scale)

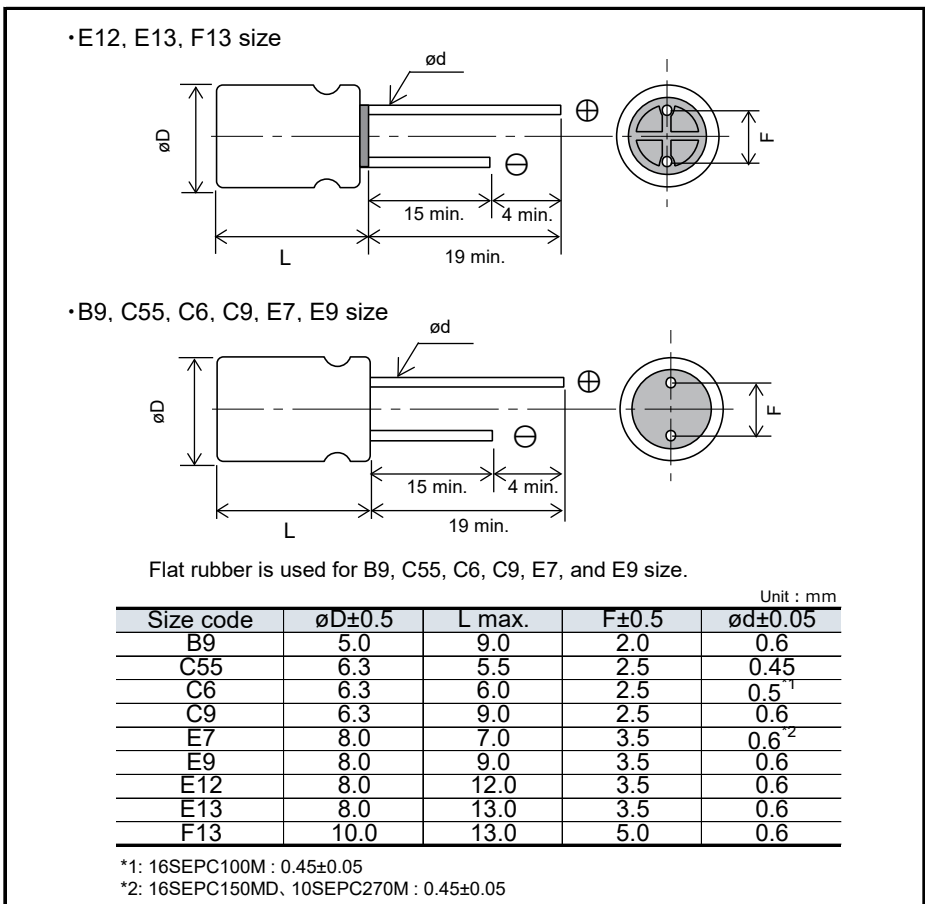

Characteristics list

Rated voltage (V)	Rated capacitance ($\pm 20\%$) (μF)	Case size (mm)		Size code	Specifications				Part number Click here for part number list of lead terminal cutting and lead terminal taping
		$\varnothing\text{D}$	L		Ripple current ^{*1} (mA rms)	ESR ^{*2} (m Ω max.)	$\tan \delta$ ^{*3}	LC ^{*4} (μA)	
2.5	100	5.0	9.0	B9	4180	7	0.10	500	2SEPC100MZ
	330	5.0	9.0		4180	7	0.10	500	2SEPC330MZ
	390	6.3	6.0	C6	3900	10	0.12	500	2SEPC390M
	470	5.0	9.0	B9	4180	7	0.10	500	2SEPC470MZ
	560	5.0	9.0		4180	7	0.10	500	2SEPC560MZ
		6.3	6.0	C6	3900	10	0.12	500	2SEPC560M
		6.3	9.0	C9	5600	7	0.10	500	2SEPC560MW
	820	8.0	9.0	E9	4700	8	0.10	280	2SEPC560MX
		6.3	9.0	C9	5600	7	0.10	500	2SEPC820MW
		8.0	7.0	E7	5300	8	0.10	500	2SEPC820MD
		8.0	9.0	E9	6100	7	0.10	500	2SEPC820MX
		8.0	9.0		7200	5	0.10	500	2SEPC820MY
	8.0	13.0	E13	6100	7	0.10	500	2R5SEPC820M	
	1000	8.0	9.0	E9	6100	7	0.10	500	2SEPC1000MX
2700	10.0	13.0	F13	5560	10	0.10	1350	2SEPC2700M	
4.0	560	6.3	9.0	C9	5600	7	0.10	500	4SEPC560MW
		8.0	9.0	E9	6100	7	0.10	500	4SEPC560MX
		8.0	13.0	E13	6100	7	0.10	500	4SEPC560M
	680	8.0	13.0		6100	7	0.10	544	4SEPC680M
	820	10.0	13.0	F13	6640	7	0.10	656	4SEPC820M
6.3	220	6.3	5.5	C55	2980	18	0.12	280	6SEPC220M
	470	6.3	9.0	C9	5600	7	0.10	592	6SEPC470MW
		8.0	9.0	E9	5700	8	0.10	592	6SEPC470MX
		8.0	13.0	E13	5700	8	0.10	592	6SEPC470M
	560	6.3	9.0	C9	5600	7	0.10	705	6SEPC560MW
		8.0	9.0	E9	6100	7	0.10	705	6SEPC560MX
	680	10.0	13.0	F13	6640	7	0.10	857	6SEPC680M
	1000	8.0	7.0	E7	3530	18	0.10	1260	6SEPC1000MD
1500	10.0	13.0	F13	5560	10	0.10	1890	6SEPC1500M	
10	270	8.0	7.0	E7	3220	22	0.12	500	10SEPC270MD
16	100	6.3	6.0	C6	2490	24	0.10	320	16SEPC100M
		6.3	9.0	C9	4680	10	0.10	500	16SEPC100MW
	150	8.0	7.0	E7	3220	22	0.12	500	16SEPC150MD
	180	8.0	9.0	E9	5000	10	0.10	576	16SEPC180MX
		8.0	12.0	E12	4360	16	0.10	576	16SEPC180M
	220	8.0	7.0	E7	4150	13	0.10	500	16SEPC220MD
	270	8.0	9.0	E9	5000	10	0.10	864	16SEPC270MX
		8.0	12.0	E12	5000	11	0.10	864	16SEPC270M
	470	10.0	13.0	F13	6100	10	0.10	1504	16SEPC470M

*1: Ripple current (100 kHz / +105 °C)

*2: ESR (100 kHz to 300 kHz / +20 °C)

*3: $\tan \delta$ (120 Hz / +20 °C)

*4: After 2 minutes

◆ Please refer to each page in this catalog for "Flow conditions" and "Taping specifications".

Frequency correction factor for ripple current

Frequency(f)	120 Hz \leq f < 1 kHz	1 kHz \leq f < 10 kHz	10 kHz \leq f < 100 kHz	100 kHz \leq f < 500 kHz
Coefficient	0.05	0.3	0.7	1

Conductive Polymer Aluminum Solid Capacitors

Radial Lead Type

SEQP series



Features

- High voltage (32 V max.)
- 125 °C 1000 h
- RoHS compliance, Halogen free

Specifications

Size code	C6	E7	E12	F8	F13
Category temp. range	-55 °C to +125 °C				
Rated voltage range	4.0 V to 20 V	4.0 V to 32 V			4.0 V to 20 V
Nominal cap.range	22 µF to 150 µF	6.8 µF to 330 µF	18 µF to 560 µF	15 µF to 680 µF	150 µF to 1200 µF
Capacitance tolerance	±20 % (120 Hz / +20 °C)				
DC leakage current	Please see the attached characteristics list				
Dissipation factor (tan δ)	Please see the attached characteristics list				
Endurance	+125 °C 1000 h / +105 °C 5000 h, rated voltage applied				
	Capacitance change	Within ±20 % of the initial value			
	Dissipation factor (tanδ)	≤ 200 % of the initial limit			
	DC leakage current	Within the initial limit			
Damp heat (Steady state)	+60 °C, 90 % to 95 % RH, 1000 h, No-applied voltage				
	Capacitance change	Within ±20 % of the initial value			
	Dissipation factor (tanδ)	≤ 150 % of the initial limit			
	DC leakage current	Within the initial limit (after voltage processing)			

Marking

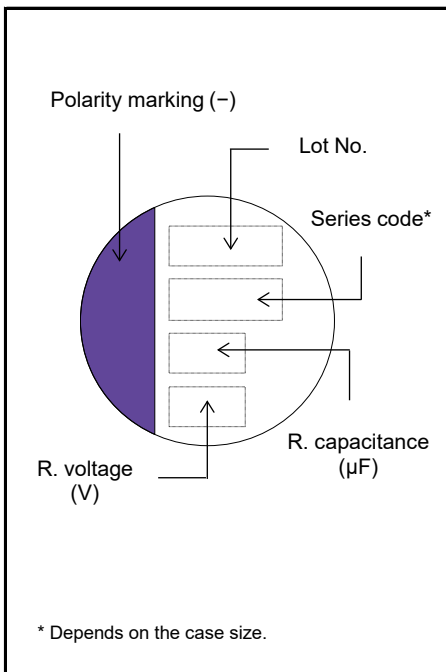

Dimensions (not to scale)

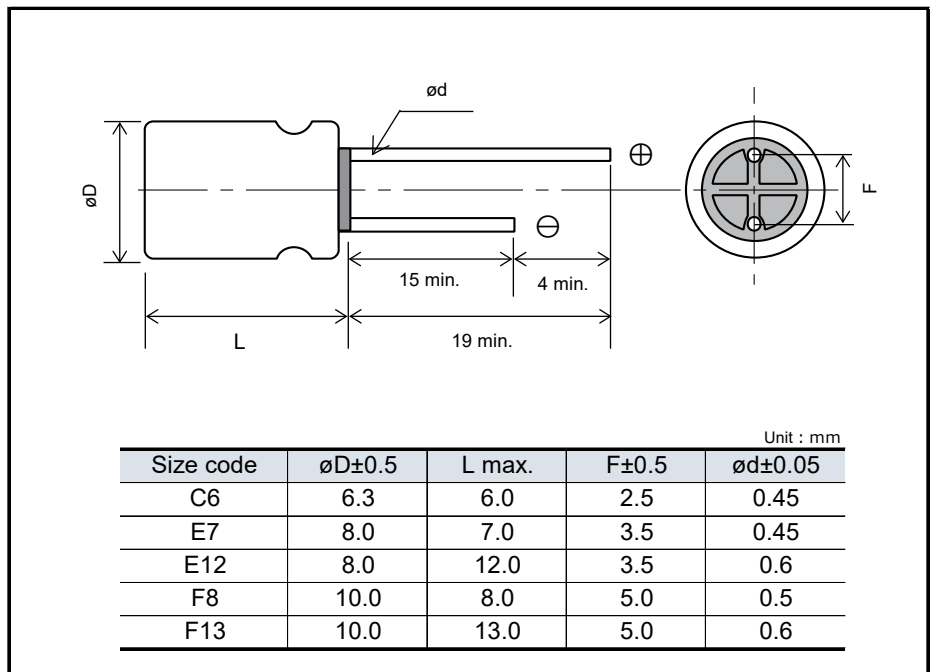

Characteristics list

Rated voltage (V)	Rated capacitance ($\pm 20\%$) (μF)	Case size (mm)		Size code	Specifications					Part number <small>Click here for part number list of lead terminal cutting and lead terminal taping</small>
		$\varnothing\text{D}$	L		Ripple current ^{*1} (mA rms)	Allowable ripple current ^{*1} (mA rms)	ESR ^{*2} (m Ω max.)	$\tan \delta$ ^{*3}	LC ^{*4} (μA)	
4.0	150	6.3	6.0	C6	572	1810	40	0.12	300	4SEQP150M
	330	8.0	7.0	E7	810	2560	35	0.12	660	4SEQP330M
	560	8.0	12.0	E12	1430	4520	13	0.15	448	4SEQP560M
	680	10.0	8.0	F8	1170	3700	25	0.12	544	4SEQP680M
	1200	10.0	13.0	F13	1721	5440	12	0.18	960	4SEQP1200M
6.3	82	6.3	6.0	C6	537	1700	45	0.12	258	6SEQP82M
	150	8.0	7.0	E7	810	2560	35	0.12	472	6SEQP150M
	330	10.0	8.0	F8	1170	3700	25	0.12	416	6SEQP330M
	470	8.0	12.0	E12	1332	4210	15	0.15	592	6SEQP470M
	820	10.0	13.0	F13	1721	5440	12	0.15	775	6SEQP820M
10	56	6.3	6.0	C6	537	1700	45	0.12	280	10SEQP56M
	120	8.0	7.0	E7	810	2560	35	0.12	600	10SEQP120M
	270	10.0	8.0	F8	1170	3700	25	0.12	540	10SEQP270M
	330	8.0	12.0	E12	1250	3950	17	0.15	660	10SEQP330M
	560	10.0	13.0	F13	1655	5230	13	0.15	840	10SEQP560M
16	39	6.3	6.0	C6	512	1620	50	0.10	312	16SEQP39M
	82	8.0	7.0	E7	670	2120	40	0.12	656	16SEQP82M
	150	10.0	8.0	F8	955	3020	30	0.12	480	16SEQP150M
	180	8.0	12.0	E12	1151	3640	20	0.15	576	16SEQP180M
	330	10.0	13.0	F13	1493	4720	16	0.15	792	16SEQP330M
20	22	6.3	6.0	C6	458	1450	60	0.10	220	20SEQP22M
	47	8.0	7.0	E7	598	1890	45	0.12	470	20SEQP47M
	68	10.0	8.0	F8	759	2400	40	0.12	272	20SEQP68M
	100	8.0	12.0	E12	1050	3320	24	0.15	400	20SEQP100M
	150	10.0	13.0	F13	1367	4320	20	0.15	600	20SEQP150M
32	6.8	8.0	7.0	E7	440	1400	100	0.10	44	32SEQP6R8M
	15	10.0	8.0	F8	560	1800	80	0.10	96	32SEQP15M
	18	8.0	12.0	E12	790	2500	50	0.12	115	32SEQP18M

*1: Ripple current (100 kHz / +105 °C < Tx \leq +125 °C) / Allowable ripple current (100 kHz / Tx \leq +105 °C)

*2: ESR (100 kHz to 300 kHz / +20 °C)

*3: $\tan \delta$ (120 Hz / +20 °C)

*4: After 2 minutes

◆ Please refer to each page in this catalog for "Flow conditions" and "Taping specifications".

Frequency correction factor for ripple current

Frequency(f)	120 Hz \leq f < 1 kHz	1 kHz \leq f < 10 kHz	10 kHz \leq f < 100 kHz	100 kHz \leq f < 500 kHz
Coefficient	0.05	0.3	0.7	1

Conductive Polymer Aluminum
Solid Capacitors
Radial Lead Type
SEP series



Features

- Standard
- 105 °C 3000 h
- RoHS compliance, Halogen free

Specifications

Size code	C6	E7	E12	F8	F13
Category temp. range	-55 °C to +105 °C				
Rated voltage range	4.0 V to 20 V		2.5 V to 20 V	4.0 V to 20 V	2.5 V to 20 V
Nominal cap.range	22 µF to 150 µF	33 µF to 330 µF	100 µF to 680 µF	56 µF to 680 µF	150 µF to 1500 µF
Capacitance tolerance	±20 % (120 Hz / +20 °C)				
DC leakage current	Please see the attached characteristics list				
Dissipation factor (tan δ)	Please see the attached characteristics list				
Endurance	+105 °C 3000 h, rated voltage applied (2.5 V products : 2000 h)				
	Capacitance change	Within ±20 % of the initial value			
	Dissipation factor (tanδ)	≤ 150 % of the initial limit			
	DC leakage current	Within the initial limit			
Damp heat (Steady state)	+60 °C, 90 % to 95 % RH, 1000 h, No-applied voltage				
	Capacitance change	Within ±20 % of the initial value			
	Dissipation factor (tanδ)	≤ 150 % of the initial limit			
	DC leakage current	Within the initial limit (after voltage processing)			

Marking

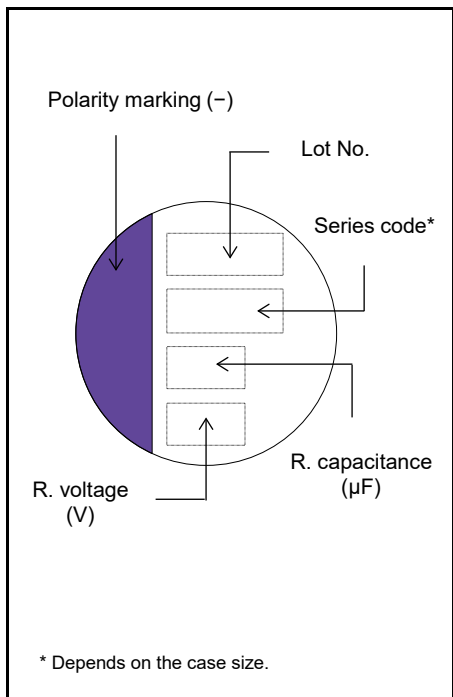

Dimensions (not to scale)

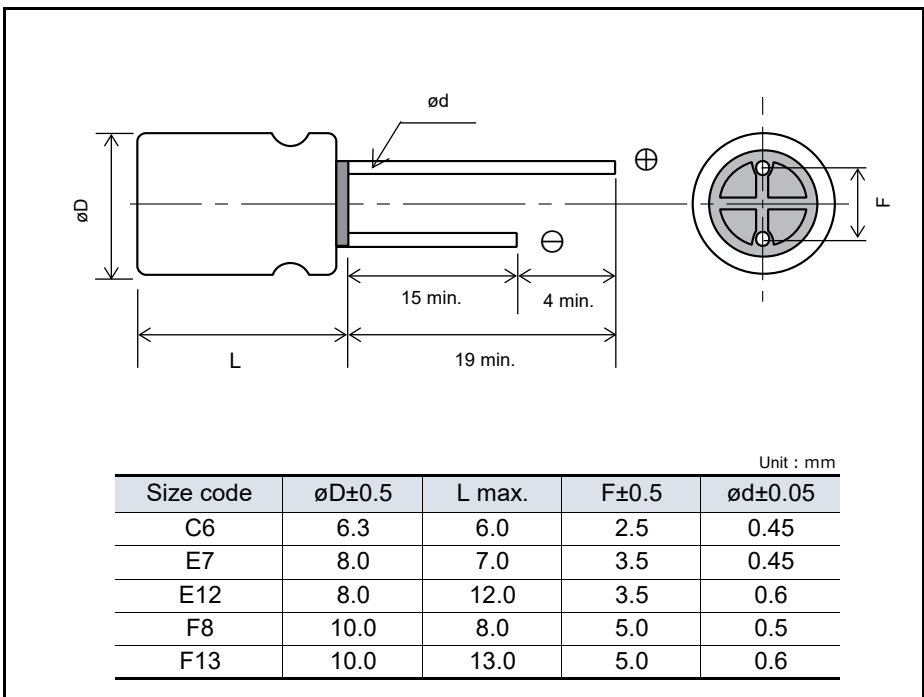

Characteristics list

Rated voltage (V)	Rated capacitance ($\pm 20\%$) (μF)	Case size (mm)		Size code	Specifications				Part number Click here for part number list of lead terminal cutting and lead terminal taping
		$\varnothing\text{D}$	L		Ripple current ^{*1} (mA rms)	ESR ^{*2} (m Ω max.)	$\tan \delta$ ^{*3}	LC ^{*4} (μA)	
2.5	680	8.0	12.0	E12	4520	13	0.15	340	2R5SEP680M
	1500	10.0	13.0	F13	5440	12	0.18	750	2R5SEP1500M
4.0	100	6.3	6.0	C6	1810	40	0.12	200	4SEP100M
	150	6.3	6.0		1810	40	0.12	300	4SEP150M
	220	8.0	7.0	E7	2560	35	0.12	440	4SEP220M
	330	8.0	7.0		2560	35	0.12	660	4SEP330M
	470	10.0	8.0	F8	3700	25	0.12	376	4SEP470M
	560	8.0	12.0	E12	4520	13	0.15	448	4SEP560M
	680	10.0	8.0	F8	3700	25	0.12	544	4SEP680M
	1200	10.0	13.0	F13	5440	12	0.18	960	4SEP1200M
6.3	82	6.3	6.0	C6	1700	45	0.12	258	6SEP82M
	150	8.0	7.0	E7	2560	35	0.12	472	6SEP150M
	330	10.0	8.0	F8	3700	25	0.12	416	6SEP330M
	470	8.0	12.0	E12	4210	15	0.15	592	6SEP470M
	820	10.0	13.0	F13	5440	12	0.15	775	6SEP820M
10	56	6.3	6.0	C6	1700	45	0.12	280	10SEP56M
	120	8.0	7.0	E7	2560	35	0.12	600	10SEP120M
	270	10.0	8.0	F8	3700	25	0.12	540	10SEP270M
	330	8.0	12.0	E12	3950	17	0.15	660	10SEP330M
	560	10.0	13.0	F13	5230	13	0.15	840	10SEP560M
16	39	6.3	6.0	C6	1620	50	0.10	312	16SEP39M
	82	8.0	7.0	E7	2120	40	0.12	656	16SEP82M
	150	10.0	8.0	F8	3020	30	0.12	480	16SEP150M
	180	8.0	12.0	E12	3640	20	0.15	576	16SEP180M
	330	10.0	13.0	F13	4720	16	0.15	792	16SEP330M
20	22	6.3	6.0	C6	1450	60	0.10	220	20SEP22M
	33	8.0	7.0	E7	1890	45	0.12	330	20SEP33M
	47	8.0	7.0		1890	45	0.12	470	20SEP47M
	56	10.0	8.0	F8	2400	40	0.12	224	20SEP56M
	68	10.0	8.0		2400	40	0.12	272	20SEP68M
	100	10.0	8.0		2570	35	0.12	400	20SEP100MX
		8.0	12.0	E12	3320	24	0.15	400	20SEP100M
	150	10.0	13.0	F13	4320	20	0.15	600	20SEP150M

*1: Ripple current (100 kHz / +105 °C)

*2: ESR (100 kHz to 300 kHz / +20 °C)

*3: $\tan \delta$ (120 Hz / +20 °C)

*4: After 2 minutes

◆ Please refer to each page in this catalog for "Flow conditions" and "Taping specifications".

Frequency correction factor for ripple current

Frequency(f)	120 Hz $\leq f < 1$ kHz	1 kHz $\leq f < 10$ kHz	10 kHz $\leq f < 100$ kHz	100 kHz $\leq f < 500$ kHz
Coefficient	0.05	0.3	0.7	1

Conductive Polymer Hybrid Aluminum Electrolytic Capacitors

Hybrid

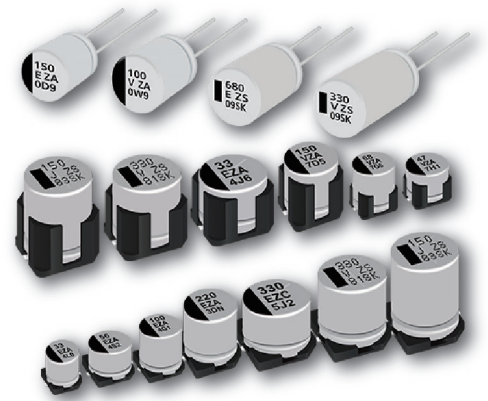

INDEX

Application Guidelines (Hybrid)	P153
Line-up / Diagram	P159
Voltage - Capacitance table	P161
Explanation of part numbers	P163
Mounting / Packing specifications	P165
Each series	P167

Applications

Main market

Communications infrastructure



Automotive

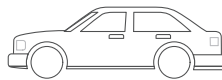

Industrial equipment

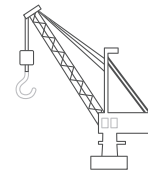

Desktop computer



Audio / Visual

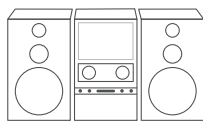

Server

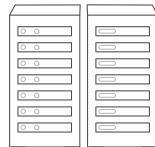

Home appliance

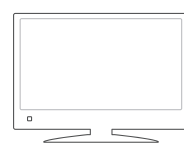

Industrial robot

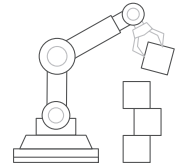

Matters to Be Observed When Using This Product

(Conductive polymer hybrid aluminum electrolytic capacitor / Aluminum electrolytic capacitor)

Use environments and cleaning conditions

- This product (capacitor) is intended for standard general-purpose use in electronic equipment, and is not designed for use in the specific environments described below. Using the product in such specific environments or service conditions, therefore, may affect the performance of the product.
Check with us about the performance and reliability of the product first before using the product.

- (1) Used at a temperature higher than the upper limit category temperature or lower than the lower limit category temperature.
- (2) Used in an environment where the product is directly exposed to water, salt water, oil, etc., or in a liquid, such as water, oil, chemicals, and organic solvents.
- (3) Used in an outdoor environment where the product is exposed to direct sunlight, ozone, radiation, UV-rays, etc., or in a dusty place.
- (4) Used in a wet place (dew concentration on a resistor, water leakage, etc.), a place exposed to sea breeze, or a place filled with a corrosive gas, such as Cl₂, H₂S, NH₃, SO₂, or NO_x.
- (5) Used in an environment filled with a toxic gas (hydrogen sulfide, sulfurous acid, nitrous acid, chlorine and chlorine compound, bromine and bromine compound, ammonia, etc.)
- (6) Used in an environment where static electricity and electromagnetic waves are strong.
- (7) Located close to heating component or a flammable material, such as a vinyl cable.
- (8) Sealed with a resin, etc.
- (9) Cleansed with a solvent, water, or a water-soluble cleaner, to remove solder flux after soldering.
- (10) Used in an environment where an acidic or alkali atmosphere is present.
- (11) Used in an environment where excessive vibration or mechanical shocks exceeding a specified range is applied to the product (even if the applied vibration or mechanical shocks is within the specified range, it may cause the product to resonate, in which a large vibration acceleration may be generated. Make sure to evaluate/check such vibrations or mechanical shocks applied to the product in an actual condition).

Panasonic Industry's conditions for vibration test are shown in the table below. Random waveform is not guaranteed. For radial type, datasheet is also available if requested.

Item	Standard	Vibration-proof
Waveform	Sine	Sine
Frequency	10 - 55 Hz	5 - 2000 Hz
Direction	X, Y, Z axis	X, Y, Z axis
Duration	2 hours each direction	2 hours each direction
Max p-p amplitude	1.5mm _{pp}	5mm _{pp}
Max acceleration	90 m/s ² (9.1 G)	294 m/s ² (30 G)

- (12) Used under a low atmospheric pressure condition or depressurized condition.
- The capacitor withstands an immersion cleaning process where the board carrying the product is immersed in a cleaning solution of 60 °C or lower for less than 5 minutes and withstands an ultrasonic cleaning process as well. However, ensure to thoroughly rinse and dry it. Some cleaning methods erase or blur notes on the capacitor in some cases. Some types of capacitors are not washable and some cleaning solutions cannot be used to clean a capacitor. The following water-base solvents have been validated for cleaning. Contact a sales representative for more information.
Pine Alpha ST-100S, Cleanthrough 750H/750L/710M
 - Keep the cleaning solution under strict contamination control (conductivity, pH, specific gravity, water content, etc.). A contaminated cleaning solution will show a high chlorine concentration, thereby corroding the interior of the capacitor in some cases. Keep the flux concentration in the cleaning solution at a 2% mass or less.
 - Unless otherwise specified in the specifications, avoid cleaning the capacitor with a halogen-based solvent, an alkaline solvent, a petroleum-based solvent, xylene, or acetone. Using a halogen-based solvent may result in a case where the solvent infiltrates (leaks) into the capacitor and break-down releasing chlorine, which reacts with aluminum which can corrode the capacitor interior. 1-1-1 trichloroethane is particularly harmful to a capacitor. Never use it to clean a capacitor. A alkaline solvent may corrode (dissolve) an aluminum case, a petroleum-based solvent and xylene may damage the sealing rubber and accelerate its deterioration, and acetone may erase notes on the capacitor.
To protect the global environment, refrain from using an ozone depleting substance as the cleaning solution.
 - Right after the board cleaning, subject the capacitor to a forced drying process so that no cleaning solution remains between the sealing part of the capacitor and the printed board.
Set a drying temperature equal to or lower than the upper limit category temperature.

- When an adhesive or coating agent is used to fix the capacitor and prevent dampening of the board, specific types of solvents included in some adhesives or coating agents may corrode the capacitor. Select a non-halogen solvent for the material making up the adhesive or coating agent. Do not use a chloroprene-based polymer. Solidify and dry the adhesive or coating agent sufficiently to prevent its solvent component from remaining on the capacitor. Leave at least 1/3 of the sealing part unsealed on the surface to which the adhesive or coating agent is applied.
- Do not use the product in a structure sealed by potting or molding. The pressure of a molding resin on a capacitor may deform the capacitor. In addition, the resin covering the capacitor may affect its heat dissipation performance or may leak into the product. These factors lead to the significant degradation of the capacitor's characteristics and reliability. There is also a concern that an electrolytic solution permeating the sealing rubber may agglomerate and cause a short circuit.
- When the capacitor is used in a circuit where an impact voltage is applied or a high voltage is applied in a short period (transient phenomenon) or a high pulse voltage is applied, make sure to use the capacitor at a voltage equal to or lower than its rated voltage.
- The product contains an electrolytic. Improper use of the capacitor leads not only to the rapid degradation of its characteristics but also to electrolytic leakage. These problems damage the circuit board and may lead to destruction of the entire circuit set.

Response to anomalies and handling conditions

- When you see gas coming out of an activated pressure relief valve of a capacitor during use of a circuit set, turn off the main power supply of the circuit set or pull the power cord plug out of the wall-outlet. If you leave the power supply on and the capacitor short-circuits, it will damage the circuit, or the gas can turn into a liquid, which will cause the circuit to short. In the worst case scenarios, these events may develop into a more serious incident, such as burnout of the circuit set. The gas coming out of the pressure relief valve of a capacitor is not smoke, but is the electrolytic solution in its gaseous state.
- When the pressure valve of the capacitor is activated, it emits a high-temperature gas of over 100 °C. Do not bring your face near the valve. In case the gas jetting out of the valve gets in your eyes or comes into your mouth, wash your eyes with water or rinse your mouth immediately. If the gas hits your skin, wash it away with soap.
- If you touch a terminal of the product during use of the circuit set, you will get an electric shock. The aluminum case of the product has an exposed part with no insulation. Do not touch the exposed part because it is as dangerous as the terminal.
- Do not create a short circuit between terminals of the product by inserting a conductor therebetween. Do not splash a conductive solution, such as an acidic or alkali solution, on the capacitor. It puts the capacitor in a shorted state, which causes the circuit to fail and destroys the capacitor as well.
- When a silicone material containing a relatively large amount of a low-molecular-weight siloxane is located close to the product, it may cause the capacitor problems with its electrical performance.
- When electronic equipment having the capacitor built therein is exported to overseas markets, wooden packaging materials are fumigated with a halogen compound, such as methyl bromide. In such cases, if the packaging material subjected to the fumigation treatment is not dried sufficiently, halogen remaining on the packaging material may leach into the capacitor during transportation and trigger a corrosive reaction in the capacitor. When carrying out the fumigation treatment, carefully examine the dried packaging material to confirm that no halogen remains on the packaging material. Never fumigate the entire electronic equipment in its packaged state.

Reliability and product life

- The product life is affected by temperatures. In general, a 10 °C drop in the temperature will double the life. Use the capacitor at a temperature as low as possible from the upper limit category temperature.
- Using a capacitor under a temperature condition outside a specified temperature range causes heavy degradation of the capacitor characteristics, which may result in breakage of the capacitor. You need to confirm not only the ambient temperature and internal temperature of the capacitor but also the temperature of the capacitor's top surface, which is given by radiant heat from built-in heating elements (a power transistor, IC, resistance, etc.) and heat generated by self-heating induced by ripple current. Do not place a heating element on the back of the capacitor.

- The product life is given by the following equation.

$$L2 = L1 \times 2^{\frac{T1-(T2+\Delta T)}{10}} \quad \text{Where } T1 \geq T2$$

- L1 : Guaranteed life (h) at temperature T1 (°C)
- L2 : Expected life (h) at temperature T2 (°C) * In the case of a hybrid type, category temperature (°C)
- T1 : Upper category temperature (°C) + temperature increase caused by rated ripple current (°C)
- T2 : Ambient temperature of capacitor (°C)
- ΔT : Temperature increase caused by ripple current (°C)

- Do not use the product for a period longer than its specified service life. A capacitor with its service life ended may cause the following problems: rapid degradation of the product characteristics, short circuit, unnecessary activation of the pressure valve, electrolytic solution leakage, etc. Note that the estimated service life is not longer than 15 years due to the limited environment-resistant property of the sealing rubber.
- When the capacitor is used under a high-temperature condition for a long period, minute cracks develop on the surface of the sealing rubber or the case surface turns brown in some cases. These phenomena, however, have no effects on the reliability of the capacitor.
- A capacitor conforming to "AEC-Q200" refers to a capacitor having passed some or all of evaluation test items defined in AEC-Q200.
To know the detailed specifications of each capacitor or specific evaluation test scores, please contact us.
We issue a the product specifications sheet for each product ordered. Please confirm the product specifications sheet when you place an order to us.

Circuit design and circuit board design

- The electrical characteristics change as a result of temperature/frequency fluctuations. Take electrical characteristic changes into consideration when working out a circuit design.
 - (1) Temperature fluctuations
 - High-temperature condition : increase in leak current
 - Low-temperature condition : decrease in capacitance, increase in the tangent to the loss angle, increase in impedance (the hybrid type is excluded), etc.
 - (2) Frequency fluctuations
 - High-frequency condition : decrease in capacitance, increase in the tangent to the loss angle, decrease in impedance, etc.
 - Low-frequency condition : more heat generation by ripple current as a result of an increase in equivalent series resistance
- The group of factors described below may lead to rapid degradation of the capacitor characteristics, short circuit, or electrolytic solution leakage. They may give rise to sharp heat/gas generation, too, in which case the increasing internal pressure actuates the pressure valve, causes the electrolytic solution to leak out of the sealing part, and, in a worst-case scenario, causes an explosion or ignition incident. When a capacitor bursts, it may scatter flammable materials (electrolytic solution, etc.) in its surroundings.
 - (1) Reverse voltage: The capacitor has preset polarity. Do not apply a reverse voltage to the capacitor.
Confirm the polarity indicated on the capacitor and then use it.
 - (2) Charge/discharge: Avoid using the capacitor in a circuit that frequently repeats sharp charge/discharge cycles or a circuit that requires relatively slow but highly frequent charge/discharge cycles. In cases where you use the capacitor in such circuits, make sure to inform us of the charge/discharge conditions.
Ensure that a rush current does not exceed 100 A.
 - (3) ON/OFF: Avoid using the capacitor in an on/off circuit that repeatedly switches on and off more than 10,000 times a day. In cases where you use the product in such circuits, make sure to inform us of the circuit conditions, etc.
 - (4) Overvoltage: Do not apply an overvoltage higher than the rated voltage (higher than the surge voltage when the voltage application period is short). A peak value given by superposing a ripple voltage (AC component) on a DC voltage must be equal to or lower than the rated voltage.
 - (5) Ripple current: Do not allow an excessively large ripple current (larger than the rated ripple current specified in the specifications) to flow through the capacitor. Even if a ripple current flow in the capacitor is equal to or smaller than the rated ripple current, a reverse voltage flow may be generated in the capacitor when the DC bias voltage is low flow in the capacitor. Keep the ripple current flow within a range in which no reverse voltage is generated.
Even if the ripple current flow is kept equal to or smaller than the rated ripple current, using the capacitor for a period longer than its service life intensifies the degradation of the ESR characteristics, resulting in an increase in internal heating caused by the ripple current. As a result, the pressure valve is actuated, the exterior case or rubber swells, the electrolytic solution leaks, and, in a worst-case scenario, the capacitor short-circuits and ignites or explodes.

- Because the impedance of the capacitor is close to the circuit impedance, capacitors connected in parallel in the circuit may damage the whole current balance, in which, a ripple current higher than the rated ripple current may flow in some of the capacitors. To prevent concentration of ripple current on the low-impedance side, use capacitors with the same part number and avoid the partiality of cable impedances. Do not use capacitors connected in series.
- When the capacitor is mounted on a double-side wiring board, do not place the wiring pattern directly underneath where the product is mounted. In case the electrolytic solution leaks out, it may short-circuit the pattern and cause tracking or migration. Consider a case where the product is a radial lead capacitor and is mounted on a board with through-holes. In this case, if the sealing part of the capacitor and the board surface stick close to each other, solder flows up to the capacitor during a dip soldering process, which may cause short circuit between the anode and cathode of the capacitor. In such a case, the outer laminate of the product may be damaged. The position of holes, therefore, must be determined properly.
- When designing a printed board carrying radial lead capacitors, make through-holes across the gap equal to the gap between the leads (terminals) of the capacitor. If the gap between the through-holes is narrower or wider than the gap between the leads, stress is applied to the leads when the capacitor is inserted in the holes. This may result in increasing leak current, short circuit, wire breaking, or electrolytic solution leakage.
- A capacitor which has the pressure valve on the case must be provided with a space formed above the pressure valve so that the pressure valve operates without hinderance. When the product is 6.3 mm to 16 mm in diameter, form a space of 2 mm or larger. When the product is 18 mm in diameter, form a space of 3 mm or larger. If the space is not large enough, it will impair the operability of the pressure valve and may lead to an explosion incident.
- Design the circuit in such that the pattern, especially a line pattern carrying high voltage or large current, is not formed above the pressure valve. Upon its activation, the pressure valve emits a flammable high-temperature gas of over 100 °C. This may cause a secondary accident, such as the gas condensing on the pattern and the wire sheathing being melted and catching on fire.
- Be careful with resonance of the capacitor mounted on the board. When a large load is applied to the capacitor at the frequency close to the resonance frequency, it may cause the capacitor to come off or widely change its characteristics.
- Completely isolate the case of the capacitor from the cathode terminal and the circuit pattern.
- The laminate or outer sleeve covering of the product is for displaying information on the product and does not have a guaranteed insulating function. The laminate may turn brown under a high-temperature condition. However, that does not cause problems with markings recognition on the product surface or electrical performance. The outer sleeve may crack when dipped in a xylene or toluene solution and exposed to high temperature.

Mounting conditions

- Do not reuse a capacitor that was incorporated in a circuit set and energized in the past. Do not use a capacitor that was dropped on the floor. Do not use a capacitor in its compressed form. Compressing the capacitor makes it less airtight, resulting in poor performance, shorter guaranteed life, and electrolyte leakage.
- A re-striking voltage is generated in a capacitor in some cases. In such a case, let the capacitor discharge through a resistor of about 1 k Ω .
- When a capacitor is kept in storage for a long period, you may find the leak current from the capacitor has increased. In such a case, make voltage adjustment through a resistor of about 1 k Ω .
- Before mounting the capacitor on the board, confirm the ratings (capacitance, rated voltage, etc.) and polarity of the capacitor. Before mounting a surface-mounted type capacitor, confirm its terminal dimensions and land size. Before mounting a radial lead type capacitor, confirm its terminal interval and hole interval. If the terminal interval is not the specified one, stress is applied to internal elements, which may cause problems, such as a short circuit and insufficient mounting strength. When the terminal interval and the hole interval of the radial lead type capacitor do not match and therefore the capacitor's leads need to be readjusted, make sure that the readjustment does not apply any stress to the capacitor's body.

- Confirm the applied pressure when using an automatically mounting process for a surface-mounted type capacitor. Excessive pressure may result in increasing leak current, short circuit, the capacitor coming off from the board, and the like. When automatically mounting the radial lead type capacitor, check the wear of a cutter for cutting the leads and confirm that the angle of clinching the leads is not too acute with regards to the board. Clinching the leads at too acute of an angle applies tensile stress to the leads, which may lead to destruction of the capacitor.
- Follow soldering conditions (preheating, soldering temperature/time, the number of soldering, etc.) in the specification sheet. A high peak temperature or a long heating time causes the degradation of electrical characteristics or a reduction in the guaranteed life. Note that the specified soldering conditions indicate conditions under which the degradation of capacitor characteristics do not occur but do not indicate conditions under which stable soldering can be performed. Check and set conditions under which stable soldering can be performed, on a case-by-case basis. Measure the temperature of the capacitor, using a thermocouple bonded to the top of the capacitor with an epoxy-based adhesive. This temperature measurement must be conducted in a mass-production setup.
- The surface-mounted type capacitor is soldered by reflow soldering only. It cannot be soldered by flow soldering or dip soldering. Carry out reflow soldering with an atmospheric heat transfer method using infrared hot air, etc. When carrying out two rounds of reflow processes, carry out the second reflow process after the capacitor's temperature settles down to a normal temperature. In the case of VPS reflow, a sharp rise in the capacitor temperature causes a change in the characteristics and appearance of the capacitor, which may give rise to a problem with capacitor mounting. We therefore recommend execution of VPS flow at a temperature rise rate of 3 °C/second or lower. For more information about this matter, please contact us.
- Reflow soldering, under the reflow conditions we recommend, might result in discoloring or swelling of the case or crack formation on the ink mark indicating the cathode. These minor problems, however, do not affect the reliability of the capacitor at all.
- A 6.3-mm diameter vibration-resistant capacitor has a structure that covers the auxiliary terminals to the sides of a seat plate. In cases where you confirm formation of a fillet on the sides of the auxiliary terminals by an image recognition means, etc., examine soldering conditions for the formation of a sufficient fillet on the auxiliary terminals in advance before carrying out the soldering process. Even if the formation of a sufficient fillet on the auxiliary terminals is not confirmed, a solder junction between the lower surface of the auxiliary terminals and the board ensures vibration-resistant performance, meaning the reliability of the capacitor is not affected.
- The radial lead type capacitor cannot be soldered by reflow soldering. Do not dip the capacitor body, except the leads, in solder. Heat from the solder raises the internal pressure of the capacitor and destroys it. Solder the capacitor according to the following soldering conditions: soldering temperature of 260 °C ±5 °C and soldering time of 10 seconds ±1 second.
- Ensure that other components do not come in contact with the capacitor during the soldering process. When a radial lead type capacitor is set in close contact with the board, check the soldered state of the capacitor well, because its sealing rubber has no venting structure.
- When manually soldering the capacitor, follow the soldering conditions (soldering temperature/time) specified in the specification sheet or adopt a soldering temperature of 350 °C and a soldering time of 3 seconds or less. When you need to remove a capacitor already soldered, remove it after the solder is melted sufficiently so that no stress is applied to the terminals of the capacitor. Be careful not to let the solder iron tip touch the capacitor. The solder iron touching the capacitor may damage the capacitor.
- When the temperature of the capacitor becomes extremely high due to preheating, solidification of the setting resin, etc., may cause the outer sleeve of the capacitor to shrink or crack. When treating the capacitor in a thermosetting furnace, etc., place the capacitor in an atmosphere of 150 °C for 2 minutes or less.
- Do not tilt or twist the capacitor soldered to a printed board or hold the capacitor to carry the board or hit the capacitor against something. Such actions apply a force to the internal elements through the terminals and may destroy the product.
- Using highly active halogenous (chlorine-based or bromic) solder flux poses a concern that residual solder flux will have negative impact on the performance and reliability of the capacitor. Check the influence of residual solder flux before using such solder flux.

Storage conditions

- A capacitor left for a long period is prone to have a greater flow of leak current. This happens because the oxide film deteriorates under a no-load condition. Voltage application to the capacitor reduces the leak current. However, at the start of voltage application, a large flow of film recovery current increases the leak current, which may cause a circuit failure, etc.
- The storage period of a capacitor is 42 months from the shipment inspection day. However, the storage period of capacitors not listed in the following table is specified as 12 months. Store the capacitor in a place where a normal temperature condition (5°C to 35°C) and a normal humidity condition (45% to 85%) are maintained and direct sunlight is blocked.

Product category	Series	Storage period
Hybrid type	All hybrid series	42 months from the shipment inspection day
Surface-mounted type other than the hybrid type	S (hot lead-free reflow), HA (hot lead-free reflow) HB (hot lead-free reflow, 5.4 mm in height) HC, HD, FCA, FC, FKA, FK, FKS, FP, FT, FH, FN TG, TK, TP, TC, TCU, TQ	
Radial lead type other than the hybrid type	FC-A, FK-A, HD-A, TA-A, TP-A, FP-A	

- Avoid storing the capacitor in environments not specified in the delivery specification sheet or in the following environments or conditions.
 - (1) Used at a temperature higher than the upper limit category temperature or lower than the lower limit category temperature
 - (2) Environments where the capacitor is exposed to water, salt water, or oil
 - (3) Environments where dew concentrates on the capacitor
 - (4) Environments filled with a toxic gas (hydrogen sulfide, sulfurous acid, nitrous acid, chlorine and chlorine compound, bromine and bromine compound, ammonia, etc.)
 - (5) Environments where the product is exposed to ozone, radiation, UV-rays, etc.
 - (6) Environments where vibrations or mechanical shocks exceeding a specified range is applied to the capacitor

Reference information

Guidelines

Some of the product use guidelines described herein are excerpted from JEITA RCR-2367D "Safety application guide for fixed aluminum electrolytic capacitors for use in electronic equipment," a technical report issued by the Japan Electronics and Information Technology Industries Association on October 2017. For more detailed information, please see the above technical report.

Intellectual property

Panasonic Group provides customers with safe products and services. We are also making great efforts to protect our intellectual property rights for Panasonic Group products. Typical patents related to this product are as follows. (Hybrid type)

[U.S. patent]

USP Nos. 7497879, 7621970, 9208954, 9595396, 9966200, 10453618, 10559432, 10679800, 10685788, 10790095, 10262806, 10896783, 11348739, 11094471, 12062501, 10563318, 10865494, 10373763

Lineup

Surface mount type

Series	Part No.	Features	Small size	Large cap.	High ripple	High temp.	Long life	Category temperature range (°C)	Rated voltage range (V)	ESR (mΩ)	Capacitance range (μF)	Size code	Size (mm)	
													øD	L
ZA	EEHZA---	Low ESR High ripple current Long life 105 °C 10000 h	●					-55 to 105	25 to 50	80 to 120	10 to 33	C	5.0	5.8
									25 to 63	50 to 120	10 to 56	D	6.3	5.8
										30 to 80	22 to 100	D8	6.3	7.7
									25 to 80	27 to 45	22 to 220	F	8.0	10.2
20 to 36	33 to 330	G	10.0	10.2										
ZC	EEHZC---	Low ESR High ripple current Long life 125 °C 4000 h	●				-55 to 125	25 to 50	80 to 120	10 to 33	C	5.0	5.8	
								25 to 63	50 to 120	10 to 56	D	6.3	5.8	
									30 to 80	22 to 100	D8	6.3	7.7	
								25 to 80	27 to 45	22 to 220	F	8.0	10.2	
20 to 36	33 to 330	G	10.0	10.2										
ZK	EEHZK---	Large capacitance High ripple current Long life 125 °C 4000 h	●	●	●		-55 to 125	25 to 35	80 to 100	33 to 47	C	5.0	5.8	
									50 to 60	56 to 82	D	6.3	5.8	
									30 to 35	100 to 150	D8	6.3	7.7	
									27	180 to 270	F	8.0	10.2	
ZKU	EEHZK--U-	Large capacitance Long life 125 °C 4000 h	●	●	●		-55 to 125	25 to 35	80 to 100	39 to 56	C	5.0	5.8	
									50 to 60	68 to 100	D	6.3	5.8	
									30 to 35	120 to 180	D8	6.3	7.7	
									27	220 to 330	F	8.0	10.2	
ZL	EEHZL---	125 °C 4000 h 135 °C 4000 h	●	●	●		-55 to 135	25 to 35	58 to 60	47 to 82	C	5.0	5.8	
									38 to 40	82 to 150	D	6.3	5.8	
									24 to 26	150 to 220	D8	6.3	7.7	
									18 to 20	270 to 470	F	8.0	10.2	
ZT	EEHZT---	125 °C 4000 h 135 °C 4000 h		●	●		-55 to 135	25 to 63	14 to 16	470 to 680	G	10.0	10.2	
									22 to 32	33 to 220	F	8.0	10.2	
									16 to 25	56 to 330	G	10.0	10.2	
									25 to 35	22	220 to 330	F	8.0	10.2
16	390 to 560	G	10.0	10.2										
ZV	EEHZV---	125 °C 4000 h 135 °C 4000 h		●	●		-55 to 135	25 to 63	16 to 22	33 to 220	F	8.0	10.2	
									12 to 17	56 to 330	G	10.0	10.2	
ZVU	EEHZV--U-	125 °C 4000 h 135 °C 4000 h		●	●		-55 to 135	25 to 63	16 to 22	56 to 330	F	8.0	10.2	
									12 to 17	100 to 560	G	10.0	10.2	
ZS	EEHZS---	125 °C 4000 h 135 °C 4000 h		●	●		-55 to 135	25 to 63	14 to 19	100 to 470	G12	10.0	12.5	
									11 to 15	150 to 560	G16	10.0	16.5	
ZSU	EEHZS--U-	125 °C 4000 h 135 °C 4000 h		●	●		-55 to 135	25 to 63	14 to 19	120 to 680	G12	10.0	12.5	
									11 to 15	180 to 1000	G16	10.0	16.5	
ZU	EEHZU---	125 °C 4000 h 135 °C 4000 h		●	●		-55 to 135	25 to 63	10 to 12	100 to 470	G12	10.0	12.5	
									8 to 10	150 to 560	G16	10.0	16.5	
ZUU	EEHZU--U-	125 °C 4000 h 135 °C 4000 h		●	●		-55 to 135	25 to 63	10 to 12	120 to 680	G12	10.0	12.5	
									8 to 10	180 to 1000	G16	10.0	16.5	
ZE	EEHZE---	145 °C 2000 h 135 °C 4000 h			●	●	-55 to 145	25 to 63	27 to 40	33 to 220	F	8.0	10.2	
									20 to 30	56 to 330	G	10.0	10.2	
ZF	EEHZF---	150 °C 1000 h			●	●	-55 to 150	25 to 63	27 to 40	33 to 150	F	8.0	10.2	
									20 to 30	56 to 270	G	10.0	10.2	

Line up

Radial lead type

Series	Part No.	Features	Small size	Large cap.	High ripple	High temp.	Long life	Category temperature range (°C)	Rated voltage range (V)	ESR (mΩ)	Capacitance range (μF)	Size code	Size (mm)	
													∅D	L
ZA-A	EEHAZA---B	105 °C 10000 h						-55 to 105	25 to 80	27 to 45	22 to 220	F	8.0	9.5
										20 to 36	33 to 330	G	10.0	9.5
ZC-A	EEHAZC---B	125 °C 4000 h					●	-55 to 125	25 to 80	27 to 45	22 to 220	F	8.0	9.5
										20 to 36	33 to 330	G	10.0	9.5
ZK-A	EEHAZK---B	125 °C 4000 h		●	●			-55 to 125	25 to 35	27	180 to 270	F	8.0	9.5
										20	330 to 470	G	10.0	9.5
ZKU-A	EEHAZK--UB	125 °C 4000 h		●	●			-55 to 125	25 to 35	27	220 to 330	F	8.0	9.5
										20	390 to 560	G	10.0	9.5
ZT-A	EEHAZT---B	125 °C 4000 h		●	●			-55 to 135	25 to 63	22 to 32	33 to 220	F	8.0	9.5
		135 °C 4000 h								16 to 25	56 to 330	G	10.0	9.5
ZS-A	EEHAZS---B	125 °C 4000 h		●	●			-55 to 135	25 to 63	14 to 19	100 to 470	G12	10.0	11.7
		135 °C 4000 h								11 to 15	150 to 560	G16	10.0	15.7
ZSU-A	EEHAZS--UB	125 °C 4000 h		●	●			-55 to 135	25 to 63	14 to 19	120 to 680	G12	10.0	11.7
		135 °C 4000 h								11 to 15	180 to 1000	G16	10.0	15.7
ZE-A	EEHAZE---B	145 °C 2000 h				●	●	-55 to 145	25 to 63	27 to 40	33 to 220	F	8.0	9.5
		135 °C 4000 h								20 to 30	56 to 330	G	10.0	9.5
ZF-A	EEHAZF---B	150 °C 1000 h				●	●	-55 to 150	25 to 63	27 to 40	33 to 150	F	8.0	9.5
										20 to 30	56 to 270	G	10.0	9.5

Series flow chart

● Surface mount type

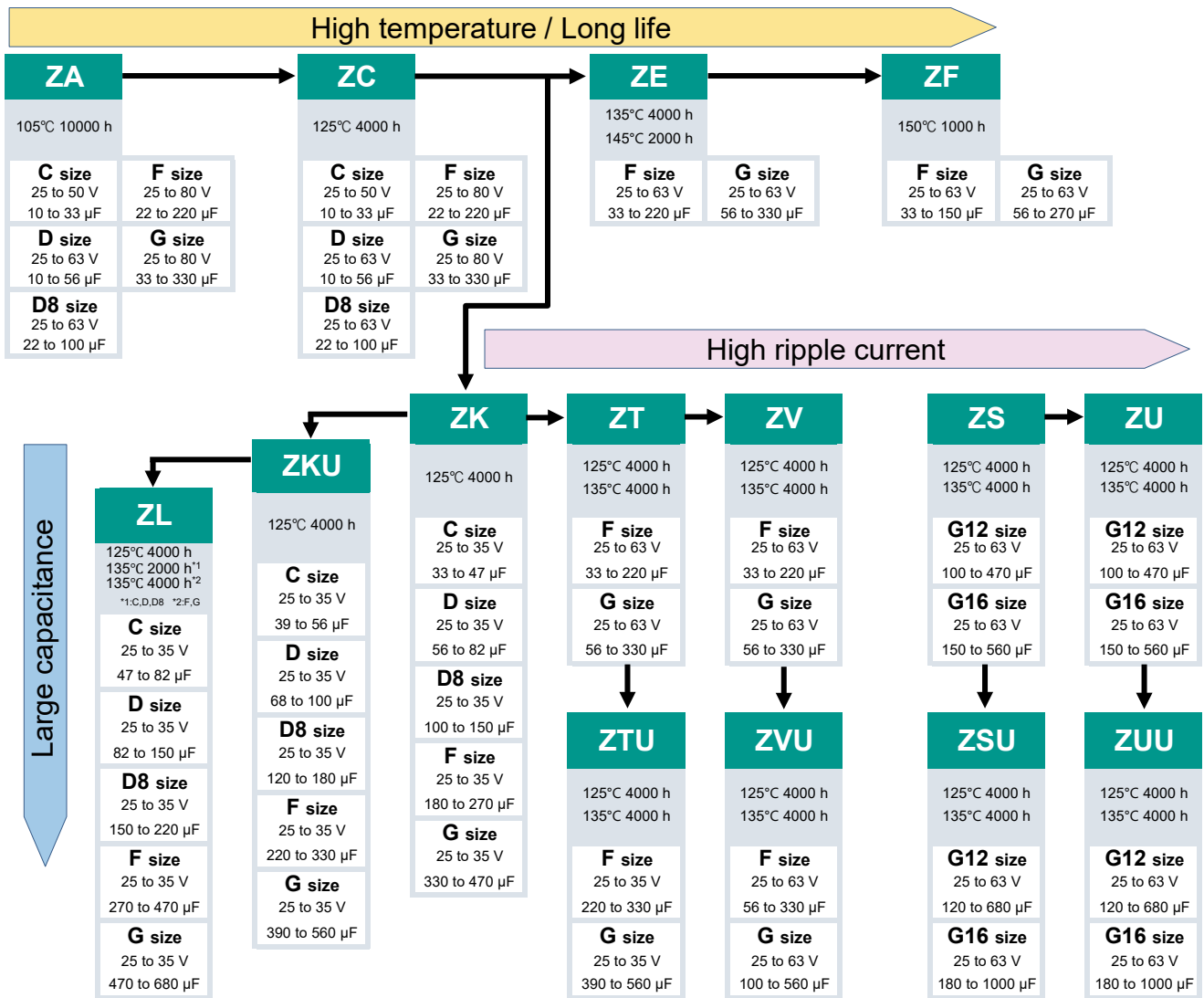

● Radial lead type

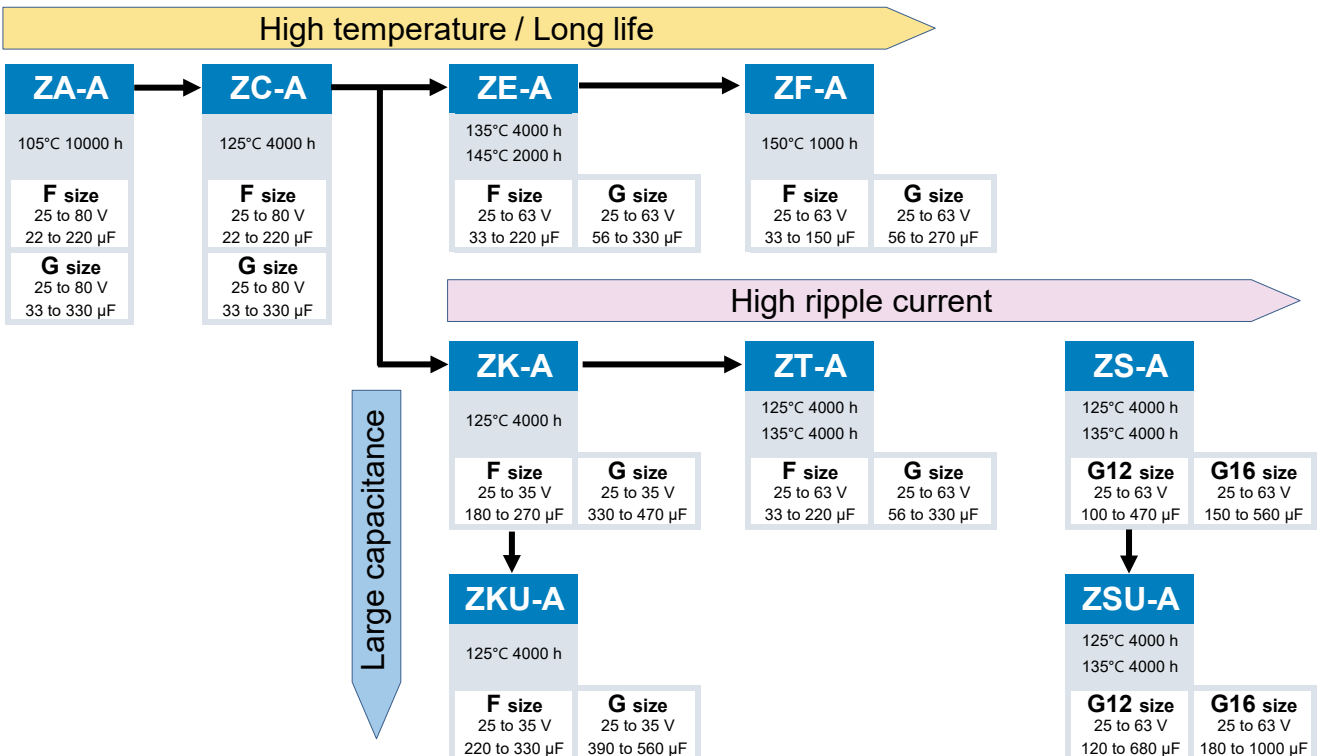

Voltage - Capacitance table (SMD type) (Vol. : 25 to 80 V / Cap. : 10 to 120 μF)

Series [Size]
(ESR mΩ)

W	μF	10	22	27	33	39	47	56	68	82	100	120
25			ZA [C] (80)		ZA [C] (80)		ZA [D] (50)	ZA [D] (50)	ZA [D8] (30)	ZK [D] (50)	ZA [D8] (30)	
			ZC [C] (80)		ZC [C] (80)		ZC [D] (50)	ZC [D] (50)	ZC [D8] (30)	ZL [C] (58)	ZC [D8] (30)	
							ZK [C] (80)	ZKU [C] (80)	ZK [D] (50)		ZKU [D] (50)	
35		ZA [C] (100)	ZA [C] (100)	ZA [D] (60)	ZA [D] (60)	ZKU [C] (100)	ZA [D] (60)	ZK [D] (60)	ZA [D8] (35)	ZL [D] (40)	ZA [F] (27)	ZKU [D8] (35)
		ZC [C] (100)	ZC [C] (100)		ZC [D] (60)		ZC [D] (60)		ZC [D8] (35)		ZC [F] (27)	
					ZK [C] (100)		ZL [C] (60)		ZKU [D] (60)		ZK [D8] (35)	
											ZF [F] (30)	
50		ZA [C] (120)	ZA [D] (80)		ZA [D8] (40)		ZA [F] (30)	ZF [F] (35)	ZA [F] (30)	ZVU [F] (19)	ZA [G] (28)	ZC [G] (28)
		ZC [C] (120)	ZC [D] (80)		ZC [D8] (40)		ZC [F] (30)		ZC [F] (30)		ZC [G] (28)	ZT [G] (23)
									ZT [F] (25)		ZT [G] (23)	ZV [G] (15)
									ZE [F] (30)		ZE [G] (28)	
									ZV [F] (19)		ZF [G] (28)	
											ZV [G] (15)	
63		ZA [D] (120)	ZA [D8] (80)		ZA [F] (40)		ZA [F] (40)	ZA [G] (30)	ZA [G] (30)	ZA [G] (30)	ZS [G12] (19)	ZSU [G12] (19)
		ZC [D] (120)	ZC [D8] (80)		ZC [F] (40)		ZC [F] (40)	ZC [G] (30)	ZC [G] (30)	ZC [G] (30)	ZU [G12] (12)	ZUU [G12] (12)
					ZT [F] (32)		ZT [F] (32)	ZT [G] (25)	ZT [G] (25)	ZT [G] (25)	ZVU [G] (17)	
					ZE [F] (40)		ZV [F] (22)	ZE [G] (30)	ZV [G] (17)	ZE [G] (30)		
					ZF [F] (40)			ZF [G] (30)		ZV [G] (17)		
					ZV [F] (22)			ZV [G] (17)	ZVU [F] (22)			
80			ZA [F] (45)		ZA [G] (36)		ZA [G] (36)					
			ZC [F] (45)		ZC [G] (36)		ZC [G] (36)					

Size list ø x L (mm)

C	5.0x5.8	D	6.3x5.8	F	8.0x10.2	G	10.0x10.2
		D8	6.3x7.7			G12	10.0x12.5
						G16	10.0x16.5

Voltage - Capacitance table (SMD type) (Vol. : 25 to 80 V / Cap. : 150 to 1000 µF)

Series [Size]
(ESR mΩ)

V	µF	150	180	220	270	330	390	470	560	680	1000
25		ZA [F] (27)	ZKU [D8] (30)	ZA [F] (27)	ZK [F] (27)	ZA [G] (20)		ZK [G] (20)	ZKU [G] (20)	ZSU [G12] (14)	ZSU [G16] (11)
		ZC [F] (27)		ZC [F] (27)	ZF [G] (20)	ZC [G] (20)		ZS [G12] (14)	ZS [G16] (11)	ZUU [G12] (10)	ZUU [G16] (8)
		ZK [D8] (30)		ZT [F] (22)		ZKU [F] (27)		ZU [G12] (10)	ZU [G16] (8)	ZL [G] (14)	
		ZF [F] (27)		ZE [F] (27)		ZT [G] (16)		ZL [F] (18)	ZTU [G] (16)		
		ZL [D] (38)		ZV [F] (16)		ZE [G] (20)			ZVU [G] (12)		
				ZL [D8] (24)		ZTU [F] (22)					
						ZV [G] (12)					
						ZVU [F] (16)					
35		ZA [F] (27)	ZK [F] (27)	ZA [G] (20)	ZA [G] (20)	ZK [G] (20)	ZKU [G] (20)	ZS [G16] (11)		ZSU [G16] (11)	
		ZC [F] (27)		ZC [G] (20)	ZC [G] (20)	ZS [G12] (14)	ZTU [G] (16)	ZSU [G12] (14)		ZUU [G16] (9)	
		ZT [F] (22)		ZKU [F] (27)	ZT [G] (16)	ZU [G12] (11)	ZVU [G] (12)	ZU [G16] (9)			
		ZE [F] (27)		ZTU [F] (22)	ZE [G] (20)			ZUU [G12] (11)			
		ZF [G] (23)		ZVU [F] (16)	ZV [G] (12)			ZL [G] (16)			
		ZV [F] (16)			ZL [F] (20)						
		ZL [D8] (26)									
50		ZS [G12] (17)	ZSU [G12] (17)	ZS [G16] (13)	ZSU [G16] (13)						
		ZU [G12] (12)	ZUU [G12] (12)	ZU [G16] (10)	ZUU [G16] (10)						
		ZVU [G] (15)									
63		ZS [G16] (15)	ZSU [G16] (15)								
		ZU [G16] (10)	ZUU [G16] (10)								
80											

Size list ø x L (mm)

C	5.0x5.8	D	6.3x5.8	F	8.0x10.2	G	10.0x10.2
		D8	6.3x7.7			G12	10.0x12.5
						G16	10.0x16.5

Voltage - Capacitance table (Radial lead type) (Vol. : 25 to 80 V / Cap. : 22 to 150 μ F)

Series [Size]
(ESR m Ω)

V	μ F	22	27	33	39	47	56	68	82	100	120	150
25												ZA [F] (27)
												ZC [F] (27)
												ZF [F] (27)
35										ZA [F] (27)		ZA [F] (27)
										ZC [F] (27)		ZC [F] (27)
										ZF [F] (30)		ZK [F] (22)
												ZE [F] (27)
												ZF [G] (23)
50						ZA [F] (30)	ZF [F] (35)	ZA [F] (30)		ZA [G] (28)	ZC [G] (28)	ZS [G12] (17)
						ZC [F] (30)		ZC [F] (30)		ZC [G] (28)	ZT [G] (23)	
								ZT [F] (25)		ZT [G] (23)		
								ZE [F] (30)		ZE [G] (28)		
										ZF [G] (28)		
63			ZA [F] (40)			ZA [F] (40)	ZA [G] (30)	ZA [G] (30)	ZA [G] (30)	ZS [G12] (19)	ZSU [G12] (19)	ZS [G16] (15)
			ZC [F] (40)			ZC [F] (40)	ZC [G] (30)	ZC [G] (30)	ZC [G] (30)			
			ZT [F] (32)			ZT [F] (32)	ZT [G] (25)	ZT [G] (25)	ZT [G] (25)			
			ZE [F] (40)				ZE [G] (30)		ZE [G] (30)			
			ZF [F] (40)				ZF [G] (30)					
80		ZA [F] (45)		ZA [G] (36)		ZA [G] (36)						
		ZC [F] (45)		ZC [G] (36)		ZC [G] (36)						

Size list ϕ x L (mm)

F	8.0 x 9.5	G	10.0 x 9.5	G12	10.0 x 11.7	G16	10.0 x 15.7
---	-----------	---	------------	-----	-------------	-----	-------------

Voltage - Capacitance table (Radial lead type) (Vol. : 25 to 80 V / Cap. : 180 to 1000 μF)

Series [Size]
(ESR mΩ)

V	μF	180	220	270	330	390	470	560	680	1000
25			ZA [F] (27)	ZK [F] (27)	ZA [G] (20)		ZK [G] (20)	ZKU [G] (20)	ZSU [G12] (14)	ZSU [G16] (11)
			ZC [F] (27)	ZF [G] (20)	ZC [G] (20)		ZS [G12] (14)	ZS [G16] (11)		
			ZT [F] (22)		ZKU [F] (27)					
			ZE [F] (27)		ZT [G] (16)					
					ZE [G] (20)					
35		ZK [F] (27)	ZA [G] (20)	ZA [G] (20)	ZK [G] (20)	ZKU [G] (20)	ZS [G16] (11)		ZSU [G16] (11)	
			ZC [G] (20)	ZC [G] (20)	ZS [G12] (14)		ZSU [G12] (14)			
			ZKU [F] (27)	ZT [G] (16)						
				ZE [G] (20)						
50		ZSU [G12] (17)	ZS [G16] (13)	ZSU [G16] (13)						
63		ZSU [G16] (15)								
80										

Size list ø x L (mm)

F	8.0 x 9.5	G	10.0 x 9.5	G12	10.0 x 11.7	G16	10.0 x 15.7
---	-----------	---	------------	-----	-------------	-----	-------------

Explanation of part numbers

◇ Part number system

• Surface mount type

EEH Product classification 3 figures	ZC Series 2 figures	1E Voltage code 1 to 2 figures	101 Capacitance code 3 figures	X Size code 0 to 1 figure	* Special code 0 to 1 figure	P Taping/ Special code 1 figure
	Series Code	Rated voltage (V) Code	Cap. (μF) Code	øD x L Code	Dia øD Code	Tape width (mm) Code
	ZA ZA ZC ZC ZK ZK ZKU ZK ZL ZL ZT ZT ZTU ZT ZV ZV ZVU ZV ZS ZS ZSU ZS ZU ZU ZUU ZU ZE ZE ZF ZF	25 1E 35 1V 50 1H 63 1J 80 1K	10 100 22 220 27 270 33 330 39 390 47 470 56 560 68 680 82 820 100 101 120 121 150 151 180 181 220 221 270 271 330 331 390 391 470 471 560 561 680 681 1000 102	6.3 x 7.7 (D8) X	Minia- turization product U	12 R 16, 24 P
				* Only D8 is marked with X		Replace for the following configuration
						Configuration Code Vibration proof V

* If the total figures number of the part number exceeds 12 figures, "1" is omitted.
e.g.) 1E → E

• Radial lead type

EEHA Product classification 4 figures	ZC Series 2 figures	1E Voltage code 1 to 2 figure	151 Capacitance code 3 figures	* Special code 0 to 1 figure	B Taping code 1 figure
	Series Code	Rated voltage (V) Code	Cap. (μF) Code	Dia øD Code	Lead space (mm) Code
	ZA ZA ZC ZC ZK ZK ZKU ZK ZT ZT ZS ZS ZSU ZS ZE ZE ZF ZF	25 1E 35 1V 50 1H 63 1J 80 1K	22 220 33 330 47 470 56 560 68 680 82 820 100 101 120 121 150 151 180 181 220 221 270 271 330 331 390 391 470 471 560 561 680 681 1000 102	Minia- turization product U	3.5, 5.0 B

* If the total figures number of the part number exceeds 12 figures, "1" is omitted.
e.g.) 1E → E

Recommended reflow soldering

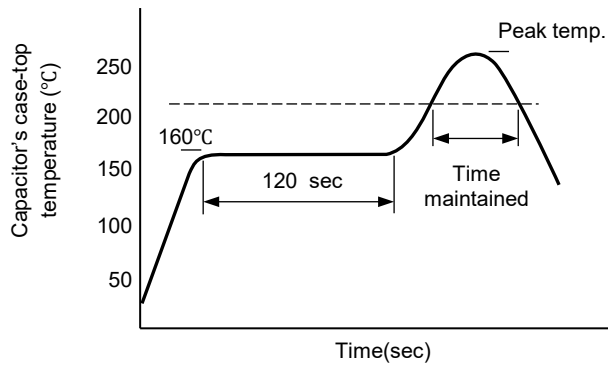

Size code	C, D, D8	F, G, G12, G16	
Peak temp.	260°C (255°C)	245°C	260°C
Time in peak temperature	≥ 250°C 5 s (10 s)	≥ 240°C 10 s	≥ 250°C 5 s
Time maintained	≥ 230°C 30 s	≥ 230°C 30 s	≥ 230°C 30 s
	≥ 217°C 40 s	≥ 217°C 40 s	≥ 217°C 40 s
	≥ 200°C 70 s	≥ 200°C 70 s	≥ 200°C 70 s
Reflow cycles	2 times	2 times	1 time

* For reflow, use a thermal condition system such as infrared and radiation (IR) or hot blas.

* Reflow temperature is measured on capacitor's case top.

Specifications for radial lead type

- Flow soldering condition
- < RoHS compliant >

	Temperature	Time	Flow number
Soldering condition	260°C + 5°C or less	10 sec +1 sec or less	1 time

Dimensions (Vibration-proof products)

The size and shape are different from standard products.

< Size code : D, D8 >

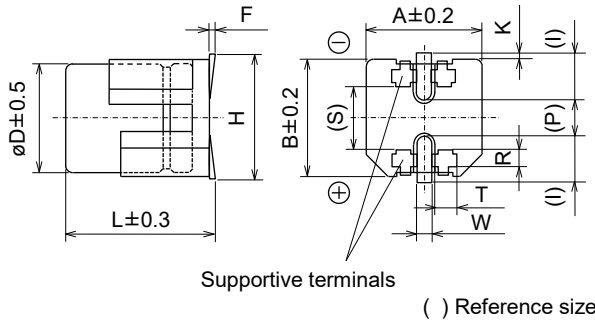

Unit : mm

Size code	øD	L	A, B	H max.	F	I	W
D	6.3	6.1	6.6	7.8	0 to +0.15	2.4	0.65±0.1
D8	6.3	8.0	6.6	7.8	0 to +0.15	2.4	0.65±0.1

Size code	P	K	R	S	T
D	2.2	0.35 ^{+0.15} _{-0.20}	1.1±0.2	3.3	1.05±0.2
D8	2.2	0.35 ^{+0.15} _{-0.20}	1.1±0.2	3.3	1.05±0.2

< Size code : F, G, G12, G16 >

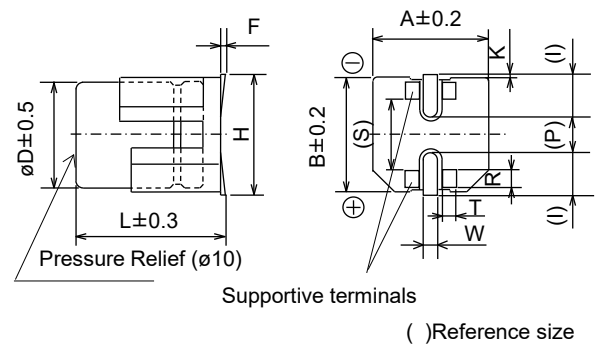

Unit : mm

Size code	øD	L	A, B	H max.	F	I	W
F	8.0	10.5	8.3	10.0	0 to +0.15	3.4	1.2±0.2
G	10.0	10.5	10.3	12.0	0 to +0.15	3.5	1.2±0.2
G12	10.0	12.8	10.3	11.0 ^{*1}	0 to +0.15	3.2	1.2±0.2
G16	10.0	16.8	10.3	11.0 ^{*1}	0 to +0.15	3.2	1.2±0.2

^{*1}:±0.2

Size code	P	K	R	S	T
F	3.1	0.70±0.2	0.70±0.2	5.3	1.3±0.2
G	4.6	0.70±0.2	0.70±0.2	6.9	1.3±0.2
G12	4.6	—	0.70±0.2	6.9	1.3±0.2
G16	4.6	—	0.70±0.2	6.9	1.3±0.2

Mounting specification

Land / Pad pattern

The circuit board land/pad pattern size for chip capacitors is specified in the following table.
The land pitch influences installation strength.

● Standard products

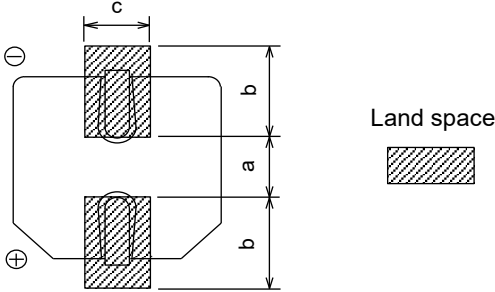

Unit : mm

Size code	a	b	c
C : $\phi 5 \times L5.8$	1.5	2.8	1.6
D : $\phi 6.3 \times L5.8$	1.8	3.2	1.6
D8 : $\phi 6.3 \times L7.7$	1.8	3.2	1.6
F : $\phi 8 \times L10.2$	3.1	4.0	2.0
G : $\phi 10 \times L10.2$	4.6	4.1	2.0
G12 : $\phi 10 \times L12.5$	4.6	4.1	2.0
G16 : $\phi 10 \times L16.5$	4.6	4.1	2.0

Larger dimension of "a" may prevent back fillet from being formed adequately to obtain required solder strength.

* Take mounting conditions, solderability and fitting strength into consideration when selecting parts for your design.

● Vibration-proof products

< Size code : D, D8 >

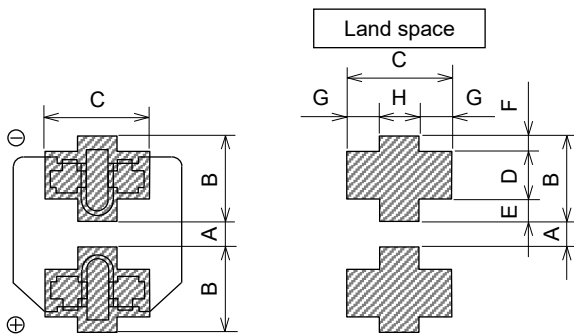

Unit : mm

Size code	A	B	C	D
D : $\phi 6.3 \times L6.1$	1.2	3.6	3.2	2.0
D8 : $\phi 6.3 \times L8.0$	1.2	3.6	3.2	2.0

Size code	E	F	G	H
D : $\phi 6.3 \times L6.1$	0.95	0.65	1.0	1.2
D8 : $\phi 6.3 \times L8.0$	0.95	0.65	1.0	1.2

Larger dimension of "A" may prevent back fillet from being formed adequately to obtain required solder strength.

< Size code : F, G, G12, G16 >

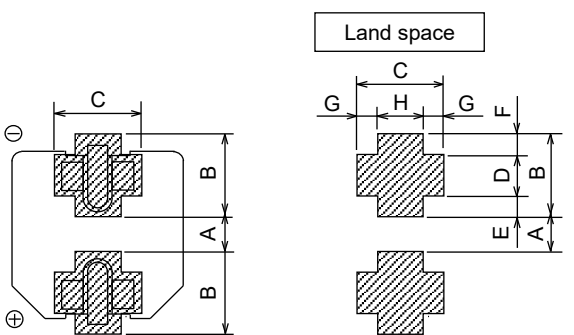

Unit : mm

Size code	A	B	C	D
F : $\phi 8 \times L10.5$	2.7	4.0	4.7	1.3
G : $\phi 10 \times L10.5$	3.9	4.4	4.7	1.3
G12 : $\phi 10 \times L12.8$	3.9	4.4	4.7	1.3
G16 : $\phi 10 \times L16.8$	3.9	4.4	4.7	1.3

Size code	E	F	G	H
F : $\phi 8 \times L10.5$	1.0	1.7	1.1	2.5
G : $\phi 10 \times L10.5$	1.2	1.9	1.1	2.5
G12 : $\phi 10 \times L12.8$	1.2	1.9	1.1	2.5
G16 : $\phi 10 \times L16.8$	1.2	1.9	1.1	2.5

Larger dimension of "A" may prevent back fillet from being formed adequately to obtain required solder strength.

* Take mounting conditions, solderability and fitting strength into consideration when selecting parts for your design.

* The vibration-proof capacitors of size $\phi 6.3$ has support terminals extending from the bottom side to the lead edge. Then, make sure to find appropriate soldering conditions to form fillet on the support terminals if required for appearance inspection.

Packaging specifications

Specifications for surface mount type

● Reel dimensions (not to scale)

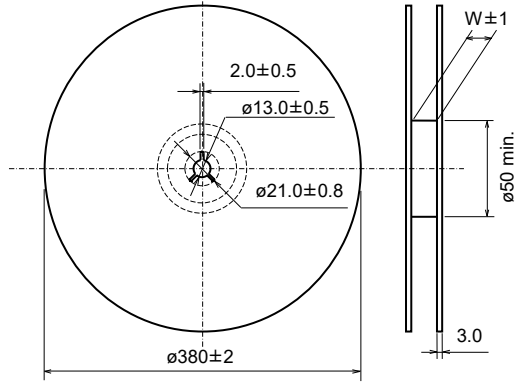

Unit : mm

Size code	W
C	14.0
D, D8	18.0
F, G, G12, G16	26.0

● Dimensions of outer carton box

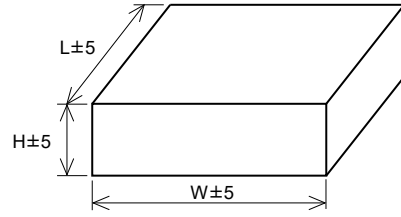

Unit : mm

Size code	H	W, L
C	180	395
D, D8	220	395
F, G, G12, G16	180	395

● Min.packing quantity

Size code	Min.packing quantity (pcs.)
C, D	1000
D8	900
F, G	500
G12	400
G16	250

● Taping dimensions

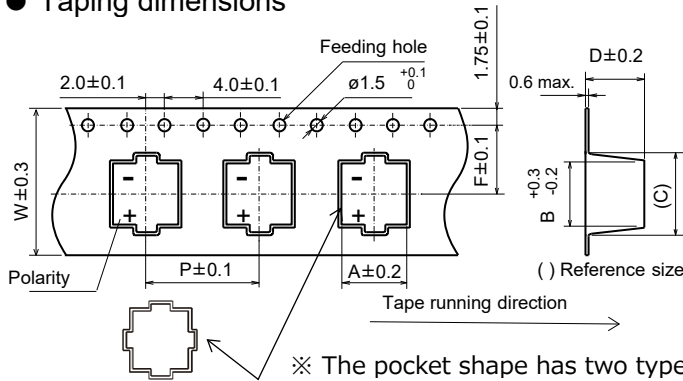

Unit : mm

Size code	A	B	C	D	P	F	W
C	5.7	5.7	8.0	6.4	12.0	5.5	12.0
D	7.0	7.0	9.0	6.4	12.0	7.5	16.0
D8	7.0	7.0	9.0	8.4	12.0	7.5	16.0
F	8.7	8.7	12.5	11.0	16.0	11.5	24.0
G	10.7	10.7	14.5	11.0	16.0	11.5	24.0
G12	10.7	10.7	14.5	13.7	16.0	11.5	24.0
G16	10.7	10.7	14.5	17.5	20.0	11.5	24.0

Radial lead type

● Taping dimensions

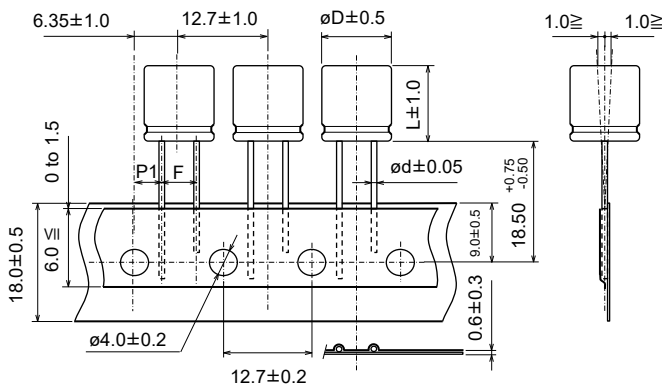

Unit : mm

Size code	ϕD	L	ϕd	F	P1
F	8.0	9.5	0.6	3.5 ± 0.5	4.60 ± 0.50
G	10.0	9.5	0.6	$5.0 + 0.8 / - 0.2$	3.85 ± 0.50
G12	10.0	11.7	0.8	$5.0 + 0.8 / - 0.2$	3.85 ± 0.50
G16	10.0	15.7	0.8	$5.0 + 0.8 / - 0.2$	3.85 ± 0.50

● Dimensions of outer carton box / Packaging method

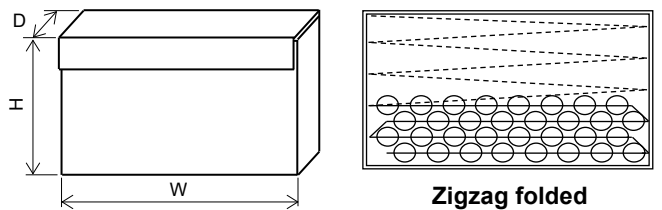

Unit : mm

Size code	W	H	D
F	340 max.	230 max.	55 max.
G	340 max.	170 max.	55 max.
G12	340 max.	170 max.	55 max.
G16	340 max.	170 max.	55 max.

● Min.packing quantity

Size code	Min.packing quantity (pcs.)
F	1000
G	500
G12	500
G16	500

Conductive Polymer Hybrid Aluminum Electrolytic Capacitors

Surface Mount Type

ZA series

High temperature lead-free reflow

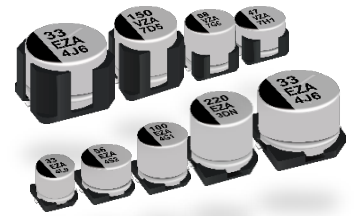

Features

- Endurance : 10000 h at 105 °C
- Low ESR and high ripple current (over 70% lower ESR and 100% higher ripple current than V-FP)
- High voltage (to 80 V)
- Characteristics dependencies in frequency and low temperature are as small as polymer type
- Vibration-proof product is available upon request (ø6.3, ø8, ø10)
- AEC-Q200 compliant
- RoHS compliant

Specifications

Size code	C	D	D8	F	G
Category temp. range	-55 °C to +105 °C				
Rated voltage range	25 V to 50 V	25 V to 63 V		25 V to 80 V	
Nominal capacitance range	10 µF to 33 µF	10 µF to 56 µF	22 µF to 100 µF	22 µF to 220 µF	33 µF to 330 µF
Capacitance tolerance	±20 % (120 Hz / +20 °C)				
Leakage current	$I \leq 0.01 CV$ (µA), 2 minutes after reaching rated voltage, 20 °C *CV = (Capacitance in µF) x (Rated voltage in V)				
Dissipation factor (tan δ)	Please see the attached characteristics list				
Surge voltage (V)	Rated voltage × 1.25 (15 °C to 35 °C)				
Endurance	+105 °C ± 2 °C, 10000 h, apply the rated ripple current without exceeding the rated voltage.				
	Capacitance change	Within ±30% of the initial value			
	Dissipation factor (tan δ)	≤ 200 % of the initial limit			
	ESR	≤ 200 % of the initial limit			
	Leakage current	Within the initial limit			
ESR after endurance (Ω / 100 kHz)(-40 °C)	Size code				
	C	D	D8	F	G
	2.0	1.4	0.8	0.4	0.3
Shelf life	After storage for 1000 hours at +105 °C ± 2 °C with no voltage applied and then being stabilized at +20 °C, capacitors shall meet the limits specified in endurance.				
	(Capacitors are left at room temperature and humidity for 2 hours after the test. Then, apply the rated voltage for 30min with a series protection resistance of 1000 Ω ± 10 Ω. Measure electrical characteristics after discharging the capacitor.)				
Damp heat (Load)	+85 °C ± 2 °C, 85 % to 90 %RH, 2000 h, rated voltage applied				
	Capacitance change	Within ±30% of the initial value			
	Dissipation factor (tan δ)	≤ 200 % of the initial limit			
	ESR	≤ 200 % of the initial limit			
	Leakage current	Within the initial limit			
Resistance to soldering heat	After reflow soldering and then being stabilized at +20 °C, capacitors shall meet the following limits.				
	Capacitance change	Within ±10% of the initial value			
	Dissipation factor (tan δ)	Within the initial limit			
	Leakage current	Within the initial limit			

Marking

Example : 25 V 33 µF
Marking color : BLACK

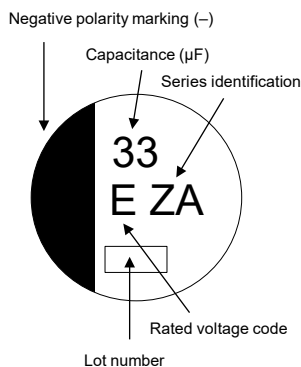

R. voltage code	Unit : V
E	25
V	35
H	50
J	63
K	80

Dimensions (not to scale)

[Standard]

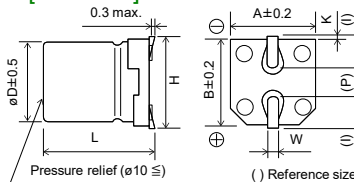

Size code	øD	L	A, B	H _{max.}	I	W	P	K
C	5.0	5.8±0.3	5.3	6.5	2.2	0.65±0.1	1.5	0.35 ^{+0.15} _{-0.20}
D	6.3	5.8±0.3	6.6	7.8	2.6	0.65±0.1	1.8	0.35 ^{+0.15} _{-0.20}
D8	6.3	7.7±0.3	6.6	7.8	2.6	0.65±0.1	1.8	0.35 ^{+0.15} _{-0.20}
F	8.0	10.2±0.3	8.3	10	3.4	0.90±0.2	3.1	0.70±0.2
G	10.0	10.2±0.3	10.3	12.0	3.5	0.90±0.2	4.6	0.70±0.2

Unit : mm

[Vibration-proof product]

< Size code : D, D8 >

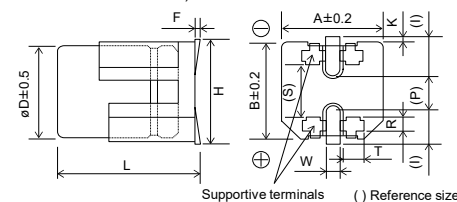

Size code	øD	L	A, B	H _{max.}	F	I	W	P	K	R	S	T
D	6.3	6.1±0.3	6.6	7.8	0 to +0.15	2.4	0.65±0.1	2.2	0.35 ^{+0.15} _{-0.20}	1.1±0.2	3.3	1.05±0.2
D8	6.3	8.0±0.3	6.6	7.8	0 to +0.15	2.4	0.65±0.1	2.2	0.35 ^{+0.15} _{-0.20}	1.1±0.2	3.3	1.05±0.2
F	8.0	10.5±0.3	8.3	10.0	0 to +0.15	3.4	1.2±0.2	3.1	0.70±0.2	0.70±0.2	5.3	1.3±0.2
G	10.0	10.5±0.3	10.3	12.0	0 to +0.15	3.5	1.2±0.2	4.6	0.70±0.2	0.70±0.2	6.9	1.3±0.2

Unit : mm

Explanation of part numbers

◆ **Part number system**

e.g.: EEHZA1E220R

EEH	ZA		1E		220				X		R	
Product classification	Series	Code	Rated voltage (V)	Code *	Capacitance (μF)	Code	Capacitance (μF)	Code	D8 size** øDxL(mm)	Code	Tape width (mm)	Code
	ZA	ZA	25	1E	10	100	68	680	6.3 x 7.7	X	12	R
			35	1V	22	220	100	101			16, 24	P
			50	1H	27	270	150	151				
			63	1J	33	330	220	221				
			80	1K	39	390	270	271				
					47	470	330	331				
					56	560						

*: If the total figures number of the part number exceeds 12 figures, "1" is omitted.

**: Only D8 is marked with X

Replace for the following configuration	
Configuration	Code
Vibration proof	V

Characteristics list

Endurance : 105 °C 10000 h

Rated voltage (V)	Capacitance (±20 %) (μF)	Case size (mm)			Size code	Specification			Part number		Min. packaging qty (pcs)
		øD	L			Ripple current*1 (mA rms)	ESR*2 (mΩ)	tan δ*3	Standard product	Vibration-proof product	Taping
			Standard	Vibration-proof							
25	22	5.0	5.8	-	C	900	80	0.14	EEHZA1E220R	-	1000
	33	5.0	5.8	-	C	900	80	0.14	EEHZA1E330R	-	1000
	47	6.3	5.8	6.1	D	1300	50	0.14	EEHZA1E470P	EEHZA1E470V	1000
	56	6.3	5.8	6.1	D	1300	50	0.14	EEHZA1E560P	EEHZA1E560V	1000
	68	6.3	7.7	8.0	D8	2000	30	0.14	EEHZA1E680XP	EEHZA1E680XV	900
	100	6.3	7.7	8.0	D8	2000	30	0.14	EEHZA1E101XP	EEHZA1E101XV	900
	150	8.0	10.2	10.5	F	2300	27	0.14	EEHZA1E151P	EEHZA1E151V	500
	220	8.0	10.2	10.5	F	2300	27	0.14	EEHZA1E221P	EEHZA1E221V	500
35	330	10.0	10.2	10.5	G	2500	20	0.14	EEHZA1E331P	EEHZA1E331V	500
	10	5.0	5.8	-	C	900	100	0.12	EEHZA1V100R	-	1000
	22	5.0	5.8	-	C	900	100	0.12	EEHZA1V220R	-	1000
	27	6.3	5.8	6.1	D	1300	60	0.12	EEHZA1V270P	EEHZA1V270V	1000
	33	6.3	5.8	6.1	D	1300	60	0.12	EEHZA1V330P	EEHZA1V330V	1000
	47	6.3	5.8	6.1	D	1300	60	0.12	EEHZA1V470P	EEHZA1V470V	1000
	68	6.3	7.7	8.0	D8	2000	35	0.12	EEHZA1V680XP	EEHZA1V680XV	900
	100	8.0	10.2	10.5	F	2300	27	0.12	EEHZA1V101P	EEHZA1V101V	500
50	150	8.0	10.2	10.5	F	2300	27	0.12	EEHZA1V151P	EEHZA1V151V	500
	220	10.0	10.2	10.5	G	2500	20	0.12	EEHZA1V221P	EEHZA1V221V	500
	270	10.0	10.2	10.5	G	2500	20	0.12	EEHZA1V271P	EEHZA1V271V	500
	10	5.0	5.8	-	C	750	120	0.10	EEHZA1H100R	-	1000
	22	6.3	5.8	6.1	D	1100	80	0.10	EEHZA1H220P	EEHZA1H220V	1000
	33	6.3	7.7	8.0	D8	1600	40	0.10	EEHZA1H330XP	EEHZA1H330XV	900
	47	8.0	10.2	10.5	F	1800	30	0.10	EEHZA1H470P	EEHZA1H470V	500
	68	8.0	10.2	10.5	F	1800	30	0.10	EEHZA1H680P	EEHZA1H680V	500
63	100	10.0	10.2	10.5	G	2000	28	0.10	EEHZA1H101P	EEHZA1H101V	500
	10	6.3	5.8	6.1	D	1000	120	0.08	EEHZA1J100P	EEHZA1J100V	1000
	22	6.3	7.7	8.0	D8	1500	80	0.08	EEHZA1J220XP	EEHZA1J220XV	900
	33	8.0	10.2	10.5	F	1700	40	0.08	EEHZA1J330P	EEHZA1J330V	500
	47	8.0	10.2	10.5	F	1700	40	0.08	EEHZA1J470P	EEHZA1J470V	500
	56	10.0	10.2	10.5	G	1800	30	0.08	EEHZA1J560P	EEHZA1J560V	500
	68	10.0	10.2	10.5	G	1800	30	0.08	EEHZA1J680P	EEHZA1J680V	500
	82	10.0	10.2	10.5	G	1800	30	0.08	EEHZA1J820P	EEHZA1J820V	500
80	22	8.0	10.2	10.5	F	1550	45	0.08	EEHZA1K220P	EEHZA1K220V	500
	33	10.0	10.2	10.5	G	1700	36	0.08	EEHZA1K330P	EEHZA1K330V	500
	47	10.0	10.2	10.5	G	1700	36	0.08	EEHZA1K470P	EEHZA1K470V	500

*1: Ripple current (100 kHz / +105 °C)

*2: ESR (100 kHz / +20 °C)

*3: tan δ (120 Hz / +20 °C)

◆ Please refer to the page of "Reflow profile" and "The taping dimensions".

◆ The dimensions of the vibration-proof products, please refer to the page of the mounting specification.

Frequency correction factor for ripple current

Rated capacitance (C)	Frequency (f)	100 Hz ≤ f < 200 Hz	200 Hz ≤ f < 300 Hz	300 Hz ≤ f < 500 Hz	500 Hz ≤ f < 1 kHz
C < 47 μF	Correction factor	0.10	0.10	0.15	0.20
47 μF ≤ C < 150 μF		0.15	0.20	0.25	0.30
150 μF ≤ C		0.15	0.25	0.25	0.30
Rated capacitance (C)	Frequency (f)	1 kHz ≤ f < 2 kHz	2 kHz ≤ f < 3 kHz	3 kHz ≤ f < 5 kHz	5 kHz ≤ f < 10 kHz
C < 47 μF	Correction factor	0.30	0.40	0.45	0.50
47 μF ≤ C < 150 μF		0.40	0.45	0.55	0.60
150 μF ≤ C		0.45	0.50	0.60	0.65
Rated capacitance (C)	Frequency (f)	10 kHz ≤ f < 15 kHz	15 kHz ≤ f < 20 kHz	20 kHz ≤ f < 30 kHz	30 kHz ≤ f < 40 kHz
C < 47 μF	Correction factor	0.60	0.65	0.70	0.75
47 μF ≤ C < 150 μF		0.70	0.75	0.80	0.80
150 μF ≤ C		0.75	0.80	0.85	0.85
Rated capacitance (C)	Frequency (f)	40 kHz ≤ f < 50 kHz	50 kHz ≤ f < 100 kHz	100 kHz ≤ f < 500 kHz	500 kHz ≤ f
C < 47 μF	Correction factor	0.80	0.85	1.00	1.05
47 μF ≤ C < 150 μF		0.85	0.90	1.00	1.00
150 μF ≤ C		0.85	0.90	1.00	1.00

Conductive Polymer Hybrid Aluminum Electrolytic Capacitors
Surface Mount Type

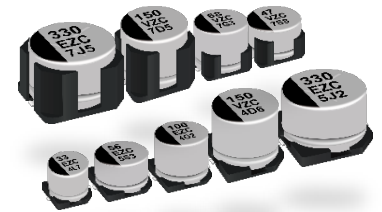

ZC series **High temperature lead-free reflow**

Features

- Endurance: 4000 h at 125 °C (High temperature / Long life)
- Low ESR and high ripple current (over 85% lower ESR than V-TP)
- High-withstand voltage (to 80 V)
- Characteristics dependencies in frequency and low temperature are as small as polymer type
- Vibration-proof product is available upon request (ø6.3, ø8, ø10)
- AEC-Q200 compliant
- RoHS compliant

Specifications

Size code	C	D	D8	F	G
Category temp. range	-55 °C to +125 °C				
Rated voltage range	25 V to 50 V	25 V to 63 V		25 V to 80 V	
Nominal capacitance range	10 µF to 33 µF	10 µF to 56 µF	22 µF to 100 µF	22 µF to 220 µF	33 µF to 330 µF
Capacitance tolerance	±20 % (120 Hz / +20 °C)				
Leakage current	I ≤ 0.01 CV (µA), 2 minutes after reaching rated voltage, 20 °C *CV = (Capacitance in µF) x (Rated voltage in V)				
Dissipation factor (tan δ)	Please see the attached characteristics list				
Surge voltage (V)	Rated voltage × 1.25 (15 °C to 35 °C)				
Endurance 1	+125 °C ± 2 °C, 4000 h, apply the rated ripple current without exceeding the rated voltage.				
	Capacitance change	Within ±30% of the initial value			
	Dissipation factor (tan δ)	≤ 200 % of the initial limit			
	ESR	≤ 200 % of the initial limit			
Endurance 2	+125 °C ± 2 °C, 3000 h, apply the rated ripple current without exceeding the rated voltage.				
	Capacitance change	Within ±30% of the initial value			
	Dissipation factor (tan δ)	≤ 200 % of the initial limit			
	ESR	≤ 300 % of the initial limit			
Shelf life	After storage for 1000 hours at +125 °C ± 2 °C with no voltage applied and then being stabilized at +20 °C, capacitors shall meet the limits specified in endurance. (Capacitors are left at room temperature and humidity for 2 hours after the test. Then, apply the rated voltage for 30min with a series protection resistance of 1000 Ω ± 10 Ω. Measure electrical characteristics after discharging the capacitor.)				
	+85 °C ± 2 °C, 85 % to 90 %RH, 2000 h, rated voltage applied				
Damp heat (Load)	Capacitance change				
	Dissipation factor (tan δ)				
	ESR				
	Leakage current				
Resistance to soldering heat	After reflow soldering and then being stabilized at +20 °C, capacitors shall meet the following limits.				
	Capacitance change				
	Dissipation factor (tan δ)				
Leakage current					

Marking

Example : 25 V 33 µF
Marking color : BLACK
Negative polarity marking (-)

Capacitance (µF)
Series identification
Rated voltage code
Lot number

R. voltage code	Unit : V
E	25
V	35
H	50
J	63
K	80

Dimensions (not to scale)

[Standard]

Size code	øD	L	A, B	H max.	I	W	P	K
C	5.0	5.8±0.3	5.3	6.5	2.2	0.65±0.1	1.5	0.35 ^{+0.15} _{-0.20}
D	6.3	5.8±0.3	6.6	7.8	2.6	0.65±0.1	1.8	0.35 ^{+0.15} _{-0.20}
D8	6.3	7.7±0.3	6.6	7.8	2.6	0.65±0.1	1.8	0.35 ^{+0.15} _{-0.20}
F	8.0	10.2±0.3	8.3	10	3.4	0.90±0.2	3.1	0.70±0.2
G	10.0	10.2±0.3	10.3	12.0	3.5	0.90±0.2	4.6	0.70±0.2

[Vibration-proof product]
< Size code : D, D8 >

Size code	øD	L	A, B	H max.	F	I	W	P	K	R	S	T
D	6.3	6.1±0.3	6.6	7.8	0 to +0.15	2.4	0.65±0.1	2.2	0.35 ^{+0.15} _{-0.20}	1.1±0.2	3.3	1.05±0.2
D8	6.3	8.0±0.3	6.6	7.8	0 to +0.15	2.4	0.65±0.1	2.2	0.35 ^{+0.15} _{-0.20}	1.1±0.2	3.3	1.05±0.2
F	8.0	10.5±0.3	8.3	10.0	0 to +0.15	3.4	1.2±0.2	3.1	0.70±0.2	0.70±0.2	5.3	1.3±0.2
G	10.0	10.5±0.3	10.3	12.0	0 to +0.15	3.5	1.2±0.2	4.6	0.70±0.2	0.70±0.2	6.9	1.3±0.2

Explanation of part numbers

◆ Part number system e.g.: EEH^{ZC}1E²²⁰X^R

EEH	ZC		1E		220		X		R			
Product classification	Series	Code	Rated voltage (V)	Code *	Capacitance (μF)	Code	Capacitance (μF)	Code	D8 size** øDxL(mm)	Code	Tape width (mm)	Code
	ZC	ZC	25	1E	10	100	100	101	6.3 x 7.7	X	12	R
			35	1V	22	220	120	121			16 to 24	P
			50	1H	33	330	150	151				
			63	1J	47	470	220	221				
			80	1K	56	560	270	271				
					68	680	330	331				
					82	820						

*: If the total figures number of the part number exceeds 12 figures, "1" is omitted.
 **: Only D8 is marked with X

Replace for the following configuration	
Configuration	Code
Vibration proof	V

Characteristics list

Endurance 1 : 125 °C 4000 h

Endurance 2 : 125 °C 3000 h

Rated voltage (V)	Capacitance (±20 %) (μF)	Case size (mm)			Size code	Specification				Part number		Min. packaging q'ty (pcs)
		øD	L			Ripple current ^{*1} (mA rms)	ESR ^{*2} (mΩ)	tan δ ^{*3}	Standard product	Vibration-proof product	Taping	
			Standard	Vibration-proof								Endurance 1
25	22	5.0	5.8	–	C	550	–	80	0.14	EEH ^{ZC} 1E220R	–	1000
	33	5.0	5.8	–	C	550	–	80	0.14	EEH ^{ZC} 1E330R	–	1000
	47	6.3	5.8	6.1	D	900	–	50	0.14	EEH ^{ZC} 1E470P	EEH ^{ZC} 1E470V	1000
	56	6.3	5.8	6.1	D	900	–	50	0.14	EEH ^{ZC} 1E560P	EEH ^{ZC} 1E560V	1000
	68	6.3	7.7	8.0	D8	1400	–	30	0.14	EEH ^{ZC} 1E680XP	EEH ^{ZC} 1E680XV	900
	100	6.3	7.7	8.0	D8	1400	–	30	0.14	EEH ^{ZC} 1E101XP	EEH ^{ZC} 1E101XV	900
	150	8.0	10.2	10.5	F	1600	1900	27	0.14	EEH ^{ZC} 1E151P	EEH ^{ZC} 1E151V	500
	220	8.0	10.2	10.5	F	1600	1900	27	0.14	EEH ^{ZC} 1E221P	EEH ^{ZC} 1E221V	500
35	330	10.0	10.2	10.5	G	2000	2900	20	0.14	EEH ^{ZC} 1E331P	EEH ^{ZC} 1E331V	500
	10	5.0	5.8	–	C	550	–	100	0.12	EEH ^{ZC} 1V100R	–	1000
	22	5.0	5.8	–	C	550	–	100	0.12	EEH ^{ZC} 1V220R	–	1000
	33	6.3	5.8	6.1	D	900	–	60	0.12	EEH ^{ZC} 1V330P	EEH ^{ZC} 1V330V	1000
	47	6.3	5.8	6.1	D	900	–	60	0.12	EEH ^{ZC} 1V470P	EEH ^{ZC} 1V470V	1000
	68	6.3	7.7	8.0	D8	1400	–	35	0.12	EEH ^{ZC} 1V680XP	EEH ^{ZC} 1V680XV	900
	100	8.0	10.2	10.5	F	1600	1900	27	0.12	EEH ^{ZC} 1V101P	EEH ^{ZC} 1V101V	500
	150	8.0	10.2	10.5	F	1600	1900	27	0.12	EEH ^{ZC} 1V151P	EEH ^{ZC} 1V151V	500
50	220	10.0	10.2	10.5	G	2000	2800	20	0.12	EEH ^{ZC} 1V221P	EEH ^{ZC} 1V221V	500
	270	10.0	10.2	10.5	G	2000	2800	20	0.12	EEH ^{ZC} 1V271P	EEH ^{ZC} 1V271V	500
	10	5.0	5.8	–	C	500	–	120	0.10	EEH ^{ZC} 1H100R	–	1000
	22	6.3	5.8	6.1	D	750	–	80	0.10	EEH ^{ZC} 1H220P	EEH ^{ZC} 1H220V	1000
	33	6.3	7.7	8.0	D8	1100	–	40	0.10	EEH ^{ZC} 1H330XP	EEH ^{ZC} 1H330XV	900
	47	8.0	10.2	10.5	F	1250	–	30	0.10	EEH ^{ZC} 1H470P	EEH ^{ZC} 1H470V	500
	68	8.0	10.2	10.5	F	1250	–	30	0.10	EEH ^{ZC} 1H680P	EEH ^{ZC} 1H680V	500
	100	10.0	10.2	10.5	G	1600	–	28	0.10	EEH ^{ZC} 1H101P	EEH ^{ZC} 1H101V	500
63	120	10.0	10.2	10.5	G	1600	–	28	0.10	EEH ^{ZC} 1H121P	EEH ^{ZC} 1H121V	500
	10	6.3	5.8	6.1	D	700	–	120	0.08	EEH ^{ZC} 1J100P	EEH ^{ZC} 1J100V	1000
	22	6.3	7.7	8.0	D8	900	–	80	0.08	EEH ^{ZC} 1J220XP	EEH ^{ZC} 1J220XV	900
	33	8.0	10.2	10.5	F	1100	–	40	0.08	EEH ^{ZC} 1J330P	EEH ^{ZC} 1J330V	500
	47	8.0	10.2	10.5	F	1100	–	40	0.08	EEH ^{ZC} 1J470P	EEH ^{ZC} 1J470V	500
	56	10.0	10.2	10.5	G	1400	–	30	0.08	EEH ^{ZC} 1J560P	EEH ^{ZC} 1J560V	500
	68	10.0	10.2	10.5	G	1400	–	30	0.08	EEH ^{ZC} 1J680P	EEH ^{ZC} 1J680V	500
	82	10.0	10.2	10.5	G	1400	–	30	0.08	EEH ^{ZC} 1J820P	EEH ^{ZC} 1J820V	500
80	22	8.0	10.2	10.5	F	1050	–	45	0.08	EEH ^{ZC} 1K220P	EEH ^{ZC} 1K220V	500
	33	10.0	10.2	10.5	G	1360	–	36	0.08	EEH ^{ZC} 1K330P	EEH ^{ZC} 1K330V	500
	47	10.0	10.2	10.5	G	1360	–	36	0.08	EEH ^{ZC} 1K470P	EEH ^{ZC} 1K470V	500

*1: Ripple current (100 kHz / +125 °C) *2: ESR (100 kHz / +20 °C) *3: tan δ (120 Hz / +20 °C)

- ◆ Please refer to the page of "Reflow profile" and "The taping dimensions".
- ◆ The dimensions of the vibration-proof products, please refer to the page of the mounting specification.

Frequency correction factor for ripple current

Rated capacitance (C)	Frequency (f)	100 Hz ≤ f < 200 Hz	200 Hz ≤ f < 300 Hz	300 Hz ≤ f < 500 Hz	500 Hz ≤ f < 1 kHz
C < 47 μF	Correction factor	0.10	0.10	0.15	0.20
47 μF ≤ C < 150 μF		0.15	0.20	0.25	0.30
150 μF ≤ C		0.15	0.25	0.25	0.30
Rated capacitance (C)	Frequency (f)	1 kHz ≤ f < 2 kHz	2 kHz ≤ f < 3 kHz	3 kHz ≤ f < 5 kHz	5 kHz ≤ f < 10 kHz
C < 47 μF	Correction factor	0.30	0.40	0.45	0.50
47 μF ≤ C < 150 μF		0.40	0.45	0.55	0.60
150 μF ≤ C		0.45	0.50	0.60	0.65
Rated capacitance (C)	Frequency (f)	10 kHz ≤ f < 15 kHz	15 kHz ≤ f < 20 kHz	20 kHz ≤ f < 30 kHz	30 kHz ≤ f < 40 kHz
C < 47 μF	Correction factor	0.60	0.65	0.70	0.75
47 μF ≤ C < 150 μF		0.70	0.75	0.80	0.80
150 μF ≤ C		0.75	0.80	0.85	0.85
Rated capacitance (C)	Frequency (f)	40 kHz ≤ f < 50 kHz	50 kHz ≤ f < 100 kHz	100 kHz ≤ f < 500 kHz	500 kHz ≤ f
C < 47 μF	Correction factor	0.80	0.85	1.00	1.05
47 μF ≤ C < 150 μF		0.85	0.90	1.00	1.00
150 μF ≤ C		0.85	0.90	1.00	1.00

After endurance ESR (100 kHz, -40°C)

Size code	C	D	D8	F	G
ESR (Ω)	2	1.4	0.8	0.4	0.3

Conductive Polymer Hybrid Aluminum Electrolytic Capacitors
Surface Mount Type

ZK series

High temperature lead-free reflow

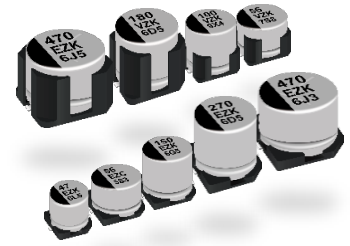

Features

- High capacitance and High ripple current compared with ZC series
- Endurance : 4000 h at 125 °C (High temperature / Long life)
- Low ESR
- Characteristics dependencies in frequency and low temperature are as small as polymer type
- Vibration-proof product is available upon request (ø6.3, ø8, ø10)
- AEC-Q200 compliant
- RoHS compliant

Specifications

Size code	C	D	D8	F	G
Category temp. range	-55 °C to +125 °C				
Rated voltage range	25 V to 35 V				
Nominal capacitance range	33 µF to 47 µF	56 µF to 82 µF	100 µF to 150 µF	180 µF to 270 µF	330 µF to 470 µF
Capacitance tolerance	±20 % (120 Hz / +20 °C)				
Leakage current	I ≤ 0.01 CV (µA), 2 minutes after reaching rated voltage, 20 °C *CV = (Capacitance in µF) x (Rated voltage in V)				
Dissipation factor (tan δ)	Please see the attached characteristics list				
Surge voltage (V)	Rated voltage × 1.25 (15 °C to 35 °C)				
Endurance	+125 °C ± 2 °C, 4000 h, apply the rated ripple current without exceeding the rated voltage.				
	Capacitance change	Within ±30% of the initial value			
	Dissipation factor (tan δ)	≤ 200 % of the initial limit			
	ESR	≤ 200 % of the initial limit			
	Leakage current	Within the initial limit			
ESR after endurance (Ω / 100 kHz)(-40 °C)	Size code				
	C	D	D8	F	G
	2.0	1.4	0.8	0.4	0.3
Shelf life	After storage for 1000 hours at +125 °C ± 2 °C with no voltage applied and then being stabilized at +20 °C, capacitors shall meet the limits specified in endurance. (Capacitors are left at room temperature and humidity for 2 hours after the test. Then, apply the rated voltage for 30min with a series protection resistance of 1000 Ω ± 10 Ω. Measure electrical characteristics after discharging the capacitor.)				
Damp heat (Load)	+85 °C ± 2 °C, 85 % to 90 %RH, 2000 h, rated voltage applied				
	Capacitance change	Within ±30% of the initial value			
	Dissipation factor (tan δ)	≤ 200 % of the initial limit			
	ESR	≤ 200 % of the initial limit			
	Leakage current	Within the initial limit			
Resistance to soldering heat	After reflow soldering and then being stabilized at +20 °C, capacitors shall meet the following limits.				
	Capacitance change	Within ±10% of the initial value			
	Dissipation factor (tan δ)	Within the initial limit			
	Leakage current	Within the initial limit			

Marking

Example : 25 V 47 µF
Marking color : BLACK

Negative polarity marking (-)

Capacitance (µF)

Series identification

Rated voltage code

Lot number

R. voltage code	Unit : V
E	25
V	35

Dimensions (not to scale)

[Standard]

Pressure relief (ø10 ±) () Reference size

Size code	øD	L	A, B	H _{max.}	I	W	P	K
C	5.0	5.8±0.3	5.3	6.5	2.2	0.65±0.1	1.5	0.35 ^{+0.15} _{-0.20}
D	6.3	5.8±0.3	6.6	7.8	2.6	0.65±0.1	1.8	0.35 ^{+0.15} _{-0.20}
D8	6.3	7.7±0.3	6.6	7.8	2.6	0.65±0.1	1.8	0.35 ^{+0.15} _{-0.20}
F	8.0	10.2±0.3	8.3	10	3.4	0.90±0.2	3.1	0.70±0.2
G	10.0	10.2±0.3	10.3	12.0	3.5	0.90±0.2	4.6	0.70±0.2

Unit : mm

[Vibration-proof product]

< Size code : D, D8 >

Supportive terminals () Reference size

< Size code : F, G >

Pressure relief (ø10 ±) Supportive terminals () Reference size

Size code	øD	L	A, B	H _{max.}	F	I	W	P	K	R	S	T
D	6.3	6.1±0.3	6.6	7.8	0 to +0.15	2.4	0.65±0.1	2.2	0.35 ^{+0.15} _{-0.20}	1.1±0.2	3.3	1.05±0.2
D8	6.3	8.0±0.3	6.6	7.8	0 to +0.15	2.4	0.65±0.1	2.2	0.35 ^{+0.15} _{-0.20}	1.1±0.2	3.3	1.05±0.2
F	8.0	10.5±0.3	8.3	10.0	0 to +0.15	3.4	1.2±0.2	3.1	0.70±0.2	0.70±0.2	5.3	1.3±0.2
G	10.0	10.5±0.3	10.3	12.0	0 to +0.15	3.5	1.2±0.2	4.6	0.70±0.2	0.70±0.2	6.9	1.3±0.2

Unit : mm

Explanation of part numbers

◆ Part number system e.g.: EEHZK1E470R

EEH	ZK		1E		471		X	R				
Product classification	Series	Code	Rated voltage (V)	Code *	Capacitance (μF)	Code	Capacitance (μF)	Code	D8 size** øDxL(mm)	Code	Tape width (mm)	Code
	ZK	ZK	25	1E	33	330	150	151	6.3 x 7.7	X	16 to 24	P
			35	1V	47	470	180	181				
					56	560	270	271				
					68	680	330	331				
					82	820	470	471				
					100	101						

Replace for the following configuration	
Configuration	Code
Vibration proof	V

*: If the total figures number of the part number exceeds 12 figures, "1" is omitted.
 **: Only D8 is marked with X

Characteristics list

Endurance : 125 °C 4000 h

Rated voltage (V)	Capacitance (±20 %) (μF)	Case size (mm)			Size code	Specification			Part number		Min. packaging q'ty (pcs)
		øD	L			Ripple current*1 (mA rms)	ESR*2 (mΩ)	tan δ*3	Standard product	Vibration-proof product	Taping
			Standard	Vibration-proof							
25	47	5.0	5.8	—	C	850	80	0.14	EEHZK1E470R	—	1000
	68	6.3	5.8	6.1	D	1300	50	0.14	EEHZK1E680P	EEHZK1E680V	1000
	82	6.3	5.8	6.1	D	1300	50	0.14	EEHZK1E820P	EEHZK1E820V	1000
	150	6.3	7.7	8.0	D8	1800	30	0.14	EEHZK1E151XP	EEHZK1E151XV	900
	270	8.0	10.2	10.5	F	2000	27	0.14	EEHZK1E271P	EEHZK1E271V	500
35	470	10.0	10.2	10.5	G	2800	20	0.14	EEHZK1E471P	EEHZK1E471V	500
	33	5.0	5.8	—	C	750	100	0.12	EEHZK1V330R	—	1000
	56	6.3	5.8	6.1	D	1200	60	0.12	EEHZK1V560P	EEHZK1V560V	1000
	100	6.3	7.7	8.0	D8	1700	35	0.12	EEHZK1V101XP	EEHZK1V101XV	900
	180	8.0	10.2	10.5	F	2000	27	0.12	EEHZK1V181P	EEHZK1V181V	500
	330	10.0	10.2	10.5	G	2800	20	0.12	EEHZK1V331P	EEHZK1V331V	500

*1: Ripple current (100 kHz / +125 °C)

*2: ESR (100 kHz / +20 °C)

*3: tan δ (120 Hz / +20 °C)

◆ Please refer to the page of "Reflow profile" and "The taping dimensions".

◆ The dimensions of the vibration-proof products, please refer to the page of the mounting specification.

Frequency correction factor for ripple current

Rated capacitance (C)	Frequency (f)	100 Hz ≤ f < 200 Hz	200 Hz ≤ f < 300 Hz	300 Hz ≤ f < 500 Hz	500 Hz ≤ f < 1 kHz
C < 47 μF	Correction factor	0.15	0.20	0.25	0.35
47 μF ≤ C < 100 μF		0.15	0.25	0.30	0.40
100 μF ≤ C		0.15	0.25	0.30	0.40

Rated capacitance (C)	Frequency (f)	1 kHz ≤ f < 2 kHz	2 kHz ≤ f < 3 kHz	3 kHz ≤ f < 5 kHz	5 kHz ≤ f < 10 kHz
C < 47 μF	Correction factor	0.45	0.55	0.60	0.65
47 μF ≤ C < 100 μF		0.50	0.60	0.65	0.70
100 μF ≤ C		0.50	0.60	0.65	0.70

Rated capacitance (C)	Frequency (f)	10 kHz ≤ f < 15 kHz	15 kHz ≤ f < 20 kHz	20 kHz ≤ f < 30 kHz	30 kHz ≤ f < 40 kHz
C < 47 μF	Correction factor	0.70	0.75	0.75	0.75
47 μF ≤ C < 100 μF		0.75	0.75	0.80	0.80
100 μF ≤ C		0.75	0.80	0.85	0.85

Rated capacitance (C)	Frequency (f)	40 kHz ≤ f < 50 kHz	50 kHz ≤ f < 100 kHz	100 kHz ≤ f < 500 kHz	500 kHz ≤ f
C < 47 μF	Correction factor	0.80	0.85	1.00	1.05
47 μF ≤ C < 100 μF		0.85	0.90	1.00	1.00
100 μF ≤ C		0.85	0.90	1.00	1.00

Conductive Polymer Hybrid Aluminum Electrolytic Capacitors
Surface Mount Type

ZKU series **High temperature lead-free reflow**

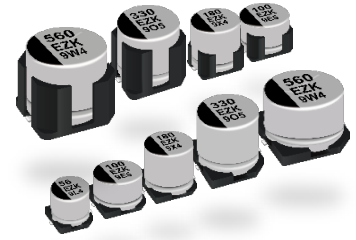

Features

- Endurance : 4000 h at 125 °C (High temperature / Long life)
- Large capacitance compared with ZK series
- Low ESR
- Characteristics dependencies in frequency and low temperature are as small as polymer type
- Vibration-proof product is available upon request. (ø6.3, ø8, ø10)
- AEC-Q200 compliant
- RoHS compliant

Specifications

Size code	C	D	D8	F	G
Category temp. range	-55 °C to +125 °C				
Rated voltage range	25 V to 35 V				
Nominal capacitance range	39 µF to 56 µF	68 µF to 100 µF	120 µF to 180 µF	220 µF to 330 µF	390 µF to 560 µF
Capacitance tolerance	±20 % (120 Hz / +20 °C)				
Leakage current	I ≤ 0.01 CV (µA), 2 minutes after reaching rated voltage, 20 °C *CV = (Capacitance in µF) x (Rated voltage in V)				
Dissipation factor (tan δ)	Please see the attached characteristics list				
Surge voltage (V)	Rated voltage × 1.25 (15 °C to 35 °C)				
Endurance	+125 °C ± 2 °C 4000 h, apply the rated ripple current without exceeding the rated voltage.				
	Capacitance change	Within ±30% of the initial value			
	Dissipation factor (tan δ)	≤ 200 % of the initial limit			
	ESR	≤ 200 % of the initial limit			
	Leakage current	Within the initial limit			
ESR after endurance (Ω / 100 kHz)(-40 °C)	Size code				
	C	D	D8	F	G
	2.0	1.4	0.8	0.4	0.3
Shelf life	After storage for 1000 hours at +125 °C ± 2 °C with no voltage applied and then being stabilized at +20 °C, capacitors shall meet the limits specified in endurance. (Capacitors are left at room temperature and humidity for 2 hours after the test. Then, apply the rated voltage for 30min with a series protection resistance of 1000 Ω ± 10 Ω. Measure electrical characteristics after discharging the capacitor.)				
Damp heat (Load)	+85 °C ± 2 °C, 85 % to 90 %RH, 2000 h, rated voltage applied				
	Capacitance change	Within ±30% of the initial value			
	Dissipation factor (tan δ)	≤ 200 % of the initial limit			
	ESR	≤ 200 % of the initial limit			
	Leakage current	Within the initial limit			

Marking

Example : 25 V 56 µF
Marking color : BLACK

Negative polarity marking (-)
Capacitance (µF)
Series identification
Rated voltage code
Lot number

R. voltage code	Unit : V
E	25
V	35

Dimensions (not to scale)

[Standard]

Size code	øD	L	A, B	H _{max.}	I	W	P	K
C	5.0	5.8±0.3	5.3	6.5	2.2	0.65±0.1	1.5	0.35 ^{+0.15} _{-0.20}
D	6.3	5.8±0.3	6.6	7.8	2.6	0.65±0.1	1.8	0.35 ^{+0.15} _{-0.20}
D8	6.3	7.7±0.3	6.6	7.8	2.6	0.65±0.1	1.8	0.35 ^{+0.15} _{-0.20}
F	8.0	10.2±0.3	8.3	10	3.4	0.90±0.2	3.1	0.70±0.2
G	10.0	10.2±0.3	10.3	12.0	3.5	0.90±0.2	4.6	0.70±0.2

[Vibration-proof product]
< Size code : D, D8 >

< Size code : F, G >

Size code	øD	L	A, B	H _{max.}	F	I	W	P	K	R	S	T
D	6.3	6.1±0.3	6.6	7.8	0 to +0.15	2.4	0.65±0.1	2.2	0.35 ^{+0.15} _{-0.20}	1.1±0.2	3.3	1.05±0.2
D8	6.3	8.0±0.3	6.6	7.8	0 to +0.15	2.4	0.65±0.1	2.2	0.35 ^{+0.15} _{-0.20}	1.1±0.2	3.3	1.05±0.2
F	8.0	10.5±0.3	8.3	10.0	0 to +0.15	3.4	1.2±0.2	3.1	0.70±0.2	0.70±0.2	5.3	1.3±0.2
G	10.0	10.5±0.3	10.3	12.0	0 to +0.15	3.5	1.2±0.2	4.6	0.70±0.2	0.70±0.2	6.9	1.3±0.2

Explanation of part numbers

◆ Part number system e.g.: EEHZKE181XUP

EEH	ZK		E		181		X		U		P	
Product classification	Series	Code	Rated voltage (V)	Code *	Capacitance (μF)	Code	D8 size ** øDxL(mm)	Code	Dia øD	Code	Tape width (mm)	Code
	ZKU	ZK	25	1E	39	390	6.3 x 7.7	X	Miniaturized product	U	12	R
			35	1V	56	560					16 to 24	P
					68	680						
					100	101						
					120	121						
					180	181						
					220	221						
					330	331						
					390	391						
					560	561						

Replace for the following configuration

Configuration	Code
Vibration proof	V

*: If the total figures number of the part number exceeds 12 figures, "1" is omitted.
 **: Only D8 is marked with X

Characteristics list

Endurance : 125 °C 4000 h

Rated voltage (V)	Capacitance (±20 %) (μF)	Case size (mm)			Size code	Specification			Part number		Min. packaging q'ty (pcs)
		øD	L			Ripple current *1 (mA rms)	ESR *2 (mΩ)	tan δ *3	Standard product	Vibration-proof product	
			Standard	Vibration-proof							
25	56	5	5.8	-	C	850	80	0.14	EEHZK1E560UR	-	1000
	100	6.3	5.8	6.1	D	1300	50	0.14	EEHZK1E101UP	EEHZK1E101UV	1000
	180	6.3	7.7	8.0	D8	1800	30	0.14	EEHZKE181XUP	EEHZKE181XUV	900
	330	8	10.2	10.5	F	2000	27	0.14	EEHZK1E331UP	EEHZK1E331UV	500
	560	10	10.2	10.5	G	2800	20	0.14	EEHZK1E561UP	EEHZK1E561UV	500
35	39	5	5.8	-	C	750	100	0.12	EEHZK1V390UR	-	1000
	68	6.3	5.8	6.1	D	1200	60	0.12	EEHZK1V680UP	EEHZK1V680UV	1000
	120	6.3	7.7	8.0	D8	1700	35	0.12	EEHZKV121XUP	EEHZKV121XUV	900
	220	8	10.2	10.5	F	2000	27	0.12	EEHZK1V221UP	EEHZK1V221UV	500
	390	10	10.2	10.5	G	2800	20	0.12	EEHZK1V391UP	EEHZK1V391UV	500

*1: Ripple current (100 kHz / +125 °C)

*2: ESR (100 kHz / +20 °C)

*3: tan δ (120 Hz / +20 °C)

- ◆ Please refer to the page of "Reflow profile" and "The taping dimensions".
- ◆ The dimensions of the vibration-proof products, please refer to the page of the mounting specification.

Frequency correction factor for ripple current

Rated capacitance (C)	Frequency(f)	100 Hz ≤ f < 200 Hz	200 Hz ≤ f < 300 Hz	300 Hz ≤ f < 500 Hz	500 Hz ≤ f < 1 kHz
C < 47 μF	Correction factor	0.15	0.20	0.25	0.35
47 μF ≤ C < 100 μF		0.15	0.25	0.30	0.40
100 μF ≤ C		0.15	0.25	0.30	0.40

Rated capacitance (C)	Frequency(f)	1 kHz ≤ f < 2 kHz	2 kHz ≤ f < 3 kHz	3 kHz ≤ f < 5 kHz	5 kHz ≤ f < 10 kHz
C < 47 μF	Correction factor	0.45	0.55	0.60	0.65
47 μF ≤ C < 100 μF		0.50	0.60	0.65	0.70
100 μF ≤ C		0.50	0.60	0.65	0.70

Rated capacitance (C)	Frequency(f)	10 kHz ≤ f < 15 kHz	15 kHz ≤ f < 20 kHz	20 kHz ≤ f < 30 kHz	30 kHz ≤ f < 40 kHz
C < 47 μF	Correction factor	0.70	0.75	0.75	0.75
47 μF ≤ C < 100 μF		0.75	0.75	0.80	0.80
100 μF ≤ C		0.75	0.80	0.85	0.85

Rated capacitance (C)	Frequency(f)	40 kHz ≤ f < 50 kHz	50 kHz ≤ f < 100 kHz	100 kHz ≤ f < 500 kHz	500 kHz ≤ f
C < 47 μF	Correction factor	0.80	0.85	1.00	1.05
47 μF ≤ C < 100 μF		0.85	0.90	1.00	1.00
100 μF ≤ C		0.85	0.90	1.00	1.00

Conductive Polymer Hybrid Aluminum Electrolytic Capacitors
Surface Mount Type

ZL series

High temperature lead-free reflow

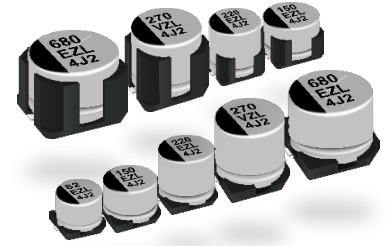

Features

- Endurance : 4000 h at 125 °C / 135 °C
- Higher capacitance (max 150 % of ZKU series)
- AEC-Q200 compliant
- Smaller than ZC series with the same capacitance
- Low ESR (max 40 %, lower ESR than ZC or ZKU series)
- RoHS compliant

Specifications

Size code	C	D	D8	F	G
Category temp. range	-55 °C to +135 °C				
Rated voltage range	25 V to 35 V				
Nominal capacitance range	47 μF to 82 μF	82 μF to 150 μF	150 μF to 220 μF	270 μF to 470 μF	470 μF to 680 μF
Capacitance tolerance	±20 % (120 Hz / +20 °C)				
Leakage current	I ≤ 0.01 CV (μA), 2 minutes after reaching rated voltage, 20 °C *CV = (Capacitance in μF) x (Rated voltage in V)				
Dissipation factor (tan δ)	Please see the attached characteristics list				
Surge voltage (V)	Rated voltage × 1.25 (15 °C to 35 °C)				
Endurance 1	+125 °C ± 2 °C 4000 h, apply the rated ripple current without exceeding the rated voltage.				
	Capacitance change	Within ±30% of the initial value			
	Dissipation factor (tan δ)	≤ 200 % of the initial limit			
	ESR	≤ 200 % of the initial limit			
	Leakage current	Within the initial limit			
Endurance 2	+135 °C ± 2 °C 2000 h (C,D,D8 size) or 4000 h (F,G size), apply the rated ripple current without exceeding the rated voltage.				
	Capacitance change	Within ±30% of the initial value			
	Dissipation factor (tan δ)	≤ 200 % of the initial limit			
	ESR	≤ 200 % of the initial limit			
	Leakage current	Within the initial limit			
Shelf life	After storage for 1000 hours at +135 °C ± 2 °C with no voltage applied and then being stabilized at +20 °C, capacitors shall meet the limits specified in endurance. (Capacitors are left at room temperature and humidity for 2 hours after the test. Then, apply the rated voltage for 30min with a series protection resistance of 1000 Ω ± 10 Ω. Measure electrical characteristics after discharging the capacitor.)				
	+85 °C ± 2 °C, 85 % to 90 %RH, 2000 h, rated voltage applied				
	Capacitance change	Within ±30% of the initial value			
	Dissipation factor (tan δ)	≤ 200 % of the initial limit			
	ESR	≤ 200 % of the initial limit			
Damp heat (Load)	After reflow soldering and then being stabilized at +20 °C, capacitors shall meet the following limits.				
	Capacitance change	Within ±10 % of the initial value			
	Dissipation factor (tan δ)	Within the initial limit			
	Leakage current	Within the initial limit			
	Resistance to soldering heat	Within the initial limit			

Marking

Example : 25 V 470 μF
Marking color : BLACK

Negative polarity marking (-)
Capacitance (μF)
Series identification
Rated voltage code
Lot number

R. voltage code	Unit : V
E	25
V	35

Dimensions (not to scale)

[Standard]

Size code	øD	L	A, B	H _{max}	I	W	P	K
C	5.0	5.8±0.3	5.3	6.5	2.2	0.65±0.1	1.5	0.35 ^{+0.15} _{-0.20}
D	6.3	5.8±0.3	6.6	7.8	2.6	0.65±0.1	1.8	0.35 ^{+0.15} _{-0.20}
D8	6.3	7.7±0.3	6.6	7.8	2.6	0.65±0.1	1.8	0.35 ^{+0.15} _{-0.20}
F	8.0	10.2±0.3	8.3	10	3.4	0.90±0.2	3.1	0.70±0.2
G	10.0	10.2±0.3	10.3	12.0	3.5	0.90±0.2	4.6	0.70±0.2

[Vibration-proof product]
< Size code : D, D8 >

Size code	øD	L	A, B	H _{max}	F	I	W	P	K	R	S	T
D	6.3	6.1±0.3	6.6	7.8	0 to +0.15	2.4	0.65±0.1	2.2	0.35 ^{+0.15} _{-0.20}	1.1±0.2	3.3	1.05±0.2
D8	6.3	8.0±0.3	6.6	7.8	0 to +0.15	2.4	0.65±0.1	2.2	0.35 ^{+0.15} _{-0.20}	1.1±0.2	3.3	1.05±0.2
F	8.0	10.5±0.3	8.3	10.0	0 to +0.15	3.4	1.2±0.2	3.1	0.70±0.2	0.70±0.2	5.3	1.3±0.2
G	10.0	10.5±0.3	10.3	12.0	0 to +0.15	3.5	1.2±0.2	4.6	0.70±0.2	0.70±0.2	6.9	1.3±0.2

< Size code : F, G >

Explanation of part numbers

◆ Part number system

e.g.: EEH^{ZL}1E221XP

Product classification	ZL		1E		221		X		P			
	Series	Code	Rated voltage (V)	Code *	Capacitance (μF)	Code	Capacitance (μF)	Code	D8 size** øDxL(mm)	Code	Tape width (mm)	Code
	ZL	ZL	25	1E	47	470	270	271	6.3 x 7.7	X	12	R
			35	1V	82	820	470	471			16 to 24	P
					150	151	680	681				
					220	221						

Replace for the following configuration	
Configuration	Code
Vibration proof	V

*: If the total figures number of the part number exceeds 12 figures, "1" is omitted.
 **: Only D8 is marked with X

Characteristics list

Endurance 1 : 125 °C 4000 h

Endurance 2 : 135 °C 2000 h (C, D, D8 size) / 4000 h (F, G size)

Rated voltage (V)	Capacitance (±20 %) (μF)	Case size (mm)			Size code	Specification				Part number		Min. packaging q'ty (pcs)
		øD	L			Ripple current ^{*1} (mA rms)	ESR ^{*2} (mΩ)	tan δ ^{*3}	Standard product	Vibration-proof product	Taping	
			Standard	Vibration-proof								Endurance 1 (+125°C)
25	82	5.0	5.8	-	C	1000	600	58	0.14	EEH ^{ZL} 1E820R	-	1000
	150	6.3	5.8	6.1	D	1500	800	38	0.14	EEH ^{ZL} 1E151P	EEH ^{ZL} 1E151V	1000
	220	6.3	7.7	8.0	D8	2000	1000	24	0.14	EEH ^{ZL} 1E221XP	EEH ^{ZL} 1E221XV	900
	470	8.0	10.2	10.5	F	3000	2000	18	0.14	EEH ^{ZL} 1E471P	EEH ^{ZL} 1E471V	500
	680	10.0	10.2	10.5	G	3400	2300	14	0.14	EEH ^{ZL} 1E681P	EEH ^{ZL} 1E681V	500
35	47	5.0	5.8	-	C	900	550	60	0.12	EEH ^{ZL} 1V470R	-	1000
	82	6.3	5.8	6.1	D	1400	700	40	0.12	EEH ^{ZL} 1V820P	EEH ^{ZL} 1V820V	1000
	150	6.3	7.7	8.0	D8	1900	900	26	0.12	EEH ^{ZL} 1V151XP	EEH ^{ZL} 1V151XV	900
	270	8.0	10.2	10.5	F	2900	1900	20	0.12	EEH ^{ZL} 1V271P	EEH ^{ZL} 1V271V	500
	470	10.0	10.2	10.5	G	3300	2200	16	0.12	EEH ^{ZL} 1V471P	EEH ^{ZL} 1V471V	500

*1: Ripple current (100 kHz / +125 °C or +135 °C)

*2: ESR (100 kHz / +20 °C)

*3: tan δ (120 Hz / +20 °C)

◆ Please refer to the page of "Reflow profile" and "The taping dimensions".

◆ The dimensions of the vibration-proof products, please refer to the page of the mounting specification.

Frequency correction factor for ripple current

Rated capacitance (C)	Frequency(f)	100 Hz ≤ f < 200 Hz	200 Hz ≤ f < 300 Hz	300 Hz ≤ f < 500 Hz	500 Hz ≤ f < 1 kHz
47 μF ≤ C < 150 μF	Correction	0.15	0.20	0.25	0.30
	factor				
150 μF ≤ C		0.15	0.25	0.25	0.30

Rated capacitance (C)	Frequency(f)	1 kHz ≤ f < 2 kHz	2 kHz ≤ f < 3 kHz	3 kHz ≤ f < 5 kHz	5 kHz ≤ f < 10 kHz
47 μF ≤ C < 150 μF	Correction	0.40	0.45	0.55	0.60
	factor				
150 μF ≤ C		0.45	0.50	0.60	0.65

Rated capacitance (C)	Frequency(f)	10 kHz ≤ f < 15 kHz	15 kHz ≤ f < 20 kHz	20 kHz ≤ f < 30 kHz	30 kHz ≤ f < 40 kHz
47 μF ≤ C < 150 μF	Correction	0.70	0.75	0.80	0.80
	factor				
150 μF ≤ C		0.75	0.80	0.85	0.85

Rated capacitance (C)	Frequency(f)	40 kHz ≤ f < 50 kHz	50 kHz ≤ f < 100 kHz	100 kHz ≤ f < 500 kHz	500 kHz ≤ 1000 kHz
47 μF ≤ C < 150 μF	Correction	0.85	0.90	1.00	1.00
	factor				
150 μF ≤ C		0.85	0.90	1.00	1.00

Conductive Polymer Hybrid Aluminum Electrolytic Capacitors

Surface Mount Type

ZT series

High temperature lead-free reflow

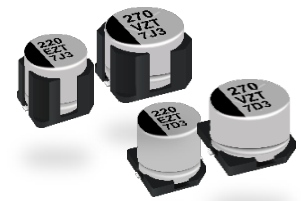

Features

- Endurance: 4000 h at 135 °C / 125 °C
- Higher ripple current (75 % to 118 % higher than ZC series)
- Vibration-proof product is available upon request.
- AEC-Q200 compliant
- RoHS compliant

Specifications

Size code	F	G	
Category temp. range	-55 °C to +135 °C		
Rated voltage range	25 V to 63 V		
Nominal capacitance range	33 μF to 220 μF	56 μF to 330 μF	
Capacitance tolerance	±20 % (120 Hz / +20 °C)		
Leakage current	$I \leq 0.01 CV (\mu A)$, 2 minutes after reaching rated voltage, 20 °C *CV = (Capacitance in μF) x (Rated voltage in V)		
Dissipation factor (tan δ)	Please see the attached characteristics list		
Surge voltage (V)	Rated voltage × 1.25 (15 °C to 35 °C)		
Endurance 1	+125 °C ± 2 °C, 4000 h, apply the rated ripple current without exceeding the rated voltage		
	Capacitance change	Within ±30% of the initial value	
	Dissipation factor (tan δ)	≤ 200 % of the initial limit	
	E.S.R.	≤ 200 % of the initial limit	
	Leakage current	Within the initial limit	
ESR after endurance (Ω / 100 kHz)(-40 °C)	Size code		
	F	G	
		0.4	0.3
Endurance 2	+135 °C ± 2 °C, 4000 h, apply the rated ripple current without exceeding the rated voltage		
	Capacitance change	Within ±30% of the initial value	
	Dissipation factor (tan δ)	≤ 200 % of the initial limit	
	E.S.R.	≤ 200 % of the initial limit	
	Leakage current	Within the initial limit	
ESR after endurance (Ω / 100 kHz)(-40 °C)	Size code		
	F	G	
		0.4	0.3
Shelf life	After storage for 1000 hours at +135 °C ± 2 °C with no voltage applied and then being stabilized at +20 °C, capacitors shall meet the limits specified in endurance. (Capacitors are left at room temperature and humidity for 2 hours after the test. Then, apply the rated voltage for 30min with a series protection resistance of 1000 Ω ± 10 Ω. Measure electrical characteristics after discharging the capacitor.)		
Damp heat (Load)	85 °C ± 2 °C, 85 % to 90 %RH, 2000 h, rated voltage applied		
	Capacitance change	Within ±30% of the initial value	
	Dissipation factor (tan δ)	≤ 200 % of the initial limit	
	E.S.R.	≤ 200 % of the initial limit	
Resistance to soldering heat	After reflow soldering and then being stabilized at +20 °C, capacitors shall meet the following limits.		
	Capacitance change	Within ±10% of the initial value	
	Dissipation factor (tan δ)	Within the initial limit	
Leakage current	Within the initial limit		

Marking

Example : 25 V 220 μF
Marking color : BLACK

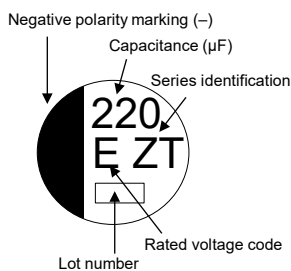

R. voltage code	Unit : V
E	25
V	35
H	50
J	63

Dimensions (not to scale)

[Standard]

[Vibration-proof product]

Size code	øD	L	A, B	H _{max}	I	W	P	K
F	8.0	10.2±0.3	8.3	10.0	3.4	0.90±0.2	3.1	0.70±0.2
G	10.0	10.2±0.3	10.3	12.0	3.5	0.90±0.2	4.6	0.70±0.2

Size code	øD	L	A, B	H _{max}	F	I	W	P	K	R	S	T
F	8.0	10.5±0.3	8.3	10.0	0 to +0.15	3.4	1.2±0.2	3.1	0.70±0.2	0.70±0.2	5.3	1.3±0.2
G	10.0	10.5±0.3	10.3	12.0	0 to +0.15	3.5	1.2±0.2	4.6	0.70±0.2	0.70±0.2	6.9	1.3±0.2

Explanation of part numbers

◆ Part number system

e.g.: EEH^{ZT}1E221P

EEH	ZT		1E		221		P			
Product classification	Series	Code	Rated voltage (V)	Code*	Capacitance (μF)	Code	Capacitance (μF)	Code	Tape width (mm)	Code
	ZT	ZT	25	1E	33	330	120	121	16 to 24	P
			35	1V	47	470	150	151		
			50	1H	56	560	220	221		
			63	1J	68	680	270	271		
					82	820	330	331		
					100	101				

Replace for the following configuration	
Configuration	Code
Vibration proof	V

*: If the total figures number of the part number exceeds 12 figures, "1" is omitted.

Characteristics list

Endurance 1 : 125 °C 4000 h

Endurance 2 : 135 °C 4000 h

Rated voltage (V)	Capacitance (±20 %) (μF)	Case size (mm)			Size code	Specification				Part number		Min. packaging q'ty (pcs)
		øD	L			Ripple current ^{*1} (mA rms)	ESR ^{*2} (mΩ)	tan δ ^{*3}	Standard product	Vibration-proof product		
			Standard	Vibration-proof							Endurance 1 125 °C	Endurance 2 135 °C
25	220	8.0	10.2	10.5	F	2900	1800	22	0.14	EEH ^{ZT} 1E221P	EEH ^{ZT} 1E221V	500
	330	10.0	10.2	10.5	G	3500	2200	16	0.14	EEH ^{ZT} 1E331P	EEH ^{ZT} 1E331V	500
35	150	8.0	10.2	10.5	F	2900	1800	22	0.12	EEH ^{ZT} 1V151P	EEH ^{ZT} 1V151V	500
	270	10.0	10.2	10.5	G	3500	2200	16	0.12	EEH ^{ZT} 1V271P	EEH ^{ZT} 1V271V	500
50	68	8.0	10.2	10.5	F	2700	1700	25	0.10	EEH ^{ZT} 1H680P	EEH ^{ZT} 1H680V	500
	100	10.0	10.2	10.5	G	2900	1800	23	0.10	EEH ^{ZT} 1H101P	EEH ^{ZT} 1H101V	500
	120	10.0	10.2	10.5	G	2900	1800	23	0.10	EEH ^{ZT} 1H121P	EEH ^{ZT} 1H121V	500
63	33	8.0	10.2	10.5	F	2400	1500	32	0.08	EEH ^{ZT} 1J330P	EEH ^{ZT} 1J330V	500
	47	8.0	10.2	10.5	F	2400	1500	32	0.08	EEH ^{ZT} 1J470P	EEH ^{ZT} 1J470V	500
	56	10.0	10.2	10.5	G	2800	1700	25	0.08	EEH ^{ZT} 1J560P	EEH ^{ZT} 1J560V	500
	68	10.0	10.2	10.5	G	2800	1700	25	0.08	EEH ^{ZT} 1J680P	EEH ^{ZT} 1J680V	500
	82	10.0	10.2	10.5	G	2800	1700	25	0.08	EEH ^{ZT} 1J820P	EEH ^{ZT} 1J820V	500

*1: Ripple current (100 kHz / +125 °C or 135 °C)

*2: ESR (100 kHz / +20 °C)

*3: tan δ (120 Hz / +20 °C)

- ◆ Please refer to the page of "Reflow profile" and "The taping dimensions".
- ◆ The dimensions of the vibration-proof products, please refer to the page of the mounting specification.

Frequency correction factor for ripple current

Rated capacitance (C)	Frequency (f)	100 Hz ≤ f < 200 Hz	200 Hz ≤ f < 300 Hz	300 Hz ≤ f < 500 Hz	500 Hz ≤ f < 1 kHz
C < 47 μF	Correction factor	0.10	0.10	0.15	0.20
47 μF ≤ C < 150 μF		0.15	0.20	0.25	0.30
150 μF ≤ C		0.15	0.25	0.25	0.30

Rated capacitance (C)	Frequency (f)	1 kHz ≤ f < 2 kHz	2 kHz ≤ f < 3 kHz	3 kHz ≤ f < 5 kHz	5 kHz ≤ f < 10 kHz
C < 47 μF	Correction factor	0.30	0.40	0.45	0.50
47 μF ≤ C < 150 μF		0.40	0.45	0.55	0.60
150 μF ≤ C		0.45	0.50	0.60	0.65

Rated capacitance (C)	Frequency (f)	10 kHz ≤ f < 15 kHz	15 kHz ≤ f < 20 kHz	20 kHz ≤ f < 30 kHz	30 kHz ≤ f < 40 kHz
C < 47 μF	Correction factor	0.60	0.65	0.70	0.75
47 μF ≤ C < 150 μF		0.70	0.75	0.80	0.80
150 μF ≤ C		0.75	0.80	0.85	0.85

Rated capacitance (C)	Frequency (f)	40 kHz ≤ f < 50 kHz	50 kHz ≤ f < 100 kHz	100 kHz ≤ f < 500 kHz	500 kHz ≤ f
C < 47 μF	Correction factor	0.80	0.85	1.00	1.05
47 μF ≤ C < 150 μF		0.85	0.90	1.00	1.00
150 μF ≤ C		0.85	0.90	1.00	1.00

**Conductive Polymer Hybrid Aluminum
Electrolytic Capacitors**
Surface Mount Type

ZTU series High temperature lead-free reflow

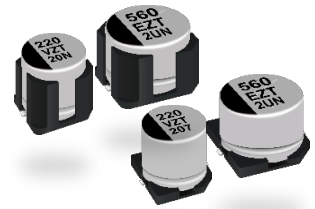

Features

- Endurance: 4000 h at 135 °C / 125 °C
- Higher ripple current (max 180 % of ZC series)
- Larger capacitance (max 170 % of ZT series)
- AEC-Q200 compliant
- RoHS compliant

Specifications

Size code	F	G
Category temp. range	-55 °C to +135 °C	
Rated voltage range	25 V to 35 V	
Nominal capacitance range	220 µF to 330 µF	390 µF to 560 µF
Capacitance tolerance	±20 % (120 Hz / +20 °C)	
Leakage current	I ≤ 0.01 CV (µA), 2 minutes after reaching rated voltage, 20 °C *CV = (Capacitance in µF) x (Rated voltage in V)	
Dissipation factor (tan δ)	Please see the attached characteristics list	
Surge voltage (V)	Rated voltage × 1.25 (15 °C to 35 °C)	
Endurance 1	+125 °C ± 2 °C, 4000 h, apply the rated ripple current without exceeding the rated voltage	
	Capacitance change	Within ±30% of the initial value
	Dissipation factor (tan δ)	≤ 200 % of the initial limit
	E.S.R.	≤ 200 % of the initial limit
	Leakage current	Within the initial limit
Endurance 2	+135 °C ± 2 °C, 4000 h, apply the rated ripple current without exceeding the rated voltage.	
	Capacitance change	Within ±30% of the initial value
	Dissipation factor (tan δ)	≤ 200 % of the initial limit
	E.S.R.	≤ 200 % of the initial limit
	Leakage current	Within the initial limit
Shelf life	After storage for 1000 hours at +135 °C ± 2 °C with no voltage applied and then being stabilized at +20 °C, capacitors shall meet the limits specified in endurance. (Capacitors are left at room temperature and humidity for 2 hours after the test. Then, apply the rated voltage for 30min with a series protection resistance of 1000 Ω ± 10 Ω. Measure electrical characteristics after discharging the capacitor.)	
	85 °C ± 2 °C, 85 % to 90 %RH, 2000 h, rated voltage applied	
Damp heat (Load)	Capacitance change	
	Dissipation factor (tan δ)	
	E.S.R.	
	Leakage current	
Resistance to soldering heat	After reflow soldering and then being stabilized at +20 °C, capacitors shall meet the following limits.	
	Capacitance change	
	Dissipation factor (tan δ)	
	Leakage current	

Marking

Example : 25 V 330 µF
Marking color : BLACK

R. voltage code	Unit : V
E	25
V	35

Dimensions (not to scale)

[Standard]

Size code	øD	L	A, B	H max.	I	W	P	K
F	8.0	10.2±0.3	8.3	10.0	3.4	0.90±0.2	3.1	0.70±0.2
G	10.0	10.2±0.3	10.3	12.0	3.5	0.90±0.2	4.6	0.70±0.2

[Vibration-proof product]

Size code	øD	L	A, B	H max.	F	I	W	P	K	R	S	T
F	8.0	10.5±0.3	8.3	10.0	0 to +0.15	3.4	1.2±0.2	3.1	0.70±0.2	0.70±0.2	5.3	1.3±0.2
G	10.0	10.5±0.3	10.3	12.0	0 to +0.15	3.5	1.2±0.2	4.6	0.70±0.2	0.70±0.2	6.9	1.3±0.2

Explanation of part numbers

◆ Part number system

e.g.: EEH^{ZT}1E³³¹U^P

EEH	ZT		1E		331		U		P	
Product classification	Series	Code	Rated voltage (V)	Code*	Capacitance (μF)	Code	Dia øD	Code	Tape width (mm)	Code
	ZT	ZT	25	1E	220	221	Miniaturized product	U	16 to 24	P
			35	1V	330	331				
					390	391				
					560	561				
Replace for the following configuration										
		Configuration		Code						
		Vibration proof		V						

*: If the total figures number of the part number exceeds 12 figures, "1" is omitted.

Characteristics list

Endurance 1 : 125 °C 4000 h

Endurance 2 : 135 °C 4000 h

Rated voltage (V)	Capacitance (±20 %) (μF)	Case size (mm)			Size code	Specification				Part number		Min. packaging q'ty (pcs)
		øD	L			Ripple current* ¹ (mA rms)	ESR* ² (mΩ)	tan δ* ³	Standard product	Vibration-proof product		
			Standard	Vibration-proof							Endurance 1 (+125°C)	Endurance 2 (+135°C)
25	330	8.0	10.2	10.5	F	2900	1800	22	0.14	EEH ^{ZT} 1E ³³¹ UP	EEH ^{ZT} 1E ³³¹ UV	500
	560	10.0	10.2	10.5	G	3500	2200	16	0.14	EEH ^{ZT} 1E ⁵⁶¹ UP	EEH ^{ZT} 1E ⁵⁶¹ UV	500
35	220	8.0	10.2	10.5	F	2900	1800	22	0.12	EEH ^{ZT} 1V ²²¹ UP	EEH ^{ZT} 1V ²²¹ UV	500
	390	10.0	10.2	10.5	G	3500	2200	16	0.12	EEH ^{ZT} 1V ³⁹¹ UP	EEH ^{ZT} 1V ³⁹¹ UV	500

*1: Ripple current (100 kHz / +125 °C or +135 °C)

*2: ESR (100 kHz / +20 °C)

*3: tan δ (120 Hz / +20 °C)

- ◆ Please refer to the page of "Reflow profile" and "The taping dimensions".
- ◆ The dimensions of the vibration-proof products, please refer to the page of the mounting specification.

Frequency correction factor for ripple current

Rated capacitance (C)	Frequency (f)			
	100 Hz ≤ f < 200 Hz	200 Hz ≤ f < 300 Hz	300 Hz ≤ f < 500 Hz	500 Hz ≤ f < 1 kHz
150 μF ≤ C	0.15	0.25	0.25	0.30
Rated capacitance (C)	Frequency (f)			
	1 kHz ≤ f < 2 kHz	2 kHz ≤ f < 3 kHz	3 kHz ≤ f < 5 kHz	5 kHz ≤ f < 10 kHz
150 μF ≤ C	0.45	0.50	0.60	0.65
Rated capacitance (C)	Frequency (f)			
	10 kHz ≤ f < 15 kHz	15 kHz ≤ f < 20 kHz	20 kHz ≤ f < 30 kHz	30 kHz ≤ f < 40 kHz
150 μF ≤ C	0.75	0.80	0.85	0.85
Rated capacitance (C)	Frequency (f)			
	40 kHz ≤ f < 50 kHz	50 kHz ≤ f < 100 kHz	100 kHz ≤ f < 500 kHz	500 kHz ≤ f < 1000 kHz
150 μF ≤ C	0.85	0.90	1.00	1.00

Conductive Polymer Hybrid Aluminum Electrolytic Capacitors

Surface Mount Type

ZV series

High temperature lead-free reflow

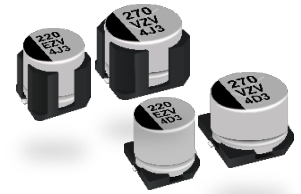

Features

- Endurance: 4000 h at 125 °C / 135 °C
- Low ESR (up to 39 %, Lower ESR than Current ZT series)
- Higher ripple current (max 150 % of ZT series)
- AEC-Q200 compliant
- RoHS compliant

Specifications

Size code	F	G
Category temp. range	-55 °C to +135 °C	
Rated voltage range	25 V to 63 V	
Nominal capacitance range	33 μF to 220 μF	56 μF to 330 μF
Capacitance tolerance	±20 % (120 Hz / +20 °C)	
Leakage current	I ≤ 0.01 CV (μA), 2 minutes after reaching rated voltage, 20 °C *CV = (Capacitance in μF) x (Rated voltage in V)	
Dissipation factor (tan δ)	Please see the attached characteristics list	
Surge voltage (V)	Rated voltage × 1.25 (15 °C to 35 °C)	
Endurance 1	+125 °C ± 2 °C, 4000 h, apply the rated ripple current without exceeding the rated voltage	
	Capacitance change	Within ±30% of the initial value
	Dissipation factor (tan δ)	≤ 200 % of the initial limit
	E.S.R.	≤ 200 % of the initial limit
	Leakage current	Within the initial limit
Endurance 2	+135 °C ± 2 °C, 4000 h, apply the rated ripple current without exceeding the rated voltage	
	Capacitance change	Within ±30% of the initial value
	Dissipation factor (tan δ)	≤ 200 % of the initial limit
	E.S.R.	≤ 200 % of the initial limit
	Leakage current	Within the initial limit
Shelf life	After storage for 1000 hours at +135 °C ± 2 °C with no voltage applied and then being stabilized at +20 °C, capacitors shall meet the limits specified in endurance. (Capacitors are left at room temperature and humidity for 2 hours after the test. Then, apply the rated voltage for 30min with a series protection resistance of 1000 Ω ± 10 Ω. Measure electrical characteristics after discharging the capacitor.)	
	85 °C ± 2 °C, 85 % to 90 %RH, 2000 h, rated voltage applied	
	Capacitance change	Within ±30% of the initial value
Damp heat (Load)	Dissipation factor (tan δ)	≤ 200 % of the initial limit
	E.S.R.	≤ 200 % of the initial limit
	Leakage current	Within the initial limit
	Resistance to soldering heat	After reflow soldering and then being stabilized at +20 °C, capacitors shall meet the following limits.
Resistance to soldering heat	Capacitance change	Within ±10% of the initial value
	Dissipation factor (tan δ)	Within the initial limit
	Leakage current	Within the initial limit

Marking

Example : 25 V 330 μF
Marking color : BLACK

Negative polarity marking (-)
Capacitance (μF)
Series identification
Lot number
Rated voltage code

R. voltage code	Unit : V
E	25
V	35
H	50
J	63

Dimensions (not to scale)

[Standard]

Size code	øD	L	A, B	H max.	I	W	P	K
F	8.0	10.2±0.3	8.3	10.0	3.4	0.90±0.2	3.1	0.70±0.2
G	10.0	10.2±0.3	10.3	12.0	3.5	0.90±0.2	4.6	0.70±0.2

[Vibration-proof product]

Size code	øD	L	A, B	H max.	F	I	W	P	K	R	S	T
F	8.0	10.5±0.3	8.3	10.0	0 to +0.15	3.4	1.2±0.2	3.1	0.70±0.2	0.70±0.2	5.3	1.3±0.2
G	10.0	10.5±0.3	10.3	12.0	0 to +0.15	3.5	1.2±0.2	4.6	0.70±0.2	0.70±0.2	6.9	1.3±0.2

Explanation of part numbers

◆ Part number system

e.g.: EEHZV1E221P

EEH	ZV		1E		221				P	
Product classification	Series	Code	Rated voltage (V)	Code*	Capacitance (μF)	Code	Capacitance (μF)	Code	Tape width (mm)	Code
	ZV	ZV	25	1E	33	330	120	121	16 to 24	P
			35	1V	47	470	150	151		
			50	1H	56	560	220	221		
			63	1J	68	680	270	271		
					82	820	330	331		
					100	101				
									Replace for the following configuration	
									Configuration	Code
									Vibration proof	V

*: If the total figures number of the part number exceeds 12 figures, "1" is omitted.

Characteristics list

Endurance 1 : 125 °C 4000 h

Endurance 2 : 135 °C 4000 h

Rated voltage (V)	Capacitance (±20 %) (μF)	Case size (mm)			Size code	Specification				Part number		Min. packaging qty (pcs)
		øD	L			Ripple current*1 (mA rms)	ESR*2 (mΩ)	tan δ*3	Standard product	Vibration-proof product	Taping	
			Standard	Vibration-proof								Endurance 1 (+125°C)
25	220	8.0	10.2	10.5	F	3900	2900	16	0.14	EEHZV1E221P	EEHZV1E221V	500
	330	10.0	10.2	10.5	G	4600	3400	12	0.14	EEHZV1E331P	EEHZV1E331V	500
35	150	8.0	10.2	10.5	F	3900	2900	16	0.12	EEHZV1V151P	EEHZV1V151V	500
	270	10.0	10.2	10.5	G	4600	3400	12	0.12	EEHZV1V271P	EEHZV1V271V	500
50	68	8.0	10.2	10.5	F	3600	2500	19	0.10	EEHZV1H680P	EEHZV1H680V	500
	100	10.0	10.2	10.5	G	4300	3200	15	0.10	EEHZV1H101P	EEHZV1H101V	500
	120	10.0	10.2	10.5	G	4300	3200	15	0.10	EEHZV1H121P	EEHZV1H121V	500
63	33	8.0	10.2	10.5	F	3300	2300	22	0.08	EEHZV1J330P	EEHZV1J330V	500
	47	8.0	10.2	10.5	F	3300	2300	22	0.08	EEHZV1J470P	EEHZV1J470V	500
	56	10.0	10.2	10.5	G	4000	3000	17	0.08	EEHZV1J560P	EEHZV1J560V	500
	68	10.0	10.2	10.5	G	4000	3000	17	0.08	EEHZV1J680P	EEHZV1J680V	500
	82	10.0	10.2	10.5	G	4000	3000	17	0.08	EEHZV1J820P	EEHZV1J820V	500

*1: Ripple current (100 kHz / +125 °C or +135 °C)

*2: ESR (100 kHz / +20 °C)

*3: tan δ (120 Hz / +20 °C)

◆ Please refer to the page of "Reflow profile" and "The taping dimensions".

◆ The dimensions of the vibration-proof products, please refer to the page of the mounting specification.

Frequency correction factor for ripple current

Rated capacitance (C)	Frequency (f)	100 Hz ≤ f < 200 Hz	200 Hz ≤ f < 300 Hz	300 Hz ≤ f < 500 Hz	500 Hz ≤ f < 1 kHz
C < 47 μF	Correction factor	0.10	0.10	0.15	0.20
47 μF ≤ C < 150 μF		0.15	0.20	0.25	0.30
150 μF ≤ C		0.15	0.25	0.25	0.30
Rated capacitance (C)	Frequency (f)	1 kHz ≤ f < 2 kHz	2 kHz ≤ f < 3 kHz	3 kHz ≤ f < 5 kHz	5 kHz ≤ f < 10 kHz
C < 47 μF	Correction factor	0.30	0.40	0.45	0.50
47 μF ≤ C < 150 μF		0.40	0.45	0.55	0.60
150 μF ≤ C		0.45	0.50	0.60	0.65
Rated capacitance (C)	Frequency (f)	10 kHz ≤ f < 15 kHz	15 kHz ≤ f < 20 kHz	20 kHz ≤ f < 30 kHz	30 kHz ≤ f < 40 kHz
C < 47 μF	Correction factor	0.60	0.65	0.70	0.75
47 μF ≤ C < 150 μF		0.70	0.75	0.80	0.80
150 μF ≤ C		0.75	0.80	0.85	0.85
Rated capacitance (C)	Frequency (f)	40 kHz ≤ f < 50 kHz	50 kHz ≤ f < 100 kHz	100 kHz ≤ f < 500 kHz	500 kHz ≤ f < 1000 kHz
C < 47 μF	Correction factor	0.80	0.85	1.00	1.05
47 μF ≤ C < 150 μF		0.85	0.90	1.00	1.00
150 μF ≤ C		0.85	0.90	1.00	1.00

Conductive Polymer Hybrid Aluminum Electrolytic Capacitors

Surface Mount Type

ZVU series **High temperature lead-free reflow**

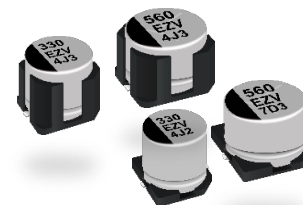

Features

- Endurance: 4000 h at 125 °C / 135 °C
- Larger capacitance (max 170 % of ZV series)
- Higher ripple current (max 150 % of ZT series)
- AEC-Q200 compliant
- RoHS compliant

Specifications

Size code	F	G
Category temp. range	-55 °C to +135 °C	
Rated voltage range	25 V to 63 V	
Nominal capacitance range	56 µF to 330 µF	100 µF to 560 µF
Capacitance tolerance	±20 % (120 Hz / +20 °C)	
Leakage current	$I \leq 0.01 CV$ (µA), 2 minutes after reaching rated voltage, 20 °C *CV = (Capacitance in µF) x (Rated voltage in V)	
Dissipation factor (tan δ)	Please see the attached characteristics list	
Surge voltage (V)	Rated voltage × 1.25 (15 °C to 35 °C)	
Endurance 1	+125 °C ± 2 °C, 4000 h, apply the rated ripple current without exceeding the rated voltage	
	Capacitance change	Within ±30% of the initial value
	Dissipation factor (tan δ)	≤ 200 % of the initial limit
	E.S.R.	≤ 200 % of the initial limit
	Leakage current	Within the initial limit
ESR after endurance (Ω / 100 kHz)(-40 °C)	Size code	
	F	G
	0.4	0.3
Endurance 2	+135 °C ± 2 °C, 4000 h, apply the rated ripple current without exceeding the rated voltage	
	Capacitance change	Within ±30% of the initial value
	Dissipation factor (tan δ)	≤ 200 % of the initial limit
	E.S.R.	≤ 200 % of the initial limit
	Leakage current	Within the initial limit
ESR after endurance (Ω / 100 kHz)(-40 °C)	Size code	
	F	G
	0.4	0.3
Shelf life	After storage for 1000 hours at +135 °C ± 2 °C with no voltage applied and then being stabilized at +20 °C, capacitors shall meet the limits specified in endurance. (Capacitors are left at room temperature and humidity for 2 hours after the test. Then, apply the rated voltage for 30min with a series protection resistance of 1000 Ω ± 10 Ω. Measure electrical characteristics after discharging the capacitor.)	
Damp heat (Load)	85 °C ± 2 °C, 85 % to 90 %RH, 2000 h, rated voltage applied	
	Capacitance change	Within ±30% of the initial value
	Dissipation factor (tan δ)	≤ 200 % of the initial limit
	E.S.R.	≤ 200 % of the initial limit
Resistance to soldering heat	After reflow soldering and then being stabilized at +20 °C, capacitors shall meet the following limits.	
	Capacitance change	Within ±10% of the initial value
	Dissipation factor (tan δ)	Within the initial limit
Leakage current	Within the initial limit	

Marking

Example : 25 V 560 µF
Marking color : BLACK

Negative polarity marking (-)
Capacitance (µF)
Series identification
Lot number
Rated voltage code

R. voltage code	Unit : V
E	25
V	35
H	50
J	63

Dimensions (not to scale)

[Standard]

Size code	øD	L	A, B	H _{max}	I	W	P	K
F	8.0	10.2±0.3	8.3	10.0	3.4	0.90±0.2	3.1	0.70±0.2
G	10.0	10.2±0.3	10.3	12.0	3.5	0.90±0.2	4.6	0.70±0.2

[Vibration-proof product]

Size code	øD	L	A, B	H _{max}	F	I	W	P	K	R	S	T
F	8.0	10.5±0.3	8.3	10.0	0 to +0.15	3.4	1.2±0.2	3.1	0.70±0.2	0.70±0.2	5.3	1.3±0.2
G	10.0	10.5±0.3	10.3	12.0	0 to +0.15	3.5	1.2±0.2	4.6	0.70±0.2	0.70±0.2	6.9	1.3±0.2

Explanation of part numbers

◆ Part number system

e.g.: EEHZV1E331UP

EEH	ZV		1E		331		U	P						
Product classification	Series	Code	Rated voltage (V)	Code *	Capacitance (μF)	Code	Capacitance (μF)	Code	Dia øD	Code	Tape width (mm)	Code		
	ZVU	ZV	25	1E	56	560	220	221	Miniaturized product	U	16 to 24	P		
			35	1V	82	820	330	331						
			50	1H	100	101	390	391						
			63	1J	150	151	560	561						
Replace for the following configuration														
										Configuration	Code			
										Vibration proof	V			

*: If the total figures number of the part number exceeds 12 figures, "1" is omitted.

Characteristics list

Endurance 1 : 125 °C 4000 h

Endurance 2 : 135 °C 4000 h

Rated voltage (V)	Capacitance (±20 %) (μF)	Case size (mm)			Size code	Specification				Part number		Min. packaging q'ty (pcs)
		øD	L			Ripple current *1 (mA rms)	ESR *2 (mΩ)	tan δ *3	Standard product	Vibration-proof product		
			Standard	Vibration-proof							Endurance 1 (+125°C)	Endurance 2 (+135°C)
25	330	8.0	10.2	10.5	F	3900	2900	16	0.14	EEHZV1E331UP	EEHZV1E331UV	500
	560	10.0	10.2	10.5	G	4600	3400	12	0.14	EEHZV1E561UP	EEHZV1E561UV	500
35	220	8.0	10.2	10.5	F	3900	2900	16	0.12	EEHZV1V221UP	EEHZV1V221UV	500
	390	10.0	10.2	10.5	G	4600	3400	12	0.12	EEHZV1V391UP	EEHZV1V391UV	500
50	82	8.0	10.2	10.5	F	3600	2500	19	0.10	EEHZV1H820UP	EEHZV1H820UV	500
	150	10.0	10.2	10.5	G	4300	3200	15	0.10	EEHZV1H151UP	EEHZV1H151UV	500
63	56	8.0	10.2	10.5	F	3300	2300	22	0.08	EEHZV1J560UP	EEHZV1J560UV	500
	100	10.0	10.2	10.5	G	4000	3000	17	0.08	EEHZV1J101UP	EEHZV1J101UV	500

*1: Ripple current (100 kHz / +125 °C or +135 °C)

*2: ESR (100 kHz / +20 °C)

*3: tan δ (120 Hz / +20 °C)

◆ Please refer to the page of "Reflow profile" and "The taping dimensions".

◆ The dimensions of the vibration-proof products, please refer to the page of the mounting specification.

Frequency correction factor for ripple current

Rated capacitance (C)	Frequency (f)	100 Hz ≤ f < 200 Hz	200 Hz ≤ f < 300 Hz	300 Hz ≤ f < 500 Hz	500 Hz ≤ f < 1 kHz
56 μF ≤ C < 150 μF	Correction	0.15	0.20	0.25	0.30
	factor	0.15	0.25	0.25	0.30
150 μF ≤ C					
Rated capacitance (C)	Frequency (f)	1 kHz ≤ f < 2 kHz	2 kHz ≤ f < 3 kHz	3 kHz ≤ f < 5 kHz	5 kHz ≤ f < 10 kHz
56 μF ≤ C < 150 μF	Correction	0.40	0.45	0.55	0.60
	factor	0.45	0.50	0.60	0.65
150 μF ≤ C					
Rated capacitance (C)	Frequency (f)	10 kHz ≤ f < 15 kHz	15 kHz ≤ f < 20 kHz	20 kHz ≤ f < 30 kHz	30 kHz ≤ f < 40 kHz
56 μF ≤ C < 150 μF	Correction	0.70	0.75	0.80	0.80
	factor	0.75	0.80	0.85	0.85
150 μF ≤ C					
Rated capacitance (C)	Frequency (f)	40 kHz ≤ f < 50 kHz	50 kHz ≤ f < 100 kHz	100 kHz ≤ f < 500 kHz	500 kHz ≤ f < 1000 kHz
56 μF ≤ C < 150 μF	Correction	0.85	0.90	1.00	1.00
	factor	0.85	0.90	1.00	1.00
150 μF ≤ C					

**Conductive Polymer Hybrid Aluminum
Electrolytic Capacitors**
Surface Mount Type

ZS series

High temperature lead-free reflow

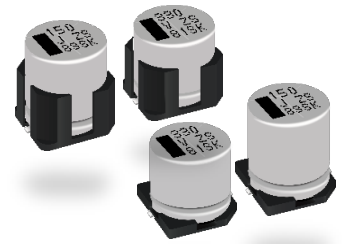

Features

- Endurance: 4000 h at 135 °C / 125 °C
- High ripple current and High capacitance
- High-withstand voltage (to 63 V)
- Vibration-proof product is available upon request.
- AEC-Q200 compliant
- RoHS compliant

Specifications

Size code	G12	G16
Category temp. range	-55 °C to +135 °C	
Rated voltage range	25 V to 63 V	
Nominal capacitance range	100 µF to 470 µF	150 µF to 560 µF
Capacitance tolerance	±20 % (120 Hz / +20 °C)	
Leakage current	$I \leq 0.01 CV$ (µA), 2 minutes after reaching rated voltage, 20 °C *CV = (Capacitance in µF) x (Rated voltage in V)	
Dissipation factor (tan δ)	Please see the attached characteristics list	
Surge voltage (V)	Rated voltage × 1.25 (15 °C to 35 °C)	
Endurance 1	+125 °C ± 2 °C, 4000 h, apply the rated ripple current without exceeding the rated voltage.	
	Capacitance change	Within ±30% of the initial value
	Dissipation factor (tan δ)	≤ 200 % of the initial limit
	E.S.R.	≤ 200 % of the initial limit
Endurance 2	+135 °C ± 2 °C, 4000 h, apply the rated ripple current without exceeding the rated voltage.	
	Capacitance change	Within ±30% of the initial value
	Dissipation factor (tan δ)	≤ 200 % of the initial limit
	E.S.R.	≤ 200 % of the initial limit
Shelf life	After storage for 1000 hours at +135 °C ± 2 °C with no voltage applied and then being stabilized at +20°C, stabilized at +20°C, capacitors shall meet the limits specified in endurance. (Capacitors are left at room temperature and humidity for 2 hours after the test. Then, apply the rated voltage for 30min with a series protection resistance of 1000 Ω ± 10 Ω. Measure electrical characteristics after discharging the capacitor.)	
Damp heat (Load)	+85 °C ± 2 °C, 85 % to 90 %RH, 2000 h, rated voltage applied.	
	Capacitance change	Within ±30% of the initial value
	Dissipation factor (tan δ)	≤ 200 % of the initial limit
	E.S.R.	≤ 200 % of the initial limit
Resistance to soldering heat	After reflow soldering and then being stabilized at +20°C, capacitors shall meet the following limits.	
	Capacitance change	Within ±10% of the initial value
	Dissipation factor (tan δ)	Within the initial limit
	Leakage current	Within the initial limit

Marking

Example : 35 V 470 µF
Marking color : BLACK

Negative polarity marking (-)

Capacitance (µF)

Series identification

Rated voltage code

Lot number

R. voltage code Unit : V

E	25
V	35
H	50
J	63

Dimensions (not to scale)

[Standard]

Pressure relief (ø10 ≦)

() Reference size

Size code	øD	L	A, B	H	I	W	P
G12	10.0	12.5	10.3	11.0±0.2	3.2	1.2±0.2	4.6
G16	10.0	16.5	10.3	11.0±0.2	3.2	1.2±0.2	4.6

Unit : mm

[Vibration-proof product]

Pressure relief (ø10 ≦)

Supportive terminals () Reference size

Size code	øD	L	A, B	H	F	I	W	P	R	S	T
G12	10.0	12.8	10.3	11.0±0.2	0 to +0.15	3.2	1.2±0.2	4.6	0.70±0.2	6.9	1.3±0.2
G16	10.0	16.8	10.3	11.0±0.2	0 to +0.15	3.2	1.2±0.2	4.6	0.70±0.2	6.9	1.3±0.2

Unit : mm

Explanation of part numbers

◆ Part number system

e.g.: EEH^{ZS}1E471P

EEH	ZS		1E		471				P	
Product classification	Series	Code	Rated voltage (V)	Code*	Capacitance (μF)	Code	Capacitance (μF)	Code	Tape width (mm)	Code
	ZS	ZS	25	1E	100	101	330	331	16 to 24	P
			35	1V	150	151	470	471		
			50	1H	220	221	560	561		
			63	1J						

Replace for the following configuration	
Configuration	Code
Vibration proof	V

*: If the total figures number of the part number exceeds 12 figures, "1" is omitted.

Characteristics list

Endurance 1 : 125 °C 4000 h

Endurance 2 : 135 °C 4000 h

Rated voltage (V)	Capacitance (±20 %) (μF)	Case size (mm)			Size code	Specification				Part number		Min. packaging q'ty (pcs)
		øD	L			Ripple current ^{*1} (mA rms)	ESR ^{*2} (mΩ)	tan δ ^{*3}	Standard product	Vibration-proof product		
			Standard	Vibration-proof							Endurance 1 (+125°C)	Endurance 2 (+135°C)
25	470	10.0	12.5	12.8	G12	3500	2500	14	0.14	EEH ^{ZS} 1E471P	EEH ^{ZS} 1E471V	400
	560	10.0	16.5	16.8	G16	4000	2900	11	0.14	EEH ^{ZS} 1E561P	EEH ^{ZS} 1E561V	250
35	330	10.0	12.5	12.8	G12	3500	2500	14	0.12	EEH ^{ZS} 1V331P	EEH ^{ZS} 1V331V	400
	470	10.0	16.5	16.8	G16	4000	2900	11	0.12	EEH ^{ZS} 1V471P	EEH ^{ZS} 1V471V	250
50	150	10.0	12.5	12.8	G12	3200	2250	17	0.10	EEH ^{ZS} 1H151P	EEH ^{ZS} 1H151V	400
	220	10.0	16.5	16.8	G16	3700	2600	13	0.10	EEH ^{ZS} 1H221P	EEH ^{ZS} 1H221V	250
63	100	10.0	12.5	12.8	G12	3000	2100	19	0.08	EEH ^{ZS} 1J101P	EEH ^{ZS} 1J101V	400
	150	10.0	16.5	16.8	G16	3500	2400	15	0.08	EEH ^{ZS} 1J151P	EEH ^{ZS} 1J151V	250

*1: Ripple current (100 kHz / +125 °C or +135 °C)

*2: ESR (100 kHz / +20 °C)

*3: tan δ (120 Hz / +20 °C)

◆ Please refer to the page of "Reflow profile" and "The taping dimensions".

◆ The dimensions of the vibration-proof products, please refer to the page of the mounting specification.

Frequency correction factor for ripple current

Rated capacitance (C)	Frequency (f)	100 Hz ≤ f < 200 Hz	200 Hz ≤ f < 300 Hz	300 Hz ≤ f < 500 Hz	500 Hz ≤ f < 1 kHz
100 μF ≤ C < 150 μF	Correction factor	0.15	0.20	0.25	0.30
	150 μF ≤ C	0.15	0.25	0.25	0.30

Rated capacitance (C)	Frequency (f)	1 kHz ≤ f < 2 kHz	2 kHz ≤ f < 3 kHz	3 kHz ≤ f < 5 kHz	5 kHz ≤ f < 10 kHz
100 μF ≤ C < 150 μF	Correction factor	0.40	0.45	0.55	0.60
	150 μF ≤ C	0.45	0.50	0.60	0.65

Rated capacitance (C)	Frequency (f)	10 kHz ≤ f < 15 kHz	15 kHz ≤ f < 20 kHz	20 kHz ≤ f < 30 kHz	30 kHz ≤ f < 40 kHz
100 μF ≤ C < 150 μF	Correction factor	0.70	0.75	0.80	0.80
	150 μF ≤ C	0.75	0.80	0.85	0.85

Rated capacitance (C)	Frequency (f)	40 kHz ≤ f < 50 kHz	50 kHz ≤ f < 100 kHz	100 kHz ≤ f < 500 kHz	500 kHz ≤ f
100 μF ≤ C < 150 μF	Correction factor	0.85	0.90	1.00	1.00
	150 μF ≤ C	0.85	0.90	1.00	1.00

**Conductive Polymer Hybrid Aluminum
Electrolytic Capacitors**
Surface Mount Type

ZSU series High temperature lead-free reflow

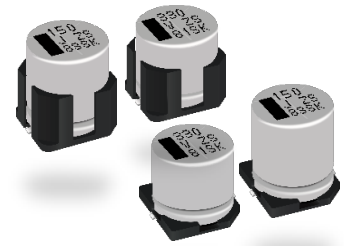

Features

- Endurance: 4000 h at 135 °C / 125 °C
- Large capacitance compared with ZS series
- Vibration-proof product is available upon request.
- AEC-Q200 compliant
- RoHS compliant

Specifications

Size code	G12		G16	
Category temp. range	-55 °C to +135 °C			
Rated voltage range	25 V to 63 V			
Nominal capacitance range	120 μF to 680 μF		180 μF to 1000 μF	
Capacitance tolerance	±20 % (120 Hz / +20 °C)			
Leakage current	$I \leq 0.01 CV (\mu A)$, 2 minutes after reaching rated voltage, 20 °C *CV = (Capacitance in μF) x (Rated voltage in V)			
Dissipation factor (tan δ)	Please see the attached characteristics list			
Surge voltage (V)	Rated voltage × 1.25 (15 °C to 35 °C)			
Endurance 1	+125 °C ± 2 °C, 4000 h, apply the rated ripple current without exceeding the rated voltage.			
	Capacitance change	Within ±30% of the initial value		
	Dissipation factor (tan δ)	≤ 200 % of the initial limit		
	E.S.R.	≤ 200 % of the initial limit		
	Leakage current	Within the initial limit		
ESR after endurance (Ω / 100 kHz)(-40 °C)	Size code			
	G12	G16		
	0.3		0.3	
Endurance 2	+135 °C ± 2 °C, 4000 h, apply the rated ripple current without exceeding the rated voltage.			
	Capacitance change	Within ±30% of the initial value		
	Dissipation factor (tan δ)	≤ 200 % of the initial limit		
	E.S.R.	≤ 200 % of the initial limit		
	Leakage current	Within the initial limit		
ESR after endurance (Ω / 100 kHz)(-40 °C)	Size code			
	G12	G16		
	0.3		0.3	
Shelf life	After storage for 1000 hours at +135 °C ± 2 °C with no voltage applied and then being stabilized at +20°C, capacitors shall meet the limits specified in endurance. (Capacitors are left at room temperature and humidity for 2 hours after the test. Then, apply the rated voltage for 30min with a series protection resistance of 1000 Ω ± 10 Ω. Measure electrical characteristics after discharging the capacitor.)			
Damp heat (Load)	+85 °C ± 2 °C, 85 % to 90 %RH, 2000 h, rated voltage applied.			
	Capacitance change	Within ±30% of the initial value		
	Dissipation factor (tan δ)	≤ 200 % of the initial limit		
	E.S.R.	≤ 200 % of the initial limit		
Resistance to soldering heat	After reflow soldering and then being stabilized at +20°C, capacitors shall meet the following limits.			
	Capacitance change	Within ±10% of the initial value		
	Dissipation factor (tan δ)	Within the initial limit		
Leakage current	Within the initial limit			

Marking

Example : 25 V 680 μF
Marking color : BLACK

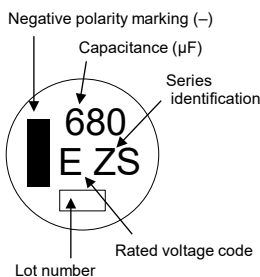

R. voltage code	Unit : V
E	25
V	35
H	50
J	63

Dimensions (not to scale)

[Standard]

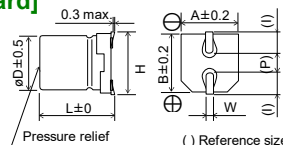

Size code	øD	L	A, B	H	I	W	P
G12	10.0	12.5	10.3	11.0±0.2	3.2	1.2±0.2	4.6
G16	10.0	16.5	10.3	11.0±0.2	3.2	1.2±0.2	4.6

[Vibration-proof product]

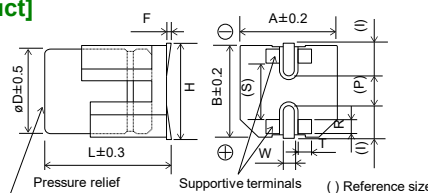

Size code	øD	L	A, B	H	F	I	W	P	R	S	T
G12	10.0	12.8	10.3	11.0±0.2	0 to +0.15	3.2	1.2±0.2	4.6	0.70±0.2	6.9	1.3±0.2
G16	10.0	16.8	10.3	11.0±0.2	0 to +0.15	3.2	1.2±0.2	4.6	0.70±0.2	6.9	1.3±0.2

Explanation of part numbers

◆ Part number system

e.g.: EEH^{ZS}1E681UP

EEH	ZS		1E		681				U		P	
Product classification	Series	Code	Rated voltage (V)	Code *	Capacitance (μF)	Code	Capacitance (μF)	Code	Dia øD	Code	Tape width (mm)	Code
	ZS	ZS	25	1E	120	121	470	471	Miniaturized product	U	16 to 24	P
			35	1V	180	181	680	681				
			50	1H	270	271	1000	102				
			63	1J								
											Replace for the following configuration	
											Configuration	Code
											Vibration proof	V

*: If the total figures number of the part number exceeds 12 figures, "1" is omitted.

Characteristics list

Endurance 1 : 125 °C 4000 h

Endurance 2 : 135 °C 4000 h

Rated voltage (V)	Capacitance (±20 %) (μF)	Case size (mm)			Size code	Specification				Part number		Min. packaging q'ty (pcs)
		øD	L			Ripple current ^{*1} (mA rms)	ESR ^{*2} (mΩ)	tan δ ^{*3}	Standard product	Vibration-proof product		
			Standard	Vibration-proof							Endurance 1 125 °C	Endurance 2 135 °C
25	680	10.0	12.5	12.8	G12	3500	2500	14	0.14	EEH ^{ZS} 1E681UP	EEH ^{ZS} 1E681UV	400
	1000	10.0	16.5	16.8	G16	4000	2900	11	0.14	EEH ^{ZS} 1E102UP	EEH ^{ZS} 1E102UV	250
35	470	10.0	12.5	12.8	G12	3500	2500	14	0.12	EEH ^{ZS} 1V471UP	EEH ^{ZS} 1V471UV	400
	680	10.0	16.5	16.8	G16	4000	2900	11	0.12	EEH ^{ZS} 1V681UP	EEH ^{ZS} 1V681UV	250
50	180	10.0	12.5	12.8	G12	3200	2250	17	0.10	EEH ^{ZS} 1H181UP	EEH ^{ZS} 1H181UV	400
	270	10.0	16.5	16.8	G16	3700	2600	13	0.10	EEH ^{ZS} 1H271UP	EEH ^{ZS} 1H271UV	250
63	120	10.0	12.5	12.8	G12	3000	2100	19	0.08	EEH ^{ZS} 1J121UP	EEH ^{ZS} 1J121UV	400
	180	10.0	16.5	16.8	G16	3500	2400	15	0.08	EEH ^{ZS} 1J181UP	EEH ^{ZS} 1J181UV	250

*1: Ripple current (100 kHz / +125 °C or 135 °C)

*2: ESR (100 kHz / +20 °C)

*3: tan δ (120 Hz / +20 °C)

◆ Please refer to the page of "Reflow profile" and "The taping dimensions".

◆ The dimensions of the vibration-proof products, please refer to the page of the mounting specification.

Frequency correction factor for ripple current

Rated capacitance (C)	Frequency (f)	100 Hz ≤ f < 120 Hz	120 Hz ≤ f < 200 Hz	200 Hz ≤ f < 300 Hz	300 Hz ≤ f < 500 Hz
120 μF ≤ C	Correction factor	0.15	0.20	0.25	0.30
Rated capacitance (C)	Frequency (f)	500 Hz ≤ f < 1 kHz	1 kHz ≤ f < 2 kHz	2 kHz ≤ f < 3 kHz	3 kHz ≤ f < 5 kHz
120 μF ≤ C	Correction factor	0.40	0.50	0.60	0.65
Rated capacitance (C)	Frequency (f)	5 kHz ≤ f < 10 kHz	10 kHz ≤ f < 15 kHz	15 kHz ≤ f < 20 kHz	20 kHz ≤ f < 30 kHz
120 μF ≤ C	Correction factor	0.70	0.75	0.80	0.85
Rated capacitance (C)	Frequency (f)	30 kHz ≤ f < 50 kHz	50 kHz ≤ f < 100 kHz	100 kHz ≤ f < 500 kHz	500 kHz ≤ f < 1000 kHz
120 μF ≤ C	Correction factor	0.85	0.90	1.00	1.00

**Conductive Polymer Hybrid Aluminum
Electrolytic Capacitors**
Surface Mount Type

ZU series

High temperature lead-free reflow

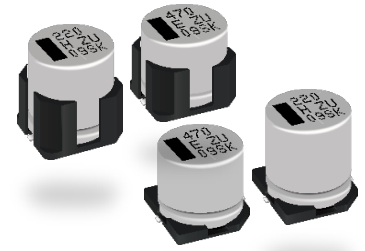

Features

- Endurance: 4000 h at 135 °C / 125 °C
- High ripple current compared with ZS series
- Vibration-proof product is available upon request.
- AEC-Q200 compliant
- RoHS compliant

Specifications

Size code	G12	G16
Category temp. range	-55 °C to +135 °C	
Rated voltage range	25 V to 63 V	
Nominal capacitance range	100 µF to 470 µF	150 µF to 560 µF
Capacitance tolerance	±20 % (120 Hz / +20 °C)	
Leakage current	I ≤ 0.01 CV (µA), 2 minutes after reaching rated voltage, 20 °C *CV = (Capacitance in µF) x (Rated voltage in V)	
Dissipation factor (tan δ)	Please see the attached characteristics list	
Surge voltage (V)	Rated voltage × 1.25 (15 °C to 35 °C)	
Endurance 1	+125 °C ± 2 °C, 4000 h, apply the rated ripple current without exceeding the rated voltage	
	Capacitance change	Within ±30% of the initial value
	Dissipation factor (tan δ)	≤ 200 % of the initial limit
	E.S.R.	≤ 200 % of the initial limit
Endurance 2	+135 °C ± 2 °C, 4000 h, apply the rated ripple current without exceeding the rated voltage	
	Capacitance change	Within ±30% of the initial value
	Dissipation factor (tan δ)	≤ 200 % of the initial limit
	E.S.R.	≤ 200 % of the initial limit
Shelf life	After storage for 1000 hours at +135 °C ± 2 °C with no voltage applied and then being stabilized at +20 °C, capacitors shall meet the limits specified in endurance. (Capacitors are left at room temperature and humidity for 2 hours after the test. Then, apply the rated voltage for 30min with a series protection resistance of 1000 Ω ± 10 Ω. Measure electrical characteristics after discharging the capacitor.)	
	85 °C ± 2 °C, 85 % to 90 %RH, 2000 h, rated voltage applied	
Damp heat (Load)	Capacitance change	
	Dissipation factor (tan δ)	
	E.S.R.	
	Leakage current	
Resistance to soldering heat	After reflow soldering and then being stabilized at +20 °C, capacitors shall meet the following limits.	
	Capacitance change	
	Dissipation factor (tan δ)	
	Leakage current	

Marking

Example : 25 V 470 µF
Marking color : BLACK

Negative polarity marking (-)

Capacitance (µF)

Series identification

Rated voltage code

Lot number

R. voltage code	Unit : V
E	25
V	35
H	50
J	63

Dimensions (not to scale)

[Standard]

Size code	øD	L	A, B	H	I	W	P
G12	10.0	12.5	10.3	11.0±0.2	3.2	1.2±0.2	4.6
G16	10.0	16.5	10.3	11.0±0.2	3.2	1.2±0.2	4.6

[Vibration-proof product]

Size code	øD	L	A, B	H	F	I	W	P	R	S	T
G12	10.0	12.8	10.3	11.0±0.2	0 to +0.15	3.2	1.2±0.2	4.6	0.70±0.2	6.9	1.3±0.2
G16	10.0	16.8	10.3	11.0±0.2	0 to +0.15	3.2	1.2±0.2	4.6	0.70±0.2	6.9	1.3±0.2

Explanation of part numbers

◆ Part number system

e.g.: EEHZU1E471P

EEH	ZU		1E		471				P	
Product classification	Series	Code	Rated voltage (V)	Code*	Capacitance (μF)	Code	Capacitance (μF)	Code	Tape width (mm)	Code
	ZU	ZU	25	1E	100	101	330	331	16 to 24	P
			35	1V	150	151	470	471		
			50	1H	220	221	560	561		
			63	1J						
									Replace for the following configuration	
									Configuration	Code
									Vibration proof	V

*: If the total figures number of the part number exceeds 12 figures, "1" is omitted.

Characteristics list

Endurance 1 : 125 °C 4000 h

Endurance 2 : 135 °C 4000 h

Rated voltage (V)	Capacitance (±20 %) (μF)	Case size (mm)			Size code	Specification				Part number		Min. packaging q'ty (pcs)
		øD	L			Ripple current ^{*1} (mA rms)	ESR ^{*2} (mΩ)	tan δ ^{*3}	Standard product	Vibration-proof product		
			Standard	Vibration-proof							Endurance 1 (+125°C)	Endurance 2 (+135°C)
25	470	10.0	12.5	12.8	G12	5000	3500	10	0.14	EEHZU1E471P	EEHZU1E471V	400
	560	10.0	16.5	16.8	G16	5800	4000	8	0.14	EEHZU1E561P	EEHZU1E561V	250
35	330	10.0	12.5	12.8	G12	4800	3300	11	0.12	EEHZU1V331P	EEHZU1V331V	400
	470	10.0	16.5	16.8	G16	5500	3800	9	0.12	EEHZU1V471P	EEHZU1V471V	250
50	150	10.0	12.5	12.8	G12	4600	3200	12	0.10	EEHZU1H151P	EEHZU1H151V	400
	220	10.0	16.5	16.8	G16	5200	3600	10	0.10	EEHZU1H221P	EEHZU1H221V	250
63	100	10.0	12.5	12.8	G12	4600	3200	12	0.08	EEHZU1J101P	EEHZU1J101V	400
	150	10.0	16.5	16.8	G16	5200	3600	10	0.08	EEHZU1J151P	EEHZU1J151V	250

*1: Ripple current (100 kHz / +125 °C or +135 °C)

*2: ESR (100 kHz / +20 °C)

*3: tan δ (120 Hz / +20 °C)

◆ Please refer to the page of "Reflow profile" and "The taping dimensions".

◆ The dimensions of the vibration-proof products, please refer to the page of the mounting specification.

Frequency correction factor for ripple current

Rated capacitance (C)	Frequency (f)	100 Hz ≤ f < 200 Hz	200 Hz ≤ f < 300 Hz	300 Hz ≤ f < 500 Hz	500 Hz ≤ f < 1 kHz
100 μF ≤ C < 150 μF	Correction factor	0.15	0.20	0.25	0.30
150 μF ≤ C		0.15	0.25	0.25	0.30
Rated capacitance (C)	Frequency (f)	1 kHz ≤ f < 2 kHz	2 kHz ≤ f < 3 kHz	3 kHz ≤ f < 5 kHz	5 kHz ≤ f < 10 kHz
100 μF ≤ C < 150 μF	Correction factor	0.40	0.45	0.55	0.60
150 μF ≤ C		0.45	0.50	0.60	0.65
Rated capacitance (C)	Frequency (f)	10 kHz ≤ f < 15 kHz	15 kHz ≤ f < 20 kHz	20 kHz ≤ f < 30 kHz	30 kHz ≤ f < 40 kHz
100 μF ≤ C < 150 μF	Correction factor	0.70	0.75	0.80	0.80
150 μF ≤ C		0.75	0.80	0.85	0.85
Rated capacitance (C)	Frequency (f)	40 kHz ≤ f < 50 kHz	50 kHz ≤ f < 100 kHz	100 kHz ≤ f < 500 kHz	500 kHz ≤ f
100 μF ≤ C < 150 μF	Correction factor	0.85	0.90	1.00	1.00
150 μF ≤ C		0.85	0.90	1.00	1.00

After endurance ESR (100 kHz, -40°C)

Size code	G12	G16
ESR (Ω)	0.3	0.3

Conductive Polymer Hybrid Aluminum Electrolytic Capacitors
Surface Mount Type

ZUU series High temperature lead-free reflow



Features

- Endurance: 4000 h at 135 °C / 125 °C
- Higher ripple current (max 160 % of ZS series)
- Larger capacitance (max 180 % of ZU series)
- AEC-Q200 compliant
- RoHS compliant

Specifications

Size code	G12		G16	
Category temp. range	-55 °C to +135 °C			
Rated voltage range	25 V to 63 V			
Nominal capacitance range	120 μF to 680 μF		180 μF to 1000 μF	
Capacitance tolerance	±20 % (120 Hz / +20 °C)			
Leakage current	I ≤ 0.01 CV (μA), 2 minutes after reaching rated voltage, 20 °C *CV = (Capacitance in μF) x (Rated voltage in V)			
Dissipation factor (tan δ)	Please see the attached characteristics list			
Surge voltage (V)	Rated voltage × 1.25 (15 °C to 35 °C)			
Endurance 1	+125 °C ± 2 °C, 4000 h, apply the rated ripple current without exceeding the rated voltage			
	Capacitance change	Within ±30% of the initial value		
	Dissipation factor (tan δ)	≤ 200 % of the initial limit		
	E.S.R.	≤ 200 % of the initial limit		
	Leakage current	Within the initial limit		
ESR after endurance (Ω / 100 kHz)(-40 °C)	Size code			
	G12	G16		
	0.3	0.3		
Endurance 2	+135 °C ± 2 °C, 4000 h, apply the rated ripple current without exceeding the rated voltage.			
	Capacitance change	Within ±30% of the initial value		
	Dissipation factor (tan δ)	≤ 200 % of the initial limit		
	E.S.R.	≤ 200 % of the initial limit		
	Leakage current	Within the initial limit		
ESR after endurance (Ω / 100 kHz)(-40 °C)	Size code			
	G12	G16		
	0.3	0.3		
Shelf life	After storage for 1000 hours at +135 °C ± 2 °C with no voltage applied and then being stabilized at +20 °C, capacitors shall meet the limits specified in endurance. (Capacitors are left at room temperature and humidity for 2 hours after the test. Then, apply the rated voltage for 30min with a series protection resistance of 1000 Ω ± 10 Ω. Measure electrical characteristics after discharging the capacitor.)			
Damp heat (Load)	85 °C ± 2 °C, 85 % to 90 %RH, 2000 h, rated voltage applied			
	Capacitance change	Within ±30% of the initial value		
	Dissipation factor (tan δ)	≤ 200 % of the initial limit		
	E.S.R.	≤ 200 % of the initial limit		
	Leakage current	Within the initial limit		
Resistance to soldering heat	After reflow soldering and then being stabilized at +20 °C, capacitors shall meet the following limits.			
	Capacitance change	Within ±10% of the initial value		
	Dissipation factor (tan δ)	Within the initial limit		
	Leakage current	Within the initial limit		

Marking

Example : 35 V 470 μF
Marking color : BLACK

Negative polarity marking (-)
Capacitance (μF)
Series identification
Rated voltage code
Lot number

R. voltage code	Unit : V
E 25	H 50
V 35	J 63

Dimensions (not to scale)

[Standard]

Size code	øD	L	A, B	H	I	W	P
G12	10.0	12.5	10.3	11.0±0.2	3.2	1.2±0.2	4.6
G16	10.0	16.5	10.3	11.0±0.2	3.2	1.2±0.2	4.6

[Vibration-proof product]

Size code	øD	L	A, B	H	F	I	W	P	R	S	T
G12	10.0	12.8	10.3	11.0±0.2	0 to +0.15	3.2	1.2±0.2	4.6	0.70±0.2	6.9	1.3±0.2
G16	10.0	16.8	10.3	11.0±0.2	0 to +0.15	3.2	1.2±0.2	4.6	0.70±0.2	6.9	1.3±0.2

Explanation of part numbers

◆ Part number system

e.g.: EEHZU1E681UP

EEH	ZU		1E		681		U		P	
Product classification	Series	Code	Rated voltage (V)	Code*	Capacitance (μF)	Code	Dia øD	Code	Tape width (mm)	Code
	ZU	ZU	25	1E	120	121	Miniaturized product	U	16 to 24	P
			35	1V	180	181				
			50	1H	270	271				
			63	1J	470	471				
					680	681				
					1000	102				
									Replace for the following configuration	
									Configuration	Code
									Vibration proof	V

*: If the total figures number of the part number exceeds 12 figures, "1" is omitted.

Characteristics list

Endurance 1 : 125 °C 4000 h

Endurance 2 : 135 °C 4000 h

Rated voltage (V)	Capacitance (±20 %) (μF)	Case size (mm)			Size code	Specification				Part number		Min. packaging q'ty (pcs)
		øD	L			Ripple current*1 (mA rms)	ESR*2 (mΩ)	tan δ*3	Standard product	Vibration-proof product		
			Standard	Vibration-proof							Endurance 1 (+125°C)	Endurance 2 (+135°C)
25	680	10.0	12.5	12.8	G12	5300	3700	10	0.14	EEHZU1E681UP	EEHZU1E681UV	400
	1000	10.0	16.5	16.8	G16	6100	4300	8	0.14	EEHZU1E102UP	EEHZU1E102UV	250
35	470	10.0	12.5	12.8	G12	5000	3500	11	0.12	EEHZU1V471UP	EEHZU1V471UV	400
	680	10.0	16.5	16.8	G16	5800	4100	9	0.12	EEHZU1V681UP	EEHZU1V681UV	250
50	180	10.0	12.5	12.8	G12	4800	3400	12	0.10	EEHZU1H181UP	EEHZU1H181UV	400
	270	10.0	16.5	16.8	G16	5500	3800	10	0.10	EEHZU1H271UP	EEHZU1H271UV	250
63	120	10.0	12.5	12.8	G12	4800	3400	12	0.08	EEHZU1J121UP	EEHZU1J121UV	400
	180	10.0	16.5	16.8	G16	5500	3800	10	0.08	EEHZU1J181UP	EEHZU1J181UV	250

*1: Ripple current (100 kHz / +125 °C or +135 °C)

*2: ESR (100 kHz / +20 °C)

*3: tan δ (120 Hz / +20 °C)

- ◆ Please refer to the page of "Reflow profile" and "The taping dimensions".
- ◆ The dimensions of the vibration-proof products, please refer to the page of the mounting specification.

Frequency correction factor for ripple current

Rated capacitance (C)	Frequency (f)	100 Hz ≤ f < 200 Hz	200 Hz ≤ f < 300 Hz	300 Hz ≤ f < 500 Hz	500 Hz ≤ f < 1 kHz
120 μF ≤ C < 150 μF	Correction factor	0.15	0.20	0.25	0.30
		0.15	0.25	0.25	0.30
150 μF ≤ C					
Rated capacitance (C)	Frequency (f)	1 kHz ≤ f < 2 kHz	2 kHz ≤ f < 3 kHz	3 kHz ≤ f < 5 kHz	5 kHz ≤ f < 10 kHz
120 μF ≤ C < 150 μF	Correction factor	0.40	0.45	0.55	0.60
		0.45	0.50	0.60	0.65
150 μF ≤ C					
Rated capacitance (C)	Frequency (f)	10 kHz ≤ f < 15 kHz	15 kHz ≤ f < 20 kHz	20 kHz ≤ f < 30 kHz	30 kHz ≤ f < 40 kHz
120 μF ≤ C < 150 μF	Correction factor	0.70	0.75	0.80	0.80
		0.75	0.80	0.85	0.85
150 μF ≤ C					
Rated capacitance (C)	Frequency (f)	40 kHz ≤ f < 50 kHz	50 kHz ≤ f < 100 kHz	100 kHz ≤ f < 500 kHz	500 kHz ≤ f < 1000 kHz
120 μF ≤ C < 150 μF	Correction factor	0.85	0.90	1.00	1.00
		0.85	0.90	1.00	1.00
150 μF ≤ C					

**Conductive Polymer Hybrid Aluminum
Electrolytic Capacitors**
Surface Mount Type

ZE series

High temperature lead-free reflow

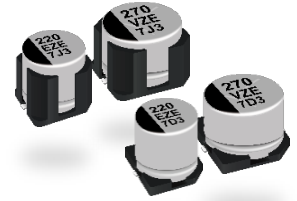

Features

- Endurance: 2000 h at 145 °C (High temperature / Long life)
- Low ESR and high ripple current
- High-withstand voltage (to 63 V)
- Characteristics dependencies in frequency and low temperature are as small as polymer type
- Vibration-proof product is available upon request
- AEC-Q200 compliant
- RoHS compliant

Specifications

Size code	F	G
Category temp. range	-55 °C to +145 °C	
Rated voltage range	25 V to 63 V	
Nominal capacitance range	33 µF to 220 µF	56 µF to 330 µF
Capacitance tolerance	±20 % (120 Hz / +20 °C)	
Leakage current	I ≤ 0.01 CV (µA), 2 minutes after reaching rated voltage, 20 °C *CV = (Capacitance in µF) x (Rated voltage in V)	
Dissipation factor (tan δ)	Please see the attached characteristics list	
Surge voltage (V)	Rated voltage × 1.25 (15 °C to 35 °C)	
Endurance 1	+145 °C ± 2 °C, 2000 h, apply the rated ripple current without exceeding the rated voltage	
	Capacitance change	Within ±30% of the initial value
	Dissipation factor (tan δ)	≤ 200 % of the initial limit
	E.S.R.	≤ 200 % of the initial limit
Endurance 2	+135 °C ± 2 °C, 4000 h, apply the rated ripple current without exceeding the rated voltage	
	Capacitance change	Within ±30% of the initial value
	Dissipation factor (tan δ)	≤ 200 % of the initial limit
	E.S.R.	≤ 200 % of the initial limit
Shelf life	After storage for 1000 hours at +145 °C ± 2 °C with no voltage applied and then being stabilized at +20 °C, capacitors shall meet the limits specified in endurance. (Capacitors are left at room temperature and humidity for 2 hours after the test. Then, apply the rated voltage for 30min with a series protection resistance of 1000 Ω ± 10 Ω. Measure electrical characteristics after discharging the capacitor.)	
	85 °C ± 2 °C, 85 % to 90 %RH, 2000 h, rated voltage applied	
Damp heat (Load)	Capacitance change	
	Dissipation factor (tan δ)	
	E.S.R.	
	Leakage current	
Resistance to soldering heat	After reflow soldering and then being stabilized at +20 °C, capacitors shall meet the following limits.	
	Capacitance change	
	Dissipation factor (tan δ)	
	Leakage current	

Marking

Example : 25 V 220 µF
Marking color : BLACK

Negative polarity marking (-)

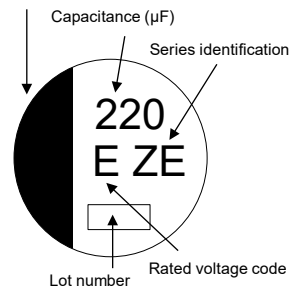

R. voltage code	Unit : V
E	25
V	35
H	50
J	63

Dimensions (not to scale)

[Standard]

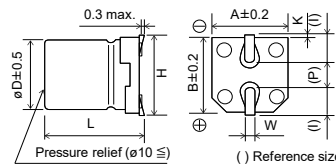

Size code	øD	L	A, B	H _{max.}	I	W	P	K
F	8.0	10.2±0.3	8.3	10	3.4	0.90±0.2	3.1	0.70±0.2
G	10.0	10.2±0.3	10.3	12.0	3.5	0.90±0.2	4.6	0.70±0.2

[Vibration-proof product]

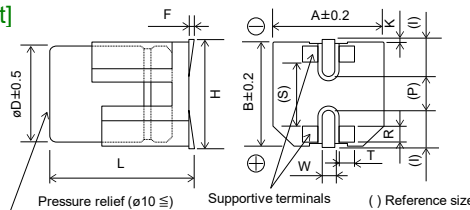

Size code	øD	L	A, B	H _{max.}	F	I	W	P	K	R	S	T
F	8.0	10.5±0.3	8.3	10.0	0 to +0.15	3.4	1.2±0.2	3.1	0.70±0.2	0.70±0.2	5.3	1.3±0.2
G	10.0	10.5±0.3	10.3	12.0	0 to +0.15	3.5	1.2±0.2	4.6	0.70±0.2	0.70±0.2	6.9	1.3±0.2

Explanation of part numbers

◆ Part number system e.g.: EEHZE1E221P

EEH	ZE		1E		221				P	
Product classification	Series	Code	Rated voltage (V)	Code*	Capacitance (μF)	Code	Capacitance (μF)	Code	Tape width (mm)	Code
	ZE	ZE	25	1E	33	330	150	151	16 to 24	P
			35	1V	56	560	220	221		
			50	1H	68	680	270	271		
			63	1J	82	820	330	331		
					100	101				

*: If the total figures number of the part number exceeds 12 figures, "1" is omitted.

Replace for the following configuration	
Configuration	Code
Vibration proof	V

Characteristics list

Endurance 1 : 145 °C 2000 h

Endurance 2 : 135 °C 4000 h

Rated voltage (V)	Capacitance (±20 %) (μF)	Case size (mm)			Size code	Specification				Part number		Min. packaging q'ty (pcs)
		øD	L			Ripple current* ¹ (mA rms)	ESR* ² (mΩ)	tan δ* ³	Standard product	Vibration-proof product		
			Standard	Vibration-proof							Endurance 1 (+145°C)	Endurance 2 (+135°C)
25	220	8.0	10.2	10.5	F	700	1600	27	0.14	EEHZE1E221P	EEHZE1E221V	500
	330	10.0	10.2	10.5	G	900	2000	20	0.14	EEHZE1E331P	EEHZE1E331V	500
35	150	8.0	10.2	10.5	F	700	1600	27	0.12	EEHZE1V151P	EEHZE1V151V	500
	270	10.0	10.2	10.5	G	900	2000	20	0.12	EEHZE1V271P	EEHZE1V271V	500
50	68	8.0	10.2	10.5	F	600	1250	30	0.10	EEHZE1H680P	EEHZE1H680V	500
	100	10.0	10.2	10.5	G	800	1600	28	0.10	EEHZE1H101P	EEHZE1H101V	500
63	33	8.0	10.2	10.5	F	600	1100	40	0.08	EEHZE1J330P	EEHZE1J330V	500
	56	10.0	10.2	10.5	G	800	1400	30	0.08	EEHZE1J560P	EEHZE1J560V	500
	82	10.0	10.2	10.5	G	800	1400	30	0.08	EEHZE1J820P	EEHZE1J820V	500

*1: Ripple current (100 kHz / +145 °C or +135 °C) *2: ESR (100 kHz / +20 °C) *3: tan δ (120 Hz / +20 °C)

- ◆ Please refer to the page of "Reflow profile" and "The taping dimensions".
- ◆ The dimensions of the vibration-proof products, please refer to the page of the mounting specification.

Frequency correction factor for ripple current

Rated capacitance (C)	Frequency (f)	100 Hz ≤ f < 200 Hz	200 Hz ≤ f < 300 Hz	300 Hz ≤ f < 500 Hz	500 Hz ≤ f < 1 kHz
C < 47 μF	Correction factor	0.10	0.10	0.15	0.20
47 μF ≤ C < 150 μF		0.15	0.20	0.25	0.30
150 μF ≤ C		0.15	0.25	0.25	0.30

Rated capacitance (C)	Frequency (f)	1 kHz ≤ f < 2 kHz	2 kHz ≤ f < 3 kHz	3 kHz ≤ f < 5 kHz	5 kHz ≤ f < 10 kHz
C < 47 μF	Correction factor	0.30	0.40	0.45	0.50
47 μF ≤ C < 150 μF		0.40	0.45	0.55	0.60
150 μF ≤ C		0.45	0.50	0.60	0.65

Rated capacitance (C)	Frequency (f)	10 kHz ≤ f < 15 kHz	15 kHz ≤ f < 20 kHz	20 kHz ≤ f < 30 kHz	30 kHz ≤ f < 40 kHz
C < 47 μF	Correction factor	0.60	0.65	0.70	0.75
47 μF ≤ C < 150 μF		0.70	0.75	0.80	0.80
150 μF ≤ C		0.75	0.80	0.85	0.85

Rated capacitance (C)	Frequency (f)	40 kHz ≤ f < 50 kHz	50 kHz ≤ f < 100 kHz	100 kHz ≤ f < 500 kHz	500 kHz ≤ f
C < 47 μF	Correction factor	0.80	0.85	1.00	1.05
47 μF ≤ C < 150 μF		0.85	0.90	1.00	1.00
150 μF ≤ C		0.85	0.90	1.00	1.00

After endurance ESR (100 kHz, -40°C)

Size code	F	G
ESR (Ω)	0.4	0.3

Conductive Polymer Hybrid Aluminum Electrolytic Capacitors

Surface Mount Type

ZF series

High temperature lead-free reflow

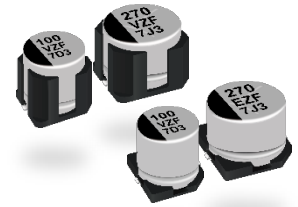

Features

- Endurance : 1000 h at 150 °C (High temperature)
- Low ESR and high ripple current
- High-withstand voltage (to 63 V)
- Vibration-proof product is available upon request
- AEC-Q200 compliant
- RoHS compliant

Specifications

Size code	F	G
Category temp. range	-55 °C to +150 °C	
Rated voltage range	25 V to 63 V	
Nominal capacitance range	33 µF to 150 µF	56 µF to 270 µF
Capacitance tolerance	±20 % (120 Hz / +20°C)	
Leakage current	$I \leq 0.01 CV (\mu A)$, 2 minutes after reaching rated voltage, 20 °C *CV = (Capacitance in µF) x (Rated voltage in V)	
Dissipation factor (tan δ)	Please see the attached characteristics list	
Surge voltage (V)	Rated voltage × 1.25 (15 °C to 35 °C)	
Endurance	+150 °C ± 2 °C, 1000 h, apply the rated ripple current without exceeding the rated voltage.	
	Capacitance change	Within ±30% of the initial value
	Dissipation factor (tan δ)	≤ 200 % of the initial limit
	ESR	≤ 200 % of the initial limit
	Leakage current	Within the initial limit
ESR after endurance (Ω / 100 kHz)(-40 °C)	Size code	
	F	G
	0.4	0.3
Shelf life	After storage for 1000 hours at +150 °C ± 2 °C with no voltage applied and then being stabilized at +20 °C, capacitors shall meet the limits specified in endurance.	
	(Capacitors are left at room temperature and humidity for 2 hours after the test. Then, apply the rated voltage for 30min with a series protection resistance of 1000 Ω ± 10 Ω. Measure electrical characteristics after discharging the capacitor.)	
Damp heat (Load)	+85 °C ± 2 °C, 85 % to 90 %RH, 2000 h, rated voltage applied	
	Capacitance change	Within ±30% of the initial value
	Dissipation factor (tan δ)	≤ 200 % of the initial limit
	ESR	≤ 200 % of the initial limit
	Leakage current	Within the initial limit
Resistance to soldering heat	After reflow soldering and then being stabilized at +20 °C, capacitors shall meet the following limits.	
	Capacitance change	Within ±10% of the initial value
	Dissipation factor (tan δ)	Within the initial limit
	Leakage current	Within the initial limit

Marking

Example : 25 V 150 µF
Marking color : BLACK

Negative polarity marking (-)

Capacitance (µF)

Series identification

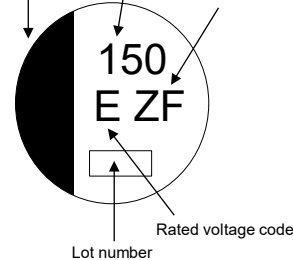

Rated voltage code

Lot number

R. voltage code	Unit : V
E	25
V	35
H	50
J	63

Dimensions (not to scale)

[Standard]

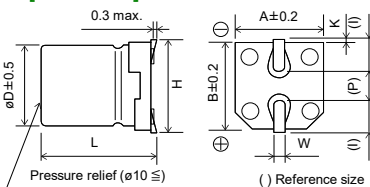

Size code	øD	L	A, B	H _{max}	I	W	P	K
F	8.0	10.2±0.3	8.3	10	3.4	0.90±0.2	3.1	0.70±0.2
G	10.0	10.2±0.3	10.3	12.0	3.5	0.90±0.2	4.6	0.70±0.2

[Vibration-proof product]

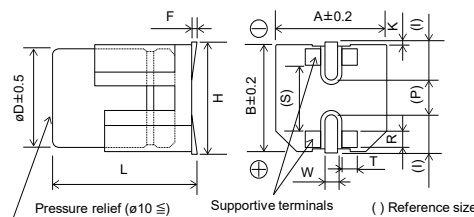

Size code	øD	L	A, B	H _{max}	F	I	W	P	K	R	S	T
F	8.0	10.5±0.3	8.3	10.0	0 to +0.15	3.4	1.2±0.2	3.1	0.70±0.2	0.70±0.2	5.3	1.3±0.2
G	10.0	10.5±0.3	10.3	12.0	0 to +0.15	3.5	1.2±0.2	4.6	0.70±0.2	0.70±0.2	6.9	1.3±0.2

Explanation of part numbers

◆ Part number system e.g.: EEHZF1E151P

EEH	ZF		1E		151				P	
Product classification	Series	Code	Rated voltage (V)	Code*	Capacitance (μF)	Code	Capacitance (μF)	Code	Tape width (mm)	Code
	ZF	ZF	25	1E	33	330	150	151	16 to 24	P
			35	1V	56	560	270	271		
			50	1H	100	101				
			63	1J						

*: If the total figures number of the part number exceeds 12 figures, "1" is omitted.

Replace for the following configuration	
Configuration	Code
Vibration proof	V

Characteristics list

Endurance : 150 °C 1000 h

Rated voltage (V)	Capacitance (±20 %) (μF)	Case size (mm)			Size code	Specification			Part number		Min. packaging q'ty (pcs)
		øD	L			Ripple current* ¹ (mA rms)	ESR* ² (mΩ)	tan δ* ³	Standard product	Vibration-proof product	Taping
			Standard	Vibration-proof							
25	150	8.0	10.2	10.5	F	800	27	0.14	EEHZF1E151P	EEHZF1E151V	500
	270	10.0	10.2	10.5	G	1000	20	0.14	EEHZF1E271P	EEHZF1E271V	500
35	100	8.0	10.2	10.5	F	770	30	0.12	EEHZF1V101P	EEHZF1V101V	500
	150	10.0	10.2	10.5	G	950	23	0.12	EEHZF1V151P	EEHZF1V151V	500
50	56	8.0	10.2	10.5	F	700	35	0.10	EEHZF1H560P	EEHZF1H560V	500
	100	10.0	10.2	10.5	G	900	28	0.10	EEHZF1H101P	EEHZF1H101V	500
63	33	8.0	10.2	10.5	F	650	40	0.08	EEHZF1J330P	EEHZF1J330V	500
	56	10.0	10.2	10.5	G	840	30	0.08	EEHZF1J560P	EEHZF1J560V	500

*1: Ripple current (100 kHz / +150 °C)

*2: ESR (100 kHz / +20 °C)

*3: tan δ (120 Hz / +20 °C)

◆ Please refer to the page of "Reflow profile" and "The taping dimensions".

◆ The dimensions of the vibration-proof products, please refer to the page of the mounting specification.

Frequency correction factor for ripple current

Rated capacitance (C)	Frequency (f)	100 Hz ≤ f < 200 Hz	200 Hz ≤ f < 300 Hz	300 Hz ≤ f < 500 Hz	500 Hz ≤ f < 1 kHz
C < 47 μF	Correction factor	0.10	0.10	0.15	0.20
47 μF ≤ C < 150 μF		0.15	0.20	0.25	0.30
150 μF ≤ C		0.15	0.25	0.25	0.30

Rated capacitance (C)	Frequency (f)	1 kHz ≤ f < 2 kHz	2 kHz ≤ f < 3 kHz	3 kHz ≤ f < 5 kHz	5 kHz ≤ f < 10 kHz
C < 47 μF	Correction factor	0.30	0.40	0.45	0.50
47 μF ≤ C < 150 μF		0.40	0.45	0.55	0.60
150 μF ≤ C		0.45	0.50	0.60	0.65

Rated capacitance (C)	Frequency (f)	10 kHz ≤ f < 15 kHz	15 kHz ≤ f < 20 kHz	20 kHz ≤ f < 30 kHz	30 kHz ≤ f < 40 kHz
C < 47 μF	Correction factor	0.60	0.65	0.70	0.75
47 μF ≤ C < 150 μF		0.70	0.75	0.80	0.80
150 μF ≤ C		0.75	0.80	0.85	0.85

Rated capacitance (C)	Frequency (f)	40 kHz ≤ f < 50 kHz	50 kHz ≤ f < 100 kHz	100 kHz ≤ f < 500 kHz	500 kHz ≤ f
C < 47 μF	Correction factor	0.80	0.85	1.00	1.05
47 μF ≤ C < 150 μF		0.85	0.90	1.00	1.00
150 μF ≤ C		0.85	0.90	1.00	1.00

**Conductive Polymer Hybrid Aluminum
Electrolytic Capacitors**
Radial Lead Type
ZA-A series

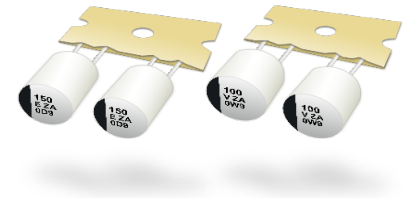

Features

- Endurance : 10000 h at 105 °C (105 °C standard product)
- Taping products for automatic insertion
- AEC-Q200 compliant
- RoHS compliant

Specifications

Size code	F		G	
Category temp. range	-55 °C to +105 °C			
Rated voltage range	25 V to 80 V			
Nominal capacitance range	22 µF to 220 µF		33 µF to 330 µF	
Capacitance tolerance	±20 % (120 Hz / +20°C)			
Leakage current	$I \leq 0.01 CV$ (µA), 2 minutes after reaching rated voltage, 20 °C *CV = (Capacitance in µF) x (Rated voltage in V)			
Dissipation factor (tan δ)	Please see the attached characteristics list			
Surge voltage (V)	Rated voltage × 1.25 (15 °C to 35 °C)			
Endurance	+105 °C ± 2 °C, 10000 h, apply the rated ripple current without exceeding the rated voltage.			
	Capacitance change	Within ±30% of the initial value		
	Dissipation factor (tan δ)	≤ 200 % of the initial limit		
	ESR	≤ 200 % of the initial limit		
	Leakage current	Within the initial limit		
ESR after endurance (Ω / 100 kHz)(-40 °C)	Size code			
	F	G		
	0.4	0.3		
Shelf life	After storage for 1000 hours at +105 °C ± 2 °C with no voltage applied and then being stabilized at +20 °C, capacitors shall meet the limits specified in endurance. (Capacitors are left at room temperature and humidity for 2 hours after the test. Then, apply the rated voltage for 30min with a series protection resistance of 1000 Ω ± 10 Ω. Measure electrical characteristics after discharging the capacitor.)			
Damp heat (Load)	+85 °C ± 2 °C, 85 % to 90 %RH, 2000 h, rated voltage applied			
	Capacitance change	Within ±30% of the initial value		
	Dissipation factor (tan δ)	≤ 200 % of the initial limit		
	ESR	≤ 200 % of the initial limit		
	Leakage current	Within the initial limit		
Resistance to soldering heat	After flow soldering and then being stabilized at +20 °C, capacitors shall meet the following limits.			
	Capacitance change	Within ±10% of the initial value		
	Dissipation factor (tan δ)	Within the initial limit		
	Leakage current	Within the initial limit		

Marking

Example : 25 V 150 µF
Marking color : BLACK

Negative polarity marking (-)

Capacitance (µF)

Series identification

Rated voltage code

Lot number

R.voltage code	Unit : V
E	25
V	35
H	50
J	63
K	80

Dimensions (not to scale)

Size code	øD	L	ød	F	P1
F	8.0	9.5	0.6	3.5±0.5	4.60±0.50
G	10.0	9.5	0.6	5.0 ^{+0.8} _{-0.2}	3.85±0.50

Unit : mm

Explanation of part numbers

◆ Part number system e.g.: EEHAZA1E151B

EEHA	ZA		1E		151		B			
Product classification	Series	Code	Rated voltage (V)	Code*	Capacitance (μF)	Code	Capacitance (μF)	Code	Lead space (mm)	Code
	ZA	ZA	25	1E	22	220	82	820	3.5, 5.0	B
			35	1V	33	330	100	101		
			50	1H	47	470	150	151		
			63	1J	56	560	220	221		
			80	1K	68	680	330	331		

*: If the total figures number of the part number exceeds 12 figures, "1" is omitted.

Characteristics list

Endurance : 105 °C 10000 h

Rated voltage (V)	Capacitance (±20 %) (μF)	Case size (mm)			Size code	Specification			Part number	Min. packaging q'ty (pcs)
		øD	L	ød		Ripple current *1 (mA rms)	ESR*2 (mΩ)	tan δ*3		Taping
25	150	8.0	9.5	0.6	F	2300	27	0.14	EEHAZA1E151B	1000
	220	8.0	9.5	0.6	F	2300	27	0.14	EEHAZA1E221B	1000
	330	10.0	9.5	0.6	G	2500	20	0.14	EEHAZA1E331B	500
35	100	8.0	9.5	0.6	F	2300	27	0.12	EEHAZA1V101B	1000
	150	8.0	9.5	0.6	F	2300	27	0.12	EEHAZA1V151B	1000
	220	10.0	9.5	0.6	G	2500	20	0.12	EEHAZA1V221B	500
50	270	10.0	9.5	0.6	G	2500	20	0.12	EEHAZA1V271B	500
	47	8.0	9.5	0.6	F	1800	30	0.10	EEHAZA1H470B	1000
	68	8.0	9.5	0.6	F	1800	30	0.10	EEHAZA1H680B	1000
63	100	10.0	9.5	0.6	G	2000	28	0.10	EEHAZA1H101B	500
	33	8.0	9.5	0.6	F	1700	40	0.08	EEHAZA1J330B	1000
	47	8.0	9.5	0.6	F	1700	40	0.08	EEHAZA1J470B	1000
80	56	10.0	9.5	0.6	G	1800	30	0.08	EEHAZA1J560B	500
	68	10.0	9.5	0.6	G	1800	30	0.08	EEHAZA1J680B	500
	82	10.0	9.5	0.6	G	1800	30	0.08	EEHAZA1J820B	500
80	22	8.0	9.5	0.6	F	1550	45	0.08	EEHAZA1K220B	1000
	33	10.0	9.5	0.6	G	1700	36	0.08	EEHAZA1K330B	500
	47	10.0	9.5	0.6	G	1700	36	0.08	EEHAZA1K470B	500

*1: Ripple current (100 kHz / +105 °C)

*2: ESR (100 kHz / +20 °C)

*3: tan δ (120 Hz / +20 °C)

◆ Please refer to the page of "Flow soldering profile" and "The taping dimensions".

Frequency correction factor for ripple current

Rated capacitance (C)	Frequency (f)	100 Hz ≤ f < 200 Hz	200 Hz ≤ f < 300 Hz	300 Hz ≤ f < 500 Hz	500 Hz ≤ f < 1 kHz
C < 47 μF	Correction factor	0.10	0.10	0.15	0.20
47 μF ≤ C < 150 μF		0.15	0.20	0.25	0.30
150 μF ≤ C		0.15	0.25	0.25	0.30
Rated capacitance (C)	Frequency (f)	1 kHz ≤ f < 2 kHz	2 kHz ≤ f < 3 kHz	3 kHz ≤ f < 5 kHz	5 kHz ≤ f < 10 kHz
C < 47 μF	Correction factor	0.30	0.40	0.45	0.50
47 μF ≤ C < 150 μF		0.40	0.45	0.55	0.60
150 μF ≤ C		0.45	0.50	0.60	0.65
Rated capacitance (C)	Frequency (f)	10 kHz ≤ f < 15 kHz	15 kHz ≤ f < 20 kHz	20 kHz ≤ f < 30 kHz	30 kHz ≤ f < 40 kHz
C < 47 μF	Correction factor	0.60	0.65	0.70	0.75
47 μF ≤ C < 150 μF		0.70	0.75	0.80	0.80
150 μF ≤ C		0.75	0.80	0.85	0.85
Rated capacitance (C)	Frequency (f)	40 kHz ≤ f < 50 kHz	50 kHz ≤ f < 100 kHz	100 kHz ≤ f < 500 kHz	500 kHz ≤ f < 1000 kHz
C < 47 μF	Correction factor	0.80	0.85	1.00	1.05
47 μF ≤ C < 150 μF		0.85	0.90	1.00	1.00
150 μF ≤ C		0.85	0.90	1.00	1.00

Design and specifications are each subject to change without notice. Ask factory for the current technical specifications before purchase and/or use.
Should a safety concern arise regarding this product, please be sure to contact us immediately.

**Conductive Polymer Hybrid Aluminum
Electrolytic Capacitors**
Radial Lead Type
ZC-A series

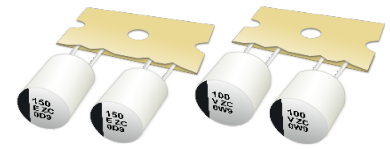

Features

- Endurance : 4000 h at 125 °C (125 °C standard product)
- Taping products for automatic insertion
- AEC-Q200 compliant
- RoHS compliant

Specifications

Size code	F	G
Category temp. range	-55 °C to +125 °C	
Rated voltage range	25 V to 80 V	
Nominal capacitance range	22 µF to 220 µF	33 µF to 330 µF
Capacitance tolerance	±20 % (120 Hz / +20°C)	
Leakage current	I ≤ 0.01 CV (µA), 2 minutes after reaching rated voltage, 20 °C *CV = (Capacitance in µF) x (Rated voltage in V)	
Dissipation factor (tan δ)	Please see the attached characteristics list	
Surge voltage (V)	Rated voltage × 1.25 (15 °C to 35 °C)	
Endurance 1	+125 °C ± 2 °C, 4000 h, apply the rated ripple current without exceeding the rated voltage.	
	Capacitance change	Within ±30% of the initial value
	Dissipation factor (tan δ)	≤ 200 % of the initial limit
	ESR	≤ 200 % of the initial limit
Endurance 2	+125 °C ± 2 °C, 3000 h, apply the rated ripple current without exceeding the rated voltage.	
	Capacitance change	Within ±30% of the initial value
	Dissipation factor (tan δ)	≤ 200 % of the initial limit
	ESR	≤ 300 % of the initial limit
Shelf life	After storage for 1000 hours at +125 °C ± 2 °C with no voltage applied and then being stabilized at +20 °C, capacitors shall meet the limits specified in endurance 1. (Capacitors are left at room temperature and humidity for 2 hours after the test. Then, apply the rated voltage for 30min with a series protection resistance of 1000 Ω ± 10 Ω. Measure electrical characteristics after discharging the capacitor.)	
	+85 °C ± 2 °C, 85 % to 90 %RH, 2000 h, rated voltage applied	
Damp heat (Load)	Capacitance change	
	Dissipation factor (tan δ)	
	ESR	
	Leakage current	
Resistance to soldering heat	After flow soldering and then being stabilized at +20 °C, capacitors shall meet the following limits.	
	Capacitance change	
	Dissipation factor (tan δ)	
	Leakage current	

Marking

Example : 25 V 150 µF
Marking color : BLACK

Negative polarity marking (-)

Capacitance (µF)

Series identification

Rated voltage code

Lot number

R.voltage code	Unit : V
E	25
V	35
H	50
J	63
K	80

Dimensions (not to scale)

Size code	øD	L	ød	F	P1
F	8.0	9.5	0.6	3.5±0.5	4.60±0.50
G	10.0	9.5	0.6	5.0 ^{+0.8} _{-0.2}	3.85±0.50

Unit : mm

Explanation of part numbers

◆ Part number system e.g.: EEHAZC1E151B

EEHA	ZC		1E		151				B	
Product classification	Series	Code	Rated voltage (V)	Code*	Capacitance (μF)	Code	Capacitance (μF)	Code	Lead space (mm)	Code
	ZC	ZC	25	1E	22	220	100	101	3.5, 5.0	B
			35	1V	33	330	120	121		
			50	1H	47	470	150	151		
			63	1J	56	560	220	221		
			80	1K	68	680	270	271		
					82	820	330	331		

*: If the total figures number of the part number exceeds 12 figures, "1" is omitted.

Characteristics list

Endurance 1 : 125 °C 4000 h

Endurance 2 : 125 °C 3000 h

Rated voltage (V)	Capacitance (±20 %) (μF)	Case size (mm)			Size code	Specification				Part number	Min. packaging q'ty (pcs)
		øD	L	ød		Ripple current*1 (mA rms)		ESR*2 (mΩ)	tan δ*3		Taping
						Endurance 1	Endurance 2				
25	150	8.0	9.5	0.6	F	1600	1900	27	0.14	EEHAZC1E151B	1000
	220	8.0	9.5	0.6	F	1600	1900	27	0.14	EEHAZC1E221B	1000
	330	10.0	9.5	0.6	G	2000	2900	20	0.14	EEHAZC1E331B	500
35	100	8.0	9.5	0.6	F	1600	1900	27	0.12	EEHAZC1V101B	1000
	150	8.0	9.5	0.6	F	1600	1900	27	0.12	EEHAZC1V151B	1000
	220	10.0	9.5	0.6	G	2000	2800	20	0.12	EEHAZC1V221B	500
50	270	10.0	9.5	0.6	G	2000	2800	20	0.12	EEHAZC1V271B	500
	47	8.0	9.5	0.6	F	1250	-	30	0.10	EEHAZC1H470B	1000
	68	8.0	9.5	0.6	F	1250	-	30	0.10	EEHAZC1H680B	1000
80	100	10.0	9.5	0.6	G	1600	-	28	0.10	EEHAZC1H101B	500
	120	10.0	9.5	0.6	G	1600	-	28	0.10	EEHAZC1H121B	500
	33	8.0	9.5	0.6	F	1100	-	40	0.08	EEHAZC1J330B	1000
63	47	8.0	9.5	0.6	F	1100	-	40	0.08	EEHAZC1J470B	1000
	56	10.0	9.5	0.6	G	1400	-	30	0.08	EEHAZC1J560B	500
	68	10.0	9.5	0.6	G	1400	-	30	0.08	EEHAZC1J680B	500
	82	10.0	9.5	0.6	G	1400	-	30	0.08	EEHAZC1J820B	500
80	22	8.0	9.5	0.6	F	1050	-	45	0.08	EEHAZC1K220B	1000
	33	10.0	9.5	0.6	G	1360	-	36	0.08	EEHAZC1K330B	500
	47	10.0	9.5	0.6	G	1360	-	36	0.08	EEHAZC1K470B	500

*1: Ripple current (100 kHz / +125 °C)

*2: ESR (100 kHz / +20 °C)

*3: tan δ (120 Hz / +20 °C)

◆ Please refer to the page of "Flow soldering profile" and "The taping dimensions".

Frequency correction factor for ripple current

Rated capacitance (C)	Frequency (f)	100 Hz ≤ f < 200 Hz	200 Hz ≤ f < 300 Hz	300 Hz ≤ f < 500 Hz	500 Hz ≤ f < 1 kHz
C < 47 μF	Correction factor	0.10	0.10	0.15	0.20
47 μF ≤ C < 150 μF		0.15	0.20	0.25	0.30
150 μF ≤ C		0.15	0.25	0.25	0.30

Rated capacitance (C)	Frequency (f)	1 kHz ≤ f < 2 kHz	2 kHz ≤ f < 3 kHz	3 kHz ≤ f < 5 kHz	5 kHz ≤ f < 10 kHz
C < 47 μF	Correction factor	0.30	0.40	0.45	0.50
47 μF ≤ C < 150 μF		0.40	0.45	0.55	0.60
150 μF ≤ C		0.45	0.50	0.60	0.65

Rated capacitance (C)	Frequency (f)	10 kHz ≤ f < 15 kHz	15 kHz ≤ f < 20 kHz	20 kHz ≤ f < 30 kHz	30 kHz ≤ f < 40 kHz
C < 47 μF	Correction factor	0.60	0.65	0.70	0.75
47 μF ≤ C < 150 μF		0.70	0.75	0.80	0.80
150 μF ≤ C		0.75	0.80	0.85	0.85

Rated capacitance (C)	Frequency (f)	40 kHz ≤ f < 50 kHz	50 kHz ≤ f < 100 kHz	100 kHz ≤ f < 500 kHz	500 kHz ≤ f < 1000 kHz
C < 47 μF	Correction factor	0.80	0.85	1.00	1.05
47 μF ≤ C < 150 μF		0.85	0.90	1.00	1.00
150 μF ≤ C		0.85	0.90	1.00	1.00

After endurance ESR (100 kHz, -40 °C)

Size code	F (ø8 x L9.5)	G (ø10 x L9.5)
ESR (Ω)	0.4	0.3



Conductive Polymer Hybrid Aluminum Electrolytic Capacitors

Radial Lead Type

ZK-A series

Features

- Endurance : 4000 h at 125 °C (Large capacitance / High ripple current)
- Taping products for automatic insertion
- AEC-Q200 compliant
- RoHS compliant

Specifications

Size code	F	G
Category temp. range	-55 °C to +125 °C	
Rated voltage range	25 V to 35 V	
Nominal capacitance range	180 µF to 270 µF	330 µF to 470 µF
Capacitance tolerance	±20 % (120 Hz / +20°C)	
Leakage current	$I \leq 0.01 CV$ (µA), 2 minutes after reaching rated voltage, 20 °C *CV = (Capacitance in µF) x (Rated voltage in V)	
Dissipation factor (tan δ)	Please see the attached characteristics list	
Surge voltage (V)	Rated voltage × 1.25 (15 °C to 35 °C)	
Endurance	+125 °C ± 2 °C, 4000 h, apply the rated ripple current without exceeding the rated voltage.	
	Capacitance change	Within ±30% of the initial value
	Dissipation factor (tan δ)	≤ 200 % of the initial limit
	ESR	≤ 200 % of the initial limit
	Leakage current	Within the initial limit
ESR after endurance (Ω / 100 kHz)(-40 °C)	Size code	
	F	G
	0.4	0.3
Shelf life	After storage for 1000 hours at +125 °C ± 2 °C with no voltage applied and then being stabilized at +20 °C, capacitors shall meet the limits specified in endurance. (Capacitors are left at room temperature and humidity for 2 hours after the test. Then, apply the rated voltage for 30min with a series protection resistance of 1000 Ω ± 10 Ω. Measure electrical characteristics after discharging the capacitor.)	
Damp heat (Load)	+85 °C ± 2 °C, 85 % to 90 %RH, 2000 h, rated voltage applied	
	Capacitance change	Within ±30% of the initial value
	Dissipation factor (tan δ)	≤ 200 % of the initial limit
	ESR	≤ 200 % of the initial limit
Resistance to soldering heat	After flow soldering and then being stabilized at +20 °C, capacitors shall meet the following limits.	
	Capacitance change	Within ±10% of the initial value
	Dissipation factor (tan δ)	Within the initial limit
	Leakage current	
	Within the initial limit	

Marking

Example : 25 V 270 µF
Marking color : BLACK

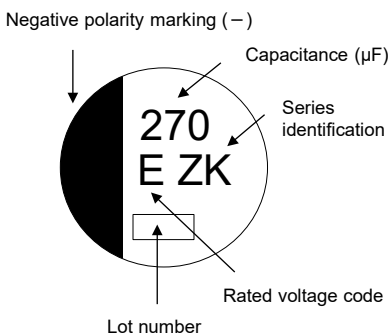

R.voltage code	Unit : V
E	25
V	35

Dimensions (not to scale)

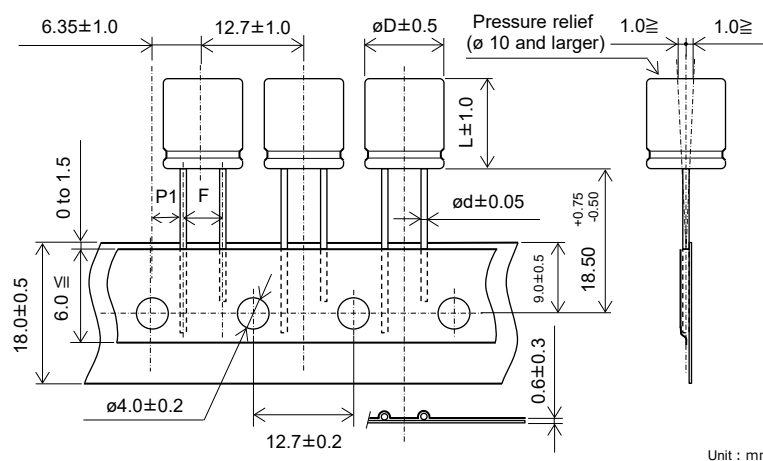

Size code	øD	L	ød	F	P1
F	8.0	9.5	0.6	3.5±0.5	4.60±0.50
G	10.0	9.5	0.6	5.0 ^{+0.8} _{-0.2}	3.85±0.50

Unit : mm

Explanation of part numbers

◆ Part number system e.g.: EEHAZK1E271B

EEHA	ZK		1E		271				B	
Product classification	Series	Code	Rated voltage (V)	Code*	Capacitance (μF)	Code	Capacitance (μF)	Code	Lead space (mm)	Code
	ZK	ZK	25	1E	180	181	330	331	3.5, 5.0	B
			35	1V	270	271	470	471		

*: If the total figures number of the part number exceeds 12 figures, "1" is omitted.

Characteristics list

Endurance : 125 °C 4000 h

Rated voltage (V)	Capacitance (±20 %) (μF)	Case size (mm)			Size code	Specification			Part number	Min. packaging q'ty (pcs)
		øD	L	ød		Ripple current ^{*1} (mA rms)	ESR ^{*2} (mΩ)	tan δ ^{*3}		Taping
25	270	8.0	9.5	0.6	F	2000	27	0.14	EEHAZK1E271B	1000
	470	10.0	9.5	0.6	G	2800	20	0.14	EEHAZK1E471B	500
35	180	8.0	9.5	0.6	F	2000	27	0.12	EEHAZK1V181B	1000
	330	10.0	9.5	0.6	G	2800	20	0.12	EEHAZK1V331B	500

*1: Ripple current (100 kHz / +125 °C)

*2: ESR (100 kHz / +20 °C)

*3: tan δ (120 Hz / +20 °C)

◆ Please refer to the page of "Flow soldering profile" and "The taping dimensions".

Frequency correction factor for ripple current

Frequency (f)	100 Hz ≤ f < 120 Hz	120 Hz ≤ f < 200 Hz	200 Hz ≤ f < 300 Hz	300 Hz ≤ f < 500 Hz
Correction factor	0.15	0.20	0.25	0.30
Frequency (f)	500 Hz ≤ f < 1 kHz	1 kHz ≤ f < 2 kHz	2 kHz ≤ f < 3 kHz	3 kHz ≤ f < 5 kHz
Correction factor	0.40	0.50	0.60	0.65
Frequency (f)	5 kHz ≤ f < 10 kHz	10 kHz ≤ f < 15 kHz	15 kHz ≤ f < 20 kHz	20 kHz ≤ f < 30 kHz
Correction factor	0.70	0.75	0.80	0.85
Frequency (f)	30 kHz ≤ f < 40 kHz	40 kHz ≤ f < 50 kHz	50 kHz ≤ f < 100 kHz	100 kHz ≤ f < 1000 kHz
Correction factor	0.85	0.85	0.90	1.00

**Conductive Polymer Hybrid Aluminum
Electrolytic Capacitors**
Radial Lead Type
ZKU-A series



Features

- Endurance : 4000 h at 125 °C (Large capacitance / High ripple current)
- Taping products for automatic insertion
- AEC-Q200 compliant
- RoHS compliant

Specifications

Size code	F	G
Category temp. range	-55 °C to +125 °C	
Rated voltage range	25 V to 35 V	
Nominal capacitance range	220 µF to 330 µF	390 µF to 560 µF
Capacitance tolerance	±20 % (120 Hz / +20°C)	
Leakage current	I ≤ 0.01 CV (µA), 2 minutes after reaching rated voltage, 20 °C *CV = (Capacitance in µF) x (Rated voltage in V)	
Dissipation factor (tan δ)	Please see the attached characteristics list	
Surge voltage (V)	Rated voltage × 1.25 (15 °C to 35 °C)	
Endurance	+125 °C ± 2 °C, 4000 h, apply the rated ripple current without exceeding the rated voltage.	
	Capacitance change	Within ±30% of the initial value
	Dissipation factor (tan δ)	≤ 200 % of the initial limit
	ESR	≤ 200 % of the initial limit
	Leakage current	Within the initial limit
Shelf life	After storage for 1000 hours at +125 °C ± 2 °C with no voltage applied and then being stabilized at +20 °C, capacitors shall meet the limits specified in endurance. (Capacitors are left at room temperature and humidity for 2 hours after the test. Then, apply the rated voltage for 30min with a series protection resistance of 1000 Ω ± 10 Ω. Measure electrical characteristics after discharging the capacitor.)	
	+85 °C ± 2 °C, 85 % to 90 %RH, 2000 h, rated voltage applied	
	Damp heat (Load)	
Resistance to soldering heat	After flow soldering and then being stabilized at +20 °C, capacitors shall meet the following limits.	
	Capacitance change	Within ±10% of the initial value
	Dissipation factor (tan δ)	Within the initial limit
	Leakage current	Within the initial limit

Marking

Example : 25 V 330 µF
Marking color : BLACK

Negative polarity marking (-)

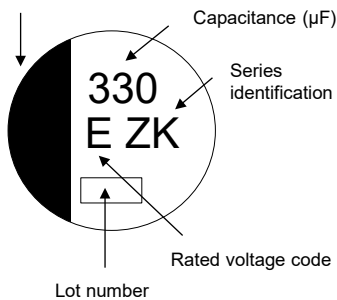

R.voltage code	Unit : V
E	25
V	35

Dimensions (not to scale)

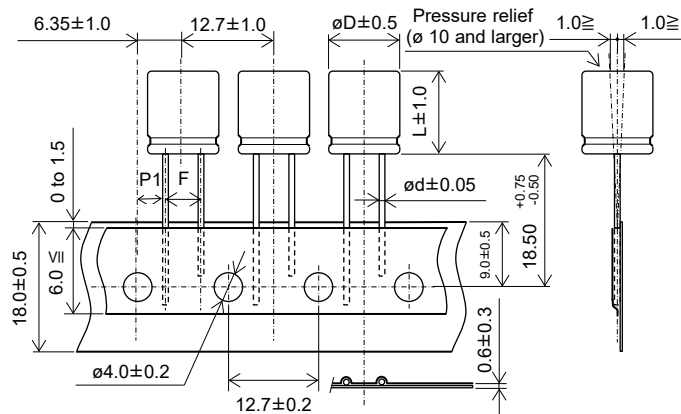

Size code	øD	L	ød	F	P1
F	8.0	9.5	0.6	3.5±0.5	4.60±0.50
G	10.0	9.5	0.6	5.0 ^{+0.8} _{-0.2}	3.85±0.50

Unit : mm

Explanation of part numbers

◆ Part number system e.g.: EEHAZKE331UB

EEHA	ZK		E		331		U	B		
Product classification	Series	Code	Rated voltage (V)	Code *	Capacitance (μF)	Code	Dia øD	Code	Lead space (mm)	Code
	ZKU	ZK	25	1E	220	221	Miniaturization product	U	3.5, 5.0	B
			35	1V	330	331				
					390	391				
					560	561				

*: If the total figures number of the part number exceeds 12 figures, "1" is omitted.

Characteristics list

Endurance : 125 °C 4000 h

Rated voltage (V)	Capacitance (±20 %) (μF)	Case size (mm)			Size code	Specification			Part number	Min. packaging q'ty (pcs)
		øD	L	ød		Ripple current ^{*1} (mA rms)	ESR ^{*2} (mΩ)	tan δ ^{*3}		Taping
25	330	8.0	9.5	0.6	F	2000	27	0.14	EEHAZKE331UB	1000
	560	10.0	9.5	0.6	G	2800	20	0.14	EEHAZKE561UB	500
35	220	8.0	9.5	0.6	F	2000	27	0.12	EEHAZKV221UB	1000
	390	10.0	9.5	0.6	G	2800	20	0.12	EEHAZKV391UB	500

*1: Ripple current (100 kHz / +125 °C)

*2: ESR (100 kHz / +20 °C)

*3: tan δ (120 Hz / +20 °C)

◆ Please refer to the page of "Flow soldering profile" and "The taping dimensions".

Frequency correction factor for ripple current

Frequency (f)	100 Hz ≤ f < 120 Hz	120 Hz ≤ f < 200 Hz	200 Hz ≤ f < 300 Hz	300 Hz ≤ f < 500 Hz
Correction factor	0.15	0.20	0.25	0.30
Frequency (f)	500 Hz ≤ f < 1 kHz	1 kHz ≤ f < 2 kHz	2 kHz ≤ f < 3 kHz	3 kHz ≤ f < 5 kHz
Correction factor	0.40	0.50	0.60	0.65
Frequency (f)	5 kHz ≤ f < 10 kHz	10 kHz ≤ f < 15 kHz	15 kHz ≤ f < 20 kHz	20 kHz ≤ f < 30 kHz
Correction factor	0.70	0.75	0.80	0.85
Frequency (f)	30 kHz ≤ f < 40 kHz	40 kHz ≤ f < 50 kHz	50 kHz ≤ f < 100 kHz	100 kHz ≤ f < 1000 kHz
Correction factor	0.85	0.85	0.90	1.00

**Conductive Polymer Hybrid Aluminum
Electrolytic Capacitors**
Radial Lead Type
ZT-A series

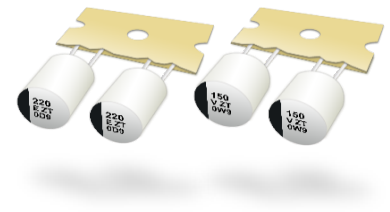

Features

- Endurance : 4000 h at 135 °C / 125 °C (High ripple current)
- Taping products for automatic insertion
- AEC-Q200 compliant
- RoHS compliant

Specifications

Size code	F		G	
Category temp. range	-55 °C to +135 °C			
Rated voltage range	25 V to 63 V			
Nominal capacitance range	33 μF to 220 μF		56 μF to 330 μF	
Capacitance tolerance	±20 % (120 Hz / +20°C)			
Leakage current	$I \leq 0.01 CV$ (μA) 2 minutes after reaching rated voltage, 20 °C *CV = (Capacitance in μF) x (Rated voltage in V)			
Dissipation factor (tan δ)	Please see the attached characteristics list			
Surge voltage (V)	Rated voltage × 1.25 (15 °C to 35 °C)			
Endurance 1	+125 °C ± 2 °C, 4000 h, apply the rated ripple current without exceeding the rated voltage.			
	Capacitance change	Within ±30% of the initial value		
	Dissipation factor (tan δ)	≤ 200 % of the initial limit		
	ESR	≤ 200 % of the initial limit		
	Leakage current	Within the initial limit		
Endurance 2	+135 °C ± 2 °C, 4000 h, apply the rated ripple current without exceeding the rated voltage.			
	Capacitance change	Within ±30% of the initial value		
	Dissipation factor (tan δ)	≤ 200 % of the initial limit		
	ESR	≤ 200 % of the initial limit		
	Leakage current	Within the initial limit		
Shelf life	After storage for 1000 hours at +135 °C ± 2 °C with no voltage applied and then being stabilized at +20 °C, capacitors shall meet the limits specified in endurance. (Capacitors are left at room temperature and humidity for 2 hours after the test. Then, apply the rated voltage for 30min with a series protection resistance of 1000 Ω ± 10 Ω. Measure electrical characteristics after discharging the capacitor.)			
	+85 °C ± 2 °C, 85 % to 90 %RH, 2000 h, rated voltage applied			
	Damp heat (Load)	After flow soldering and then being stabilized at +20 °C, capacitors shall meet the following limits.		
Resistance to soldering heat	Capacitance change	Within ±10% of the initial value		
	Dissipation factor (tan δ)	Within the initial limit		
	Leakage current	Within the initial limit		
	Leakage current	Within the initial limit		

Marking

Example : 25 V 220 μF
Marking color : BLACK

Negative polarity marking (-)

Capacitance (μF)

Series identification

Rated voltage code

Lot number

R.voltage code	Unit : V
E	25
V	35
H	50
J	63

Dimensions (not to scale)

Size code	øD	L	ød	F	P1
F	8.0	9.5	0.6	3.5±0.5	4.60±0.50
G	10.0	9.5	0.6	5.0 ±0.8	3.85±0.50

Unit : mm

Explanation of part numbers

◆ Part number system e.g.: EEHAZT1E221B

EEHA	ZT		1E		221		B			
Product classification	Series	Code	Rated voltage (V)	Code*	Capacitance (μF)	Code	Capacitance (μF)	Code	Lead space (mm)	Code
	ZT	ZT	25	1E	33	330	120	121	3.5, 5.0	B
			35	1V	47	470	150	151		
			50	1H	56	560	220	221		
			63	1J	68	680	270	271		
					82	820	330	331		
					100	101				

*: If the total figures number of the part number exceeds 12 figures, "1" is omitted.

Characteristics list

Endurance 1 : 125 °C 4000 h

Endurance 2 : 135 °C 4000 h

Rated voltage (V)	Capacitance (±20 %) (μF)	Case size (mm)			Size code	Specification				Part number	Min. packaging qty (pcs)
		øD	L	ød		Ripple current* ¹ (mA rms)		ESR* ² (mΩ)	tan δ* ³		
						Endurance 1 (+125 °C)	Endurance 2 (+135 °C)				
25	220	8.0	9.5	0.6	F	2900	1800	22	0.14	EEHAZT1E221B	1000
	330	10.0	9.5	0.6	G	3500	2200	16	0.14	EEHAZT1E331B	500
35	150	8.0	9.5	0.6	F	2900	1800	22	0.12	EEHAZT1V151B	1000
	270	10.0	9.5	0.6	G	3500	2200	16	0.12	EEHAZT1V271B	500
50	68	8.0	9.5	0.6	F	2700	1700	25	0.10	EEHAZT1H680B	1000
	100	10.0	9.5	0.6	G	2900	1800	23	0.10	EEHAZT1H101B	500
	120	10.0	9.5	0.6	G	2900	1800	23	0.10	EEHAZT1H121B	500
63	33	8.0	9.5	0.6	F	2400	1500	32	0.08	EEHAZT1J330B	1000
	47	8.0	9.5	0.6	F	2400	1500	32	0.08	EEHAZT1J470B	1000
	56	10.0	9.5	0.6	G	2800	1700	25	0.08	EEHAZT1J560B	500
	68	10.0	9.5	0.6	G	2800	1700	25	0.08	EEHAZT1J680B	500
	82	10.0	9.5	0.6	G	2800	1700	25	0.08	EEHAZT1J820B	500

*1: Ripple current (100 kHz / +125 °C or +135 °C)

*2: ESR (100 kHz / +20 °C)

*3: tan δ (120 Hz / +20 °C)

◆ Please refer to the page of "Flow soldering profile" and "The taping dimensions".

Frequency correction factor for ripple current

Rated capacitance (C)	Frequency (f)	100 Hz ≤ f < 200 Hz	200 Hz ≤ f < 300 Hz	300 Hz ≤ f < 500 Hz	500 Hz ≤ f < 1 kHz
C < 47 μF	Correction factor	0.10	0.10	0.15	0.20
47 μF ≤ C < 150 μF		0.15	0.20	0.25	0.30
150 μF ≤ C		0.15	0.25	0.25	0.30
Rated capacitance (C)	Frequency (f)	1 kHz ≤ f < 2 kHz	2 kHz ≤ f < 3 kHz	3 kHz ≤ f < 5 kHz	5 kHz ≤ f < 10 kHz
C < 47 μF	Correction factor	0.30	0.40	0.45	0.50
47 μF ≤ C < 150 μF		0.40	0.45	0.55	0.60
150 μF ≤ C		0.45	0.50	0.60	0.65
Rated capacitance (C)	Frequency (f)	10 kHz ≤ f < 15 kHz	15 kHz ≤ f < 20 kHz	20 kHz ≤ f < 30 kHz	30 kHz ≤ f < 40 kHz
C < 47 μF	Correction factor	0.60	0.65	0.70	0.75
47 μF ≤ C < 150 μF		0.70	0.75	0.80	0.80
150 μF ≤ C		0.75	0.80	0.85	0.85
Rated capacitance (C)	Frequency (f)	40 kHz ≤ f < 50 kHz	50 kHz ≤ f < 100 kHz	100 kHz ≤ f < 500 kHz	500 kHz ≤ f < 1000 kHz
C < 47 μF	Correction factor	0.80	0.85	1.00	1.05
47 μF ≤ C < 150 μF		0.85	0.90	1.00	1.00
150 μF ≤ C		0.85	0.90	1.00	1.00

Design and specifications are each subject to change without notice. Ask factory for the current technical specifications before purchase and/or use.
Should a safety concern arise regarding this product, please be sure to contact us immediately.

**Conductive Polymer Hybrid Aluminum
Electrolytic Capacitors**
Radial Lead Type
ZS-A series

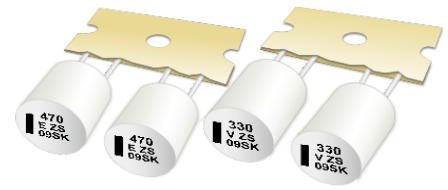

Features

- Endurance : 4000 h at 135 °C / 125 °C (Large capacitance / High ripple current / Low ESR)
- Taping products for automatic insertion
- AEC-Q200 compliant
- RoHS compliant

Specifications

Size code	G12		G16	
Category temp. range	-55 °C to +135 °C			
Rated voltage range	25 V to 63 V			
Nominal capacitance range	100 µF to 470 µF		150 µF to 560 µF	
Capacitance tolerance	±20 % (120 Hz / +20°C)			
Leakage current	$I \leq 0.01 CV (\mu A)$ 2 minutes after reaching rated voltage, 20 °C *CV = (Capacitance in µF) x (Rated voltage in V)			
Dissipation factor (tan δ)	Please see the attached characteristics list			
Surge voltage (V)	Rated voltage × 1.25 (15 °C to 35 °C)			
Endurance 1	+125 °C ± 2 °C, 4000 h, apply the rated ripple current without exceeding the rated voltage.			
	Capacitance change	Within ±30% of the initial value		
	Dissipation factor (tan δ)	≤ 200 % of the initial limit		
	ESR	≤ 200 % of the initial limit		
Endurance 2	+135 °C ± 2 °C, 4000 h, apply the rated ripple current without exceeding the rated voltage.			
	Capacitance change	Within ±30% of the initial value		
	Dissipation factor (tan δ)	≤ 200 % of the initial limit		
	ESR	≤ 200 % of the initial limit		
Shelf life	After storage for 1000 hours at +135 °C ± 2 °C with no voltage applied and then being stabilized at +20 °C, capacitors shall meet the limits specified in endurance. (Capacitors are left at room temperature and humidity for 2 hours after the test. Then, apply the rated voltage for 30min with a series protection resistance of 1000 Ω ± 10 Ω. Measure electrical characteristics after discharging the capacitor.)			
	+85 °C ± 2 °C, 85 % to 90 %RH, 2000 h, rated voltage applied			
Damp heat (Load)	+85 °C ± 2 °C, 85 % to 90 %RH, 2000 h, rated voltage applied			
	Capacitance change	Within ±30% of the initial value		
	Dissipation factor (tan δ)	≤ 200 % of the initial limit		
	ESR	≤ 200 % of the initial limit		
Resistance to soldering heat	After flow soldering and then being stabilized at +20 °C, capacitors shall meet the following limits.			
	Capacitance change	Within ±10% of the initial value		
	Dissipation factor (tan δ)	Within the initial limit		
	Leakage current	Within the initial limit		

Marking

Example : 25 V 470 µF
Marking color : BLACK

Negative polarity marking (-)

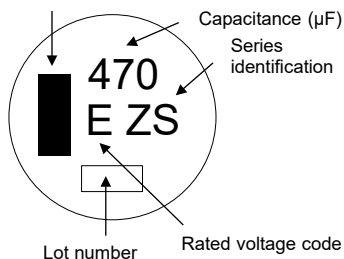

R.voltage code	Unit : V
E	25
V	35
H	50
J	63

Dimensions (not to scale)

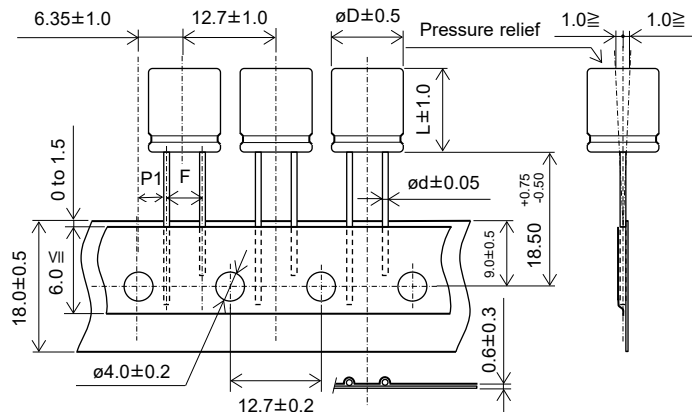

Size code	øD	L	ød	F	P1	Unit : mm
G12	10.0	11.7	0.8	5.0 ^{+0.8} _{-0.2}	3.85±0.50	
G16	10.0	15.7	0.8	5.0 ^{+0.8} _{-0.2}	3.85±0.50	

Explanation of part numbers

◆ Part number system e.g.: EEHAZS1E471B

EEHA	ZS		1E		471				B	
Product classification	Series	Code	Rated voltage (V)	Code*	Capacitance (μF)	Code	Capacitance (μF)	Code	Lead space (mm)	Code
	ZS	ZS	25	1E	100	101	330	331	3.5, 5.0	B
			35	1V	150	151	470	471		
			50	1H	220	221	560	561		
			63	1J						

*: If the total figures number of the part number exceeds 12 figures, "1" is omitted.

Characteristics list

Endurance 1 : 125 °C 4000 h
Endurance 2 : 135 °C 4000 h

Rated voltage (V)	Capacitance (±20 %) (μF)	Case size (mm)			Size code	Specification				Part number	Min. packaging q'ty (pcs)
		øD	L	ød		Ripple current* ¹ (mA rms)		ESR* ² (mΩ)	tan δ* ³		Taping
						Endurance 1 (+125°C)	Endurance 2 (+135°C)				
25	470	10.0	11.7	0.8	G12	3500	2500	14	0.14	EEHAZS1E471B	500
	560	10.0	15.7	0.8	G16	4000	2900	11	0.14	EEHAZS1E561B	500
35	330	10.0	11.7	0.8	G12	3500	2500	14	0.12	EEHAZS1V331B	500
	470	10.0	15.7	0.8	G16	4000	2900	11	0.12	EEHAZS1V471B	500
50	150	10.0	11.7	0.8	G12	3200	2250	17	0.10	EEHAZS1H151B	500
	220	10.0	15.7	0.8	G16	3700	2600	13	0.10	EEHAZS1H221B	500
63	100	10.0	11.7	0.8	G12	3000	2100	19	0.08	EEHAZS1J101B	500
	150	10.0	15.7	0.8	G16	3500	2400	15	0.08	EEHAZS1J151B	500

*1: Ripple current (100 kHz / +125 °C or +135 °C)

*2: ESR (100 kHz / +20 °C)

*3: tan δ (120 Hz / +20 °C)

◆ Please refer to the page of "Flow soldering profile" and "The taping dimensions".

Frequency correction factor for ripple current

Rated capacitance (C)	Frequency (f)	100 Hz ≤ f < 200 Hz	200 Hz ≤ f < 300 Hz	300 Hz ≤ f < 500 Hz	500 Hz ≤ f < 1 kHz
100 μF ≤ C < 150 μF	Correction factor	0.15	0.20	0.25	0.30
	150 μF ≤ C	0.15	0.25	0.25	0.30
100 μF ≤ C < 150 μF	Correction factor	0.40	0.45	0.55	0.60
	150 μF ≤ C	0.45	0.50	0.60	0.65
100 μF ≤ C < 150 μF	Correction factor	0.70	0.75	0.80	0.80
	150 μF ≤ C	0.75	0.80	0.85	0.85
100 μF ≤ C < 150 μF	Correction factor	0.85	0.90	1.00	1.00
	150 μF ≤ C	0.85	0.90	1.00	1.00

**Conductive Polymer Hybrid Aluminum
Electrolytic Capacitors**
Radial Lead Type
ZSU-A series

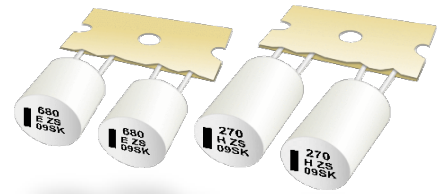

Features

- Endurance : 4000 h at 135 °C / 125 °C
- Large capacitance compared with ZS series
- Taping products for automatic insertion
- AEC-Q200 compliant
- RoHS compliant

Specifications

Size code	G12		G16	
Category temp. range	-55 °C to +135 °C			
Rated voltage range	25 V to 63 V			
Nominal capacitance range	120 μF to 680 μF		180 μF to 1000 μF	
Capacitance tolerance	±20 % (120 Hz / +20°C)			
Leakage current	I ≤ 0.01 CV (μA), 2 minutes after reaching rated voltage, 20 °C *CV = (Capacitance in μF) x (Rated voltage in V)			
Dissipation factor (tan δ)	Please see the attached characteristics list			
Surge voltage (V)	Rated voltage × 1.25 (15 °C to 35 °C)			
Endurance 1	+125 °C ± 2 °C, 4000 h, apply the rated ripple current without exceeding the rated voltage.			
	Capacitance change	Within ±30% of the initial value		
	Dissipation factor (tan δ)	≤ 200 % of the initial limit		
	ESR	≤ 200 % of the initial limit		
	Leakage current	Within the initial limit		
Endurance 2	+135 °C ± 2 °C, 4000 h, apply the rated ripple current without exceeding the rated voltage.			
	Capacitance change	Within ±30% of the initial value		
	Dissipation factor (tan δ)	≤ 200 % of the initial limit		
	ESR	≤ 200 % of the initial limit		
	Leakage current	Within the initial limit		
Shelf life	After storage for 1000 hours at +135 °C ± 2 °C with no voltage applied and then being stabilized at +20 °C, capacitors shall meet the limits specified in endurance. (Capacitors are left at room temperature and humidity for 2 hours after the test. Then, apply the rated voltage for 30min with a series protection resistance of 1000 Ω ± 10 Ω. Measure electrical characteristics after discharging the capacitor.)			
	+85 °C ± 2 °C, 85 % to 90 %RH, 2000 h, rated voltage applied			
	Capacitance change	Within ±30% of the initial value		
Damp heat (Load)	Dissipation factor (tan δ)	≤ 200 % of the initial limit		
	ESR	≤ 200 % of the initial limit		
	Leakage current	Within the initial limit		
	Resistance to soldering heat	After flow soldering and then being stabilized at +20 °C, capacitors shall meet the following limits.		
Resistance to soldering heat	Capacitance change	Within ±10% of the initial value		
	Dissipation factor (tan δ)	Within the initial limit		
	Leakage current	Within the initial limit		

Marking

Example : 25 V 680 μF
Marking color : BLACK

Negative polarity marking (-)

Capacitance (μF)
Series identification
Rated voltage code

R.voltage code	Unit : V
E	25
V	35
H	50
J	63

Dimensions (not to scale)

Size code	øD	L	ød	F	P1
G12	10.0	11.7	0.8	5.0 ^{+0.8} _{-0.2}	3.85±0.50
G16	10.0	15.7	0.8	5.0 ^{+0.8} _{-0.2}	3.85±0.50

Unit : mm

Explanation of part numbers

◆ Part number system e.g.: EEHAZSE681UB

EEHA	ZS		E		681		U		B	
Product classification	Series	Code	Rated voltage (V)	Code *	Capacitance (μF)	Code	Dia øD	Code	Lead space (mm)	Code
	ZSU	ZS	25	1E	120	121	Miniaturization product	U	3.5, 5.0	B
			35	1V	180	181				
			50	1H	270	271				
			63	1J	470	471				
					680	681				
					1000	102				

*: If the total figures number of the part number exceeds 12 figures, "1" is omitted.

Characteristics list

Endurance 1 : 125 °C 4000 h

Endurance 2 : 135 °C 4000 h

Rated voltage (V)	Capacitance (±20 %) (μF)	Case size (mm)			Size code	Specification				Part number	Min. packaging q'ty (pcs)
		øD	L	ød		Ripple current* ¹ (mA rms)		ESR* ² (mΩ)	tan δ* ³		Taping
						Endurance 1 (+125 °C)	Endurance 2 (+135 °C)				
25	680	10.0	11.7	0.8	G12	3500	2500	14	0.14	EEHAZSE681UB	500
	1000	10.0	15.7	0.8	G16	4000	2900	11	0.14	EEHAZSE102UB	500
35	470	10.0	11.7	0.8	G12	3500	2500	14	0.12	EEHAZSV471UB	500
	680	10.0	15.7	0.8	G16	4000	2900	11	0.12	EEHAZSV681UB	500
50	180	10.0	11.7	0.8	G12	3200	2250	17	0.10	EEHAZSH181UB	500
	270	10.0	15.7	0.8	G16	3700	2600	13	0.10	EEHAZSH271UB	500
63	120	10.0	11.7	0.8	G12	3000	2100	19	0.08	EEHAZSJ121UB	500
	180	10.0	15.7	0.8	G16	3500	2400	15	0.08	EEHAZSJ181UB	500

*1: Ripple current (100 kHz / +125 °C or +135 °C)

*2: ESR (100 kHz / +20 °C)

*3: tan δ (120 Hz / +20 °C)

◆ Please refer to the page of "Flow soldering profile" and "The taping dimensions".

Frequency correction factor for ripple current

Rated capacitance (C)	Frequency (f)	100 Hz ≤ f < 120 Hz	120 Hz ≤ f < 200 Hz	200 Hz ≤ f < 300 Hz	300 Hz ≤ f < 500 Hz
120 μF ≤ C	Correction factor	0.15	0.20	0.25	0.30

Rated capacitance (C)	Frequency (f)	500 Hz ≤ f < 1 kHz	1 kHz ≤ f < 2 kHz	2 kHz ≤ f < 3 kHz	3 kHz ≤ f < 5 kHz
120 μF ≤ C	Correction factor	0.40	0.50	0.60	0.65

Rated capacitance (C)	Frequency (f)	5 kHz ≤ f < 10 kHz	10 kHz ≤ f < 15 kHz	15 kHz ≤ f < 20 kHz	20 kHz ≤ f < 30 kHz
120 μF ≤ C	Correction factor	0.70	0.75	0.80	0.85

Rated capacitance (C)	Frequency (f)	30 kHz ≤ f < 50 kHz	50 kHz ≤ f < 100 kHz	100 kHz ≤ f < 500 kHz	500 kHz ≤ f < 1000 kHz
120 μF ≤ C	Correction factor	0.85	0.90	1.00	1.00

**Conductive Polymer Hybrid Aluminum
Electrolytic Capacitors**
Radial Lead Type
ZE-A series



Features

- Endurance : 2000 h at 145 °C (High temperature / Long life)
- Taping products for automatic insertion
- AEC-Q200 compliant
- RoHS compliant

Specifications

Size code	F	G
Category temp. range	-55 °C to +145 °C	
Rated voltage range	25 V to 63 V	
Nominal capacitance range	33 µF to 220 µF	56 µF to 330 µF
Capacitance tolerance	±20 % (120 Hz / +20°C)	
Leakage current	I ≤ 0.01 CV (µA), 2 minutes after reaching rated voltage, 20 °C *CV = (Capacitance in µF) x (Rated voltage in V)	
Dissipation factor (tan δ)	Please see the attached characteristics list	
Surge voltage (V)	Rated voltage × 1.25 (15 °C to 35 °C)	
Endurance 1	+145 °C ± 2 °C, 2000 h, apply the rated ripple current without exceeding the rated voltage.	
	Capacitance change	Within ±30% of the initial value
	Dissipation factor (tan δ)	≤ 200 % of the initial limit
	ESR	≤ 200 % of the initial limit
Endurance 2	+135 °C ± 2 °C, 4000 h, apply the rated ripple current without exceeding the rated voltage.	
	Capacitance change	Within ±30% of the initial value
	Dissipation factor (tan δ)	≤ 200 % of the initial limit
	ESR	≤ 300 % of the initial limit
Shelf life	After storage for 1000 hours at +145 °C ± 2 °C with no voltage applied and then being stabilized at +20 °C, capacitors shall meet the limits specified in endurance. (Capacitors are left at room temperature and humidity for 2 hours after the test. Then, apply the rated voltage for 30min with a series protection resistance of 1000 Ω ± 10 Ω. Measure electrical characteristics after discharging the capacitor.)	
	+85 °C ± 2 °C, 85 % to 90 %RH, 2000 h, rated voltage applied	
Damp heat (Load)	Capacitance change	
	Dissipation factor (tan δ)	
	ESR	
	Leakage current	
Resistance to soldering heat	After flow soldering and then being stabilized at +20 °C, capacitors shall meet the following limits.	
	Capacitance change	
	Dissipation factor (tan δ)	
	Leakage current	

Marking

Example : 25 V 220 µF
Marking color : BLACK

Negative polarity marking (-)

Capacitance (µF)

Series identification

Rated voltage code

Lot number

R.voltage code	Unit : V
E	25
V	35
H	50
J	63

Dimensions (not to scale)

Size code	øD	L	ød	F	P1
F	8.0	9.5	0.6	3.5±0.5	4.60±0.50
G	10.0	9.5	0.6	5.0 ±0.2	3.85±0.50

Unit : mm

Explanation of part numbers

◆ Part number system e.g.: EEHAZE1E221B

EEHA	ZE		1E		221		B			
Product classification	Series	Code	Rated voltage (V)	Code*	Capacitance (μF)	Code	Capacitance (μF)	Code	Lead space (mm)	Code
	ZE	ZE	25	1E	33	330	150	151	3.5, 5.0	B
			35	1V	56	560	220	221		
			50	1H	68	680	270	271		
			63	1J	82	820	330	331		
					100	101				

*: If the total figures number of the part number exceeds 12 figures, "1" is omitted.

Characteristics list

Endurance 1 : 145 °C 2000 h

Endurance 2 : 135 °C 4000 h

Rated voltage (V)	Capacitance (±20 %) (μF)	Case size (mm)			Size code	Specification				Part number	Min. packaging q'ty (pcs)
		øD	L	ød		Ripple current*1 (mA rms)		ESR*2 (mΩ)	tan δ*3		Taping
						Endurance 1 (+145 °C)	Endurance 2 (+135 °C)				
25	220	8.0	9.5	0.6	F	700	1600	27	0.14	EEHAZE1E221B	1000
	330	10.0	9.5	0.6	G	900	2000	20	0.14	EEHAZE1E331B	500
35	150	8.0	9.5	0.6	F	700	1600	27	0.12	EEHAZE1V151B	1000
	270	10.0	9.5	0.6	G	900	2000	20	0.12	EEHAZE1V271B	500
50	68	8.0	9.5	0.6	F	600	1250	30	0.10	EEHAZE1H680B	1000
	100	10.0	9.5	0.6	G	800	1600	28	0.10	EEHAZE1H101B	500
63	33	8.0	9.5	0.6	F	600	1100	40	0.08	EEHAZE1J330B	1000
	56	10.0	9.5	0.6	G	800	1400	30	0.08	EEHAZE1J560B	500
	82	10.0	9.5	0.6	G	800	1400	30	0.08	EEHAZE1J820B	500

*1: Ripple current (100 kHz / +145 °C or +135 °C)

*2: ESR (100 kHz / +20 °C)

*3: tan δ (120 Hz / +20 °C)

◆ Please refer to the page of "Flow soldering profile" and "The taping dimensions".

Frequency correction factor for ripple current

Rated capacitance (C)	Frequency (f)	100 Hz ≤ f < 200 Hz	200 Hz ≤ f < 300 Hz	300 Hz ≤ f < 500 Hz	500 Hz ≤ f < 1 kHz
C < 47 μF	Correction factor	0.10	0.10	0.15	0.20
47 μF ≤ C < 150 μF		0.15	0.20	0.25	0.30
150 μF ≤ C		0.15	0.25	0.25	0.30
Rated capacitance (C)	Frequency (f)	1 kHz ≤ f < 2 kHz	2 kHz ≤ f < 3 kHz	3 kHz ≤ f < 5 kHz	5 kHz ≤ f < 10 kHz
C < 47 μF	Correction factor	0.30	0.40	0.45	0.50
47 μF ≤ C < 150 μF		0.40	0.45	0.55	0.60
150 μF ≤ C		0.45	0.50	0.60	0.65
Rated capacitance (C)	Frequency (f)	10 kHz ≤ f < 15 kHz	15 kHz ≤ f < 20 kHz	20 kHz ≤ f < 30 kHz	30 kHz ≤ f < 40 kHz
C < 47 μF	Correction factor	0.60	0.65	0.70	0.75
47 μF ≤ C < 150 μF		0.70	0.75	0.80	0.80
150 μF ≤ C		0.75	0.80	0.85	0.85
Rated capacitance (C)	Frequency (f)	40 kHz ≤ f < 50 kHz	50 kHz ≤ f < 100 kHz	100 kHz ≤ f < 500 kHz	500 kHz ≤ f < 1000 kHz
C < 47 μF	Correction factor	0.80	0.85	1.00	1.05
47 μF ≤ C < 150 μF		0.85	0.90	1.00	1.00
150 μF ≤ C		0.85	0.90	1.00	1.00

After endurance ESR (100 kHz, -40 °C)

Size code	F (ø8 x L9.5)	G (ø10 x L9.5)
ESR (Ω)	0.4	0.3

**Conductive Polymer Hybrid Aluminum
Electrolytic Capacitors**
Radial Lead Type
ZF-A series

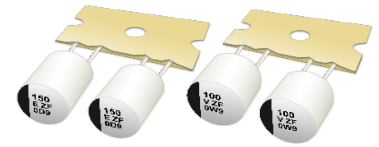

Features

- Endurance : 1000 h at 150 °C (High temperature)
- High temperature compared with ZC series
- High-withstand voltage (to 63 V)
- Characteristics dependencies in frequency and low temperature are as small as polymer type
- Compatible with taping products for automatic insertion
- AEC-Q200 compliant
- RoHS compliant

Specifications

Size code	F	G
Category temp. range	-55 °C to +150 °C	
Rated voltage range	25 V to 63 V	
Nominal capacitance range	33 µF to 150 µF	56 µF to 270 µF
Capacitance tolerance	±20 % (120 Hz / +20°C)	
Leakage current	I ≤ 0.01 CV (µA), 2 minutes after reaching rated voltage, 20 °C *CV = (Capacitance in µF) x (Rated voltage in V)	
Dissipation factor (tan δ)	Please see the attached characteristics list	
Surge voltage (V)	Rated voltage × 1.25 (15 °C to 35 °C)	
Endurance	+150 °C ± 2 °C, 1000 h, apply the rated ripple current without exceeding the rated voltage.	
	Capacitance change	Within ±30% of the initial value
	Dissipation factor (tan δ)	≤ 200 % of the initial limit
	ESR	≤ 200 % of the initial limit
	Leakage current	Within the initial limit
ESR after endurance (Ω / 100 kHz)(-40 °C)	Size code	
	F	G
Shelf life	After storage for 1000 hours at +150 °C ± 2 °C with no voltage applied and then being stabilized at +20 °C, capacitors shall meet the limits specified in endurance. (Capacitors are left at room temperature and humidity for 2 hours after the test. Then, apply the rated voltage for 30min with a series protection resistance of 1000 Ω ± 10 Ω. Measure electrical characteristics after discharging the capacitor.)	
	+85 °C ± 2 °C, 85 % to 90 %RH, 2000 h, rated voltage applied	
Damp heat (Load)	Capacitance change	Within ±30% of the initial value
	Dissipation factor (tan δ)	≤ 200 % of the initial limit
	ESR	≤ 200 % of the initial limit
	Leakage current	Within the initial limit
Resistance to soldering heat	After flow soldering and then being stabilized at +20 °C, capacitors shall meet the following limits.	
	Capacitance change	Within ±10% of the initial value
	Dissipation factor (tan δ)	Within the initial limit
	Leakage current	Within the initial limit

Marking

Example : 25 V 150 µF
Marking color : BLACK

Negative polarity marking (-)
Capacitance (µF)
Series identification
Rated voltage code
Lot number

R. voltage code	Unit : V
E	25
V	35
H	50
J	63

Dimensions (not to scale)

Size code	øD	L	ød	F	P1
F	8.0	9.5	0.6	3.5±0.5	4.60±0.50
G	10.0	9.5	0.6	5.0 ^{+0.8} _{-0.5}	3.85±0.50

Unit : mm

Explanation of part numbers

◆ Part number system e.g.: EEHAZF1E151B

EEHA	ZF		1E		151		B			
Product classification	Series	Code	Rated voltage (V)	Code*	Capacitance (μF)	Code	Capacitance (μF)	Code	Lead space (mm)	Code
	ZF	ZF	25	1E	33	330	150	151	3.5, 5.0	B
			35	1V	56	560	270	271		
			50	1H	100	101				
			63	1J						

*: If the total figures number of the part number exceeds 12 figures, "1" is omitted.

Characteristics list

Endurance : 150 °C 1000 h

Rated voltage (V)	Capacitance (±20 %) (μF)	Case size (mm)			Size code	Specification			Part number	Min. packaging q'ty (pcs)
		øD	L	ød		Ripple current ^{*1} (mA rms)	ESR ^{*2} (mΩ)	tan δ ^{*3}		Taping
25	150	8.0	9.5	0.6	F	800	27	0.14	EEHAZF1E151B	1000
	270	10.0	9.5	0.6	G	1000	20	0.14	EEHAZF1E271B	500
35	100	8.0	9.5	0.6	F	770	30	0.12	EEHAZF1V101B	1000
	150	10.0	9.5	0.6	G	950	23	0.12	EEHAZF1V151B	500
50	56	8.0	9.5	0.6	F	700	35	0.10	EEHAZF1H560B	1000
	100	10.0	9.5	0.6	G	900	28	0.10	EEHAZF1H101B	500
63	33	8.0	9.5	0.6	F	650	40	0.08	EEHAZF1J330B	1000
	56	10.0	9.5	0.6	G	840	30	0.08	EEHAZF1J560B	500

*1: Ripple current (100 kHz / +150 °C)

*2: ESR (100 kHz / +20 °C)

*3: tan δ (120 Hz / +20 °C)

◆ Please refer to the page of "Flow soldering profile" and "The taping dimensions".

Frequency correction factor for ripple current

Rated capacitance (C)	Frequency (f)	100 Hz ≤ f < 200 Hz	200 Hz ≤ f < 300 Hz	300 Hz ≤ f < 500 Hz	500 Hz ≤ f < 1 kHz
C < 47 μF	Correction factor	0.10	0.10	0.15	0.20
47 μF ≤ C < 150 μF		0.15	0.20	0.25	0.30
150 μF ≤ C		0.15	0.25	0.25	0.30
Rated capacitance (C)	Frequency (f)	1 kHz ≤ f < 2 kHz	2 kHz ≤ f < 3 kHz	3 kHz ≤ f < 5 kHz	5 kHz ≤ f < 10 kHz
C < 47 μF	Correction factor	0.30	0.40	0.45	0.50
47 μF ≤ C < 150 μF		0.40	0.45	0.55	0.60
150 μF ≤ C		0.45	0.50	0.60	0.65
Rated capacitance (C)	Frequency (f)	10 kHz ≤ f < 15 kHz	15 kHz ≤ f < 20 kHz	20 kHz ≤ f < 30 kHz	30 kHz ≤ f < 40 kHz
C < 47 μF	Correction factor	0.60	0.65	0.70	0.75
47 μF ≤ C < 150 μF		0.70	0.75	0.80	0.80
150 μF ≤ C		0.75	0.80	0.85	0.85
Rated capacitance (C)	Frequency (f)	40 kHz ≤ f < 50 kHz	50 kHz ≤ f < 100 kHz	100 kHz ≤ f < 500 kHz	500 kHz ≤ f
C < 47 μF	Correction factor	0.80	0.85	1.00	1.05
47 μF ≤ C < 150 μF		0.85	0.90	1.00	1.00
150 μF ≤ C		0.85	0.90	1.00	1.00

Safety Precautions

When using our products, no matter what sort of equipment they might be used for, be sure to confirm the applications and environmental conditions with our specifications in advance.

Panasonic
INDUSTRY

Panasonic Industry Co., Ltd.
Device Solutions Business Division

1006 Kadoma, Kadoma City, Osaka
571-8506 Japan