

PennEngineering®

SELF-CLINCHING STUDS AND PINS

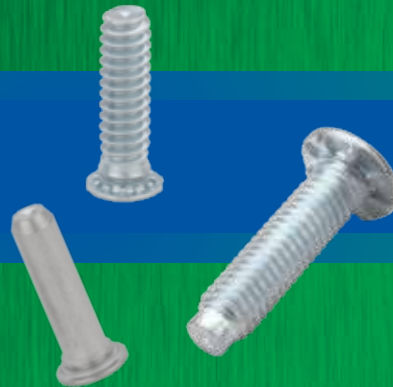

BULLETIN













FH



1113
REV 614

SELF-CLINCHING STUDS AND PINS

PEM® self-clinching studs are installed by placing them in properly sized holes in the sheets and squeezing into place with any standard press. The squeezing action embeds the head of the stud into the sheet. The metal displaced by the head flows smoothly and evenly around the ribs and into the annular groove – securely locking the stud into the sheet with high torque-out and pushout resistances.

Dog Point and Anti Cross-Thread Options - PAGE 4		HFE™ (heavy-duty) Studs Provides maximum pull through in sheets as thin as .040" / 1 mm - PAGE 10	
FH/FHS/FHA (flush-head) Studs are available in aluminum, steel, or stainless steel - PAGE 5		HFG8™/HF109™ (heavy-duty high tensile strength) Studs are manufactured for the most demanding applications from medium carbon alloy steel, then heat-treated to high strength and hardness qualities - PAGE 11	
FH4™/FHP™ (flush-head) Studs for Stainless Steel are designed to provide strong threads in stainless steel sheets as thin as .040" / 1 mm. Type FHP studs have high corrosion resistance - PAGE 6		FH/FHS/FHA (flush-head) Pins are available on special order - PAGE 12	
FHL™/FHLS™ (flush, low-displacement head) Studs install closer to the edge of a sheet than PEM Types FH/FHS studs - PAGE 7		SGPC™ Swaging Collar Studs can install into most panel material and accommodate multiple panels as long as the total thickness does not exceed the maximum sheet thickness - PAGE 13	
TFH/TFHS (non-flush) Studs are for sheets as thin as .020" / 0.51 mm. The stud head will not be flush but will project above the sheet surface approximately .025" / 0.64 mm - PAGE 8		TPS™/TP4™/TPXS™ (flush-head) Pilot Pins satisfy a wide range of positioning, pivot, and alignment applications - PAGE 14	
HFH/HFHS (heavy-duty) Studs have a large head which projects above the sheet material to distribute the axial tightening force over a large area thereby improving pull through resistance - PAGE 9		Material and finish specifications - PAGE 15	
HFHB (heavy-duty BUSBAR®) Studs are ideal for applications which demand superior electrical/mechanical attachment points - PAGE 9		Installation - PAGES 16 - 22	
Performance data - PAGES 23 - 28			

PAGE 5



Flush-head studs
Types FH/FHA/FHS/FHP/FH4

PAGE 7



Flush, low-displacement head studs
Types FHL/FHLS

PAGE 8



Thin sheet studs
Types TFH/TFHS

PAGE 9



Heavy-duty studs
Types HFH/HFHS/HFHB



SELF-CLINCHING STUDS AND PINS

STUD SELECTOR GUIDE

PEM Stud Type	Page No.	Application Requires:										
		Flush-head	Heavy Duty	Grade 8/ Property Class 10.9 Thread Strength	Sheet thickness as thin as .020"/ 0.51 mm	Superior electrical conductivity	Installation into stainless steel sheets	Compatibility with aluminum anodizing	Superior corrosion resistance	Closest centerline-to-edge distance	Unthreaded stud/pin	Large Hole in Attached Panel
FH	5	•										
FHA	5	•						•	•			
FHS	5	•							•			
FH4	6	•					•					
FHP	6	•					•		•			
FHL	7	•								•		
FHLS	7	•							•	•		
TFH	8				•							
TFHS	8				•				•			
HFH	9		• (1)									•
HFHB	9		•			•			•			•
HFHS	9		•						•			•
HFE	10		•									•
HFG8/HF109	11		•	•								•
FH Unthreaded	12	•									•	
FHA Unthreaded	12	•						•	•		•	
FHS Unthreaded	12	•							•		•	
SGPC	13						•			•		
TPS	14	•							•		•	
TP4	14	•					•				•	
TPXS	14	•							•		•	

(1) Meets grade 5 / property class 9.8 tensile requirements.

Standard product features shown above. Studs can also be custom designed to meet your exact application requirements.

PAGE 10



Heavy-duty studs for thin sheets
Type HFE

PAGE 11



Heavy-duty, high tensile strength studs
Types HFG8/HF109

PAGE 13



Swaging collar studs
Type SGPC

PAGE 14



Flush-head pins
Types TPS/TP4



SELF-CLINCHING STUDS AND PINS

OPTIONAL DOG POINT FEATURE

PEM® dog point lead-in option for studs allows quick location of the mating fastener during assembly and protects the first thread of the stud during nut engagement. This feature is available on Types FH, FHL, HFH, HFE, HF109, HFG8 and TFH studs.

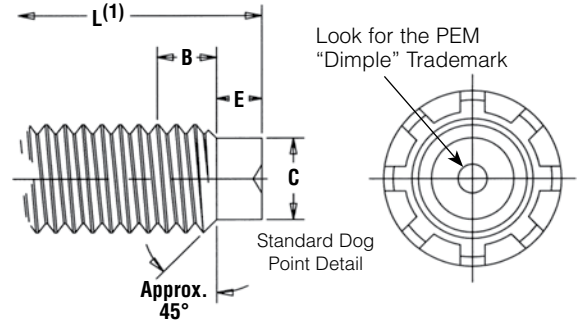

All dimensions are in inches.

UNIFIED	Thread Size	C ±.005 (2)	E ±.010	B Nom. Transitional Length to Full Thread
	.138-32 (#6-32)	.086	.050	.098
	.164-32 (#8-32)	.111	.055	.099
	.190-24 (#10-24)	.124	.065	.127
	.190-32 (#10-32)	.138	.065	.098
	.250-20 (1/4-20)	.173	.085	.149
	.250-28 (1/4-28)	.192	.085	.110
	.313-18 (5/16-18)	.228	.105	.164
	.313-24 (5/16-24)	.246	.105	.127
	.375-16 (3/8-16)	.282	.125	.182
.375-24 (3/8-24)	.309	.125	.126	

All dimensions are in millimeters.

METRIC	Thread Size x Pitch	C ±0.13 (2)	E ±0.25	B Nom. Transitional Length to Full Thread
	M3.5 x 0.6	2.4	1.27	1.88
	M4 x 0.7	2.79	1.4	2.26
	M5 x 0.8	3.66	1.78	2.48
	M6 x 1	4.37	2.03	3.05
	M8 x 1.25	6.05	2.67	3.73
	M10 x 1.5	7.72	3.43	4.37

OPTIONAL PART NUMBER DESIGNATION

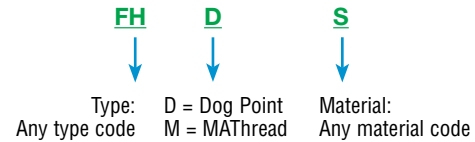

(1) For "L" refer to type stud lengths.

(2) Maximum dog point diameter is .003" / 0.08 mm less than minimum minor diameter of 2B or 6H nut threads.

OPTIONAL MAThread® ANTI CROSS-THREAD FEATURE

PennEngineering is a licensee of MAThread® Anti Cross-Threading Technology. This unique design allows the threads to self-align and drive easily with reduced effort. This helps speed assembly, reduce or eliminate failures, repairs, scrap, downtime, and warranty service associated with thread damage. This option is available on most types of PEM studs.

Here's how it works:



Anti Cross-Thread Feature

Misaligned Axis

The anti cross-threading design offers users the benefit of self-aligning, anti cross-threading threads.

Threads Cam

As the threads come into contact, the patented anti cross-thread begins to cam over the female thread.

Threads Drive Normally

The anti cross-threads promote alignment of the two thread helixes. The fasteners drive easily with reduced effort.

MAThread is a registered trademark of MAThread inc.

OPTIONAL THREAD MASK

PEM® Blu-Coat™ thread mask is available for applications where hardware is installed prior to painting. During assembly, the threads of the mating hardware will remove paint, electro deposited automotive under coatings, and weld spatter upon application of torque. PEM studs can be specially ordered with thread mask applied.



"BC" suffix will be added to part number to designate Blu-Coat thread mask to fastener.



SELF-CLINCHING STUDS AND PINS

TYPES FH/FHS/FHA FLUSH-HEAD STUDS

- Flush-head for sheet thickness of .040"/1 mm and greater.
- Type FH is recommended for use in steel or aluminum sheets HRB (Rockwell "B" scale) 80 or less and HB (Hardness Brinell) 150 or less.
- Type FHS is recommended for use in steel or aluminum sheets HRB (Rockwell "B" scale) 70 or less and HB (Hardness Brinell) 125 or less.
- Type FHA is recommended for use in aluminum sheets HRB (Rockwell "B" scale) 50 or less and HB (Hardness Brinell) 82 or less.

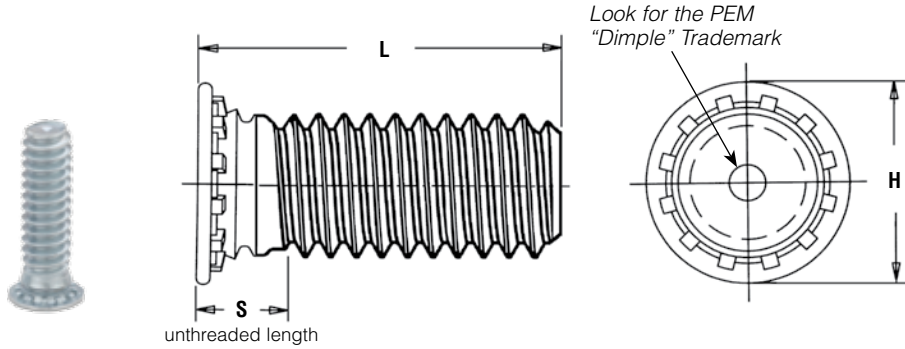

PART NUMBER DESIGNATION

FH	-	632	-	6	ZI
FH	S	- 632	-	6	
FH	A	- 632	-	6	
↓	↓	↓	↓	↓	↓
Type	Material Code	Thread Size Code	Length Code	Finish Code	

All dimensions are in inches.

UNIFIED	Thread Size	Type			Thread Code	Length Code "L" ±.015 (Length Code in 16ths of an inch)										Min. Sheet Thickness (1)	Hole Size in Sheet +.003 - .000	Max. Hole in Attach. Parts	H ± .015	S Max. (2)	Min. Dist. Hole ⌀ to Edge
		Fastener Material				.250	.312	.375	.500	.625	.750	.875	1.00	1.25	1.50						
		Steel	Stainless Steel	Aluminum																	
.086-56 (#2-56)	FH	FHS	—	256	4	5	6	8	10	12	—	—	—	—	.040	.085	.105	.144	.075	.187	
.112-40 (#4-40)	FH	FHS	FHA	440	4	5	6	8	10	12	14	16	20	—	.040	.111	.135	.176	.085	.219	
.138-32 (#6-32)	FH	FHS	FHA	632	4	5	6	8	10	12	14	16	20	24	.040	.137	.160	.206	.090	.250	
.164-32 (#8-32)	FH	FHS	FHA	832	4	5	6	8	10	12	14	16	20	24	.040	.163	.185	.237	.090	.281	
.190-24 (#10-24)	FH	FHS	FHA	024	—	5	6	8	10	12	14	16	20	24	.040	.189	.210	.256	.100	.281	
.190-32 (#10-32)	FH	FHS	FHA	032	—	5	6	8	10	12	14	16	20	24	.040	.189	.210	.256	.100	.281	
.250-20 (1/4-20)	FH	FHS	FHA	0420	—	—	6	8	10	12	14	16	20	24	.062	.249	.270	.337	.135	.312	
.313-18 (5/16-18)	FH	FHS	—	0518	—	—	—	8	10	12	14	16	20	24	.093	.311	.333	.376	.160	.375	

All dimensions are in millimeters.

METRIC	Thread Size x Pitch	Type			Thread Code	Length Code "L" ±0.4 (Length Code in millimeters)										Min. Sheet Thickness (1)	Hole Size in Sheet +0.08	Max. Hole in Attach. Parts	H ± 0.4	S Max. (2)	Min. Dist. Hole ⌀ to Edge
		Fastener Material				6	8	10	12	15	18	—	—	—	—						
		Steel	Stainless Steel	Aluminum																	
M2.5 x 0.45	FH	FHS	FHA	M2.5	6	8	10	12	15	18	—	—	—	—	1	2.5	3.1	4.1	1.95	5.4	
M3 x 0.5	FH	FHS	FHA	M3	6	8	10	12	15	18	20	25	—	—	1	3	3.6	4.6	2.1	5.6	
M3.5 x 0.6	FH	FHS	FHA	M3.5	6	8	10	12	15	18	20	25	30	—	1	3.5	4.1	5.3	2.25	6.4	
M4 x 0.7	FH	FHS	FHA	M4	6	8	10	12	15	18	20	25	30	35	1	4	4.6	5.9	2.4	7.2	
M5 x 0.8	FH	FHS	FHA	M5	—	8	10	12	15	18	20	25	30	35	1	5	5.6	6.5	2.7	7.2	
M6 x 1	FH	FHS	FHA	M6	—	—	10	12	15	18	20	25	30	35	1.6	6	6.6	8.2	3	7.9	
M8 x 1.25	FH	FHS	—	M8	—	—	—	12	15	18	20	25	30	35	2.4	8	8.6	9.6	3.7	9.6	

(1) See page 16 for installation tool requirements.

(2) Threads are gaugeable to within 2 pitches of the "S" Max. dimension. A class 3B/5H maximum material commercial nut shall pass up to the "S" Max. dimension.



SELF-CLINCHING STUDS AND PINS

TYPES FH4™/FHP™ FLUSH-HEAD STUDS FOR STAINLESS STEEL SHEETS

- Recommended for use in stainless steel sheets HRB (Rockwell “B” Scale) 92 or less and HB (Hardness Brinell) 195 or less.
- Type FHP offers optimum corrosion resistance and is ideal for medical, foodservice, and marine applications.

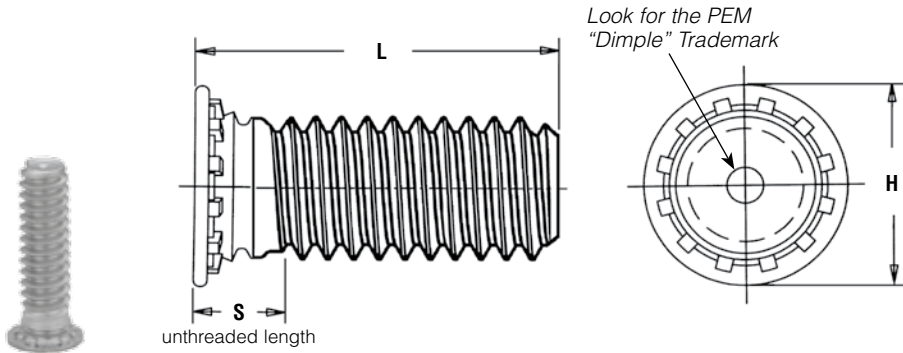

PART NUMBER DESIGNATION

FH	4	-	632	-	6
FH	P	-	632	-	6
↓	↓		↓		↓
Type	Material Code		Thread Size Code		Length Code

All dimensions are in inches.

UNIFIED	Thread Size	Type		Thread Code	Length Code "L" ±.015 (Length code in 16ths of an inch)									Sheet Thickness (2)	Hole Size in Sheet +.003 -.000	Max. Hole in Attach. Parts	H ±.015	S Max. (3)	Min. Dist. Hole Φ to Edge	
		Fastener Material	Stainless Steel (1)		.250	.312	.375	.500	.625	.750	.875	1.00	1.25							1.50
	.112-40 (#4-40)	FH4	FHP	440	4	5	6	8	10	12	14	16	—	—	.040-.095	.111	.131	.176	.085	.219
	.138-32 (#6-32)	FH4	FHP	632	4	5	6	8	10	12	14	16	20	24	.040-.095	.137	.157	.206	.090	.250
	.164-32 (#8-32)	FH4	FHP	832	4	5	6	8	10	12	14	16	20	24	.040-.095	.163	.183	.237	.090	.281
	.190-32 (#10-32)	FH4	FHP	032	—	5	6	8	10	12	14	16	20	24	.040-.095	.189	.209	.256	.100	.281
	.250-20 (1/4-20)	FH4	—	0420	—	—	6	8	10	12	14	16	20	24	.062-.117	.249	.269	.337	.135	.312

All dimensions are in millimeters.

METRIC	Thread Size x Pitch	Type		Thread Code	Length Code "L" ±0.4 (Length Code in millimeters)									Sheet Thickness (2)	Hole Size in Sheet +0.08	Max. Hole in Attach. parts	H ±0.4	S Max. (3)	Min. Dist. Hole Φ to Edge	
		Fastener Material	Stainless Steel (1)		6	8	10	12	15	18	20	25	30							35
	M3 x 0.5	FH4	FHP	M3	6	8	10	12	15	18	20	25	—	—	1 - 2.4	3	3.3	4.6	2.1	5.6
	M4 x 0.7	FH4	FHP	M4	6	8	10	12	15	18	20	25	30	35	1 - 2.4	4	4.7	5.9	2.4	7.2
	M5 x 0.8	FH4	FHP	M5	—	8	10	12	15	18	20	25	30	35	1 - 2.4	5	5.3	6.5	2.7	7.2
	M6 x 1	FH4	—	M6	—	—	10	12	15	18	20	25	30	35	1.6 - 3	6	6.8	8.2	3	7.9

(1) See material and finish specifications chart on page 15 for details.

(2) Performance may be reduced for studs installed into thicker sheets.

(3) Threads are gaugeable to within 2 pitches of the "S" Max. dimension. A class 3B/5H maximum material commercial nut shall pass up to the "S" Max. dimension.

SELF-CLINCHING STUDS AND PINS

TYPES FHL™/FHLS™ FLUSH, LOW-DISPLACEMENT HEAD STUDS

- Installs closer to the edge of a sheet than PEM Type FH/FHS studs without causing that edge to bulge.
- Flush-head for sheet thickness .040" / 1 mm and greater.
- Type FHL is recommended for use in steel or aluminum sheets HRB (Rockwell "B" Scale) 80 or less and HB (Hardness Brinell) 150 or less.
- Type FHLS is recommended for use in steel or aluminum sheets HRB (Rockwell "B" Scale) 70 or less and HB (Hardness Brinell) 125 or less.

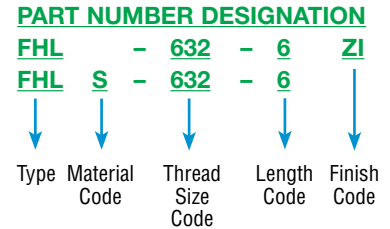
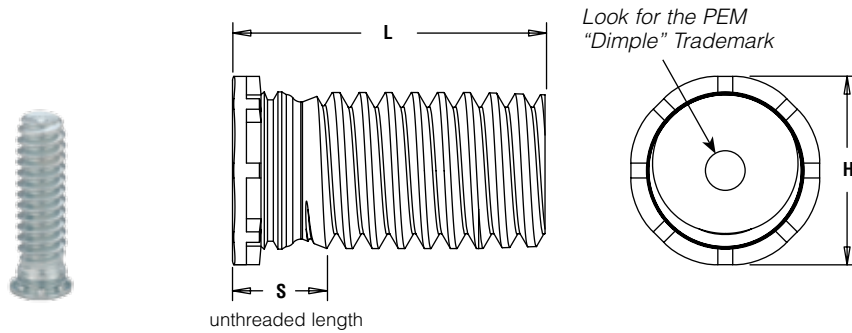

All dimensions are in inches.

UNIFIED	Thread Size	Type		Thread Code	Length Code "L" ±.015 (Length Code in 16ths of an inch)										Min. Sheet Thickness (1)	Hole Size in Sheet +.003 - .000	Max. Hole in Attach. Parts	H ±.015	S Max. (2)	Min. Dist. Hole to Edge
		Fastener Material			.250	.312	.375	.500	.625	.750	.875	1.00	1.25	1.50						
		Steel	Stainless Steel																	
.086-56 (#2-56)	FHL	FHLS	256	4	5	6	8	10	12	—	—	—	—	.040	.085	.100	.112	.080	.098	
.112-40 (#4-40)	FHL	FHLS	440	4	5	6	8	10	12	14	16	—	—	.040	.111	.126	.138	.085	.124	
.138-32 (#6-32)	FHL	FHLS	632	4	5	6	8	10	12	14	16	20	24	.040	.137	.152	.164	.090	.150	
.164-32 (#8-32)	FHL	FHLS	832	4	5	6	8	10	12	14	16	20	24	.040	.163	.178	.190	.090	.176	
.190-32 (#10-32)	FHL	FHLS	032	—	5	6	8	10	12	14	16	20	24	.040	.189	.204	.225	.100	.210	

All dimensions are in millimeters.

METRIC	Thread Size x Pitch	Type		Thread Code	Length Code "L" ±0.4 (Length Code in millimeters)										Min. Sheet Thickness (1)	Hole Size in Sheet +0.08	Max. Hole in Attach. Parts	H ±0.4	S Max. (2)	Min. Dist. Hole to Edge
		Fastener Material			6	8	10	12	15	18	—	—	—	—						
		Steel	Stainless Steel																	
M2.5 x 0.45	FHL	FHLS	M2.5	6	8	10	12	15	18	—	—	—	—	1	2.5	2.9	3.15	2.1	2.8	
M3 x 0.5	FHL	FHLS	M3	6	8	10	12	15	18	20	25	—	—	1	3	3.2	3.65	2.1	3.3	
M3.5 x 0.6	FHL	FHLS	M3.5	6	8	10	12	15	18	20	25	30	—	1	3.5	3.9	4.15	2.3	3.8	
M4 x 0.7	FHL	FHLS	M4	6	8	10	12	15	18	20	25	30	35	1	4	4.5	4.65	2.4	4.3	
M5 x 0.8	FHL	FHLS	M5	—	8	10	12	15	18	20	25	30	35	1	5	5.2	5.9	2.7	5.6	

(1) See page 17 for installation tool requirements.

(2) Threads are gaugeable to within 2 pitches of the "S" Max. dimension. A class 3B/5H maximum material commercial nut shall pass up to the "S" Max. dimension.

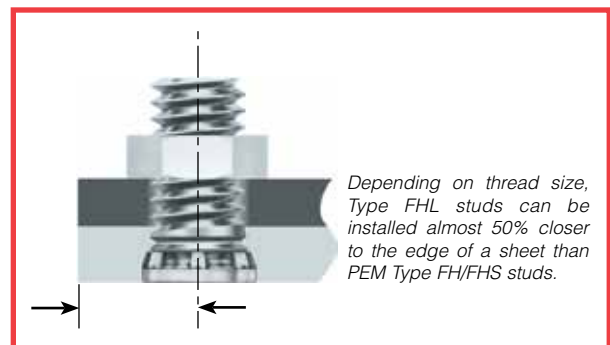

SELF-CLINCHING STUDS AND PINS

TYPES TFH/TFHS NON-FLUSH STUDS

- Non-flush for sheets as thin as .020" / 0.51 mm.
- Type TFH is recommended for use in steel or aluminum sheets HRB (Rockwell "B" Scale) 80 or less and HB (Hardness Brinell) 150 or less.
- Type TFHS is recommended for use in steel or aluminum sheets HRB (Rockwell "B" Scale) 70 or less and HB (Hardness Brinell) 125 or less.

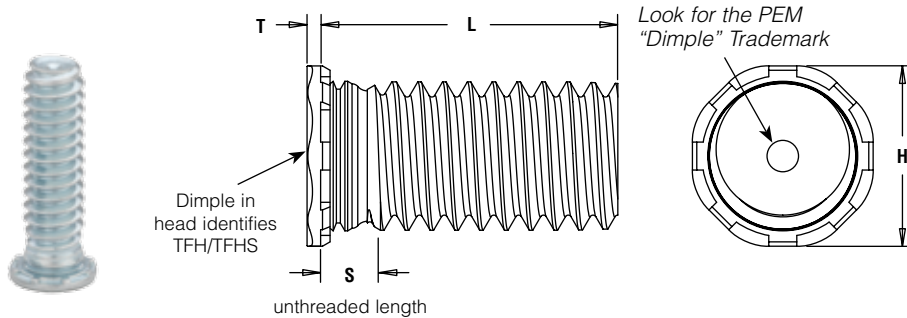

PART NUMBER DESIGNATION

TFH	-	632	-	6	ZI
TFH	S	632	-	6	
↓	↓	↓	↓	↓	↓
Type	Material Code	Thread Size Code	Length Code	Finish Code	

All dimensions are in inches.

UNIFIED	Thread Size	Type		Thread Code	Length Code "L" ±.015 (Length Code in 16ths of an inch)									Min. Sheet Thickness (1)	Hole Size in Sheet +.003 -.000	Max. Hole in Attach. Parts	H ±.015	S Max. (2)	T Max.	Min. Dist. Hole to Edge		
		Fastener Material	Steel		Stainless Steel	.250	.312	.375	.500	.625	.750	.875	1.00								1.25	1.50
		Steel	Stainless Steel																			
.086-56 (#2-56)	TFH	TFHS	256	4	5	6	8	10	12	—	—	—	—	.020	.085	.105	.141	.070	.025	.187		
.112-40 (#4-40)	TFH	TFHS	440	4	5	6	8	10	12	14	—	—	—	.020	.111	.131	.176	.070	.025	.219		
.138-32 (#6-32)	TFH	TFHS	632	4	5	6	8	10	12	14	16	20	24	.020	.137	.157	.203	.070	.025	.250		
.164-32 (#8-32)	TFH	TFHS	832	4	5	6	8	10	12	14	16	20	24	.020	.163	.183	.234	.070	.025	.281		
.190-24 (#10-24)	TFH	TFHS	024	—	5	6	8	10	12	14	16	20	24	.020	.189	.209	.250	.090	.025	.281		
.190-32 (#10-32)	TFH	TFHS	032	—	5	6	8	10	12	14	16	20	24	.020	.189	.209	.250	.090	.025	.281		

All dimensions are in millimeters.

METRIC	Thread Size x Pitch	Type		Thread Code	Length Code "L" ±0.4 (Length Code in millimeters)									Min. Sheet Thickness (1)	Hole Size in Sheet +0.08	Max. Hole in Attach. Parts	H ±0.4	S Max. (2)	T Max.	Min. Dist. Hole to Edge		
		Fastener Material	Steel		Stainless Steel	6	8	10	12	15	18	20	25								—	—
		Steel	Stainless Steel																			
M3 x 0.5	TFH	TFHS	M3	6	8	10	12	15	18	20	25	—	—	0.51	3	3.3	4.5	1.8	0.64	5.6		
M4 x 0.7	TFH	TFHS	M4	—	8	10	12	15	18	20	25	30	35	0.51	4	4.7	5.8	1.8	0.64	7.2		
M5 x 0.8	TFH	TFHS	M5	—	8	10	12	15	18	20	25	30	35	0.51	5	5.3	6.4	2.3	0.64	7.2		

(1) See page 18 for installation tool requirements.

(2) Threads are gaugeable to within 2 pitches of the "S" Max. dimension. A class 3B/5H maximum material commercial nut shall pass up to the "S" Max. dimension.



SELF-CLINCHING STUDS AND PINS

TYPES HFH/HFHS/HFHB HEAVY-DUTY STUDS

- Types HFH and HFHS are for high-strength applications in sheets as thin as .050"/1.3 mm.
- Type HFHB is for superior electrical/mechanical attachment in copper.
- Type HFH is recommended for use in steel or aluminum sheets HRB (Rockwell "B" Scale) 85 or less and HB (Hardness Brinell) 165 or less.
- Type HFHS is recommended for use in steel or aluminum sheets HRB (Rockwell "B" Scale) 70 or less and HB (Hardness Brinell) 125 or less.
- Type HFHB is recommended for use in copper sheets HRB (Rockwell "B" Scale) 55 or less and HB (Hardness Brinell) 83 or less.

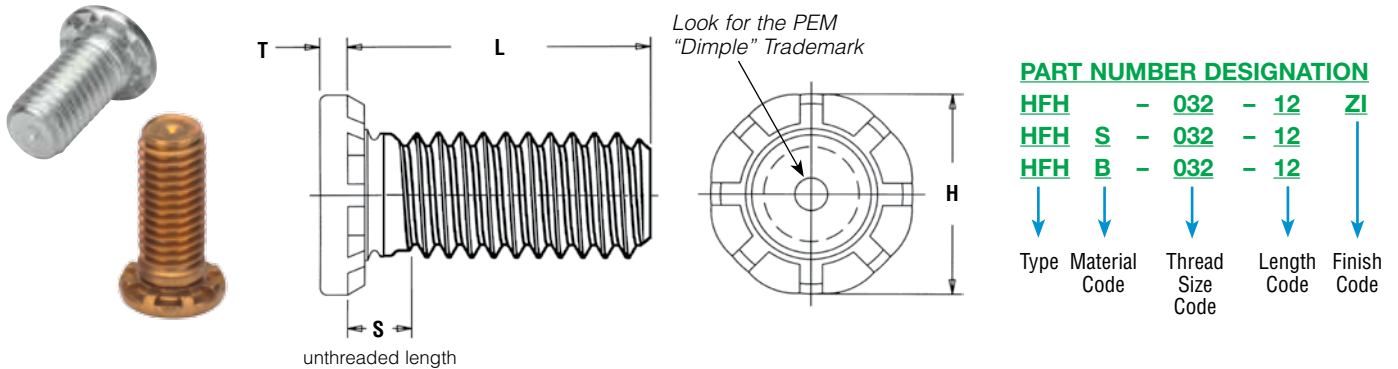

All dimensions are in inches.

UNIFIED	Thread Size	Type			Thread Code	Length Code "L" ±.015 (Length Code in 16ths of an inch)						Min. Sheet Thickness	Hole Size in Sheet +.005 -.000	Max. Hole in Attach. Parts	H ±.01	S Max. (2)	T Max.	Min. Dist. Hole ⌀ to Edge	
		Fastener Material				.500	.750	1.00	1.25	1.50	1.75								2.00
		Steel	Stainless Steel	Phosphor Bronze (1)															
.190-32 (#10-32)	HFH	HFHS	HFHB	032	8	12	16	20	24	28	32	.050	.190	.252	.300	.105	.040	.415	
.250-20 (1/4-20)	HFH	HFHS	HFHB	0420	8	12	16	20	24	28	32	.060	.250	.312	.380	.125	.050	.460	
.313-18 (5/16-18)	HFH	HFHS	HFHB	0518	8	12	16	20	24	28	32	.075	.312	.374	.480	.140	.070	.500	
.375-16 (3/8-16)	HFH	HFHS	HFHB	0616	—	12	16	20	24	28	32	.090	.375	.437	.580	.155	.085	.530	

Tensile strength: HFH - 120 ksi / HFHS - 75 ksi / HFHB - 60 ksi.

All dimensions are in millimeters.

METRIC	Thread Size x Pitch	Type			Thread Code	Length code "L" ±0.4 (Length Code in millimeters)						Min. Sheet Thickness	Hole Size in Sheet +0.13	Max. Hole in Attach. Parts	H ±0.25	S Max. (2)	T Max.	Min. Dist. Hole ⌀ to Edge	
		Fastener Material				15	20	25	30	35	40								50
		Steel	Stainless Steel	Phosphor Bronze(1)															
M5 x 0.8	HFH	HFHS	HFHB	M5	15	20	25	30	35	40	50	1.3	5	6.4	7.8	2.7	1.14	10.7	
M6 x 1	HFH	HFHS	HFHB	M6	15	20	25	30	35	40	50	1.5	6	7.5	9.4	2.8	1.27	11.5	
M8 x 1.25	HFH	HFHS	HFHB	M8	15	20	25	30	35	40	50	2	8	9.5	12.5	3.5	1.78	12.7	
M10 x 1.5	HFH	HFHS	HFHB	M10	15	20	25	30	35	40	50	2.3	10	11.5	15.7	4.1	2.29	13.7	

Tensile strength: HFH - 900 MPa / HFHS - 515 MPa / HFHB - 415 MPa.

- (1) The electrical resistance (tested at 10 amps DC) between phosphor bronze studs and copper busbars is below 104μ ohms and 62μ ohms for the #10-32 / M5 and 3/8-16 / M10 thread sizes respectively, after repeated thermal and mechanical cycling. For complete electrical resistance test data for type HFHB studs installed in copper, see bulletin entitled "Electrical Resistance of Type HFHB Studs Installed in Copper" on our website.
- (2) Threads are gaugeable to within 2 pitches of the "S" Max. dimension. A class 3B/5H maximum material commercial nut shall pass up to the "S" Max. dimension.



SELF-CLINCHING STUDS AND PINS

TYPE HFE™ HEAVY DUTY STUDS FOR THIN SHEETS

- Enlarged head diameter reduces stress on panel.
- Thicker head allows for larger hole in attached panels.
- Clinch design provides high-strength in sheets as thin as .040" / 1 mm.
- Recommended for use in steel or aluminum sheets HRB (Rockwell "B" Scale) 85 or less and HB (Hardness Brinell) 165 or less.

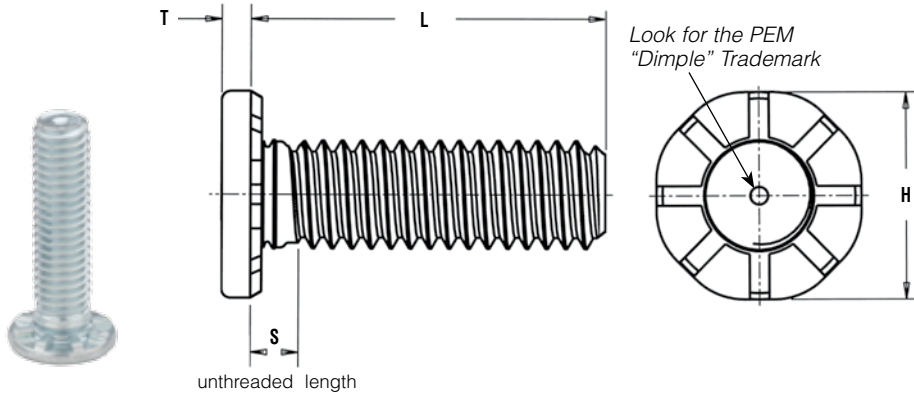

PART NUMBER DESIGNATION

HFE - 632 - 12 ZI

↓ ↓ ↓ ↓

Type Thread Size Code Length Code Finish Code

All dimensions are in inches.

UNIFIED	Thread Size	Type	Thread Code	Length Code "L" ±.015 (Length Code in 16ths of an inch)						Min. Sheet Thickness (1)	Hole Size In Sheet +.005 -.000	Max. Hole In Attached Parts	H ±.01	S Max. (2)	T Max.	Min. Dist. Hole To Edge	
		Fastener Material		.500	.750	1.00	1.25	1.50	1.75								2.00
	Steel																
	.190-32 (#10-32)	HFE	032	8	12	16	20	24	28	32	.040	.190	.280	.357	.102	.048	.360
	.250-20 (1/4-20)	HFE	0420	8	12	16	20	24	28	32	.040	.250	.340	.462	.118	.060	.470
	.313-18 (5/16-18)	HFE	0518	8	12	16	20	24	28	32	.060	.312	.402	.586	.133	.083	.560

Tensile strength: 120 ksi

All dimensions are in millimeters.

METRIC	Thread Size x Pitch	Type	Thread Code	Length Code "L" ±.0.4 (Length Code in millimeters)						Min. Sheet Thickness (1)	Hole Size In Sheet +0.13	Max. Hole In Attached Parts	H ±0.25	S Max. (2)	T Max.	Min. Dist. Hole To Edge	
		Fastener Material		15	20	25	30	35	40								50
	Steel																
	M5 x 0.8	HFE	M5	15	20	25	30	35	40	50	1	5	7.3	9.6	2.6	1.35	10
	M6 x 1	HFE	M6	15	20	25	30	35	40	50	1	6	8.3	11.35	2.8	1.52	11.5
	M8 x 1.25	HFE	M8	15	20	25	30	35	40	50	1.5	8	10.3	15.3	3.3	2.13	14.5

Tensile strength: 900 MPa

(1) See page 19 for installation tool requirements.

(2) Threads are gaugeable to within 2 pitches of the "S" Max. dimension. A class 3B/5H maximum material commercial nut shall pass up to the "S" Max. dimension.

SELF-CLINCHING STUDS AND PINS

TYPES HFG8™/HF109™ HEAVY DUTY, HIGH TENSILE STRENGTH STUDS

- Types HFG8 / HF109 are for heavy-duty applications in sheets as thin as .040" / 1 mm.
- Grade 8 and property class 10.9 studs meeting 150 ksi/1040 MPa minimum.
- Recommended for use in steel or HSLA steel sheets HRB (Rockwell "B" Scale) 89 or less and HB (Hardness Brinell) 180 or less.
- Large head diameter spreads compressive stress on panel.

High Tensile Strength

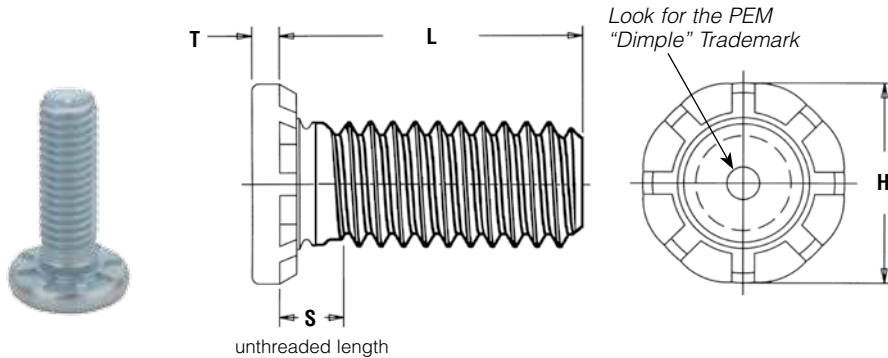

PART NUMBER DESIGNATION

HF G8 - 0420 - 12 ZI
HF 109 - M6 - 20 ZI

↓ ↓ ↓ ↓ ↓

Type Strength Code Thread Size Code Length Code Finish Code

All dimensions are in inches.

UNIFIED	Thread Size	Type	Thread Code	Length Code "L" ±.015 (1) (Length Code in 16ths of an inch)			Min. Sheet Thickness	Hole Size in Sheet +.005 - .000	Max. Hole in Attached Parts	H ±.01	S Max. (2)	T Max.	Min. Dist. Hole C/L To Edge
		Steel		.500	.750	1.00							
	.190-32 (#10-32)	HFG8	032	8	12	16	.040	.190	.280	.391	.105	.077	.469
.250-20 (1/4-20)	HFG8	0420	8	12	16	.040	.250	.340	.507	.125	.090	.709	
.313-18 (5/16-18)	HFG8	0518	—	12	16	.060	.312	.402	.645	.140	.126	.827	

Tensile strength: 150 ksi

All dimensions are in millimeters.

METRIC	Thread Size x Pitch	Type	Thread Code	Length Code "L" ±0.4 (1) (Length Code in millimeters)			Min. Sheet Thickness	Hole Size in Sheet +0.13	Max. Hole in Attached Parts	H ±0.25	S Max. (2)	T Max.	Min. Dist. Hole C/L To Edge
		Steel		15	20	25							
M5 x 0.8	HF109	M5	15	20	25	1	5	7.3	10.3	2.6	2.06	11.5	
M6 x 1	HF109	M6	15	20	25	1	6	8.3	12.1	2.7	2.29	18.0	
M8 x 1.25	HF109	M8	—	20	25	1.5	8	10.3	16.6	3.4	3.25	21.0	

Tensile strength: 1040 MPa

- (1) Other lengths available up to a maximum of 1.5" (unified) and 40 mm (metric) on special order.
- (2) Threads are gaugeable to within 2 pitches of the "S" Max. dimension. A class 3B/5H maximum material commercial nut shall pass up to the "S" Max. dimension.

To be sure that you are getting genuine PEM products, look for the PEM stamp. Studs within the size range of the SAE and ISO specs are also identified with the Grade 8 and 10.9 head markings respectively.

HFG8 Marking*

* Thread size #10-32 does not have SAE head marking since it is technically not within the size range of the specification.

SELF-CLINCHING STUDS AND PINS

TYPES FH/FHS/FHA FLUSH-HEAD PINS

- Flush-head for sheet thickness of .040" / 1 mm and greater.
- Type FH is recommended for use in steel or aluminum sheets HRB (Rockwell "B" Scale) 80 or less and HB (Hardness Brinell) 150 or less.
- Type FHS is recommended for use in steel or aluminum sheets HRB (Rockwell "B" Scale) 70 or less and HB (Hardness Brinell) 125 or less.
- Type FHA is recommended for use in aluminum sheets HRB (Rockwell "B" Scale) 50 or less and HB (Hardness Brinell) 82 or less.

These PEM® pins are only available on special order. See Types TPS, TP4, and TPXS pins on page 14 for standard diameter pins.

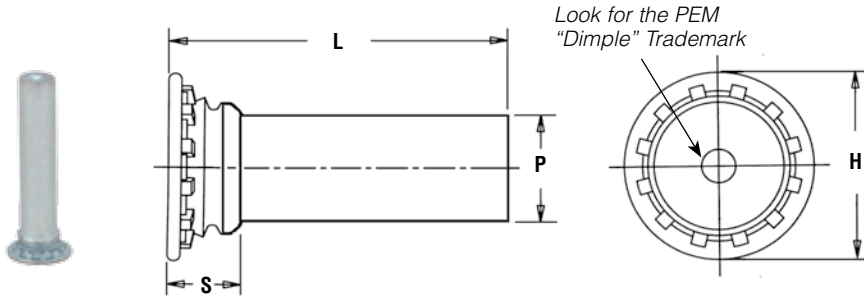

PART NUMBER DESIGNATION

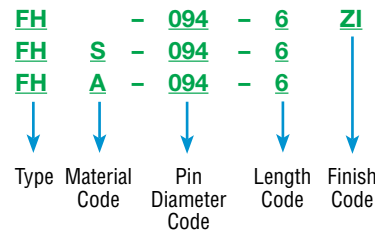

All dimensions are in inches.

UNIFIED	Nominal Pin Diameter P±.002	Type			Pin Dia. Code	Length Code "L" ±.015 (Length Code in 16ths of an inch)										Min. Sheet Thickness	Hole Size in Sheet +.003 - .000	H ± .015	S Max. (1)	Min. Dist. Hole ⌀ to Edge
		Fastener Material				.250	.312	.375	.500	.625	.750	.875	1.00	1.25	1.50					
		Steel	Stainless Steel	Aluminum																
.073	FH	FHS	FHA	073	4	5	6	8	10	—	—	—	—	.040	.085	.15	.075	.19		
.084	FH	FHS	FHA	084	4	5	6	8	10	12	—	—	—	.040	.099	.16	.085	.22		
.094	FH	FHS	FHA	094	4	5	6	8	10	12	—	—	—	.040	.111	.18	.085	.22		
.103	FH	FHS	FHA	103	4	5	6	8	10	12	—	—	—	.040	.118	.18	.085	.22		
.106	FH	FHS	FHA	106	4	5	6	8	10	12	14	16	20	.040	.125	.19	.090	.22		
.116	FH	FHS	FHA	116	4	5	6	8	10	12	14	16	20	.040	.137	.21	.090	.25		
.120	FH	FHS	FHA	120	4	5	6	8	10	12	14	16	20	24	.040	.137	.21	.090	.25	
.137	FH	FHS	FHA	137	4	5	6	8	10	12	14	16	20	24	.040	.157	.23	.090	.28	
.141	FH	FHS	FHA	141	4	5	6	8	10	12	14	16	20	24	.040	.163	.24	.090	.28	
.160	FH	FHS	FHA	160	4	5	6	8	10	12	14	16	20	24	.040	.189	.26	.100	.28	
.167	FH	FHS	FHA	167	—	5	6	8	10	12	14	16	20	24	.040	.189	.26	.100	.28	
.173	FH	FHS	FHA	173	—	5	6	8	10	12	14	16	20	24	.040	.197	.26	.100	.28	
.207	FH	FHS	FHA	207	—	5	6	8	10	12	14	16	20	24	.062	.236	.32	.135	.31	
.215	FH	FHS	FHA	215	—	—	—	8	10	12	14	16	20	24	.062	.250	.34	.135	.31	
.223	FH	FHS	FHA	223	—	—	—	8	10	12	14	16	20	24	.062	.250	.34	.135	.31	
.273	FH	FHS	FHA	273	—	—	—	8	10	12	14	16	20	24	.093	.312	.38	.160	.38	
.281	FH	FHS	FHA	281	—	—	—	8	10	12	14	16	20	24	.093	.312	.38	.160	.38	

All dimensions are in millimeters.

METRIC	Nominal Pin Diameter P±0.05	Type			Pin Dia. Code	Length Code "L" ±0.4 (Length Code in millimeters)										Min. Sheet Thickness	Hole Size in Sheet +0.08	H ± 0.4	S Max. (1)	Min. Dist. Hole ⌀ to Edge
		Fastener Material				6	8	10	12	15	18	20	25	30	35					
		Steel	Stainless Steel	Aluminum																
3	FH	FHS	FHA	3MM	6	8	10	12	15	18	20	25	30	—	1	3.5	5.3	2.3	6.4	
4	FH	FHS	FHA	4MM	—	8	10	12	15	18	20	25	30	35	1	4.1	6	2.3	7.1	
5	FH	FHS	FHA	5MM	—	8	10	12	15	18	20	25	30	35	1	5.5	7.5	2.55	7.6	

(1) Pin diameter may exceed max. in this region.

SELF-CLINCHING STUDS AND PINS

TYPE SGPC™ SWAGING COLLAR STUDS

- Installs into sheets as thin as .024" / 0.6 mm.
- Can be used to attach dissimilar materials.
- Can accommodate multiple panels as long as the total thickness does not exceed the maximum sheet thickness.⁽¹⁾
- Can be installed into most materials, including stainless steel and rigid non-metallic panels.
- Allows for close centerline-to-edge distance.

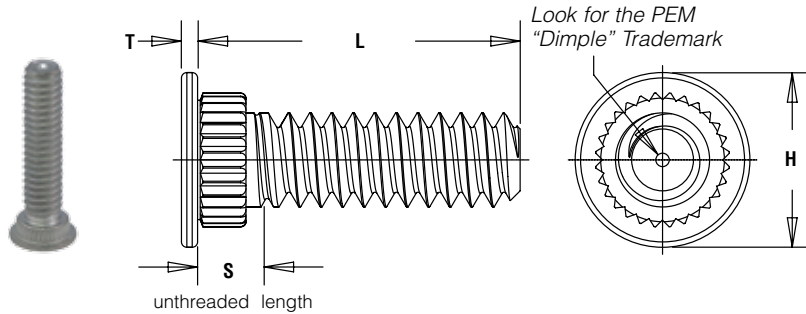

PART NUMBER DESIGNATION

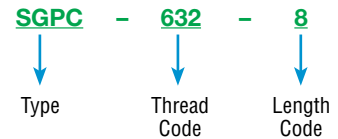

All dimensions are in inches.

UNIFIED	Thread Size	Type	Thread Code	Length Code "L" ±.015 (Length Code in 16ths of an inch)								Sheet Thickness (2)	Hole Size in Sheet +.003 -.000	Hole Dia. of Attached Panel +.005 - .000	H ±.010	S Max. (3)	T ±.004	Min. Dist. Hole ⌀ to Edge	
		Fastener Material		.312	.375	.500	.625	.750	.875	1.00	1.25								1.50
		Stainless Steel																	
	.086-56 (#2-56)	SGPC	256	5	6	8	10	12	—	—	—	—	.024 - .047	.145	.182	.189	.093	.020	.130
	.112-40 (#4-40)	SGPC	440	5	6	8	10	12	14	16	20	—	.024 - .047	.171	.205	.228	.101	.024	.160
	.138-32 (#6-32)	SGPC	632	5	6	8	10	12	14	16	20	24	.024 - .047	.196	.229	.256	.109	.024	.180
	.164-32 (#8-32)	SGPC	832	5	6	8	10	12	14	16	20	24	.024 - .047	.223	.259	.279	.109	.024	.200
	.190-32 (#10-32)	SGPC	032	5	6	8	10	12	14	16	20	24	.024 - .047	.249	.280	.307	.109	.024	.210
	.250-20 (1/4-20)	SGPC	0420	—	6	8	10	12	14	16	20	24	.024 - .047	.309	.343	.366	.131	.028	.250

All dimensions are in millimeters.

METRIC	Thread Size x Pitch	Type	Thread Code	Length Code "L" ±0.4 (Length Code in millimeters)								Sheet Thickness (2)	Hole Size in Sheet +0.08	Hole Dia. of Attached Panel +0.13	H ±0.25	S Max. (3)	T ±0.1	Min. Dist. Hole ⌀ to Edge	
		Fastener Material		8	10	12	15	18	—	—	—								—
		Stainless Steel																	
	M2.5 x 0.45	SGPC	M2.5	8	10	12	15	18	—	—	—	—	0.6 - 1.2	4	4.95	5	2.4	0.5	3.9
	M3 x 0.5	SGPC	M3	8	10	12	15	18	20	25	—	—	0.6 - 1.2	4.5	5.45	6	2.5	0.6	4.3
	M4 x 0.7	SGPC	M4	8	10	12	15	18	20	25	30	—	0.6 - 1.2	5.5	6.3	7	2.7	0.6	4.9
	M5 x 0.8	SGPC	M5	8	10	12	15	18	20	25	30	35	0.6 - 1.2	6.5	7.45	8	2.8	0.6	5.5
	M6 x 1	SGPC	M6	—	10	12	15	18	20	25	30	35	0.6 - 1.2	7.5	8.3	9	3	0.7	6.2

- (1) When using the fastener to attach more than one sheet or panel, the stud may seem slightly loose after installation. This is a normal condition in some applications and will not effect the stud's performance.
- (2) See installation data for tooling requirements. Contact Technical Support (techsupport@pemnet.com) for other thicknesses.
- (3) Threads are gaugeable to within 2 pitches on the "S" Max. dimension. A class 3B/5H maximum material commercial nut shall pass up to the "S" Max. dimension.

SELF-CLINCHING STUDS AND PINS

TYPES TPS™/TP4™ FLUSH-HEAD PILOT PINS

- Flush-head for sheet thickness of .040" / 1 mm and greater.
- Satisfies a wide range of positioning, pivot, and alignment applications.
- Chamfered end makes mating hole location easy.
- Type TPS recommended for use in steel or aluminum sheets HRB (Rockwell "B" Scale) 70 or less and HB (Hardness Brinell) 125 or less.
- Type TP4 recommended for use in stainless steel sheets HRB (Rockwell "B" Scale) 92 or less and HB (Hardness Brinell) 195 or less.

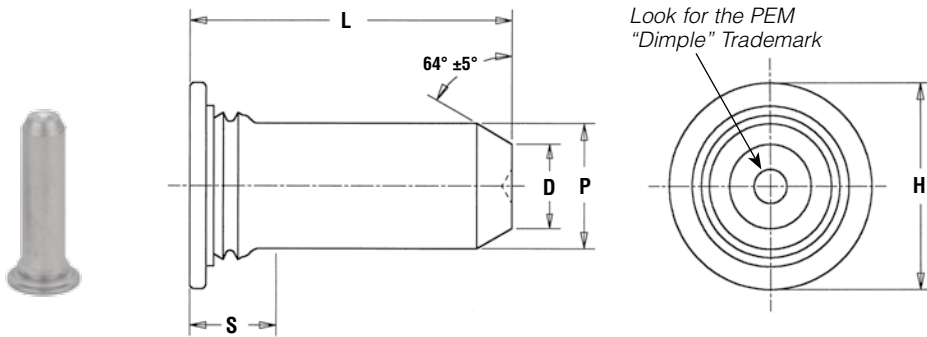

PART NUMBER DESIGNATION

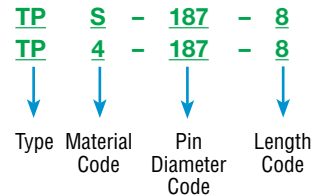

All dimensions are in inches.

UNIFIED	Pin Diameter P ± .002	Type		Pin Diameter Code	Length Code "L" ± .015 (Length Code in 16ths of an inch)					Min. Sheet Thickness	Hole Size in Sheet + .003 - .000	D ± .006	H ± .015	S Max. (1)	Min. Distance Hole \varnothing to Edge
		Fastener Material			.375	.500	.625	.750	1.00						
		300 Series Stainless Steel	400 Series Stainless Steel												
	.125	TPS	TP4	125	6	8	10	12	—	.040	.144	.090	.205	.090	.250
	.187	TPS	TP4	187	6	8	10	12	16	.040	.205	.132	.270	.090	.280
	.250	TPS	TP4	250	—	8	10	12	16	.040	.272	.177	.335	.090	.310

All dimensions are in millimeters.

METRIC	Pin Diameter P ± 0.05	Type		Pin Diameter Code	Length Code "L" ± 0.4 (Length Code in millimeters)					Min. Sheet Thickness	Hole Size in Sheet + 0.08	D ± 0.15	H ± 0.4	S Max. (1)	Min. Distance Hole \varnothing to Edge
		Fastener Material			8	10	12	16	—						
		300 Series Stainless Steel	400 Series Stainless Steel												
	3	TPS	TP4	3MM	8	10	12	16	—	1	3.5	2.11	5.2	2.29	6.4
	4	TPS	TP4	4MM	8	10	12	16	—	1	4.5	2.82	6.12	2.29	7.1
	5	TPS	TP4	5MM	—	10	12	16	20	1	5.5	3.53	7.19	2.29	7.6
	6	TPS	TP4	6MM	—	—	12	16	20	1	6.5	4.24	8.13	2.29	7.9

(1) Pin diameter may exceed max. in this region.

TYPE TPXS™ SELF-CLINCHING PILOT PIN

- Meets the ATCA PICMG 3.0 specification.
- 15° tapered point makes engaging the mating hole easy.



Min. Sheet Thickness: 1 mm
Hole Size In Sheet: 3.5 mm +0.08
Min. Dist. Hole C/L To Edge: 6.4 mm

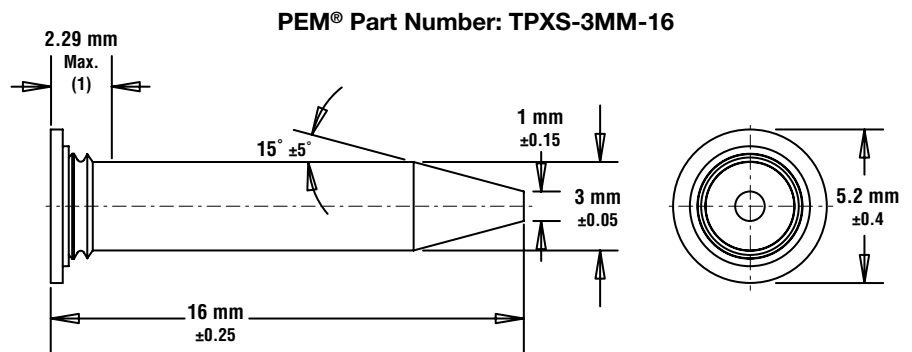

(1) Pin diameter may exceed max. in this region.

SELF-CLINCHING STUDS AND PINS

MATERIAL AND FINISH SPECIFICATIONS

Type	Threads (1)	Fastener Materials						Standard Finishes			Optional Finish (2)	For use in Sheet Hardness: (6)								
	External, ASME B1.1, 2A /ASME B1.13M 6g	Heat-Treated Carbon Steel	Heat-Treated Medium Carbon Alloy Steel	300 Series Stainless Steel	Aluminum (Plain Finish)	CDA #510 Phosphor Bronze	Age Hardened A286 Stainless Steel	400 Series Stainless Steel	No Finish (4)	Zinc plated, 5µm, Colorless (5)	Passivated and/or Tested Per ASTM A380	Zinc plated, 5µm, Yellow (5)	HRB 50 / HB 82 or Less	HRB 55 / HB 83 or Less	HRB 70 / HB 125 or Less	HRB 80 / HB 150 or Less	HRB 85 / HB 165 or Less	HRB 89 / HB 180 or Less	HRB 92 / HB 195 or Less	Any Sheet Hardness
FH	•	•							•		•				•					
FHS	•			•						•				•						
FHA	•				•				• (3)			•								
FH4	•							•		•									•	
FHP	•						•			•									•	
FHL	•	•							•		•				•					
FHLS	•			•						•				•						
TFH	•	•							•		•			•						
TFHS	•			•						•				•						
HFE	•	•							•		•					•				
HFH	•	•							•		•					•				
HFHB	•					•			•				•							
HFHS	•			•						•				•						
HFG8	•		•						•		•							•		
HF109	•		•						•		•							•		
SGPC				•						•										•
TPS				•						•				•						
TP4				•				•		•									•	
TPXS				•						•				•						
Part Number Codes for Finishes									X	ZI	None	ZC								

- (1) For plated studs, Class 2A/6g, the maximum major and pitch diameter, after plating, may equal basic sizes and be gauged to Class 3A/4h. Per ASME B1.1, Section 7, Paragraph 7.2 and ASME B1.13M, Section 8, paragraph 8.2.
- (2) Special order with additional charge.
- (3) Part numbers for aluminum studs have no finish suffix.
- (4) "X" suffix studs may have pitch diameters and major diameters below 2A "Basic", per ANSI B1.1, Section 7, and B1.13M, Section 8 to allow for minimum of 0.0002" / 0.0051 mm of plating.
- (5) See PEM Technical Support section of our web site for related plating standards and specifications.
- (6) HRB - Hardness Rockwell "B" Scale. HB - Hardness Brinell.

SELF-CLINCHING STUDS AND PINS

INSTALLATION - TYPES FH/FHS/FHA THREADED STUDS

1. Prepare properly sized mounting hole in sheet. Do not perform any secondary operations such as deburring.
2. Insert stud through mounting hole (punch side) of sheet and into anvil hole.
3. With punch and anvil surfaces parallel, apply squeezing force to embed the head of the stud flush in the sheet. In most cases, when using sheets .060" / 1.51 mm and thicker, the anvil requires only a straight thru hole to accommodate the stud (see illustrations below for details). For sheets less than .060 / 1.51 mm, the hole requires a countersink with dimension A at the top to provide for metal flow around the shank of the stud.

Tooling for sheet thicknesses less than .060 / 1.51 mm with #2 thru #10 / M3 thru M5 thread sizes and less than .093" / 2.4 mm for 1/4" / M6 threads.

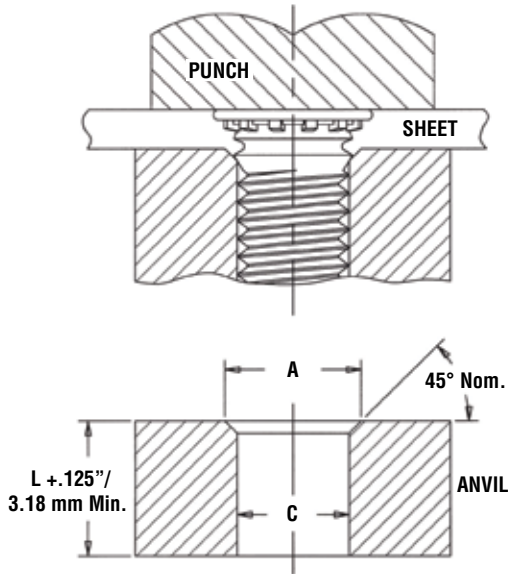

Tooling for sheet thicknesses .060" / 1.51 mm and greater with #2 thru #10 / M3 thru M5 thread sizes and .093" / 2.41 mm and greater for 1/4" and 5/16" / M6 and M8 threads.

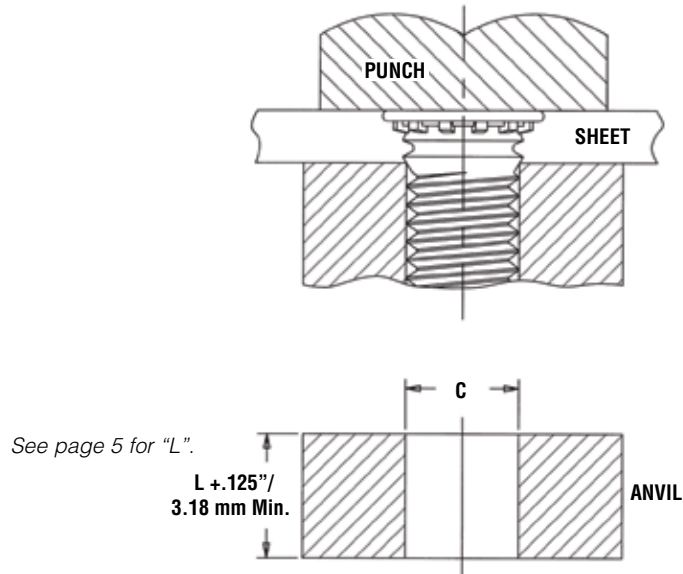

See page 5 for "L".

UNIFIED	Thread Code	Anvil Dimensions (in.)		Anvil Part No. For Sheets > .060"	Anvil Part No. For Sheets ≤ .059"	Punch Part Number
		A	C			
	256	.110-.114	.087-.090	970200005300	970200240300	975200048
	440	.136-.140	.113-.116	970200006300	970200241300	
	632	.162-.166	.139-.142	970200007300	970200243300	
	832	.188-.192	.165-.168	970200008300	970200245300	
	024/032	.216-.220	.191-.194	970200009300	970200246300	
	0420	.295-.300	.250-.253	970200010300	970200249300	
				For Sheets > .075"	For Sheets ≤ .074"	
	0518	.334-.338	.3125-.3155	970200011300	970200250300	

METRIC	Thread Code	Anvil Dimensions (mm)		Anvil Part No. For Sheets > 1.51 mm	Anvil Part No. For Sheets ≤ 1.5 mm	Punch Part Number
		A + 0.1	C + 0.08			
	M2.5	3.1	2.53	970200300300	970200493300	975200048
	M3	3.6	3.03	970200229300	970200242300	
	M3.5	4.1	3.53	970200007300	970200243300	
	M4	4.6	4.03	970200019300	970200244300	
	M5	5.6	5.03	970200020300	970200247300	
	M6	6.6	6.03	970200230300	970200248300	
				For Sheets > 1.9 mm	For Sheets ≤ 1.9 mm	
	M8	8.6	8.03	970200231300	970200251	

SELF-CLINCHING STUDS AND PINS

INSTALLATION - TYPES FH4™/FHP™ STUDS FOR STAINLESS STEEL SHEETS

1. Prepare properly sized mounting hole in sheet. Do not perform any secondary operations such as deburring.
2. Insert stud through mounting hole (punch side) of sheet and into anvil hole.
3. With punch and anvil surfaces parallel, apply squeezing force to embed the head of the stud flush in the sheet.

For Type FH4/FHP studs, a special anvil with a raised ring is required to create a proper installation. The raised ring acts as a second displacer of the stainless sheet material, thereby ensuring that the annular groove is filled. Please see page 6 for recommended sheet thickness range. The special anvils are available from PEM stock or can be machined from suitable tool steel. A hardness of HRC 55 / HB 547 minimum is required to provide long anvil life. We recommend measuring the "P" dimension every 5000 installations to ensure that the anvil remains within specification.

UNIFIED	Thread Code	Anvil Dimensions (in.)						Anvil Part Number	Punch Part Number
		A +.003 -.000	B ±.002	C ±.002	P ±.001	R ₁ Max.	R ₂ Max.		
	440	.113	.144	.174	.010	.003	.005	8001645	975200048
	632	.140	.170	.200	.010	.003	.005	8001644	
	832	.166	.202	.236	.010	.003	.005	8001643	
	032	.191	.235	.275	.010	.003	.005	8001642	
	0420	.252	.324	.360	.020	.003	.005	8002535	

METRIC	Thread Code	Anvil Dimensions (mm)						Anvil Part Number	Punch Part Number
		A +0.08	B ±0.05	C ±0.05	P ±.025	R ₁ Max.	R ₂ Max.		
	M3	3.05	3.81	4.57	0.25	0.08	0.13	8001678	975200048
	M4	4.04	4.95	5.82	0.25	0.08	0.13	8001677	
	M5	5.08	6.15	7.16	0.25	0.08	0.13	8001676	
	M6	6.05	7.87	8.79	0.51	0.08	0.13	8002536	

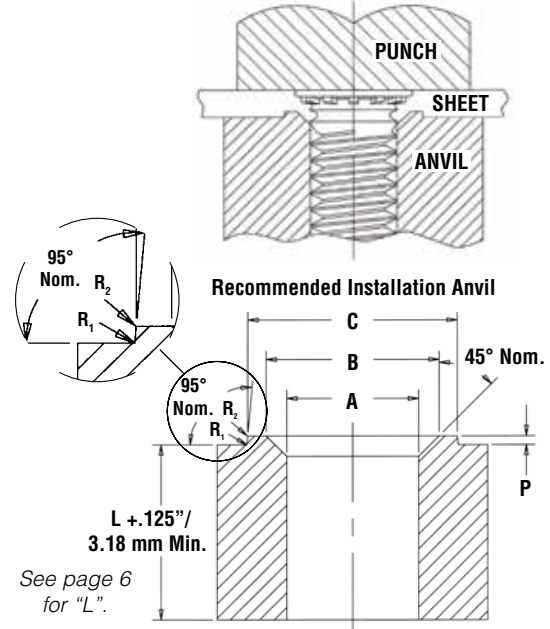

INSTALLATION - TYPES FHL™/FHL5™ STUDS

1. Prepare properly sized mounting hole in sheet. Do not perform any secondary operations such as deburring.
2. Insert stud through mounting hole (punch side) of sheet and into anvil hole.
3. With punch and anvil surfaces parallel, apply squeezing force to embed the head of the stud flush in the sheet. For sheets .060" / 1.51 mm and thicker, the anvil requires only a straight thru hole to accommodate the stud. For sheets less than .060" / 1.51 mm, the hole requires a countersink with dimension A at the top to provide for metal flow around the shank of the stud.

Tooling for sheet thicknesses less than .060" / 1.51 mm.

Tooling for sheet thicknesses .060" / 1.51 mm and greater.

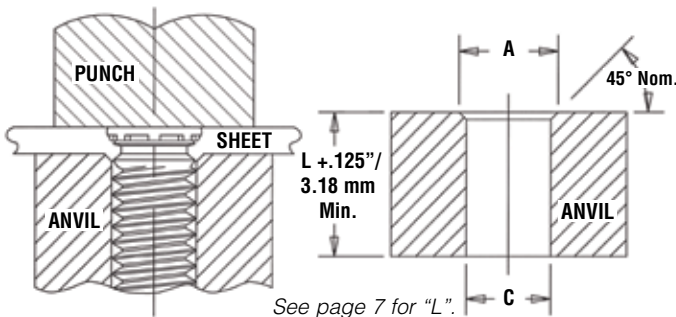

See page 7 for "L".

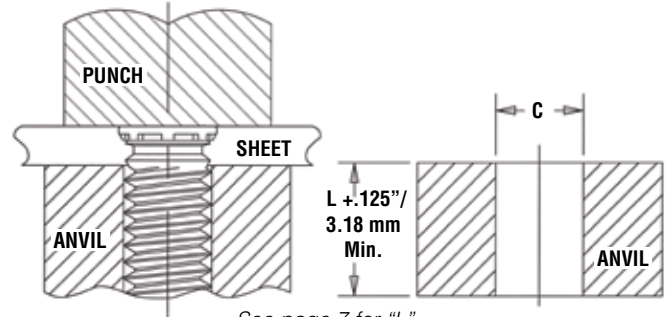

See page 7 for "L".

UNIFIED	Thread Code	Anvil Dimensions (in.)		Anvil Part No. For Sheets > .060"	Anvil Part No. For Sheets ≤ .059"	Punch Part Number
		A	C			
	256	.110-.114	.087-.090	8003313	8003297	975200997
	440	.136-.140	.113-.116	8003618	8003298	
	632	.162-.166	.139-.142	8003314	8003299	
	832	.188-.192	.165-.168	8003315	8003300	
	032	.216-.220	.191-.194	8003619	8003301	

METRIC	Thread Code	Anvil Dimensions (mm)		Anvil Part No. For Sheets > 1.51 mm	Anvil Part No. For Sheets ≤ 1.5 mm	Punch Part Number
		A	C			
	M2.5	3.1	2.53	8003316	8003302	975200997
	M3	3.6	3.03	8003317	8003303	
	M3.5	4.1	3.53	8003318	8003304	
	M4	4.6	4.03	8003620	8003305	
	M5	5.6	5.03	8003319	8003306	

SELF-CLINCHING STUDS AND PINS

INSTALLATION - TYPES TFH/TFHS NON-FLUSH STUDS

1. Prepare properly sized mounting hole in sheet. Do not perform any secondary operations such as deburring.
2. Insert stud through mounting hole (punch side) of sheet and into anvil hole.
3. With punch and anvil surfaces parallel, apply squeezing force until the punch contacts the sheet. When installed, the stud head is not flush but will protrude approximately $.025" / 0.64 \text{ mm}$. For sheets $.030" / 0.76 \text{ mm}$ and thicker, the anvil requires only a straight thru hole to accommodate the stud. For sheets less than $.030" / 0.76 \text{ mm}$ down to $.020" / 0.51 \text{ mm}$, the hole requires a countersink with dimension A at the top to provide for metal flow around the shank of the stud. The standard punch design below provides clearance for the stud head and reduces chances of over squeezing the head of the stud into the sheet metal.

Tooling for sheet thicknesses less than $.030" / 0.76 \text{ mm}$ down to $.020" / 0.51 \text{ mm}$.

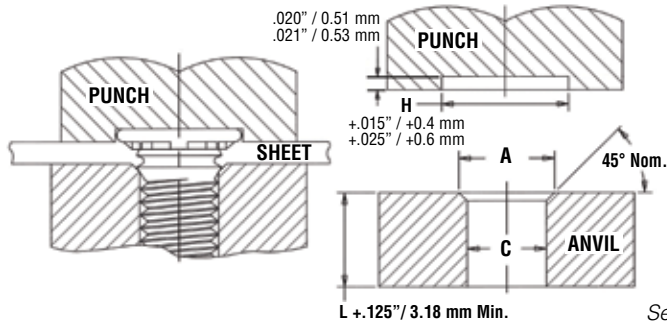

Tooling for sheet thicknesses $.030" / 0.76 \text{ mm}$ and greater.

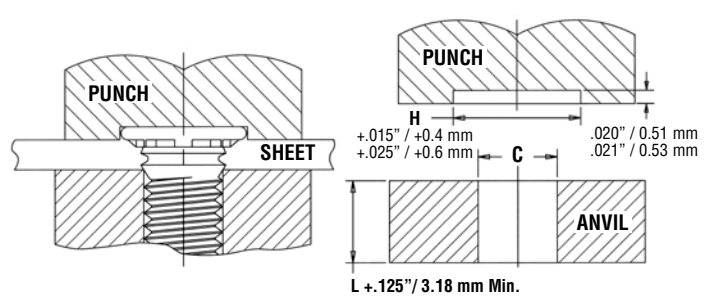

See page 8 for "L".

UNIFIED	Thread Code	Anvil Dimensions (in.)		Anvil Part No. For Sheets $> .030"$	Anvil Part No. For Sheets $.020" - .029"$	Punch Part Number
		A	C			
	256	.110-.114	.087-.090	970200005300	970200240300	970200235400
	440	.136-.140	.113-.116	970200006300	970200241300	970200236400
	632	.162-.166	.139-.142	970200007300	970200243300	970200237400
	832	.188-.192	.165-.168	970200008300	970200245300	970200238400
	032	.216-.220	.191-.194	970200009300	970200246300	970200239400
	0420	.295-.300	.250-.253	970200010300	970200249300	970200496400

METRIC	Thread Code	Anvil Dimensions (mm)		Anvil Part No. For Sheets $> 0.76 \text{ mm}$	Anvil Part No. For Sheets $0.51 - 0.75 \text{ mm}$	Punch Part Number
		A + 0.1	C + 0.08			
	M3	3.6	3.03	970200229300	970200242300	970200236400
	M3.5	4.1	3.53	970200007300	970200243300	970200237400
	M4	4.6	4.03	970200019300	970200244300	970200238400
	M5	5.6	5.03	970200020300	970200247300	970200239400
	M6	6.6	6.03	970200230300	970200248300	970200496400

INSTALLATION - TYPES HFH/HFHB/HFHS STUDS

1. Prepare properly sized mounting hole in sheet. Do not perform any secondary operations such as deburring.
2. Insert stud through mounting hole (punch side) of sheet and into anvil hole.
3. With punch and anvil surfaces parallel, apply squeezing force on the punch sufficient only to embed the ribs on the head of the stud into the sheet. The standard punch design provides clearance for the stud head and reduces chances of over squeezing.

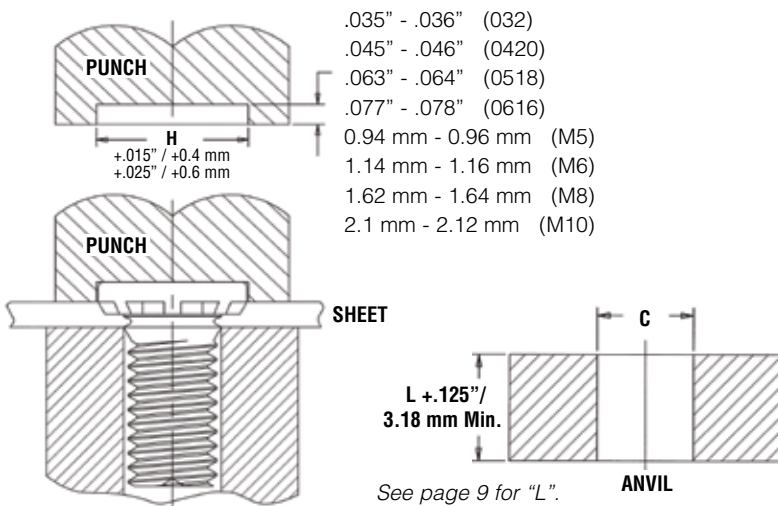

See page 9 for "L".

UNIFIED	Thread Code	Anvil Dimensions (in.)	Anvil Part Number	Punch Part Number
		C		
	032	.191 - .194	970200009300	970200311400
	0420	.250 - .253	970200010300	970200312400
	0518	.3125 - .3155	970200011300	970200313400
	0616	.375 - .378	970200004300	970200314400

METRIC	Thread Code	Anvil Dimensions (mm)	Anvil Part Number	Punch Part Number
		C + 0.08		
	M5	5.03	970200020300	970200311400
	M6	6.03	970200230300	970200312400
	M8	8.03	970200231300	970200313400
	M10	10.03	970200402300	970200491400

SELF-CLINCHING STUDS AND PINS

INSTALLATION - TYPE HFE™ STUDS

1. Prepare properly sized mounting hole in sheet. Do not perform any secondary operations such as deburring.
2. Insert stud through mounting hole (punch side) of sheet and into anvil hole.
3. With punch and anvil surfaces parallel, apply squeezing force on the punch sufficient only to embed the ribs on the head of the stud into the sheet. Note that for sheets $.060'' / 1.51 \text{ mm}$ and thicker, the anvil requires only a straight thru hole to accommodate the stud. For sheets less than $.060'' / 1.51 \text{ mm}$ to less than $.075'' / 1.9 \text{ mm}$, the hole requires a countersink with dimension A at the top to provide for metal flow around the shank of the stud.

Tooling for sheet thicknesses less than $.060'' / 1.51 \text{ mm}$ with #10 / M5 and $1/4'' / M6$ thread sizes and less than $.075'' / 1.9 \text{ mm}$ with $5/16'' / M8$ threads.

Tooling for sheet thicknesses $.060'' / 1.51 \text{ mm}$ and greater with #10 / M5 and $1/4'' / M6$ thread sizes and $.075'' / 1.9 \text{ mm}$ and greater with $5/16'' / M8$ threads.

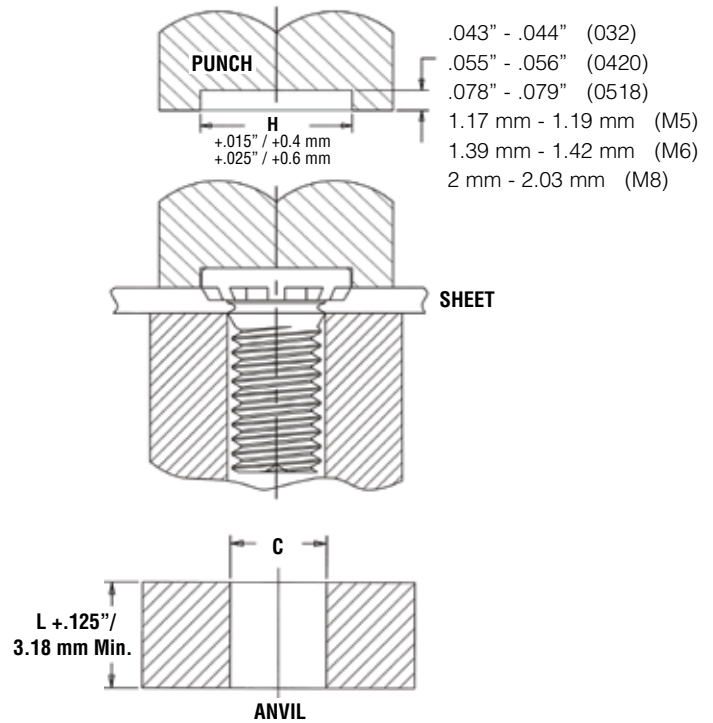
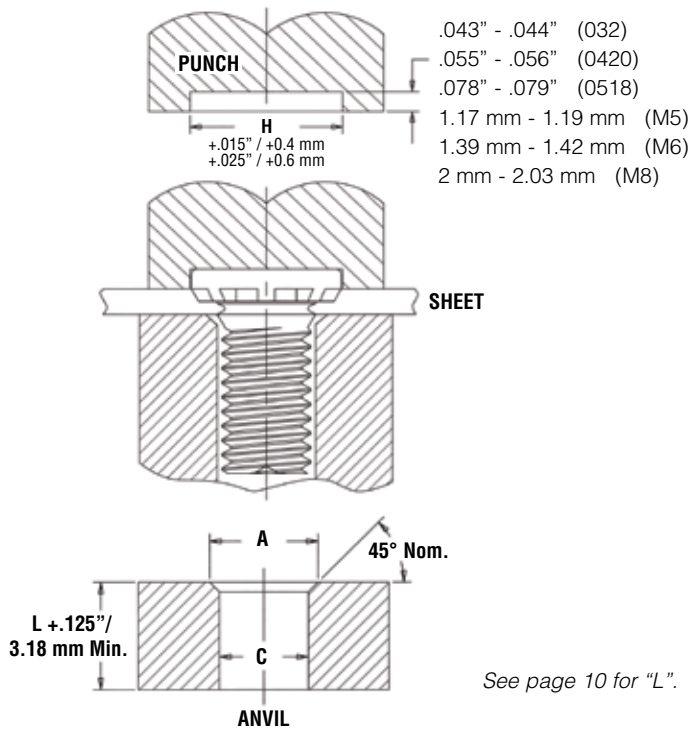

UNIFIED	Thread Code	Anvil Dimensions (in.)		Anvil Part No. For Sheets $> .060''$	Anvil Part No. For Sheets $.040'' - .059''$	Punch Part Number
		A	C			
	032	.216-.220	.191-.194	970200009300	970200246300	8003707
	0420	.295-.300	.250-.253	970200010300	8003702	8003708
				For Sheets $> .075''$	For Sheets $.060'' - .075''$	
	0518	.334-.338	.3125-.3155	970200011300	8003703	8003709

METRIC	Thread Code	Anvil Dimensions (mm)		Anvil Part No. For Sheets $> 1.51 \text{ mm}$	Anvil Part No. For Sheets $1 \text{ mm} - 1.5 \text{ mm}$	Punch Part Number
		A + 0.1	C + 0.08			
	M5	5.6	5.03	970200020300	8003704	8003710
	M6	6.6	6.03	970200230300	8003705	8003711
				For Sheets $> 21.9 \text{ mm}$	For Sheets $1.5 - 1.9 \text{ mm}$	
	M8	8.6	8.03	970200231300	8003706	8003712

SELF-CLINCHING STUDS AND PINS

INSTALLATION - TYPES HFG8™/HF109™ STUDS

1. Prepare properly sized mounting hole in sheet. Do not perform any secondary operations such as deburring.
2. Insert stud through mounting hole (punch side) of sheet and into anvil hole.
3. With punch and anvil surfaces parallel, apply squeezing force on the punch sufficient only to embed the ribs on the head of the stud into the sheet. Note that for sheets .060" / 1.51 mm and thicker, the anvil requires only a straight thru hole to accommodate the stud. For sheets less than .060" / 1.51 mm to less than .075" / 1.9 mm, the hole requires a countersink with dimension A at the top to provide for metal flow around the shank of the stud.

Tooling for sheet thicknesses less than .060" / 1.51 mm with #10 / M5 and 1/4" / M6 thread sizes and less than .075" / 1.9 mm with 5/16" / M8 threads.

Tooling for sheet thicknesses .060" / 1.51 mm and greater with #10 / M5 and 1/4" / M6 thread sizes and .075" / 1.9 mm and greater with 5/16" / M8 threads.

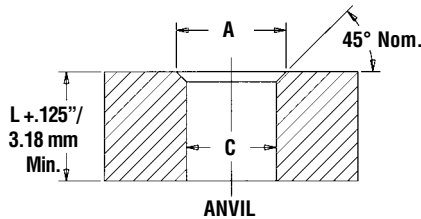
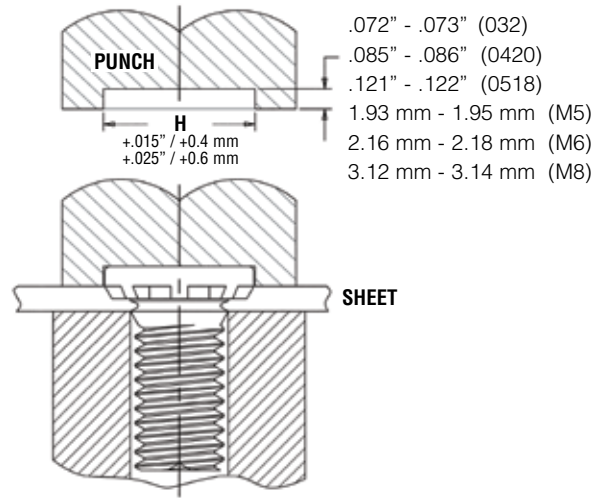
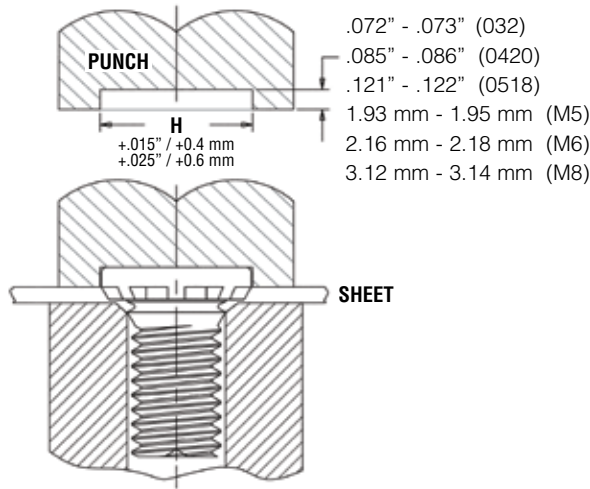

See page 11 for "L".

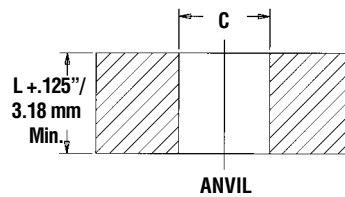

UNIFIED	Thread Code	Anvil Dimensions (in.)		Anvil Part Number (Standard Sheet)	Anvil Part Number (Thin Sheet)	Punch Part Number
		A	C			
	032	.216 - .220	.191 - .194	970200009300	970200246300	8014456
	0420	.273 - .278	.250 - .253	970200010300	8003702	8014458
	0518	.334 - .338	.3125 - .3155	970200011300	8003703	8014460

METRIC	Thread Code	Anvil Dimensions (mm)		Anvil Part Number (Standard Sheet)	Anvil Part Number (Thin Sheet)	Punch Part Number
		A + 0.1	C + 0.08			
	M5	5.6	5.03	970200020300	8003704	8014457
	M6	6.6	6.03	970200230300	8003705	8014459
	M8	8.6	8.03	970200231300	8003706	8014461

SELF-CLINCHING STUDS AND PINS

INSTALLATION - TYPES FH/FHS/FHA PINS

1. Prepare properly sized mounting hole in sheet. Do not perform any secondary operations such as deburring.
2. Insert pin through mounting hole (punch side) of sheet and into anvil hole.
3. With punch and anvil surfaces parallel, apply squeezing force to embed the head of the pin flush in the sheet. In most cases, when using sheets .060" / 1.51 mm and thicker, the anvil requires only a straight thru hole to accommodate the pin (see illustrations below for details). For sheets less than .060" / 1.51 mm, the hole requires a countersink with dimension A at the top to provide for metal flow around the shank of the pin.

Tooling for sheet thicknesses less than .060" / 1.52 mm with 073 thru 173 / 3 mm thru 5 mm pin diameter codes and for sheet thicknesses less than .093 / 2.36 mm with 207 thru 223 pin diameter codes.

Tooling for sheet thicknesses greater than .060" / 1.52 mm with 073 thru 173 / 3 mm thru 5 mm pin diameter codes and for sheet thicknesses greater than .093" / 2.36 mm with 207 thru 281 pin diameter codes.

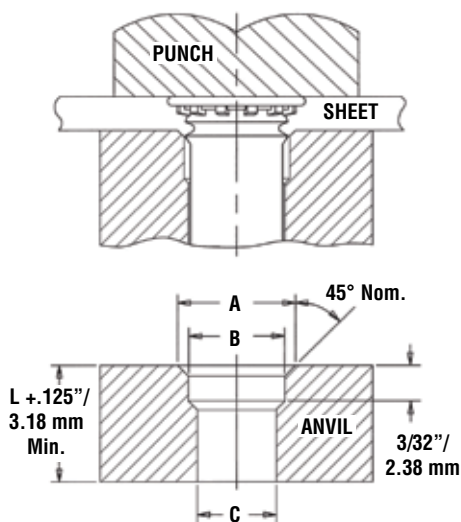

See page 12 for "L".

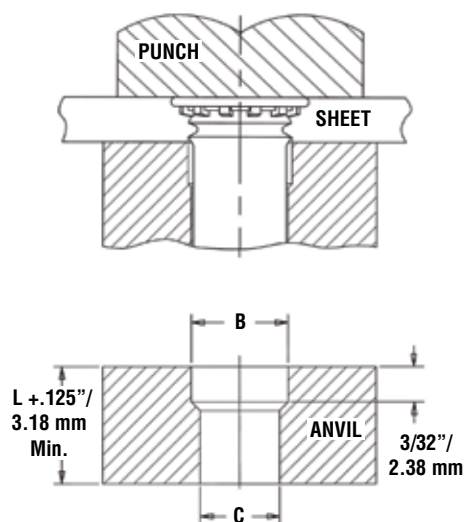

UNIFIED	Pin Dia. Code	Anvil Dimensions (in.)		
		A ±.004 - .000	B ±.002	C ±.002
	073	.116	.089	.078
	084	.133	.103	.089
	094	.162	.115	.099
	103	.166	.122	.109
	106	.168	.129	.111
	116	.191	.141	.121
	120	.191	.141	.125
	137	.215	.161	.144
	141	.216	.167	.147
	160	.244	.193	.166
	167	.244	.193	.172
	173	.250	.201	.180
	207	.286	.240	.213
	215	.290	.254	.221
	223	.298	.254	.228
	273	.325	.316	.277
	281	.320	.316	.290

METRIC	Pin Dia. Code	Anvil Dimensions (mm)		
		A ±0.1	B ±0.05	C ±0.05
	3MM	4.9	3.61	3.1
	4MM	5.44	4.19	4.1
	5MM	6.93	5.61	5.1

SELF-CLINCHING STUDS AND PINS

INSTALLATION - TYPE SGPC™ SWAGING COLLAR STUDS 1.

1. Prepare properly sized mounting hole in sheet.
2. Insert fastener through mounting hole (punch side) as shown in drawing.
3. With installation punch and anvil surfaces parallel, apply squeezing force until the punch pushes over the protruding knurls of the stud.

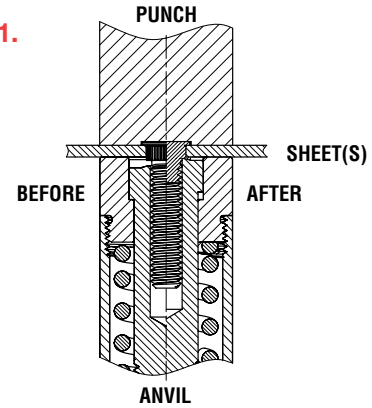

UNIFIED	Thread Code	Punch Dimensions (in.)		Punch Part Number	Anvil Dimensions (in.)		Anvil Part Number
		A +.004 - .000	B +.000 - .001		C +.001	P +.000 - .002	
	256	.209	.019	8015111	.087	.014	8016983
440	.248	.022	8015112	.113	.014	8016984	
632	.276	.022	8015113	.139	.014	8016985	
832	.299	.022	8015114	.165	.014	8016986	
032	.327	.022	8015115	.191	.014	8016987	
0420	.386	.026	8015116	.251	.014	8016988	

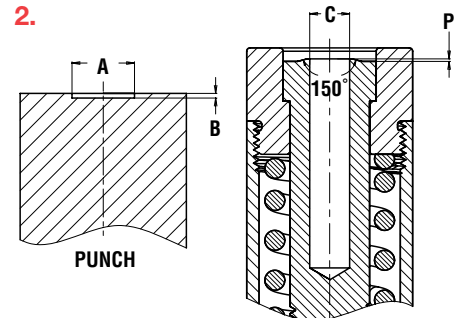

METRIC	Thread Code	Punch Dimensions (mm)		Punch Part Number	Anvil Dimensions (mm)		Anvil Part Number
		A +0.1	B -0.025		C +0.025	P -0.05	
	M2.5	5.5	0.47	8015117	2.53	0.35	8016989
M3	6.5	0.57	8015118	3.03	0.35	8016990	
M4	7.5	0.57	8015119	4.03	0.35	8016991	
M5	8.5	0.57	8015120	5.03	0.35	8016992	
M6	9.5	0.67	8015121	6.03	0.35	8016993	

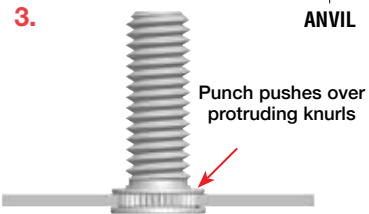

NOTE: For panel design information, go to http://www.pemnet.com/SGPC_Panel_Designs.pdf

INSTALLATION - TYPES TPS™/TP4™/TPXS™ PILOT PINS

1. Prepare properly sized mounting hole in sheet. Do not perform any secondary operations such as deburring.
2. Insert pin through mounting hole (punch side) of sheet and into anvil hole.
3. With punch and anvil surfaces parallel, apply squeezing force to embed the head of the pin flush in the sheet.

UNIFIED	Pin Dia. Code	Test Sheet Thickness (in.)	Anvil Dimensions (in.)		Anvil Part Number	Punch Part Number
			A ±.002	C ±.002		
	125	.040 - .060 Over .060	.160 (1)	.130	8003284 8003278	975200048
187	.040 - .065 Over .065	.220 (1)	.192	8003285 8003279		
250	.040 - .075 Over .075	.285 (1)	.255	8003286 8003280		

METRIC	Pin Dia. Code	Test Sheet Thickness (mm)	Anvil Dimensions (mm)		Anvil Part Number	Punch Part Number
			A ±0.05	C ±0.05		
	3MM	1 - 1.7 Over 1.7	3.88 (1)	3.11	8008096 8008095	975200048
4MM	1 - 1.7 Over 1.7	4.88 (1)	4.11	8003287 8003281		
5MM	1 - 1.8 Over 1.8	5.89 (1)	5.13	8003288 8003282		
6MM	1 - 1.9 Over 1.9	6.89 (1)	6.12	8003289 8003283		

(1) Chamfered anvil not required.

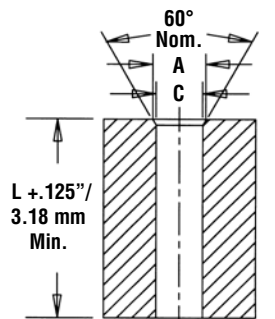

Recommended tooling when a chamfered anvil is required.

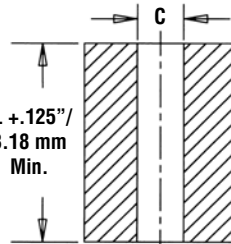

Recommended tooling when a chamfered anvil is not required.

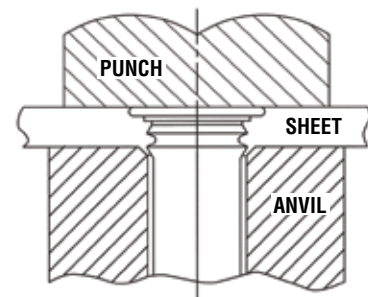

SELF-CLINCHING STUDS AND PINS

Installation values are for general reference only. Actual set up and installation should be performed using the visual indication method described in this literature. Other performance values reported are averages when all proper installation parameters and procedures are followed. Variations in mounting hole size, sheet material, and installation procedure may affect performance. Performance testing this product in your application is recommended. We will be happy to provide technical assistance and/or samples for this purpose.

PERFORMANCE DATA - TYPES FH/FHS FLUSH-HEAD STUDS

UNIFIED	Thread Code	Max. Nut Tightening Torque (in. lbs.)	Type	Test Sheet Thickness & Material	Sheet Hardness HRB	Installation (lbs.)	Pushout (lbs.)	Torque-out (in. lbs.)	Pull Thru (lbs.)
	256	2.3	FH	.062" Aluminum	29	2000	100	5	425
			FHS	.062" Aluminum	29	2000	100	4.5	300
			FH	.060" Steel	59	2500	180	5	425
			FHS	.060" Steel	59	2500	180	4.5	300
	440	5	FH	.064" Aluminum	29	3800	170	10	650
			FHS	.064" Aluminum	29	3200	170	8	500
			FH	.060" Steel	59	4300	275	10	650
			FHS	.060" Steel	59	4700	275	8	500
	632	9	FH	.064" Aluminum	29	3800	180	17	850
FHS			.064" Aluminum	29	3500	180	16	775	
FH			.060" Steel	59	4700	300	20	850	
FHS			.060" Steel	59	5000	300	16	775	
832	17	FH	.064" Aluminum	29	4800	220	28	1000	
		FHS	.064" Aluminum	29	4500	220	28	940	
		FH	.060" Steel	59	6800	375	40	1270	
		FHS	.060" Steel	59	5500	375	28	1130	
032	27	FH	.064" Aluminum	29	5500	270	30	1220	
		FHS	.064" Aluminum	29	5500	270	30	1220	
024	24	FH	.060" Steel	59	7500	450	60	1410	
		FHS	.060" Steel	59	6800	450	50	1410	
0420	58	FH	.093" Aluminum	28	6500	310	65	2300	
		FHS	.093" Aluminum	28	6500	310	65	2100	
		FH	.088" Steel	46	9500	575	100	2550	
		FHS	.088" Steel	46	10000	575	100	2550	
0518	120	FH	.093" Aluminum	28	6500	430	100	2260	
		FHS	.093" Aluminum	28	6700	430	100	2260	
		FH	.093" Steel	46	10000	650	175	3475	
		FHS	.093" Steel	46	11200	650	175	3120	

METRIC	Thread Code	Max. Nut Tightening Torque (N•m)	Type	Test Sheet Thickness & Material	Sheet Hardness HRB	Installation (kN)	Pushout (N)	Torque-out (N•m)	Pull Thru (N)
	M2.5	0.41	FH	1.6 mm Aluminum	29	8.9	465	1.0	2600
			FHS	1.6 mm Aluminum	29	11.6	465	0.8	1820
			FH	1.5 mm Steel	59	11.1	740	1.0	2800
			FHS	1.5 mm Steel	59	13.8	740	0.8	1820
	M3	0.74	FH	1.6 mm Aluminum	29	12.9	600	1.7	3150
			FHS	1.6 mm Aluminum	29	12.9	600	1.3	2570
			FH	1.5 mm Steel	59	14.7	820	1.7	3840
			FHS	1.5 mm Steel	59	14.7	820	1.3	2440
	M3.5	1.15	FH	1.6 mm Aluminum	29	15.6	800	1.7	3780
FHS			1.6 mm Aluminum	29	15.6	800	1.7	3445	
FH			1.5 mm Steel	59	22.3	1335	2.8	3780	
FHS			1.5 mm Steel	59	22.3	1335	2.0	3445	
M4	1.7	FH	1.6 mm Aluminum	29	20	975	2.9	4448	
		FHS	1.6 mm Aluminum	29	22.3	975	2.9	4180	
		FH	1.5 mm Steel	59	28.9	1780	4.2	5650	
		FHS	1.5 mm Steel	59	26.7	1780	2.9	4775	
M5	3.5	FH	1.6 mm Aluminum	29	24.5	1070	3.5	5170	
		FHS	1.6 mm Aluminum	29	24.5	1070	3.5	4760	
		FH	1.5 mm Steel	59	33.4	2000	6.5	6270	
		FHS	1.5 mm Steel	59	32.5	2000	6.3	6000	
M6	5.9	FH	2.4 mm Aluminum	28	28.9	1660	7.3	10200	
		FHS	2.4 mm Aluminum	28	28.9	1660	7.3	9090	
		FH	2.2 mm Steel	46	44.5	2560	11.3	11300	
		FHS	2.2 mm Steel	46	44.5	2560	10.1	10600	
M8	14.2	FH	2.4 mm Aluminum	28	29.8	1910	11.3	10500	
		FHS	2.4 mm Aluminum	28	29.8	1910	11.3	9540	
		FH	2.4 mm Steel	46	44.5	2890	19.2	15450	
		FHS	2.4 mm Steel	46	49.8	2890	17.5	13630	

SELF-CLINCHING STUDS AND PINS

PERFORMANCE DATA - TYPE FHA FLUSH-HEAD STUDS

UNIFIED	Thread Code	Max. Nut Tightening Torque (in. lbs.)	Type	Test Sheet Thickness & Material	Sheet Hardness HR15T	Installation (lbs.)	Pushout (lbs.)	Torque-out (in. lbs.)	Pull Thru (lbs.)
	440	3	FHA	.061" 5052-H34 Aluminum	75.1	2500	155	4	270
	632	5.4	FHA	.061" 5052-H34 Aluminum	75.1	2600	180	8	380
	832	10.2	FHA	.061" 5052-H34 Aluminum	73	3200	190	15	500
	032	16.2	FHA	.061" 5052-H34 Aluminum	75	3200	220	28	600
	0420	34.8	FHA	.061" 5052-H34 Aluminum	75	5500	300	55	1050

METRIC	Thread Code	Max. Nut Tightening Torque (N•m)	Type	Test Sheet Thickness & Material	Sheet Hardness HR15T	Installation (kN)	Pushout (N)	Torque-out (N•m)	Pull Thru (N)
	M3	0.44	FHA	1.55 mm 5052-H34 Aluminum	74	10.7	575	0.5	1500
	M4	1.02	FHA	1.55 mm 5052-H34 Aluminum	75	14.3	775	1.35	2000
	M5	2.1	FHA	1.55 mm 5052-H34 Aluminum	75	15.2	900	2.6	2500
	M6	3.54	FHA	1.55 mm 5052-H34 Aluminum	75.1	24.5	1500	5.3	4500

PERFORMANCE DATA - TYPE FH4™ STUDS⁽¹⁾

UNIFIED	Thread Code	Max. Nut Tightening Torque (in. lbs.)	Test Sheet Thickness and Material (2)	Sheet Hardness HRB	Installation (lbs.)	Pushout (lbs.)	Torque-out (in. lbs.)	Pull Thru (lbs.)
	440	6	.060" Stainless Steel	87	9000	450	16	800
	632	11	.060" Stainless Steel	87	9500	540	27	1350
	832	21	.060" Stainless Steel	86	11200	780	58	1800
	032	33	.060" Stainless Steel	86	12000	800	95	2250
	0420	70	.060" Stainless Steel	88	23000	1600	156	3900

METRIC	Thread Code	Max. Nut Tightening Torque (N•m)	Test Sheet Thickness and Material (2)	Sheet Hardness HRB	Installation (kN)	Pushout (N)	Torque-out (N•m)	Pull Thru (N)
	M3	.9	1.5 mm Stainless Steel	87	40	2220	1.8	3500
	M4	2.1	1.5 mm Stainless Steel	86	50	3210	6.5	8000
	M5	4.3	1.5 mm Stainless Steel	86	53	3560	10.7	10000
	M6	7.2	1.5 mm Stainless Steel	88	71	4200	15.9	14900

PERFORMANCE DATA - TYPE FHP™ STUDS⁽¹⁾

UNIFIED	Thread Code	Max. Nut Tightening Torque (in. lbs.)	Test Sheet Thickness and Material (2)	Sheet Hardness HRB	Installation (lbs.)	Pushout (lbs.)	Torque-out (in. lbs.)	Pull Thru (lbs.)
	440	6	.045" Stainless Steel	86	9000	520	10.6	605
	632	11	.045" Stainless Steel	86	9500	670	19.5	940
	832	21	.045" Stainless Steel	86	11200	785	37.5	1415
	032	33	.045" Stainless Steel	86	12000	800	59.5	1500

METRIC	Thread Code	Max. Nut Tightening Torque (N•m)	Test Sheet Thickness and Material (2)	Sheet Hardness HRB	Installation (kN)	Pushout (N)	Torque-out (N•m)	Pull Thru (N)
	M4	2.1	1.14 mm Stainless Steel	86	50	3000	3.9	6000
	M5	4.3	1.14 mm Stainless Steel	86	53	3560	7.35	7320

(1) Performance values shown are typical for fasteners properly installed using raised ring tooling in good condition. We recommend replacing installation tooling when the height of the "P" falls out of tolerance (see page 17). Reductions in performance may occur as the height of the protrusion wears. Variations in hole preparation, installation force, and sheet material type, thickness, and hardness will affect both performance and tooling life.

(2) Performance may be reduced for studs installed into thicker sheets.

SELF-CLINCHING STUDS AND PINS

PERFORMANCE DATA - TYPES FHL™/FHLS™ STUDS

UNIFIED	Thread Code	Max. Nut Tightening Torque (in. lbs.)	Type	Test Sheet Thickness and Material	Sheet Hardness HRB	Installation (lbs.)	Pushout (lbs.)	Torque-out (in. lbs.)	Pull Thru (lbs.)	Pull Thru Test Bushing Hole Size (in.)
	256	2.3	FHL / FHLS	.047" Aluminum	33	700	55	4	230	.106
		2.3	FHL / FHLS	.045" Steel	54	1200	85	8	425	.106
	440	4.0	FHL / FHLS	.047" Aluminum	33	1000	60	5	300	.132
		5.0	FHL / FHLS	.045" Steel	54	1200	105	11	580	.132
	632	5.4	FHL / FHLS	.047" Aluminum	33	1000	65	6.5	325	.158
		9.0	FHL / FHLS	.045" Steel	54	1500	110	15	650	.158
	832	6.9	FHL / FHLS	.047" Aluminum	33	1200	80	9	350	.184
		15.2	FHL / FHLS	.045" Steel	54	1500	125	18	740	.184
	032	9.7	FHL / FHLS	.047" Aluminum	33	2500	115	18	395	.210
19.4		FHL / FHLS	.045" Steel	54	4500	210	38	800	.210	

METRIC	Thread Code	Max. Nut Tightening Torque (N•m)	Type	Test Sheet Thickness and Material	Sheet Hardness HRB	Installation (kN)	Pushout (N)	Torque-out (N•m)	Pull Thru (N)	Pull Thru Test Bushing Hole Size (mm)
	M2.5	0.41	FHL / FHLS	1.2 mm Aluminum	33	3.1	285	0.55	1200	3
		0.41	FHL / FHLS	1.1 mm Steel	54	5.3	450	1.1	2250	3
	M3	0.46	FHL / FHLS	1.2 mm Aluminum	33	4.4	285	0.65	1300	3.5
		0.74	FHL / FHLS	1.1 mm Steel	54	5.3	475	1.25	2500	3.5
	M3.5	0.58	FHL / FHLS	1.2 mm Aluminum	33	4.4	290	0.76	1400	4
		1.15	FHL / FHLS	1.1 mm Steel	54	6.6	500	1.75	2800	4
	M4	0.75	FHL / FHLS	1.2 mm Aluminum	33	5.3	365	1.1	1550	4.5
		1.7	FHL / FHLS	1.1 mm Steel	54	6.6	550	2.1	3300	4.5
	M5	1.11	FHL / FHLS	1.2 mm Aluminum	33	11.1	530	2.2	1850	5.5
2.25		FHL / FHLS	1.1 mm Steel	54	20	1000	4.4	3750	5.5	

PERFORMANCE DATA - TYPES TFH/TFHS NON-FLUSH STUDS

UNIFIED	Thread Code	Max. Nut Tightening Torque (in. lbs.)	Type	Test Sheet Thickness and Material	Sheet Hardness HRB	Installation (lbs.) (1)	Pushout (lbs.)	Torque-out (in. lbs.)
	440	5	TFH	.020" Aluminum	28	1300	45	7
			TFHS	.020" Aluminum	28	1200	45	7
			TFH	.023" Steel	52	2800	100	8
			TFHS	.025" Steel	52	1500	100	8
	632	9	TFH	.020" Aluminum	28	2100	50	8
			TFHS	.020" Aluminum	28	1500	50	8
			TFH	.023" Steel	52	2500	110	16
			TFHS	.025" Steel	52	2500	110	16
	832	17	TFH	.020" Aluminum	28	2100	60	10
TFHS			.020" Aluminum	28	2200	60	11	
TFH			.023" Steel	52	3100	120	26	
TFHS			.025" Steel	52	2700	120	26	
024	24	TFH	.020" Aluminum	28	2300	65	14	
		TFHS	.020" Aluminum	28	2500	65	14	
032	27	TFH	.023" Steel	52	3700	150	30	
		TFHS	.025" Steel	52	3000	130	28	

METRIC	Thread Code	Max. Nut Tightening Torque (N•m)	Type	Test Sheet Thickness and Material	Sheet Hardness HRB	Installation (kN) (1)	Pushout (N)	Torque-out (N•m)
	M3	0.74	TFH	0.5 mm Aluminum	28	5.8	195	0.6
			TFHS	0.5 mm Aluminum	28	5.3	195	0.6
			TFH	0.6 mm Steel	52	12.5	300	1
			TFHS	0.6 mm Steel	52	6.7	300	1
	M4	1.7	TFH	0.5 mm Aluminum	28	12.5	250	0.7
			TFHS	0.5 mm Aluminum	28	9.8	250	0.7
			TFH	0.6 mm Steel	52	17.8	500	2.5
			TFHS	0.6 mm Steel	52	13.4	500	2.5
	M5	3.5	TFH	0.5 mm Aluminum	28	15.6	270	1.3
TFHS			0.5 mm Aluminum	28	13.4	270	1.3	
TFH			0.6 mm Steel	52	26.7	670	3	
TFHS			0.6 mm Steel	52	17.8	670	3	

(1) Installation controlled by proper cavity depth in punch.

SELF-CLINCHING STUDS AND PINS

PERFORMANCE DATA - TYPE HFE™ STUDS

UNIFIED	Thread Code	Max. Nut Tightening Torque (ft. lbs.)	Test Sheet Thickness and Material (in.)	Sheet Hardness HRB	Installation (lbs.) (1)	Pushout (lbs.)	Torque-out (in. lbs.)	Tensile Strength (lbs.) (2)	Pull Thru (lbs.)	Test Bushing Hole Size For Pull Thru Tests
	032	3.25	.040" Aluminum	27	7500	170	60	2400	1900	.279
	.040" Cold-rolled Steel		67	9500	300	60	2400	2200		
0420	8	.040" Aluminum	27	8000	180	120	3820	3200	.335	
		.040" Cold-rolled Steel	67	13500	340	130	3820	3600		
0518	16	.060" Aluminum	22	9000	275	240	6280	6000	.407	
		.060" Cold-rolled Steel	65	15500	575	290	6280	6400		

METRIC	Thread Code	Max. Nut Tightening Torque (N•m)	Test Sheet Thickness and Material (mm)	Sheet Hardness HRB	Installation (kN) (1)	Pushout (N)	Torque-out (N•m)	Tensile Strength (kN) (2)	Pull Thru (kN)	Test Bushing Hole Size For Pull Thru Tests
	M5	4.4	1 mm Aluminum	27	37.7	690	8.1	12.8	9.7	7.4
1 mm Cold-rolled Steel			67	51.1	1350	8.1	12.8	10.6		
M6	10	1 mm Aluminum	27	39	750	11.8	18.1	14.2	8.2	
		1 mm Cold-rolled Steel	67	60	1400	14.4	18.1	15.5		
M8	21.7	1.5 mm Aluminum	22	42	1230	23.5	32.9	25	10.3	
		1.5 mm Cold-rolled Steel	65	71.1	2400	33.9	32.9	27.5		

PERFORMANCE DATA - TYPES HFH/HFHS/HFHB STUDS

UNIFIED	Thread Code	Type	Max. Nut Tightening Torque (ft. lbs.)	Test Sheet Thickness and Material	Sheet Hardness HRB	Installation (lbs.) (1)	Pushout (lbs.)	Torque-out (ft. lbs.)	Tensile Strength (lbs.) (2)
	032		HFH	3.25	.060" Aluminum	15	3000	180	4
HFH			3.25	.060" Steel	65	6000	375	5	2400
HFHS			3.25	.050" Aluminum	38	3000	180	4	1500
HFHS			3.25	.058" Steel	52	4500	325	4	1500
HFHB			2.56	.061" Copper CDA-110	28	3400	150	2.9	1200
0420		HFH	8	.060" Aluminum	43	5500	285	11	3820
		HFH	8	.060" Steel	59	7000	480	11	3820
		HFHS	8	.064" Aluminum	32	4000	285	8	2385
		HFHS	8	.072" Steel	43	6500	480	8	2385
		HFHB	4.35	.061" Copper CDA-110	28	6000	380	5	1908
0518		HFH	16	.091" Aluminum	39	8000	380	22	6280
		HFH	16	.090" Steel	58	10000	590	22	6280
		HFHS	16	.087" Aluminum	41	5500	380	15	3930
		HFHS	16	.099" Steel	44	7500	590	15	3930
		HFHB	10.55	.126" Copper CDA-110	32	7500	500	11	3140
0616		HFH	27	.091" Aluminum	39	12000	550	25	9300
		HFH	27	.090" Steel	58	18000	780	36	9300
		HFHS	27	.123" Aluminum	44	10000	560	25	5810
		HFHS	27	.099" Steel	44	13000	780	25	5810
		HFHB	21	.126" Copper CDA-110	32	12000	560	18	4650

METRIC	Thread Code	Type	Max. Nut Tightening Torque (N•m)	Test Sheet Thickness and Material	Sheet Hardness HRB	Installation (kN) (1)	Pushout (N)	Torque-out (N•m)	Tensile Strength (kN) (2)
	M5		HFH	4.4	1.5 mm Aluminum	15	13	800	5.4
HFH			4.4	1.5 mm Steel	65	26	1500	7.6	12.8
HFHS			4.4	1.62 mm Aluminum	35	12.4	800	5.4	7.3
HFHS			4.4	1.47 mm Steel	54	21.7	1500	6.4	7.3
HFHB			3.47	1.5 mm Copper CDA-110	28	15.6	1115	3.4	5.9
M6		HFH	10	1.5 mm Aluminum	43	29	1270	14	18.1
		HFH	10	1.5 mm Steel	59	33	1750	14	18.1
		HFHS	10	1.62 mm Aluminum	35	15.4	1270	11	10.3
		HFHS	10	1.6 mm Steel	45	24.6	1750	11	10.3
		HFHB	5.9	1.5 mm Copper CDA-110	28	25.3	1600	6.7	8.3
M8		HFH	21.7	2.3 mm Aluminum	39	35.6	1700	30	32.9
		HFH	21.7	2.3 mm Steel	58	44.5	2200	30	32.9
		HFHS	21.7	2.23 mm Aluminum	44	24.4	1700	20	18.8
		HFHS	21.7	2.48 mm Steel	43	37.8	2100	20	18.8
		HFHB	14.3	3.2 mm Copper CDA-110	32	33	2250	15.3	15.1
M10		HFH	36.6	2.3 mm Aluminum	39	53.3	2445	36	52.2
		HFH	36.6	2.3 mm Steel	58	80	3470	49	52.2
		HFHS	36.6	2.3 mm Aluminum	44	44.4	2445	36	29.9
		HFHS	36.6	2.3 mm Steel	44	57.7	3470	36	29.9
		HFHB	28.5	3.2 mm Copper CDA-110	32	53.3	2500	25	24

(1) Installation controlled by proper cavity depth in punch.
 (2) Head size is adequate to ensure failure in threaded area.



SELF-CLINCHING STUDS AND PINS

PERFORMANCE DATA - TYPES HFG8™ AND HF109™ HIGH TENSILE STRENGTH STUDS

UNIFIED	Thread Code	Max. Nut Tightening Torque (ft. lbs.)	Tensile Strength (lbs.)	Test Sheet Material	Sheet Hardness HRB	Installation (lbs.) (1)	Pushout (lbs.)	Torque-out (ft. lbs.)	Test Sheet Material	Sheet Hardness HRB	Installation (lbs.) (1)	Pushout (lbs.)	Torque-out (ft. lbs.)
	032	5.0	3000	.047" HSLA Steel	85.5	14000	483	6.2	.040" Cold-rolled Steel	45.0	9900	249	5.9
0420	10.4	4750	.047" HSLA Steel	85.7	21400	592	11.5	.040" Cold-rolled Steel	45.0	14100	248	11.5	
0518	21.5	7850	.060" HSLA Steel	84.9	32600	667	25.6	.060" Cold-rolled Steel	55.2	19100	447	25.2	

METRIC	Thread Code	Max. Nut Tightening Torque (N•m)	Tensile Strength (kN)	Test Sheet Material	Sheet Hardness HRB	Installation (kN) (1)	Pushout (N)	Torque-out (N•m)	Test Sheet Material	Sheet Hardness HRB	Installation (kN) (1)	Pushout (N)	Torque-out (N•m)
	M5	7.8	14.8	1.2 mm HSLA Steel	86.1	60.1	2084	9	1 mm Cold-rolled Steel	45.3	43.2	978	9
M6	13.2	20.9	1.2 mm HSLA Steel	85.6	90	2454	15.6	1 mm Cold-rolled Steel	45.5	60	1072	14.4	
M8	32	38.1	1.5 mm HSLA Steel	84	145	3026	38.4	1.5 mm Cold-rolled Steel	55	85	1992	37.7	

(1) Installation controlled by proper cavity depth in punch.

PERFORMANCE DATA - TYPE SGPC™ SWAGING COLLAR STUDS

UNIFIED	Thread Code	Max. Rec. Tightening Torque For Mating Nut (in. lbs.)	Test Sheet Material			
			Single sheet of .039" 300 Series Stainless Steel			
			Installation (lbs.)	Pushout (lbs.)	Torque-out (in. lbs.)	Pull-thru (lbs.)
256	2.3	4000	425	5.2	415	
440	5	5000	450	8	512	
632	9	5500	460	15.8	811	
832	17	6500	480	29.3	1133	
032	27	7300	545	42.8	1273	
0420	58	10000	565	76.7	1721	

METRIC	Thread Code	Max. Rec. Tightening Torque For Mating Nut (N•m)	Test Sheet Material			
			Single sheet of 1 mm 300 Series Stainless Steel			
			Installation (kN)	Pushout (N)	Torque-out (N•m)	Pull-thru (N)
M2.5	0.41	20.1	2546	0.86	2561	
M3	0.74	21.8	2051	1.35	2851	
M4	1.7	28.5	2396	2.66	4000	
M5	3.5	35.6	3200	5.96	4284	
M6	5.9	42.3	3262	9.19	6311	

PERFORMANCE DATA - TYPE TPS™ PILOT PINS

UNIFIED	Pin Dia. Code	Test Sheet Material	Sheet Hardness HRB	Installation (lbs.)	Pushout (lbs.)
	125	Aluminum	20	4500	150
Steel		62	6500	250	
187	Aluminum	18	6500	230	
	Steel	60	8000	400	
250	Aluminum	18	7000	270	
	Steel	62	9000	500	

METRIC	Pin Dia. Code	Test Sheet Material	Sheet Hardness HRB	Installation (kN)	Pushout (kN)
	3MM	Aluminum	22	12	0.56
Steel		65	22	0.98	
4MM	Aluminum	19	22	0.89	
	Steel	66	26.4	1.54	
5MM	Aluminum	18	28.6	1.01	
	Steel	60	35.2	1.76	
6MM	Aluminum	18	30.8	1.1	
	Steel	62	39.6	2.1	

SELF-CLINCHING STUDS AND PINS

PERFORMANCE DATA - TYPE TP4™ PILOT PINS

UNIFIED	Pin Dia. Code	Test Sheet Material	Installation (lbs.)	Pushout (lbs.)
	125	300 Series Stainless Steel	8000	350
	187	300 Series Stainless Steel	12000	570
	250	300 Series Stainless Steel	14000	650

METRIC	Pin Dia. Code	Test Sheet Material	Installation (kN)	Pushout (N)
	3MM	300 Series Stainless Steel	35	1556
	4MM	300 Series Stainless Steel	45	2335
	5MM	300 Series Stainless Steel	54	2535
	6MM	300 Series Stainless Steel	60	2891

PERFORMANCE DATA - TYPE TPXS™ PILOT PINS

METRIC	Pin Dia. Code	Test Sheet Material	Sheet Hardness HRB	Installation (kN)	Pushout (kN)
	3MM	Aluminum	22	12	0.56
		Steel	65	22	0.98

PEM® Dimple
(Registered Trademark)

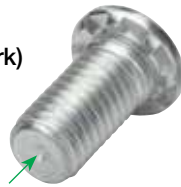

Regulatory compliance information is available in Technical Support section of our website. © 2013 PennEngineering.

Specifications subject to change without notice. See our website for the most current version of this bulletin.

PennEngineering®



North America: Danboro, PA USA • E-mail: info@pemnet.com • Tel: +1-215-766-8853 • Fax: +1-215-766-0143 • 800-237-4736 (USA Only)
Europe: Galway, Ireland • E-mail: europe@pemnet.com • Tel: +353-91-751714 • Fax: +353-91-753541
Asia/Pacific: Singapore • E-mail: singapore@pemnet.com • Tel: +65-6-745-0660 • Fax: +65-6-745-2400
 Shanghai, China • E-mail: china@pemnet.com • Tel: +86-21-5868-3688 • Fax: +86-21-5868-3988

Visit our PEMNET™ Resource Center at www.pemnet.com

Technical support e-mail: techsupport@pemnet.com