

## 3.3V, PCI Express® 3.0 2-Lane, 2:1 Mux/DeMux Switch, with Single Enable

### Features

- 4 Differential Channel, 2:1 Mux/DeMux
- PCI Express® 3.0 Performance, 8.0Gbps
- Bi-directional Operation
- Low Bit-to-Bit Skew, 10ps max
- Low channel-to-channel skew, 20ps max
- Low Crosstalk: -35dB@4 GHz
- High Off Isolation: -22dB@4 GHz (8.0Gbps)
- Low insertion loss: -1.3dB@4 GHz (8.0Gbps)
- Return loss: -21dB@4 GHz
- Support for DP1.2 - HBR2, HBR, RBR
- Supply Voltage 3.3V
- Packaging (Pb-free & Green):
  - 42-contact, TQFN (ZH42)

### Description

Pericom Semiconductor's PI3PCIE3412 is an 8 to 4 differential channel multiplexer/demultiplexer switch. This solution can switch 2 full PCI Express® 3.0, lanes to one of two locations. Using a unique design technique, Pericom has been able to minimize the impedance of the switch such that the attenuation observed through the switch is minimal. The unique design technique also offers a layout targeted for PCI Express signals, which minimizes the channel to channel skew as well as channel to channel crosstalk as required by the PCI Express specification. PI3PCIE3412 can also be used for application up to 12Gbps

### Application

Routing of PCI Express 3.0, DP1.2, USB 3.0, SAS2, SATA3 signals with low signal attenuation.

### Block Diagram

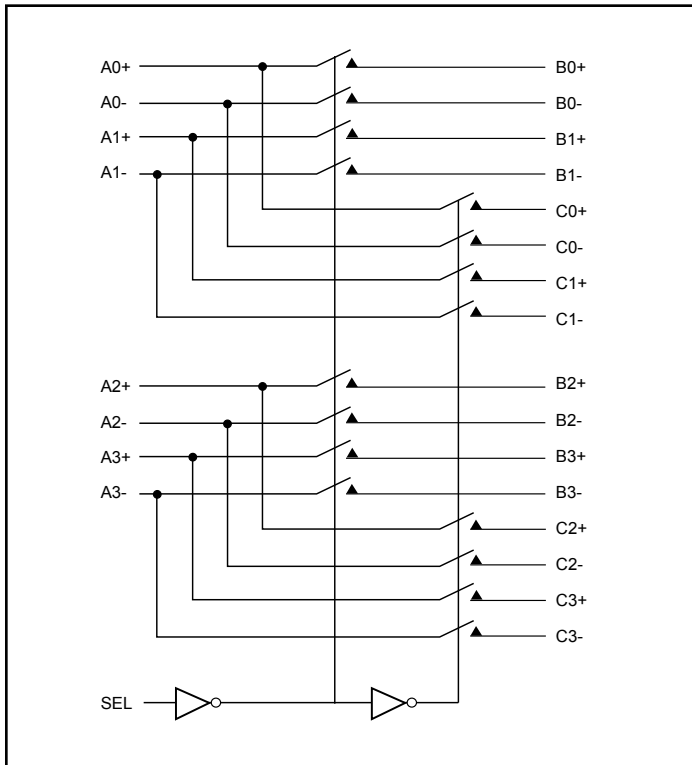

### Truth Table

Function	SEL
A <sub>N</sub> to B <sub>N</sub>	L
A <sub>N</sub> to C <sub>N</sub>	H

### Pin Description (Top-side view)

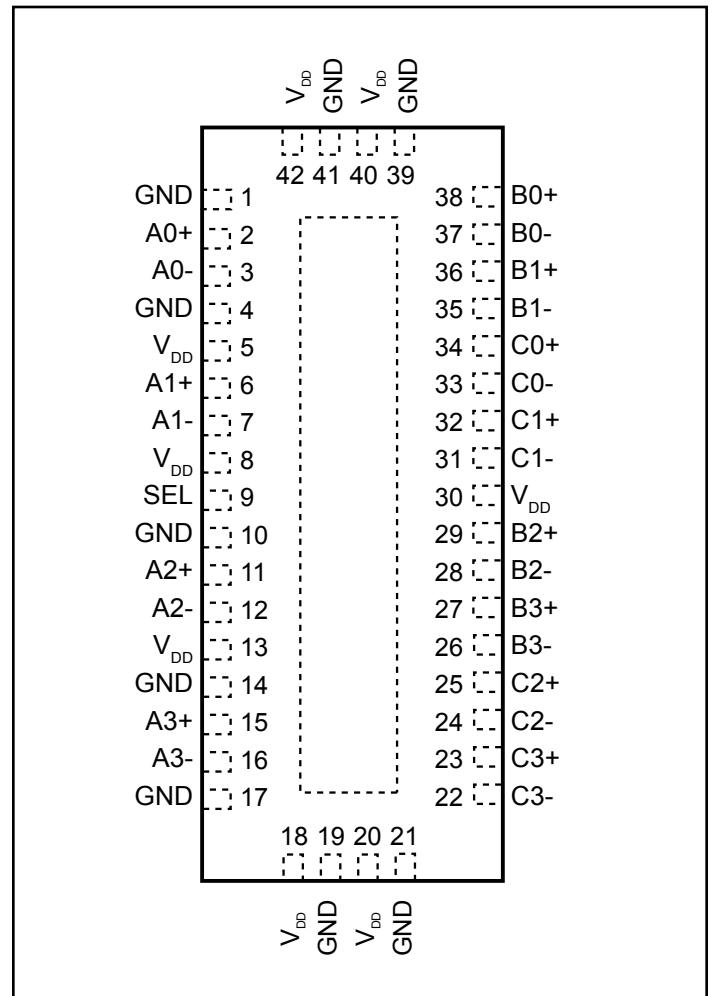

### Pin Description

Pin #	Pin Name	I/O	Description
2 3	A0+ A0-	I/O	Signal I/O, Channel 0, Port A
6 7	A1+ A1-	I/O	Signal I/O, Channel 1, Port A
11 12	A2+ A2-	I/O	Signal I/O, Channel 2, Port A
15 16	A3+ A3-	I/O	Signal I/O, Channel 3, Port A
38 37	B0+ B0-	I/O	Signal I/O, Channel 0, Port B
36 35	B1+ B1-	I/O	Signal I/O, Channel 1, Port B
29 28	B2+ B2-	I/O	Signal I/O, Channel 2, Port B
27 26	B3+ B3-	I/O	Signal I/O, Channel 3, Port B
34 33	C0+ C0-	I/O	Signal I/O, Channel 0, Port C
32 31	C1+ C1-	I/O	Signal I/O, Channel 1, Port C
25 24	C2+ C2-	I/O	Signal I/O, Channel 2, Port C
23 22	C3+ C3-	I/O	Signal I/O, Channel 3, Port C
9	SEL	I	Operation mode Select (when SEL=0: A→B, when SEL=1: A→C)
5, 8, 13,18, 20, 30, 40, 42	V <sub>DD</sub>	Pwr	3.3V ±10% Positive Supply Voltage
1, 4, 10,14, 17, 19, 21, 39, 41, Center Pad	GND	Pwr	Power ground



**Maximum Ratings**

(Above which useful life may be impaired. For user guidelines, not tested.)

Storage Temperature .....	-65°C to +150°C
Supply Voltage to Ground Potential .....	-0.5V to +4.6V
Channel DC Input Voltage .....	-0.5V to 1.5V
DC Output Current .....	120mA
Power Dissipation .....	0.5W
SEL DC Input Voltage .....	-0.5V to 4.6V

**Note:** Stresses greater than those listed under MAXIMUM RATINGS may cause permanent damage to the device. This is a stress rating only and functional operation of the device at these or any other conditions above those indicated in the operational sections of this specification is not implied. Exposure to absolute maximum rating conditions for extended periods may affect reliability.

**Electrical Characteristics**

**Recommended Operating Conditions**

Symbol	Parameter	Conditions	Min	Typ	Max	Units
V <sub>DD</sub>	3.3V Power Supply		3.0	3.3	3.6	V
I <sub>DD</sub>	Total current from V <sub>DD</sub> 3.3V supply	SEL = 0V or V <sub>DD</sub>		0.15	1	mA
T <sub>CASE</sub>	Case temperature range for operation within spec.		-40		85	Celsius

**DC Electrical Characteristics for Switching over Operating Range**

Parameters	Description	Test Conditions <sup>(1)</sup>	Min	Typ <sup>(1)</sup>	Max	Units
V <sub>IH</sub> - SEL	Input HIGH Voltage, SEL Input		2		3.6	V
V <sub>IL</sub> - SEL	Input LOW Voltage, SEL Input		0		0.8	
V <sub>IK</sub>	Clamp Diode Voltage	V <sub>DD</sub> = Max., I <sub>IN</sub> = -18mA		-0.7	-1.2	
I <sub>IH</sub>	Input HIGH Current, SEL	V <sub>DD</sub> = Max., V <sub>IN</sub> = V <sub>DD</sub>			±5	µA
I <sub>IL</sub>	Input LOW Current, SEL	V <sub>DD</sub> = Max., V <sub>IN</sub> = 0V			±5	
I <sub>IN</sub> - SEL	Input Leakage Current, SEL Input	V <sub>IN</sub> = V <sub>IH</sub> - SEL Max or V <sub>IL</sub> - SEL Min	-10		+10	µA
I <sub>IH</sub>	Input HIGH Current, A <sub>X</sub> , B <sub>X</sub> , C <sub>X</sub>	V <sub>DD</sub> = Max., V <sub>IN</sub> = 1.5V	-10		+10	µA
I <sub>IL</sub>	Input LOW Current, A <sub>X</sub> , B <sub>X</sub> , C <sub>X</sub>	V <sub>DD</sub> = Max., V <sub>IN</sub> = 0V	-10		+10	
I <sub>IOZH</sub>	HighZ HIGH Current, B <sub>X</sub> , C <sub>X</sub>	V <sub>DD</sub> = Max., V <sub>IN</sub> = 1.5V	-10		+10	µA
I <sub>IOZL</sub>	HighZ LOW Current, B <sub>X</sub> , C <sub>X</sub>	V <sub>DD</sub> = Max., V <sub>IN</sub> = 0V	-10		+10	µA

**Note:**

1. Typical values are at V<sub>DD</sub> = 3.3V, T<sub>A</sub> = 25°C ambient and maximum loading.

**Switching Characteristics**

Parameters	Description	Test Conditions	Min.	Typ.	Max.	Units
t <sub>PZH</sub> , t <sub>PZL</sub>	Line Enable Time - SEL to A <sub>N</sub> , B <sub>N</sub> , C <sub>N</sub>		2	20	25	ns
t <sub>PHZ</sub> , t <sub>PLZ</sub>	Line Disable Time - SEL to A <sub>N</sub> , B <sub>N</sub> , C <sub>N</sub>		2	5	25	
t <sub>b-b</sub>	Bit-to-bit skew within the same differential pair			5	10	ps
t <sub>ch-ch</sub>	Channel-to-channel skew				20	ps



**Dynamic Electrical Characteristics**

Parameter	Description	Test Conditions	Min.	Typ. <sup>(1)</sup>	Max.	Units
DDIL	Differential Insertion Loss ( $V_{IN} = -10\text{dBm}$ , DC = 0V)	f= 50MHz - 1.25GHz f=1.25GHz - 2.5GHz f=2.5GHz - 4GHz f=5GHz		-0.8 -1.0 -1.3 -1.8	-1 -1.2 -1.6 -2.2	dB
DDIL <sub>OFF</sub>	Differential Off Isolation	f= 50MHz - 1.25GHz f=1.25GHz - 2.5GHz f=2.5GHz - 4GHz f=5GHz	-26.3 -21.4 -17.6 -16	-32.9 -26.7 -22 -20		dB
DDRL	Differential Return Loss	f= 50MHz - 1.25GHz f=1.25GHz - 2.5GHz f=2.5GHz - 4GHz f=5GHz	-20 -18.4 -16.8 -9.6	-25 -23 -21 -12		dB
DDNEXT	Near End Crosstalk	f= 50MHz - 1.25GHz f=1.25GHz - 2.5GHz f=2.5GHz - 4GHz f=5GHz	-34.1 -30.5 -28.1 -27.2	-42.6 -38.1 -35.1 -34		dB
V <sub>IF</sub>	Max Signal Frequency Range	Insertion loss 1.5dB, $V_{IN}=0.623\text{Vpp}$ , DC=0V		4.0		GHz
		Insertion loss 1.5dB, $V_{IN}=0.623\text{Vpp}$ , DC=0.9V		4.0		
		Insertion loss 3dB, $V_{IN}=0.623\text{Vpp}$ , DC=0V		8.0		
		Insertion loss 3dB, $V_{IN}=0.623\text{Vpp}$ , DC=0.9V		8.0		
BW	-3dB Bandwidth			8.2		GHz

**Notes:**

1. Guaranteed by design. Typical values are at  $V_{DD} = 3.3\text{V}$ ,  $T_A = 25^\circ\text{C}$  ambient and maximum loading.

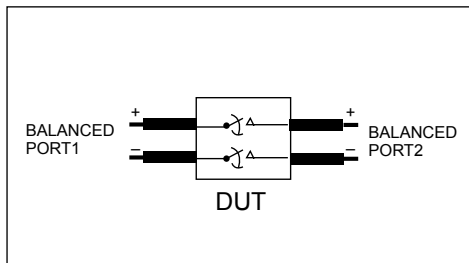

**Diff. Insertion Loss and Return Test Circuit**

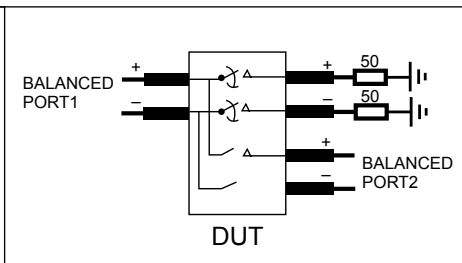

**Diff. Off Isolation Test Circuit**

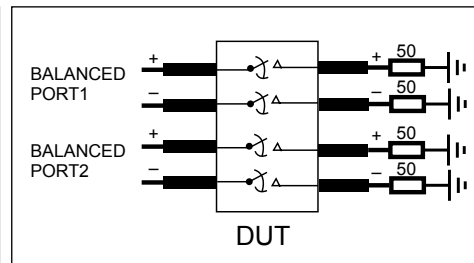

**Diff. Near End Xtalk Test Circuit**

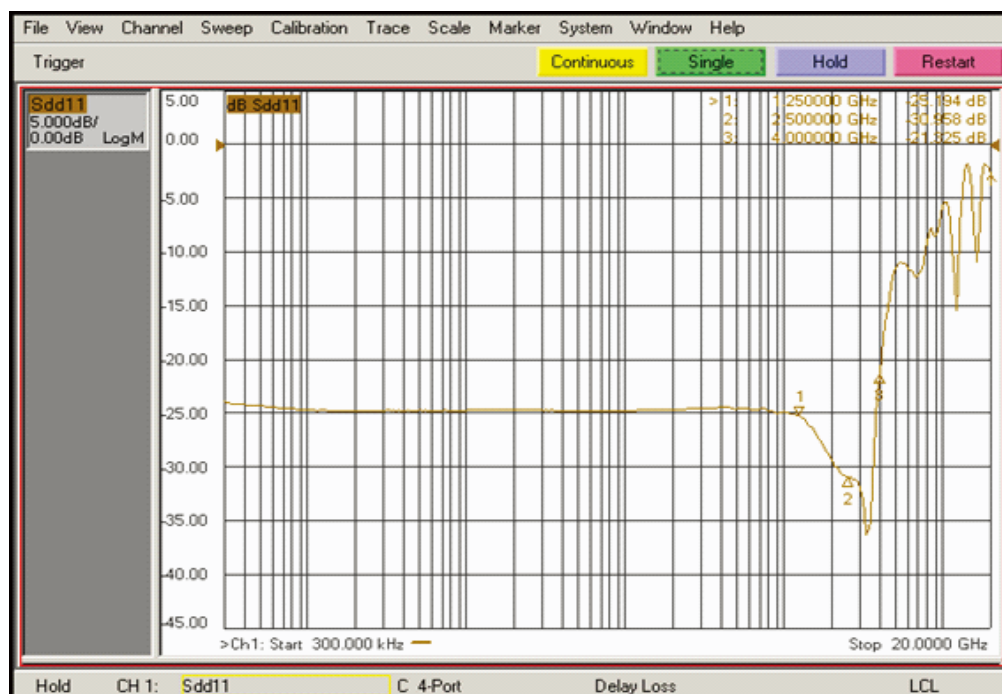

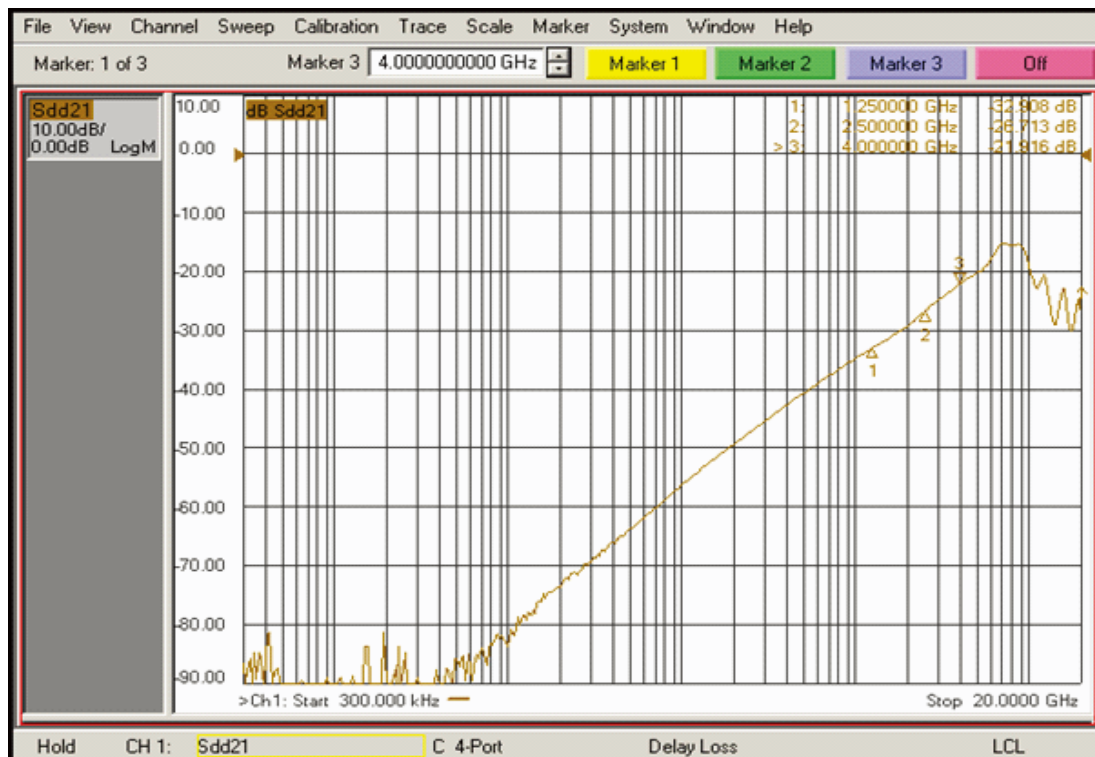
**Differential Insertion Loss**

**Differential Return Loss**

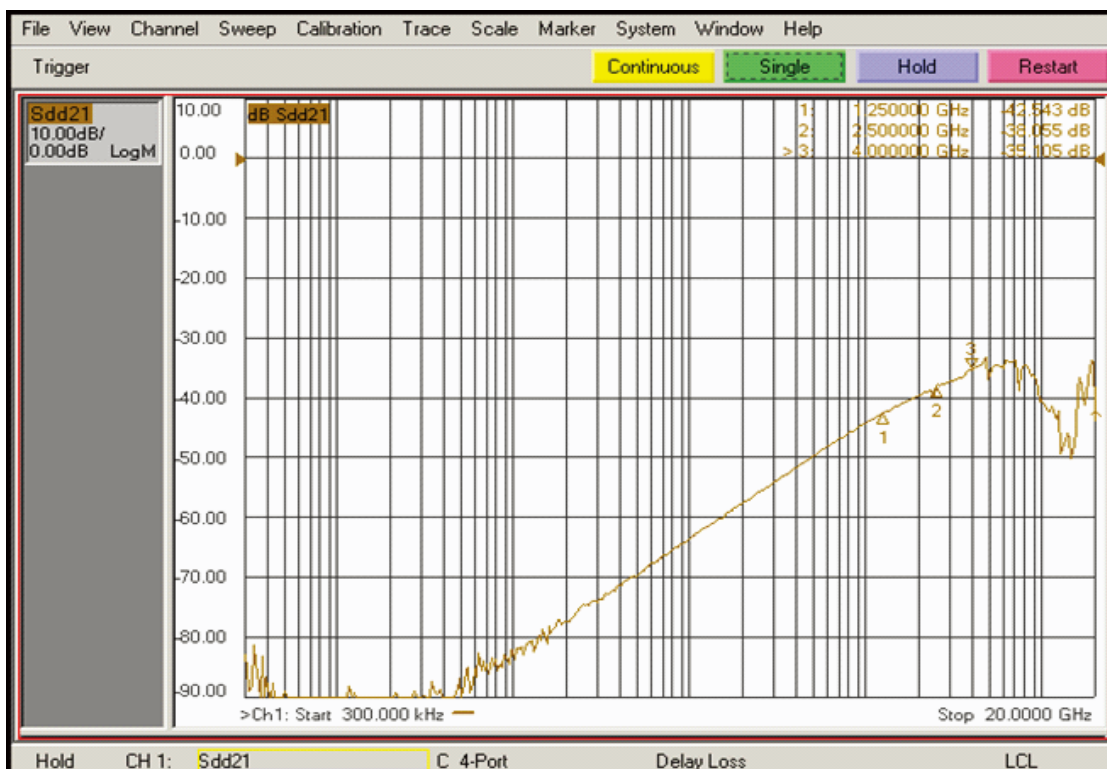

**Differential Off Isolation**

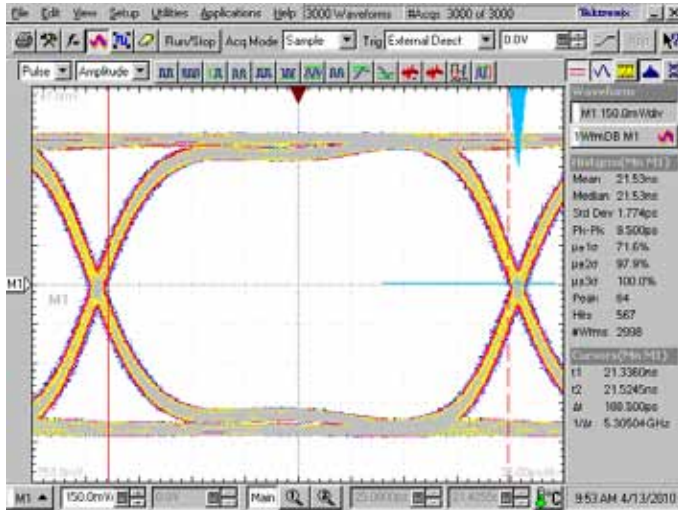

**Differential Crosstalk**



5.0 Gbps RX signal eye without PI3PCIE3412

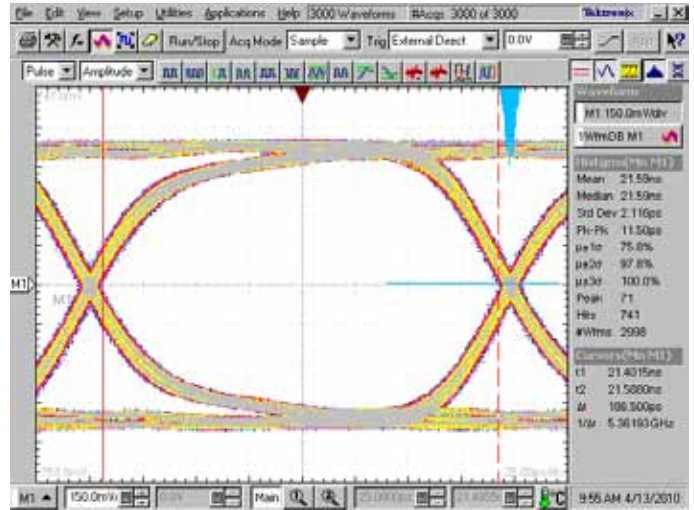

5.0 Gbps RX signal eye with PI3PCIE3412

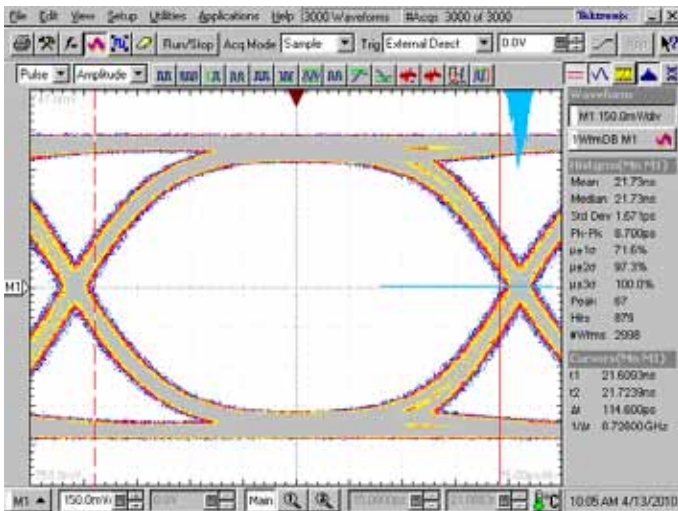

8.0 Gbps RX signal eye without PI3PCIE3412

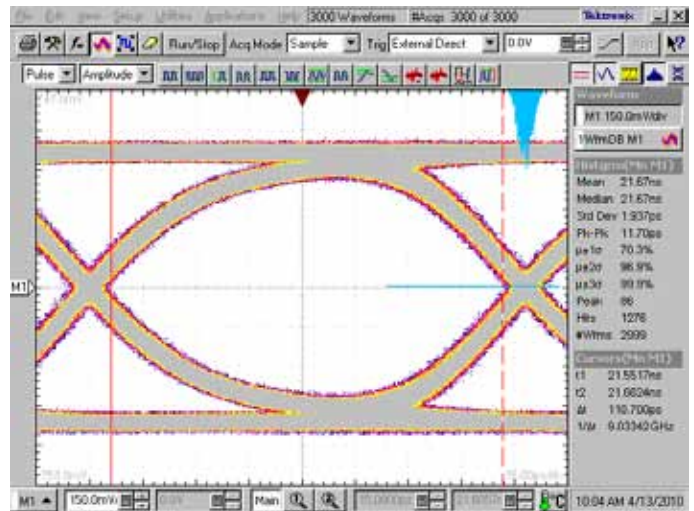

8.0 Gbps RX signal eye with PI3PCIE3412

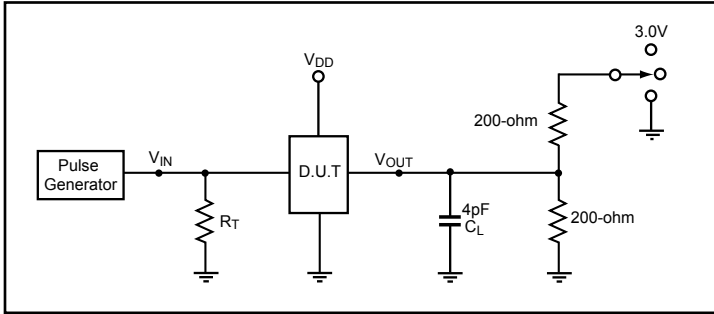
**Test Circuit for Electrical Characteristics<sup>(1-5)</sup>**

**Switch Positions**

Test	Switch
$t_{PLZ}$ , $t_{PZL}$	3.0V
$t_{PHZ}$ , $t_{PZH}$	GND
Prop Delay	Open

**Notes:**

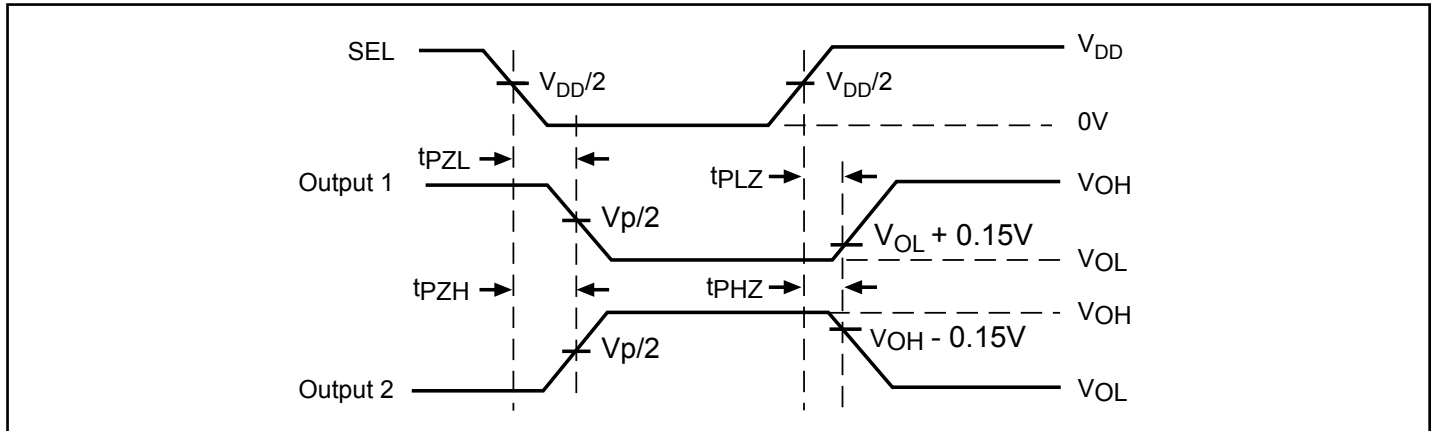
- $C_L$  = Load capacitance: includes jig and probe capacitance.
- $R_T$  = Termination resistance: should be equal to  $Z_{OUT}$  of the Pulse Generator
- Output 1 is for an output with internal conditions such that the output is low except when disabled by the output control.  
Output 2 is for an output with internal conditions such that the output is high except when disabled by the output control.
- All input impulses are supplied by generators having the following characteristics:  $PRR \leq \text{MHz}$ ,  $Z_O = 50\Omega$ ,  $t_R \leq 2.5\text{ns}$ ,  $t_F \leq 2.5\text{ns}$ .
- The outputs are measured one at a time with one transition per measurement.

**Switching Waveforms**

**Voltage Waveforms Enable and Disable Times**

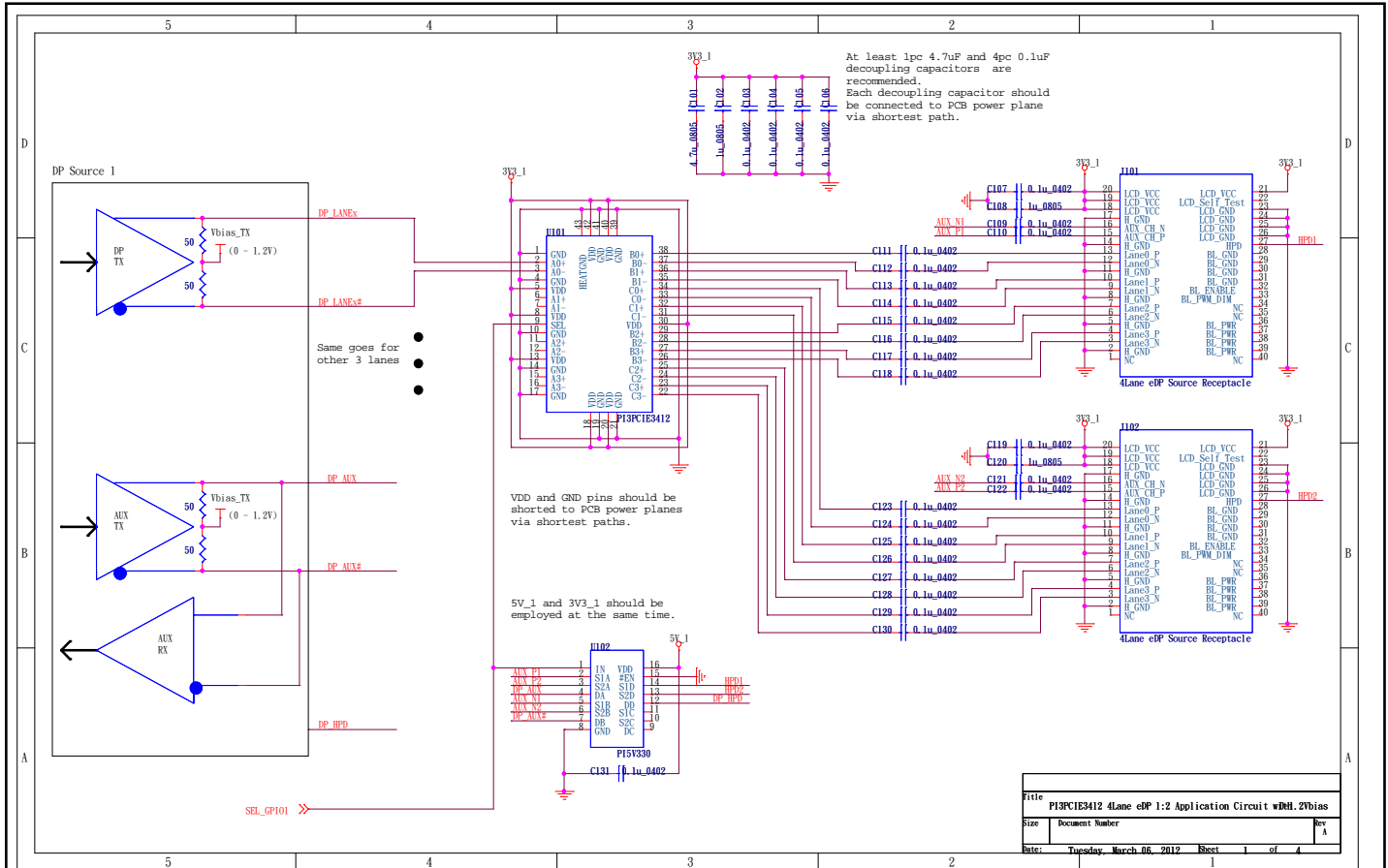
### DP1.2 Application

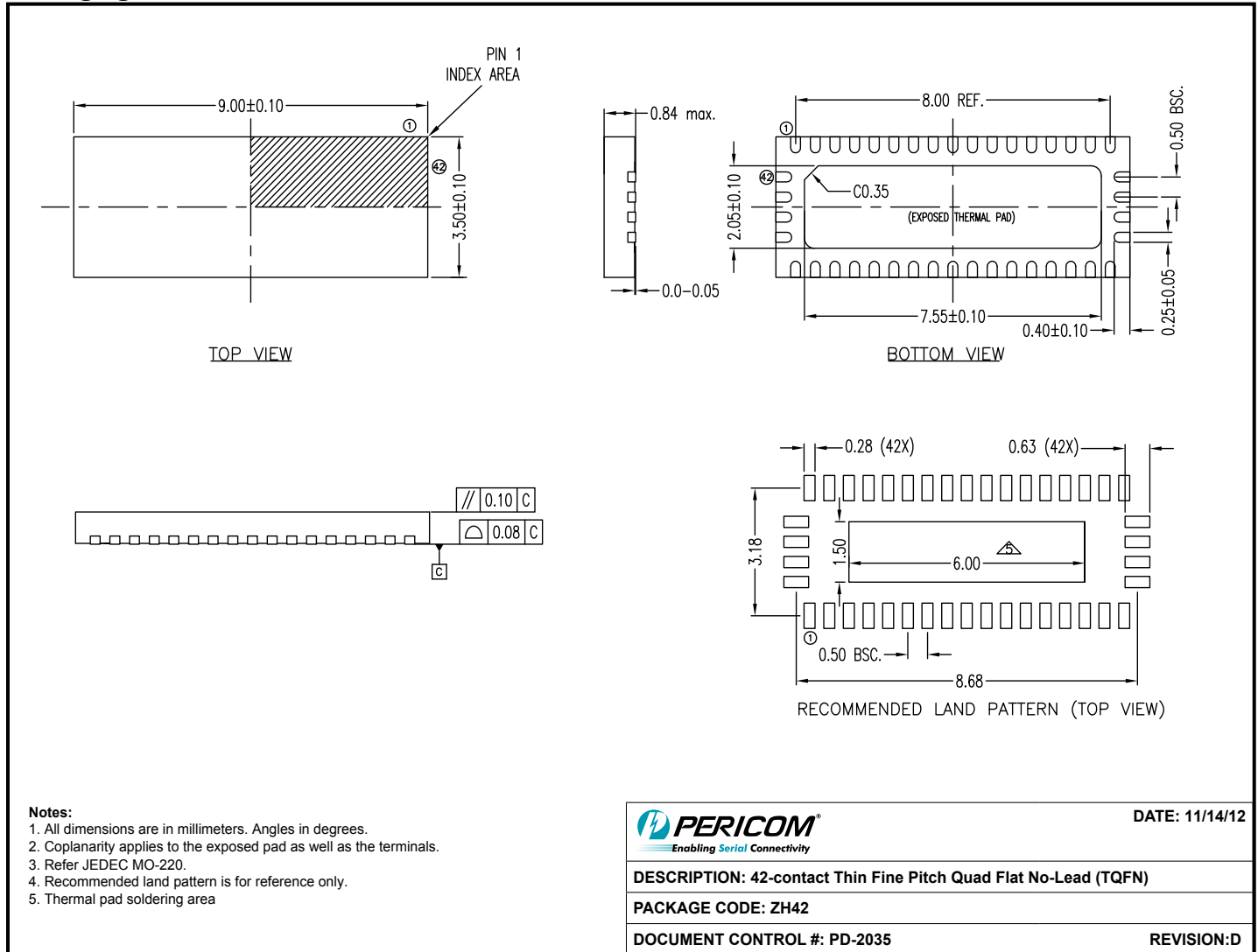

### Packaging Information



**Note:**

• For latest package info, please check: <http://www.pericom.com/products/packaging/mechanicals.php>

### Ordering Information

Ordering Code	Package Code	Package Description
PI3PCIE3412ZHE	ZH	Pb-free & Green, 42-contact TQFN

**Notes:**

- Thermal characteristics can be found on the company web site at [www.pericom.com/packaging/](http://www.pericom.com/packaging/)
- "E" denotes Pb-free and Green
- Adding an "X" at the end of the ordering code denotes tape and reel packaging