

- Integrated PXI Module With Built In High Performance Screened Analog Bus
- 2-Slot Configurations to 88x8 (1-Pole),  
4-Slot Configurations to 176x8 (1-Pole)  
8-Slot Configurations to 352x8 (1-Pole)
- Switch up to 100 VDC/70 VAC, 2 A, 60 W
- Automatic Analog Bus Isolation Switching  
Maximizes Bandwidth and Matrix Reliability
- VISA, IVI & Kernel Drivers Supplied for Windows
- Supported by PXI or LXI Chassis
- Supported by *eBIRST*™
- 3 Year Warranty



## BRIC™ 2nd Generation PXI 2Amp Switch Matrix

The 40-567 BRIC is a range of high density matrix modules able to switch up to 2 Amps or 100 VDC/70 VAC. The 40-567 BRIC modules are available in 2, 4 or 8-slot sizes to suit most high performance PXI matrix requirements, constructed using high quality electro-mechanical relays for high switching confidence.

Typical applications include signal routing for functional ATE systems. With its high level of switching density, 40-567 matrix modules allow a complete functional ATE system to be housed in a single 3U PXI chassis, BRIC modules allow the use of a much lower cost 8-slot PXI chassis.

## High Reliability and Easy of Use

The 40-567 PXI BRIC is designed to minimise the cost and complexity of cable assemblies to the device under test and instrumentation. Analog busing is housed within the module using a high performance screened analog backplane. Pickering can construct custom cable assemblies for all of our PXI modules, please contact sales office for further assistance.

## Supported by *eBIRST*

*eBIRST* switching system test tools simplify switching system fault-finding by quickly testing the system and graphically identifying the faulty relay.

For more information go to:  
[pickeringtest.com/ebirst](http://pickeringtest.com/ebirst)

**The 2 Amp Matrix BRIC** is a higher power/voltage version of Pickering's established range of PXI Matrix BRIC modules. It features higher voltage, current and power handling capability than the ultra high density reed relay based BRICs. It is not as suited to switching low level signals, where Ruthenium Reed Relays are a better choice and have a very long lifetime of up to 1000 million operations. For superior low level switching please refer to our 40-560/561/562 range.

Pickering's Range of 2A BRIC Matrix Modules				
Model No.	Poles	Y-Bus Size	Min. Matrix Size	Max. Matrix Size
40-568	1	4	75x4	600x4
40-596	1	6	58x6	464x6
40-567	1	8	44x8	352x8
40-597	1	12	32x12	256x12
40-598	1	16	24x16	192x16
40-566A	2	4	55x4	385x4
40-565A	2	8	24x8	192x8

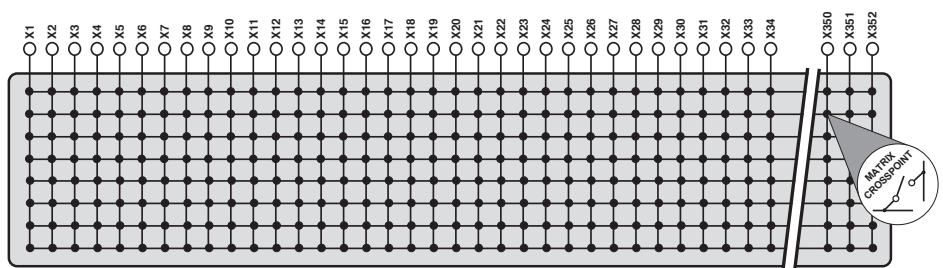

**40-567-108 352x8 Matrix Switching Diagram (Fully Populated BRIC8)**  
The 40-567 supports 8 concurrent switch paths for X to X (see application diagram overleaf)

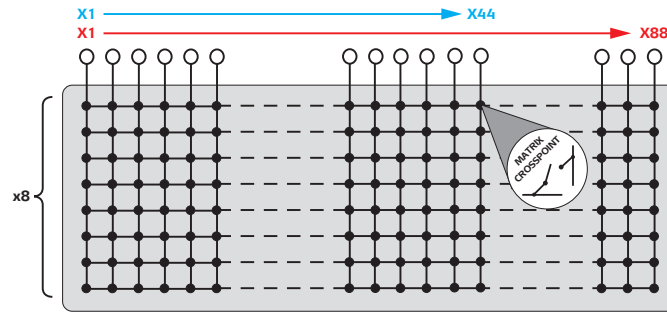

The 40-567 in BRIC2 Format is Available With Matrix Configurations of 44x8 and 88x8

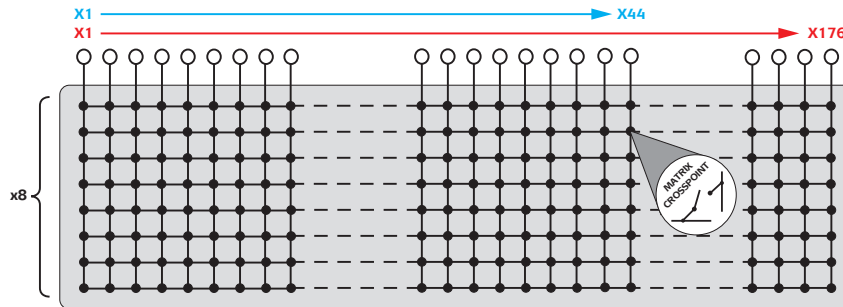

The 40-567 in BRIC4 Format is Available With Matrix Configurations Between 44x8 and 176x8

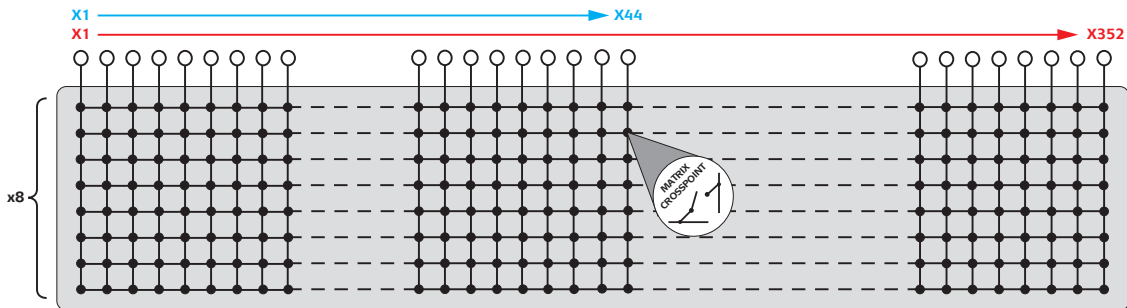

The 40-567 in BRIC8 Format is Available With Matrix Configurations Between 44x8 and 352x8

## Example Application of the 40-567 1-Pole 2A BRIC Matrix

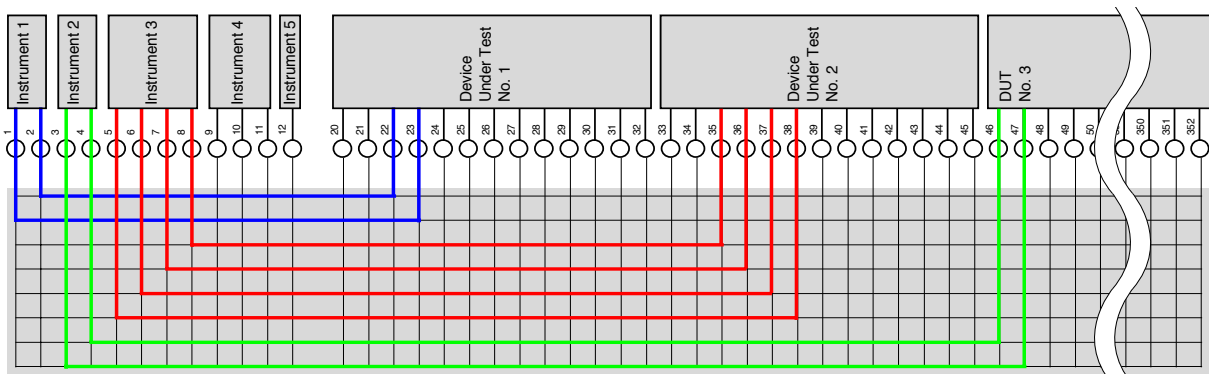

Schematic diagram showing a 352x8 BRIC Matrix being used to parallel test multiple DUTs. The BRIC Matrix allows tremendous test system flexibility.

## Relay Type

The 40-567 BRIC modules are fitted with electro-mechanical relays (Palladium-Ruthenium, Gold Covered Bifurcated).

## Switching Specification

Relay Type:	2 Amp Electro-mechanical
Contact Type:	Palladium-Ruthenium, Gold Covered Bifurcated
Max Switch Voltage:	100 VDC/70 VAC*
Max Power:	62.5 VA, 60 W
Max Switch Current:	2 A
Max Continuous Carry Current:	2 A
Max Pulsed Carry Current Example (for a single switch path):	6 A for 100 ms (up to 10% duty cycle)
Initial On Path Resistance:	<1 Ω
Off Path Resistance:	>10 <sup>9</sup> Ω
Thermal Offset:	10 μV (X to X connection)
Max Number of Simultaneously Closed Crosspoints:	BRIC2 & BRIC4: 65 BRIC8: 130
Switch Operate Time:	6.5ms
Expected Life (operations)	
Very low power signal load:	>1x10 <sup>8</sup>
Low power load (2 W):	>1.5x10 <sup>7</sup> (0.1 A, 20 VDC)
Medium power load (30 W):	>5x10 <sup>6</sup> (1 A, 30 VDC)
Full power load (60 W):	>1x10 <sup>5</sup> (2 A, 30 VDC)

\* For full voltage rating, signal sources to be switched must be fully isolated from mains supply and safety earth.

## Typical Bandwidth and Crosstalk

Bandwidth (-3 dB):	>5MHz
Crosstalk (typical):	10 kHz: -65 dB
	100 kHz: -45 dB
	1 MHz: -30 dB
	10 MHz: -15 dB
Isolation:	10 kHz: 65 dB
	100 kHz: 50 dB
	1 MHz: 30 dB
	10 MHz: 10 dB

## Matrix Functionality

Permits any X to X with multiple connections and 8 concurrent Y paths. Direct Y connections are not provided at the user connector but can be accessed by reassignment of 8 off X connections to provide Y connections. The driver prevents the connection of Y axis connections together (e.g. Y1 to Y4).

## Power Requirements - BRIC2 & BRIC4

+3.3V	+5V	+12V	-12V
50mA	1.5A	35mA	0

## Power Requirements - BRIC8

+3.3 V	+5 V	+12 V	-12 V
115 mA	2.2 A	35 mA	0

## Width and Dimensions

Two, four or eight slot 3U PXI module (CompactPCI). 3D models for these modules in a variety of popular file formats are available on request.

## Module Weight

	Empty BRIC	Fully Loaded BRIC
BRIC2	0.6 Kg	1.3 Kg
BRIC4	0.9 Kg	2.2 Kg
BRIC8	1.6 Kg	4.2 Kg
BRIC daughter card	325 g	

## Connectors

PXI bus via 32-bit P1/J1 backplane connector. Signals via multiple front panel 50-pin male D-type connectors (Up to 2 per 2-slot module, up to 4 per 4-slot module or up to 8 per 8-slot module), for pin outs please refer to the operating manual.

## Special Versions

BRIC modules can be built in special versions, for example where an exact matrix size is required then partly populated daughtercards may be ordered.

## Upgrading With Daughtercards

BRIC modules can be upgraded to larger matrix sizes using daughter-cards, please consult your local sales office for further information.

## Operating/Storage Conditions

### Operating Conditions

Operating Temperature: 0 °C to +55 °C  
Humidity: Up to 90% non-condensing  
Altitude: 5000 m

### Storage and Transport Conditions

Storage Temperature: -20 °C to +75 °C  
Humidity: Up to 90% non-condensing  
Altitude: 15000 m

## PXI & CompactPCI Compliance

The module is compliant with the PXI Specification 2.2. Local Bus, Trigger Bus and Star Trigger are not implemented.

Uses a 33 MHz 32-bit backplane interface.

## Safety & CE Compliance

All modules are fully CE compliant and meet applicable EU directives: Low-voltage safety EN61010-1:2010, EMC Immunity EN61326-1:2013, Emissions EN55011:2009+A1:2010.

## Product Order Codes

BRIC2 - 2-Slot High Density Matrix	
2 Amp 1-Pole 44x8 Matrix	40-567-201
2 Amp 1-Pole 88x8 Matrix	40-567-202
BRIC4 - 4-Slot High Density Matrix	
2 Amp 1-Pole 44x8 Matrix	40-567-001
2 Amp 1-Pole 88x8 Matrix	40-567-002
2 Amp 1-Pole 132x8 Matrix	40-567-003
2 Amp 1-Pole 176x8 Matrix	40-567-004
BRIC8 - 8-Slot High Density Matrix	
2 Amp 1-Pole 44x8 Matrix	40-567-101
2 Amp 1-Pole 88x8 Matrix	40-567-102
2 Amp 1-Pole 132x8 Matrix	40-567-103
2 Amp 1-Pole 176x8 Matrix	40-567-104
2 Amp 1-Pole 220x8 Matrix	40-567-105
2 Amp 1-Pole 264x8 Matrix	40-567-106
2 Amp 1-Pole 308x8 Matrix	40-567-107
2 Amp 1-Pole 352x8 Matrix	40-567-108

For the expansion of an existing BRIC matrix or replacement of faulty BRIC daughter cards please contact your local sales office.

## Product Customization

Pickering PXI modules are designed and manufactured on our own flexible manufacturing lines, giving complete product control and enabling simple customization to meet very specific requirements.

Customization can include:

- Alternative relay types
- Mixture of relay types
- Alternative number of relays
- Different performance specifications

All customized products are given a unique part number, fully documented and may be ordered at any time in the future.

Please contact your local sales office to discuss.

## Support Products

### eBIRST Switching System Test Tool

This product is supported by the *eBIRST* test tools which simplify the identification of failed relays, the required *eBIRST* tools are below. This product requires master slave testing and two sets of tools are required together with the master slave cable

**93-970-301**. For more information go to:

[pickeringtest.com/ebirst](http://pickeringtest.com/ebirst)

Product	Test Tool	Adaptor
40-567	93-005-001	Not Required

### Spare Relay Kits

Kits of replacement relays are available for the majority of Pickering's PXI switching products, simplifying servicing and reducing down-time.

Product	Relay Kit
40-567	91-100-001

For further assistance, please contact your local Pickering sales office.

### Mating Connectors & Cabling

For connection accessories for the 40-567 modules please refer to the [90-005D](#) 50-pin D-type Connector Accessories data sheet where a complete list and documentation can be found for accessories, or refer to the website.

## Chassis Compatibility

This PXI module must be used in a suitable chassis. It is compatible with the following chassis types:

- All chassis conforming to the 3U PXI and 3U Compact PCI (cPCI) specification
- Legacy and Hybrid Peripheral slots in a 3U PXI Express (PXIe) chassis
- Pickering Interfaces LXI or LXI/USB Modular Chassis

## Chassis Selection Guide

### Standard PXI or hybrid PXIe Chassis From Any Vendor:

- Mix our 1000+ PXI switching & simulation modules with any vendor's PXI instrumentation
- Embedded or remote Windows PC control
- Real-time Operating System Support
- High data bandwidths, especially with PXI Express
- Integrated module timing and synchronization



### Pickering LXI or LXI/USB Modular Chassis Only accept our PXI Switching & Simulation Modules:

- Choose from 1000+ Pickering PXI Modules
- Ethernet or USB control enables remote operation
- Low-cost control from practically any controller
- LXI provides manual control via Web browsers
- Driverless software support
- Power sequencing immunity
- Ethernet provides chassis/controller voltage isolation
- Independence from Windows operating system



## Connectivity Solutions

We provide a full range of supporting cable and connector solutions for all our switching products—20 connector families with 1200+ products. We offer everything from simple mating connectors to complex cables assemblies and terminal blocks. All assemblies are manufactured by Pickering and are guaranteed to mechanically and electrically mate to our modules. These accessories are detailed in Connector Accessories data sheets, where a complete list and documentation can be found for each accessory.



Connectors & Backshells



Multi-way Cable Assemblies

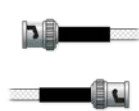

RF Cable Assemblies

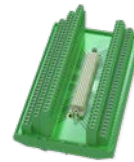

Breakouts



Connector Blocks

We also offer customized cabling and have a free online **Cable Design Tool** that can be used to create custom cable solutions for many applications.

- Fully supported on modern browsers and tablet operating systems.
- Built-in tutorials and videos allow you to get quickly up to speed.
- Store cable assemblies in the Cloud and develop over time.
- Each cable design has a downloadable PDF documentation file detailing all specifications

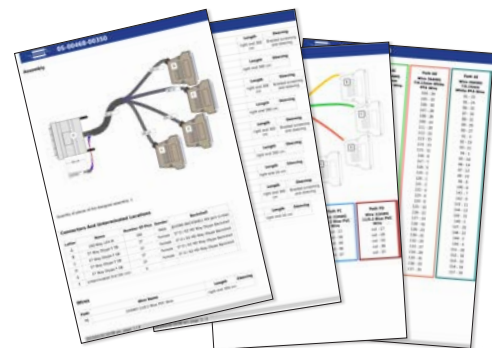

Start designing your custom cabling, go to [pickeringtest.com/cdt](http://pickeringtest.com/cdt)

## Mass Interconnect

We recommend the use of a mass interconnect solution when an Interchangeable Test Adapter (ITA) is required for PXI/LXI based test systems. Our modules are fully supported by Virginia Panel and MacPanel.

## Pickering Reed Relays

We are the only switch provider with in-house reed relay manufacturing capability via our Relay Division. These instrument grade reed relays feature **SoftCenter™** technology, ensuring long service life and repeatable contact performance.

To learn more go to [pickeringrelay.com](http://pickeringrelay.com)

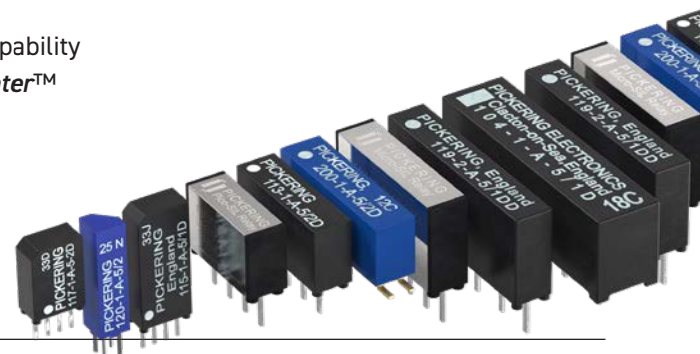

## Programming

Pickering provide kernel, IVI and VISA (NI & Keysight) drivers which are compatible with all Microsoft supported versions of Windows and popular older versions.

For more information go to [pickeringtest.com/os](http://pickeringtest.com/os)

The VISA driver support is provided for LabVIEW Real Time Operating Systems (Pharlap and Linux-RT). For other RTOS support contact Pickering. These drivers may be used with a variety of programming environments and applications including:

- **Pickering Interfaces Switch Path Manager**
- **National Instruments** products (LabVIEW, LabWindows/CVI, Switch Executive, MAX, TestStand, VeriStand, etc.)
- **Microsoft Visual Studio** products (Visual Basic, Visual C++)
- **Programming Languages** C, C++, C#, Python
- **Keysight VEE** and OpenTAP
- **Mathworks MATLAB, Simulink**
- **Marvin ATEasy**
- **MTQ Testsolutions Tecap Test & Measurement Suite**

Drivers for popular Linux distributions are available, other environments are also supported, please contact Pickering with specific enquiries. We provide Soft Front Panels (SFPs) for our products for familiarity and manual control, as well as comprehensive documentation and example programs to help you develop test routines with ease.

To learn more about software drivers and development environments go to [pickeringtest.com/software](http://pickeringtest.com/software)

## Signal Routing Software

Our signal routing software, Switch Path Manager, automatically selects and energizes switch paths through Pickering switching systems. Signal routing is performed by simply defining test system endpoints to be connected together, greatly accelerating Test System software development.

To learn more go to [pickeringtest.com/spm](http://pickeringtest.com/spm)

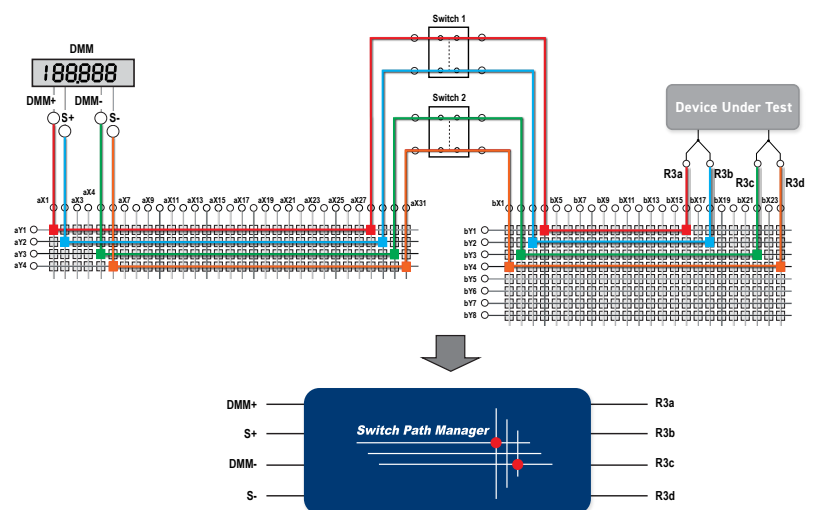

## Diagnostic Relay Test Tools

eBIRST Switching System Test Tools are designed specifically for our PXI, PCI or LXI products, these tools simplify switching system fault-finding by quickly testing the system and graphically identifying the faulty relay.

To learn more go to [pickeringtest.com/ebirst](http://pickeringtest.com/ebirst)



## Three Year Warranty & Guaranteed Long-Term Support

All standard products manufactured by Pickering Interfaces are warranted against defective materials and workmanship for three years from the date of delivery to the original purchaser. Extended warranty and service agreements are available with various levels for your requirements. Although we offer a 3-year warranty as standard, we also include guaranteed long-term support—with a history of supporting our products for typically 15-20 years.

To learn more go to [pickeringtest.com/support](http://pickeringtest.com/support)

## Available Product Resources

We have a library of resources including success stories, product and support videos, articles and white papers as well as application-specific brochures to assist you. We have also published reference books on switching technology and the PXI and LXI standards.

To view, download or request any of our product resources go to [pickeringtest.com/resources](http://pickeringtest.com/resources)

