

- Standard Voltage to 250V AC/400V DC, 5 A
- Cable Assemblies
- Cable Connectors & Connector Blocks
- Breakouts & PCB Connectors
- Guaranteed Compatibility
- High Voltage Solutions are also Available
See Data Sheet 90-005HVD



Simple Connection

Pickering connection solutions provide a simple way of connecting to a user's device under test or remote connection. The products include cable assemblies, cable connectors, connector blocks, breakouts and pcb connectors.

Cable Assemblies

Cable assemblies are offered in connector to connector, and connector to unterminated versions. There are 3 termination options for the unterminated cables - ferrules, tinned copper or simple cut end.

Connector Blocks

Connector Blocks convert the 50-pin D-type connections to an array of screw terminals. The customer can then interface to other devices using his own wiring. An alternative is a remote Breakout with screw terminals at the end of a cable assembly.

Custom Design Needs



Pickering Interfaces can manufacture custom connector accessories to suit any application. If you do not see what you need in this data sheet contact your Pickering Interfaces sales office with information on your requirements or consider using our free online Cable Design Tool.

Using our Cable Design Tool, you can graphically design your own custom cable assembly. Once completed and submitted, our engineers will generate a quote for your cable requirements. See pickeringtest.com/cdt





Examples of Pickering PXI and LXI Products
using 50-Pin D-type Connectors

Standard Voltage - Cable Assemblies





Description		End 1	End 2		Cable Length	Product Order Code and Part Number	Data Sheet Page
		Gender & Cable Exit	Gender & Cable Exit	Options			
	Cable Assy, 50-Pin D-Type, 5A	Male, 45° Away from Pin 1	Female, 45° Away from Pin 1	-	0.5 m 1 m 2 m	40-970-050-0.5m-MF 40-970-050-1m-MF 40-970-050-2m-MF	5
		Male, 45° Towards Pin 1	Female, 45° Towards Pin 1	-	0.5 m 1 m 2 m	A050DM5-050DF5-0A050 A050DM5-050DF5-0A100 A050DM5-050DF5-0A200	
		Female, 45° Away from Pin 1	Female, 45° Away from Pin 1	-	0.5 m 1 m 2 m	40-970-050-0.5m-FF 40-970-050-1m-FF 40-970-050-2m-FF	6
		Female, 45° Towards Pin 1	Female, 45° Towards Pin 1	-	0.5 m 1 m 2 m	A050DF5-050DF5-0A050 A050DF5-050DF5-0A100 A050DF5-050DF5-0A200	
	Cable Assy, 50-Pin D-Type to Underterminated, 5A	Female, 45° Away from Pin 1	NA	Ferrules	0.5 m 1 m 2 m	40-972-050-0.5m-FU 40-972-050-1m-FU 40-972-050-2m-FU	7
				Tinned End	0.5 m 1 m 2 m	A050DF4-T-0A050 A050DF4-T-0A100 A050DF4-T-0A200	
				Cut End	0.5 m 1 m 2 m	A050DF4-C-0A050 A050DF4-C-0A100 A050DF4-C-0A200	
		Female, 45° Towards Pin 1	NA	Ferrules	0.5 m 1 m 2 m	A050DF5-F-0A050 A050DF5-F-0A100 A050DF5-F-0A200	
				Tinned End	0.5 m 1 m 2 m	A050DF5-T-0A050 A050DF5-T-0A100 A050DF5-T-0A200	
				Cut End	0.5 m 1 m 2 m	A050DF5-C-0A050 A050DF5-C-0A100 A050DF5-C-0A200	

Note: Custom lengths by quotation. Max length 5 m



Specific Function Cable Assemblies

Description		End 1	End 2		Cable Length	Product Order Code and Part Number	Data Sheet Page
		Gender & Cable Exit	Gender & Cable Exit	Options			
	Cable Assy, 50-Pin D-Type 5A Twisted Pairs	Male, 45° Away from Pin 1	Female, 45° Away from Pin 1	-	0.5 m 1 m 2 m	A050DM4-050DF4-TA050 A050DM4-050DF4-TA100 A050DM4-050DF4-TA200	8
	Cable Assy, 50-Pin D-Type to Underterminated 5A Twisted Pairs	Female, 45° Away from Pin 1	NA	Cut End	0.5 m 1 m 2 m	A050DF4-C-TA050 A050DF4-C-TA100 A050DF4-C-TA200	9

Standard Voltage - Female Connector Blocks/Connectors

Description		Gender & Cable Exit	Type	Product Order Code and Part Number	Page
	Shielded Connector Block, 50-Pin D-Type, 5 A, Screw Terminal	Female, Rear	With Backshell	40-965A-050-F	11
			Without Backshell	92-965-050-F	
	Breakout with DIN Rail Mount, 50-Pin D-Type, 5 A, Screw Terminal	Female	DIN Rail Mount	40-967-050-F	12
	Cable Connector 50-Pin D-Type, 5 A, Solder Bucket	Female, 45° Options	With Backshell	40-960-050-F	13
			Without Backshell	92-960-050-F	
	PCB Connector 50-Pin D-Type, 5 A	Female	Right Angle PCB Mount	40-963-050-RF	14
			Straight PCB Mount	40-963-050-SF	15



Standard Voltage - Male Breakouts/PCB Connectors

Description		Gender & Cable Exit	Type	Product Order Code and Part Number	Page
	Breakout with DIN Rail Mount, 50-Pin D-Type, 5 A, Screw Terminal	Male	DIN Rail Mount	40-967-050-M	16
	PCB Connector 50-Pin D-Type, 5 A	Male	Right Angle PCB Mount	40-963-050-RM	17
			Straight PCB Mount	40-963-050-SM	18

Additional Accessories

Although the items below do not directly mate with Pickering Interfaces products, customers may find them useful in the development of their own connection solutions.

Standard Voltage - Cable Assemblies

Description		End 1	End 2		Cable Length	Product Order Code and Part Number	Data Sheet Page
		Gender & Cable Exit	Gender & Cable Exit	Options			
	Cable Assy, 50-Pin D-Type, 5 A	Male, 45° Away from Pin 1	Male, 45° Away from Pin 1	-	0.5 m 1 m 2 m	40-970-050-0.5m-MM 40-970-050-1m-MM 40-970-050-2m-MM	20
		Male, 45° Towards Pin 1	Male, 45° Towards Pin 1	-	0.5 m 1 m 2 m	A050DM5-050DM5-0A050 A050DM5-050DM5-0A100 A050DM5-050DM5-0A200	
	Cable Assy, 50-Pin D-Type to Underterminated, 5 A	Male, 45° Away from Pin 1	NA	Ferrules	0.5 m 1 m 2 m	40-972-050-0.5m-MU 40-972-050-1m-MU 40-972-050-2m-MU	21
				Tinned End	0.5 m 1 m 2 m	A050DM4-T-0A050 A050DM4-T-0A100 A050DM4-T-0A200	
				Cut End	0.5 m 1 m 2 m	A050DM4-C-0A050 A050DM4-C-0A100 A050DM4-C-0A200	
		Male, 45° Towards Pin 1	NA	Ferrules	0.5 m 1 m 2 m	A050DM5-F-0A050 A050DM5-F-0A100 A050DM5-F-0A200	
				Tinned End	0.5 m 1 m 2 m	A050DM5-T-0A050 A050DM5-T-0A100 A050DM5-T-0A200	
				Cut End	0.5 m 1 m 2 m	A050DM5-C-0A050 A050DM5-C-0A100 A050DM5-C-0A200	

Note: Custom lengths by quotation. Max length 5 m

Standard Voltage - Male Breakouts/Connectors

Description	Gender & Cable Exit	Type	Product Order Code and Part Number	Page
	Male, 45° Options	With Backshell	40-960-050-M	22
		Without Backshell	92-960-050-M	

Cable Management

Rack Mount Cable Management Kit..... 23

Custom Termination

Customization Possibilities..... 24

- High Specification, Highly Flexible Cable
- Fully Screened Cable Construction with Strain Relief
- 45° Cable Exit

Technical Specification

Connector Type (End A):	50-Pin D-Subminiature
Gender	Female
Securing Method	4-40 UNC screwlocks, male
Connector Type (End B):	50-Pin D-Subminiature
Gender	Male
Securing Method	4-40 UNC screwlocks, male
Maximum Current	5 A
Maximum Voltage	250 VAC/400 VDC
Insulation Resistance	1000 MΩ
Connectors:	
Contact Material	Gold plated copper alloy
Contact Resistance	<20 mΩ
Cable Exit	45° (See Order Codes)
Overall Size (Approx)	H68 x W18.5 x D55 mm
Cable Type:	Individual wires, screened & sleeved
Conductor: Material	Copper
Strands	19/0.18 (0.41mm ² , 21AWG)
Resistance	0.041Ω/m
Insulation	PFA
Outer Sleeve	Polyester
Screened Construction	Yes (Cable screen connected to backshells)
Additional Braided Sleeve	Yes
Cable O/D	12 mm
Minimum Bend Radius	25 mm
Door Closure Allowance	55 mm(see diagram)



50-Pin D-Type Cable Assembly

Product Compatibility

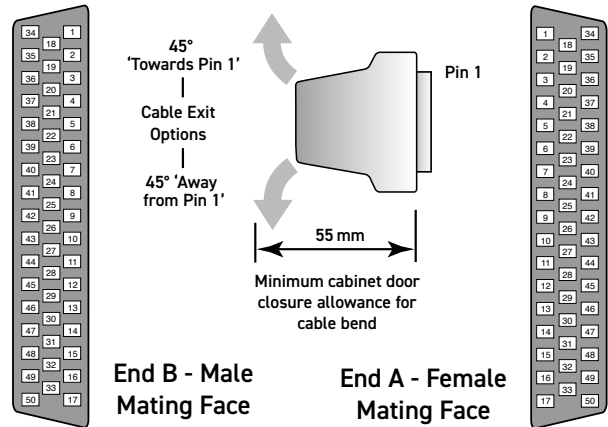
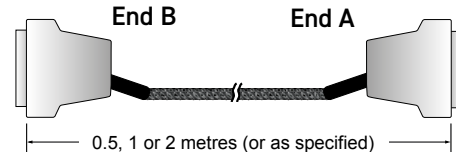
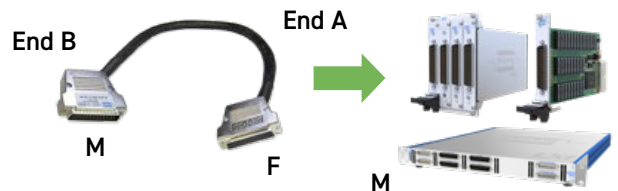

Characteristic Plots for 40-970-050-1m

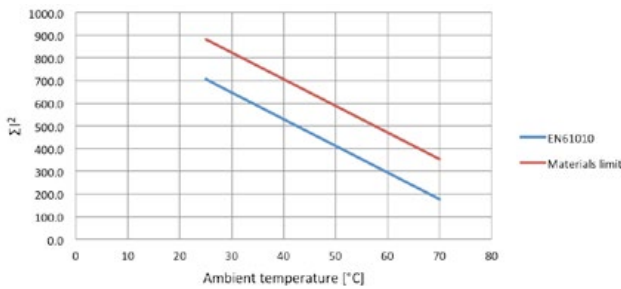

The graph shows the permitted ΣI^2 versus ambient temperature in accordance with EN61010 for user exposure to surface temperature and a higher limit imposed by the materials used where the cable is not directly user accessible.

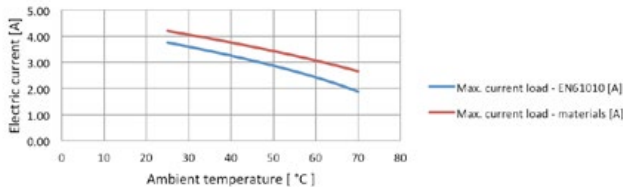

The graph shows the allowed current versus temperature assuming ALL wires carry the same current. Higher currents to the cable rating are permitted on individual wires provided the ΣI^2 is complied with.

Product Order Codes

50-Pin D-Type Cable Assy, 5 A, Male to Female,
Cable Exit 45° (Away from Pin 1),

- 0.5 m Long [40-970-050-0.5m-MF](#)
- 1.0 m Long [40-970-050-1m-MF](#)
- 2.0 m Long [40-970-050-2m-MF](#)

Cable Exit 45° (Towards Pin 1),

- 0.5 m Long [A050DM5-050DF5-0A050](#)
- 1.0 m Long [A050DM5-050DF5-0A100](#)
- 2.0 m Long [A050DM5-050DF5-0A200](#)

Note: Other cable lengths can be supplied. Max length 5m

- High Specification, Highly Flexible Cable
- Fully Screened Cable Construction with Strain Relief
- 45° Cable Exit

Technical Specification

Connector Type (End A):	50-Pin D-Subminiature
Gender	Female
Securing Method	4-40 UNC screwlocks, male
Connector Type (End B):	50-Pin D-Subminiature
Gender	Female
Securing Method	4-40 UNC screwlocks, male
Maximum Current	5 A
Maximum Voltage	250 VAC/400 VDC
Insulation Resistance	1000 MΩ
Connectors:	
Contact Material	Gold plated copper alloy
Contact Resistance	<20 mΩ
Cable Exit	45° (See Order Codes)
Overall Size (Approx)	H68 x W18.5 x D55 mm
Cable Type:	Individual wires, screened & sleeved
Conductor: Material	Copper
Strands	19/0.18 (0.41mm ² , 21AWG)
Resistance	0.041 Ω/m
Insulation	PFA
Outer Sleeve	Polyester
Screened Construction	Yes (Cable screen connected to backshells)
Additional Braided Sleeve	Yes
Cable O/D	12 mm
Minimum Bend Radius	25 mm
Door Closure Allowance	55mm(see diagram)



50-Pin D-Type Cable Assembly

Product Compatibility

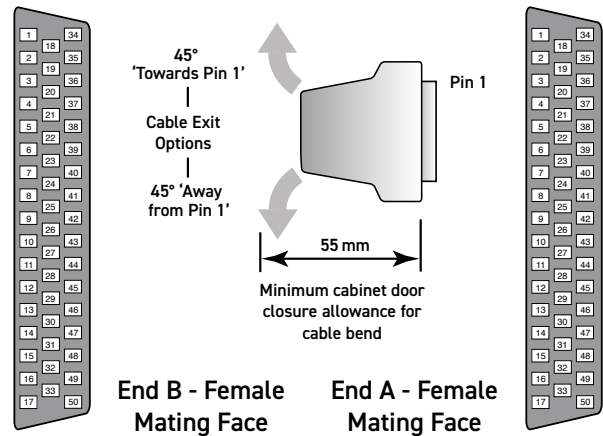
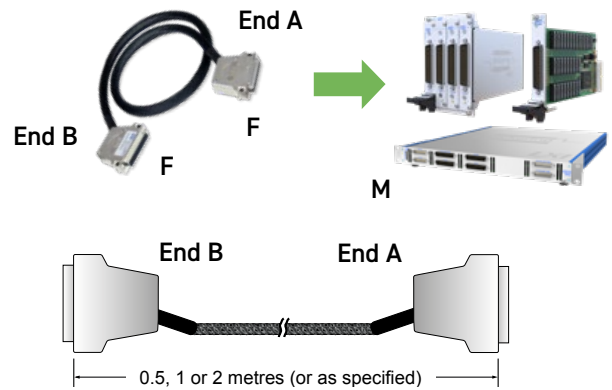

Characteristic Plots for 40-970-050-1m

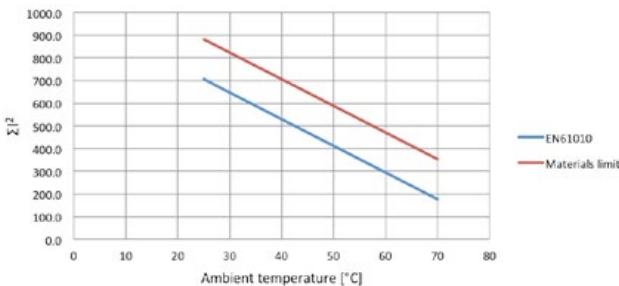

The graph shows the permitted ΣI^2 versus ambient temperature in accordance with EN61010 for user exposure to surface temperature and a higher limit imposed by the materials used where the cable is not directly user accessible.

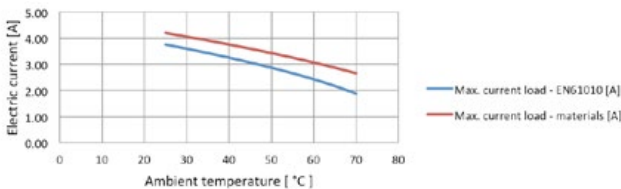

The graph shows the allowed current versus temperature assuming ALL wires carry the same current. Higher currents to the cable rating are permitted on individual wires provided the ΣI^2 is complied with.

Product Order Codes

50-Pin D-Type Cable Assy, 5 A, Female to Female,
 Cable Exit 45° (Away from Pin 1),
 0.5 m Long 40-970-050-0.5m-FF
 1.0 m Long 40-970-050-1m-FF
 2.0 m Long 40-970-050-2m-FF

Cable Exit 45° (Towards Pin 1),
 0.5 m Long A050DF5-050DF5-0A050
 1.0 m Long A050DF5-050DF5-0A100
 2.0 m Long A050DF5-050DF5-0A200

Note: Other cable lengths can be supplied. Max length 5m

- High Specification, Highly Flexible Cable
- Fully Screened Cable Construction with Strain Relief
- Fully Coded Markers to Ensure Easy Connection

Technical Specification

Connector Type (End A):	50-Pin D-Subminiature
Gender	Female
Securing Method	4-40 UNC screwlocks, male
Unterminated End (End B):	
Free Wire Length	130 mm nominal
Individual Wire Labelling	To connector pins
Wire End Options	A white/black screen pigtail is also included Ferrules, Tinned, Cut End
Maximum Current	5 A
Maximum Voltage	250 VAC/400 VDC
Insulation Resistance	1000 M Ω
Connector:	
Contact Material	Gold plated copper alloy
Contact Resistance	<20 m Ω
Cable Exit	45° (See Order Codes)
Overall Size (Approx)	H68 x W18.5 x D55 mm
Cable Type:	Individual wires, screened & sleeved
Conductor:	
Material	Copper
Strands	19/0.18 (0.41mm ² , 21AWG)
Resistance	0.041 Ω /m (max)
Insulation	PFA
Outer Sleeve	Polyester
Screened Construction	Yes (Cable screen connected to backshell)
Additional Braided Sleeve	Yes
Cable O/D	12 mm
Minimum Bend Radius	25 mm
Door Closure Allowance	55 mm(see diagram)

Note: When using this product please ensure appropriate electrical safety.

Characteristic Plots for 40-972-050-1m

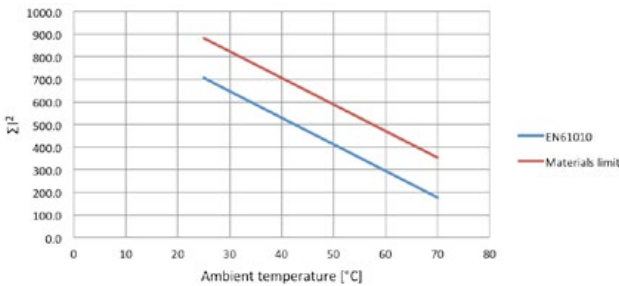

The graph shows the permitted ΣI^2 versus ambient temperature in accordance with EN61010 for user exposure to surface temperature and a higher limit imposed by the materials used where the cable is not directly user accessible.

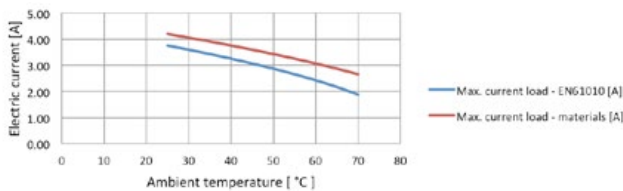

The graph shows the allowed current versus temperature assuming ALL wires carry the same current. Higher currents to the cable rating are permitted on individual wires provided the ΣI^2 is complied with.



50-Pin D-Type Unterminated Cable Assembly

Product Compatibility

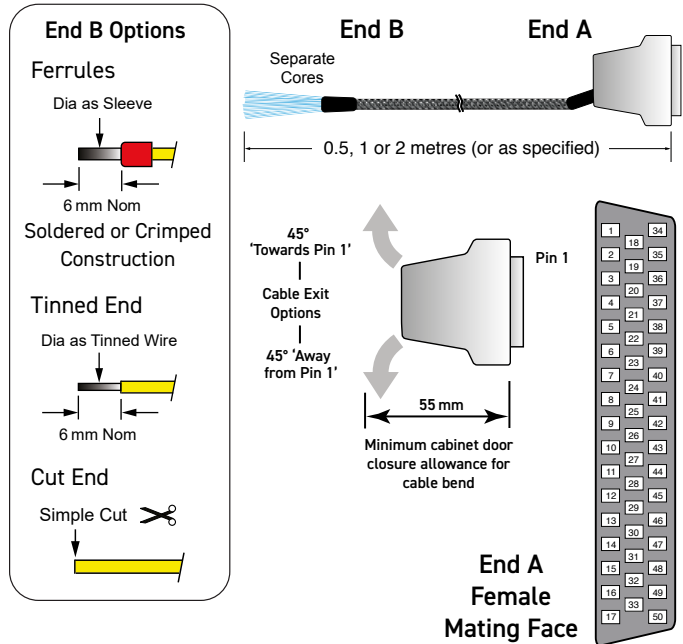
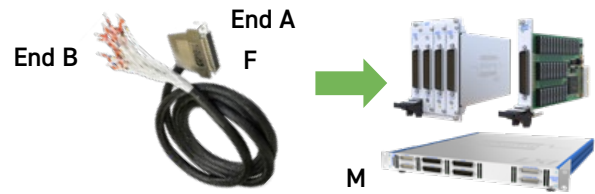

Product Order Codes

- 50-Pin D-Type Cable Assy, 5A, Cable Exit Away from Pin 1, Ferrules, Female to Unterminated, 0.5 m Long **40-972-050-0.5m-FU**
 Female to Unterminated, 1.0 m Long **40-972-050-1m-FU**
 Female to Unterminated, 2.0 m Long **40-972-050-2m-FU**

Part numbers for other versions:

A050DF*-*-0A***

End A: 45° Cable Exit
 4 = (Away from Pin 1)
 5 = (Towards Pin 1)

End B:
 F = Ferrules
 T = Tinned End
 C = Cut End

Cable Length:
 050 = 0.5m
 100 = 1.0m
 200 = 2.0m

Note: Other cable lengths can be supplied. Max length 5m

- Twisted Pair Cable for 41-670 LVDT Simulator
- High Specification, Highly Flexible Cable
- Fully Screened Cable Construction with Strain Relief
- 45° Cable Exit

Technical Specification

Connector Type (End A):	50-Pin D-Subminiature
Gender	Female
Securing Method	4-40 UNC screwlocks, male
Connector Type (End B):	50-Pin D-Subminiature
Gender	Male
Securing Method	4-40 UNC screwlocks, male
Maximum Current	5 A
Maximum Voltage	250 VAC/400 VDC
Insulation Resistance	1000 MΩ
Connectors:	
Contact Material	Gold plated copper alloy
Contact Resistance	<20 mΩ
Cable Exit	45°
Overall Size (Approx)	H68 x W18.5 x D55 mm
Cable Type:	Twisted pairs, screened & sleeved
Conductor: Material	Copper
Strands	19/0.13 (0.2mm ² , 24AWG)
Resistance	0.08 Ω/m (max)
Insulation	EFTE
Outer Sleeve	Polyester
Screened Construction	Yes (Cable screen connected to backshells)
Additional Braided Sleeve	Yes
Cable O/D	14 mm
Minimum Bend Radius	30 mm
Door Closure Allowance	60 mm



50-Pin D-Type Twisted Pair Cable Assembly

Product Compatibility

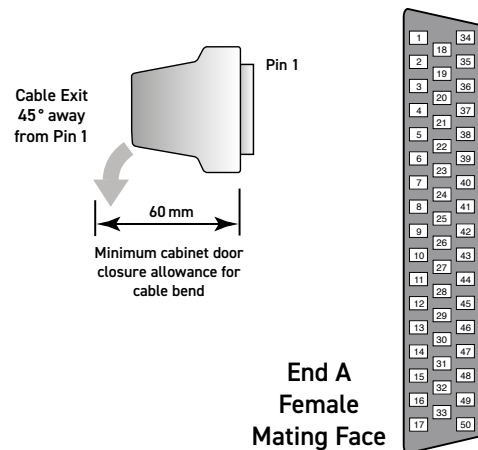
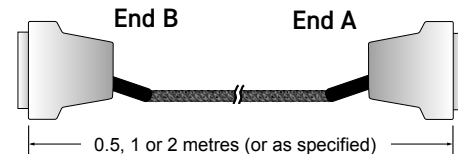
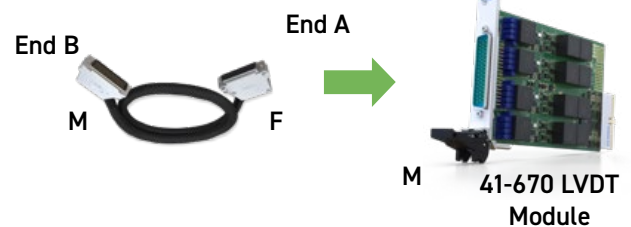

Product Order Codes

50-Pin D-Type Twisted Pair Cable Assy, 5 A, Male to Female
Cable Exit 45° (Away from Pin 1)

0.5 m Long	A050DM4-050DF4-TA050
1.0 m Long	A050DM4-050DF4-TA100
2.0 m Long	A050DM4-050DF4-TA200

Note: Other cable lengths can be supplied. Max length 5 m

- Twisted Pair Cable for 41-670 LVDT Simulator
- High Specification, Highly Flexible Cable
- Fully Screened Cable Construction with Strain Relief
- 45° Cable Exit



50-Pin D-Type Unterminated Twisted Pair Cable Assembly

Technical Specification

Connector Type (End A):	50-Pin D-Subminiature
Gender	Female
Securing Method	4-40 UNC screwlocks, male
Unterminated End (End B):	
Free Wire Length	130 mm nominal
Individual Wire Labelling	To connector pins A white/black screen pigtail is also included
Wire End Options	Cut End
Maximum Current	5 A
Maximum Voltage	250 VAC/400 VDC
Insulation Resistance	1000 MΩ
Connectors:	
Contact Material	Gold plated copper alloy
Contact Resistance	<20 mΩ
Cable Exit	45°
Overall Size (Approx)	H68 x W18.5 x D55 mm
Cable Type:	Twisted pairs, screened & sleeved
Conductor: Material	Copper
Strands	19/0.13 (0.2mm ² , 24AWG)
Resistance	0.08Ω/m (max)
Insulation	EFTE
Outer Sleeve	Polyester
Screened Construction	Yes (Cable screen connected to backshells)
Additional Braided Sleeve	Yes
Cable O/D	14 mm
Minimum Bend Radius	30 mm
Door Closure Allowance	60 mm

Product Compatibility

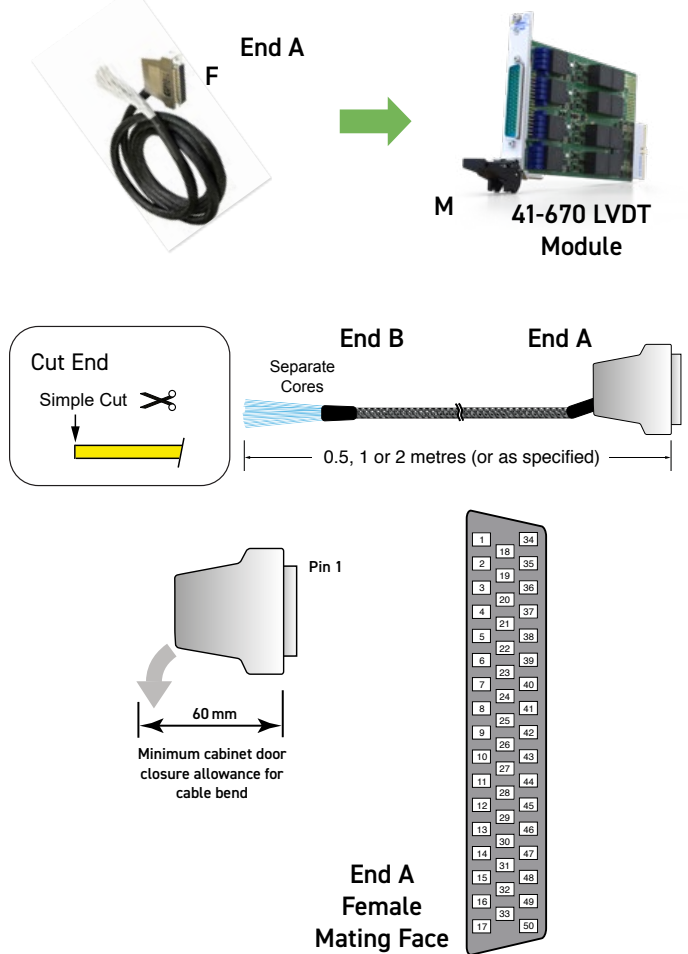

Product Order Codes

50-Pin D-Type Twisted Pair Cable Assy, 5 A, Female to Unterminated, Cut End. Cable Exit 45° (Away from Pin 1)

0.5 m Long [A050DF4-C-TA050](#)

1.0 m Long [A050DF4-C-TA100](#)

2.0 m Long [A050DF4-C-TA200](#)

Note: Other cable lengths can be supplied. Max length 5 m

50-Pin D-Type Underterminated Twisted Pair Cable Assembly

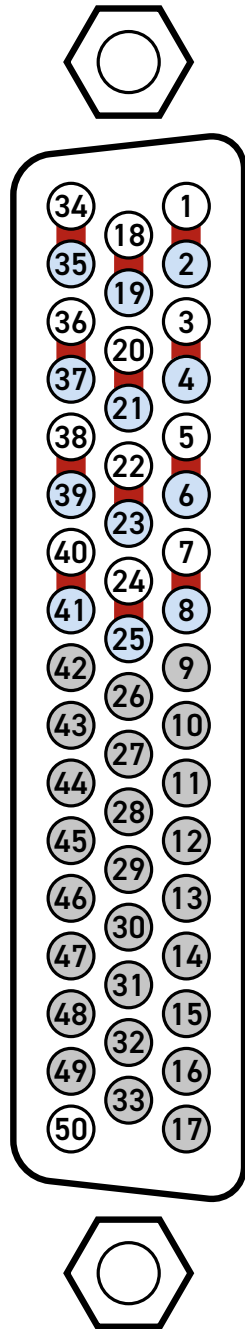

Paired Pins	Wire Color	Signal Path
1	White	IN_S_1
2	White/Blue	IN_G_1
3	White	IN_S_2
4	White/Blue	IN_G_2
5	White	IN_S_3
6	White/Blue	IN_G_3
7	White	IN_S_4
8	White/Blue	IN_G_4
18	White	OUTA_S_1
19	White/Blue	OUTA_G_1
20	White	OUTA_S_2
21	White/Blue	OUTA_G_2
22	White	OUTA_S_3
23	White/Blue	OUTA_G_3
24	White	OUTA_S_4
25	White/Blue	OUTA_G_4
34	White	OUTB_S_1
35	White/Blue	OUTB_G_1
36	White	OUTB_S_2
37	White/Blue	OUTB_G_2
38	White	OUTB_S_3
39	White/Blue	OUTB_G_3
40	White	OUTB_S_4
41	White/Blue	OUTB_G_4
50	White	GND

- Note 1. Red links indicate twisted pairing, ie 1 & 2 use paired wires.
- 2. The cable screen is connected to the connector backshell at end A.

- Connector & PCB Only or Connector, PCB & Backshell
- Male Screwlocks
- Easy to Use Rising Cage Screw Terminals

Connector blocks provide a convenient method of termination without the use of custom cabling. However, a higher resistance path, lower capacity ratings and lower voltage ratings are typical.

The screw terminals use a rising cage clamp mechanism to minimize risk of copper strand breakage. PTFE cables are recommended for use with this connector block to maximise copper cross-sectional area and insulation properties. The breakdown voltage of the connector block is controlled by clearances to the metal shell. The metal shell includes an internal insulation barrier under the carrier board.

This connector block uses male screwlocks and will not mate to Pickering cables. Connector blocks supplied without a backshell do not include cable strain relief.

Technical Specification

Connector Type:	50-Pin D-Subminiature
Gender	Female
Securing Method:	
Product with Backshell	4-40 UNC screwlocks, male
Product without Backshell	4-40 UNC screwlocks, male or female
Wire Connection	Rising cage screw terminals
	A screen (GND) connection is provided
Connector Block Ratings:	
Maximum Current	5 A
Maximum Voltage	200 VDC
Cable Exit	Rear - 15.3 x 30 mm
Overall Size (Approx)	H68 x W18.3 x D102 mm
50-Pin D-Sub:	
Contact Material	Gold plated copper alloy
Contact Resistance	<20 mΩ
Screw Terminals:	
Maximum Wire Size	20 AWG
Recommended Insulation	PTFE
Additional Cable Clamp	Yes (in backshell)

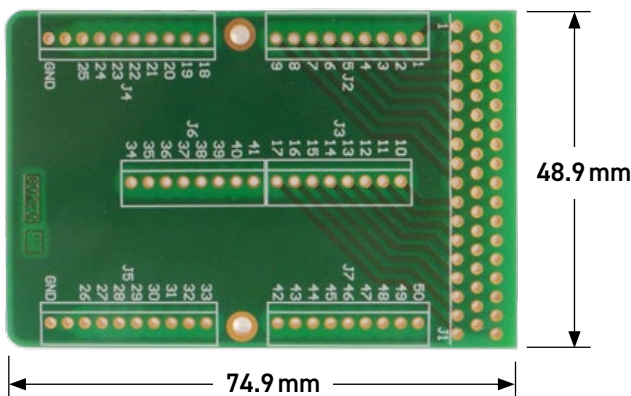

PCB Legend and Dimensions



50-Pin D-Type Connector Block

Product Compatibility

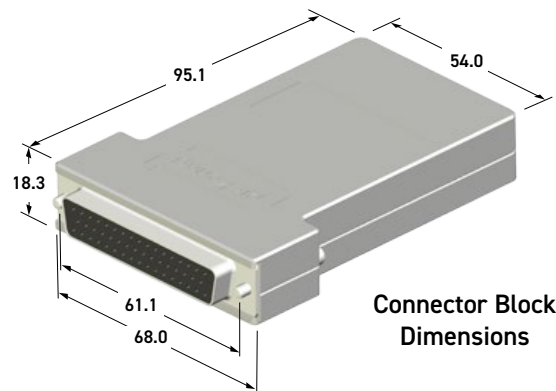
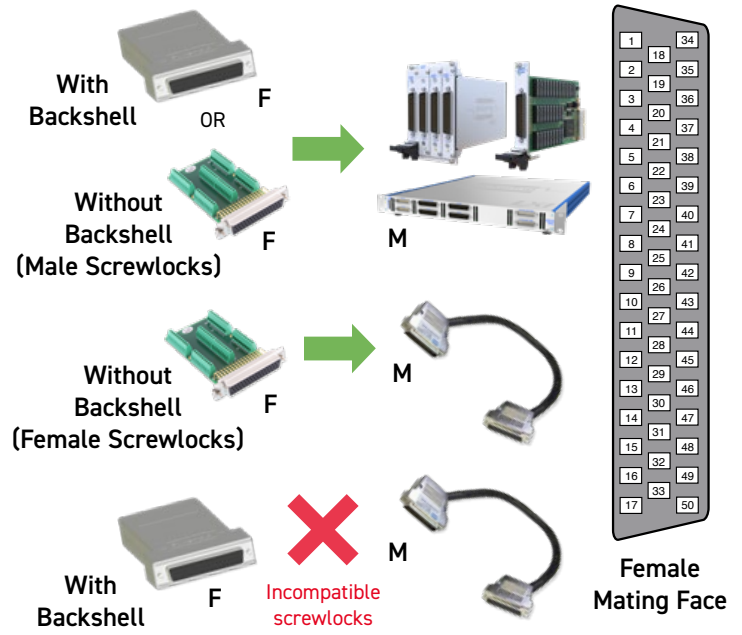

Connector Block Dimensions

Product Order Codes

- 50-Pin D-Type Shielded Connector Block, 5 A, Screw Terminal, With Backshell, Female [40-965A-050-F](#)
- Screw Terminal, Without Backshell, Female [92-965-050-F](#)
- Spare 4-40 UNC Male 27.2 mm Screwlock [40-969-108](#)

Note: Male and female screwlocks are provided for connector blocks without a backshell.

- For Connection at Cable End
- Simple to Use Rising Cage Screw Clamp Termination
- DIN Rail Mounted

Connector blocks provide a convenient method of termination without the use of custom cabling. However, a higher resistance path, lower capacity ratings and lower voltage ratings are typical.

This termination option is capable of accepting heavy duty connection wires and uses rising clamp screw terminals to minimize the danger of copper strand damage. Users should care take to protect the termination and provide a suitable method of restraining the cables.

When using this product please ensure appropriate electrical safety precautions are observed.



50-Pin D-Type Breakout

Technical Specification

Connector Type:	50-Pin D-Subminiature
Gender	Female
Securing Method:	4-40 UNC screwlocks, female
Wire Connection	Rising cage screw terminals A screen connection is provided
Breakout Ratings:	
Maximum Current	5 A
Maximum Voltage	200 VDC
Securing Method	Suitable for securing to DIN rails
Overall Size (Approx)	H110 x W110 x D56 mm
50-Pin D-Sub:	
Contact Material	Gold plated copper alloy
Contact Resistance	<20 mΩ
Screw Terminals:	
Maximum Wire Size	12 AWG
Additional Cable Clamp	No

Product Compatibility

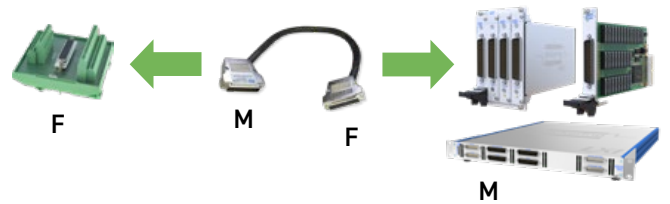

Female Mating Face

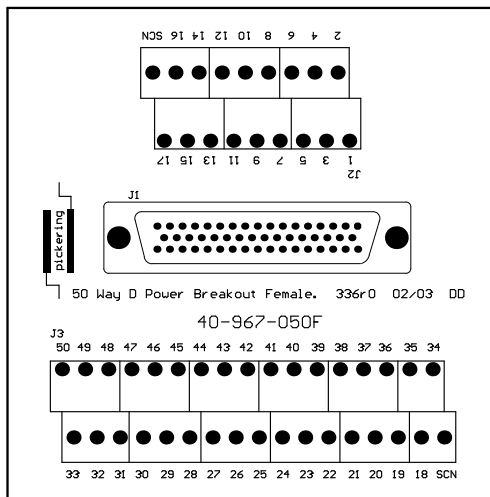

PCB Layout

Product Order Codes

50-Pin D-Type Breakout with DIN Rail Mount, 5 A,
Screw Terminal, Female [40-967-050-F](#)

- Connector only or Connector and Backshell
- Cable Clamp in Backshell
- Soldered Cable Termination

This accessory is designed to allow users to directly terminate with soldered connections to the connector.

Connector and shell are supplied separately to allow the user to determine the direction of the cable exit.

When the product is used without a backshell users should make their own cable strain relief arrangements and ensure appropriate electrical safety precautions are observed.



50-Pin D-Type Cable Connector

Technical Specification

Connector Type:	50-Pin D-Subminiature
Gender	Female
Securing Method:	
Product with Backshell	4-40 UNC screwlocks, male
Product without Backshell	4-40 UNC screwlocks, male
Wire Connection	Solder bucket. A backshell fixing is also provided for a cable screen
Connector Ratings:	
Maximum Current	5 A
Maximum Voltage	250 VAC
Cable Exit:	45°
Cable Exit Size	15 mm dia
Overall Size (Approx)	H68 x W18.5 x D55 mm
50-Pin D-Sub:	
Contact Material	Gold plated copper alloy
Contact Resistance	20 mΩ
Wire Connection:	
Maximum Wire Size	20 AWG
Recommended Insulation	PTFE
Additional Cable Clamp	Yes (in backshell)

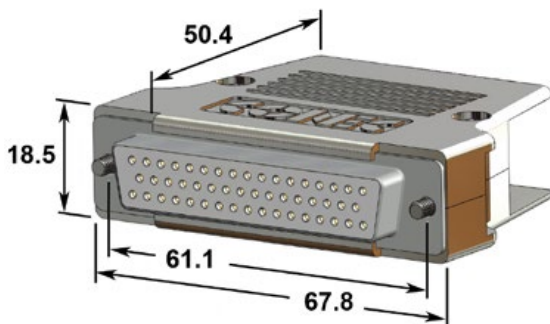

Connector Dimensions

Product Compatibility

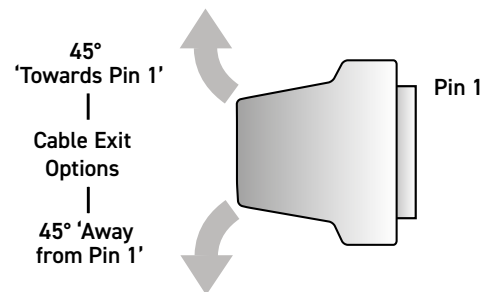
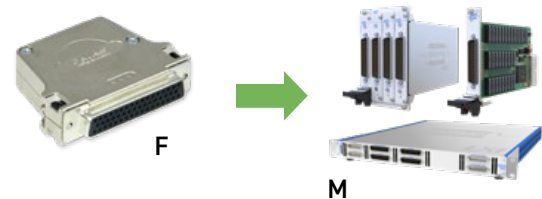

Internal Solder Connection

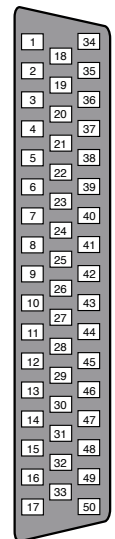

Female Mating Face

Product Order Codes

50-Pin D-Type Connector, 5 A, Solder Bucket, With Backshell, Female	40-960-050-F
Without Backshell, Female	92-960-050-F

- Right Angle PCB Mount
- Ideal for User Created Termination Solutions

This accessory allows a user to create their own PCB based termination solution mounted on the end of a cable. Suitable cables for this product are contained elsewhere in this data sheet. Interfacing PCBs should be designed with suitable clearances for the voltage the application requires.

Note: This product is not suitable for directly mounting onto the front panel of a Pickering switching product.

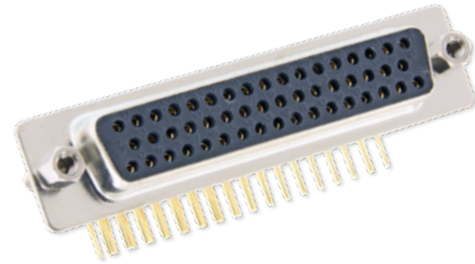

50-Pin D-Type PCB Connector

Product Compatibility

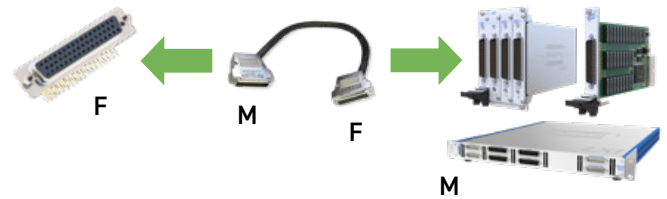

Technical Specification

Connector Type:	50-Pin D-Subminiature
Gender	Female
Securing Method	4-40 UNC screwlocks, female
PCB Mounting	Right angle PCB mount, solder
Connector Ratings:	
Maximum Current	5 A each pin
Maximum Voltage	250 VAC
50-Pin D-Sub:	
Contact Material	Gold plated copper alloy
Contact Resistance	<20 mΩ
PCB Legs:	
Effective Leg Length	3.6 mm nom (See diagram)

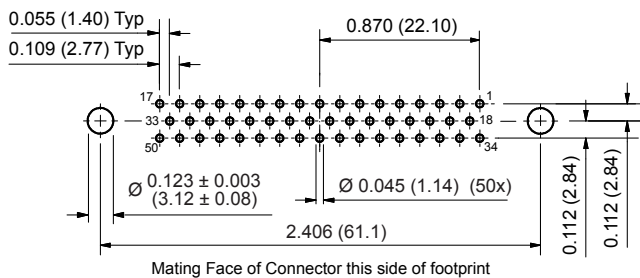

PCB Footprint of 50-Pin Right Angle Female Connector
(Connector Side - Not to Scale)

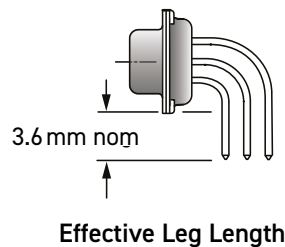

Female Mating Face

Product Order Codes

50-Pin D-Type Connector, 5 A, Right Angle PCB Mount, Female
[40-963-050-RF](#)

- Straight PCB Mount
- Ideal for User Created Termination Solutions

This accessory allows a user to create their own PCB based termination solution mounted on the end of a cable. Suitable cables for this product are contained elsewhere in this data sheet. Interfacing PCBs should be designed with suitable clearances for the voltage the application requires.

Note: This product is not suitable for directly mounting onto the front panel of a Pickering switching product.

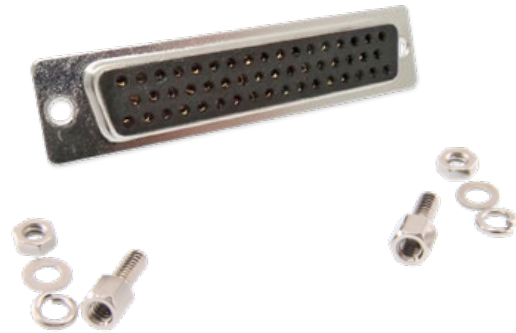

50-Pin D-Type PCB Connector

Technical Specification

Connector Type:	50-Pin D-Subminiature
Gender	Female
Securing Method	4-40 UNC screwlocks, female
PCB Mounting	Straight PCB mount, solder
Connector Ratings:	
Maximum Current	5 A each pin
Maximum Voltage	250 VAC
50-Pin D-Sub:	
Contact Material	Gold plated copper alloy
Contact Resistance	<20 mΩ
PCB Legs:	
Leg Length	3.8 mm nom (See diagram)

Product Compatibility

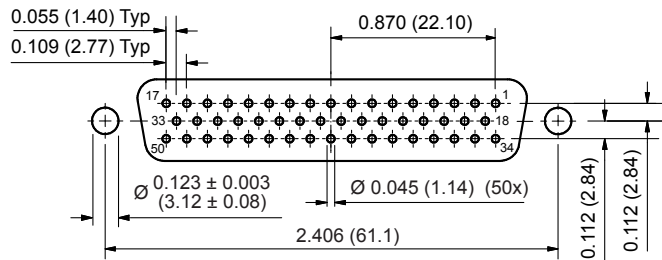
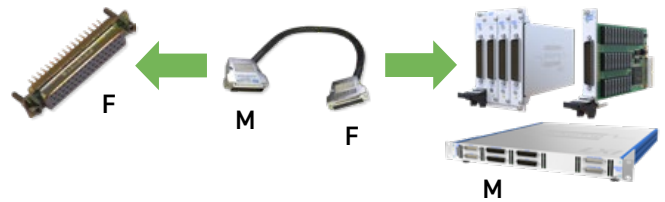

PCB Footprint of 50-Pin Straight Female Connector
(Connector Side - Not to Scale)

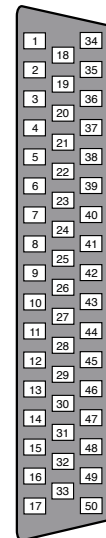
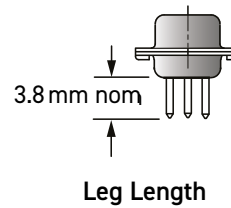

Female Mating Face

Product Order Codes

50-Pin D-Type Connector, 5A, Straight PCB Mount,
Female [40-963-050-SF](#)

- For Connection at Cable End
- Simple to Use Rising Cage Screw Clamp Termination
- DIN Rail Mounted

Connector blocks provide a convenient method of termination without the use of custom cabling. However, a higher resistance path, lower capacity ratings and lower voltage ratings are typical.

This termination option is capable of accepting heavy duty connection wires and uses rising clamp screw terminals to minimize the danger of copper strand damage. Users should care take to protect the termination and provide a suitable method of restraining the cables.

When using this product please ensure appropriate electrical safety precautions are observed.

Technical Specification

Connector Type:	50-Pin D-Subminiature
Gender	Male
Securing Method:	4-40 UNC screwlocks, female
Wire Connection	Rising cage screw terminals A screen connection is provided
Breakout Ratings:	
Maximum Current	5 A
Maximum Voltage	200 VDC
Securing Method	Suitable for securing to DIN rails
Overall Size (Approx)	H110 x W110 x D56 mm
50-Pin D-Sub:	
Contact Material	Gold plated copper alloy
Contact Resistance	<20 mΩ
Screw Terminals:	
Maximum Wire Size	12 AWG
Additional Cable Clamp	No

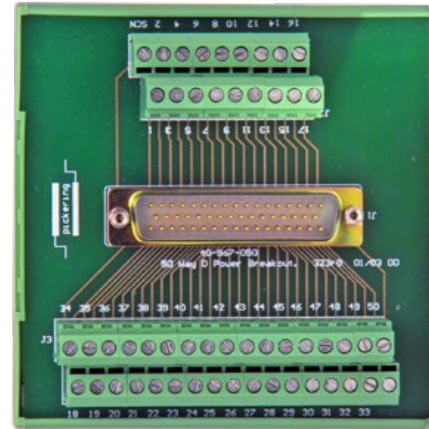

50-Pin D-Type Breakout

Product Compatibility

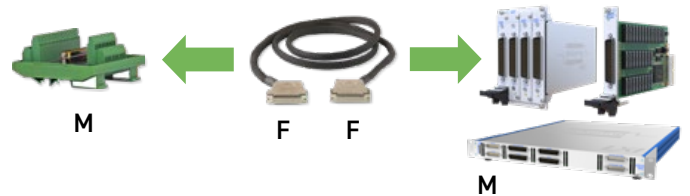

Male Mating Face

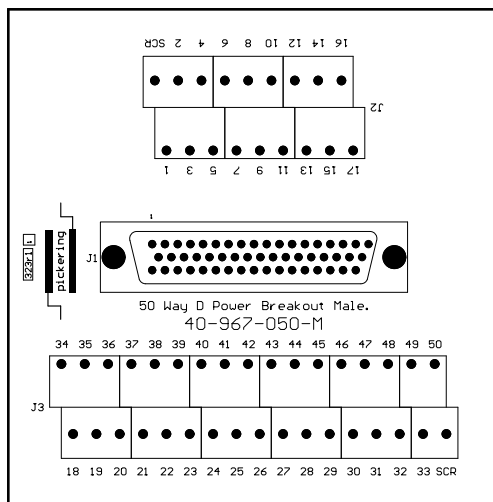

PCB Layout

Product Order Codes

50-Pin D-Type Breakout with DIN Rail Mount, 5 A,
Screw Terminal, Male [40-967-050-M](#)

- Right Angle PCB Mount
- Ideal for User Created Termination Solutions

This accessory allows a user to create their own PCB based termination solution mounted on the end of a cable. Suitable cables for this product are contained elsewhere in this data sheet. Interfacing PCBs should be designed with suitable clearances for the voltage the application requires.

Note: This product is not suitable for directly mounting onto the front panel of a Pickering switching product.



50-Pin D-Type PCB Connector

Product Compatibility



Technical Specification

Connector Type:	50-Pin D-Subminiature
Gender	Male
Securing Method	4-40 UNC screwlocks, female
PCB Mounting	Right angle PCB mount, solder
Connector Ratings:	
Maximum Current	5 A each pin
Maximum Voltage	250 VAC
50-Pin D-Sub:	
Contact Material	Gold plated copper alloy
Contact Resistance	<20 mΩ
PCB Legs:	
Effective Leg Length	3.6 mm nom (See diagram)

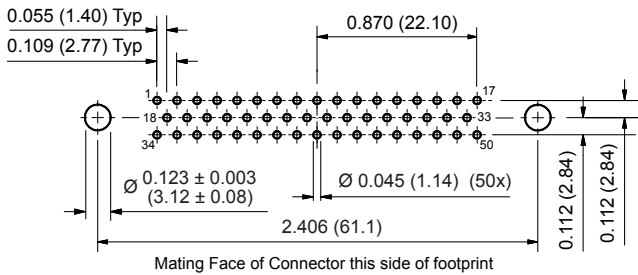
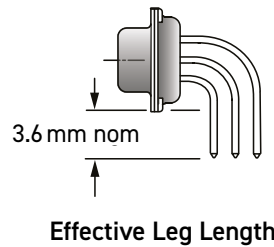

PCB Footprint of 50-Pin Right Angle Male Connector
(Connector Side - Not to Scale)

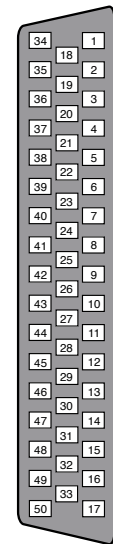

Male Mating Face

Product Order Codes

50-Pin D-Type Connector, 5 A, Right Angle PCB Mount, Male [40-963-050-RM](#)

- Straight PCB Mount
- Ideal for User Created Termination Solutions

This accessory allows a user to create their own PCB based termination solution mounted on the end of a cable. Suitable cables for this product are contained elsewhere in this data sheet. Interfacing PCBs should be designed with suitable clearances for the voltage the application requires.

Note: This product is not suitable for directly mounting onto the front panel of a Pickering switching product.



50-Pin D-Type PCB Connector

Product Compatibility

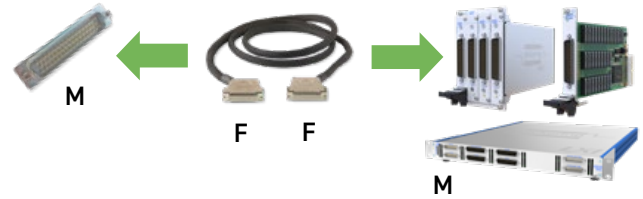

Technical Specification

Connector Type:	50-Pin D-Subminiature
Gender	Male
Securing Method	4-40 UNC screwlocks, female
PCB Mounting	Straight PCB mount, solder
Connector Ratings:	
Maximum Current	5 A each pin
Maximum Voltage	250 VAC
50-Pin D-Sub:	
Contact Material	Gold plated copper alloy
Contact Resistance	<20 mΩ
PCB Legs:	
Leg Length	3.8 mm nom (See diagram)

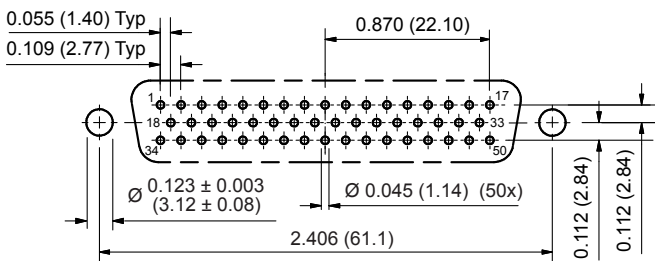

PCB Footprint of 50-Pin Straight Male Connector
(Connector Side - Not to Scale)

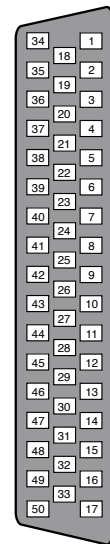
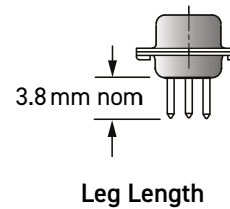

Male Mating Face

Product Order Codes

50-Pin D-Type Connector, 5 A, Straight PCB Mount, Male **40-963-050-SM**

Additional Connection Accessories

Although these items do not directly mate with Pickering Interfaces products customers may find them useful in the development of their own connection solutions.

- High Specification, Highly Flexible Cable
- Fully Screened Cable Construction with Strain Relief
- 45° Cable Exit

Technical Specification

Connector Type (End A):	50-Pin D-Subminiature
Gender	Male
Securing Method	4-40 UNC screwlocks, male
Connector Type (End B):	50-Pin D-Subminiature
Gender	Male
Securing Method	4-40 UNC screwlocks, male
Maximum Current	5 A
Maximum Voltage	250 VAC/400 VDC
Insulation Resistance	1000 MΩ
Connectors:	
Contact Material	Gold plated copper alloy
Contact Resistance	<20 mΩ
Cable Exit	45° (See Order Codes)
Overall Size (Approx)	H68 x W18.5 x D55 mm
Cable Type:	Individual wires, screened & sleeved
Conductor: Material	Copper
Strands	19/0.18 (0.41mm ² , 21AWG)
Resistance	0.041Ω/m
Insulation	PFA
Outer Sleeve	Polyester
Screened Construction	Yes (Cable screen connected to backshells)
Additional Braided Sleeve	Yes
Cable O/D	12 mm
Minimum Bend Radius	25 mm
Door Closure Allowance	55 mm(see diagram)

This Cable Assembly is Not Suitable for Connection to a Pickering Switching Product

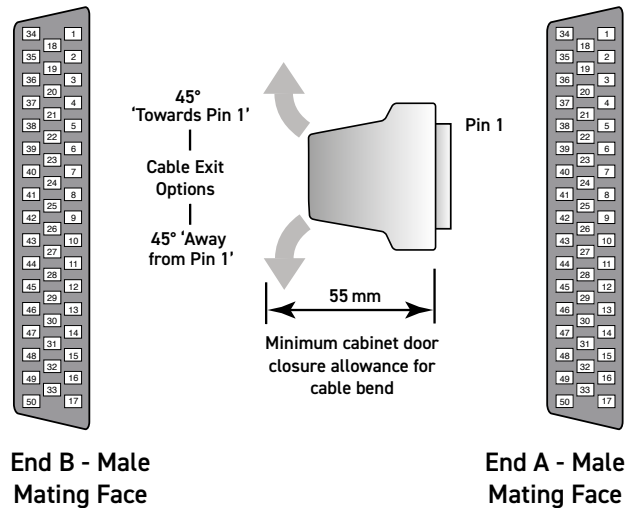
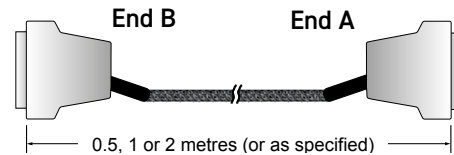
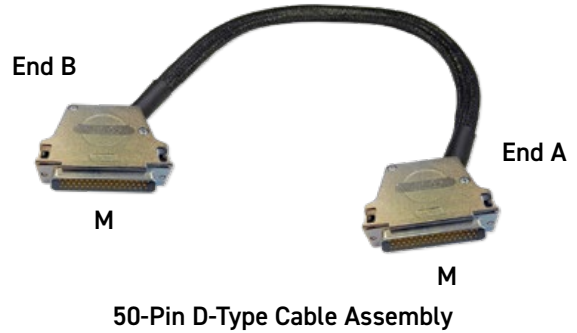

Characteristic Plots for 40-970-050-1m

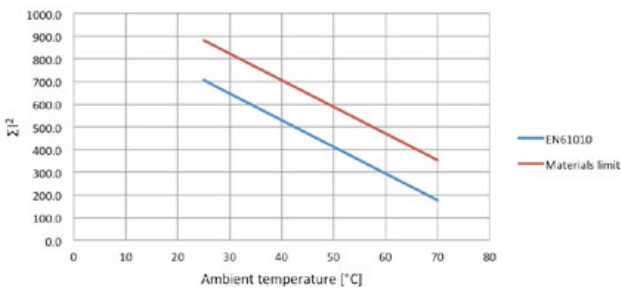

The graph shows the permitted ΣI^2 versus ambient temperature in accordance with EN61010 for user exposure to surface temperature and a higher limit imposed by the materials used where the cable is not directly user accessible.

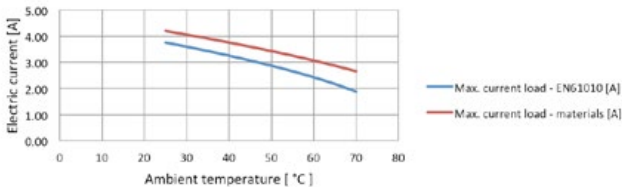

The graph shows the allowed current versus temperature assuming ALL wires carry the same current. Higher currents to the cable rating are permitted on individual wires provided the ΣI^2 is complied with.

Product Order Codes

50-Pin D-Type Cable Assy, 5 A, Male to Male, Cable Exit 45° (Away from Pin 1),

- 0.5 m Long [40-970-050-0.5m-MM](#)
- 1.0 m Long [40-970-050-1m-MM](#)
- 2.0 m Long [40-970-050-2m-MM](#)

Cable Exit 45° (Towards Pin 1),

- 0.5 m Long [A050DM5-050DM5-0A050](#)
- 1.0 m Long [A050DM5-050DM5-0A100](#)
- 2.0 m Long [A050DM5-050DM5-0A200](#)

- Note:** 1. The Male gender **Will Not Mate** with a Pickering Module.
2. Other cable lengths can be supplied. Max length 5 m

- High Specification, Highly Flexible Cable
- Fully Screened Cable Construction with Strain Relief
- Fully Coded Markers to Ensure Easy Connection

Technical Specification

Connector Type (End A):	50-Pin D-Subminiature
Gender	Male
Securing Method	4-40 UNC screwlocks, male
Unterminated End (End B):	
Free Wire Length	130 mm nominal
Individual Wire Labelling	To connector pins. A white/black screen pigtail is also included
Wire End Options	Ferrules, Tinned, Cut End
Maximum Current	5 A
Maximum Voltage	250 VAC/400 VDC
Insulation Resistance	1000 MΩ
Connector:	
Contact Material	Gold plated copper alloy
Contact Resistance	<20 mΩ
Cable Exit	45° (See Order Codes)
Overall Size (Approx)	H68 x W18.5 x D55 mm
Cable Type:	Individual wires, screened & sleeved
Conductor:	
Material	Copper
Strands	19/0.18 (0.41mm ² , 21AWG)
Resistance	0.041Ω/m (max)
Insulation	PFA
Outer Sleeve	Polyester
Screened Construction	Yes (Cable screen connected to backshell)
Additional Braided Sleeve	Yes
Cable O/D	12 mm
Minimum Bend Radius	25 mm
Door Closure Allowance	55 mm(see diagram)

Note: When using this product please ensure appropriate electrical safety.

Characteristic Plots for 40-972-050-1m

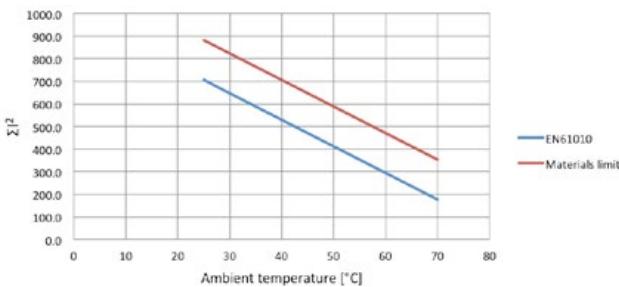

The graph shows the permitted ΣI^2 versus ambient temperature in accordance with EN61010 for user exposure to surface temperature and a higher limit imposed by the materials used where the cable is not directly user accessible.

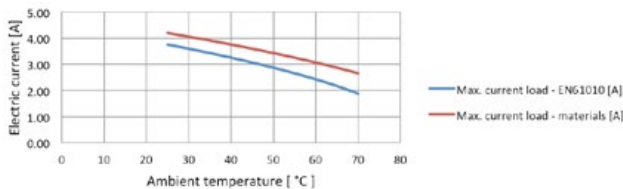

The graph shows the allowed current versus temperature assuming ALL wires carry the same current. Higher currents to the cable rating are permitted on individual wires provided the ΣI^2 is complied with.

This Cable Assembly is Not Suitable for Connection to a Pickering Switching Product

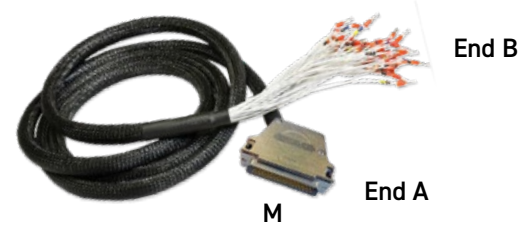

50-Pin D-Type Unterminated Cable Assembly

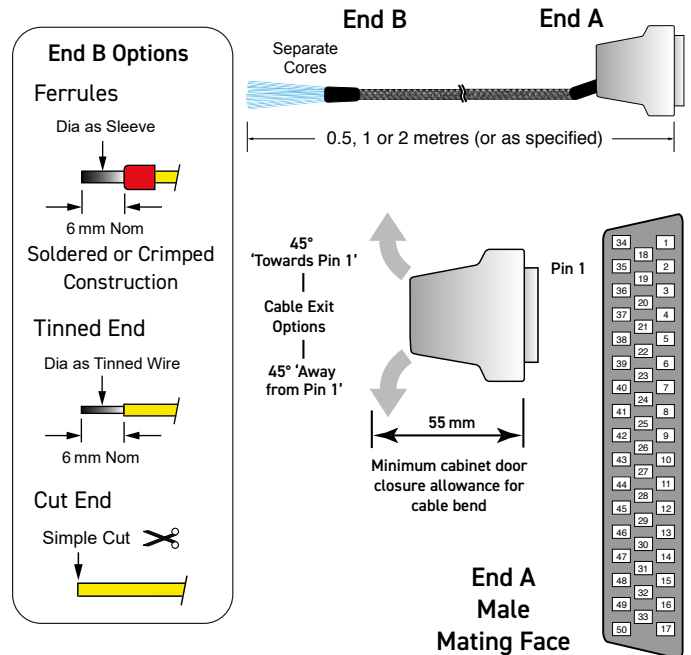

Product Order Codes

- 50-Pin D-Type Cable Assy, 5A, Cable Exit Away from Pin 1, Ferrules,
- Female to Unterminated, 0.5 m Long [40-972-050-0.5m-MU](#)
 - Female to Unterminated, 1.0 m Long [40-972-050-1m-MU](#)
 - Female to Unterminated, 2.0 m Long [40-972-050-2m-MU](#)

Part numbers for other versions:

A050DM*-*-0A***

End A: 45° Cable Exit
4 = (Away from Pin 1)
5 = (Towards Pin 1)

End B:
F = Ferrules
T = Tinned End
C = Cut End

Cable Length:
050 = 0.5 m
100 = 1.0 m
200 = 2.0 m

Note: 1. The Male gender **Will Not Mate** with a Pickering Module.
2. Other cable lengths can be supplied. Max length 5 m

- Connector only or Connector and Backshell
- Male Screwlocks
- Cable Clamp in Backshell
- Soldered Cable Termination

This accessory is designed to allow users to directly terminate with soldered connections to the connector.

Connector and shell are supplied separately to allow the user to determine the direction of the cable exit.

When the product is used without a backshell users should make their own cable strain relief arrangements and ensure appropriate electrical safety precautions are observed.

Technical Specification

Connector Type:	50-Pin D-Subminiature
Gender	Male
Securing Method:	
Product with Backshell	4-40 UNC screwlocks, male
Product without Backshell	4-40 UNC screwlocks, male
Wire Connection	Solder bucket. A backshell fixing is also provided for a cable screen
Connector Ratings:	
Maximum Current	5 A
Maximum Voltage	250 VAC
Cable Exit:	45°
Cable Exit Size	15mm dia
Overall Size (Approx)	H68 x W18.5 x D55mm
50-Pin D-Sub:	
Contact Material	Gold plated copper alloy
Contact Resistance	20 mΩ
Wire Connection:	
Maximum Wire Size	20 AWG
Recommended Insulation	PTFE
Additional Cable Clamp	Yes (in backshell)

This Connector is Not Suitable for Connection to a Pickering Switching Product



M

50-Pin D-Type Connector with Backshell

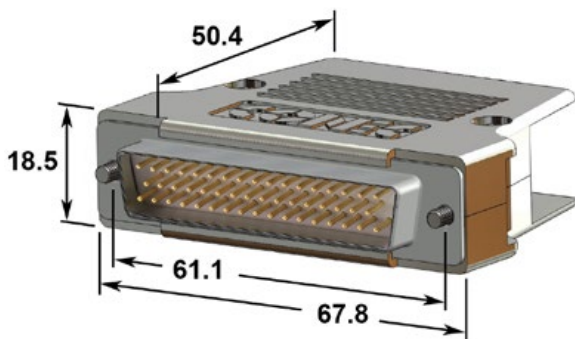
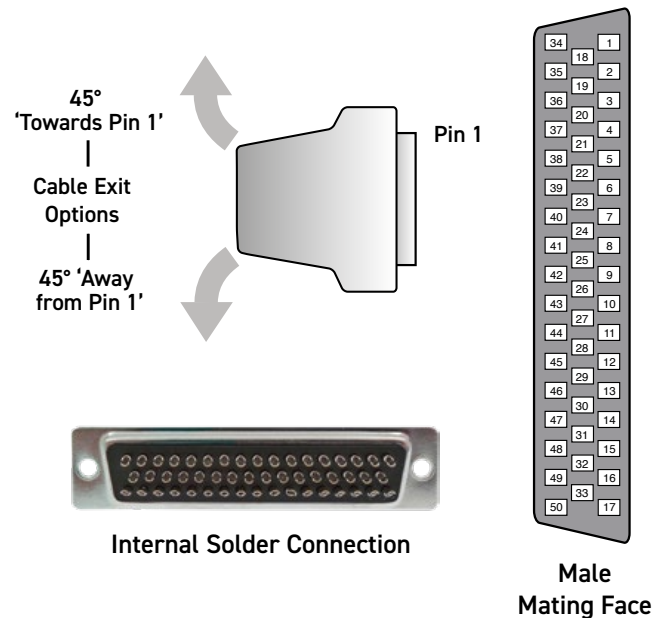

Connector Dimensions

Product Order Codes

- 50-Pin D-Type Connector, 5 A, Solder Bucket, With Backshell, Male [40-960-050-M](#)
- Without Backshell, Male [92-960-050-M](#)

Note: The Male gender **Will Not Mate** with a Pickering Module.

- Cable Support for Rack Mounted LXI Modules
- Sturdy Blue Anodized Aluminium Support Bar
- Slotted for Cable Suspension Using Straps
- 50 mm, 75 mm or 100 mm Deep
- Additional Support Pillars Available

Suitable cable support ensures connection reliability for rack systems by maintaining minimum bend radii of cables and relieving undue strain on connectors and screwlocks. Pickering recommends the use of cable support for all rack mounted applications.

The 63-970 Rack Mount Cable Management Bar Kit provides a robust support system for cables and connectors interfacing with rack mounted LXI modules. It features a sturdy blue anodized aluminium support bar with zinc plated steel support pillars supplied in depths of 50, 75 or 100 mm. Cables can be supported directly on the bar, or suspended with straps from the slots.

Additional pillars are available to create custom depths over 100 mm where required.



Rack Utilizing Cable Support Management Kits



Rack Mount Cable Management Bar Kit (50mm)



Additional Support Pillars

Product Order Codes

Rack Mount Cable Management Bar Kit	
50 mm Deep	63-970-050
75 mm Deep	63-970-075
100 mm Deep	63-970-100
Additional Support Pillars (x2)	
2 x 50 mm Deep	63-960-050
2 x 75 mm Deep	63-960-075
2 x 100 mm Deep	63-960-100

Custom Termination

Pickering Interfaces are able to manufacture custom built cable assemblies and backshells that mate with all the connectors we use in our extensive product range and to provide connection solutions for third party products.

We are able to model and manufacture cable assemblies and other termination arrangements to user notes and drawings, and to deal with simple and complex assemblies, and both small and high volume orders.

All products are designed to ensure easy and problem free connection.

We offer a fast turn round of custom items to keep your ordering and integration time scales to a minimum.



Pickering's Cable Design Tool

Our Cable Design Tool is an online tool that allows you to define a cable assembly to exactly meet your requirements.

- Graphical design of customized cable assemblies
- Built-in library of standard cable sets can be used as the basis for customization, or cables can be defined from scratch
- The ability to store cable assemblies in the Cloud and develop them over time
- Each cable design has a PDF documentation file detailing all the specifications
- Allows detailed design including; connector types, wire type, pin definitions, pin & cable labelling, cable bundling, length selection, sleeving, comments, etc.
- Add your own connectors and wires
- Fully supported on major tablet operating systems

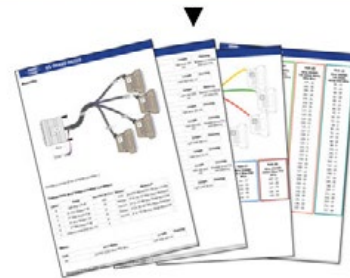
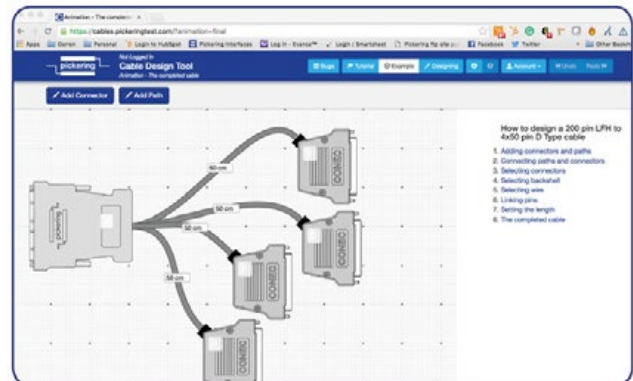

Because the Cable Design Tool is a web-based tool, we will continually update it to better accommodate your requirements and features. Your data is not trapped; complete details of the design are always available to the user at any time via the documentation or spreadsheet file. Once a cable is designed, you can submit it to us for quotation.

For more information visit: pickeringtest.com/cdt