

25 Watt DC-DC Converters

IMS 25 Series

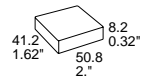
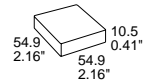
Wide input voltage ranges up to 75 V DC
Single output up to 15 V DC
1500 V DC I/O electric strength test voltage

- Industry standard pin-out
- Fixed frequency operation
- High efficiency up to 90%
- 2" x 1.6" platform with 8.5 mm profile without and 10.5 mm profile with case
- Soft start
- Shut down input, output voltages adjustable
- Programmable input undervoltage lockout
- Outputs no-load, overload and short-circuit proof
- Operating ambient temperature $-40...105^{\circ}\text{C}$
- Thermal protection with auto-reset (non latching)
- Basic insulation
- Immunity to IEC/EN 61000-4-2,-3,-4,-5 and -6

Safety according to IEC/EN 60950, UL 1950



UL US Approvals pending



Summary

The IMS 25 series of board mountable 25 Watt DC-DC converters has been designed according to the latest industry requirements and standards. The converters are particularly suitable for applications in industry and telecommunication where variable input voltages or high transient voltages are prevalent.

Providing two wide input voltage ranges, 14...36 V DC and 32...75 V DC, the units are available with a single output voltage from 2.5 V DC up to 16.5 V DC externally adjustable. A shut down input allows remote converter on/off. Features include efficient input and output filtering with unsurpassed transient and surge protection, low output ripple and noise, consistently high efficiency over the entire input voltage range, high reliability as well as excellent dynamic response to load and line changes.

The converters provide basic insulation with SELV outputs as e.g. required in battery supported systems where the bus voltage may exceed the SELV limit of 60 V DC. They are designed and built according to the international safety standards IEC/EN 60950, UL 1950, CAN/CSA C22.2 No.950-95.

The circuit comprises integrated planar magnetics and all components are automatically assembled and soldered onto a single PCB without any wire connections. The proprietary magnetic feedback solution ensures maximum reliability and repeatability in the control loop over all operating conditions. Careful considerations of possible thermal stresses ensure the absence of hot spots providing long life in environments where temperature cycles are a reality. The thermal design allows operation at full load up to an ambient temperature of 71°C in free air without using any potting material. For extremely high vibration environments the case has holes for screw mounting.

Table of Contents

	Page	Page	
Summary	1	Temperature Derating	5
Type Survey and Key Data	2	Auxiliary Functions	6
Type Key	2	Electromagnetic Compatibility (EMC)	7
Functional Description	2	Immunity to Environmental Conditions	8
Electrical Input Data	3	Mechanical Data	9
Electrical Output Data	4	Safety and Installation Instructions	10
		Description of Option	11

Type Survey and Key Data

Table 1: Type survey

Output 1		Output power $P_{o\ nom}$ [W]	Input Voltage Range and Efficiency				Option
$U_{o1\ nom}$ [V DC]	$I_{o1\ nom}$ [A]		$U_{i\ min...U_{i\ max}}$ 14...36 V DC	η_{typ} [%]	$U_{i\ min...U_{i\ max}}$ 32...75 V DC	η_{typ} [%]	
2.5	6	15	24 IMS 25-2.5-9G	82	48 IMS 25-2.5-9G	85	i Z
3.3	6	19.8	24 IMS 25-03-9G	86	48 IMS 25-03-9G	87	
5.1	5	25.5	24 IMS 25-05-9G	87	48 IMS 25-05-9G	90	
12	2	24	24 IMS 25-12-9	88	48 IMS 25-12-9	89	
15	1.6	24	24 IMS 25-15-9	88	48 IMS 25-15-9	89	

Type Key

Input voltage range U_i

14...36 V DC 24

32...75 V DC 48

Series IMS 25

Output voltage type output 2.5, 03, 05, 12, 15

Operating ambient temperature range T_A (100% load @0 LFM)

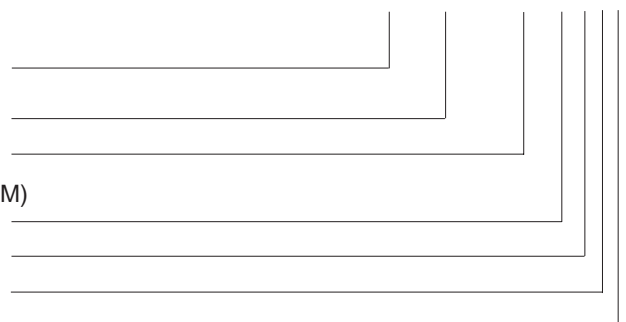
-40...71°C -9

Synchronous rectifier G

Option: Inhibit i

Open frame Z

24 IMS 25 - 2.5 - 9 G i Z



Examples: 48 IMS 25-12-9Z: DC-DC converter, input voltage range 32...75 V, output 12 V, 2 A, no case.

24 IMS 25-2.5-9G: DC-DC converter, input voltage range 14...36 V, output 2.5 V, 6 A.

Functional Description

The IMS 25 series of DC-DC converters are magnetic feedback controlled forward converters using current mode PWM (Pulse Width Modulation). The 2.5, 3.3 and 5.1 V output voltage versions feature a synchronous rectifier resulting in very high efficiency. The output voltage of these versions can be adjusted via the Trim input. The Trim input is referenced to the secondary side and allows for programming of the output voltage in the range of approximately 90 to 110% of $U_{o\ nom}$ using an external resistor.

The voltage regulation is achieved with a magnetic feedback circuit providing excellent line and load regulation.

Current limitation is provided by the primary circuit, thus limiting the total output current to approx. $150\% \cdot I_{o\ nom}$ (see: *Type Survey*). The shut down input allows remote converter on/off.

Overtemperature protection will shut down the unit in excessive overload conditions with automatic restart.

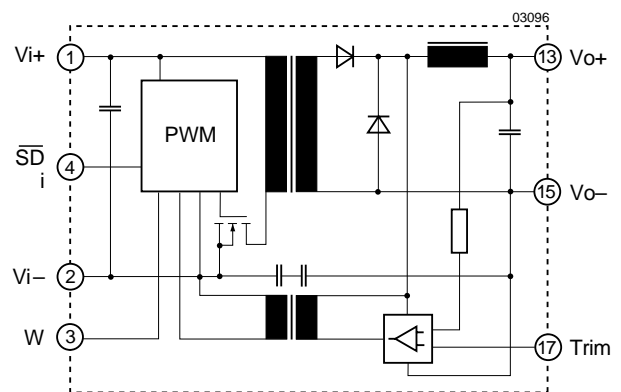


Fig. 1
Block diagram

Electrical Input Data

General conditions:

- $T_A = 25^\circ\text{C}$, unless T_C is specified.
- Shut down pin left open circuit (not connected).
- Trim input not connected.

Table 2: Input Data

Input			24 IMS			48 IMS			
Characteristics		Conditions	min	typ	max	min	typ	max	Unit
U_i	Input voltage range ¹	$T_C \text{ min} \dots T_C \text{ max}$	14 ⁵		36	32		75	V DC
$U_{i \text{ nom}}$	Nominal input voltage	$I_o = 0 \dots I_o \text{ nom}$	24			48			
$U_{i \text{ sur}}$	Repetitive input surge voltage	max 3 s	50			100			
$t_{\text{start up}}$	Converter start-up time	Switch on	0.25		0.5	0.25		0.5	s
		$\overline{\text{SD}}$ high			0.1			0.1	
t_{rise}	Rise time	$U_{i \text{ min}}, I_o = I_o \text{ nom}^2$	5			5			ms
$I_{i \text{ NL}}$	No load input current		$I_o = 0, U_{i \text{ min}} \dots U_{i \text{ max}}$	75	150		40	80	mA
C_i	Input capacitance	for surge calculation	2.0			2.0			μF
$U_{\overline{\text{SD}}}$	Shut down voltage	Unit disabled	-10		0.7	-10		0.7	V DC
		Unit operating	2.0		5.5	2.0		5.5	
$I_{\overline{\text{SD}}}$	Input current of $\overline{\text{SD}}$ input		1	2		1	2	mA	
$I_{\text{inr p}}$	Inrush peak current ⁴	$U_i = U_{i \text{ nom}}$	3			1.5			A
$I_{i \text{ rr}}$	Reflected ripple current	$I_o = 0 \dots I_o \text{ nom}$	100 ³			60			mA_{pp}

¹ $U_{i \text{ min}}$ will not be as stated if U_o is increased above $U_o \text{ nom}$ by use of the Trim input. If the output voltage is set to a higher value, $U_{i \text{ min}}$ will be proportionally increased.

² Measured with a resistive and the max. admissible capacitive load.

³ 24IMS25-12/15 use a 470 μF 50Vdc electrolytic capacitor to achieve less than 30 mA_{pp} (Nichicon TVX1H100MAA or equivalent)

⁴ Source impedance according to prETS 300132-2, version 4.3.

⁵ Linear derating to 85% of $I_o \text{ nom}$ for $U_i < 16.8 \text{ V}$.

Inrush Current

The inrush current has been kept as low as possible by choosing a very small input capacitance.

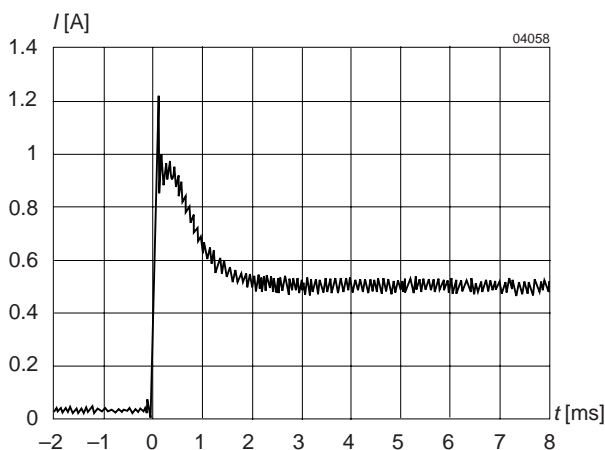


Fig. 2

Typical inrush current at $U_{i \text{ nom}}, P_o \text{ nom}$ versus time (48 IMS 25-05-9G). Source impedance according to prETS 300132-2, version 4.3 at $U_{i \text{ nom}}$.

Input Transient Voltage Protection

A built-in suppressor diode provides effective protection against input transients which may be caused for example by short-circuits across the input lines where the network inductance may cause high energy pulses.

Table 3: Built-in transient voltage suppressor

Type	Breakdown voltage $V_{BR\ nom}$ [V]	Peak power at 1 ms P_P [W]	Peak pulse current I_{PP} [A]
24 IMS 25	53	600	7.7
48 IMS 25	100	600	4.1

For very high energy transients as for example to achieve IEC/EN 61000-4-5 or ETR 283 (19 Pfl1) compliance (as per table: *Electromagnetic Immunity*) an external inductor and capacitor are required.

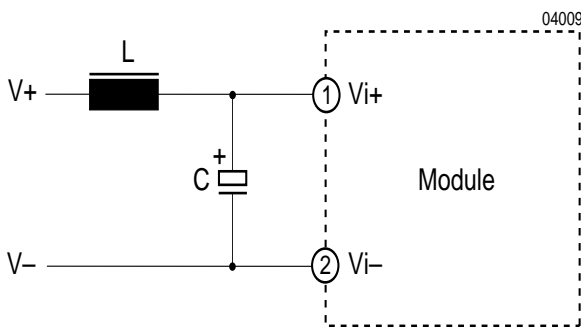


Fig. 3

Example for external circuitry to comply with IEC/EN 61000-4-5 or ETR 283 (19 Pfl1) (48 IMS 25 types).

Electrical Output Data

General conditions:

$T_A = 25^\circ\text{C}$, unless T_C is specified. Shut down pin left open (not connected). Trim input not connected.

Table 5a: Output data

Output		Conditions	2.5 V			3.3 V			5.1 V			Unit
Characteristics			min	typ	max	min	typ	max	min	typ	max	
U_{O1}	Output voltage	$U_{i\ nom}, I_o = 0.5 I_{o\ nom}$	2.47		2.53	3.26		3.34	5.05		5.15	V
$I_{o\ nom}$	Output current	$U_{i\ min} \dots U_{i\ max}$	0		6	0		6	0		5	A
I_{oL}	Current limit ¹	$U_{i\ min}$			9			9			9	
ΔU_o	Line/load regulation (combined)	$U_{i\ min} \dots U_{i\ max}$ $I_o = (0.01 \dots 1) I_{o\ nom}$			± 1			± 1			± 1	%
u_{o1}	Output voltage noise ² (B/W 20MHz)				100			100			120	mV _{pp}
$C_{o\ ext}$	Admissible capacitive load ³				2200			2200			2200	μF
$u_{o\ d}$	Dynamic load regulation	Voltage deviation			± 250			± 250			± 400	mV
t_d		Recovery time	$U_{i\ nom}$ $I_o \text{ nom} \times 1/2 I_o \text{ nom}$			5			5			2
α_{Uo}	Temperature coefficient $\Delta U_o / \Delta T_C$	$U_{i\ nom}, I_o \text{ nom}$ $T_C \text{ min} \dots T_C \text{ max}$			± 0.02			± 0.02			± 0.02	%/K
fs	Switching frequency	$U_{i\ nom}, I_o \text{ nom}$			approx 330			approx 330			approx 330	kHz

¹ The current limit is primary side controlled.

² Measured with $1\ \mu\text{F}$ ceramic capacitor across the o/p terminals

³ Measured with constant resistance load

Table 4: Components for external circuitry to comply with IEC/EN 61000-4-5, level 2 or ETR 283 (19 Pfl1) (48 IMS types).

Circuit Ref.	24 IMS 25	48 IMS 25
L	150 μH	
C	150 μF , 63 V, 85°C	100 μF , 100 V, 85°C

Reverse Polarity Protection at the Input

The built-in suppressor diode also provides for reverse polarity protection at the input by conducting current in the reverse direction. An external fuse is required to limit this current:

24 IMS 25: 5 A (F5A)

48 IMS 25: 3.15 A (F3.15A)

Table 5b: Output data

Output			12 V			15 V			Unit
Characteristics		Conditions	min	typ	max	min	typ	max	
U_{o1}	Output voltage	$U_{i\ nom}, I_o = 0.5 I_{o\ nom}$	11.88		12.12	14.85		15.15	V
$I_{o\ nom}$	Output current	$U_{i\ min} \dots U_{i\ max}$	0		2	0		1.6	A
I_{oL}	Current limit ¹	$U_{i\ min}$	3			2.4			
ΔU_o	Line/load regulation (combined)	$U_{i\ min} \dots U_{i\ max}$	± 1			± 1			%
u_{o1}	Output voltage noise ² (B/W 20MHz)	$I_o = (0.01 \dots 1) I_{o\ nom}$	150			180			mV _{pp}
$C_{o\ ext}$	Admissible capacitive load ³		650			430			μ F
$u_{o\ d}$	Dynamic load regulation	Voltage deviation	$U_{i\ nom}$			± 750			mV
t_d		Recovery time	$I_{o\ nom} \times^{1/2} I_{o\ nom}$			1			ms
α_{U_o}	Temperature coefficient $\Delta U_o / \Delta T_C$	$U_{i\ nom}, I_{o\ nom}$ $T_C\ min \dots T_C\ max$	± 0.02			± 0.02			%/K
fs	Switching frequency	$U_{i\ nom} \dots I_{o\ nom}$	approx 200			approx 200			kHz

¹ The current limit is primary side controlled.
² Measured with 1 μ F ceramic capacitor across the o/p terminals
³ Measured with constant resistance load

Thermal Considerations

If a converter, mounted on a PCB, is located in free, quasi-stationary air (convection cooling) at the indicated maximum ambient temperature $T_{A\ max}$ (see table: *Temperature specifications*) and is operated at its nominal input voltage and output power, the case temperature T_C measured at the *Measuring point of case temperature T_C* (see: *Mechanical Data*) will approach the indicated value $T_{C\ max}$ after the warm-up phase. However, the relationship between T_A and T_C depends heavily on the conditions of operation and integration into a system. The thermal conditions are influenced by input voltage, output current, airflow, temperature of surrounding components and surfaces and the properties of the printed circuit board. $T_{A\ max}$ is therefore only an indicative value and under practical operating conditions, the admissible ambient temperature T_A may be higher or lower than this value.

Caution: The case temperature T_C measured at the *Measuring point of case temperature T_C* (see: *Mechanical Data*) must under no circumstances exceed the specified maximum value. The installer must ensure that under all operating conditions T_C remains within the limits stated in the table: *Temperature specifications*.

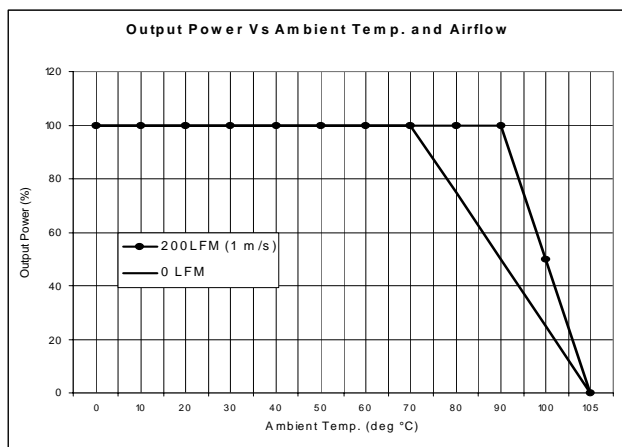


Fig. 4 Power derating for uncased (-Z) versions in airflow.

Overtemperature Protection

The converters are protected from possible overheating by means of an internal non latching temperature monitoring circuit. It shuts down the unit above the internal temperature limit and attempts to automatically restart in short periods. This feature prevents from excessive internal temperature excursion which could occur in heavy overload conditions.

Short Circuit Behaviour

The current limit characteristic shuts down the converter whenever a short circuit or an overload is applied to its output. It acts self-protecting and automatically recovers after removal of the overload condition (hiccup mode).

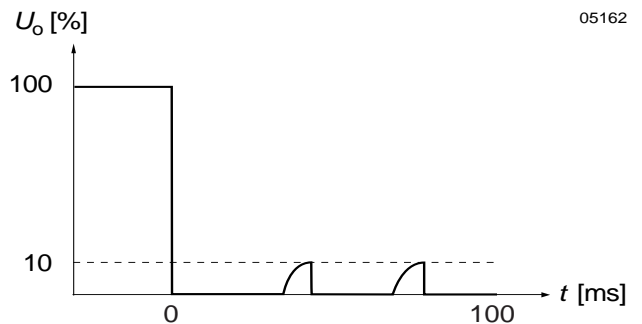


Fig. 5 Overload switch off (hiccup mode), typical values.

Auxiliary Functions

Shut Down Function

The outputs of the converters may be enabled or disabled by means of a logic signal (TTL, CMOS, etc.) applied to the shut down pin. If the shut down function is not required then pin should be left open-circuit.

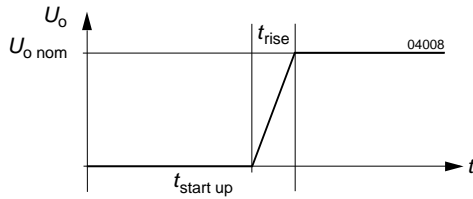


Fig. 7 Converter start-up and rise time (applying $U_{i\ nom}$).

Converter operating: 2.0...5.5 V
 Converter shut down: -10...0.7 V

The shut down pin can also be used as a programmable undervoltage lockout. The undervoltage lockout values for the 24 IMS and 48 IMS series are 13 and 31 V respectively with a 0.5 V hysteresis window. These factory settings can be trimmed up by means of an external resistor connected between the \overline{SD} pin and V_{i-} pin.

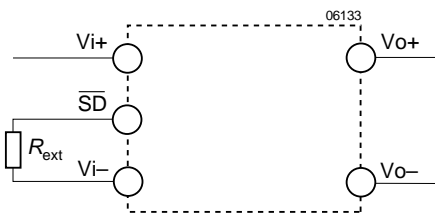


Fig. 8 Shut down (\overline{SD}) and undervoltage lockout (PUL) function.

Table 6: Typical values for undervoltage lockout (PUL) settings.

24 IMS 25		48 IMS 25	
R_{ext} [k Ω]	$U_{i\ min}$ [V]	R_{ext} [k Ω]	$U_{i\ min}$ [V]
	13.5		31
250	15	50	34
100	16	29	36
60	17	20	38
30	18	15	40

Synchronisation

The IMS 25 features a bi-directional synchronisation function to synchronise several IMS 25 units operated in parallel connection. Consult factory if this option is required, for full application details.

Adjustable Output Voltage

As a standard feature, the IMS 25 units offer adjustable output voltage by using the secondary referenced Trim input. If the Trim input is left open-circuit the output voltage is set to $U_{o\ nom}$. Adjustment of the output voltage is possible by means of an external resistor R_{ext} connected between the Trim pin and the either V_{o+} or V_{o-} .

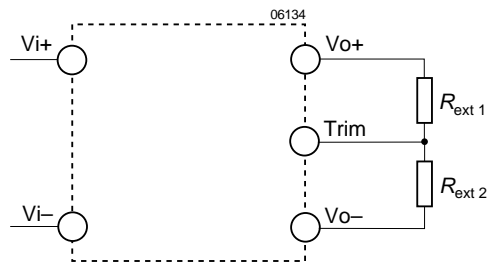


Fig. 9 Output voltage Trim.

To trim down U_{onom} :-

$$R_{ext\ 1} = [A * (U_o - D) / (U_{onom} - U_o)] - B$$

To trim up U_{onom} :-

$$R_{ext\ 2} = (C / (U_o - U_{onom})) - B$$

Table 7: Constant values to adjust U_o from 90...110% U_{onom} ; typical values ($U_{i\ nom}$, $I_o = 0.5 I_{onom}$)

$U_{o\ nom}$	A	B	C	D
2.5	2200	1000	2728	1.24
3.3	1800	1800	2229	1.24
5.1	1000	430	1240	1.24
12	5100	5100	12750	2.5
15	6200	10000	15500	2.5

Electromagnetic Compatibility (EMC)

A suppressor diode together with an input filter form an effective protection against high input transient voltages

which typically occur in many installations, but especially in battery driven mobile applications.

Electromagnetic Immunity

Table 8: Immunity type tests

Phenomenon	Standard ¹	Class Level	Coupling mode ²	Value applied	Waveform	Source Imped.	Test procedure	In oper.	Per-form. ³
Electrostatic discharge to case	IEC/EN 61000-4-2	2	contact discharge	4000 V _p	1/50 ns	330 Ω	10 positive and 10 negative discharges	yes	B
		3	air discharge	8000 V _p					
Electromagnetic field	IEC/EN 61000-4-3	2	antenna	3 V/m	AM 80% 1 kHz		26...1000 MHz	yes	A
	ENV 50204				PM, 50% duty cycle, 200 Hz resp. frequ.		900 MHz		
Electrical fast transient/burst	IEC/EN 61000-4-4	3	direct +i/-i	2000 V _p	bursts of 5/50 ns 5 kHz rep. rate transients with 15 ms burst duration and a 300 ms period	50 Ω	1 min positive 1 min negative transients per coupling mode	yes	A
Surge	IEC/EN 61000-4-5 ⁵	2	+i/-i	1000 V _p	1.2/50 μs	2 Ω	5 pos. and 5 neg. impulses per coupling mode	yes	B
Conducted disturbances	IEC/EN 61000-4-6	2	+i/-i	3 V _{rms} (130 dBμV)	AM modulated 80%, 1 kHz	50 Ω	0.15...80 MHz 150 Ω	yes	A
Transient	ETR 283 (19 PFI 1) ⁴		+i/-i	150 V _p	0.1/0.3 ms	limited to <100 A	3 positive	yes	B

¹ Related and previous standards are referenced in: *Technical Information: Standards*.

² i = input, o = output.

³ A = normal operation, no deviation from specification, B = temporary deviation from specs. possible.

⁴ For 48 IMS 25 types (additional external components required). Not applicable for 24 IMS 25 types.

⁵ External components required.

EMC Specifications

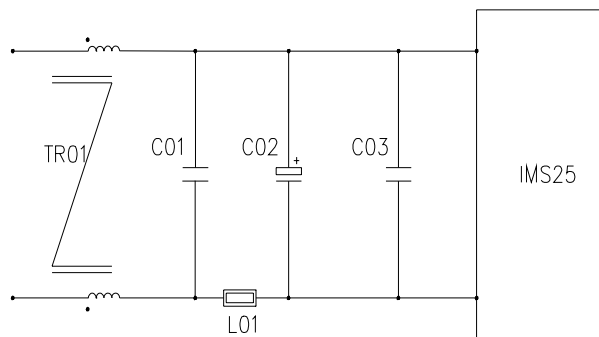


Fig. 10
Circuit required to meet level B of CISPR 22/EN 55022, measured at $U_{i\text{ nom}}$ and $I_{o\text{ nom}}$.

Reference Designator	Description	Part Number	Vendor
TR01	80μH common mode choke	PD0034	Pulse Engineering
C01	1 μF ceramic capacitor	18124C105KAT4A	AVX
L01	47μH inductor	DS5022P-473	Coilcraft
C02	47μF electrolytic capacitor	B41588-D9476-T	Siemens
C03	130 nF ceramic capacitor	1206B134M101NT	Novacap

Immunity to Environmental Conditions

Table 9: Environmental testing

Test method		Standard	Test conditions		Status
Ca	Damp heat steady state	IEC/DIN IEC 60068-2-3 MIL-STD-810D section 507.2	Temperature: Relative humidity: Duration:	40 ±2 °C 93 +2/-3 % 56 days	Unit not operating
Ea	Shock (half-sinusoidal)	IEC/EN/DIN EN 60068-2-27 MIL-STD-810D section 516.3	Acceleration amplitude: Bump duration: Number of bumps:	50 g _n = 490 m/s ² 11 ms 18 (3 each direction)	Unit operating
Eb	Bump (half-sinusoidal)	IEC/EN/DIN EN 60068-2-29 MIL-STD-810D section 516.3	Acceleration amplitude: Bump duration: Number of bumps:	25 g _n = 245 m/s ² 11 ms 6000 (1000 each direction)	Unit operating
Fc	Vibration (sinusoidal)	IEC/EN/DIN EN 60068-2-6	Acceleration amplitude: Frequency (1 Oct/min): Test duration:	0.35 mm (10...60 Hz) 5 g _n = 49 m/s ² (60...2000 Hz) 10...2000 Hz 7.5 h (2.5 h each axis)	Unit operating
Kb	Salt mist, cyclic (sodium chloride NaCl solution)	IEC/EN/DIN IEC 60068-2-52	Concentration: Duration: Storage: Storage duration: Number of cycles:	5% (30°C) 2 h per cycle 40°C, 93% rel. humidity 22 h per cycle 3	Unit not operating

Table 10: Temperature specifications, valid for air pressure of 800...1200 hPa (800...1200 mbar)

Temperature		Standard -9		Unit
Characteristics	Conditions	min	max	
T _A	Ambient temperature	Operating, no airflow	-40	°C
T _C	Case temperature		-40	
T _S	Storage temperature	Non operational	-55	105

Table 11: MTBF

Values at specified case temperature	Type	Ground benign 40°C	Ground fixed		Ground mobile 50°C
			40°C	70°C	
MTBF	48 IMS 25-05-9G	740'000	247'000	126'800	200'000
MIL-HDBK 217F	48 IMS 25-12-9	830'000	301'000	159'000	247'500

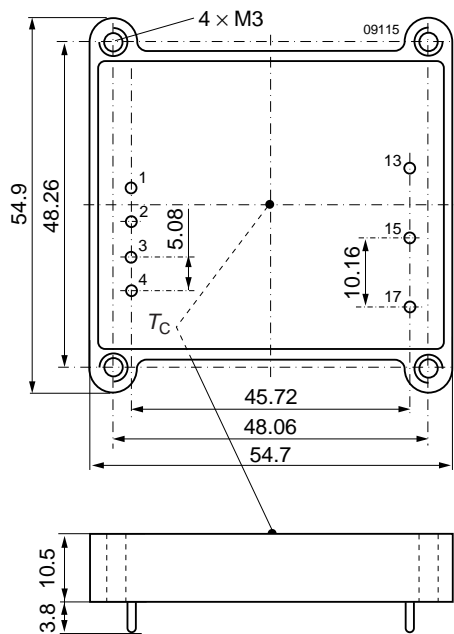
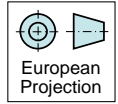
Mechanical DataDimensions in mm. Tolerances ± 0.3 mm unless otherwise indicated.

Fig. 11
Case IMS 25
Weight: 42 g

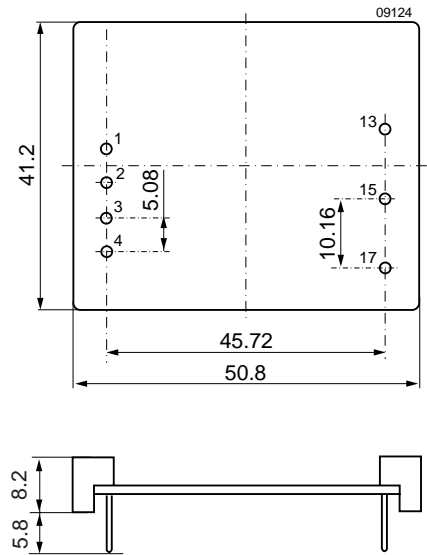


Fig. 12
Case IMS 25, open frame (option Z)
Weight: 26 g

Safety and Installation Instructions

Installation Instruction

Installation of the DC-DC converters must strictly follow the national safety regulations in compliance with the enclosure, mounting, creepage, clearance, casualty, markings and segregation requirements of the end-use application.

Connection to the system shall be made via a printed circuit board with hole diameters of 1.4 mm \pm 0.1 mm for the pins.

The units should be connected to a secondary circuit.

Check for hazardous voltages before altering any connections.

Do not open the module.

Ensure that a unit failure (e.g. by an internal short-circuit) does not result in a hazardous conditions. See also: *Safety of operator accessible output circuit.*

Input Fuse

To prevent excessive current flowing through the input supply line in case of a short-circuit across the converter input an external fuse should be installed in a non earthed input supply line. We recommend a fast acting fuse F5A for 24 IMS 25 types and F3.15A for 48 IMS 25 types.

Standards and approvals

All DC-DC converters are pending to be UL recognized according to UL 1950, UL recognized for Canada to CAN/CSA C22.2 No. 950-95 and LGA approved to IEC/EN 60950 standards.

The units have been evaluated for:

- Building in
- Basic insulation input to output, based on their maximum input voltage
- The use in a pollution degree 2 environment
- Connecting the input to a secondary circuit which is subject to a maximum transient rating of 1500 V

After approvals the DC-DC converters are subject to manufacturing surveillance in accordance with the above mentioned UL, CSA, EN and ISO 9001 standards.

Isolation

The electric strength test is performed as factory test in accordance with IEC/EN 60950 and UL 1950 and should not be repeated in the field. Power-One will not honour any guarantee claims resulting from electric strength field tests.

Table 12: Electric strength test voltages

Characteristic	Input to output	Unit
Electric strength test voltage 1 s	1.1	kV _{rms}
	1.5	kV DC
Coupling capacitance	2.2	nF
Insulation resistance at 500 V DC	>100	M Ω
Partial discharge extinction voltage	Consult factory	kV

Table 13: Pin allocation

Pin No.	Single output	Single output option i
1	Vi+	Vi+
2	Vi-	Vi-
3	W	W
4	\overline{SD}	i
13	Vo+	Vo+
15	Vo-	Vo-
17	Trim	Trim

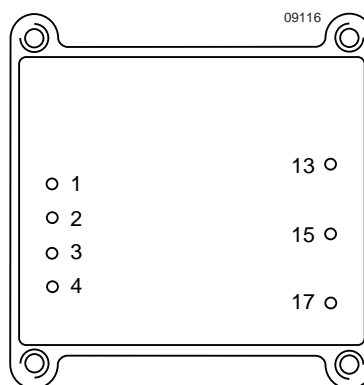


Fig. 13
Pin allocation

Protection Degree

The protection degree of the DC-DC converters is IP 40.

Cleaning Agents

In order to avoid possible damage, any penetration of cleaning fluids should be prevented, since the power supplies are not hermetically sealed (use option Z).

Safety of Operator Accessible Output Circuit

If the output circuit of a DC-DC converter is operator accessible, it shall be an SELV circuit according to IEC/EN 60950 related safety standards

The following table shows some possible installation configurations, compliance with which causes the output circuit of the DC-DC converter to be an SELV circuit according to IEC/EN 60950 up to a configured output voltage of 42 V.

However, it is the sole responsibility of the installer to ensure the compliance with the relevant and applicable safety regulations. More information is given in: *Technical Information: Safety.*

Table 14: Insulation concept leading to an SELV output circuit

Conditions	Front end			DC-DC converter	Result	
Supply voltage	Minimum required grade of isolation, to be provided by the AC-DC front end, including mains supplied battery charger	Maximum DC output voltage from the front end ¹	Minimum required safety status of the front end output circuit	Measures to achieve the specified safety status of the output circuit	Safety status of the DC-DC converter output circuit	
Mains -250 V AC	Basic	-60 V	Earthed SELV circuit ²	Operational insulation (provided by the DC-DC converter)	SELV circuit	
			ELV circuit	Input fuse ³ output suppressor diode(s) ⁴ , and earthed output circuit(s) ²	Earthed SELV circuit	
	Double or reinforced	>60 V	Hazardous voltage secondary circuit			
			SELV circuit	Operational insulation (provided by the DC-DC converter)	SELV circuit	
			TNV-2 circuit	Supplementary insulation, based on the maximum input voltage (provided by the DC-DC converter)		
			Double or reinforced insulated unearthed hazardous voltage secondary circuit ⁵			

¹ The front end output voltage should match the specified input voltage range of the DC-DC converter.
² The earth connection has to be provided by the installer according to the relevant safety standard, e.g. IEC/EN 60950.
³ The installer shall provide an approved fuse (type with the lowest rating suitable for the application) in a non-earthed input line directly at the input of the DC-DC converter (see fig.: *Schematic safety concept*). For UL's purpose, the fuse needs to be UL-listed. See also: *Input Fuse*.
⁴ Each suppressor diode should be dimensioned in such a way, that in the case of an insulation fault the diode is able to limit the output voltage to SELV (<60 V) until the input fuse blows (see fig.: *Schematic safety concept*).
⁵ Has to be insulated from earth by basic insulation according to the relevant safety standard, based on the maximum output voltage from the front end.

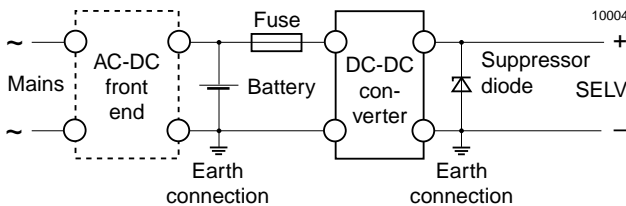


Fig. 14 Schematic safety concept. Use fuse, suppressor diode and earth connection as per table: Safety concept leading to an SELV output circuit.

Description of Option

Option i Inhibit

Excludes shut down

The output(s) of the converter may be enabled or disabled by means of a logic signal (TTL, CMOS, etc.) applied to the inhibit pin. No output voltage overshoot will occur when the unit is turned on. If the inhibit function is not required the inhibit pin should be connected to Vi- to enable the output (active low logic, fail safe).

Converter operating: -10 V...0.8 V
 Converter inhibited or inhibit pin left open circuit 2.4...5 V

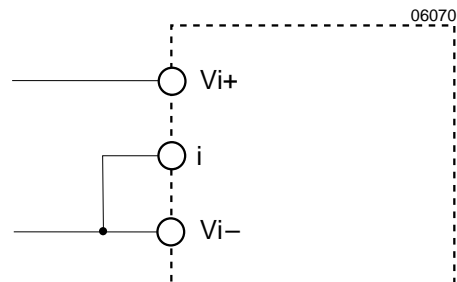


Fig. 15 If the inhibit is not used the inhibit pin should be connected to Vi-