





SMT POWER INDUCTORS

Shielded Toroid Series - Ros1/Ros2 Series



TWO PACKAGE SIZES:

-  **Height:** 3.2mm and 5.3mm Max
-  **Footprint:** 8.1mm x 5.3mm and 14.0mm x 10.2mm
-  **Current Rating:** up to 5A
-  **Inductance Range:** .51 μ H to 357 μ H

Electrical Specifications @ 25°C — Operating Temperature -40°C to +130°C

Pulse Part Number	Inductance @ I _{rated} (μ H Min)	I _{rated} (A)	DCR (m Ω)		Inductance @ 0A _{DC} (μ H +/- 15%)	Reference ET (V \cdot μ sec)	Trise Factor (K0)	Coreloss Factor (K1)	ET Factor (K2)
			TYP	MAX					
Ros 1 Series									
P0430	0.51	2.00	14	16.1	.7	.8	1.45	1.27E-11	476.2
P0431	0.76	1.90	18	20.7	1.1	.8	1.45	1.27E-11	370.4
P0432	0.85	1.50	18	20.7	1.1	1.2	1.45	1.27E-11	370.4
P0433	1.44	1.20	28	32.2	1.9	1.8	1.45	1.27E-11	277.8
P0434	1.87	1.20	34	39.1	2.6	1.8	1.45	1.27E-11	238.1
P0435	2.72	1.00	40	46	3.9	2.3	1.45	1.27E-11	196.1
P0436	4.33	0.70	73	84	6.0	3.1	1.45	1.27E-11	158.7
P0437	5.35	0.60	100	115	7.1	3.3	1.45	1.27E-11	144.9
P0438	8.84	0.50	140	161	12.2	4.4	1.45	1.27E-11	111.1
P0439	10.79	0.45	155	178	14.7	5.0	1.45	1.27E-11	101.0
P0440	17.59	0.34	250	288	23.8	6.5	1.45	1.27E-11	79.4
P0441	25.50	0.29	280	322	33.8	8.4	1.45	1.27E-11	66.7
P0442	35.80	0.24	440	506	49	9.8	1.45	1.27E-11	55.6
P0443	52.70	0.20	650	747	72	12	1.45	1.27E-11	45.7
P0444	79	0.17	1050	1208	110	14	1.45	1.27E-11	37.0
P0445	88	0.16	1065	1225	122	15	1.45	1.27E-11	35.1
P0446	127	0.14	1600	1840	179	18	1.45	1.27E-11	29.0
Ros 2 Series									
P0450	0.51	5.00	7.6	8.7	.65	3	.508	8.87E-11	181.8
P0451	0.67	5.00	8.7	10	.86	3.1	.508	8.87E-11	151.5
P0452	1.09	5.00	11.4	13.1	1.5	.5	.508	8.87E-11	113.6
P0453	1.53	5.00	13.0	15	2.3	1.0	.508	8.87E-11	90.9
P0454	1.78	3.00	15.0	17.3	2.3	7.5	.508	8.87E-11	90.9
P0455	3.74	2.50	23.0	26.5	5.1	10.5	.508	8.87E-11	60.6
P0456	4.76	2.00	26.1	30	6.3	13	.508	8.87E-11	56.8
P0457	5.61	1.80	33.0	38	7.5	14	.508	8.87E-11	50.5
P0458	9.09	1.50	70.4	81	13.2	15	.508	8.87E-11	39.5
P0459	11.47	1.30	60.0	69	15.5	21	.508	8.87E-11	35.0
P0460	22.95	1.00	90.4	104	34	31	.508	8.87E-11	24.6
P0461	39.10	0.90	123.5	142	57.2	39	.508	8.87E-11	18.9
P0462	40.80	0.80	240.0	276	62.5	35	.508	8.87E-11	18.2
P0463	69.70	0.60	245.2	282	100	55	.508	8.87E-11	14.0
P0464	76.50	0.50	305.2	351	103	54	.508	8.87E-11	14.2
P0465	137	0.40	480.9	553	180	78	.508	8.87E-11	10.0
P0466	182	0.35	681.7	784	254	87	.508	8.87E-11	8.7
P0467	272	0.30	1030.4	1185	422.5	105	.508	8.87E-11	7.0
P0468	357	0.25	1200.0	1380	500	130	.508	8.87E-11	6.1

SMT POWER INDUCTORS

Shielded Toroid Series - Ros1/Ros2 Series



Notes:

1. Temperature rise is 55°C in typical buck or boost circuits with the rated I_{bc} current and reference ET applied to the inductor.
2. Total loss in the inductor is 80 mW (ROS 1) and 280 mW (ROS 2) for 55°C temperature rise above ambient.
3. To estimate temperature rise in a given application, you must determine the total losses (copper losses + core losses) and apply the following formula:
Temp Rise (C) = (Total Losses (mW))^{0.833} * KO (from table)
4. To determine copper losses, calculate:
Copper Loss (mW) = I_{bc}² * DCR
5. For core loss in mWatts, using frequency f (in Hz) and operating flux density B (in Gauss), calculate:
Core Loss (mW) = k₂ * f^{1.26} * B^{2.11}
6. For flux density (B), calculate ET (V-μsec) for the application, and multiply by ET₁₀ factor from the table.

Mechanical

Schematic

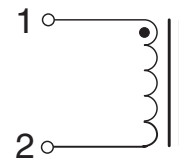
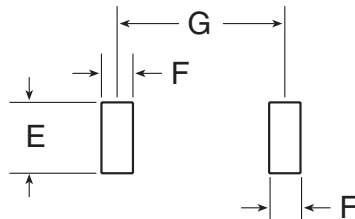
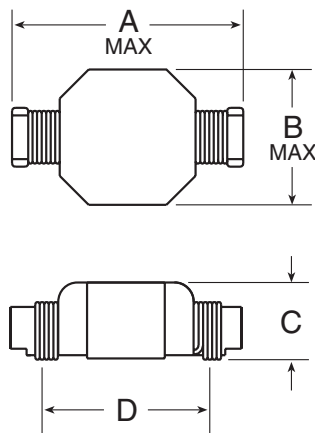

Suggested Pad Layout

	ROS 1	ROS 2
Weight	0.29 grams	1.1 grams
Tape & Reel	2000/reel	600/reel
Dimensions:	Inches	mm
	mm	
Unless otherwise specified, all tolerances are ± $\frac{.010}{0.25}$		

PKG	A	B	C	D	E	F	G
ROS 1	.335 8,51	.225 5,72	.125 3,18	.250 6,35	.100 2,54	.050 1,27	.250 6,35
ROS 2	.545 13,84	.390 9,91	.215 5,46	.440 11,18	.120 3,05	.065 1,65	.440 11,18

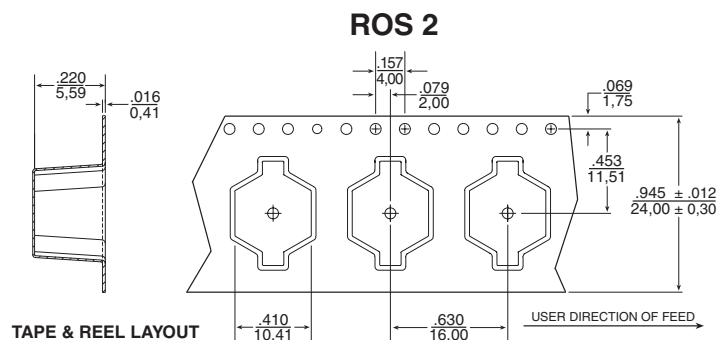
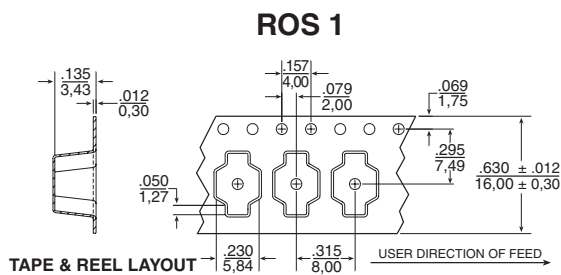

For More Information:

Pulse Worldwide Headquarters
12220 World Trade Drive
San Diego, CA 92128
U.S.A.
www.pulseeng.com
TEL: 858 674 8100
FAX: 858 674 8262

Pulse Northern Europe
3 Huxley Road
Surrey Research Park
Guildford, Surrey GU2 5RE
United Kingdom
TEL: 44 1483 401700
FAX: 44 1483 401701

Pulse Southern Europe
Zone Industrielle
F-39270
Orgelet
France
TEL: 33 3 84 35 04 04
FAX: 33 3 84 25 46 41

Pulse China Headquarters
No. 1
Industrial District
Changan, Dongguan
China
TEL: 86 769 5538070
FAX: 86 769 5538870

Pulse North China
Room 1002
No. 819
Nanjing West Rd
Shanghai
China
TEL: 86 21 32181071
FAX: 86 21 32181396

Pulse South Asia
150 Kampong Ampat
#07-01/02
KA Centre
Singapore 368324
TEL: 65 6287 8998
FAX: 65 6280 0080

Pulse North Asia
3F-4, No. 81, Sec. 1
Hsin Tai Wu Road
Hsi-Chih
Taipei Hsien
Taiwan
TEL: 886 2 26980228
FAX: 886 2 26980948

Performance warranty of products offered on this data sheet is limited to the parameters specified. Data is subject to change without notice. Other brand and product names mentioned herein may be trademarks or registered trademarks of their respective owners.
© Copyright, 2005. Pulse Engineering, Inc. All rights reserved.