

**DESIGNED & DIMENSIONED  
IN MILLIMETERS  
(INCHES FOR REFERENCE ONLY)**

DO NOT  
SCALE FROM  
THIS PRINT

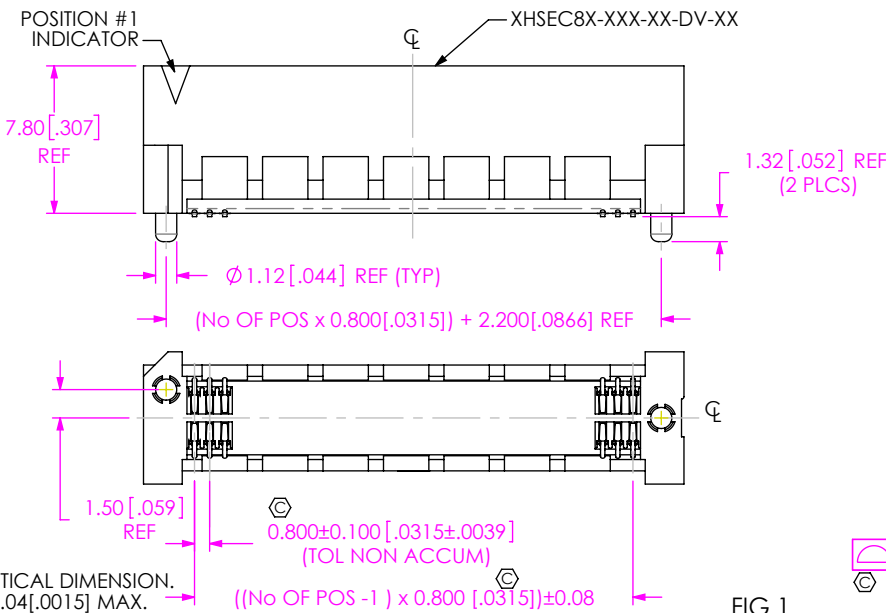
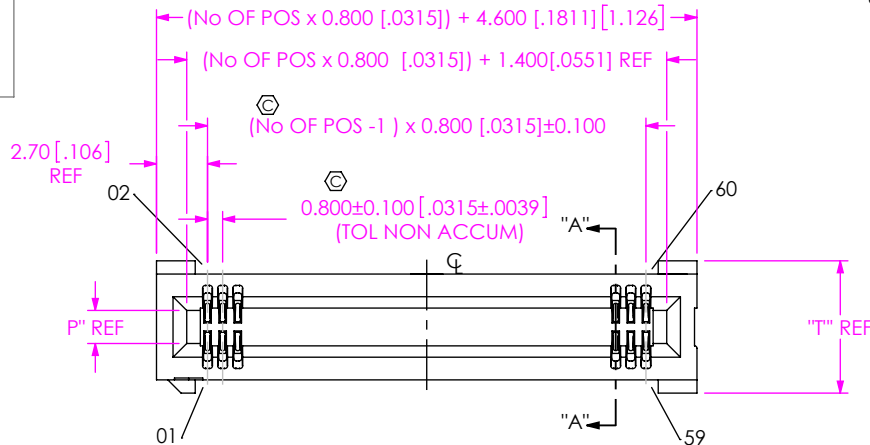

**FIG 1**  
FOR POSITIONS -10, -20 & -30  
HSEC8-130-01-XX-DV-A SHOWN  
(SOME FEATURES NOT SHOWN FOR CLARITY)

(SEE NOTE 12)

**HSEC8-1XXX-XX-XX-DV-X-XX-X-XX**

**No OF POSITIONS (PER ROW)**  
-10, -20, -30 (SEE FIG 1)  
■ -09, -13, -25, -37, -49, -40, -50, -60, -70,  
-80, -90, -100 (SEE FIG 2, SHT 2)

**CARD THICKNESS**  
(SEE TABLE 9, SHT 3)  
-01: 1.57 [.062] CARD  
-03: 2.36 [.093] CARD  
(10-100 POS, MULTIPLES OF 10 ONLY)  
(USE RHSEC8-XXX-03-DV-XX)  
(SEE NOTE 7 & 10)

**PLATING SPECIFICATION**  
-SM: 30µ" SELECTIVE GOLD IN CONTACT  
AREA, MATTE TIN ON TAIL  
-H: 30µ" HEAVY GOLD IN CONTACT  
AREA, 3µ" GOLD TAIL  
-S: 30µ" SELECTIVE GOLD IN CONTACT  
AREA, MATTE TIN ON TAIL  
-L: 10µ" LIGHT SELECTIVE GOLD IN  
CONTACT AREA, MATTE TIN ON TAIL

**ROW SPECIFICATION**  
-DV: DOUBLE VERTICAL

**OPTION 1**  
(LEAVE BLANK FOR NO ALIGNMENT PIN,  
USE XHSEC8-XXX-01-DV-LC, NOT  
AVAILABLE FOR CARD THICKNESS -03  
SEE FIG 10, SHT 3)  
-A: ALIGNMENT PIN  
(USE XHSEC8X-XXX-XX-DV-A)

**PACKAGING OPTION**  
-TR: TAPE & REEL (SEE NOTES 17, 18 & 19)  
(09 THRU 70 POS ONLY)  
-FR: FULL REEL QTY. TAPE & REEL  
(SEE NOTES 17, 18 & 19)  
(09 THRU 70 POS ONLY)  
(LEAVE BLANK FOR TRAY)

**PICK AND PLACE PAD**  
-K: POLYIMIDE FILM PAD (SEE SHT 2, FIG 3)

**OPTION 2**

\*\* -PE: PASS THROUGH (SHT 7, FIG 7)  
(10, 13, & 20 POS ONLY)  
(-A OPTION ONLY)  
(NOT AVAILABLE WITH ANY OTHER OPTION  
2, EXCEPT -K AND/OR -TR & -FR)  
\*\* -BL: BOARD LOCK (SHT 5, FIG 5) (SEE NOTE 11)  
(-A OPTION ONLY)  
\*\* -GR: GUIDE RAILS (SHT 6, FIG 6)  
(10-60 POS, MULTIPLES OF 10 ONLY)  
(SEE NOTE 11) (-TR & -FR PACKAGING ONLY)  
-WT: WELD TAB (SHT 7, FIG 8)  
(-A OPTION ONLY)  
\*\* -L: LATCHING (SHT 4, FIG 4)  
(13, 25, 37, & 49 POS ONLY) (SEE NOTE 11)  
(-A OPTION ONLY)  
\*\* -L2: ECDP LATCHING (SHT 8, FIG 9)  
(09, 13, 25, & 49 POS ONLY) (SEE NOTE 11)  
(-A OPTION ONLY)

\*\* = AVAILABLE ONLY WITH -01 CARD THICKNESS  
■ = AVAILABLE ONLY WITH END OPTIONS -BL, -WT, & -L2

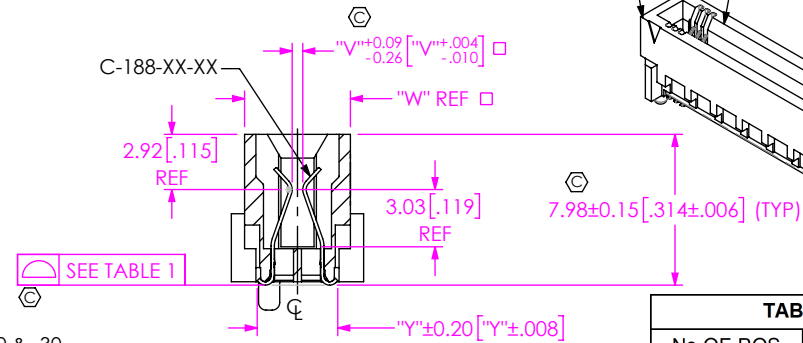

**SECTION "A"-"A"**

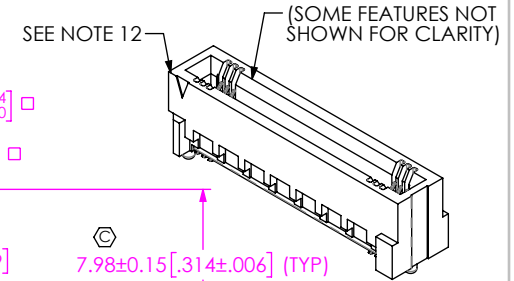

TABLE 1	
No OF POS	COPLANARITY
-10 THRU -60	0.102 [.0040]
-70 THRU -100	0.127 [.0050]

- NOTES:
1. © REPRESENTS A CRITICAL DIMENSION.
  2. BURR ALLOWANCE: 0.04 [.0015] MAX.
  3. MINIMUM PUSHOUT FORCE: 2.2 NEWTONS.
  4. ALL TAIL TO TAIL DIMENSIONS MEASURED TIP TO TIP.
  5. ASSEMBLIES TO BE PACKAGED IN TRAYS, UNLESS -TR/-FR IS SPECIFIED.
  6. NOTE DELETED.
  7. MATING EDGE CARD THICKNESS TOLERANCE TO BE ± 0.15 [.006] OF NOMINAL.
  8. NOTE DELETED.
  9. NOTE DELETED.
  10. MATING CARD MUST HAVE LEAD-IN. SEE SAMTEC FOOTPRINT FOR SPECIFICATIONS.
  11. L, L2, & BL IS NOT APPLICABLE FOR GUIDE RAIL TYPE USE. GR NOT APPLICABLE FOR L, L2, OR BL TYPE USE.
  12. CORNER VOIDS AT VENDOR DISCRETION, AND MAY OR MAY NOT BE PRESENT.
  13. MEASURE DIMENSION WITH LATCH IN LOCKED, PERPENDICULAR POSITION.
  14. VOID WIDTH, LOCATION, AND FREQUENCY TO BE AT VENDORS DISCRETION.
  15. NOTE DELETED.
  16. NOTE DELETED.
  17. ORDERS WILL BE PACKAGED ACCORDING TO THE SAMTEC PACKAGING EFFICIENCY STANDARDS (SPES) FOUND ON WWW.SAMTEC.COM
  18. ATTACH LABEL TO EACH REEL
  19. TRAYS ARE STANDARD PACKAGING.

UNLESS OTHERWISE SPECIFIED,  
DIMENSIONS ARE IN MILLIMETERS.

TOLERANCES ARE:  
DECIMALS ANGLES  
.X: ± .3 [.01]  
.XX: ± .13 [.005]  
.XXX: ± .051 [.0020]

c:\enterprise\vaull\DWG\MISC\MKTG\HSEC8-1XXX-XX-XX-DV-X-XX-X-XX-MKT.SLDDR

**PROPRIETARY NOTE**  
THIS DOCUMENT CONTAINS CONFIDENTIAL AND  
PROPRIETARY INFORMATION AND ALL DESIGN,  
MANUFACTURING, REPRODUCTION, USE, PATENT RIGHTS  
AND SALES RIGHTS ARE EXPRESSLY RESERVED BY SAMTEC,  
INC. THIS DOCUMENT SHALL NOT BE DISCLOSED, IN WHOLE  
OR PART, TO ANY UNAUTHORIZED PERSON OR ENTITY NOR  
REPRODUCED, TRANSFERRED OR INCORPORATED IN ANY  
OTHER PROJECT IN ANY MANNER WITHOUT THE EXPRESS  
WRITTEN CONSENT OF SAMTEC, INC.

**MATERIAL:** DO NOT SCALE DRAWING SHEET SCALE: 2.5:1  
**INSULATOR:** LCP  
**COLOR:** -01 CARD THICKNESS BLACK,  
-03 CARD THICKNESS NATURAL  
**CONTACT:** BeCu

**DESCRIPTION:**  
0.8mm HIGH SPEED EDGE CARD ASSEMBLY  
**DWG. NO.**  
HSEC8-1XXX-XX-XX-DV-X-XX-X-XX  
**BY:** BRATCHER 01/24/03 **SHEET 1 OF 8**



520 PARK EAST BLVD, NEW ALBANY, IN 47150  
PHONE: 812-944-6733 FAX: 812-948-5047  
e-Mail: info@SAMTEC.com code: 55322

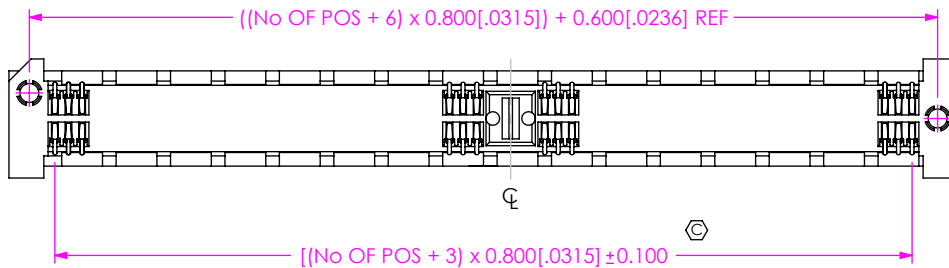
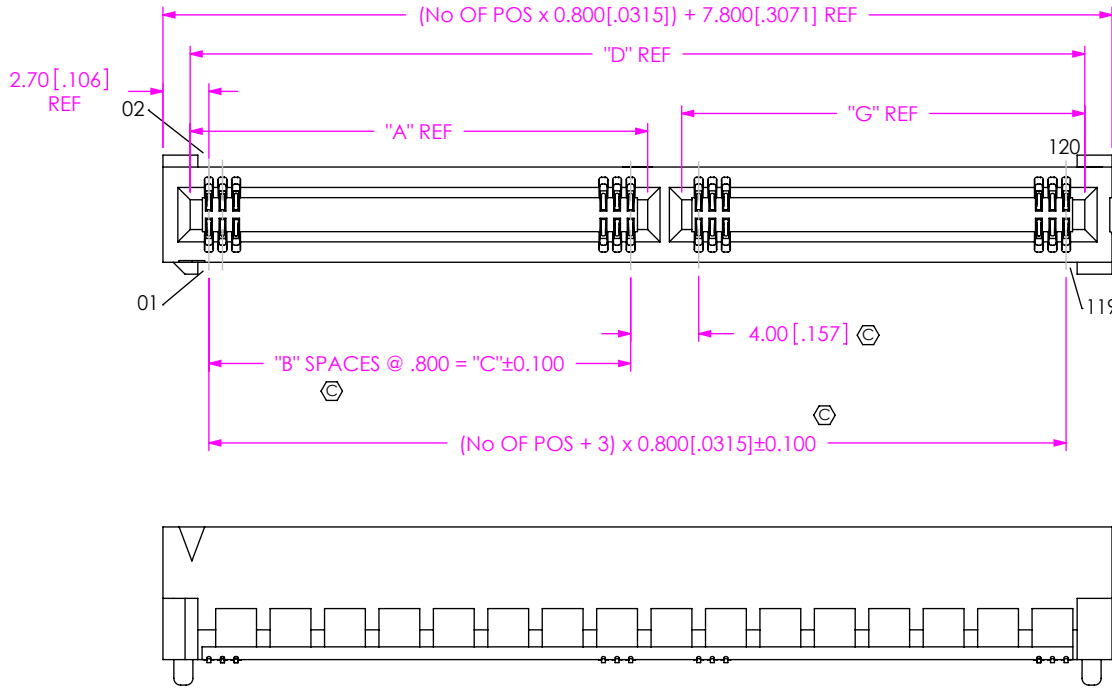

No OF POS	"A"	"B"	"C"	"D"	"G"
■**-09	4.50 [.177]	3	2.400 [.0945]	11.80 [.465]	5.30 [.209]
**13	6.10 [.240]	5	4.000 [.1575]	15.00 [.591]	6.90 [.272]
**25	6.10 [.240]	5	4.000 [.1575]	24.60 [.969]	16.50 [.650]
**37	18.10 [.713]	20	16.000 [.6299]	34.20 [1.346]	14.10 [.555]
-40	18.90 [.744]	21	16.800 [.6614]	36.60 [1.441]	15.70 [.618]
**49	22.90 [.902]	26	20.800 [.8189]	43.80 [1.724]	18.90 [.744]
-50	22.90 [.902]	26	20.800 [.8189]	44.60 [1.756]	19.70 [.776]
-60	26.90 [1.059]	31	24.800 [.9764]	52.60 [2.071]	23.70 [.933]
-70	26.90 [1.059]	31	24.800 [.9764]	60.60 [2.386]	31.70 [1.248]
-80	26.90 [1.059]	31	24.800 [.9764]	68.60 [2.701]	39.70 [1.563]
-90	26.90 [1.059]	31	24.800 [.9764]	76.60 [3.016]	47.70 [1.878]
-100	26.90 [1.059]	31	24.800 [.9764]	84.60 [3.331]	55.70 [2.193]

FIG 2  
FOR POSITIONS ■\*\*-09, \*\*13, \*\*25, \*\*37,  
-40, \*\*49, -50, -60, -70, -80, -90, -100  
HSEC8-160-01-XX-DV-A SHOWN  
(DIFFERENT AS SHOWN, OTHERWISE SAME AS FIG 1)  
(SOME FEATURES NOT SHOWN FOR CLARITY)

(\*\* = AVAILABLE ONLY WITH  
-01 CARD THICKNESS)

\*\* = AVAILABLE ONLY WITH -01 CARD THICKNESS  
■ = AVAILABLE ONLY WITH END OPTIONS -BL, -WT & -L2

FIG 3  
-K OPTION  
(SOME FEATURES NOT SHOWN FOR CLARITY)

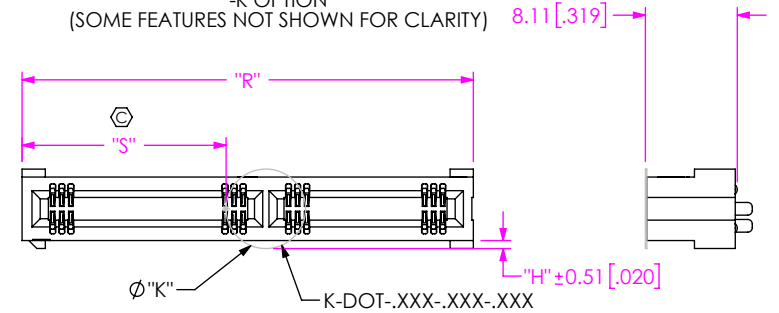

OPTION 2	No OF POS	"R"	"S"
NONE	-10 THRU -30	(No OF POS x 0.800[.0315]) + 4.600[.1811] REF	((("R" - "K") / 2) + /-0.51 [.020])
	-13, -25, -37, -40 THRU -100	(No OF POS x 0.800[.0315]) + 7.800[.3071] REF	
-WT	-10 THRU -30	(No OF POS x 0.800[.0315]) + 9.200[.3622] REF	((("R" - "K") / 2) + /-0.51 [.020])
	-09, -13, -25, -37, -40 THRU -100	(No OF POS x 0.800[.0315]) + 12.400[.4882] REF	
**-L	-13, -25, -37, & -49	(No OF POS x 0.800[.0315]) + 18.400[.7244] REF	((("R" - "K") / 2) + /-0.51 [.020])
	-10 THRU -30	(No OF POS x 0.800[.0315]) + 15.850[.6240] REF	
**-BL	-09, -13, -25, -37, -40 THRU -100	(No OF POS x 0.800[.0315]) + 19.050[.7500] REF	((("R" - "K") / 2) + /-0.51 [.020])
	-10, -13, & -20	(No OF POS x 0.800[.0315]) + 7.000 [.2756] REF	
**-PE	-10, -20, -30	(No OF POS x 0.800[.0315]) + 4.600[.1811] REF	((("R" - "K") / 2) + /-0.51 [.020])
	-40, -50, -60	(No OF POS x 0.800[.0315]) + 7.800[.3071] REF	
**L2	-09, -13, -25, -49	(No OF POS x 0.800[.0315]) + 13.660[.5378] REF	

\*\* = AVAILABLE ONLY WITH -01 CARD THICKNESS

CARD THICKNESS	K-DOT-.XXX-.XXX-.XXX	"K"	"U"	"H"
-01	K-DOT-.276-.375-.005	7.01 [.276]	2.61 [.103]	0.705 [.0278]
-03	K-DOT-.246-.375-.005	6.25 [.246]	3.40 [.134]	0.070 [.0027]

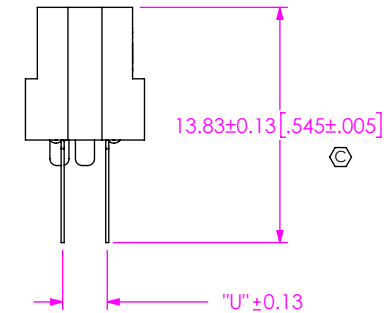

IN-PROCESS

PROPRIETARY NOTE  
THIS DOCUMENT CONTAINS CONFIDENTIAL AND PROPRIETARY INFORMATION AND ALL DESIGN, MANUFACTURING, REPRODUCTION, USE, PATENT RIGHTS AND SALES RIGHTS ARE EXPRESSLY RESERVED BY SAMTEC, INC. THIS DOCUMENT SHALL NOT BE DISCLOSED, IN WHOLE OR PART, TO ANY UNAUTHORIZED PERSON OR ENTITY NOR REPRODUCED, TRANSFERRED OR INCORPORATED IN ANY OTHER PROJECT IN ANY MANNER WITHOUT THE EXPRESS WRITTEN CONSENT OF SAMTEC, INC.

DO NOT SCALE DRAWING

SHEET SCALE: 2.25:1



520 PARK EAST BLVD, NEW ALBANY, IN 47150  
PHONE: 812-944-6733 FAX: 812-948-5047  
e-Mail: info@SAMTEC.com code: 55322

DESCRIPTION:  
0.8mm HIGH SPEED EDGE CARD ASSEMBLY

DWG. NO.  
HSEC8-1XXX-XX-XX-DV-X-XX-X-XX

BY: BRATCHER 01/24/03 SHEET 2 OF 8

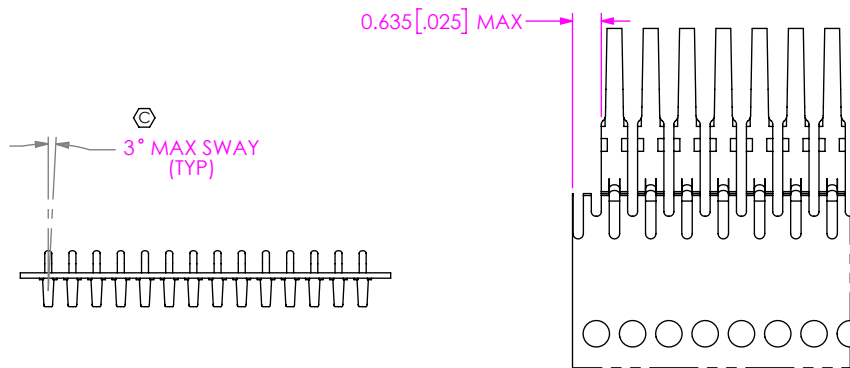

C-188-XXX-X IN-PROCESS VIEW

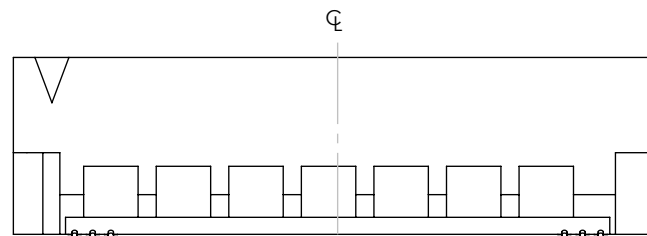

FIG 10  
 \*\*NON-ALIGNMENT PIN OPTION  
 HSEC8-130-01-XX-DV SHOWN  
 (DIFFERENT AS SHOWN, OTHERWISE SAME AS FIG 1)  
 (\*\* = AVAILABLE ONLY WITH -01 CARD THICKNESS)  
 (SOME FEATURES NOT SHOWN FOR CLARITY)

TABLE 9

CARD	OPTION 2	BODY	CONTACT	"P"	"Q"	"T"	"V"	"W"	"Y"
-01	-L	RHSEC8-XXX-01-DV-A-L	C-188-02-X	1.75[.069]	5.60[.220]	7.00[.276]	0.56[.022]	5.60[.220]	4.26[.168]
	-L2	RHSEC8-XXX-01-DV-A-L2	C-188-02-X					5.60[.220]	
	-BL	RHSEC8-XXX-01-DV-A-BL	C-188-02-X					5.60[.220]	
	-GR	RHSEC8-XXX-01-DV-XX-GR	C-188-02-X					5.60[.220]	
	-PE	HSEC8-XXX-01-DV-A-PE	C-188-01-X					4.60[.180]	
	-WT	RHSEC8-XXX-01-DV-A-WT	C-188-02-X					5.60[.220]	
	NONE	RHSEC8-XXX-01-DV-XX	C-188-02-X	5.60[.220]					
-03	NONE	RHSEC8-XXX-03-DV-A	C-188-02-X	2.54[.100]	6.39[.252]	7.79[.307]	1.35[.053]	6.39[.252]	5.05[.199]
	-WT	RHSEC8-XXX-03-DV-A-WT	C-188-02-X						

**PROPRIETARY NOTE**  
 THIS DOCUMENT CONTAINS CONFIDENTIAL AND PROPRIETARY INFORMATION AND ALL DESIGN, MANUFACTURING, REPRODUCTION, USE, PATENT RIGHTS AND SALES RIGHTS ARE EXPRESSLY RESERVED BY SAMTEC, INC. THIS DOCUMENT SHALL NOT BE DISCLOSED, IN WHOLE OR IN PART, TO ANY UNAUTHORIZED PERSON OR ENTITY NOR REPRODUCED, TRANSFERRED OR INCORPORATED IN ANY OTHER PROJECT IN ANY MANNER WITHOUT THE EXPRESS WRITTEN CONSENT OF SAMTEC, INC.

DO NOT SCALE DRAWING

SHEET SCALE: 2:1



520 PARK EAST BLVD, NEW ALBANY, IN 47150  
 PHONE: 812-944-6733 FAX: 812-948-5047  
 e-Mail info@SAMTEC.com code 55322

DESCRIPTION:  
 0.8mm HIGH SPEED EDGE CARD ASSEMBLY

DWG. NO.  
 HSEC8-1XXX-XX-XX-DV-X-XX-X-XX

BY: BRATCHER 01/24/03 SHEET 3 OF 8

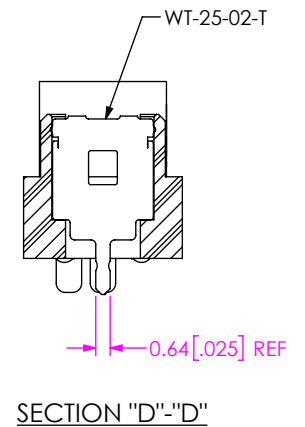
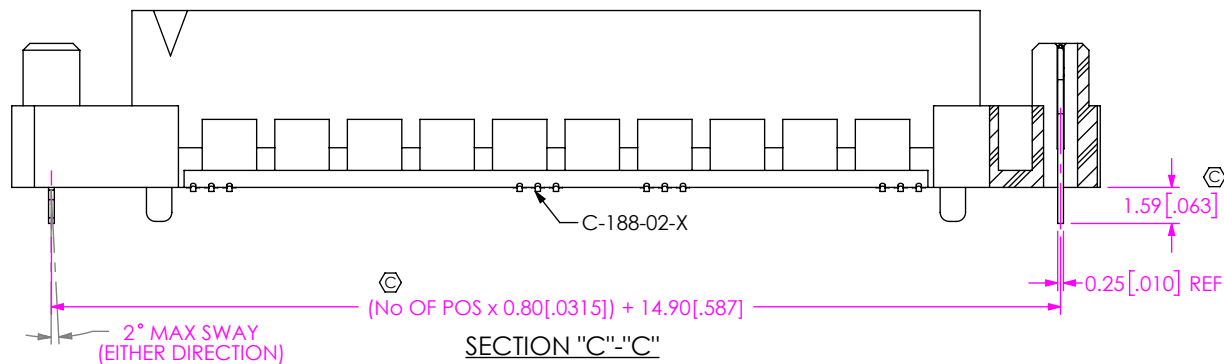
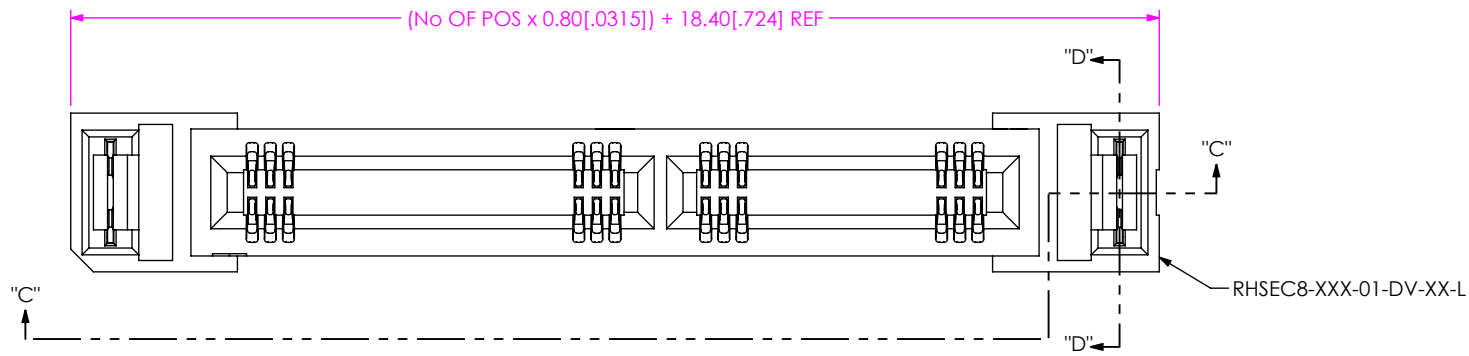

**FIG 4**  
**\*\*L: LATCHING OPTION**  
 HSEC8-137-01-XX-DV-A-L SHOWN  
 AVAILABLE IN -13, -25, -37 & -49 POSITIONS ONLY  
 (NOT AVAILABLE FOR -GR TYPE USE)  
 (DIFFERENT AS SHOWN, OTHERWISE SAME AS FIG 2)  
 (SOME FEATURES NOT SHOWN FOR CLARITY)  
 (\*\* = AVAILABLE ONLY WITH -01 CARD THICKNESS)

**PROPRIETARY NOTE**  
 THIS DOCUMENT CONTAINS CONFIDENTIAL AND PROPRIETARY INFORMATION AND ALL DESIGN, MANUFACTURING, REPRODUCTION, USE, PATENT RIGHTS AND SALES RIGHTS ARE EXPRESSLY RESERVED BY SAMTEC, INC. THIS DOCUMENT SHALL NOT BE DISCLOSED, IN WHOLE OR PART, TO ANY UNAUTHORIZED PERSON OR ENTITY NOR REPRODUCED, TRANSFERRED OR INCORPORATED IN ANY OTHER PROJECT IN ANY MANNER WITHOUT THE EXPRESS WRITTEN CONSENT OF SAMTEC, INC.

DO NOT SCALE DRAWING

SHEET SCALE: 3:1

**samtec**

520 PARK EAST BLVD, NEW ALBANY, IN 47150  
 PHONE: 812-944-6733 FAX: 812-948-5047  
 e-Mail: info@SAMTEC.com code: 55322

DESCRIPTION:  
 0.8mm HIGH SPEED EDGE CARD ASSEMBLY

DWG. NO.  
 HSEC8-1XXX-XX-XX-DV-X-XX-X-XX

BY: BRATCHER 01/24/03 SHEET 4 OF 8

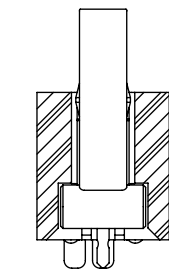
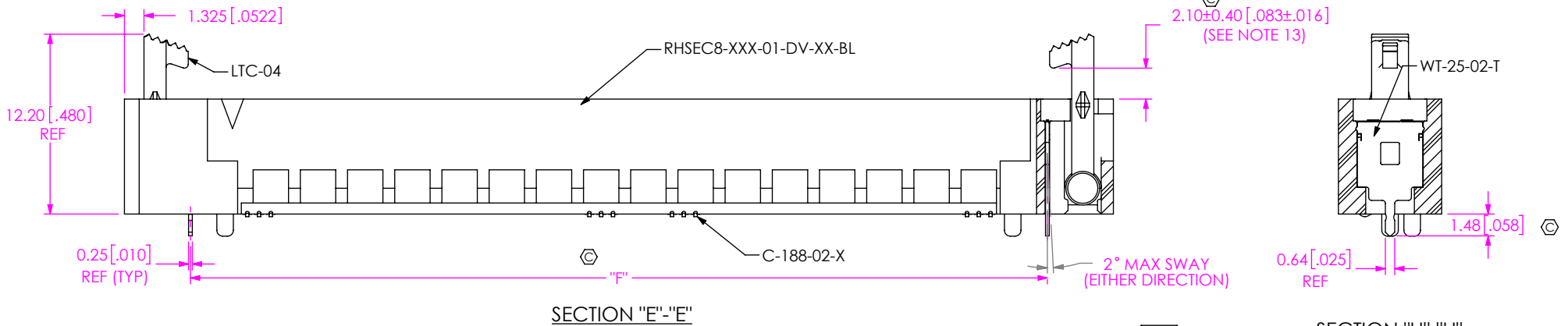
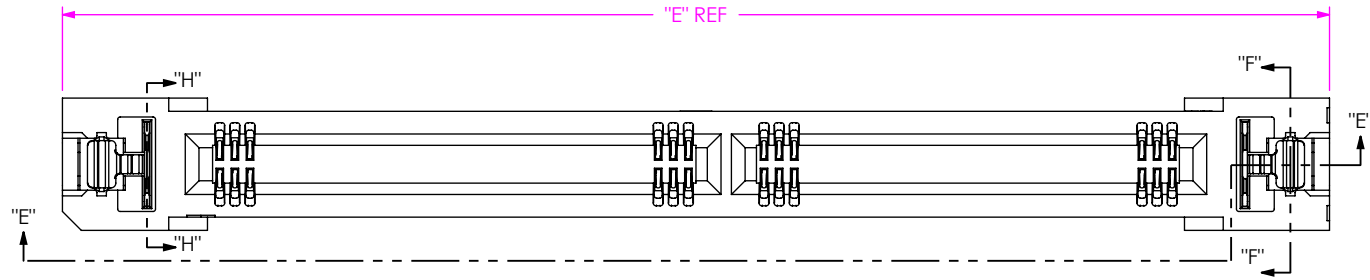
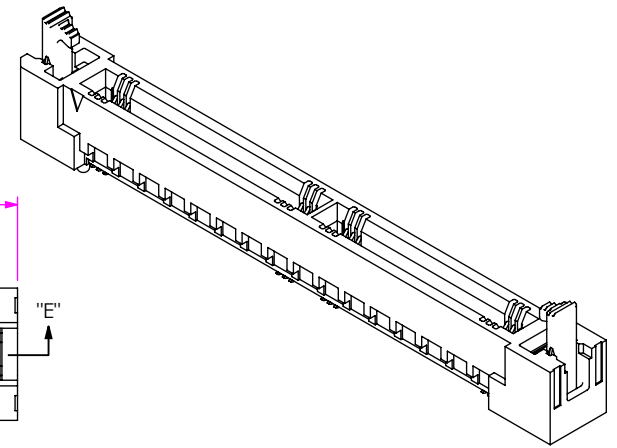

SECTION "E"-"E"

SECTION "H"-"H"

SECTION "F"-"F"

**TABLE 4**

No OF POSITIONS	"E"	"F"
-09	26.25 [1.033]	17.30 [0.681]
-10	23.85 [0.939]	14.90 [0.587]
-13	29.45 [1.159]	20.50 [0.807]
-20	31.85 [1.254]	22.90 [0.902]
-25	39.05 [1.537]	30.10 [1.185]
-30	39.85 [1.569]	30.90 [1.217]
-37	48.65 [1.915]	39.70 [1.563]
-40	51.05 [2.010]	42.10 [1.657]
-49	58.25 [2.293]	49.30 [1.941]
-50	59.05 [2.325]	50.10 [1.972]
-60	67.05 [2.640]	58.10 [2.287]
-70	75.05 [2.955]	66.10 [2.602]
-80	83.05 [3.270]	74.10 [2.917]
-90	91.05 [3.585]	82.10 [3.232]
-100	99.05 [3.900]	90.10 [3.547]

FIG 5

\*\*-BL: BOARD LOCK OPTION  
HSEC8-160-01-XX-DV-A-BL SHOWN  
(NOT AVAILABLE FOR -GR TYPE USE)  
(FOR -09, -13, -25, 37, -40, -49, -50, -60, -70, -80, -90 & -100  
POSITIONS DIFFERENT AS SHOWN, OTHERWISE SAME AS FIG 2)  
(FOR -10, -20 & -30 POSITIONS DIFFERENT AS SHOWN,  
OTHERWISE SAME AS FIG 1)  
(\*\* = AVAILABLE ONLY WITH -01 CARD THICKNESS)  
(SOME FEATURES NOT SHOWN FOR CLARITY)  
(AVAILABLE IN ALL POSITIONS)

**PROPRIETARY NOTE**  
THIS DOCUMENT CONTAINS CONFIDENTIAL AND  
PROPRIETARY INFORMATION AND ALL DESIGN,  
MANUFACTURING, REPRODUCTION, USE, PATENT RIGHTS  
AND SALES RIGHTS ARE EXPRESSLY RESERVED BY SAMTEC,  
INC. THIS DOCUMENT SHALL NOT BE DISCLOSED, IN WHOLE  
OR PART, TO ANY UNAUTHORIZED PERSON OR ENTITY NOR  
REPRODUCED, TRANSFERRED OR INCORPORATED IN ANY  
OTHER PROJECT IN ANY MANNER WITHOUT THE EXPRESS  
WRITTEN CONSENT OF SAMTEC, INC.

DO NOT SCALE DRAWING  
SHEET SCALE: 2.5:1



520 PARK EAST BLVD, NEW ALBANY, IN 47150  
PHONE: 812-944-6733 FAX: 812-948-5047  
e-Mail: info@SAMTEC.com code: 55322

DESCRIPTION:  
**0.8mm HIGH SPEED EDGE CARD ASSEMBLY**  
DWG. NO.  
**HSEC8-1XXX-XX-XX-DV-X-XX-X-XX**  
BY: BRATCHER 01/24/03 SHEET 5 OF 8

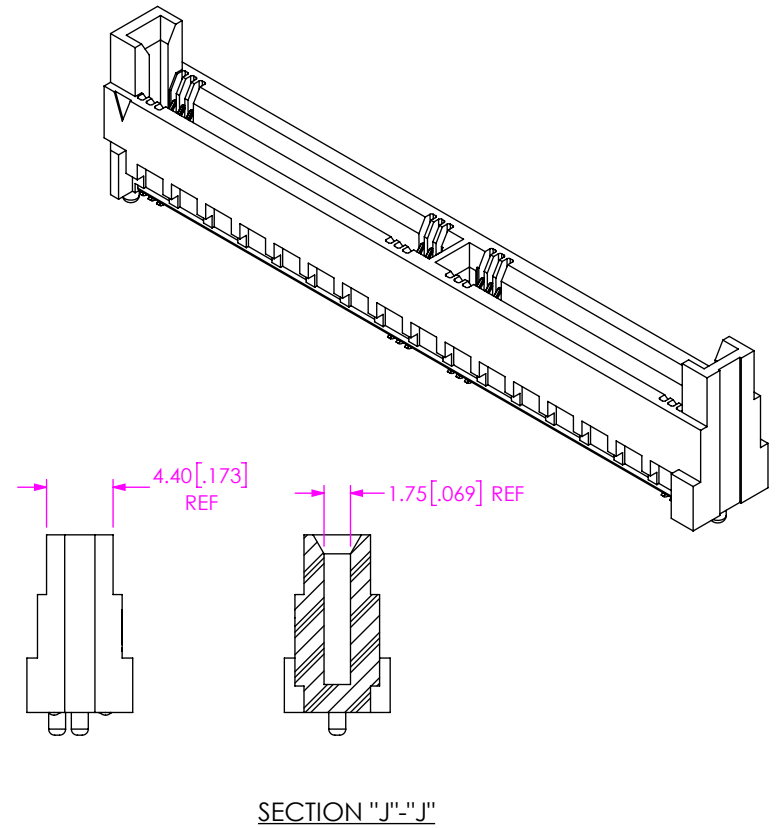
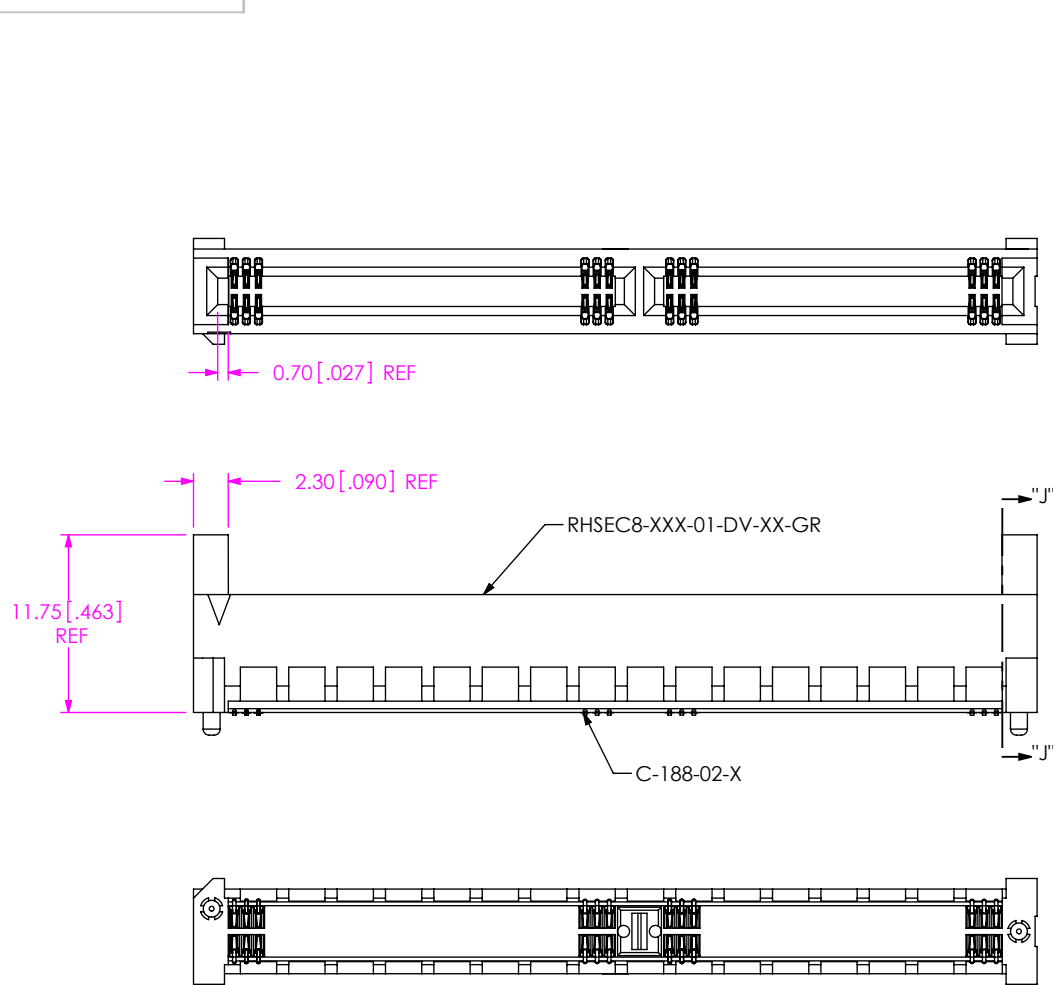

**FIG 6**  
 \*\*GR: GUIDE RAILS OPTION  
 HSEC8-160-01-XX-DV-A-GR SHOWN  
 AVAILABLE IN -10, -20, -30, -40, -50, & -60 POSITIONS ONLY  
 (NOT AVAILABLE FOR -L; -BL TYPE USE)  
 (DIFFERENT AS SHOWN, OTHERWISE SAME AS FIG 2)  
 (SOME FEATURES NOT SHOWN FOR CLARITY)  
 (\*\* = AVAILABLE ONLY WITH -01 CARD THICKNESS)

**PROPRIETARY NOTE**  
 THIS DOCUMENT CONTAINS CONFIDENTIAL AND PROPRIETARY INFORMATION AND ALL DESIGN, MANUFACTURING, REPRODUCTION, USE, PATENT RIGHTS AND SALES RIGHTS ARE EXPRESSLY RESERVED BY SAMTEC, INC. THIS DOCUMENT SHALL NOT BE DISCLOSED, IN WHOLE OR PART, TO ANY UNAUTHORIZED PERSON OR ENTITY NOR REPRODUCED, TRANSFERRED OR INCORPORATED IN ANY OTHER PROJECT IN ANY MANNER WITHOUT THE EXPRESS WRITTEN CONSENT OF SAMTEC, INC.

DO NOT SCALE DRAWING  
 SHEET SCALE: 2:1



520 PARK EAST BLVD, NEW ALBANY, IN 47150  
 PHONE: 812-944-6733 FAX: 812-948-5047  
 e-Mail: info@SAMTEC.com code: 55322

DESCRIPTION:  
 0.8mm HIGH SPEED EDGE CARD ASSEMBLY

DWG. NO.  
 HSEC8-1XXX-XX-XX-DV-X-XX-X-XX

BY: BRATCHER 01/24/03 SHEET 6 OF 8

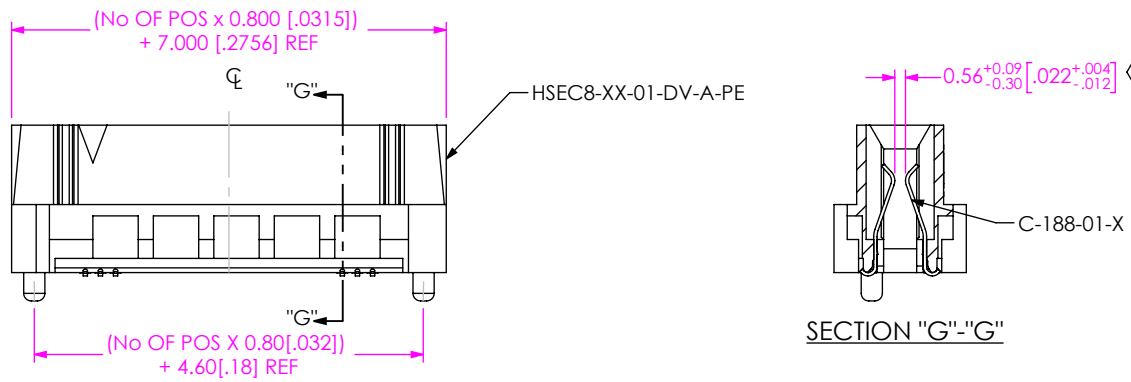

**FIG 7**  
 \*\*-PE: PASS THROUGH OPTION  
 HSEC8-120-01-XX-DV-A-PE SHOWN  
 AVAILABLE IN -10, \*-13 & -20 POSITIONS ONLY  
 (DIFFERENT AS SHOWN, OTHERWISE SAME AS FIG 1)  
 (SOME FEATURES NOT SHOWN FOR CLARITY)  
 \*\* = AVAILABLE ONLY WITH -01 CARD THICKNESS  
 \*-13 IS A ONE BANK PART

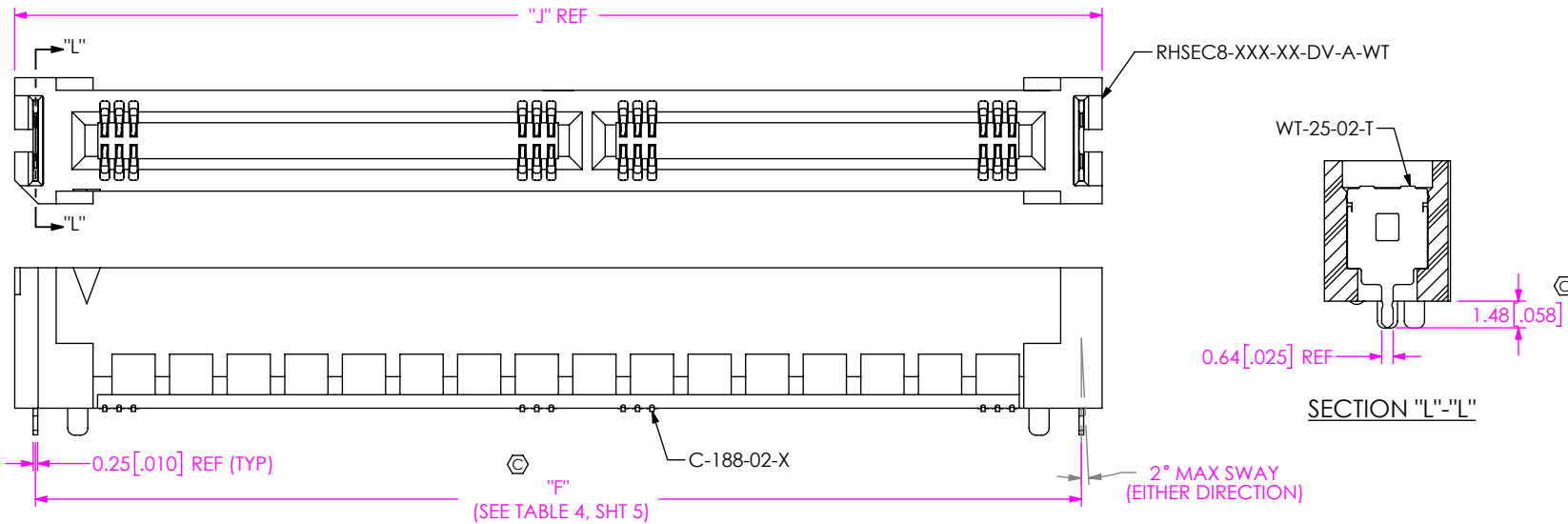

**TABLE 7**

No OF POSITIONS	"J"
-09	19.60 [0.772]
-10	17.20 [0.677]
-13	22.80 [0.898]
-20	25.20 [0.992]
-25	32.40 [1.276]
-30	33.20 [1.307]
-37	42.00 [1.654]
-40	44.40 [1.748]
-49	51.60 [2.031]
-50	52.40 [2.063]
-60	60.40 [2.378]
-70	68.40 [2.693]
-80	76.40 [3.008]
-90	84.40 [3.323]
-100	92.40 [3.638]

**FIG 8**  
 -WT: WELD TAB OPTION  
 HSEC8-160-01-XX-DV-A-WT SHOWN  
 AVAILABLE IN ALL POSITIONS  
 (-A OPTION REQUIRED)  
 (DIFFERENT AS SHOWN, OTHERWISE SAME AS FIG 2)  
 (SOME FEATURES NOT SHOWN FOR CLARITY)

**PROPRIETARY NOTE**  
 THIS DOCUMENT CONTAINS CONFIDENTIAL AND PROPRIETARY INFORMATION AND ALL DESIGN, MANUFACTURING, REPRODUCTION, USE, PATENT RIGHTS AND SALES RIGHTS ARE EXPRESSLY RESERVED BY SAMTEC, INC. THIS DOCUMENT SHALL NOT BE DISCLOSED, IN WHOLE OR PART, TO ANY UNAUTHORIZED PERSON OR ENTITY NOR REPRODUCED, TRANSFERRED OR INCORPORATED IN ANY OTHER PROJECT IN ANY MANNER WITHOUT THE EXPRESS WRITTEN CONSENT OF SAMTEC, INC.

DO NOT SCALE DRAWING  
 SHEET SCALE: 2.5:1

**samtec**  
 520 PARK EAST BLVD, NEW ALBANY, IN 47150  
 PHONE: 812-944-6733 FAX: 812-948-5047  
 e-Mail info@SAMTEC.com code 55322

DESCRIPTION:  
 0.8mm HIGH SPEED EDGE CARD ASSEMBLY

DWG. NO.  
**HSEC8-1XXX-XX-XX-DV-X-XX-X-XX**

BY: BRATCHER 01/24/03 SHEET 7 OF 8

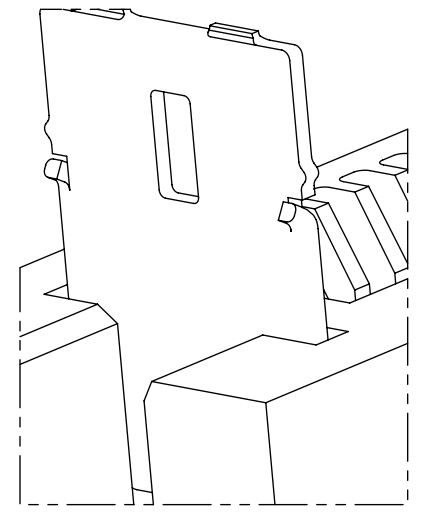
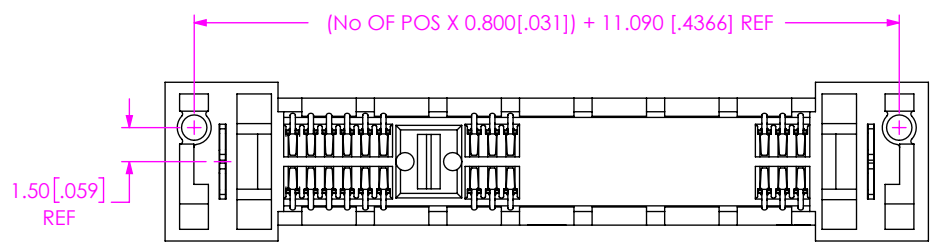
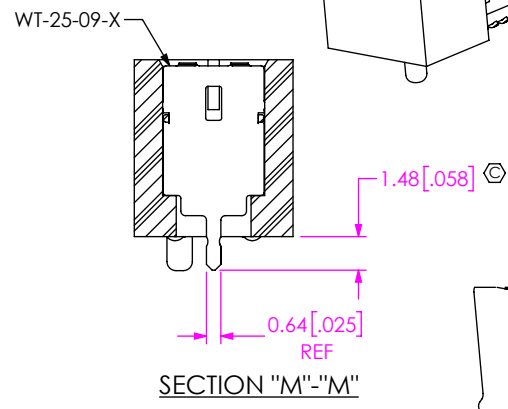
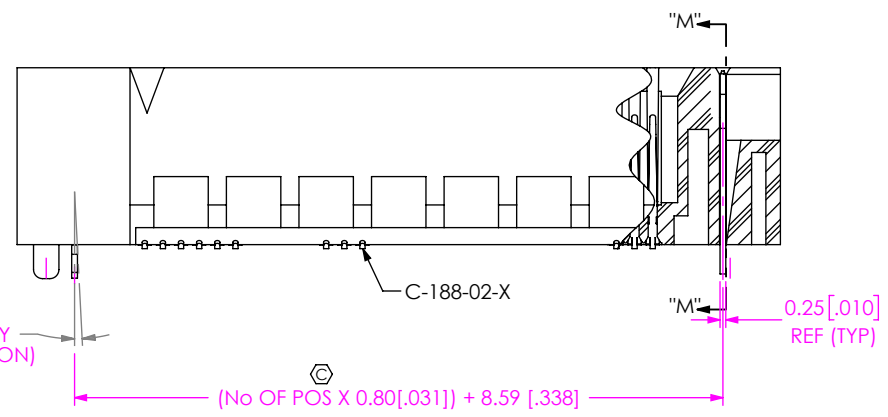
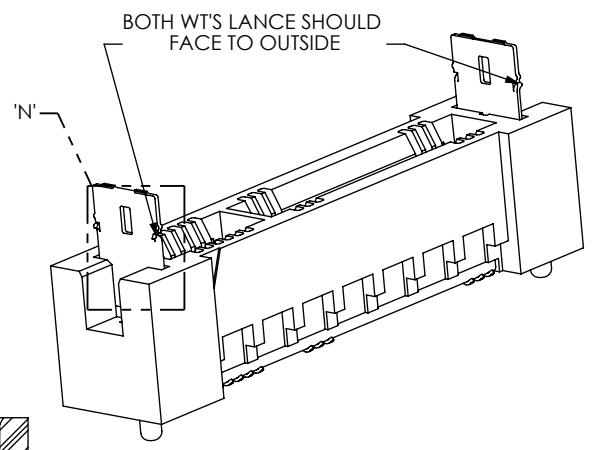
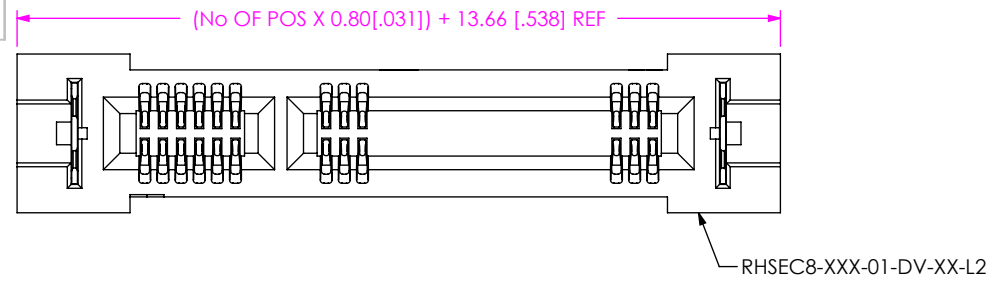

DETAIL 'N'  
SCALE 10 : 1

FIG 9  
 \*\*-L2: ECDP LATCHING OPTION  
 HSEC8-125-01-XX-DV-A-L2 SHOWN  
 (AVAILABLE IN 9, 13, 25, & 49 POS ONLY)  
 (NOT AVAILABLE FOR -GR TYPE USE)  
 (DIFFERENT AS SHOWN, OTHERWISE SAME AS FIG 2)  
 (SOME FEATURES NOT SHOWN FOR CLARITY)  
 (\*\* = AVAILABLE ONLY WITH -01 CARD THICKNESS)

c:\enterprisevault\DWG\MISC\MKTG\HSEC8-1XXX-XX-XX-DV-X-XX-X-XX-MKT.SLDDRW

**PROPRIETARY NOTE**  
 THIS DOCUMENT CONTAINS CONFIDENTIAL AND PROPRIETARY INFORMATION AND ALL DESIGN, MANUFACTURING, REPRODUCTION, USE, PATENT RIGHTS AND SALES RIGHTS ARE EXPRESSLY RESERVED BY SAMTEC, INC. THIS DOCUMENT SHALL NOT BE DISCLOSED, IN WHOLE OR PART, TO ANY UNAUTHORIZED PERSON OR ENTITY NOR REPRODUCED, TRANSFERRED OR INCORPORATED IN ANY OTHER PROJECT IN ANY MANNER WITHOUT THE EXPRESS WRITTEN CONSENT OF SAMTEC, INC.

DO NOT SCALE DRAWING  
 SHEET SCALE: 3:1

**samtec**  
 520 PARK EAST BLVD, NEW ALBANY, IN 47150  
 PHONE: 812-944-6733 FAX: 812-948-5047  
 e-Mail info@SAMTEC.com code 55322

DESCRIPTION:  
 0.8mm HIGH SPEED EDGE CARD ASSEMBLY  
 DWG. NO.  
 HSEC8-1XXX-XX-XX-DV-X-XX-X-XX  
 BY: BRATCHER 01/24/03 SHEET 8 OF 8