

**REVISION D**

DO NOT SCALE FROM THIS PRINT

**NOTES:**

1. Ⓢ REPRESENTS A CRITICAL DIMENSION.
2. PARTS TO BE PACKAGED IN TUBE.
3. SPECIAL GAGE AT-2019-049 TO BE USED FOR DIMENSIONS C1, C2, C4, C5 C6, C7 CHECK.

**DESIGNED & DIMENSIONED IN MILLIMETERS[INCHES]**

**PCI-E-XXX-02-X-D-RA**

**No OF POSITIONS**  
-036, -064, -098, -164  
(DOUBLE ROW)

**LEAD STYLE**  
-02: 1.57[.062"] THICK CARD

**PLATING SPECIFICATION**  
(VALUES GIVEN ARE IN MICRO INCHES)  
-S: 30u" MIN Au/50u" Ni IN CONTACT, MATING TIN ON TAIL  
-F: 3u" MIN Au/50u" Ni IN CONTACT, MATING TIN ON TAIL

**OPTION**  
-RA: RIGHT ANGLE

**ROW SPECIFICATION**  
-D: DOUBLE ROW

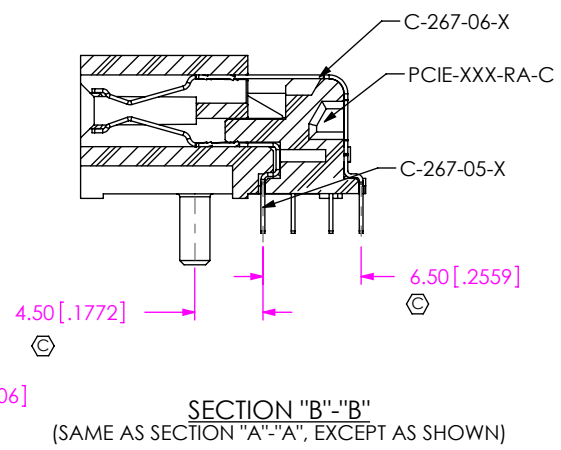
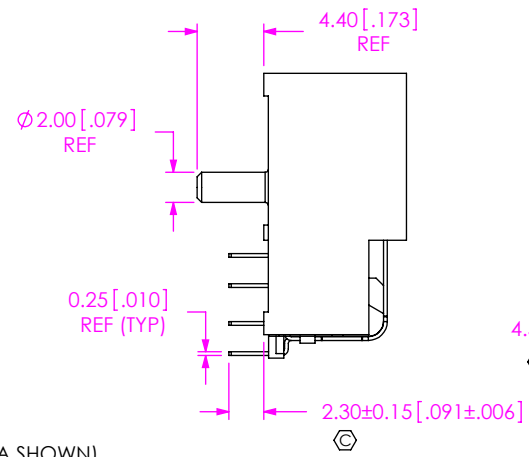
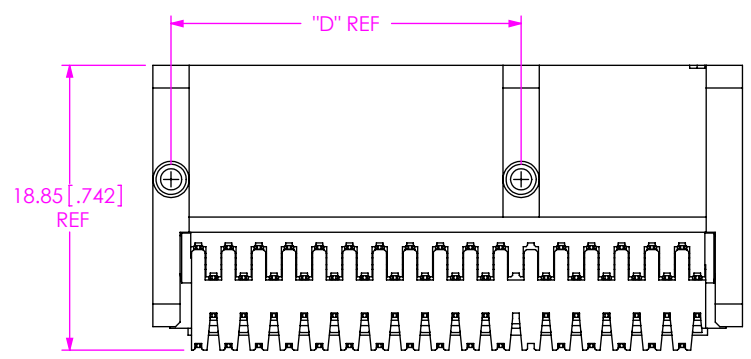
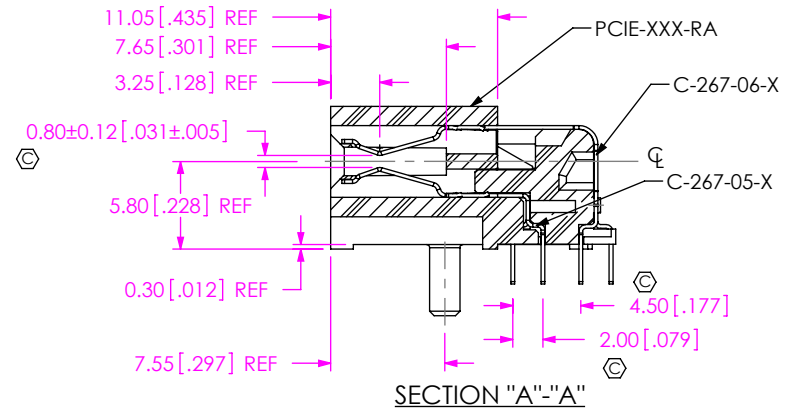
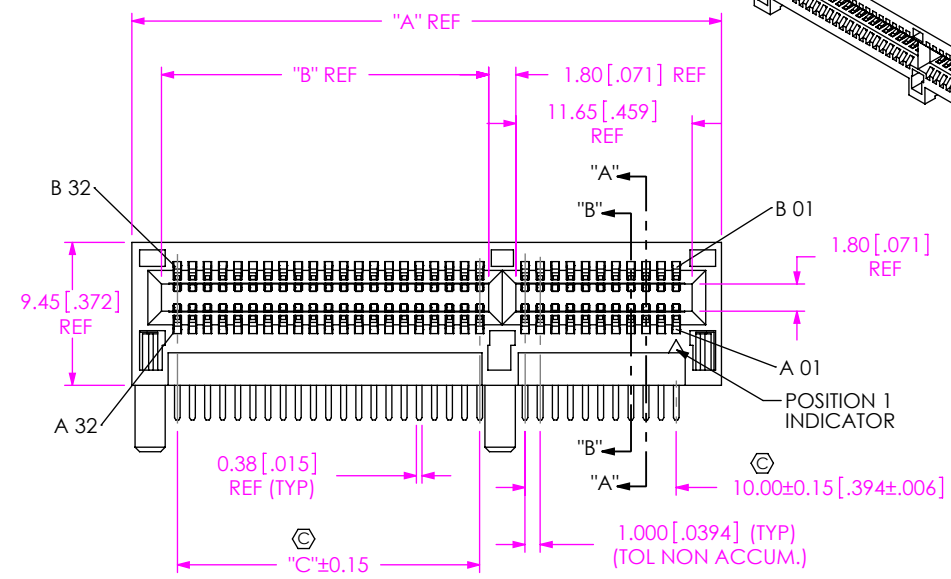
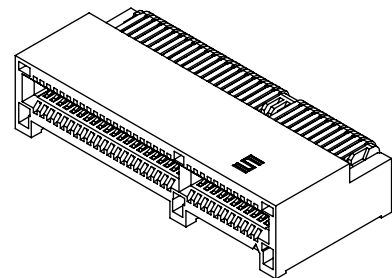

**FIG. 1**  
(PCI-E-064-02-X-D-RA SHOWN)

**SECTION "B"-"B"**  
(SAME AS SECTION "A"-"A", EXCEPT AS SHOWN)

**TABLE 1**

No. OF POS	"A"	"B"	"C"	"D"
-036	25.00 [0.984]	7.65 [0.301]	6.00 [0.236]	9.150 [0.3602]
-064	39.00 [1.535]	21.65 [0.852]	20.00 [0.787]	23.150 [0.9114]
-098	56.00 [2.205]	38.65 [1.522]	37.00 [1.457]	40.150 [1.5807]
-164	89.00 [3.504]	71.65 [2.821]	70.00 [2.756]	73.150 [2.8799]

**UNLESS OTHERWISE SPECIFIED, DIMENSIONS ARE IN MILLIMETERS[INCHES]. TOLERANCES ARE:**  
DECIMALS ANGLES  
X.X: ±0.3 [0.1]  
X.XX: ±0.13 [0.05]  
X.XXX: ±0.051 [0.020]

**PROPRIETARY NOTE**  
THIS DOCUMENT CONTAINS CONFIDENTIAL AND PROPRIETARY INFORMATION AND ALL DESIGN, MANUFACTURING, REPRODUCTION, USE, PATENT RIGHTS AND SALES RIGHTS ARE EXPRESSLY RESERVED BY SAMTEC, INC. THIS DOCUMENT SHALL NOT BE DISCLOSED, IN WHOLE OR PART, TO ANY UNAUTHORIZED PERSON OR ENTITY NOR REPRODUCED, TRANSFERRED OR INCORPORATED IN ANY OTHER PROJECT IN ANY MANNER WITHOUT THE EXPRESS WRITTEN CONSENT OF SAMTEC, INC.

**MATERIAL:** DO NOT SCALE DRAWING SHEET SCALE: 2:1  
INSULATOR: LCP, COLOR: BLACK  
CONTACT: PHOS BRONZE



520 PARK EAST BLVD. NEW ALBANY, IN 47150  
PHONE: 812-944-6733 FAX: 812-948-5047  
e-Mail: info@SAMTEC.com code 55322

**DESCRIPTION:** PCI EXPRESS RIGHT ANGLE ASSEMBLY  
**DWG. NO.:** PCI-E-XXX-02-X-D-RA  
**BY:** ROY LUO 10/21/2009 **SHEET 1 OF 3**

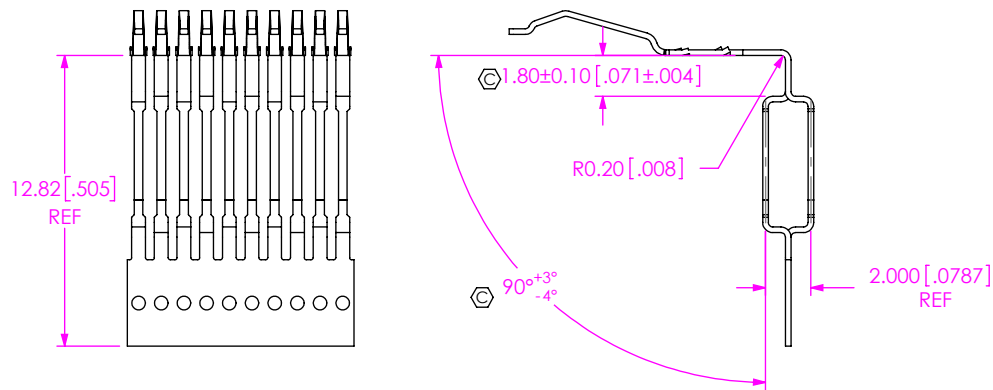

IN-PROCESS 1  
(FORM CONTACT C-267-05-X)

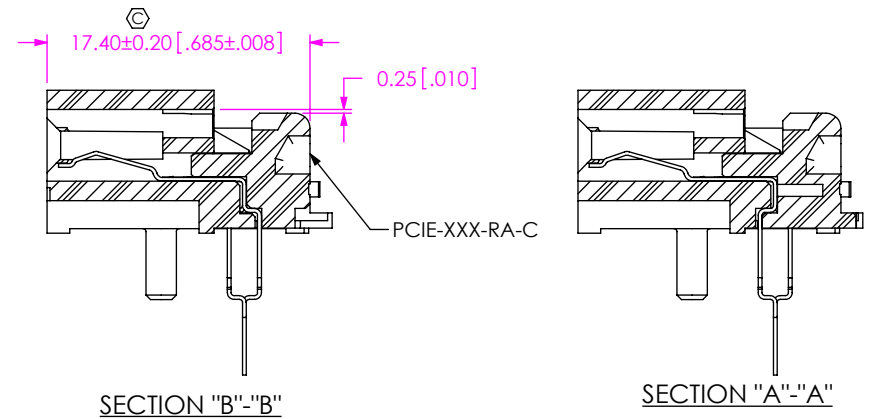

IN-PROCESS 3  
(FILL PCI-E-XXX-RA-C)

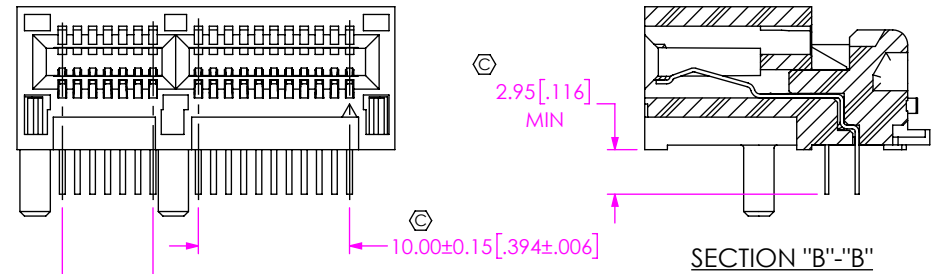

IN-PROCESS 4  
(CUTOFF OF CARRIER)

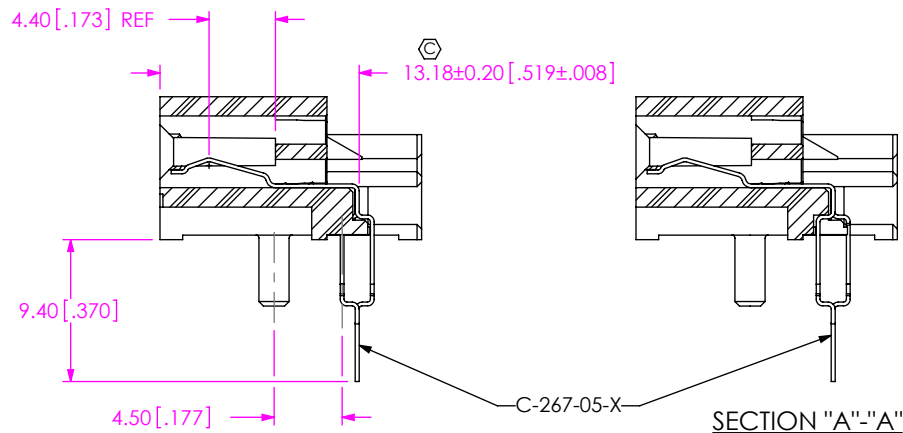

SECTION "B"-"B"

SECTION "A"-"A"

IN-PROCESS 2  
(FILL BOTTOM ROW)

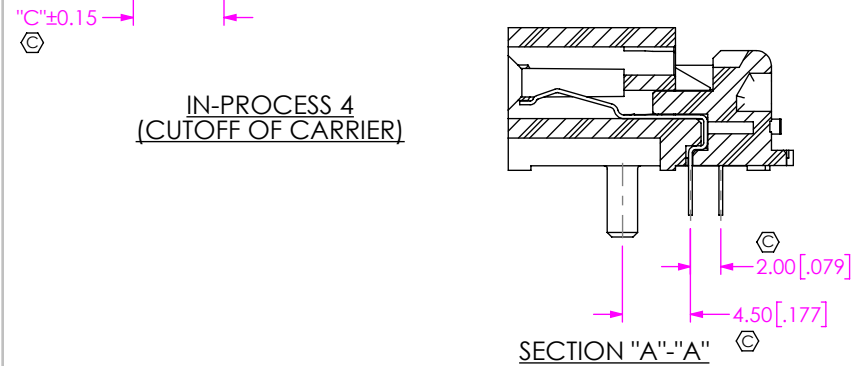

SECTION "A"-"A"

F:\DWG\SW\Exisprod\Assembly\Io\PCI-E-XXX-02-X-D-RA-ASM.SLDDRW

**PROPRIETARY NOTE**  
THIS DOCUMENT CONTAINS CONFIDENTIAL AND PROPRIETARY INFORMATION AND ALL DESIGN, MANUFACTURING, REPRODUCTION, USE, PATENT RIGHTS AND SALES RIGHTS ARE EXPRESSLY RESERVED BY SAMTEC, INC. THIS DOCUMENT SHALL NOT BE DISCLOSED, IN WHOLE OR PART, TO ANY UNAUTHORIZED PERSON OR ENTITY NOR REPRODUCED, TRANSFERRED OR INCORPORATED IN ANY OTHER PROJECT IN ANY MANNER WITHOUT THE EXPRESS WRITTEN CONSENT OF SAMTEC, INC.

DO NOT SCALE DRAWING

SHEET SCALE: 2:1

**samtec**

520 PARK EAST BLVD, NEW ALBANY, IN 47150  
PHONE: 812-944-6733 FAX: 812-948-5047  
e-Mail info@SAMTEC.com code 55322

DESCRIPTION:  
PCI EXPRESS RIGHT ANGLE ASSEMBLY

DWG. NO.  
PCI-E-XXX-02-X-D-RA

BY: ROY LUO 10/21/2009 SHEET 2 OF 3

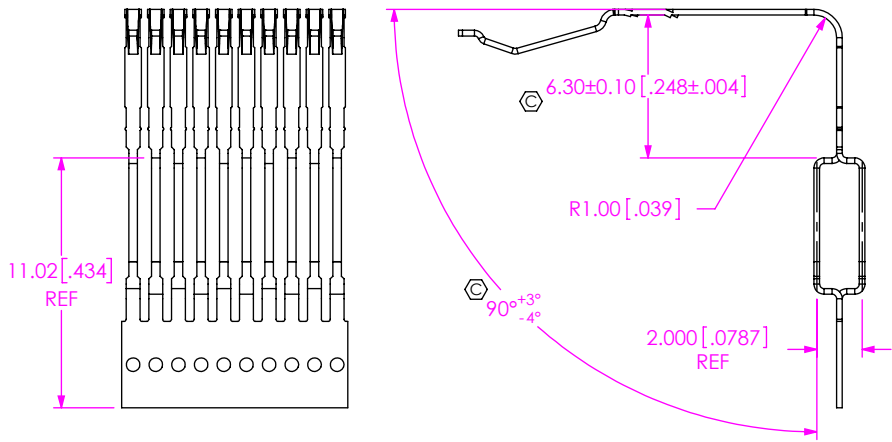

IN-PROCESS 5  
(FORM CONTACT C-267-06-X)

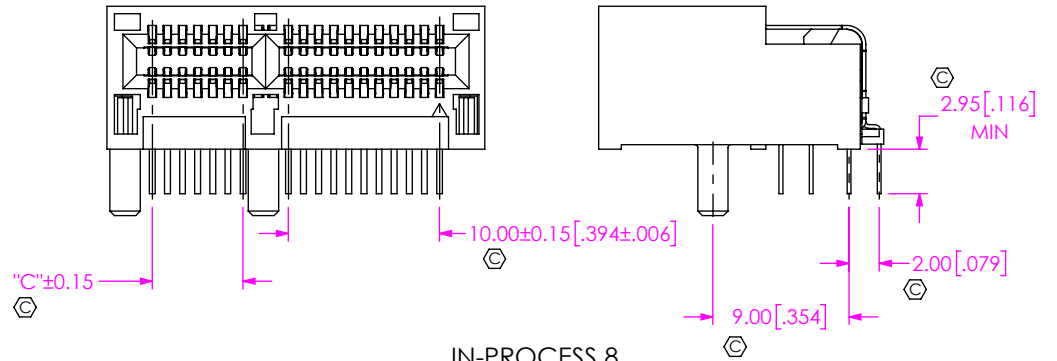

IN-PROCESS 8  
(CUT OFF TOP  
CONTACT CARRIER)

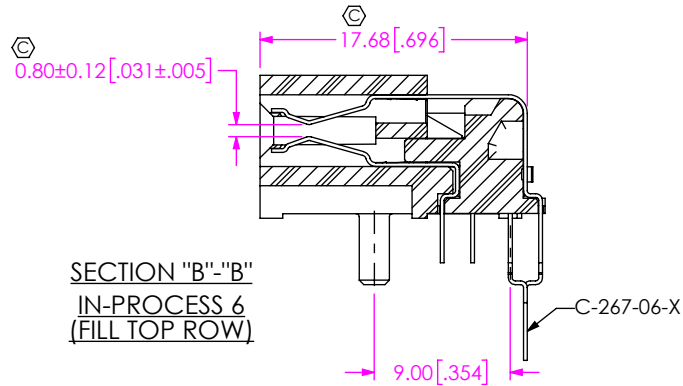

SECTION "B"-"B"  
IN-PROCESS 6  
(FILL TOP ROW)

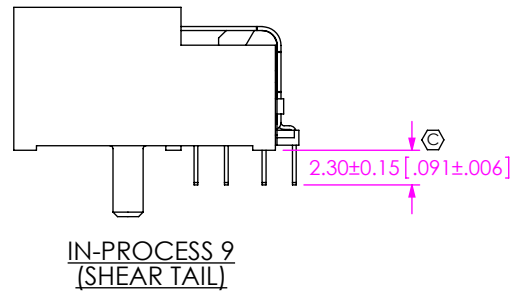

IN-PROCESS 9  
(SHEAR TAIL)

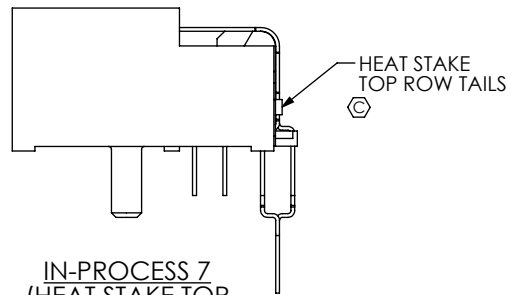

IN-PROCESS 7  
(HEAT STAKE TOP  
ROW CONTACTS)

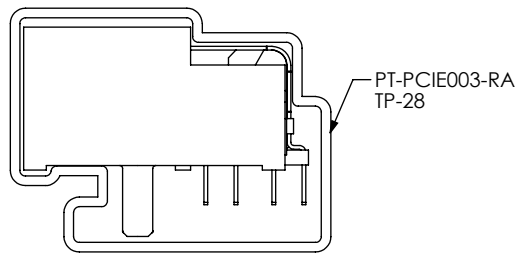

PACKAGING VIEW

F:\DWG\SW\Exisprod\Assembly\lo\PCIE-XXX-02-X-D-RA-ASM.SLDDRW

**PROPRIETARY NOTE**  
THIS DOCUMENT CONTAINS CONFIDENTIAL AND PROPRIETARY INFORMATION AND ALL DESIGN, MANUFACTURING, REPRODUCTION, USE, PATENT RIGHTS AND SALES RIGHTS ARE EXPRESSLY RESERVED BY SAMTEC, INC. THIS DOCUMENT SHALL NOT BE DISCLOSED, IN WHOLE OR PART, TO ANY UNAUTHORIZED PERSON OR ENTITY NOR REPRODUCED, TRANSFERRED OR INCORPORATED IN ANY OTHER PROJECT IN ANY MANNER WITHOUT THE EXPRESS WRITTEN CONSENT OF SAMTEC, INC.

DO NOT SCALE DRAWING

SHEET SCALE: 2:1



520 PARK EAST BLVD, NEW ALBANY, IN 47150  
PHONE: 812-944-6733 FAX: 812-948-5047  
e-Mail info@SAMTEC.com code 55322

DESCRIPTION:  
PCI EXPRESS RIGHT ANGLE ASSEMBLY

DWG. NO. **PCIE-XXX-02-X-D-RA**

BY: ROY LUO 10/21/2009 SHEET 3 OF 3