

S29AL032D

32 Megabit CMOS 3.0 Volt-only Flash Memory

4 M x 8-Bit Uniform Sector

4 M x 8-Bit/2 M x 16-Bit Boot Sector



Data Sheet

Notice to Readers: This document states the current technical specifications regarding the Spansion product(s) described herein. Spansion LLC deems the products to have been in sufficient production volume such that subsequent versions of this document are not expected to change. However, typographical or specification corrections, or modifications to the valid combinations offered may occur.

Notice On Data Sheet Designations

SpanSion LLC issues data sheets with Advance Information or Preliminary designations to advise readers of product information or intended specifications throughout the product life cycle, including development, qualification, initial production, and full production. In all cases, however, readers are encouraged to verify that they have the latest information before finalizing their design. The following descriptions of SpanSion data sheet designations are presented here to highlight their presence and definitions.

Advance Information

The Advance Information designation indicates that SpanSion LLC is developing one or more specific products, but has not committed any design to production. Information presented in a document with this designation is likely to change, and in some cases, development on the product may discontinue. SpanSion LLC therefore places the following conditions upon Advance Information content:

"This document contains information on one or more products under development at SpanSion LLC. The information is intended to help you evaluate this product. Do not design in this product without contacting the factory. SpanSion LLC reserves the right to change or discontinue work on this proposed product without notice."

Preliminary

The Preliminary designation indicates that the product development has progressed such that a commitment to production has taken place. This designation covers several aspects of the product life cycle, including product qualification, initial production, and the subsequent phases in the manufacturing process that occur before full production is achieved. Changes to the technical specifications presented in a Preliminary document should be expected while keeping these aspects of production under consideration. SpanSion places the following conditions upon Preliminary content:

"This document states the current technical specifications regarding the SpanSion product(s) described herein. The Preliminary status of this document indicates that product qualification has been completed, and that initial production has begun. Due to the phases of the manufacturing process that require maintaining efficiency and quality, this document may be revised by subsequent versions or modifications due to changes in technical specifications."

Combination

Some data sheets will contain a combination of products with different designations (Advance Information, Preliminary, or Full Production). This type of document will distinguish these products and their designations wherever necessary, typically on the first page, the ordering information page, and pages with DC Characteristics table and AC Erase and Program table (in the table notes). The disclaimer on the first page refers the reader to the notice on this page.

Full Production (No Designation on Document)

When a product has been in production for a period of time such that no changes or only nominal changes are expected, the Preliminary designation is removed from the data sheet. Nominal changes may include those affecting the number of ordering part numbers available, such as the addition or deletion of a speed option, temperature range, package type, or V_{IO} range. Changes may also include those needed to clarify a description or to correct a typographical error or incorrect specification. SpanSion LLC applies the following conditions to documents in this category:

"This document states the current technical specifications regarding the SpanSion product(s) described herein. SpanSion LLC deems the products to have been in sufficient production volume such that subsequent versions of this document are not expected to change. However, typographical or specification corrections, or modifications to the valid combinations offered may occur."

Questions regarding these document designations may be directed to your local AMD or Fujitsu sales office.

S29AL032D

32 Megabit CMOS 3.0 Volt-only Flash Memory
4 M x 8-Bit Uniform Sector
4 M x 8-Bit/2 M x 16-Bit Boot Sector



Data Sheet

Distinctive Characteristics

Architectural Advantages

- **Single power supply operation**
 - Full voltage range: 2.7 to 3.6 volt read and write operations for battery-powered applications
- **Manufactured on 200-nm process technology**
 - Fully compatible with 0.23 μm Am29LV320D, 0.32 μm Am29LV033C, and 0.33 μm MBM29LV320E devices
- **Flexible sector architecture**
 - Boot sector models: Eight 8-Kbyte sectors; sixty-three 64-Kbyte sectors; top or bottom boot block configurations available
 - Uniform sector models: Sixty-four 64-Kbyte sectors
- **Sector Protection features**
 - A hardware method of locking a sector to prevent any program or erase operations within that sector
 - Sectors can be locked in-system or via programming equipment
 - Temporary Sector Unprotect feature allows code changes in previously locked sectors
- **Unlock Bypass Program Command**
 - Reduces overall programming time when issuing multiple program command sequences
- **Secured Silicon Sector**
 - 128-word sector for permanent, secure identification through an 8-word random Electronic Serial Number
 - May be programmed and locked at the factory or by the customer
 - Accessible through a command sequence
- **Compatibility with JEDEC standards**
 - Pinout and software compatible with single-power supply Flash
 - Superior inadvertent write protection

Package Options

- **48-ball FBGA**
- **48-pin TSOP**
- **40-pin TSOP**

Performance Characteristics

- **High performance**
 - Access times as fast as 70 ns

- **Ultra low power consumption (typical values at 5 MHz)**
 - 200 nA Automatic Sleep mode current
 - 200 nA standby mode current
 - 9 mA read current
 - 20 mA program/erase current
- **Cycling endurance: 1,000,000 cycles per sector typical**
- **Data retention: 20 years typical**

Software Features

- **CFI (Common Flash Interface) compliant**
 - Provides device-specific information to the system, allowing host software to easily reconfigure for different Flash devices
- **Erase Suspend/Erase Resume**
 - Suspends an erase operation to read data from, or program data to, a sector that is not being erased, then resumes the erase operation
- **Data# Polling and toggle bits**
 - Provides a software method of detecting program or erase operation completion
 - Unlock Bypass Program Command
Reduces overall programming time when issuing multiple program command sequences

Hardware Features

- **Ready/Busy# pin (RY/BY#)**
 - Provides a hardware method of detecting program or erase cycle completion
- **Hardware reset pin (RESET#)**
 - Hardware method to reset the device to reading array data
- **WP#/ACC input pin**
 - Write protect (WP#) function allows protection of two outermost boot sectors (boot sector models only), regardless of sector protect status
 - Acceleration (ACC) function provides accelerated program times

General Description

The S29AL032D is a 32-megabit, 3.0 volt-only flash memory device, organized as 2,097,152 words of 16 bits each or 4,194,304 bytes of 8 bits each. Word mode data appears on DQ0-DQ15; byte mode data appears on DQ0-DQ7. The device is designed to be programmed in-system with the standard 3.0 volt VCC supply, and can also be programmed in standard EPROM programmers.

The device is available with access times as fast as 70 ns. The devices are offered in 40-pin TSOP, 48-pin TSOP and 48-ball FBGA packages. Standard control pins- chip enable (CE#), write enable (WE#), and output enable (OE#)-control normal read and write operations, and avoid bus contention issues.

The device requires only a **single 3.0 volt power supply** for both read and write functions. Internally generated and regulated voltages are provided for the pro-gram and erase operations.

S29AL032D Features

The **Secured Silicon Sector** is an extra sector capable of being permanently locked by SpanSion or customers. The **Secured Silicon Indicator Bit** (DQ7) is permanently set to a 1 if the part is **factory locked**, and set to a 0 if customer lockable. This way, customer lockable parts can never be used to replace a factory locked part. **Note that the S29AL032D has a Secured Silicon Sector size of 128 words (256 bytes).**

Factory locked parts provide several options. The Secured Silicon Sector may store a secure, random 16 byte ESN (Electronic Serial Number), customer code (programmed through the SpanSion programming service), or both.

The S29AL032D is entirely command set compatible with the **JEDEC single-power-supply Flash standard**. Commands are written to the command register using standard microprocessor write timings. Register contents serve as input to an internal state-machine that controls the erase and programming circuitry. Write cycles also internally latch addresses and data needed for the programming and erase operations. Reading data out of the device is similar to reading from other Flash or EPROM devices.

Device programming occurs by executing the program command sequence. This initiates the **Embedded Program** algorithm—an internal algorithm that automatically times the program pulse widths and verifies proper cell margin. The **Unlock Bypass** mode facilitates faster programming times by requiring only two write cycles to program data instead of four.

Device erasure occurs by executing the erase command sequence. This initiates the **Embedded Erase** algorithm—an internal algorithm that automatically preprograms the array (if it is not already programmed) before executing the erase operation. During erase, the device automatically times the erase pulse widths and verifies proper cell margin.

The host system can detect whether a program or erase operation is complete by observing the RY/BY# pin, or by reading the DQ7 (Data# Polling) and DQ6 (toggle) **status bits**. After a program or erase cycle has been completed, the device is ready to read array data or accept another command.

The **sector erase architecture** allows memory sectors to be erased and reprogrammed without affecting the data contents of other sectors. The device is fully erased when shipped from the factory.

Hardware data protection measures include a low V_{CC} detector that automatically inhibits write operations during power transitions. The **hardware sector protection** feature disables both program and erase operations in any combination of the sectors of memory. This can be achieved in-system or via programming equipment.

The **Erase Suspend/Erase Resume** feature enables the user to put erase on hold for any period of time to read data from, or program data to, any sector that is not selected for erasure. True background erase can thus be achieved.

The **hardware RESET# pin** terminates any operation in progress and resets the internal state machine to reading array data. The RESET# pin may be tied to the system reset circuitry. A system reset would thus also reset the device, enabling the system microprocessor to read the boot-up firmware from the Flash memory.

The device offers two power-saving features. When addresses are stable for a specified amount of time, the device enters the **automatic sleep mode**. The system can also place the device into the **standby mode**. Power consumption is greatly reduced in both these modes.

The Spansion Flash technology combines years of Flash memory manufacturing experience to produce the highest levels of quality, reliability and cost effectiveness. The device electrically erases all bits within a sector simultaneously via Fowler-Nordheim tunneling. The data is programmed using hot-electron injection.

Table of Contents

Notice On Data Sheet Designations	ii	Erase Suspend/Erase Resume Commands	34
Product Selector Guide	5	Figure 5. Erase Operation	35
Block Diagram	5	Command Definitions	36
Connection Diagrams	6	Table 16. S29AL032D Command Definitions — Model 00	36
Pin Configuration	9	Table 17. S29AL032D Command Definitions — Models 03, 04	37
Logic Symbol	9	Write Operation Status	38
Ordering Information	10	DQ7: Data# Polling	38
Device Bus Operations	11	Figure 6. Data# Polling Algorithm	39
Table 1. S29AL032D Device Bus Operations	11	RY/BY#: Ready/Busy#	39
Word/Byte Configuration (Models 03, 04 Only)	11	DQ6: Toggle Bit I	40
Requirements for Reading Array Data	11	DQ2: Toggle Bit II	40
Writing Commands/Command Sequences	12	Reading Toggle Bits DQ6/DQ2	41
Program and Erase Operation Status	12	Figure 7. Toggle Bit Algorithm	42
Accelerated Program Operation	12	DQ5: Exceeded Timing Limits	42
Standby Mode	13	DQ3: Sector Erase Timer	43
Automatic Sleep Mode	13	Table 18. Write Operation Status	43
RESET#: Hardware Reset Pin	13	Absolute Maximum Ratings	44
Output Disable Mode	13	Figure 8. Maximum Negative Overshoot Waveform	44
Table 2. Model 00 Sector Addresses	14	Figure 9. Maximum Positive Overshoot Waveform	44
Table 3. Model 00 Secured Silicon Sector Addresses	15	Operating Ranges	44
Table 4. Model 03 Sector Addresses	16	DC Characteristics	45
Table 5. Model 03 Secured Silicon Sector Addresses	17	Figure 10. I _{CC1} Current vs. Time (Showing Active and	46
Table 6. Model 04 Sector Addresses	18	Automatic Sleep Currents)	46
Table 7. Model 04 Secured Silicon Sector Addresses	19	Figure 11. Typical I _{CC1} vs. Frequency	46
Autoselect Mode	20	Test Conditions	47
Table 8. S29AL032D Autoselect Codes (High Voltage Method)	20	Figure 12. Test Setup	47
Sector Protection/Unprotection	20	Table 19. Test Specifications	47
Table 9. Sector Block Addresses for Protection/Unprotection — Model 00	21	Figure 13. Input Waveforms and Measurement Levels	48
Table 10. Sector Block Addresses for Protection/Unprotection — Model	03	AC Characteristics	49
Table 11. Sector Block Addresses for Protection/Unprotection — Model 04	23	Read Operations	49
Write Protect (WP#) — Models 03, 04 Only	23	Figure 14. Read Operations Timings	49
Temporary Sector Unprotect	24	Hardware Reset (RESET#)	50
Figure 1. Temporary Sector Unprotect Operation	24	Figure 15. RESET# Timings	50
Figure 2. In-System Sector Protect/Unprotect Algorithms	25	Figure 16. BYTE# Timings for Read Operations	51
Secured Silicon Sector Flash Memory Region	26	Figure 17. BYTE# Timings for Write Operations	52
Figure 3. Secured Silicon Sector Protect Verify	27	Erase/Program Operations	53
Hardware Data Protection	27	Figure 18. Program Operation Timings	54
Common Flash Memory Interface (CFI)	28	Figure 19. Chip/Sector Erase Operation Timings	55
Table 12. CFI Query Identification String	28	Figure 20. Back to Back Read/Write Cycle Timing	55
Table 13. System Interface String	29	Figure 21. Data# Polling Timings (During Embedded Algorithms)	56
Table 14. Device Geometry Definition	29	Figure 22. Toggle Bit Timings (During Embedded Algorithms)	56
Table 15. Primary Vendor-Specific Extended Query	30	Figure 23. DQ2 vs. DQ6 for Erase and Erase Suspend Operations	57
Command Definitions	30	Figure 24. Temporary Sector Unprotect/Timing Diagram	57
Reading Array Data	31	Figure 25. Accelerated Program Timing Diagram	58
Reset Command	31	Figure 26. Sector Protect/Unprotect Timing Diagram	58
Autoselect Command Sequence	31	Figure 27. Alternate CE# Controlled Write Operation Timings	60
Enter Secured Silicon Sector/Exit Secured Silicon Sector	32	Erase and Programming Performance	61
Command Sequence	32	TSOP and BGA Pin Capacitance	61
Word/Byte Program Command Sequence	32	Physical Dimensions	62
Figure 4. Program Operation	33	TS040—40-Pin Standard TSOP	62
Chip Erase Command Sequence	33	TS 048—48-Pin Standard TSOP	63
Sector Erase Command Sequence	34	VBN048—48-Ball Fine-Pitch Ball Grid Array (FBGA)	64
		10.0 x 6.0 mm	64
		Revision Summary	65

Product Selector Guide

Family Part Number		S29AL032D	
Speed Option	Voltage Range: $V_{CC} = 2.7\text{--}3.6\text{ V}$	70	90
Max access time, ns (t_{ACC})		70	90
Max CE# access time, ns (t_{CE})		70	90
Max OE# access time, ns (t_{OE})		30	35

Note: See *AC Characteristics on page 49* for full specifications.

Block Diagram

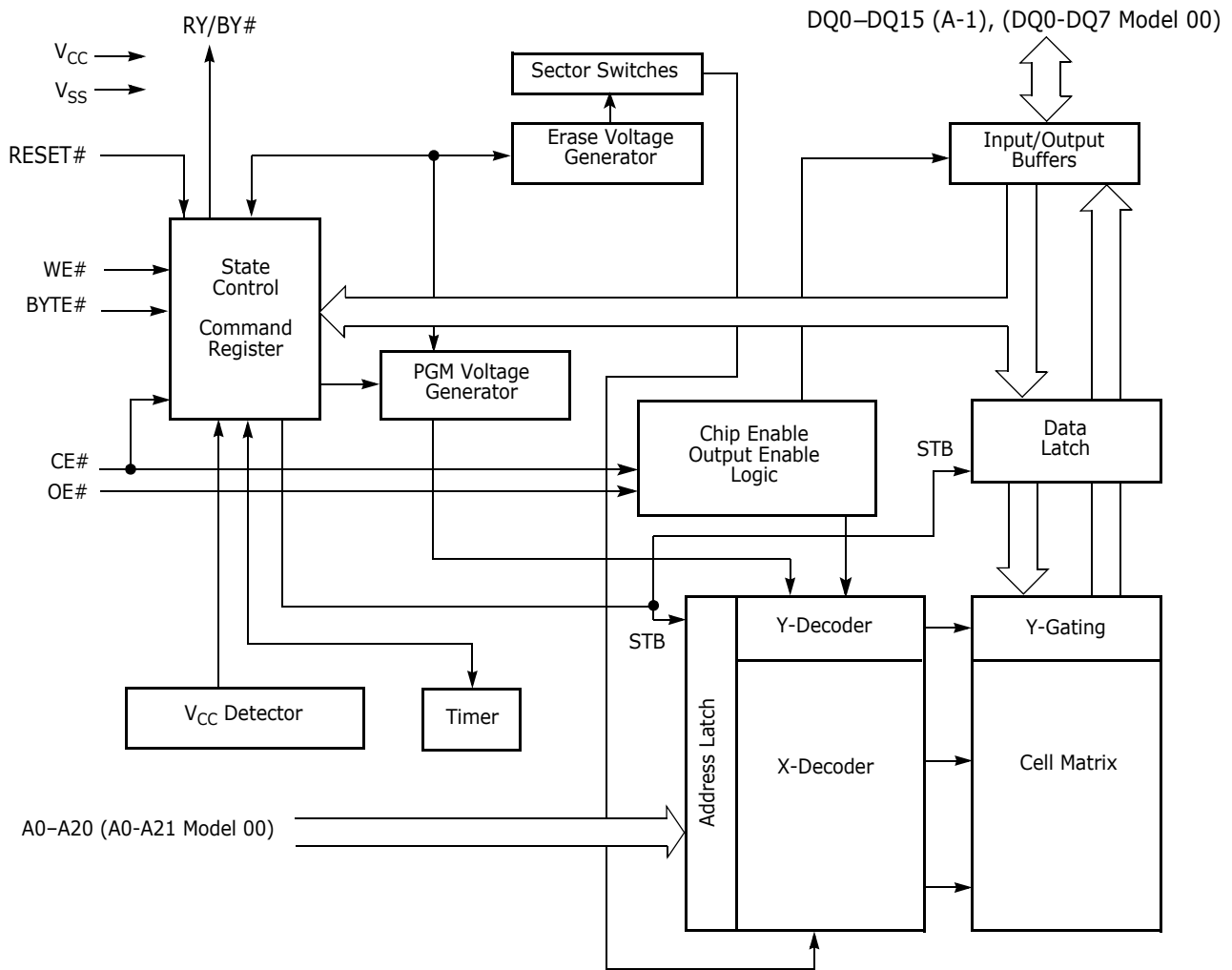

Connection Diagrams

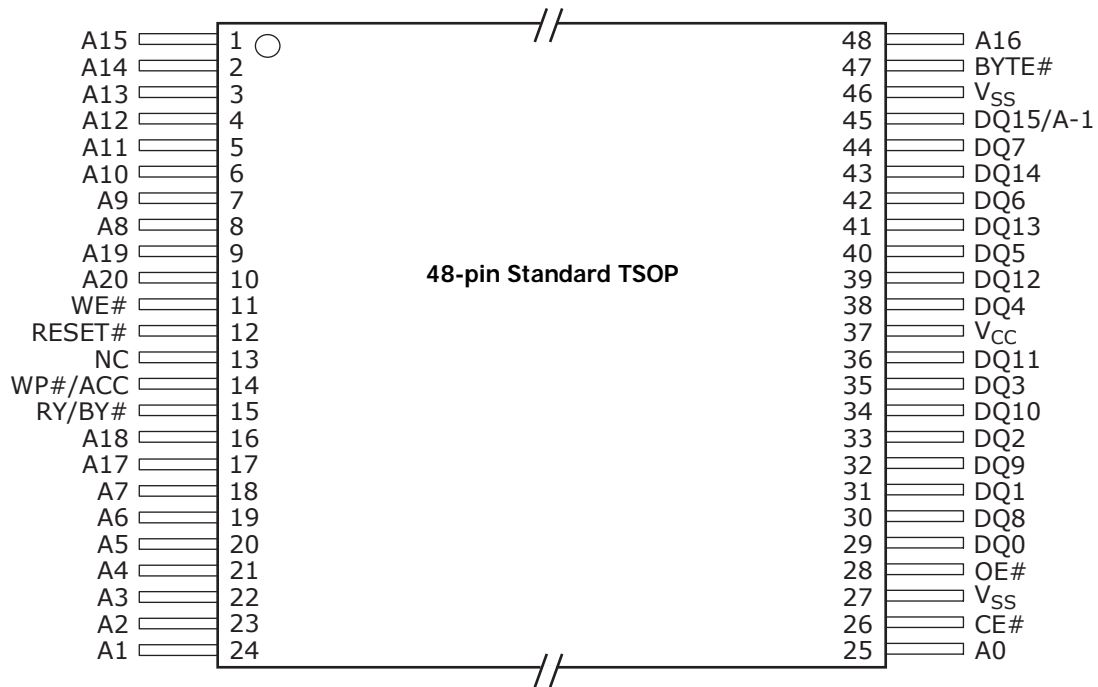
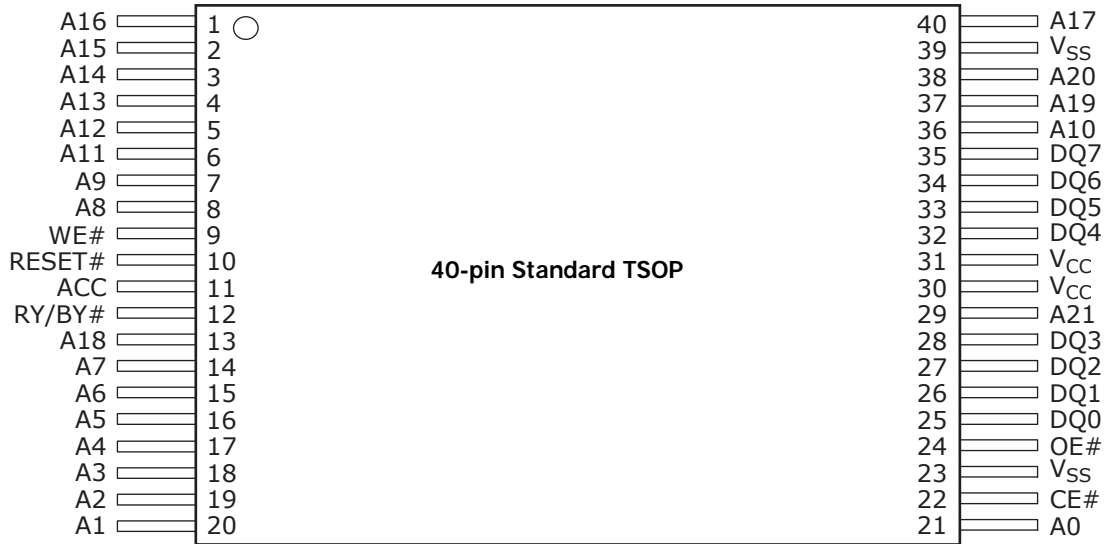

Connection Diagrams

For Model 00 Only

48-ball FBGA Top view balls facing down

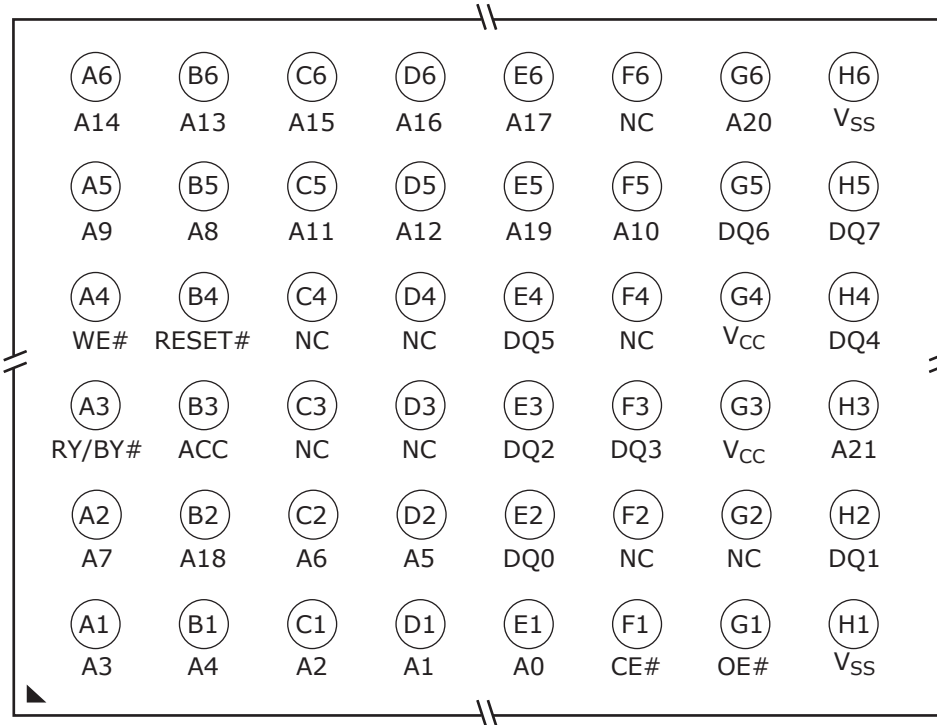

For Models 03, 04 Only

48-ball FBGA Top view balls facing down

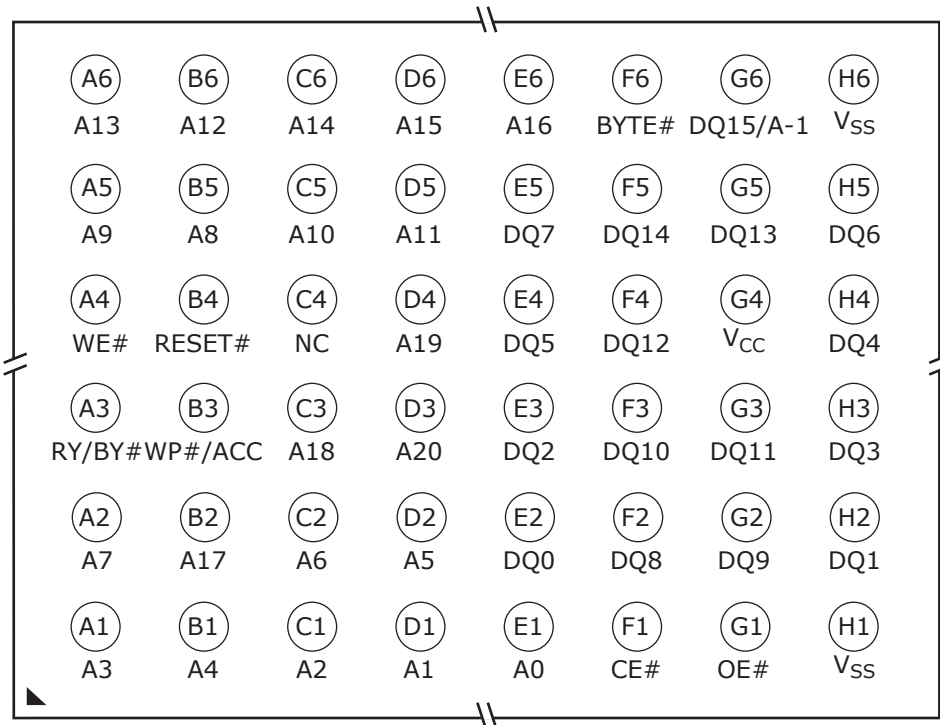

Special Handling Instructions

Special handling is required for Flash Memory products in FBGA packages.

Flash memory devices in FBGA packages may be damaged if exposed to ultrasonic cleaning methods. The package and/or data integrity may be compromised if the package body is exposed to temperatures above 150°C for prolonged periods of time.

Pin Configuration

A0-A21	=	22 address inputs
A0-A20	=	21 address inputs
DQ0-DQ7	=	8 data inputs/outputs
DQ0-DQ14	=	15 data inputs/outputs
DQ15/A-1	=	DQ15 (data input/output, word mode), A-1 (LSB address input, byte mode)
BYTE#	=	Selects 8-bit or 16-bit mode
CE#	=	Chip enable
OE#	=	Output enable
WE#	=	Write enable
RESET#	=	Hardware reset pin
WP#/ACC	=	Hardware Write Protect input/Programming Acceleration input.
ACC	=	Hardware Write Protect input
RY/BY#	=	Ready/Busy output
V _{CC}	=	3.0 volt-only single power supply see Product Selector Guide on page 5 for speed options and voltage supply tolerances)
V _{SS}	=	Device ground
NC	=	Pin not connected internally

Logic Symbol

Model 00

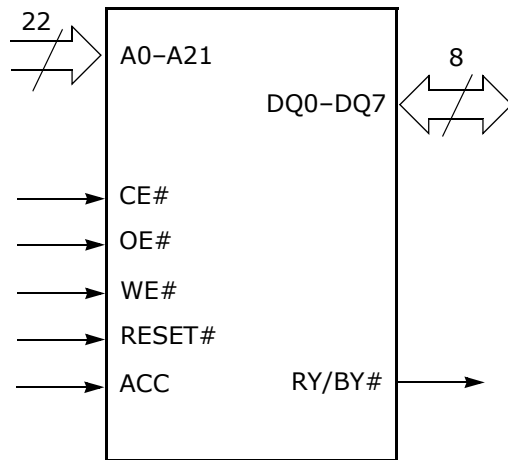

Models 03, 04

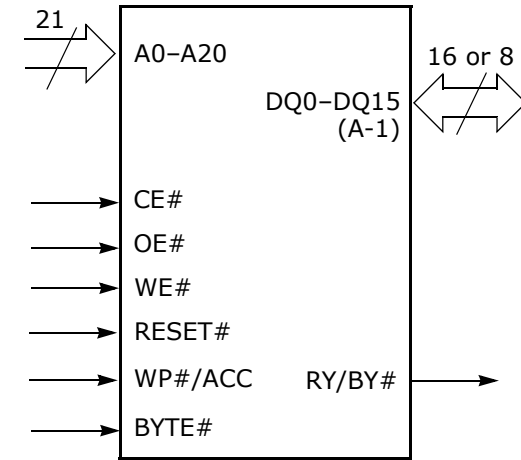

Ordering Information

S29AL032D Standard Products

Spansion standard products are available in several packages and operating ranges. The order number (Valid Combination) is formed by a combination of the elements below.

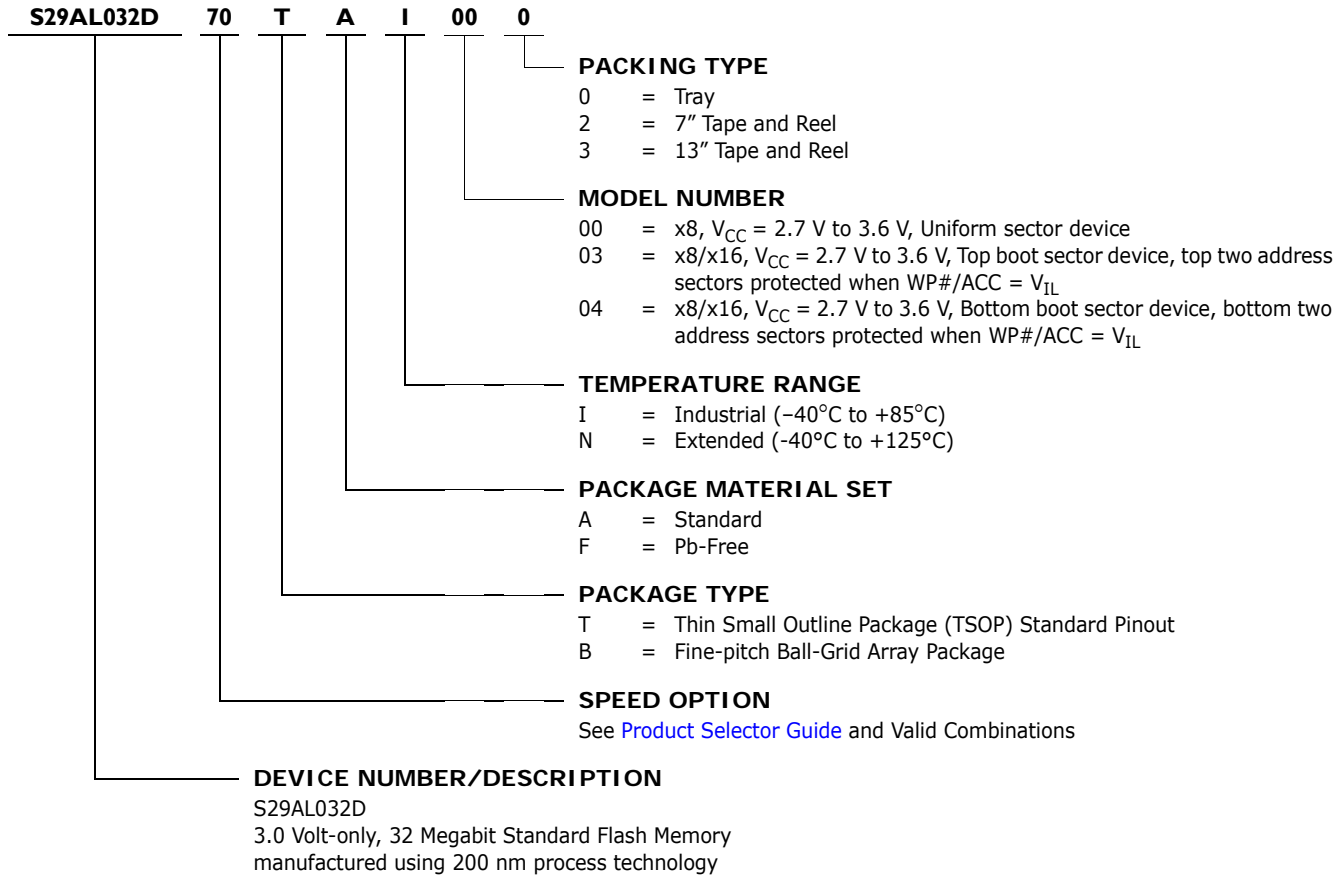

S29AL032D Valid Combinations					Package Description	
Device Number	Speed Option	Package Type, Material, and Temperature Range	Model Number	Packing Type		
S29AL032D	70	TAI, TFI	00	0, 3 (Note 1)	TS040 (Note 2)	TSOP
		BAI, BFI	00, 03, 04	0, 2, 3 (Note 1)	VBN048 (Note 3)	Fine-Pitch BGA
	90	TAI, TFI, TAN, TFN	03, 04	0, 3 (Note 1)	TS048 (Note 2)	TSOP
		BAI, BFI, BAN, BFN	00, 03, 04	0, 2, 3 (Note 1)	VBN048 (Note 3)	Fine-Pitch BGA

Notes:

- Type 0 is standard. Specify other options as required.
- TSOP package marking omits packing type designator from ordering part number.
- BGA package marking omits leading S29 and packing type designator from ordering part number.

Valid Combinations

Valid Combinations list configurations planned to be supported in volume for this device. Consult your local sales office to confirm availability of specific valid combinations and to check on newly released combinations.

Device Bus Operations

This section describes the requirements and use of the device bus operations, which are initiated through the internal command register. The command register itself does not occupy any addressable memory location. The register is composed of latches that store the commands, along with the address and data information needed to execute the command. The contents of the register serve as inputs to the internal state machine. The state machine outputs dictate the function of the device. Table 1 lists the device bus operations, the inputs and control levels they require, and the resulting output. The following subsections describe each of these operations in further detail.

Table 1. S29AL032D Device Bus Operations

Operation	CE#	OE#	WE#	RESET#	WP#(Note 6)/ ACC	Addresses (Note 3)	DQ0– DQ7	DQ8–DQ15 (Note 6)	
								BYTE# = V _{IH}	BYTE# = V _{IL}
Read	L	L	H	H	L/H	A _{IN}	D _{OUT}	D _{OUT}	DQ8–DQ14 = High-Z, DQ15 = A-1
Write (Note 1)	L	H	L	H	(Note 4)	A _{IN}	(Note 5)	(Note 5)	
Accelerated Program (Note 6)	L	H	L	H	V _{HH}	A _{IN}	(Note 5)	(Note 5)	
Standby	V _{CC} ± 0.3 V	X	X	V _{CC} ± 0.3 V	H	X	High-Z	High-Z	High-Z
Output Disable	L	H	H	H	L/H	X	High-Z	High-Z	High-Z
Reset	X	X	X	L	L/H	X	High-Z	High-Z	High-Z
Sector Protect (Note 3)	L	H	L	V _{ID}	L/H	SA, A6 = L, A1 = H, A0 = L	(Note 5)	X	X
Sector Unprotect (Note 3)	L	H	L	V _{ID}	(Note 4)	SA, A6 = H, A1 = H, A0 = L	(Note 5)	X	X
Temporary Sector Unprotect	X	X	X	V _{ID}	(Note 4)	A _{IN}	(Note 5)	(Note 5)	High-Z

Legend:

L = Logic Low = V_{IL}, H = Logic High = V_{IH}, V_{ID} = 12.0 ± 0.5 V, X = Don't Care, A_{IN} = Address In, D_{IN} = Data In, D_{OUT} = Data Out

Notes:

- When the ACC pin is at V_{HH}, the device enters the accelerated program mode. See
- Addresses are A20:A0 in word mode (BYTE# = V_{IH}), A20:A-1 in byte mode (BYTE# = V_{IL}).
- The sector protect and sector unprotect functions may also be implemented via programming equipment.
- If WP#/ACC = V_{IL}, the two outermost boot sectors remain protected. If WP#/ACC = V_{IH}, the two outermost boot sector protection depends on whether they were last protected or unprotected. If WP#/ACC = V_{HH}, all sectors are unprotected.
- D_{IN} or D_{OUT} as required by command sequence, data polling, or sector protection algorithm.
- Models 03, 04 only

Word/Byte Configuration (Models 03, 04 Only)

The BYTE# pin controls whether the device data I/O pins DQ15–DQ0 operate in the byte or word configuration. If the BYTE# pin is set at logic 1, the device is in word configuration, DQ15–DQ0 are active and controlled by CE# and OE#.

If the BYTE# pin is set at logic 0, the device is in byte configuration, and only data I/O pins DQ0–DQ7 are active and controlled by CE# and OE#. The data I/O pins DQ8–DQ14 are tri-stated, and the DQ15 pin is used as an input for the LSB (A-1) address function.

Requirements for Reading Array Data

To read array data from the outputs, the system must drive the CE# and OE# pins to V_{IL}. CE# is the power control and selects the device. OE# is the output control and gates array data to the output pins. WE# should remain at V_{IH}. The BYTE# pin determines whether the device outputs array data in words or bytes.

The internal state machine is set for reading array data upon device power-up, or after a hardware reset. This ensures that no spurious alteration of the memory content occurs during the power transition. No command is necessary in this mode to obtain array data. Standard microprocessor read cycles that assert valid addresses on the device-address inputs produce valid data on the device-data outputs. The device remains enabled for read access until the command register contents are altered.

See [Reading Array Data on page 31](#) for more information. Refer to the AC [Read Operations on page 49](#) table for timing specifications and to [Figure 14 on page 49](#) for the timing diagram. I_{CC1} in the DC Characteristics table represents the active current specification for reading array data.

Writing Commands/Command Sequences

To write a command or command sequence (which includes programming data to the device and erasing sectors of memory), the system must drive $WE\#$ and $CE\#$ to V_{IL} , and $OE\#$ to V_{IH} .

For program operations, the $BYTE\#$ pin determines whether the device accepts program data in bytes or words. Refer to [Word/Byte Configuration \(Models 03, 04 Only\) on page 11](#) for more information.

The device features an **Unlock Bypass** mode to facilitate faster programming. Once the device enters the Unlock Bypass mode, only two write cycles are required to program a word or byte, instead of four. [Word/Byte Program Command Sequence on page 32](#) has details on programming data to the device using both standard and Unlock Bypass command sequences.

An erase operation can erase one sector, multiple sectors, or the entire device. [Table 2 on page 14](#) and [Table 4 on page 16](#) indicate the address space that each sector occupies. A *sector address* consists of the address bits required to uniquely select a sector. The [Command Definitions on page 30](#) contains details on erasing a sector or the entire chip, or suspending/resuming the erase operation.

After the system writes the autoselect command sequence, the device enters the autoselect mode. The system can then read autoselect codes from the internal register (which is separate from the memory array) on $DQ7-DQ0$. Standard read cycle timings apply in this mode. Refer to [Autoselect Mode on page 20](#) and [Autoselect Command Sequence on page 31](#) for more information.

I_{CC2} in the DC Characteristics table represents the active current specification for the write mode. [AC Characteristics on page 49](#) contains timing specification tables and timing diagrams for write operations.

Program and Erase Operation Status

During an erase or program operation, the system may check the status of the operation by reading the status bits on $DQ7-DQ0$. Standard read cycle timings and I_{CC} read specifications apply. Refer to [Write Operation Status on page 38](#) for more information, and to [AC Characteristics on page 49](#) for timing diagrams.

Accelerated Program Operation

The device offers accelerated program operations through the ACC function. This is one of two functions provided by the $WP\#/ACC$ (ACC on Model 00) pin. This function is primarily intended to allow faster manufacturing throughput at the factory.

If the system asserts V_{HH} on this pin, the device automatically enters the previously mentioned Unlock Bypass mode, temporarily unprotects any protected sectors, and uses the higher voltage on the pin to reduce the time required for program operations. The system would use a two-cycle program command sequence as required by the Unlock Bypass mode. Removing V_{HH} from the $WP\#/ACC$ pin returns the device to normal operation. Note that the $WP\#/ACC$ pin must not be at V_{HH} for operations other than accelerated programming, or device damage may result. In addi-

tion, the WP#/ACC pin must not be left floating or unconnected; inconsistent behavior of the device may result.

Standby Mode

When the system is not reading or writing to the device, it can place the device in the standby mode. In this mode, current consumption is greatly reduced, and the outputs are placed in the high impedance state, independent of the OE# input.

The device enters the CMOS standby mode when the CE# and RESET# pins are both held at $V_{CC} \pm 0.3$ V. (Note that this is a more restricted voltage range than V_{IH} .) If CE# and RESET# are held at V_{IH} , but not within $V_{CC} \pm 0.3$ V, the device will be in the standby mode, but the standby current will be greater. The device requires standard access time (t_{CE}) for read access when the device is in either of these standby modes, before it is ready to read data.

If the device is deselected during erasure or programming, the device draws active current until the operation is completed.

In the [DC Characteristics](#) table, I_{CC3} and I_{CC4} represents the standby current specification.

Automatic Sleep Mode

The automatic sleep mode minimizes Flash device energy consumption. The device automatically enables this mode when addresses remain stable for $t_{ACC} + 30$ ns. The automatic sleep mode is independent of the CE#, WE#, and OE# control signals. Standard address access timings provide new data when addresses are changed. While in sleep mode, output data is latched and always available to the system. I_{CC4} in [DC Characteristics on page 45](#) represents the automatic sleep mode current specification.

RESET#: Hardware Reset Pin

The RESET# pin provides a hardware method of resetting the device to reading array data. When the system drives the RESET# pin to V_{IL} for at least a period of t_{RP} , the device **immediately terminates** any operation in progress, tristates all data output pins, and ignores all read/write attempts for the duration of the RESET# pulse. The device also resets the internal state machine to reading array data. The operation that was interrupted should be reinitiated once the device is ready to accept another command sequence, to ensure data integrity.

Current is reduced for the duration of the RESET# pulse. When RESET# is held at $V_{SS} \pm 0.3$ V, the device draws CMOS standby current (I_{CC4}). If RESET# is held at V_{IL} but not within $V_{SS} \pm 0.3$ V, the standby current will be greater.

The RESET# pin may be tied to the system reset circuitry. A system reset would thus also reset the Flash memory, enabling the system to read the boot-up firmware from the Flash memory.

If RESET# is asserted during a program or erase operation, the RY/BY# pin remains a 0 (busy) until the internal reset operation is complete, which requires a time of t_{READY} (during Embedded Algorithms). The system can thus monitor RY/BY# to determine whether the reset operation is complete. If RESET# is asserted when a program or erase operation is not executing (RY/BY# pin is 1), the reset operation is completed within a time of t_{READY} (not during Embedded Algorithms). The system can read data t_{RH} after the RESET# pin returns to V_{IH} .

Refer to [AC Characteristics on page 49](#) for RESET# parameters and to [Figure 15 on page 50](#) for the timing diagram.

Output Disable Mode

When the OE# input is at V_{IH} , output from the device is disabled. The output pins are placed in the high impedance state.

Table 2. Model 00 Sector Addresses (Sheet 1 of 2)

Sector	A21	A20	A19	A18	A17	A16	Address Range (in hexadecimal)
SA0	0	0	0	0	0	0	000000–00FFFF
SA1	0	0	0	0	0	1	010000–01FFFF
SA2	0	0	0	0	1	0	020000–02FFFF
SA3	0	0	0	0	1	1	030000–03FFFF
SA4	0	0	0	1	0	0	040000–04FFFF
SA5	0	0	0	1	0	1	050000–05FFFF
SA6	0	0	0	1	1	0	060000–06FFFF
SA7	0	0	0	1	1	1	070000–07FFFF
SA8	0	0	1	0	0	0	080000–08FFFF
SA9	0	0	1	0	0	1	090000–09FFFF
SA10	0	0	1	0	1	0	0A0000–0AFFFF
SA11	0	0	1	0	1	1	0B0000–0BFFFF
SA12	0	0	1	1	0	0	0C0000–0CFFFF
SA13	0	0	1	1	0	1	0D0000–0DFFFF
SA14	0	0	1	1	1	0	0E0000–0EFFFF
SA15	0	0	1	1	1	1	0F0000–0FFFFF
SA16	0	1	0	0	0	0	100000–10FFFF
SA17	0	1	0	0	0	1	110000–11FFFF
SA18	0	1	0	0	1	0	120000–12FFFF
SA19	0	1	0	0	1	1	130000–13FFFF
SA20	0	1	0	1	0	0	140000–14FFFF
SA21	0	1	0	1	0	1	150000–15FFFF
SA22	0	1	0	1	1	0	160000–16FFFF
SA23	0	1	0	1	1	1	170000–17FFFF
SA24	0	1	1	0	0	0	180000–18FFFF
SA25	0	1	1	0	0	1	190000–19FFFF
SA26	0	1	1	0	1	0	1A0000–1AFFFF
SA27	0	1	1	0	1	1	1B0000–1BFFFF
SA28	0	1	1	1	0	0	1C0000–1CFFFF
SA29	0	1	1	1	0	1	1D0000–1DFFFF
SA30	0	1	1	1	1	0	1E0000–1EFFFF
SA31	0	1	1	1	1	1	1F0000–1FFFFF
SA32	1	0	0	0	0	0	200000–20FFFF
SA33	1	0	0	0	0	1	210000–21FFFF
SA34	1	0	0	0	1	0	220000–22FFFF
SA35	1	0	0	0	1	1	230000–23FFFF
SA36	1	0	0	1	0	0	240000–24FFFF
SA37	1	0	0	1	0	1	250000–25FFFF

Table 2. Model 00 Sector Addresses (Sheet 2 of 2)

Sector	A21	A20	A19	A18	A17	A16	Address Range (in hexadecimal)
SA38	1	0	0	1	1	0	260000–26FFFF
SA39	1	0	0	1	1	1	270000–27FFFF
SA40	1	0	1	0	0	0	280000–28FFFF
SA41	1	0	1	0	0	1	290000–29FFFF
SA42	1	0	1	0	1	0	2A0000–2AFFFF
SA43	1	0	1	0	1	1	2B0000–2BFFFF
SA44	1	0	1	1	0	0	2C0000–2CFFFF
SA45	1	0	1	1	0	1	2D0000–2DFFFF
SA46	1	0	1	1	1	0	2E0000–2EFFFF
SA47	1	0	1	1	1	1	2F0000–2FFFFF
SA48	1	1	0	0	0	0	300000–30FFFF
SA49	1	1	0	0	0	1	310000–31FFFF
SA50	1	1	0	0	1	0	320000–32FFFF
SA51	1	1	0	0	1	1	330000–33FFFF
SA52	1	1	0	1	0	0	340000–34FFFF
SA53	1	1	0	1	0	1	350000–35FFFF
SA54	1	1	0	1	1	0	360000–36FFFF
SA55	1	1	0	1	1	1	370000–37FFFF
SA56	1	1	1	0	0	0	380000–38FFFF
SA57	1	1	1	0	0	1	390000–39FFFF
SA58	1	1	1	0	1	0	3A0000–3AFFFF
SA59	1	1	1	0	1	1	3B0000–3BFFFF
SA60	1	1	1	1	0	0	3C0000–3CFFFF
SA61	1	1	1	1	0	1	3D0000–3DFFFF
SA62	1	1	1	1	1	0	3E0000–3EFFFF
SA63	1	1	1	1	1	1	3F0000–3FFFFF

Notes:

1. All sectors are 64 Kbytes in size.

Table 3. Model 00 Secured Silicon Sector Addresses

Sector Address A21–A7	Sector Size (bytes)	(x8) Address Range
0000000000000000	128	000000h–00007fh
0000000000001000	128	000400h–00047fh

Table 4. Model 03 Sector Addresses (Sheet 1 of 2)

Sector	Sector Address A20–A12	Sector Size (Kbytes/Kwords)	(x8) Address Range	(x16) Address Range
SA0	000000xxx	64/32	000000h–00FFFFh	000000h–07FFFh
SA1	000001xxx	64/32	010000h–01FFFFh	008000h–0FFFFh
SA2	000010xxx	64/32	020000h–02FFFFh	010000h–17FFFh
SA3	000011xxx	64/32	030000h–03FFFFh	018000h–01FFFFh
SA4	000100xxx	64/32	040000h–04FFFFh	020000h–027FFFh
SA5	000101xxx	64/32	050000h–05FFFFh	028000h–02FFFFh
SA6	000110xxx	64/32	060000h–06FFFFh	030000h–037FFFh
SA7	000111xxx	64/32	070000h–07FFFFh	038000h–03FFFFh
SA8	001000xxx	64/32	080000h–08FFFFh	040000h–047FFFh
SA9	001001xxx	64/32	090000h–09FFFFh	048000h–04FFFFh
SA10	001010xxx	64/32	0A0000h–0AFFFFh	050000h–057FFFh
SA11	001011xxx	64/32	0B0000h–0BFFFFh	058000h–05FFFFh
SA12	001100xxx	64/32	0C0000h–0CFFFFh	060000h–067FFFh
SA13	001101xxx	64/32	0D0000h–0DFFFFh	068000h–06FFFFh
SA14	001110xxx	64/32	0E0000h–0EFFFFh	070000h–077FFFh
SA15	001111xxx	64/32	0F0000h–0FFFFh	078000h–07FFFFh
SA16	010000xxx	64/32	100000h–10FFFFh	080000h–087FFFh
SA17	010001xxx	64/32	110000h–11FFFFh	088000h–08FFFFh
SA18	010010xxx	64/32	120000h–12FFFFh	090000h–097FFFh
SA19	010011xxx	64/32	130000h–13FFFFh	098000h–09FFFFh
SA20	010100xxx	64/32	140000h–14FFFFh	0A0000h–0A7FFFh
SA21	010101xxx	64/32	150000h–15FFFFh	0A8000h–0AFFFFh
SA22	010110xxx	64/32	160000h–16FFFFh	0B0000h–0B7FFFh
SA23	010111xxx	64/32	170000h–17FFFFh	0B8000h–0BFFFFh
SA24	011000xxx	64/32	180000h–18FFFFh	0C0000h–0C7FFFh
SA25	011001xxx	64/32	190000h–19FFFFh	0C8000h–0CFFFFh
SA26	011010xxx	64/32	1A0000h–1AFFFFh	0D0000h–0D7FFFh
SA27	011011xxx	64/32	1B0000h–1BFFFFh	0D8000h–0DFFFFh
SA28	011100xxx	64/32	1C0000h–1CFFFFh	0E0000h–0E7FFFh
SA29	011101xxx	64/32	1D0000h–1DFFFFh	0E8000h–0EFFFFh
SA30	011110xxx	64/32	1E0000h–1EFFFFh	0F0000h–0F7FFFh
SA31	011111xxx	64/32	1F0000h–1FFFFh	0F8000h–0FFFFh
SA32	100000xxx	64/32	200000h–20FFFFh	100000h–107FFFh
SA33	100001xxx	64/32	210000h–21FFFFh	108000h–10FFFFh
SA34	100010xxx	64/32	220000h–22FFFFh	110000h–117FFFh
SA35	100011xxx	64/32	230000h–23FFFFh	118000h–11FFFFh
SA36	100100xxx	64/32	240000h–24FFFFh	120000h–127FFFh
SA37	100101xxx	64/32	250000h–25FFFFh	128000h–12FFFFh
SA38	100110xxx	64/32	260000h–26FFFFh	130000h–137FFFh

Table 4. Model 03 Sector Addresses (Sheet 2 of 2)

Sector	Sector Address A20–A12	Sector Size (Kbytes/Kwords)	(x8) Address Range	(x16) Address Range
SA39	10011xxx	64/32	270000h–27FFFFh	138000h–13FFFFh
SA40	101000xxx	64/32	280000h–28FFFFh	140000h–147FFFh
SA41	101001xxx	64/32	290000h–29FFFFh	148000h–14FFFFh
SA42	101010xxx	64/32	2A0000h–2AFFFFh	150000h–157FFFh
SA43	101011xxx	64/32	2B0000h–2BFFFFh	158000h–15FFFFh
SA44	101100xxx	64/32	2C0000h–2CFFFFh	160000h–167FFFh
SA45	101101xxx	64/32	2D0000h–2DFFFFh	168000h–16FFFFh
SA46	101110xxx	64/32	2E0000h–2EFFFFh	170000h–177FFFh
SA47	101111xxx	64/32	2F0000h–2FFFFFh	178000h–17FFFFh
SA48	110000xxx	64/32	300000h–30FFFFh	180000h–187FFFh
SA49	110001xxx	64/32	310000h–31FFFFh	188000h–18FFFFh
SA50	110010xxx	64/32	320000h–32FFFFh	190000h–197FFFh
SA51	110011xxx	64/32	330000h–33FFFFh	198000h–19FFFFh
SA52	110100xxx	64/32	340000h–34FFFFh	1A0000h–1A7FFFh
SA53	110101xxx	64/32	350000h–35FFFFh	1A8000h–1AFFFFh
SA54	110110xxx	64/32	360000h–36FFFFh	1B0000h–1B7FFFh
SA55	110111xxx	64/32	370000h–37FFFFh	1B8000h–1BFFFFh
SA56	111000xxx	64/32	380000h–38FFFFh	1C0000h–1C7FFFh
SA57	111001xxx	64/32	390000h–39FFFFh	1C8000h–1CFFFFh
SA58	111010xxx	64/32	3A0000h–3AFFFFh	1D0000h–1D7FFFh
SA59	111011xxx	64/32	3B0000h–3BFFFFh	1D8000h–1DFFFFh
SA60	111100xxx	64/32	3C0000h–3CFFFFh	1E0000h–1E7FFFh
SA61	111101xxx	64/32	3D0000h–3DFFFFh	1E8000h–1EFFFFh
SA62	111110xxx	64/32	3E0000h–3EFFFFh	1F0000h–1F7FFFh
SA63	111111000	8/4	3F0000h–3F1FFFh	1F8000h–1F8FFFh
SA64	111111001	8/4	3F2000h–3F3FFFh	1F9000h–1F9FFFh
SA65	111111010	8/4	3F4000h–3F5FFFh	1FA000h–1FAFFFh
SA66	111111011	8/4	3F6000h–3F7FFFh	1FB000h–1FBFFFh
SA67	111111100	8/4	3F8000h–3F9FFFh	1FC000h–1FCFFFh
SA68	111111101	8/4	3FA000h–3FBFFFh	1FD000h–1FDFFFh
SA69	111111110	8/4	3FC000h–3FDFFFh	1FE000h–1FEFFFh
SA70	111111111	8/4	3FE000h–3FFFFFh	1FF000h–1FFFFFh

Note: The address range is A20:A-1 in byte mode (BYTE#=V_{IL}) or A20:A0 in word mode (BYTE#=V_{IH}).

Table 5. Model 03 Secured Silicon Sector Addresses

Sector Address A20–A12	Sector Size (bytes/words)	(x8) Address Range	(x16) Address Range
111111111	256/128	3FFF00h–3FFFFFh	1FFF80h–1FFFFFh

Table 6. Model 04 Sector Addresses (Sheet 1 of 2)

Sector	Sector Address A20–A12	Sector Size (Kbytes/Kwords)	(x8) Address Range	(x16) Address Range
SA0	000000000	8/4	000000h-001FFFh	000000h-000FFFh
SA1	000000001	8/4	002000h-003FFFh	001000h-001FFFh
SA2	000000010	8/4	004000h-005FFFh	002000h-002FFFh
SA3	000000011	8/4	006000h-007FFFh	003000h-003FFFh
SA4	000000100	8/4	008000h-009FFFh	004000h-004FFFh
SA5	000000101	8/4	00A000h-00BFFFh	005000h-005FFFh
SA6	000000110	8/4	00C000h-00DFFFh	006000h-006FFFh
SA7	000000111	8/4	00E000h-00FFFFh	007000h-007FFFh
SA8	000001xxx	64/32	010000h-01FFFh	008000h-00FFFFh
SA9	000010xxx	64/32	020000h-02FFFh	010000h-017FFFh
SA10	000011xxx	64/32	030000h-03FFFh	018000h-01FFFFh
SA11	000100xxx	64/32	040000h-04FFFh	020000h-027FFFh
SA12	000101xxx	64/32	050000h-05FFFh	028000h-02FFFFh
SA13	000110xxx	64/32	060000h-06FFFh	030000h-037FFFh
SA14	000111xxx	64/32	070000h-07FFFh	038000h-03FFFFh
SA15	001000xxx	64/32	080000h-08FFFh	040000h-047FFFh
SA16	001001xxx	64/32	090000h-09FFFh	048000h-04FFFFh
SA17	001010xxx	64/32	0A0000h-0AFFFh	050000h-057FFFh
SA18	001011xxx	64/32	0B0000h-0BFFFh	058000h-05FFFFh
SA19	001100xxx	64/32	0C0000h-0CFFFh	060000h-067FFFh
SA20	001101xxx	64/32	0D0000h-0DFFFh	068000h-06FFFFh
SA21	001110xxx	64/32	0E0000h-0EFFFh	070000h-077FFFh
SA22	001111xxx	64/32	0F0000h-0FFFFh	078000h-07FFFFh
SA23	010000xxx	64/32	100000h-10FFFh	080000h-087FFFh
SA24	010001xxx	64/32	110000h-11FFFh	088000h-08FFFFh
SA25	010010xxx	64/32	120000h-12FFFh	090000h-097FFFh
SA26	010011xxx	64/32	130000h-13FFFh	098000h-09FFFFh
SA27	010100xxx	64/32	140000h-14FFFh	0A0000h-0A7FFFh
SA28	010101xxx	64/32	150000h-15FFFh	0A8000h-0AFFFFh
SA29	010110xxx	64/32	160000h-16FFFh	0B0000h-0B7FFFh
SA30	010111xxx	64/32	170000h-17FFFh	0B8000h-0BFFFFh
SA31	011000xxx	64/32	180000h-18FFFh	0C0000h-0C7FFFh
SA32	011001xxx	64/32	190000h-19FFFh	0C8000h-0CFFFFh
SA33	011010xxx	64/32	1A0000h-1AFFFh	0D0000h-0D7FFFh
SA34	011011xxx	64/32	1B0000h-1BFFFh	0D8000h-0DFFFFh
SA35	011100xxx	64/32	1C0000h-1CFFFh	0E0000h-0E7FFFh
SA36	011101xxx	64/32	1D0000h-1DFFFh	0E8000h-0EFFFFh
SA37	011110xxx	64/32	1E0000h-1EFFFh	0F0000h-0F7FFFh
SA38	011111xxx	64/32	1F0000h-1FFFFh	0F8000h-0FFFFh

Table 6. Model 04 Sector Addresses (Sheet 2 of 2)

Sector	Sector Address A20–A12	Sector Size (Kbytes/Kwords)	(x8) Address Range	(x16) Address Range
SA39	100000xxx	64/32	200000h–20FFFFh	100000h–107FFFh
SA40	100001xxx	64/32	210000h–21FFFFh	108000h–10FFFFh
SA41	100010xxx	64/32	220000h–22FFFFh	110000h–117FFFh
SA42	100011xxx	64/32	230000h–23FFFFh	118000h–11FFFFh
SA43	100100xxx	64/32	240000h–24FFFFh	120000h–127FFFh
SA44	100101xxx	64/32	250000h–25FFFFh	128000h–12FFFFh
SA45	100110xxx	64/32	260000h–26FFFFh	130000h–137FFFh
SA46	100111xxx	64/32	270000h–27FFFFh	138000h–13FFFFh
SA47	101000xxx	64/32	280000h–28FFFFh	140000h–147FFFh
SA48	101001xxx	64/32	290000h–29FFFFh	148000h–14FFFFh
SA49	101010xxx	64/32	2A0000h–2AFFFFh	150000h–157FFFh
SA50	101011xxx	64/32	2B0000h–2BFFFFh	158000h–15FFFFh
SA51	101100xxx	64/32	2C0000h–2CFFFFh	160000h–167FFFh
SA52	101101xxx	64/32	2D0000h–2DFFFFh	168000h–16FFFFh
SA53	101110xxx	64/32	2E0000h–2EFFFFh	170000h–177FFFh
SA54	101111xxx	64/32	2F0000h–2FFFFFh	178000h–17FFFFh
SA55	111000xxx	64/32	300000h–30FFFFh	180000h–187FFFh
SA56	110001xxx	64/32	310000h–31FFFFh	188000h–18FFFFh
SA57	110010xxx	64/32	320000h–32FFFFh	190000h–197FFFh
SA58	110011xxx	64/32	330000h–33FFFFh	198000h–19FFFFh
SA59	110100xxx	64/32	340000h–34FFFFh	1A0000h–1A7FFFh
SA60	110101xxx	64/32	350000h–35FFFFh	1A8000h–1AFFFFh
SA61	110110xxx	64/32	360000h–36FFFFh	1B0000h–1B7FFFh
SA62	110111xxx	64/32	370000h–37FFFFh	1B8000h–1BFFFFh
SA63	111000xxx	64/32	380000h–38FFFFh	1C0000h–1C7FFFh
SA64	111001xxx	64/32	390000h–39FFFFh	1C8000h–1CFFFFh
SA65	111010xxx	64/32	3A0000h–3AFFFFh	1D0000h–1D7FFFh
SA66	111011xxx	64/32	3B0000h–3BFFFFh	1D8000h–1DFFFFh
SA67	111100xxx	64/32	3C0000h–3CFFFFh	1E0000h–1E7FFFh
SA68	111101xxx	64/32	3D0000h–3DFFFFh	1E8000h–1EFFFFh
SA69	111110xxx	64/32	3E0000h–3EFFFFh	1F0000h–1F7FFFh
SA70	111111xxx	64/32	3F0000h–3FFFFFh	1F8000h–1FFFFFh

Note: The address range is A20:A-1 in byte mode (BYTE#=V_{IL}) or A20:A0 in word mode (BYTE#=V_{IH}).

Table 7. Model 04 Secured Silicon Sector Addresses

Sector Address A20–A12	Sector Size (bytes/words)	(x8) Address Range	(x16) Address Range
000000000	256/128	000000h–0000FFh	00000h–0007Fh

Autoselect Mode

The autoselect mode provides manufacturer and device identification, and sector protection verification, through identifier codes output on DQ7–DQ0. This mode is primarily intended for programming equipment to automatically match a device to be programmed with its corresponding programming algorithm. However, the autoselect codes can also be accessed in-system through the command register.

When using programming equipment, the autoselect mode requires V_{ID} (11.5 V to 12.5 V) on address pin A9. Address pins A6, A1, and A0 must be as shown in Table 8. In addition, when verifying sector protection, the sector address must appear on the appropriate highest order address bits (see Table 2 on page 14 and Table 4 on page 16). Table 8 shows the remaining address bits that are don't care. When all necessary bits have been set as required, the programming equipment may then read the corresponding identifier code on DQ7–DQ0.

To access the autoselect codes in-system, the host system can issue the autoselect command via the command register, as shown in Table 17 on page 37. This method does not require V_{ID} . See Command Definitions for details on using the autoselect mode.

Table 8. S29AL032D Autoselect Codes (High Voltage Method)

Description	Mode	CE#	OE#	WE#	A21 to A12	A11 to A10	A9	A8 to A7	A6	A5 to A4	A3 to A2	A1	A0	DQ8 to DQ15	DQ7 to DQ0
Manufacturer ID: Spansion		L	L	H	X	X	V_{ID}	X	L	X	L	L	L	X	01h
Device ID: S29AL032D (Model 00)	Byte	L	L	H	X	X	V_{ID}	X	L	X	L	L	H	N/A	A3h
Device ID: S29AL032D (Model 03)	Word	L	L	H	X	X	V_{ID}	X	L	X	L	L	H	22h	F6h
	Byte	L	L	H										X	F6h
Device ID: S29AL032D (Model 04)	Word	L	L	H	X	X	V_{ID}	X	L	X	L	L	H	22h	F9h
	Byte	L	L	H										X	F9h
Sector Protection Verification		L	L	H	SA	X	V_{ID}	X	L	X	L	H	L	X	01h (protected)
														X	00h (unprotected)
Secured Silicon Sector Indicator Bit (DQ7) (Model 00)		L	L	H	X	X	V_{ID}	X	L	X	L	H	H	X	85 (factory locked)
														X	05 (not factory locked)
Secured Silicon Sector Indicator Bit (DQ7) (Model 03)		L	L	H	X	X	V_{ID}	X	L	X	L	H	H	X	8D (factory locked)
														X	0D (not factory locked)
Secured Silicon Sector Indicator Bit (DQ7) (Model 04)		L	L	H	X	X	V_{ID}	X	L	X	L	H	H	X	9D (factory locked)
														X	1D (not factory locked)

L = Logic Low = V_{IL} , H = Logic High = V_{IH} , SA = Sector Address, X = Don't care.

Note: The autoselect codes may also be accessed in-system via command sequences. See Table 17 on page 37.

Sector Protection/Unprotection

The hardware sector protection feature disables both program and erase operations in any sector. The hardware sector unprotection feature re-enables both program and erase operations in previously protected sectors.

The device is shipped with all sectors unprotected. Spansion offers the option of programming and protecting sectors at its factory prior to shipping the device through the Spansion Express-Flash™ Service. Contact a Spansion representative for further details.

It is possible to determine whether a sector is protected or unprotected. See [Autoselect Mode](#) for details.

Sector protection/unprotection can be implemented via two methods.

The primary method requires V_{ID} on the RESET# pin only, and can be implemented either in-system or via programming equipment. [Figure 2 on page 25](#) shows the algorithms and [Figure 26 on page 58](#) shows the timing diagram. This method uses standard microprocessor bus cycle timing. For sector unprotect, all unprotected sectors must first be protected prior to the first sector unprotect write cycle.

The alternate method intended only for programming equipment requires V_{ID} on address pin A9 and OE#. This method is compatible with programmer routines written for earlier 3.0-volt-only Spansion flash devices. Details on this method are provided in a supplement, publication number 21468. Contact a Spansion representative to request a copy.

Table 9. Sector Block Addresses for Protection/Unprotection — Model 00

Sector/Sector Block	A21–A16	Sector/Sector Block Size
SA0	000000	64 Kbytes
SA1-SA3	000001,000010, 000011	192 (3x64) Kbytes
SA4-SA7	000100, 000101, 000110, 000111	256 (4x64) Kbytes
SA8-SA11	001000, 001001, 001010, 001011	256 (4x64) Kbytes
SA12-SA15	001100, 001101, 001110, 001111	256 (4x64) Kbytes
SA16-SA19	010000, 010001, 010010, 010011	256 (4x64) Kbytes
SA20-SA23	010100, 010101, 010110, 010111	256 (4x64) Kbytes
SA24-SA27	011000, 011001, 011010, 011011	256 (4x64) Kbytes
SA28-SA31	011100, 011101, 011110, 011111	256 (4x64) Kbytes
SA32-SA35	100000, 100001, 100010, 100011	256 (4x64) Kbytes
SA36-SA39	100100, 100101, 100110, 100111	256 (4x64) Kbytes
SA40-SA43	101000, 101001, 101010, 101011	256 (4x64) Kbytes
SA44-SA47	101100, 101101, 101110, 101111	256 (4x64) Kbytes
SA48-SA51	110000, 110001, 110010, 110011	256 (4x64) Kbytes
SA52-SA55	110100, 110101, 110110, 110111	256 (4x64) Kbytes
SA56-SA59	111000, 111001, 111010, 111011	256 (4x64) Kbytes
SA60-SA62	111100, 111101, 111110	192 (4x64) Kbytes
SA63	111111	64 Kbytes

Table I0. Sector Block Addresses for Protection/Unprotection — Model 03

Sector / Sector Block	A20–A12	Sector/Sector Block Size
SA0-SA3	000000XXX, 000001XXX, 000010XXX 000011XXX	256 (4x64) Kbytes
SA4-SA7	0001XXXXX	256 (4x64) Kbytes
SA8-SA11	0010XXXXX	256 (4x64) Kbytes
SA12-SA15	0011XXXXX	256 (4x64) Kbytes
SA16-SA19	0100XXXXX	256 (4x64) Kbytes
SA20-SA23	0101XXXXX	256 (4x64) Kbytes
SA24-SA27	0110XXXXX	256 (4x64) Kbytes
SA28-SA31	0111XXXXX	256 (4x64) Kbytes
SA32-SA35	1000XXXXX	256 (4x64) Kbytes
SA36-SA39	1001XXXXX	256 (4x64) Kbytes
SA40-SA43	1010XXXXX	256 (4x64) Kbytes
SA44-SA47	1011XXXXX	256 (4x64) Kbytes
SA48-SA51	1100XXXXX	256 (4x64) Kbytes
SA52-SA55	1101XXXXX	256 (4x64) Kbytes
SA56-SA59	1110XXXXX	256 (4x64) Kbytes
SA60-SA62	111100XXX, 111101XXX, 111110XXX	192 (3x64) Kbytes
SA63	111111000	8 Kbytes
SA64	111111001	8 Kbytes
SA65	111111010	8 Kbytes
SA66	111111011	8 Kbytes
SA67	111111100	8 Kbytes
SA68	111111101	8 Kbytes
SA69	111111110	8 Kbytes
SA70	111111111	8 Kbytes

Table II. Sector Block Addresses for Protection/Unprotection — Model 04

Sector / Sector Block	A20–A12	Sector/Sector Block Size
SA70-SA67	111111XXX, 111110XXX, 111101XXX, 111100XXX	256 (4x64) Kbytes
SA66-SA63	1110XXXXX	256 (4x64) Kbytes
SA62-SA59	1101XXXXX	256 (4x64) Kbytes
SA58-SA55	1100XXXXX	256 (4x64) Kbytes
SA54-SA51	1011XXXXX	256 (4x64) Kbytes
SA50-SA47	1010XXXXX	256 (4x64) Kbytes
SA46-SA43	1001XXXXX	256 (4x64) Kbytes
SA42-SA39	1000XXXXX	256 (4x64) Kbytes
SA38-SA35	0111XXXXX	256 (4x64) Kbytes
SA34-SA31	0110XXXXX	256 (4x64) Kbytes
SA30-SA27	0101XXXXX	256 (4x64) Kbytes
SA26-SA23	0100XXXXX	256 (4x64) Kbytes
SA22-SA19	0011XXXXX	256 (4x64) Kbytes
SA18-SA15	0010XXXXX	256 (4x64) Kbytes
SA14-SA11	0001XXXXX	256 (4x64) Kbytes
SA10-SA8	000011XXX, 000010XXX, 000001XXX	192 (3x64) Kbytes
SA7	000000111	8 Kbytes
SA6	000000110	8 Kbytes
SA5	000000101	8 Kbytes
SA4	000000100	8 Kbytes
SA3	000000011	8 Kbytes
SA2	000000010	8 Kbytes
SA1	000000001	8 Kbytes
SA0	000000000	8 Kbytes

Write Protect (WP#) — Models 03, 04 Only

The Write Protect function provides a hardware method of protecting certain boot sectors without using V_{ID} . This function is one of two provided by the WP#/ACC pin.

If the system asserts V_{IL} on the WP#/ACC pin, the device disables program and erase functions in the two *outermost* 8-Kbyte boot sectors independently of whether those sectors were protected or unprotected using the method described in [Sector Protection/Unprotection on page 20](#). The two outermost 8-Kbyte boot sectors are the two sectors containing the lowest addresses in a bottom-boot-configured device, or the two sectors containing the highest addresses in a top-boot-configured device.

If the system asserts V_{IH} on the WP#/ACC pin, the device reverts to whether the two outermost 8-Kbyte boot sectors were last set to be protected or unprotected. That is, sector protection or unprotection for these two sectors depends on whether they were last protected or unprotected using the method described in [Sector Protection/Unprotection on page 20](#).

Note that the WP#/ACC pin must not be left floating or unconnected; inconsistent behavior of the device may result.

Temporary Sector Unprotect

This feature allows temporary unprotection of previously protected sectors to change data in-system. The Sector Unprotect mode is activated by setting the RESET# pin to V_{ID} . During this mode, formerly protected sectors can be programmed or erased by selecting the sector addresses. Once V_{ID} is removed from the RESET# pin, all the previously protected sectors are protected again. shows the algorithm, and [Figure 24 on page 57](#) shows the timing diagrams, for this feature.

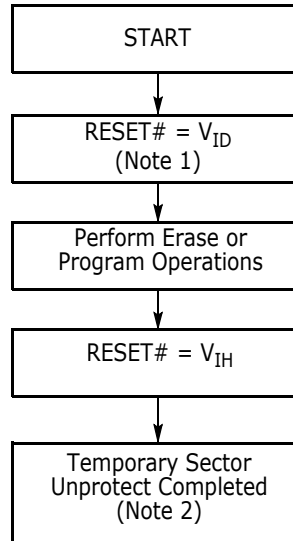

Notes:

1. All protected sectors unprotected.
2. All previously protected sectors are protected once again.

Figure 1. Temporary Sector Unprotect Operation

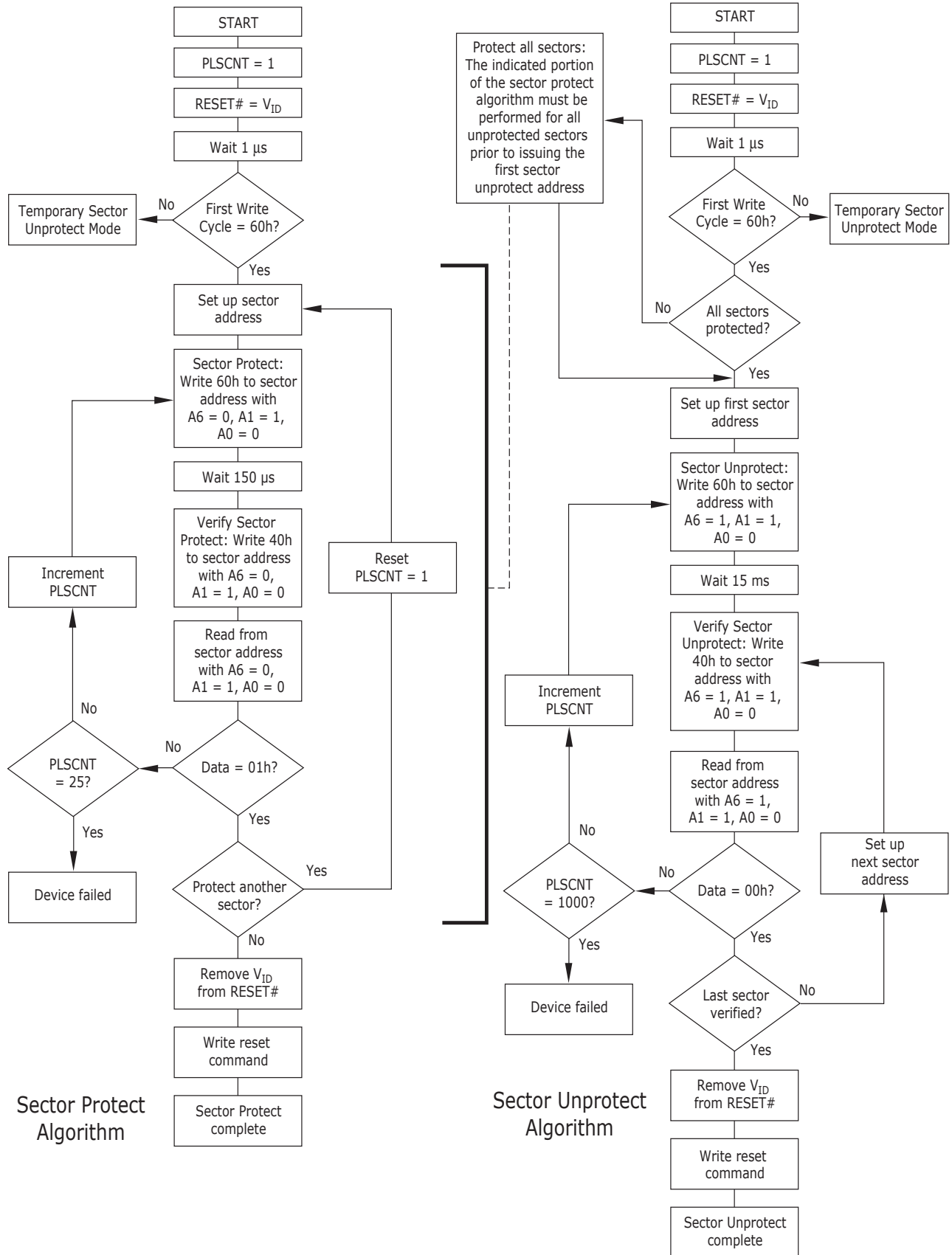

Figure 2. In-System Sector Protect/Unprotect Algorithms

Secured Silicon Sector Flash Memory Region

The Secured Silicon Sector feature provides a 256-byte Flash memory region that enables permanent part identification through an Electronic Serial Number (ESN). The Secured Silicon Sector uses a Secured Silicon Sector Indicator Bit (DQ7) to indicate whether or not the Secured Silicon Sector is locked when shipped from the factory. This bit is permanently set at the factory and cannot be changed, which prevents cloning of a factory-locked part. This ensures the security of the ESN once the product is shipped to the field.

Spansion offers the device with the Secured Silicon Sector either factory-locked or customer-lockable. The factory-locked version is always protected when shipped from the factory, and has the Secured Silicon Sector Indicator Bit permanently set to a 1. The customer-lockable version is shipped with the Secured Silicon Sector unprotected, allowing customers to utilize the that sector in any manner they choose. The customer-lockable version has the Secured Silicon Sector Indicator Bit permanently set to a 0. Thus, the Secured Silicon Sector Indicator Bit prevents customer-lockable devices from being used to replace devices that are factory locked.

The system accesses the Secured Silicon Sector through a command sequence (see [Enter Secured Silicon Sector/Exit Secured Silicon Sector Command Sequence on page 32](#)). After the system writes the Enter Secured Silicon Sector command sequence, it may read the Secured Silicon Sector by using the addresses normally occupied by the boot sectors. This mode of operation continues until the system issues the Exit Secured Silicon Sector command sequence, or until power is removed from the device. On power-up, or following a hardware reset, the device reverts to sending commands to the boot sectors.

Factory Locked: Secured Silicon Sector Programmed and Protected at the Factory

In a factory locked device, the Secured Silicon Sector is protected when the device is shipped from the factory. The Secured Silicon Sector cannot be modified in any way. The device is available pre-programmed with one of the following:

- A random, secure ESN only.
- Customer code through the ExpressFlash service.
- Both a random, secure ESN and customer code through the ExpressFlash service.

In devices that have an ESN, a Bottom Boot device has the 16-byte (8-word) ESN in sector 0 at addresses 00000h–0000Fh in byte mode (or 00000h–00007h in word mode). In the Top Boot device, the ESN is in sector 70 at addresses 3FFF00h–3FFF0Fh in byte mode (or 1FFF80h–1FFF87h in word mode). In the Uniform device, the ESN is in sector 63 at addresses 3FFF00h–3FFF0Fh in byte mode (or 1FFF80h–1FFF87h in word mode).

Customers may opt to have their code programmed by Spansion through the Spansion ExpressFlash service. Spansion programs the customer’s code, with or without the random ESN. The devices are then shipped from the Spansion factory with the Secured Silicon Sector permanently locked. Contact a Spansion representative for details on using the Spansion ExpressFlash service.

Customer Lockable: Secured Silicon Sector NOT Programmed or Protected at the Factory

The customer lockable version allows the Secured Silicon Sector to be programmed once, and then permanently locked after it ships from Spansion. Note that the accelerated programming (ACC) and unlock bypass functions are not available when programming the Secured Silicon Sector.

The Secured Silicon Sector area can be protected using the following procedures:

- Write the three-cycle Enter Secured Silicon Region command sequence, and then follow the in-system sector protect algorithm as shown in [Figure 2 on page 25](#), except that *RESET#* may be at either V_{IH} or V_{ID} . This allows in-system protection of the Secured Silicon Sector without

raising any device pin to a high voltage. Note that this method is only applicable to the Secured Silicon Sector.

- To verify the protect/unprotect status of the Secured Silicon Sector, follow the algorithm shown in [Figure 3 on page 27](#).

Once the Secured Silicon Sector is locked and verified, the system must write the Exit Secured Silicon Sector Region command sequence to return to reading and writing the remainder of the array.

The Secured Silicon Sector protection must be used with caution since, once protected, there is no procedure available for unprotecting the Secured Silicon Sector area, and none of the bits in the Secured Silicon Sector memory space can be modified in any way.

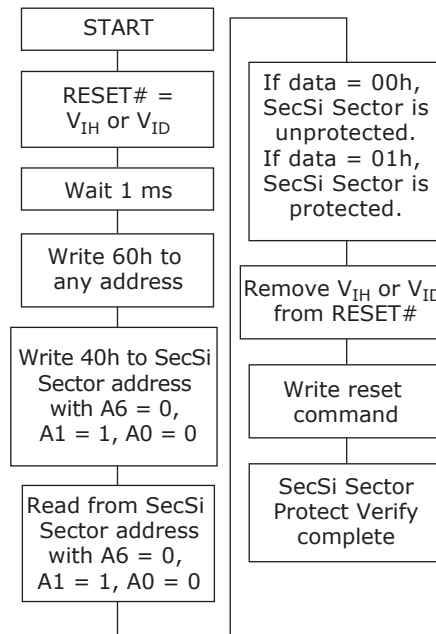

Figure 3. Secured Silicon Sector Protect Verify

Hardware Data Protection

The command sequence requirement of unlock cycles for programming or erasing provides data protection against inadvertent writes (refer to [Table 17 on page 37](#) for command definitions). In addition, the following hardware data protection measures prevent accidental erasure or programming, which might otherwise be caused by spurious system level signals during V_{CC} power-up and power-down transitions, or from system noise.

Low V_{CC} Write Inhibit

When V_{CC} is less than V_{LKO} , the device does not accept any write cycles. This protects data during V_{CC} power-up and power-down. The command register and all internal program/erase circuits are disabled, and the device resets. Subsequent writes are ignored until V_{CC} is greater than V_{LKO} . The system must provide the proper signals to the control pins to prevent unintentional writes when V_{CC} is greater than V_{LKO} .

Write Pulse “Glitch” Protection

Noise pulses of less than 5 ns (typical) on $OE\#$, $CE\#$ or $WE\#$ do not initiate a write cycle.

Logical Inhibit

Write cycles are inhibited by holding any one of $OE\# = V_{IL}$, $CE\# = V_{IH}$ or $WE\# = V_{IH}$. To initiate a write cycle, $CE\#$ and $WE\#$ must be a logical zero while $OE\#$ is a logical one.

Power-Up Write Inhibit

If $WE\# = CE\# = V_{IL}$ and $OE\# = V_{IH}$ during power up, the device does not accept commands on the rising edge of $WE\#$. The internal state machine is automatically reset to reading array data on power-up.

Common Flash Memory Interface (CFI)

The Common Flash Interface (CFI) specification outlines device and host system software interrogation handshake, which allows specific vendor-specified software algorithms to be used for entire families of devices. Software support can then be device-independent, JEDEC ID-independent, and forward- and backward-compatible for the specified flash device families. Flash vendors can standardize their existing interfaces for long-term compatibility.

This device enters the CFI Query mode when the system writes the CFI Query command, 98h, to address 55h in word mode (or address AAh in byte mode), any time the device is ready to read array data. The system can read CFI information at the addresses given in Tables 12–15. In word mode, the upper address bits (A7–MSB) must be all zeros. To terminate reading CFI data, the system must write the reset command.

The system can also write the CFI query command when the device is in the autoselect mode. The device enters the CFI query mode, and the system can read CFI data at the addresses given in Tables 12–15. The system must write the reset command to return the device to the autoselect mode.

For further information, please contact a Spansion representative for a copy of this document.

Table 12. CFI Query Identification String

Addresses	Addresses (Models 03, 04 Byte Mode Only)	Data	Description
10h 11h 12h	20h 22h 24h	0051h 0052h 0059h	Query Unique ASCII string <i>QRY</i>
13h 14h	26h 28h	0002h 0000h	Primary OEM Command Set
15h 16h	2Ah 2Ch	0040h 0000h	Address for Primary Extended Table
17h 18h	2Eh 30h	0000h 0000h	Alternate OEM Command Set (00h = none exists)
19h 1Ah	32h 34h	0000h 0000h	Address for Alternate OEM Extended Table (00h = none exists)

Table I3. System Interface String

Addresses	Addresses (Models 03, 04 Byte Mode Only)	Data	Description
1Bh	36h	0027h	V _{CC} Min. (write/erase) D7–D4: volt, D3–D0: 100 millivolt
1Ch	38h	0036h	V _{CC} Max. (write/erase) D7–D4: volt, D3–D0: 100 millivolt
1Dh	3Ah	0000h	V _{PP} Min. voltage (00h = no V _{PP} pin present)
1Eh	3Ch	0000h	V _{PP} Max. voltage (00h = no V _{PP} pin present)
1Fh	3Eh	0004h	Typical timeout per single byte/word write 2 ^N μs
20h	40h	0000h	Typical timeout for Min. size buffer write 2 ^N μs (00h = not supported)
21h	42h	000Ah	Typical timeout per individual block erase 2 ^N ms
22h	44h	0000h	Typical timeout for full chip erase 2 ^N ms (00h = not supported)
23h	46h	0005h	Max. timeout for byte/word write 2 ^N times typical
24h	48h	0000h	Max. timeout for buffer write 2 ^N times typical
25h	4Ah	0004h	Max. timeout per individual block erase 2 ^N times typical
26h	4Ch	0000h	Max. timeout for full chip erase 2 ^N times typical (00h = not supported)

Table I4. Device Geometry Definition (Sheet I of 2)

Addresses	Addresses (Models 03, 04 Byte Mode Only)	Data	Description
27h	4Eh	0016h	Device Size = 2 ^N byte
28h 29h	50h 52h	000xh 0000h	Flash Device Interface description (refer to CFI publication 100) (0 = Model 00, 2 = Models 03, 04)
2Ah 2Bh	54h 56h	0000h 0000h	Max. number of byte in multi-byte write = 2 ^N (00h = not supported)
2Ch	58h	000xh	Number of Erase Block Regions within device (1 = Model 00, 2 = Models 03, 04)
2Dh 2Eh 2Fh 30h	5Ah 5Ch 5Eh 60h	00xxh 0000h 00x0h 000xh	Erase Block Region 1 Information (refer to the CFI specification or CFI publication 100) (003F, 0000, 0000, 0001) = Model 00 (0007, 0000, 0020, 0000) = Models 03, 04
31h 32h 33h 34h	62h 64h 66h 68h	00xxh 0000h 0020h 000xh	Erase Block Region 2 Information (0000, 0000, 0000, 0000) = Model 00 (003E, 0000, 0000, 0001) = Models 03, 04
35h 36h 37h 38h	6Ah 6Ch 6Eh 70h	0000h 0000h 0000h 0000h	Erase Block Region 3 Information

Table I4. Device Geometry Definition (Sheet 2 of 2)

39h 3Ah 3Bh 3Ch	72h 74h 76h 78h	0000h 0000h 0000h 0000h	Erase Block Region 4 Information
--------------------------	--------------------------	----------------------------------	----------------------------------

Table I5. Primary Vendor-Specific Extended Query

Addresses	Addresses (Models 03, 04 Byte Mode Only)	Data	Description
40h 41h 42h	80h 82h 84h	0050h 0052h 0049h	Query-unique ASCII string "PRI"
43h	86h	0031h	Major version number, ASCII
44h	88h	0031h	Minor version number, ASCII
45h	8Ah	000xh	Address Sensitive Unlock 0 = Required (Models 03, 04), 1 = Not Required (Model 00)
46h	8Ch	0002h	Erase Suspend 0 = Not Supported, 1 = To Read Only, 2 = To Read & Write
47h	8Eh	0001h	Sector Protect 0 = Not Supported, X = Number of sectors in per group
48h	90h	0001h	Sector Temporary Unprotect 00 = Not Supported, 01 = Supported
49h	92h	0004h	Sector Protect/Unprotect scheme 01 = 29F040 mode, 02 = 29F016 mode, 03 = 29F400 mode, 04 = 29LV800A mode
4Ah	94h	0000h	Simultaneous Operation 00 = Not Supported, 01 = Supported
4Bh	96h	0000h	Burst Mode Type 00 = Not Supported, 01 = Supported
4Ch	98h	0000h	Page Mode Type 00 = Not Supported, 01 = 4 Word Page, 02 = 8 Word Page
4Dh	9Ah	00B5h	ACC (Acceleration) Supply Minimum 00h = Not Supported, D7-D4: Volt, D3-D0: 100 mV
4Eh	9Ch	00C5h	ACC (Acceleration) Supply Maximum 00h = Not Supported, D7-D4: Volt, D3-D0: 100 mV
4Fh	9Eh	000xh	Top/Bottom Boot Sector Flag (0 = Model 00, 3 = Model 03, 2 = Model 04)

Command Definitions

Writing specific address and data commands or sequences into the command register initiates device operations. [Table 17 on page 37](#) defines the valid register command sequences. Writing **incorrect address and data values** or writing them in the **improper sequence** resets the device to reading array data.

All addresses are latched on the falling edge of WE# or CE#, whichever happens later. All data is latched on the rising edge of WE# or CE#, whichever happens first. Refer to the appropriate timing diagrams under [AC Characteristics](#).

Reading Array Data

The device is automatically set to reading array data after device power-up. No commands are required to retrieve data. The device is also ready to read array data after completing an Embedded Program or Embedded Erase algorithm.

After the device accepts an Erase Suspend command, the device enters the Erase Suspend mode. The system can read array data using the standard read timings, except that if it reads at an address within erase-suspended sectors, the device outputs status data. After completing a programming operation in the Erase Suspend mode, the system may once again read array data with the same exception. See [Erase Suspend/Erase Resume Commands on page 34](#) for more information on this mode.

The system *must* issue the reset command in order to re-enable the device for reading array data if DQ5 goes high, or while in the autoselect mode. See [Reset Command on page 31](#).

See also [Requirements for Reading Array Data on page 11](#) for more information. The [Read Operations on page 49](#) provides the read parameters, and [Figure 14 on page 49](#) shows the timing diagram.

Reset Command

Writing the reset command to the device resets the device to reading array data. Address bits are don't care for this command.

The reset command may be written between the sequence cycles in an erase command sequence before erasing begins. This resets the device to reading array data. Once erasure begins, however, the device ignores reset commands until the operation is complete.

The reset command may be written between the sequence cycles in a program command sequence before programming begins. This resets the device to reading array data (also applies to programming in Erase Suspend mode). Once programming begins, however, the device ignores reset commands until the operation is complete.

The reset command may be written between the sequence cycles in an autoselect command sequence. Once in the autoselect mode, the reset command *must* be written to return to reading array data (also applies to autoselect during Erase Suspend).

If DQ5 goes high during a program or erase operation, writing the reset command returns the device to reading array data (also applies during Erase Suspend).

Autoselect Command Sequence

The autoselect command sequence allows the host system to access the manufacturer and device codes, and determine whether a sector is protected. [Table 17 on page 37](#) shows the address and data requirements. This method is an alternative to that shown in [Table on page 20](#), which is intended for PROM programmers and requires V_{ID} on address bit A9.

The autoselect command sequence is initiated by writing two unlock cycles, followed by the autoselect command. The device then enters the autoselect mode, and the system may read at any address any number of times, without initiating another command sequence.

A read cycle at address 0XXX00h retrieves the manufacturer code. A read cycle at address 0XXX01h returns the device code. A read cycle containing a sector address (SA) and the address 02h in word mode (or 04h in byte mode) returns 01h if that sector is protected, or 00h if it is unprotected. Refer to [Table 2 on page 14](#) and [Table 4 on page 16](#) for valid sector addresses.

The system must write the reset command to exit the autoselect mode and return to reading array data.

Enter Secured Silicon Sector/Exit Secured Silicon Sector Command Sequence

The Secured Silicon Sector region provides a secured data area containing a random, sixteen-byte electronic serial number (ESN). The system can access the Secured Silicon Sector region by issuing the three-cycle Enter Secured Silicon Sector command sequence. The device continues to access the Secured Silicon Sector region until the system issues the four-cycle Exit Secured Silicon Sector command sequence. The Exit Secured Silicon Sector command sequence returns the device to normal operation. [Table 16 on page 36](#) and [Table 17 on page 37](#) show the addresses and data requirements for both command sequences. Note that the ACC function and unlock bypass modes are not available when the device enters the Secured Silicon Sector. See also [Secured Silicon Sector Flash Memory Region on page 26](#) for further information.

Word/Byte Program Command Sequence

Models 03, 04 may program the device by word or byte, depending on the state of the BYTE# pin. Model 00 may program the device by byte only. Programming is a four-bus-cycle operation. The program command sequence is initiated by writing two unlock write cycles, followed by the program set-up command. The program address and data are written next, which in turn initiate the Embedded Program algorithm. The system is *not* required to provide further controls or timings. The device automatically generates the program pulses and verifies the programmed cell margin. [Table 17 on page 37](#) shows the address and data requirements for the byte program command sequence.

When the Embedded Program algorithm is complete, the device then returns to reading array data and addresses are no longer latched. The system can determine the status of the program operation by using DQ7, DQ6, or RY/BY#. See [Write Operation Status on page 38](#) for information on these status bits.

Any commands written to the device during the Embedded Program Algorithm are ignored. Note that a **hardware reset** immediately terminates the programming operation. The Byte Program command sequence should be reinitiated once the device has reset to reading array data, to ensure data integrity.

Programming is allowed in any sequence and across sector boundaries. **A bit cannot be programmed from a 0 back to a 1.** Attempting to do so may halt the operation and set DQ5 to 1, or cause the Data# Polling algorithm to indicate the operation was successful. However, a succeeding read will show that the data is still 0. Only erase operations can convert a 0 to a 1.

Unlock Bypass Command Sequence

The unlock bypass feature allows the system to program bytes or words to the device faster than using the standard program command sequence. The unlock bypass command sequence is initiated by first writing two unlock cycles. This is followed by a third write cycle containing the unlock bypass command, 20h. The device then enters the unlock bypass mode. A two-cycle unlock bypass program command sequence is all that is required to program in this mode. The first cycle in this sequence contains the unlock bypass program command, A0h; the second cycle contains the program address and data. Additional data is programmed in the same manner. This mode dispenses with the initial two unlock cycles required in the standard program command sequence, resulting in faster total programming time. [Table 17 on page 37](#) shows the requirements for the command sequence.

During the unlock bypass mode, only the Unlock Bypass Program and Unlock Bypass Reset commands are valid. To exit the unlock bypass mode, the system must issue the two-cycle unlock

bypass reset command sequence. The first cycle must contain the data 90h; the second cycle the data 00h. Addresses are don't care for both cycles. The device then returns to reading array data.

Figure 4 on page 33 illustrates the algorithm for the program operation. See the Erase/Program Operations on page 53 for parameters, and to Figure 18 on page 54 for timing diagrams.

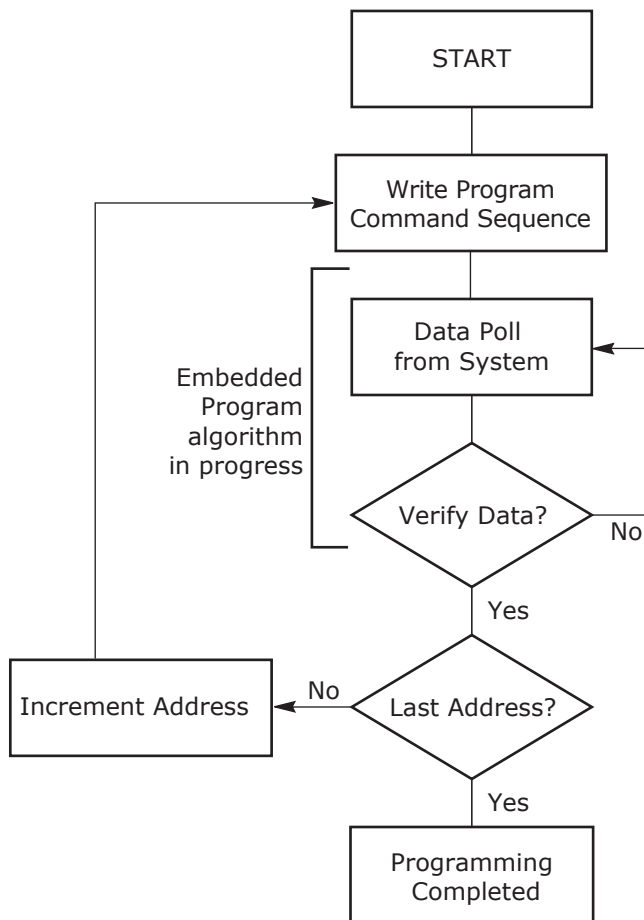

NOTE: See Table 17 for program command sequence.

Figure 4. Program Operation

Chip Erase Command Sequence

Chip erase is a six bus-cycle operation. The chip erase command sequence is initiated by writing two unlock cycles, followed by a set-up command. Two additional unlock write cycles are then followed by the chip erase command, which in turn invokes the Embedded Erase algorithm. The device does *not* require the system to preprogram prior to erase. The Embedded Erase algorithm automatically preprograms and verifies the entire memory for an all zero data pattern prior to electrical erase. The system is not required to provide any controls or timings during these operations. Table 17 on page 37 shows the address and data requirements for the chip erase command sequence.

Any commands written to the chip during the Embedded Erase algorithm are ignored. Note that a **hardware reset** during the chip erase operation immediately terminates the operation. The Chip Erase command sequence should be reinitiated once the device has returned to reading array data, to ensure data integrity.

The system can determine the status of the erase operation by using DQ7, DQ6, DQ2, or RY/BY#. See Write Operation Status on page 38 for information on these status bits. When the Embedded

Erase algorithm is complete, the device returns to reading array data and addresses are no longer latched.

Figure 5 on page 35 illustrates the algorithm for the erase operation. See [Erase/Program Operations on page 53](#) for parameters, and to [Figure 19 on page 55](#) for timing diagrams.

Sector Erase Command Sequence

Sector erase is a six bus cycle operation. The sector erase command sequence is initiated by writing two unlock cycles, followed by a set-up command. Two additional unlock write cycles are then followed by the address of the sector to be erased, and the sector erase command. [Table 17 on page 37](#) shows the address and data requirements for the sector erase command sequence.

The device does *not* require the system to preprogram the memory prior to erase. The Embedded Erase algorithm automatically programs and verifies the sector for an all zero data pattern prior to electrical erase. The system is not required to provide any controls or timings during these operations.

After the command sequence is written, a sector erase time-out of 50 μ s begins. During the time-out period, additional sector addresses and sector erase commands may be written. Loading the sector erase buffer may be done in any sequence, and the number of sectors may be from one sector to all sectors. The time between these additional cycles must be less than 50 μ s, otherwise the last address and command might not be accepted, and erasure may begin. It is recommended that processor interrupts be disabled during this time to ensure all commands are accepted. The interrupts can be re-enabled after the last Sector Erase command is written. If the time between additional sector erase commands can be assumed to be less than 50 μ s, the system need not monitor DQ3. **Any command other than Sector Erase or Erase Suspend during the time-out period resets the device to reading array data.** The system must rewrite the command sequence and any additional sector addresses and commands.

The system can monitor DQ3 to determine if the sector erase timer has timed out. (See the [DQ3: Sector Erase Timer](#) section.) The time-out begins from the rising edge of the final WE# pulse in the command sequence.

Once the sector erase operation has begun, only the Erase Suspend command is valid. All other commands are ignored. Note that a **hardware reset** during the sector erase operation immediately terminates the operation. The Sector Erase command sequence should be reinitiated once the device has returned to reading array data, to ensure data integrity.

When the Embedded Erase algorithm is complete, the device returns to reading array data and addresses are no longer latched. The system can determine the status of the erase operation by using DQ7, DQ6, DQ2, or RY/BY#. (Refer to [Write Operation Status](#) for information on these status bits.)

Figure 5 on page 35 illustrates the algorithm for the erase operation. Refer to [Erase/Program Operations on page 53](#) for parameters, and to [Figure 19 on page 55](#) for timing diagrams.

Erase Suspend/Erase Resume Commands

The Erase Suspend command allows the system to interrupt a sector erase operation and then read data from, or program data to, any sector not selected for erasure. This command is valid only during the sector erase operation, including the 50- μ s time-out period during the sector erase command sequence. The Erase Suspend command is ignored if it is written during the chip erase operation or Embedded Program algorithm. Writing the Erase Suspend command during the Sector Erase time-out immediately terminates the time-out period and suspends the erase operation. Addresses are don't cares when writing the Erase Suspend command.

When the Erase Suspend command is written during a sector erase operation, the device requires a maximum of 20 μ s to suspend the erase operation. However, when the Erase Suspend command

is written during the sector erase time-out, the device immediately terminates the time-out period and suspends the erase operation.

After the erase operation has been suspended, the system can read array data from or program data to any sector not selected for erasure. (The device *erase suspends* all sectors selected for erasure.) Normal read and write timings and command definitions apply. Reading at any address within erase-suspended sectors produces status data on DQ7–DQ0. The system can use DQ7, or DQ6 and DQ2 together, to determine if a sector is actively erasing or is erase-suspended. See [Write Operation Status on page 38](#) for information on these status bits.

After an erase-suspended program operation is complete, the system can once again read array data within non-suspended sectors. The system can determine the status of the program operation using the DQ7 or DQ6 status bits, just as in the standard program operation. See [Write Operation Status on page 38](#) for more information.

The system may also write the autoselect command sequence when the device is in the Erase Suspend mode. The device allows reading autoselect codes even at addresses within erasing sectors, since the codes are not stored in the memory array. When the device exits the autoselect mode, the device reverts to the Erase Suspend mode, and is ready for another valid operation. See [Autoselect Command Sequence on page 31](#) for more information.

The system must write the Erase Resume command (address bits are *don't care*) to exit the erase suspend mode and continue the sector erase operation. Further writes of the Resume command are ignored. Another Erase Suspend command can be written after the device has resumed erasing.

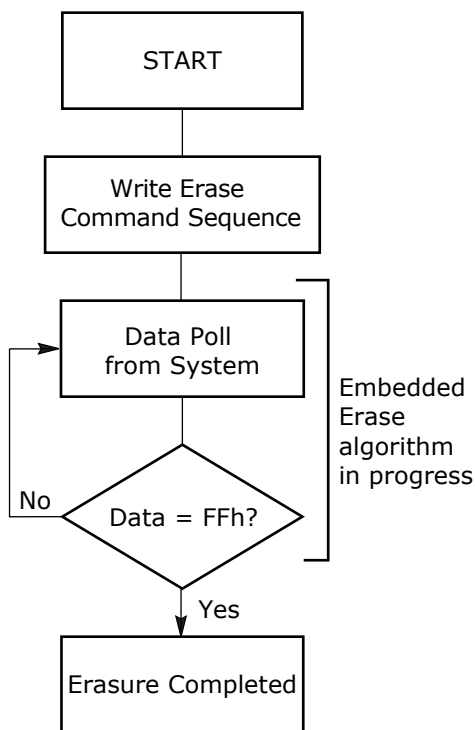

Notes:

See [Table 17](#) for erase command sequence.

See [DQ3: Sector Erase Timer on page 43](#) for more information.

Figure 5. Erase Operation

Command Definitions

Table 16. S29AL032D Command Definitions — Model 00

Command Sequence (Note 1)	Cycles	Bus Cycles (Notes 2–4)											
		First		Second		Third		Fourth		Fifth		Sixth	
		Addr	Data	Addr	Data	Addr	Data	Addr	Data	Addr	Data	Addr	Data
Read (Note 5)	1	RA	RD										
Reset (Note 7)	1	XXX	F0										
Autoselect (Note 7)	Manufacturer ID (Note 8)	4	XXX	AA	XXX	55	0XXXXX	90	0XXX00	01			
	Device ID (Note 8)	4	XXX	AA	XXX	55	0XXXXX	90	0XXX01	A3			
	Secured Silicon Sector Factory Protect (Note 15)	4	AAA	AA	555	55	AAA	90	X06	85/05			
	Sector Protect Verify (Note 9)	4	XXX	AA	XXX	55	0XXXXX or 2XXXXX	90	SA X02	00			
	XXX	XXX	01										
Enter Secured Silicon Sector Region	3	XXX	AA	XXX	55	XXX	88	XXX					
Exit Secured Silicon Sector Region	4	XXX	AA	XXX	55	XXX	90	XXX	00				
Byte Program	4	XXX	AA	XXX	55	XXX	A0	PA	PD				
Unlock Bypass	3	XXX	AA	XXX	55	XXX	20						
Unlock Bypass Program (Note 10)	2	XXX	A0	PA	PD								
Unlock Bypass Reset (Note 11)	2	XXX	90	XXX	00								
Chip Erase	6	XXX	AA	XXX	55	XXX	80	XXX	AA	XXX	55	XXX	10
Sector Erase	6	XXX	AA	XXX	55	XXX	80	XXX	AA	XXX	55	SA	30
Erase Suspend (Note 12)	1	XXX	B0										
Erase Resume (Note 13)	1	XXX	30										
CFI Query (Note 14)	1	XXX	98										

Legend:

X = Don't care, RA = Address of the memory location to be read, RD = Data read from location RA during read operation, PA = Address of the memory location to be programmed. Addresses are latched on the falling edge of the WE# or CE# pulse. PD = Data to be programmed at location PA. Data is latched on the rising edge of WE# or CE# pulse. SA = Address of the sector to be erased or verified. Address bits A21–A16 uniquely select any sector.

Notes:

- See Table 1 on page 11 for descriptions of bus operations.
- All values are in hexadecimal.
- Except when reading array or autoselect data, all bus cycles are write operations.
- Address bits are don't care for unlock and command cycles, except when PA or SA is required.
- No unlock or command cycles required when device is in read mode.
- The Reset command is required to return to the read mode when the device is in the autoselect mode or if DQ5 goes high.
- The fourth cycle of the autoselect command sequence is a read cycle.
- In the third and fourth cycles of the command sequence, set A21 to 0.
- In the third cycle of the command sequence, address bit A21 must be set to 0 if verifying sectors 0–31, or to 1 if verifying sectors 32–64. The data in the fourth cycle is 00h for an unprotected sector/sector block and 01h for a protected sector/sector block.
- The Unlock Bypass command is required prior to the Unlock Bypass Program command.
- The Unlock Bypass Reset command is required to return to reading array data when the device is in the Unlock Bypass mode.
- The system may read and program functions in non-erasing sectors, or enter the autoselect mode, when in the Erase Suspend mode. The Erase Suspend command is valid only during a sector erase operation.
- The Erase Resume command is valid only during the Erase Suspend mode.
- Command is valid when device is ready to read array data or when device is in autoselect mode.
- The data is 85h for factory locked and 05h for not factory locked.

Table 17. S29AL032D Command Definitions — Models 03, 04

Command Sequence (Note 1)		Cycles	Bus Cycles (Notes 2–5)													
			First		Second		Third		Fourth		Fifth		Sixth			
			Addr	Data	Addr	Data	Addr	Data	Addr	Data	Addr	Data	Addr	Data		
Read (Note 6)		1	RA	RD												
Reset (Note 7)		1	XXX	F0												
Autoselect (Note 8)	Manufacturer ID	Word	4	555	AA	2AA	55	555	90	X00	01					
		Byte	4	AAA	AA	555	55	AAA	90	X01	22F6					
	Device ID, Model 03	Word	4	555	AA	2AA	55	555	90	X01	22F6					
		Byte	4	AAA	AA	555	55	AAA	90	X02	F6					
	Device ID, Model 04	Word	4	555	AA	2AA	55	555	90	X01	22F9					
		Byte	4	AAA	AA	555	55	AAA	90	X02	F9					
	Secured Silicon Sector Factory Protect Model 03, (Note 9)	Word	4	555	AA	2AA	55	555	90	X03	8D/0D					
		Byte	4	AAA	AA	555	55	AAA	90	X06	8D/0D					
	Secured Silicon Sector Factory Protect Model 04, (Note 9)	Word	4	555	AA	2AA	55	555	90	X03	9D/1D					
		Byte	4	AAA	AA	555	55	AAA	90	X06	9D/1D					
Sector Protect Verify (Note 10)	Word	4	555	AA	2AA	55	555	90	(SA) X02	XX00 XX01						
	Byte	4	AAA	AA	555	55	AAA	90	(SA) X04	00 01						
Enter Secured Silicon Sector Region	Word	3	555	AA	2AA	55	555	88								
	Byte	3	AAA	AA	555	55	AAA	88								
Exit Secured Silicon Sector Region	Word	4	555	AA	2AA	55	555	90	XXX	00						
	Byte	4	AAA	AA	555	55	AAA	90	XXX	00						
CFI Query (Note 11)	Word	1	55	98												
	Byte	1	AA	98												
Program	Word	4	555	AA	2AA	55	555	A0	PA	PD						
	Byte	4	AAA	AA	555	55	AAA	A0	PA	PD						
Unlock Bypass	Word	3	555	AA	2AA	55	555	20								
	Byte	3	AAA	AA	555	55	AAA	20								
Unlock Bypass Program (Note 12)		2	XXX	A0	PA	PD										
Unlock Bypass Reset (Note 13)		2	XXX	90	XXX	00										
Chip Erase	Word	6	555	AA	2AA	55	555	80	555	AA	2AA	55	555	10		
	Byte	6	AAA	AA	555	55	AAA	80	AAA	AA	555	55	AAA	10		
Sector Erase	Word	6	555	AA	2AA	55	555	80	555	AA	2AA	55	SA	30		
	Byte	6	AAA	AA	555	55	AAA	80	AAA	AA	555	55	SA	30		
Erase Suspend (Note 14)		1	XXX	B0												
Erase Resume (Note 15)		1	XXX	30												

Legend:

X = Don't care

RA = Address of the memory location to be read.

RD = Data read from location RA during read operation.

PA = Address of the memory location to be programmed. Addresses latch on the falling edge of the WE# or CE# pulse, whichever happens later.

PD = Data to be programmed at location PA. Data latches on the rising edge of WE# or CE# pulse, whichever happens first.

SA = Address of the sector to be verified (in autoselect mode) or erased. Address bits A19–A12 uniquely select any sector.

Notes:

1. See [Table 1 on page 11](#) for description of bus operations.
2. All values are in hexadecimal.
3. Except for the read cycle and the fourth cycle of the autoselect command sequence, all bus cycles are write cycles.
4. Data bits DQ15–DQ8 are don't cares for unlock and command cycles.
5. Address bits A19–A11 are don't cares for unlock and command cycles, unless SA or PA required.
6. No unlock or command cycles required when reading array data.
7. The Reset command is required to return to reading array data when device is in the autoselect mode, or if DQ5 goes high (while the device is providing status data).
8. The fourth cycle of the autoselect command sequence is a read cycle.
9. For Model 03, the data is 8Dh for factory locked and 0Dh for not factory locked. For Model 04, the data is 9Dh for factory locked and 1Dh for not factory locked.
10. The data is 00h for an unprotected sector and 01h for a protected sector. See "Autoselect Command Sequence" for more information.
11. Command is valid when device is ready to read array data or when device is in autoselect mode.
12. The Unlock Bypass command is required prior to the Unlock Bypass Program command.
13. The Unlock Bypass Reset command is required to return to reading array data when the device is in the unlock bypass mode. F0 is also acceptable.
14. The system may read and program in non-erasing sectors, or enter the autoselect mode, when in the Erase Suspend mode. The Erase Suspend command is valid only during a sector erase operation.
15. The Erase Resume command is valid only during the Erase Suspend mode.

Write Operation Status

The device provides several bits to determine the status of a write operation: DQ2, DQ3, DQ5, DQ6, DQ7, and RY/BY#. [Table 18 on page 43](#) and the following subsections describe the functions of these bits. DQ7, RY/BY#, and DQ6 each offer a method for determining whether a program or erase operation is complete or in progress. These three bits are discussed first.

DQ7: Data# Polling

The Data# Polling bit, DQ7, indicates to the host system whether an Embedded Algorithm is in progress or completed, or whether the device is in Erase Suspend. Data# Polling is valid after the rising edge of the final WE# pulse in the program or erase command sequence.

During the Embedded Program algorithm, the device outputs on DQ7 the complement of the datum programmed to DQ7. This DQ7 status also applies to programming during Erase Suspend. When the Embedded Program algorithm is complete, the device outputs the datum programmed to DQ7. The system must provide the program address to read valid status information on DQ7. If a program address falls within a protected sector, Data# Polling on DQ7 is active for approximately 1 μ s, then the device returns to reading array data.

During the Embedded Erase algorithm, Data# Polling produces a 0 on DQ7. When the Embedded Erase algorithm is complete, or if the device enters the Erase Suspend mode, Data# Polling produces a 1 on DQ7. This is analogous to the complement/true datum output described for the Embedded Program algorithm: the erase function changes all the bits in a sector to 1; prior to this, the device outputs the *complement*, or 0. The system must provide an address within any of the sectors selected for erasure to read valid status information on DQ7.

After an erase command sequence is written, if all sectors selected for erasing are protected, Data# Polling on DQ7 is active for approximately 100 μ s, then the device returns to reading array data. If not all selected sectors are protected, the Embedded Erase algorithm erases the unprotected sectors, and ignores the selected sectors that are protected.

When the system detects DQ7 has changed from the complement to true data, it can read valid data at DQ7–DQ0 on the *following* read cycles. This is because DQ7 may change asynchronously with DQ0–DQ6 while Output Enable (OE#) is asserted low. [Figure 21 on page 56](#), Data# Polling Timings (During Embedded Algorithms), under [AC Characteristics on page 49](#) illustrates this.

[Figure 18 on page 43](#) shows the outputs for Data# Polling on DQ7. [Figure 7 on page 42](#) shows the Data# Polling algorithm.

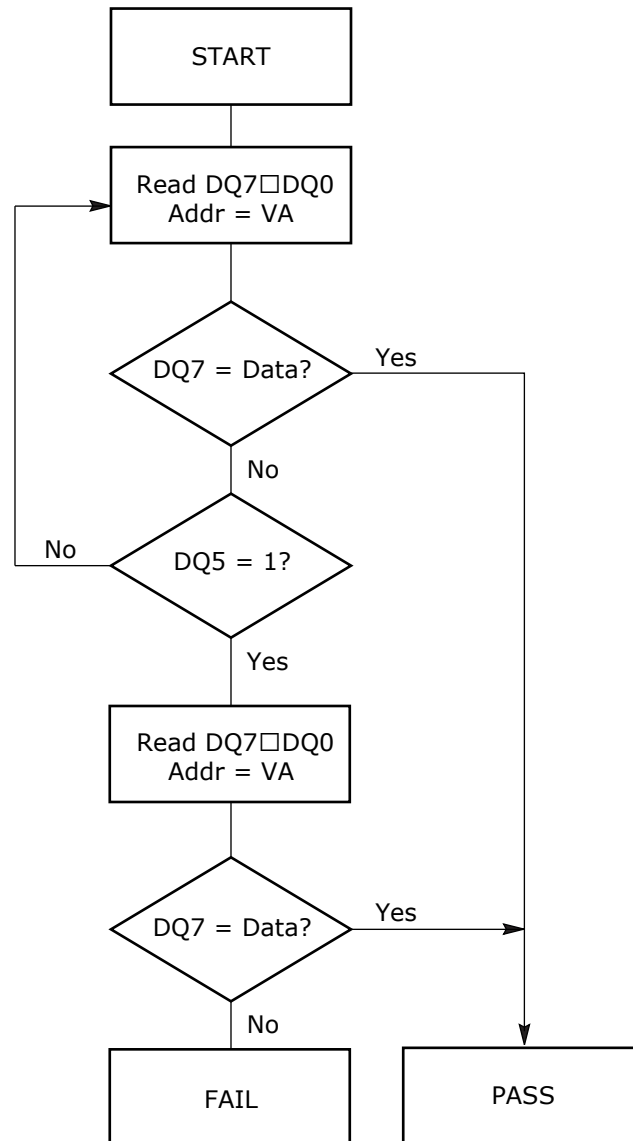
**Notes:**

1. VA = Valid address for programming. During a sector erase operation, a valid address is an address within any sector selected for erasure. During chip erase, a valid address is any non-protected sector address.
2. DQ7 should be rechecked even if DQ5 = 1 because DQ7 may change simultaneously with DQ5.

Figure 6. Data# Polling Algorithm**RY/BY#: Ready/Busy#**

The RY/BY# is a dedicated, open-drain output pin that indicates whether an Embedded Algorithm is in progress or complete. The RY/BY# status is valid after the rising edge of the final WE# pulse in the command sequence. Since RY/BY# is an open-drain output, several RY/BY# pins can be tied together in parallel with a pull-up resistor to V_{CC} .

If the output is low (Busy), the device is actively erasing or programming. (This includes programming in the Erase Suspend mode.) If the output is high (Ready), the device is ready to read array data (including during the Erase Suspend mode), or is in the standby mode.

[Table 18 on page 43](#) shows the outputs for RY/BY#. [Figure 14 on page 49](#), [Figure 15 on page 50](#), [Figure 18 on page 54](#) and [Figure 19 on page 55](#) shows RY/BY# for read, reset, program, and erase operations, respectively.

DQ6: Toggle Bit I

Toggle Bit I on DQ6 indicates whether an Embedded Program or Erase algorithm is in progress or complete, or whether the device has entered the Erase Suspend mode. Toggle Bit I may be read at any address, and is valid after the rising edge of the final WE# pulse in the command sequence (prior to the program or erase operation), and during the sector erase time-out.

During an Embedded Program or Erase algorithm operation, successive read cycles to any address cause DQ6 to toggle. (The system may use either OE# or CE# to control the read cycles.) When the operation is complete, DQ6 stops toggling.

After an erase command sequence is written, if all sectors selected for erasing are protected, DQ6 toggles for approximately 100 μ s, then returns to reading array data. If not all selected sectors are protected, the Embedded Erase algorithm erases the unprotected sectors, and ignores the selected sectors that are protected.

The system can use DQ6 and DQ2 together to determine whether a sector is actively erasing or is erase-suspended. When the device is actively erasing (that is, the Embedded Erase algorithm is in progress), DQ6 toggles. When the device enters the Erase Suspend mode, DQ6 stops toggling. However, the system must also use DQ2 to determine which sectors are erasing or erase-suspended. Alternatively, the system can use DQ7 (see the subsection on [DQ7: Data# Polling on page 38](#)).

If a program address falls within a protected sector, DQ6 toggles for approximately 1 μ s after the program command sequence is written, then returns to reading array data.

DQ6 also toggles during the erase-suspend-program mode, and stops toggling once the Embedded Program algorithm is complete.

[Table 18 on page 43](#) shows the outputs for Toggle Bit I on DQ6. [Figure 7 on page 42](#) shows the toggle bit algorithm in flowchart form, and the section [Reading Toggle Bits DQ6/DQ2 on page 41](#) explains the algorithm. [Figure 22 on page 56](#) shows the toggle bit timing diagrams. [Figure 23 on page 57](#) shows the differences between DQ2 and DQ6 in graphical form. See also the subsection on [DQ2: Toggle Bit II](#).

DQ2: Toggle Bit II

The *Toggle Bit II* on DQ2, when used with DQ6, indicates whether a particular sector is actively erasing (that is, the Embedded Erase algorithm is in progress), or whether that sector is erase-suspended. Toggle Bit II is valid after the rising edge of the final WE# pulse in the command sequence.

DQ2 toggles when the system reads at addresses within those sectors that have been selected for erasure. (The system may use either OE# or CE# to control the read cycles.) But DQ2 cannot distinguish whether the sector is actively erasing or is erase-suspended. DQ6, by comparison, indicates whether the device is actively erasing, or is in Erase Suspend, but cannot distinguish which sectors are selected for erasure. Thus, both status bits are required for sector and mode information. Refer to [Table 18 on page 43](#) to compare outputs for DQ2 and DQ6.

[Figure 7 on page 42](#) shows the toggle bit algorithm in flowchart form, and the section [Reading Toggle Bits DQ6/DQ2 on page 41](#) explains the algorithm. See also the [DQ6: Toggle Bit I](#) subsec-

tion. [Figure 22 on page 56](#) shows the toggle bit timing diagram. [Figure 23 on page 57](#) shows the differences between DQ2 and DQ6 in graphical form.

Reading Toggle Bits DQ6/DQ2

Refer to [Figure 7 on page 42](#) for the following discussion. Whenever the system initially begins reading toggle bit status, it must read DQ7–DQ0 at least twice in a row to determine whether a toggle bit is toggling. Typically, the system would note and store the value of the toggle bit after the first read. After the second read, the system would compare the new value of the toggle bit with the first. If the toggle bit is not toggling, the device has completed the program or erase operation. The system can read array data on DQ7–DQ0 on the following read cycle.

However, if after the initial two read cycles, the system determines that the toggle bit is still toggling, the system also should note whether the value of DQ5 is high (see the section on DQ5). If it is, the system should then determine again whether the toggle bit is toggling, since the toggle bit may have stopped toggling just as DQ5 went high. If the toggle bit is no longer toggling, then the device has successfully completed the program or erase operation. If it is still toggling, then the device had not complete the operation successfully, and the system must write the reset command in order to return to reading array data.

The remaining scenario is that the system initially determines that the toggle bit is toggling and DQ5 has not gone high. The system may continue to monitor the toggle bit and DQ5 through successive read cycles, determining the status as described in the previous paragraph. Alternatively, it may choose to perform other system tasks. In this case, the system must start at the beginning of the algorithm when it returns to determine the status of the operation (top of [Figure 7 on page 42](#)).

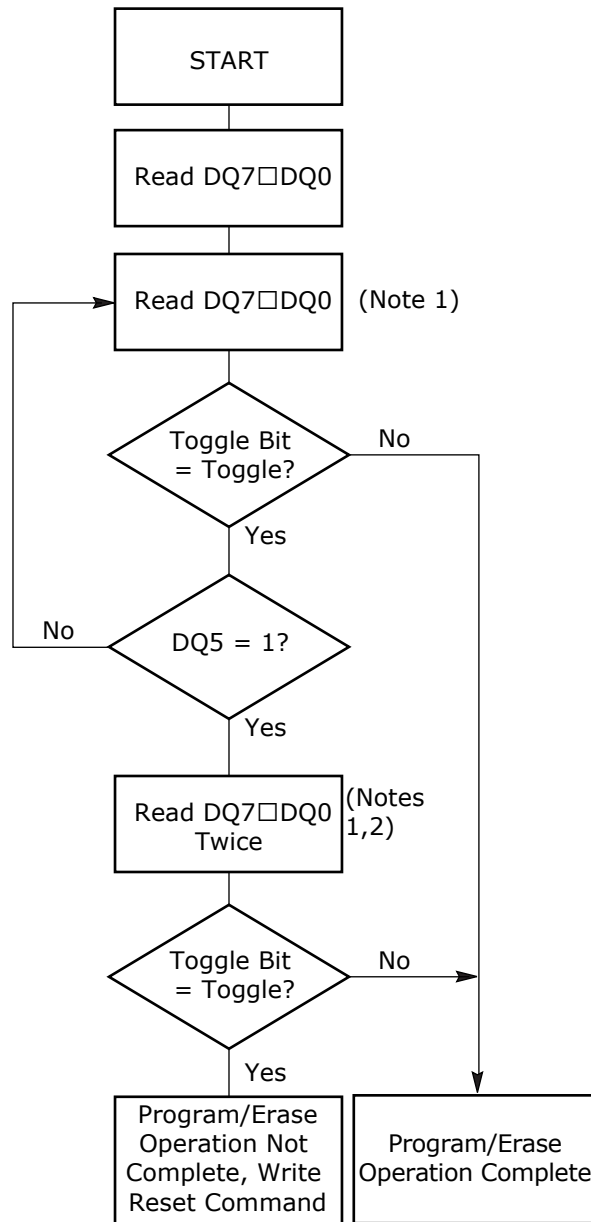

Notes:

1. Read toggle bit twice to determine whether or not it is toggling. See text.
2. Recheck toggle bit because it may stop toggling as DQ5 changes to 1. See text.

Figure 7. Toggle Bit Algorithm

DQ5: Exceeded Timing Limits

DQ5 indicates whether the program or erase time has exceeded a specified internal pulse count limit. Under these conditions DQ5 produces a 1. This is a failure condition that indicates the program or erase cycle was not successfully completed.

The DQ5 failure condition may appear if the system tries to program a 1 to a location that is previously programmed to 0. **Only an erase operation can change a 0 back to a 1.** Under this

condition, the device halts the operation, and when the operation has exceeded the timing limits, DQ5 produces a 1.

Under both these conditions, the system must issue the reset command to return the device to reading array data.

DQ3: Sector Erase Timer

After writing a sector erase command sequence, the system may read DQ3 to determine whether or not an erase operation has begun. (The sector erase timer does not apply to the chip erase command.) If additional sectors are selected for erasure, the entire time-out also applies after each additional sector erase command. When the time-out is complete, DQ3 switches from 0 to 1. The system may ignore DQ3 if the system can guarantee that the time between additional sector erase commands will always be less than 50 μ s. See also [Sector Erase Command Sequence on page 34](#).

After the sector erase command sequence is written, the system should read the status on DQ7 (Data# Polling) or DQ6 (Toggle Bit I) to ensure that the device accepts the command sequence, and then read DQ3. If DQ3 is 1, the internally controlled erase cycle has begun; all further commands (other than Erase Suspend) are ignored until the erase operation is complete. If DQ3 is 0, the device accepts additional sector erase commands. To ensure that the command has been accepted, the system software should check the status of DQ3 prior to and following each subsequent sector erase command. If DQ3 is high on the second status check, the last command might not have been accepted. [Table 18](#) shows the outputs for DQ3.

Table 18. Write Operation Status

Operation		DQ7 (Note 2)	DQ6	DQ5 (Note 1)	DQ3	DQ2 (Note 2)	RY/BY#
Standard Mode	Embedded Program Algorithm	DQ7#	Toggle	0	N/A	No toggle	0
	Embedded Erase Algorithm	0	Toggle	0	1	Toggle	0
Erase Suspend Mode	Reading within Erase Suspended Sector	1	No toggle	0	N/A	Toggle	1
	Reading within Non-Erase Suspended Sector	Data	Data	Data	Data	Data	1
	Erase-Suspend-Program	DQ7#	Toggle	0	N/A	N/A	0

Notes:

1. DQ5 switches to '1' when an Embedded Program or Embedded Erase operation exceeds the maximum timing limits. See [DQ5: Exceeded Timing Limits on page 42](#) for more information.
2. DQ7 and DQ2 require a valid address when reading status information. Refer to the appropriate subsection for further details.

Absolute Maximum Ratings

Storage Temperature	
Plastic Packages.	-65°C to +150°C
Ambient Temperature	
with Power Applied.	-65°C to +125°C
Voltage with Respect to Ground	
V_{CC} (Note 1).	-0.5 V to +4.0 V
A9, OE#, and RESET# (Note 2)	-0.5 V to +12.5 V
All other pins (Note 1)	-0.5 V to $V_{CC}+0.5$ V
Output Short Circuit Current (Note 3).	200 mA

Notes:

1. Minimum DC voltage on input or I/O pins is -0.5 V. During voltage transitions, input or I/O pins may overshoot V_{SS} to -2.0 V for periods of up to 20 ns. See Figure 8 on page 44. Maximum DC voltage on input or I/O pins is $V_{CC} + 0.5$ V. During voltage transitions, input or I/O pins may overshoot to $V_{CC} + 2.0$ V for periods up to 20 ns. See Figure 9 on page 44.
2. Minimum DC input voltage on pins A9, OE#, and RESET# is -0.5 V. During voltage transitions, A9, OE#, and RESET# may overshoot V_{SS} to -2.0 V for periods of up to 20 ns. See Figure 8 on page 44. Maximum DC input voltage on pin A9 is +12.5 V which may overshoot to 14.0 V for periods up to 20 ns.
3. No more than one output may be shorted to ground at a time. Duration of the short circuit should not be greater than one second.

Stresses above those listed under "Absolute Maximum Ratings" may cause permanent damage to the device. This is a stress rating only; functional operation of the device at these or any other conditions above those indicated in the operational sections of this data sheet is not implied. Exposure of the device to absolute maximum rating conditions for extended periods may affect device reliability.

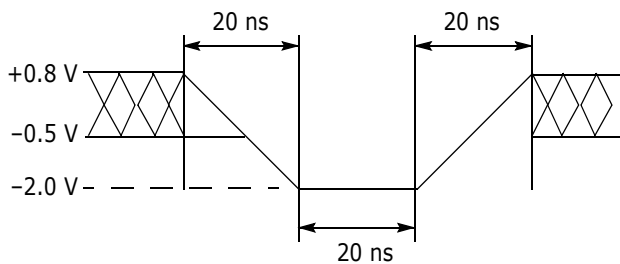

Figure 8. Maximum Negative Overshoot Waveform

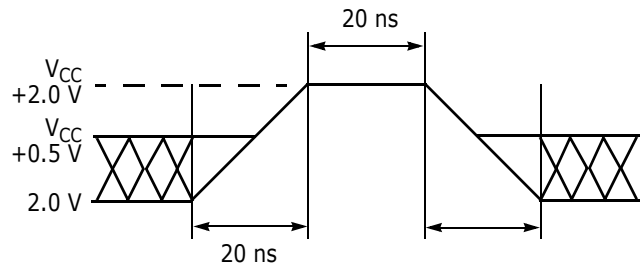

Figure 9. Maximum Positive Overshoot Waveform

Operating Ranges

Industrial (I) Devices

Ambient Temperature (T_A) -40°C to +85°C

Extended (N) Devices

Ambient Temperature (T_A) -40°C to +125°C

V_{CC} Supply Voltages

V_{CC} for standard voltage range 2.7 V to 3.6 V

Operating ranges define those limits between which the functionality of the device is guaranteed.

DC Characteristics

CMOS Compatible

Parameter	Description	Test Conditions	Min	Typ	Max	Unit	
I_{LI}	Input Load Current (Note 7)	$V_{IN} = V_{SS}$ to V_{CC} , $V_{CC} = V_{CC\ max}$			± 1.0	μA	
I_{LIT}	A9 Input Load Current	$V_{CC} = V_{CC\ max}$; A9 = 12.5 V			35	μA	
I_{LO}	Output Leakage Current	$V_{OUT} = V_{SS}$ to V_{CC} , $V_{CC} = V_{CC\ max}$			± 1.0	μA	
I_{CC1}	V_{CC} Active Read Current (Notes 1, 2)	CE# = V_{IL} , OE# = V_{IH} , Byte Mode	10 MHz		15	30	mA
			5 MHz		9	16	
			1 MHz		2	4	
		CE# = V_{IL} , OE# = V_{IH} , Word Mode	10 MHz		18	35	
			5 MHz		9	16	
			1 MHz		2	4	
I_{CC2}	V_{CC} Active Write Current (Notes 2, 3, 5)	CE# = V_{IL} , OE# = V_{IH}		15	35	mA	
I_{CC3}	V_{CC} Standby Current (Notes 2, 4)	CE#, RESET# = $V_{CC} \pm 0.3$ V		0.2	5	μA	
I_{CC4}	V_{CC} Standby Current During Reset (Notes 2, 4)	RESET# = $V_{SS} \pm 0.3$ V		0.2	5	μA	
I_{CC5}	Automatic Sleep Mode (Notes 2, 4, 6)	$V_{IH} = V_{CC} \pm 0.3$ V; $V_{IL} = V_{SS} \pm 0.3$ V		0.2	5	μA	
I_{ACC}	ACC Accelerated Program Current, Word or Byte	CE# = V_{IL} , OE# = V_{IH}	ACC pin		5	10	mA
			V_{CC} pin		15	30	mA
V_{IL}	Input Low Voltage		-0.5		0.8	V	
V_{IH}	Input High Voltage		$0.7 \times V_{CC}$		$V_{CC} + 0.3$	V	
V_{HH}	Voltage for WP#/ACC Sector Protect/ Unprotect and Program Acceleration	$V_{CC} = 3.0$ V $\pm 10\%$	11.5		12.5	V	
V_{ID}	Voltage for Autoselect and Temporary Sector Unprotect	$V_{CC} = 3.3$ V	11.5		12.5	V	
V_{OL}	Output Low Voltage	$I_{OL} = 4.0$ mA, $V_{CC} = V_{CC\ min}$			0.45	V	
V_{OH1}	Output High Voltage	$I_{OH} = -2.0$ mA, $V_{CC} = V_{CC\ min}$	2.4			V	
V_{OH2}		$I_{OH} = -100$ μA , $V_{CC} = V_{CC\ min}$	$V_{CC} - 0.4$			V	
V_{LKO}	Low V_{CC} Lock-Out Voltage (Note 4)		2.3		2.5	V	

Notes:

1. The I_{CC} current listed is typically less than 2 mA/MHz, with OE# at V_{IH} . Typical V_{CC} is 3.0 V.
2. Maximum I_{CC} specifications are tested with $V_{CC} = V_{CC\ max}$.
3. I_{CC} active while Embedded Erase or Embedded Program is in progress.
4. At extended temperature range ($> +85^{\circ}C$), maximum current is 15 μA .
5. Automatic sleep mode enables the low power mode when addresses remain stable for $t_{ACC} + 30$ ns. Typical sleep mode current is 200 nA.
6. Not 100% tested.
7. On the ACC pin only, the maximum input load current when ACC = V_{IL} is ± 5.0 μA .

DC Characteristics

Zero Power Flash

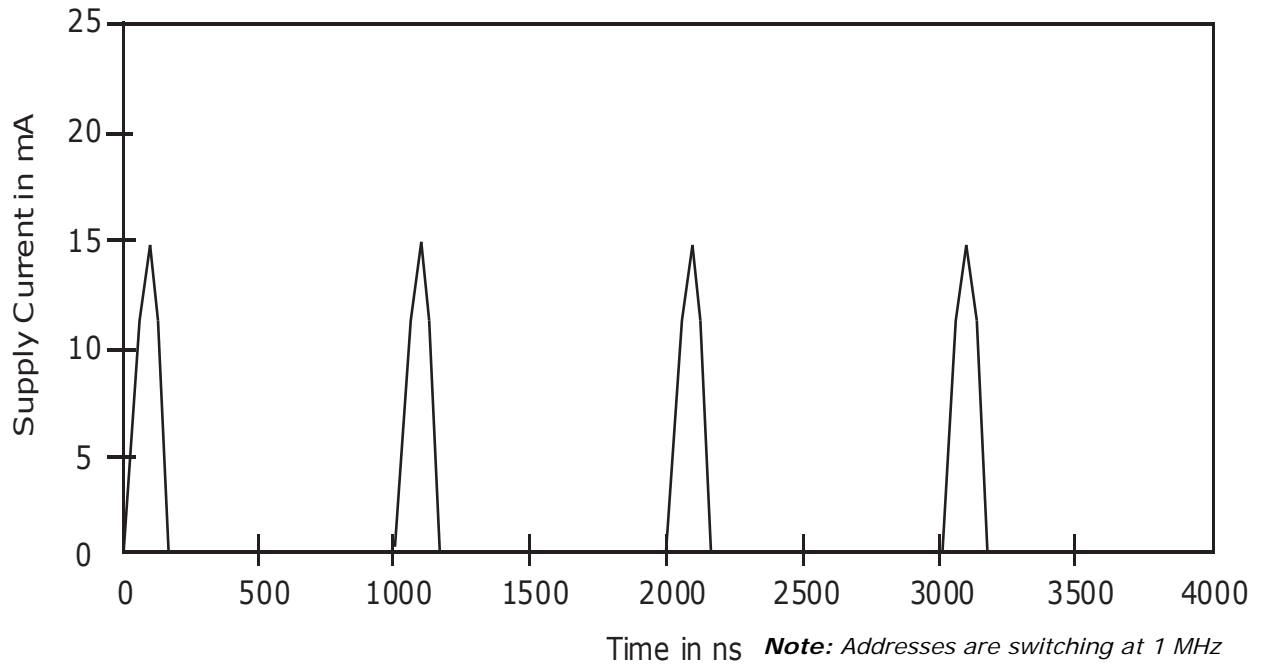
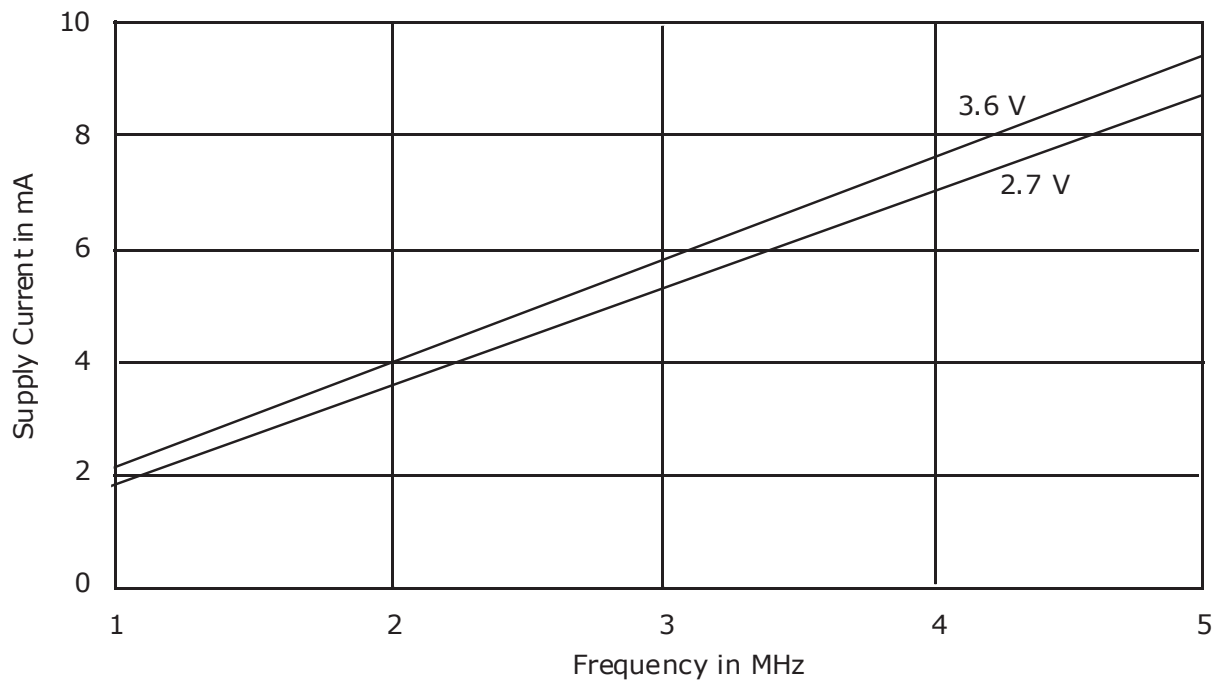

Figure 10. I_{CC1} Current vs. Time (Showing Active and Automate)



Note: $T = 25^{\circ}\text{C}$

Figure 11. Typical I_{CC1} vs. Frequency

Test Conditions

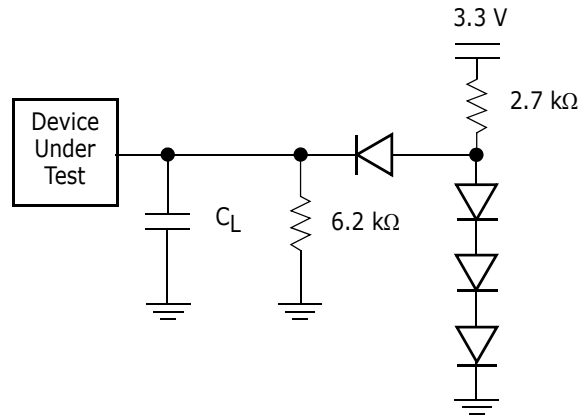





Note: Diodes are IN3064 or equivalent

Figure I2. Test Setup

Table I9. Test Specifications

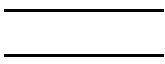
Speed Option	70	90	Unit
Output Load	1 TTL gate		
Output Load Capacitance, C_L (including jig capacitance)	30	100	pF
Input Rise and Fall Times	5		ns
Input Pulse Levels	0.0 or V_{CC}		V
Input timing measurement reference levels	0.5 V_{CC}		V
Output timing measurement reference levels	0.5 V_{CC}		V

Key to Switching Waveforms

Waveform	Inputs	Outputs
	Steady	
	Changing from H to L	
	Changing from L to H	
	Don't Care, Any Change Permitted	Changing, State Unknown
	Does Not Apply	Center Line is High Impedance State (High Z)

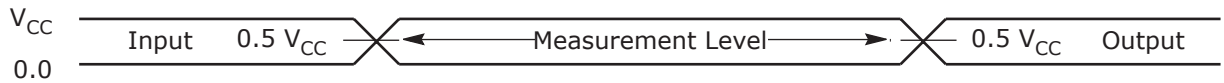

Figure I3. Input Waveforms and Measurement Levels

AC Characteristics

Read Operations

Parameter		Description	Test Setup	Speed Options		Unit	
JEDEC	Std			70	90		
t_{AVAV}	t_{RC}	Read Cycle Time (Note 1)		Min	70	90	ns
t_{AVQV}	t_{ACC}	Address to Output Delay	CE# = V_{IL} OE# = V_{IL}	Max	70	90	ns
t_{ELQV}	t_{CE}	Chip Enable to Output Delay	OE# = V_{IL}	Max	70	90	ns
t_{GLQV}	t_{OE}	Output Enable to Output Delay		Max	30	35	ns
t_{EHQZ}	t_{DF}	Chip Enable to Output High Z (Note 1)		Max	16		ns
t_{GHQZ}	t_{DF}	Output Enable to Output High Z (Note 1)		Max	16		ns
	$t_{SR/W}$	Latency Between Read and Write Operations		Min	20		ns
	t_{OEh}	Output Enable Hold Time (Note 1)	Read	Min	0		ns
			Toggle and Data# Polling	Min	10		ns
t_{AXQX}	t_{OH}	Output Hold Time From Addresses, CE# or OE#, Whichever Occurs First (Note 1)		Min	0		ns

Notes:

1. Not 100% tested.
2. See Figure 12 on page 47 and Table 19 on page 47 for test specifications.

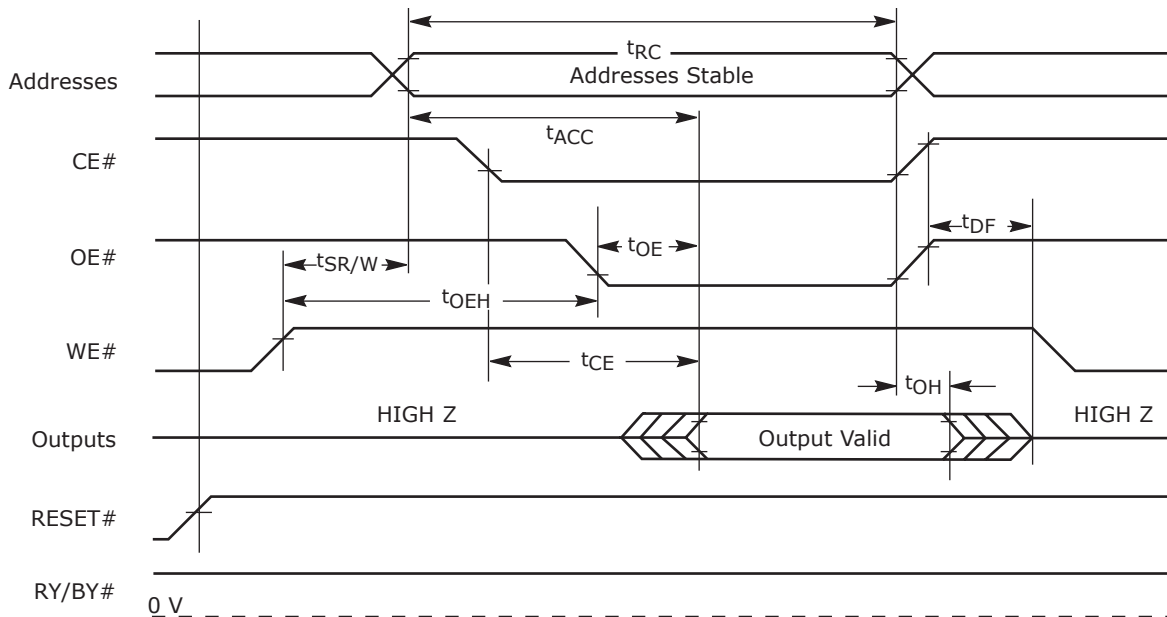

Figure 14. Read Operations Timings

AC Characteristics

Hardware Reset (RESET#)

Parameter		Description	Test Setup		All Speed Options	Unit
JEDEC	Std					
	t_{READY}	RESET# Pin Low (During Embedded Algorithms) to Read or Write (See Note)		Max	20	μs
	t_{READY}	RESET# Pin Low (NOT During Embedded Algorithms) to Read or Write (See Note)		Max	500	ns
	t_{RP}	RESET# Pulse Width		Min	500	ns
	t_{RH}	RESET# High Time Before Read (See Note)		Min	50	ns
	t_{RPD}	RESET# Low to Standby Mode		Min	20	μs
	t_{RB}	RY/BY# Recovery Time		Min	0	ns

Note: Not 100% tested.

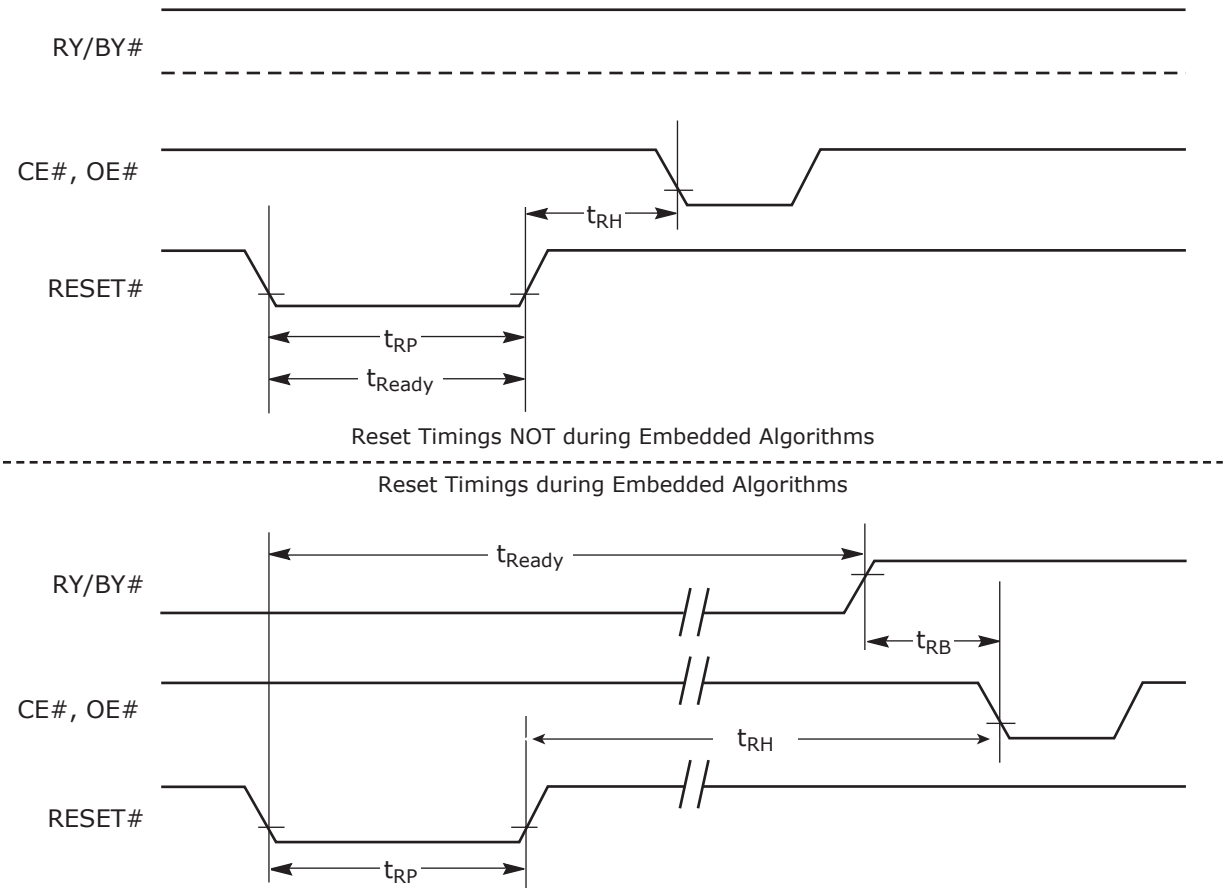

Figure 15. RESET# Timings

AC Characteristics

Word/Byte Configuration (BYTE#) (Models 03, 04 Only)

Parameter		Description		Speed Options		Unit
JEDEC	Std			70	90	
	t_{ELFL}/t_{ELFH}	CE# to BYTE# Switching Low or High	Max	5	ns	
	t_{FLQZ}	BYTE# Switching Low to Output HIGH Z	Max	16	ns	
	t_{FHQV}	BYTE# Switching High to Output Active	Min	70	90	ns

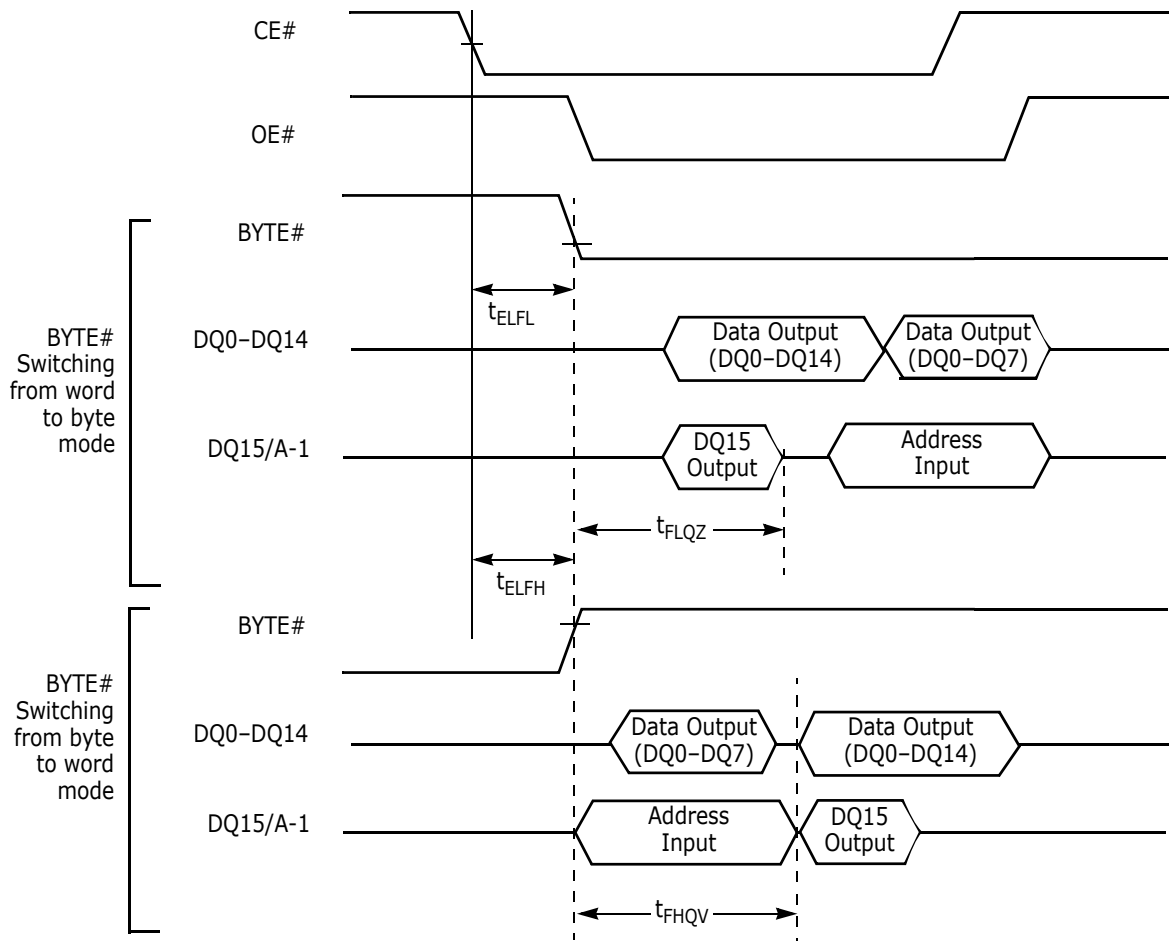
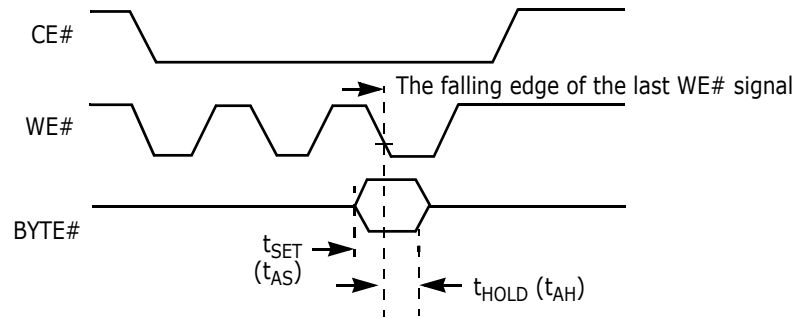

Figure 16. BYTE# Timings for Read Operations

AC Characteristics



Note: Refer to the Erase/Program Operations table for t_{AS} and t_{AH} specifications.

Figure 17. BYTE# Timings for Write Operations

Erase/Program Operations

Parameter		Description		Speed Options		Unit
JEDEC	Std			70	90	
t_{AVAV}	t_{WC}	Write Cycle Time (Note 1)	Min	70	90	ns
t_{AVWL}	t_{AS}	Address Setup Time	Min	0		ns
t_{WLAX}	t_{AH}	Address Hold Time	Min	45	45	ns
t_{DVWH}	t_{DS}	Data Setup Time	Min	35	45	ns
t_{WHDX}	t_{DH}	Data Hold Time	Min	0		ns
	t_{OES}	Output Enable Setup Time	Min	0		ns
t_{GHWL}	t_{GHWL}	Read Recovery Time Before Write (OE# High to WE# Low)	Min	0		ns
t_{ELWL}	t_{CS}	CE# Setup Time	Min	0		ns
t_{WHEH}	t_{CH}	CE# Hold Time	Min	0		ns
t_{WLWH}	t_{WP}	Write Pulse Width	Min	35	35	ns
t_{WHWL}	t_{WPH}	Write Pulse Width High	Min	30		ns
	$t_{SR/W}$	Latency Between Read and Write Operations	Min	20		ns
t_{WHWH1}	t_{WHWH1}	Programming Operation (Note 2)	Byte	Typ	9	μ s
			Word	Typ	11	
t_{WHWH1}	t_{WHWH1}	Accelerated Programming Operation, Word or Byte (Note 2)	Typ	7		μ s
t_{WHWH2}	t_{WHWH2}	Sector Erase Operation (Note 2)	Typ	0.7		sec
	t_{VCS}	V _{CC} Setup Time (Note 1)	Min	50		μ s
	t_{RB}	Recovery Time from RY/BY#	Min	0		ns
	t_{BUSY}	Program/Erase Valid to RY/BY# Delay	Max	90		ns

Notes:

1. Not 100% tested.
2. See [Erase and Programming Performance on page 61](#) for more information.

AC Characteristics

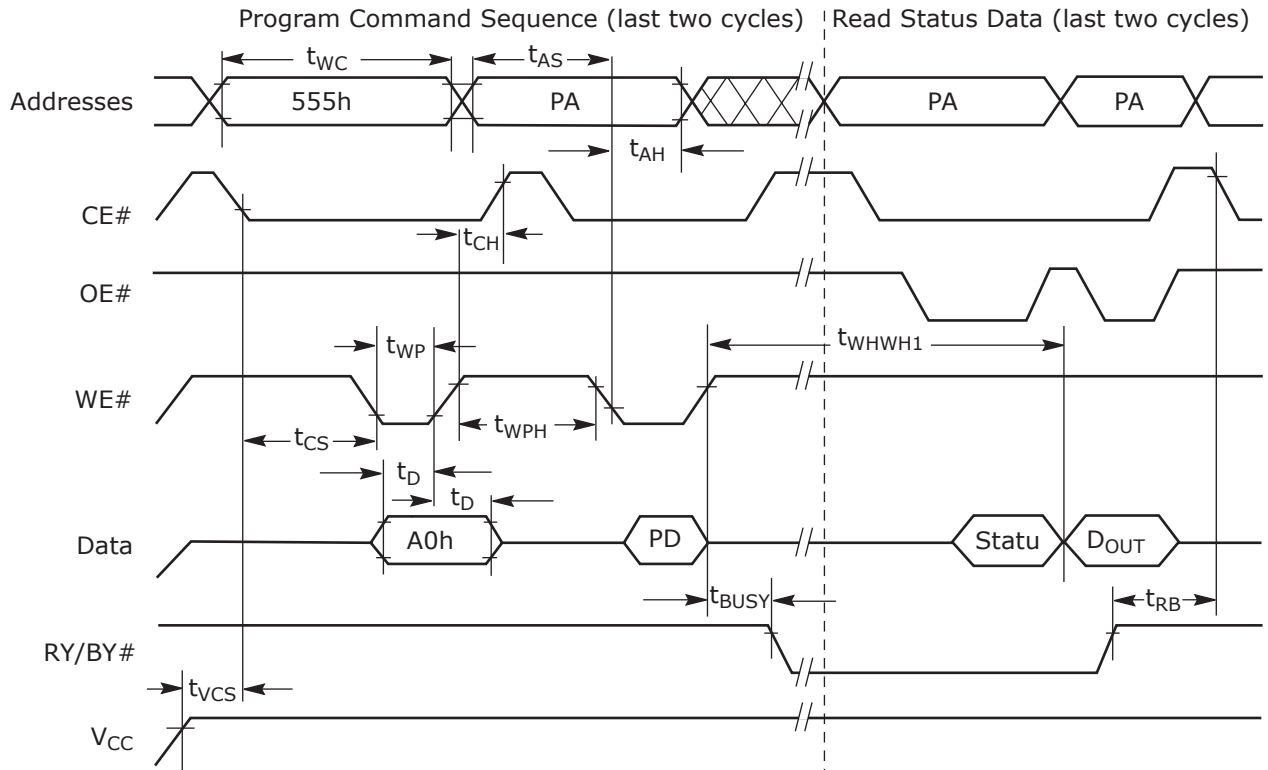

Notes:

1. PA = program address, PD = program data, D_{OUT} is the true data at the program address.
2. Illustration shows device in word mode.

Figure 18. Program Operation Timings

AC Characteristics

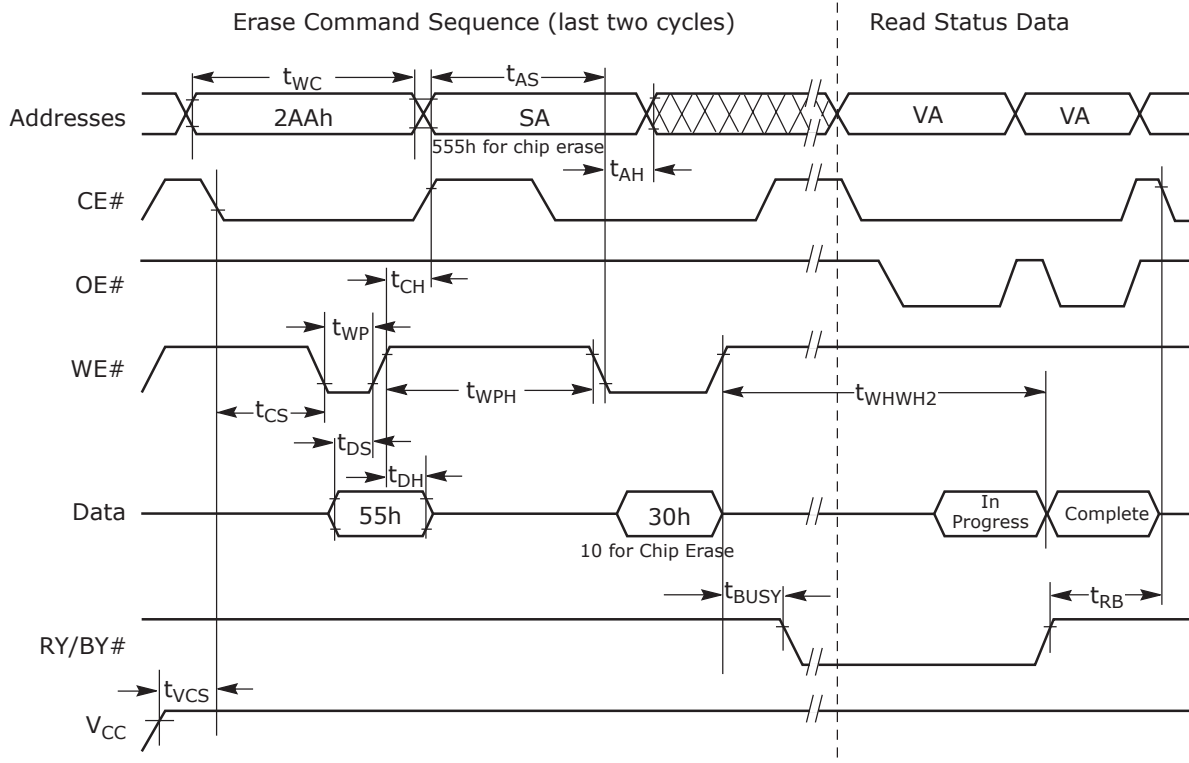

Notes:

1. SA = sector address (for Sector Erase), VA = Valid Address for reading status data (see [Write Operation Status on page 38](#)).
2. Illustration shows device in word mode.

Figure 19. Chip/Sector Erase Operation Timings

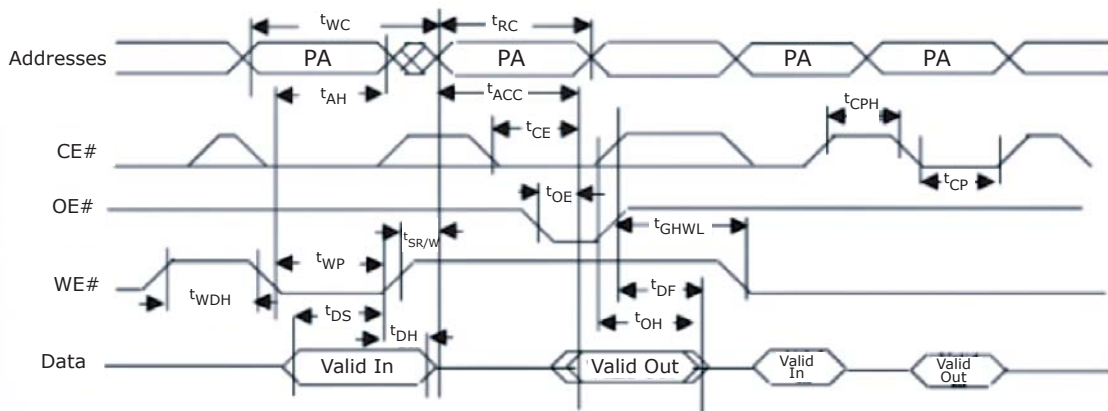
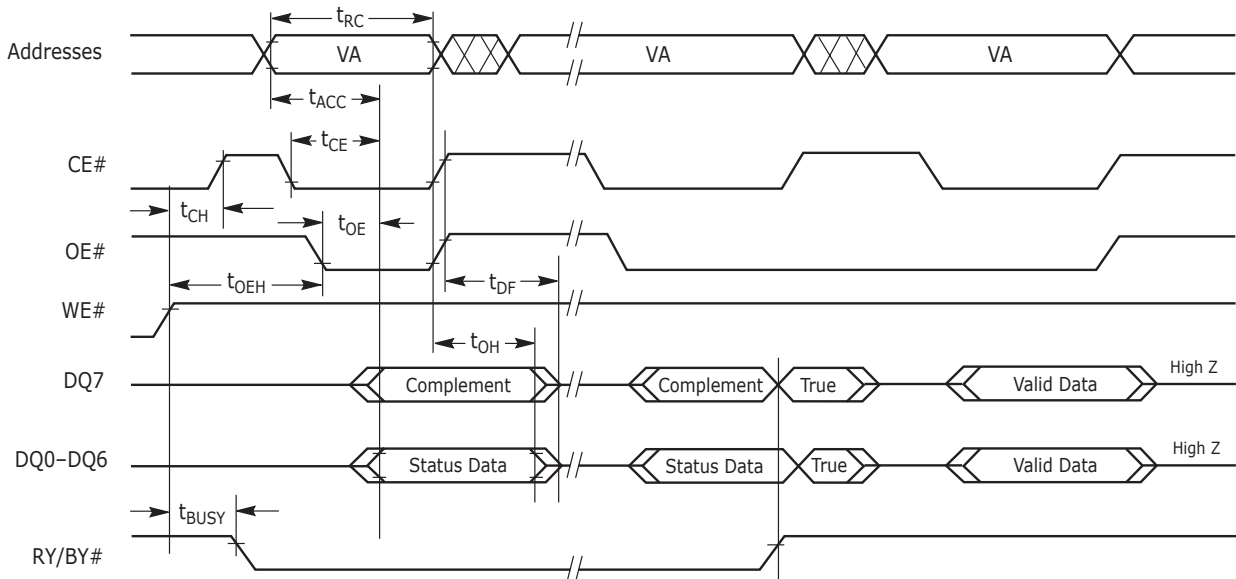

Figure 20. Back to Back Read/Write Cycle Timing

AC Characteristics



Note: VA = Valid address. Illustration shows first status cycle after command sequence, last status read cycle, and array data read cycle.

Figure 21. Data# Polling Timings (During Embedded Algorithms)

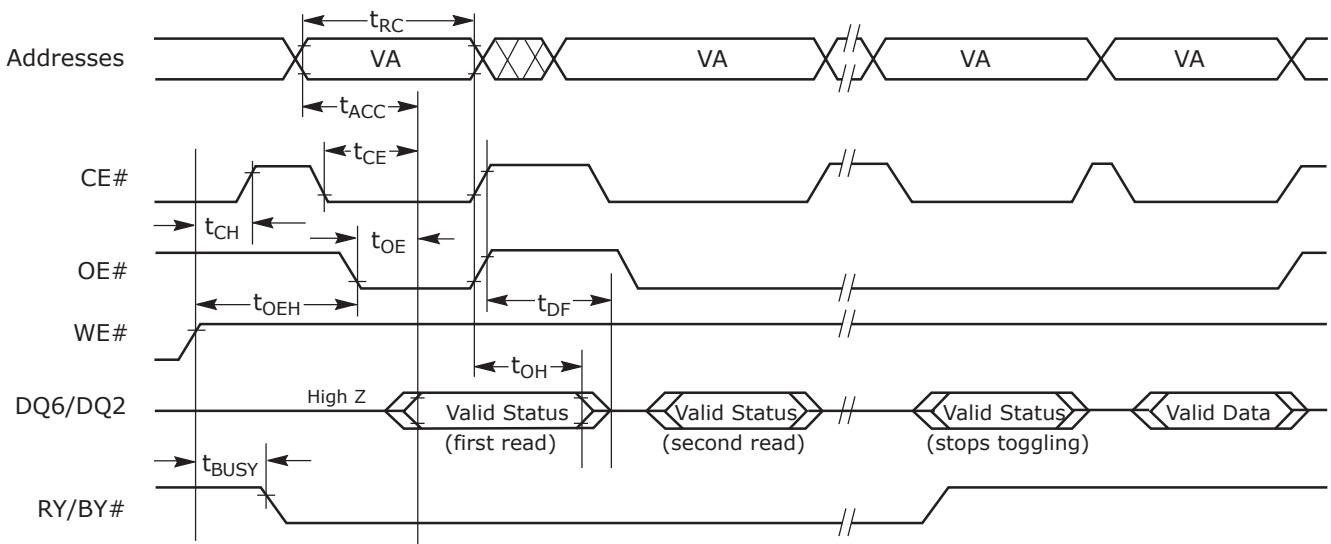

Note: VA = Valid address; not required for DQ6. Illustration shows first two status cycle after command sequence, last status read cycle, and array data read cycle.

Figure 22. Toggle Bit Timings (During Embedded Algorithms)

AC Characteristics

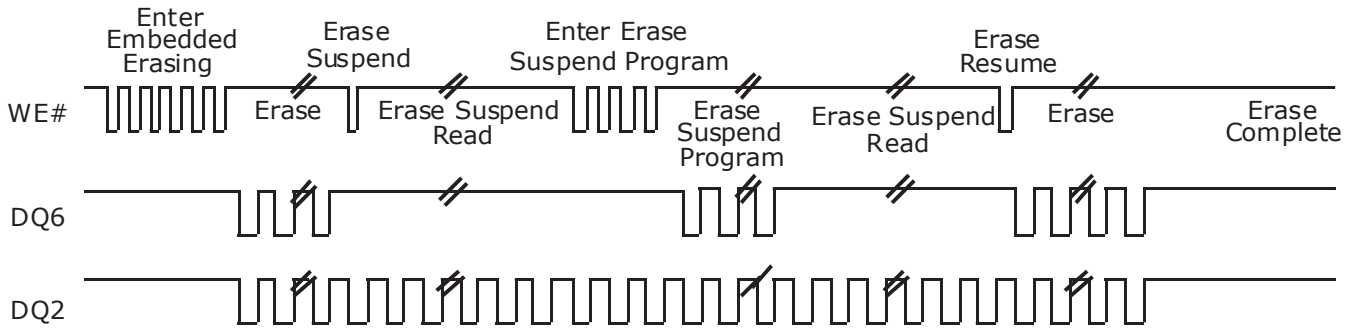

Note: The system may use CE# or OE# to toggle DQ2 and DQ6. DQ2 toggles only when read at an address within an erase-suspended sector.

Figure 23. DQ2 vs. DQ6 for Erase and Erase Suspend Operations

Temporary Sector Unprotect

Parameter		Description		All Speed Options	Unit
JEDEC	Std				
	t_{VIDR}	V_{ID} Rise and Fall Time (See Note)	Min	500	ns
	t_{RSP}	RESET# Setup Time for Temporary Sector Unprotect	Min	4	μ s

Note: Not 100% tested.

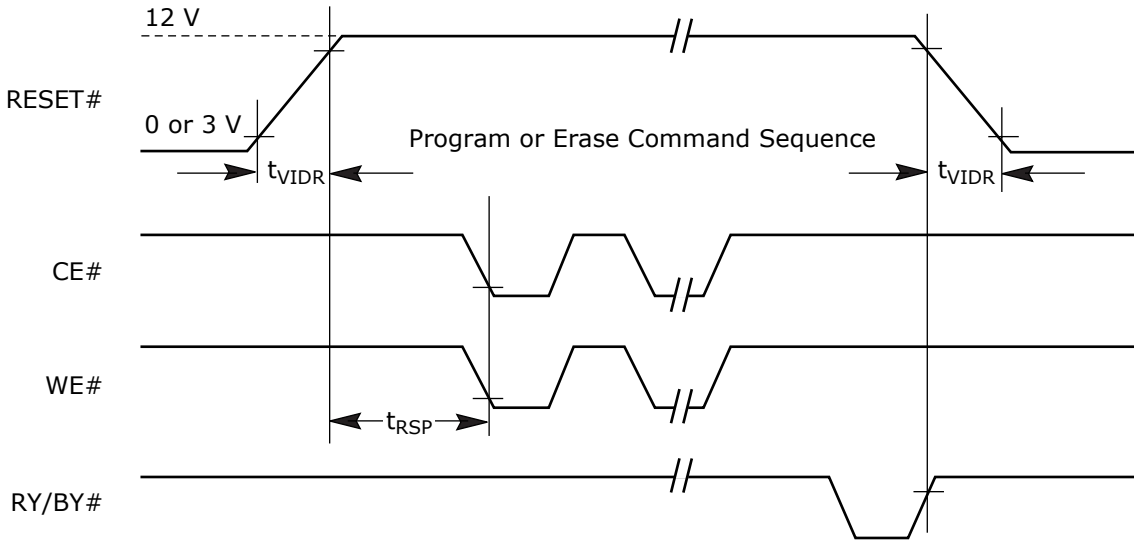

Figure 24. Temporary Sector Unprotect/Timing Diagram

AC Characteristics

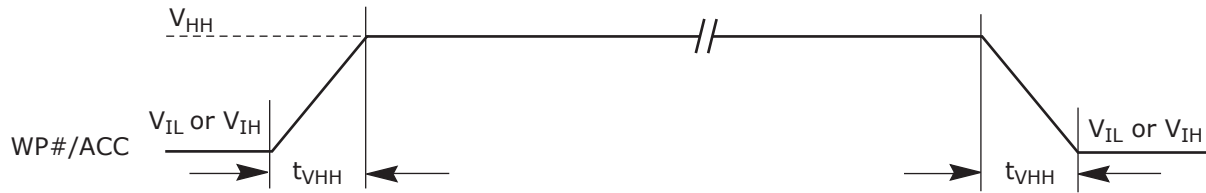
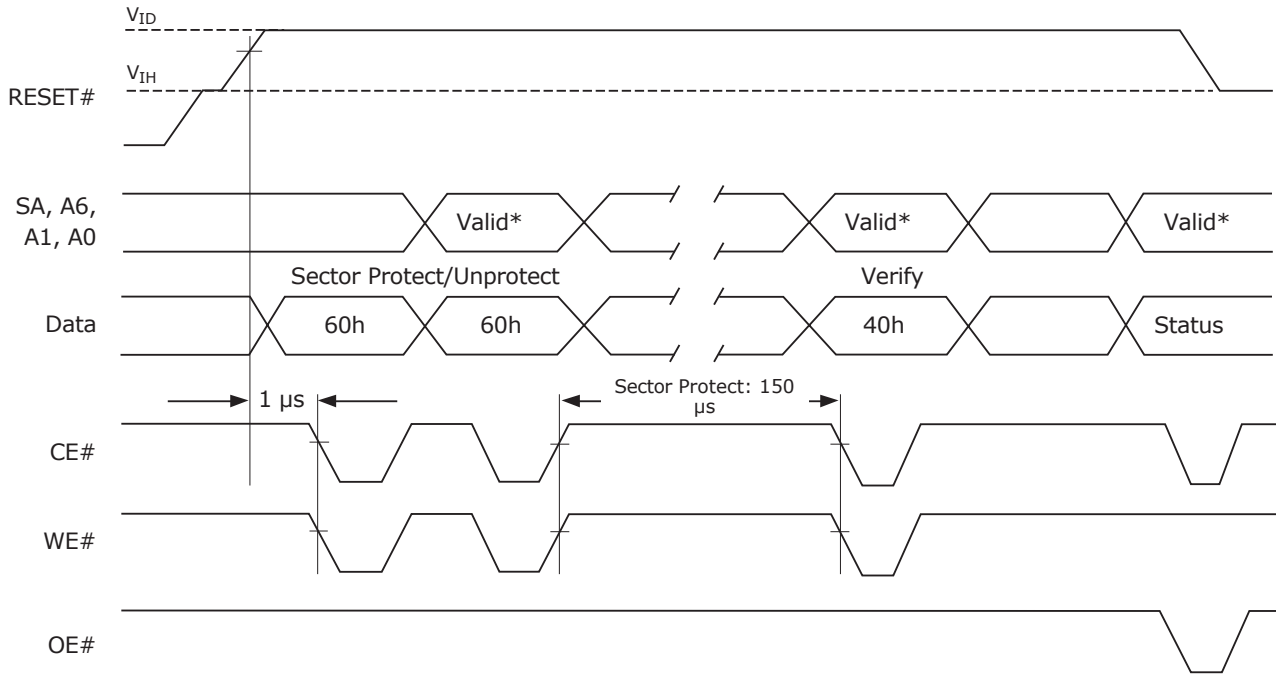

Figure 25. Accelerated Program Timing Diagram



Note: For sector protect, A6 = 0, A1 = 1, A0 = 0. For sector unprotect, A6 = 1, A1 = 1, A0 = 0.

Figure 26. Sector Protect/Unprotect Timing Diagram

AC Characteristics

Alternate CE# Controlled Erase/Program Operations

Parameter		Description		Speed Options		Unit
JEDEC	Std			70	90	
t_{AVAV}	t_{WC}	Write Cycle Time (Note 1)	Min	70	90	ns
t_{AVEL}	t_{AS}	Address Setup Time	Min	0		ns
t_{ELAX}	t_{AH}	Address Hold Time	Min	45	45	ns
t_{DVEH}	t_{DS}	Data Setup Time	Min	35	45	ns
t_{EHDX}	t_{DH}	Data Hold Time	Min	0		ns
	t_{OES}	Output Enable Setup Time	Min	0		ns
t_{GHEL}	t_{GHEL}	Read Recovery Time Before Write (OE# High to WE# Low)	Min	0		ns
t_{WLEL}	t_{WS}	WE# Setup Time	Min	0		ns
t_{EHWL}	t_{WH}	WE# Hold Time	Min	0		ns
t_{ELEH}	t_{CP}	CE# Pulse Width	Min	35	35	ns
t_{EHEL}	t_{CPH}	CE# Pulse Width High	Min	30		ns
	$t_{SR/W}$	Latency Between Read and Write Operations	Min	20		ns
t_{WHWH1}	t_{WHWH1}	Programming Operation (Note 2)	Byte	Typ	9	μ s
			Word	Typ	11	
t_{WHWH1}	t_{WHWH1}	Accelerated Programming Operation, Word or Byte (Note 2)	Typ	7		μ s
t_{WHWH2}	t_{WHWH2}	Sector Erase Operation (Note 2)	Typ	0.7		sec

Notes:

1. Not 100% tested.
2. See the [Erase and Programming Performance on page 61](#) section for more information.

AC Characteristics

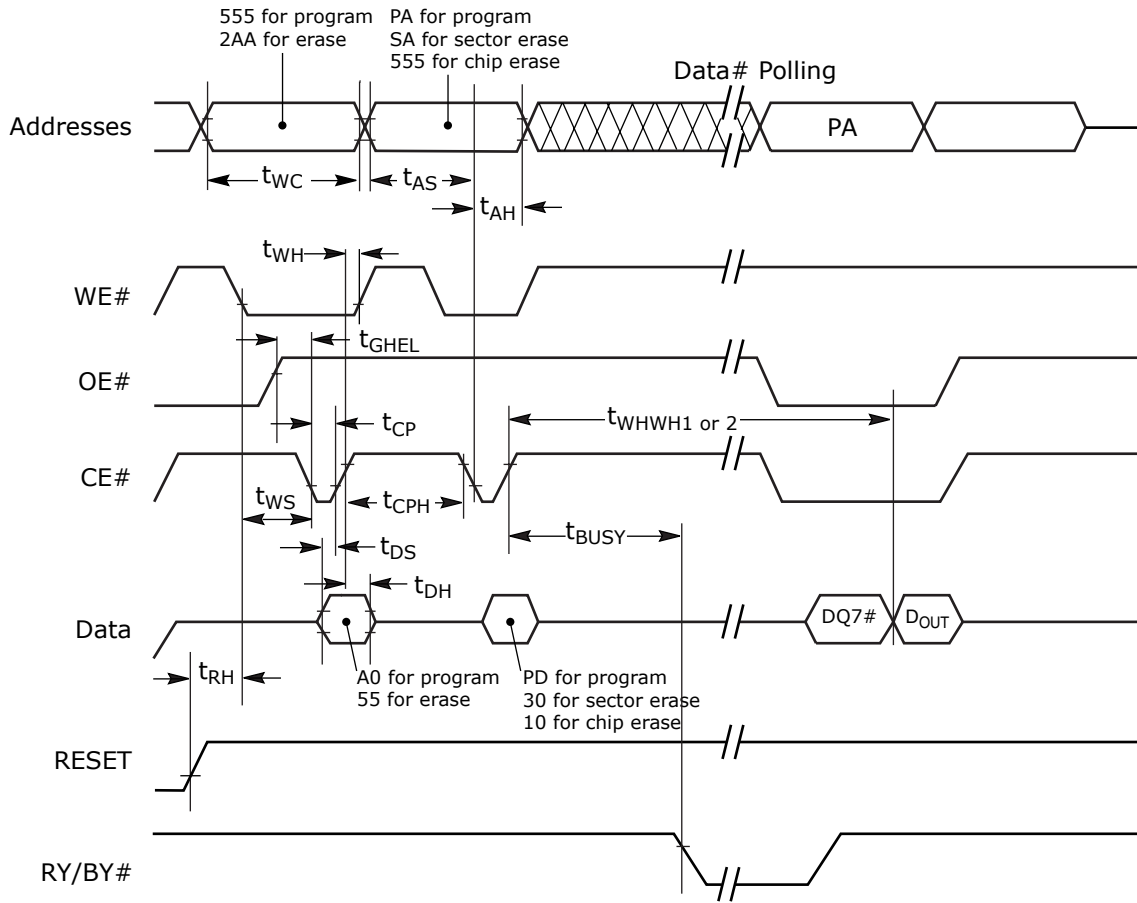

Notes:

1. PA = program address, PD = program data, DQ7# = complement of the data written to the device, D_{OUT} = data written to the device.
2. Figure indicates the last two bus cycles of the command sequence.
3. Word mode address used as an example.

Figure 27. Alternate CE# Controlled Write Operation Timings

Erase and Programming Performance

Parameter	Typ (Note 1)	Max (Note 2)	Unit	Comments	
Sector Erase Time (Note 7)	0.7	10	s	Excludes 00h programming prior to erasure (Note 4)	
Chip Erase Time (Note 8)	45		s		
Byte Programming Time	9	300	μs	Excludes system level overhead (Note 5)	
Word Programming Time	11	360	μs		
Accelerated Byte/Word Programming Time	7	210	μs		
Chip Programming Time (Note 3)	Byte Mode	36	108		s
	Word Mode	24	72		s

Notes:

1. Typical program and erase times assume the following conditions: 25°C, $V_{CC} = 3.0\text{ V}$, 100,000 cycles, checkerboard data pattern.
2. Under worst case conditions of 90°C, $V_{CC} = 2.7\text{ V}$, 1,000,000 cycles.
3. The typical chip programming time is considerably less than the maximum chip programming time listed, since most bytes program faster than the maximum program times listed.
4. In the pre-programming step of the Embedded Erase algorithm, all bytes are programmed to 00h before erasure.
5. System-level overhead is the time required to execute the two- or four-bus-cycle sequence for the program command. See Table 17 for further information on command definitions.
6. The device has a minimum erase and program cycle endurance of 100,000 cycles per sector.
7. At extended temperature range (>+85°C), typical erase time is 1.75 s and maximum erase time is 25 s.
8. At extended temperature range (>+85°C), typical erase time is 112 s.

TSOP and BGA Pin Capacitance

Parameter Symbol	Parameter Description	Test Setup	Package	Typ	Max	Unit
C_{IN}	Input Capacitance	$V_{IN} = 0$	TSOP	6	7.5	pF
			BGA	4.2	5.0	pF
C_{OUT}	Output Capacitance	$V_{OUT} = 0$	TSOP	8.5	12	pF
			BGA	5.4	6.5	pF
C_{IN2}	Control Pin Capacitance	$V_{IN} = 0$	TSOP	7.5	9	pF
			BGA	3.9	4.7	pF

Notes:

1. Sampled, not 100% tested.
2. Test conditions $T_A = 25^\circ\text{C}$, $f = 1.0\text{ MHz}$.

Physical Dimensions

TS040—40-Pin Standard TSOP

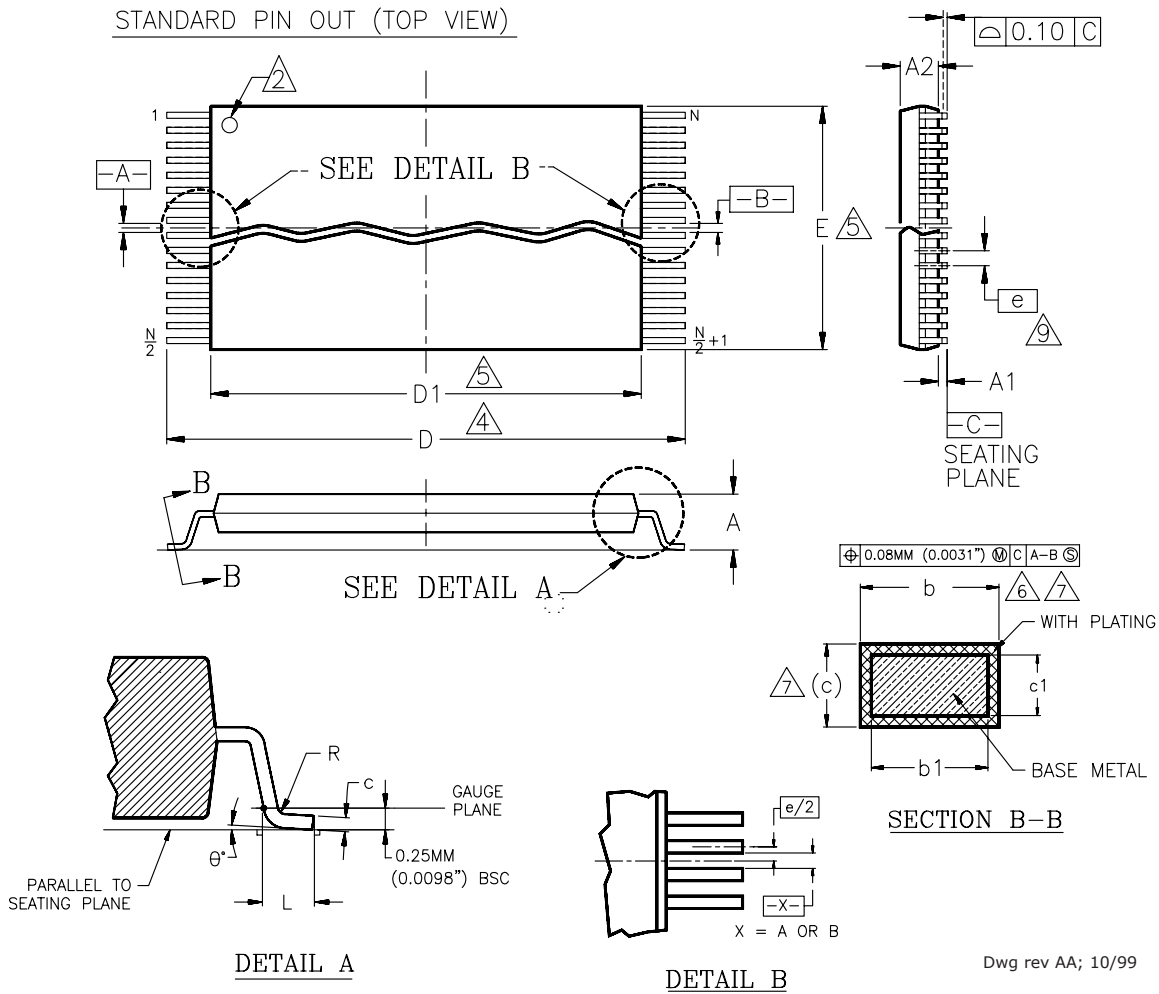

Dwg rev AA; 10/99

Package	TS 40		
Jedec	MO-142 (B) CD		
Symbol	MIN	NOM	MAX
A	—	—	1.20
A1	0.05	—	0.15
A2	0.95	1.00	1.05
b1	0.17	0.20	0.23
b	0.17	0.22	0.27
c1	0.10	—	0.16
c	0.10	—	0.21
D	19.80	20.00	20.20
D1	18.30	18.40	18.50
E	9.90	10.00	10.10
e	0.50 BASIC		
L	0.50	0.60	0.70
θ	0°	3°	5°
R	0.08	—	0.20
N	40		

NOTES:

1. CONTROLLING DIMENSIONS ARE IN MILLIMETERS (mm). DIMENSIONING AND TOLERANCING CONFORMS TO ANSI Y14.5M-1982.
2. PIN 1 IDENTIFIER FOR STANDARD PIN OUT (DIE UP).
3. PIN 1 IDENTIFIER FOR REVERSE PIN OUT (DIE DOWN): INK OR LASER MARK.
4. TO BE DETERMINED AT THE SEATING PLANE [-C-]. THE SEATING PLANE IS DEFINED AS THE PLANE OF CONTACT THAT IS MADE WHEN THE PACKAGE LEADS ARE ALLOWED TO REST FREELY ON A FLAT HORIZONTAL SURFACE.
5. DIMENSIONS D1 AND E DO NOT INCLUDE MOLD PROTRUSION. ALLOWABLE MOLD PROTRUSION IS 0.15mm (0.0059") PER SIDE.
6. DIMENSION b DOES NOT INCLUDE DAMBAR PROTRUSION. ALLOWABLE DAMBAR PROTRUSION SHALL BE 0.08mm (0.0031") TOTAL IN EXCESS OF b DIMENSION AT MAX. MATERIAL CONDITION. MINIMUM SPACE BETWEEN PROTRUSION AND AN ADJACENT LEAD TO BE 0.07mm (0.0028").
7. THESE DIMENSIONS APPLY TO THE FLAT SECTION OF THE LEAD BETWEEN 0.10mm (0.0039") AND 0.25mm (0.0098") FROM THE LEAD TIP.
8. LEAD COPLANARITY SHALL BE WITHIN 0.10mm (0.004") AS MEASURED FROM THE SEATING PLANE.
9. DIMENSION "e" IS MEASURED AT THE CENTERLINE OF THE LEADS.

Physical Dimensions

TS 048—48-Pin Standard TSOP

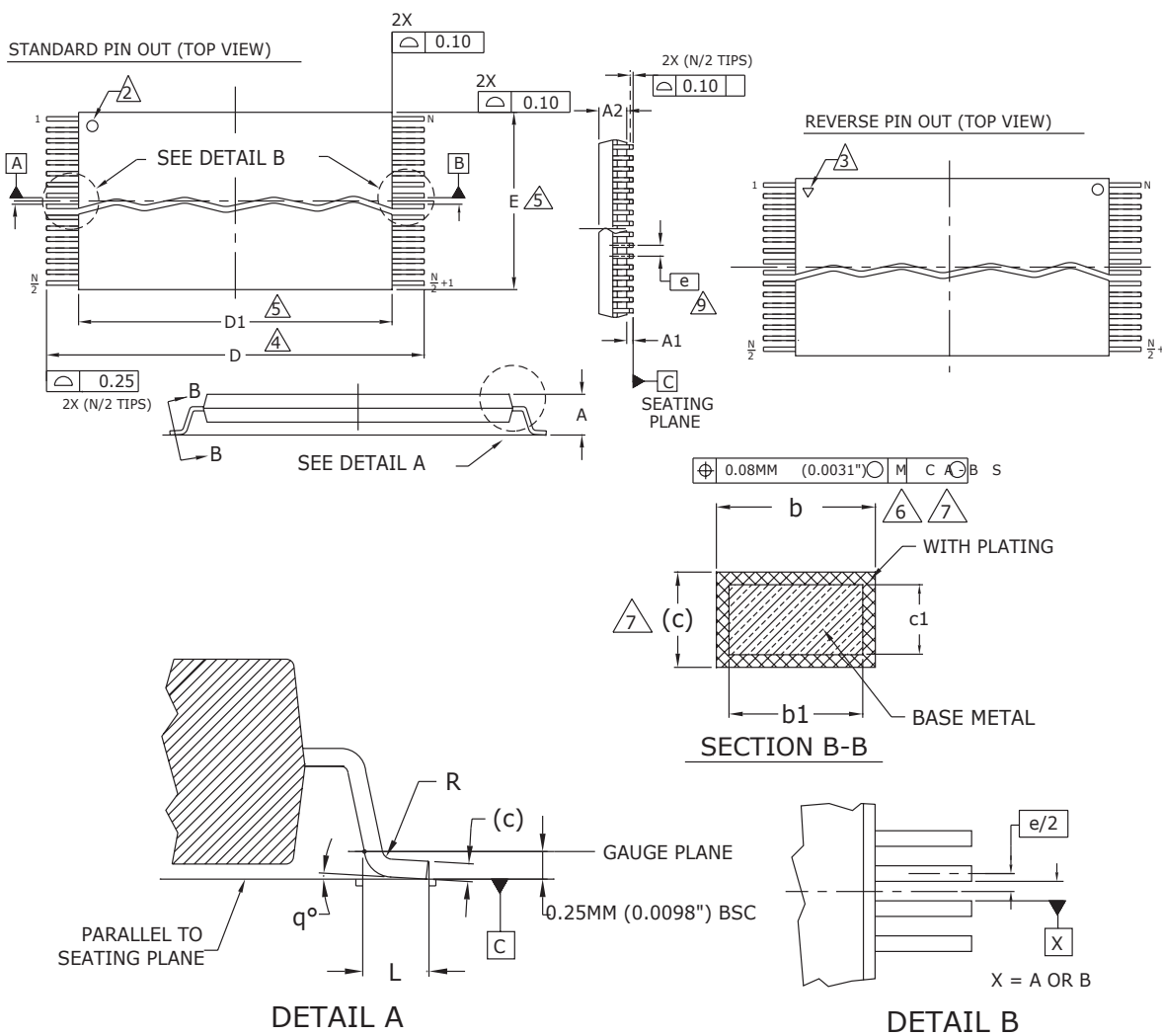

NOTES:

- ① CONTROLLING DIMENSIONS ARE IN MILLIMETERS (mm). (DIMENSIONING AND TOLERANCING CONFORMS TO ANSI Y14.5M-1982)
- ② PIN 1 IDENTIFIER FOR REVERSE PIN OUT (DIE UP).
- ③ PIN 1 IDENTIFIER FOR REVERSE PIN OUT (DIE DOWN), INK OR LASER MARK.
- ④ TO BE DETERMINED AT THE SEATING PLANE $\text{---}C$. THE SEATING PLANE IS DEFINED AS THE PLANE OF CONTACT THAT IS MADE WHEN THE PACKAGE LEADS ARE ALLOWED TO REST FREELY ON A FLAT HORIZONTAL SURFACE.
- ⑤ DIMENSIONS D1 AND E DO NOT INCLUDE MOLD PROTRUSION. ALLOWABLE MOLD PROTRUSION IS 0.15mm (.0059") PER SIDE.
- ⑥ DIMENSION b DOES NOT INCLUDE DAMBAR PROTRUSION. ALLOWABLE DAMBAR PROTRUSION SHALL BE 0.08 (0.0031") TOTAL IN EXCESS OF b DIMENSION AT MAX. MATERIAL CONDITION. MINIMUM SPACE BETWEEN PROTRUSION AND AN ADJACENT LEAD TO BE 0.07 (0.0028").
- ⑦ THESE DIMENSIONS APPLY TO THE FLAT SECTION OF THE LEAD BETWEEN 0.10MM (.0039") AND 0.25MM (0.0098") FROM THE LEAD TIP.
- ⑧ LEAD COPLANARITY SHALL BE WITHIN 0.10mm (0.004") AS MEASURED FROM THE SEATING PLANE.
- ⑨ DIMENSION "e" IS MEASURED AT THE CENTERLINE OF THE LEADS.

Jedec	MO-142 (D) DD		
Symbol	MIN	NOM	MAX
A	—	—	1.20
A1	0.05	—	0.15
A2	0.95	1.00	1.05
b1	0.17	0.20	0.23
b	0.17	0.22	0.27
c1	0.10	—	0.16
c	0.10	—	0.21
D	19.80	20.00	20.20
D1	18.30	18.40	18.50
E	11.90	12.00	12.10
e	0.50 BASIC		
L	0.50	0.60	0.70
θ	0°	—	8°
R	0.08	—	0.20
N	48		

3355 \ 16-038.10c

* For reference only. BSC is an ANSI standard for Basic Space Centering.

Physical Dimensions

VBN048—48-Ball Fine-Pitch Ball Grid Array (FBGA) 10.0 x 6.0 mm

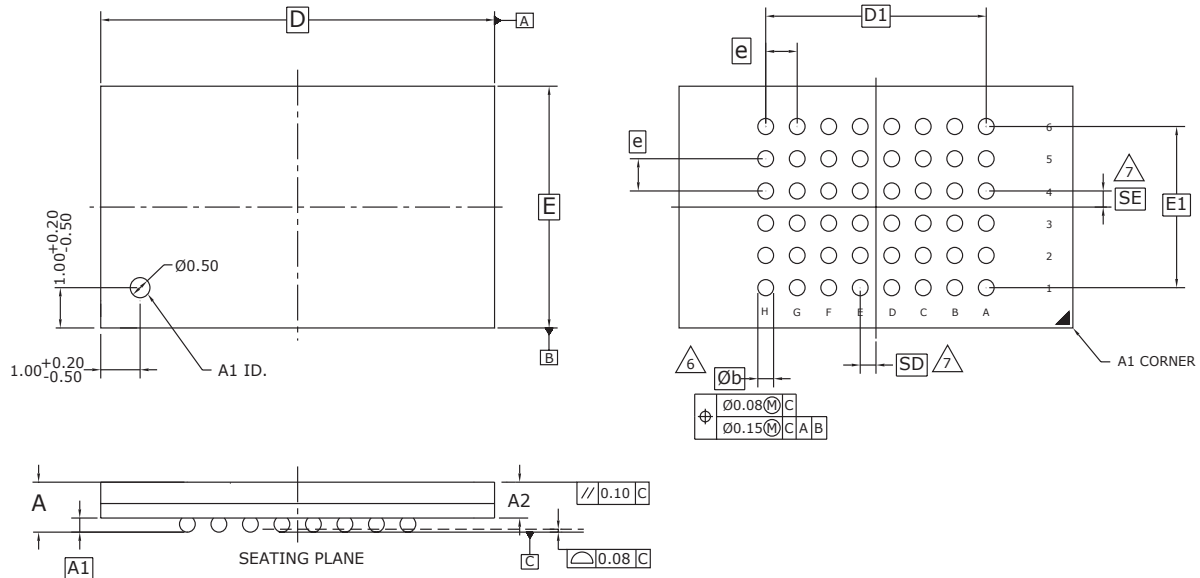

PACKAGE	VBN 048			
JEDEC	N/A			
	10.00 mm x 6.00 mm NOM PACKAGE			
SYMBOL	MIN	NOM	MAX	NOTE
A	---	---	1.00	OVERALL THICKNESS
A1	0.17	---	---	BALL HEIGHT
A2	0.62	---	0.73	BODY THICKNESS
D	10.00 BSC.			BODY SIZE
E	6.00 BSC.			BODY SIZE
D1	5.60 BSC.			BALL FOOTPRINT
E1	4.00 BSC.			BALL FOOTPRINT
MD	8			ROW MATRIX SIZE D DIRECTION
ME	6			ROW MATRIX SIZE E DIRECTION
N	48			TOTAL BALL COUNT
fb	0.35	---	0.45	BALL DIAMETER
e	0.80 BSC.			BALL PITCH
SD / SE	0.40 BSC.			SOLDER BALL PLACEMENT
	NONE			DEPOPULATED SOLDER BALLS

NOTES:

- DIMENSIONING AND TOLERANCING PER ASME Y14.5M-1994.
- ALL DIMENSIONS ARE IN MILLIMETERS.
- BALL POSITION DESIGNATION PER JESD 95-1, SPP-010 (EXCEPT AS NOTED).
- [e] REPRESENTS THE SOLDER BALL GRID PITCH.
- SYMBOL "MD" IS THE BALL ROW MATRIX SIZE IN THE "D" DIRECTION.
SYMBOL "ME" IS THE BALL COLUMN MATRIX SIZE IN THE "E" DIRECTION.
N IS THE TOTAL NUMBER OF SOLDER BALLS.
- [6] DIMENSION "b" IS MEASURED AT THE MAXIMUM BALL DIAMETER IN A PLANE PARALLEL TO DATUM C.
- [7] SD AND SE ARE MEASURED WITH RESPECT TO DATUMS A AND B AND DEFINE THE POSITION OF THE CENTER SOLDER BALL IN THE OUTER ROW.
WHEN THERE IS AN ODD NUMBER OF SOLDER BALLS IN THE OUTER ROW PARALLEL TO THE D OR E DIMENSION, RESPECTIVELY, SD OR SE = 0.000.
WHEN THERE IS AN EVEN NUMBER OF SOLDER BALLS IN THE OUTER ROW, SD OR SE = $\frac{e}{2}$
- NOT USED.
- "+" INDICATES THE THEORETICAL CENTER OF DEPOPULATED BALLS.
- [10] A1 CORNER TO BE IDENTIFIED BY CHAMFER, LASER OR INK MARK, METALLIZED MARK INDENTATION OR OTHER MEANS.

3425\ 16-038.25

Revision Summary

Revision A (January 31, 2005)

Initial Release.

Revision A1 (March 16, 2005)

Distinctive Characteristics

Revised Secured Silicon Sector with 128-word information

Common Flash Memory Interface — (CFI)

Modified Primary Vendor-Specific Extended Query table information for 45h address

Revision A2 (April 19, 2005)

Valid Combinations Table

Clarified available packing types for TSOP and FBGA packages

Modified note 1

Device Bus Operations

Added Secured Silicon Sector Addresses—Model 00 table

Modified Top Boot Secured Silicon Sector Addresses—Model 03 and Bottom Boot Secured Silicon Sector Addresses—Model 04 tables

S29AL032D Command Definitions Model 00 — table

Added Secured Silicon Sector Factory Protect information

Accelerated Program Operation

Added section

Write Protect (WP#) — Models 03, 04 Only

Added section

Secured Silicon Sector

Added section

AC Characteristics

Added ACC programming timing diagram

Revision A3 (June 13, 2005)

Autoselect Mode

Updated Table 8 to include models 00, 03, and 04.

Common Flash Memory Interface

Updated table headings in table 12, 13, 14, and 15.

Absolute Maximum Rating

Updated figure 8.

DC Characteristics

Updated CMOS Compatible table.

AC Characteristics

Updated Erase/Program Operations table.

Added new figure: *Back-to-Back Read/Write Cycle Timing*.

Updated Alternate CE# Controlled Erase/Program Operations table.

Revision A4 (July 29, 2005)

DS Status

Change of DS status to "Preliminary" from "Advance Information".

Output Disable Mode

Updated Model 00 Secured Silicon Sector Analysis table.

Autoselect Mode

Updated S29AL032D Autoselect Codes (High Voltage Method) table.

Revision A5 (September 21, 2005)

Corrected graphic in the figure "In-System Sector Protect/Unprotect Algorithms".

Revision A6 (May 22, 2006)

AC Characteristics

Added $t_{SR/W}$ parameter to read and erase/program operations tables. Added back-to-back read/write cycle timing diagram. Changed maximum value for t_{DF} and t_{FLQZ} .

Revision A7 (June 19, 2006)

Ordering Information

Added extended temperature range options to valid combinations.

Common Flash Memory Interface (CFI)

Primary Vendor-Specific Extended Query table: Change description for data at address 4Fh (address 9Eh on Models 03, 04).

DC Characteristics table

Changed Note 4.

Read Operations Timings figure

Connected end of t_{RC} period to start of t_{OH} period.

Erase and Programming Performance

Added Notes 7 and 8 to table.

Colophon

The products described in this document are designed, developed and manufactured as contemplated for general use, including without limitation, ordinary industrial use, general office use, personal use, and household use, but are not designed, developed and manufactured as contemplated (1) for any use that includes fatal risks or dangers that, unless extremely high safety is secured, could have a serious effect to the public, and could lead directly to death, personal injury, severe physical damage or other loss (i.e., nuclear reaction control in nuclear facility, aircraft flight control, air traffic control, mass transport control, medical life support system, missile launch control in weapon system), or (2) for any use where chance of failure is intolerable (i.e., submersible repeater and artificial satellite). Please note that Spansion LLC will not be liable to you and/or any third party for any claims or damages arising in connection with above-mentioned uses of the products. Any semiconductor devices have an inherent chance of failure. You must protect against injury, damage or loss from such failures by incorporating safety design measures into your facility and equipment such as redundancy, fire protection, and prevention of over-current levels and other abnormal operating conditions. If any products described in this document represent goods or technologies subject to certain restrictions on export under the Foreign Exchange and Foreign Trade Law of Japan, the US Export Administration Regulations or the applicable laws of any other country, the prior authorization by the respective government entity will be required for export of those products.

Trademarks and Notice

The contents of this document are subject to change without notice. This document may contain information on a Spansion LLC product under development by Spansion LLC. Spansion LLC reserves the right to change or discontinue work on any product without notice. The information in this document is provided as is without warranty or guarantee of any kind as to its accuracy, completeness, operability, fitness for particular purpose, merchantability, non-infringement of third-party rights, or any other warranty, express, implied, or statutory. Spansion LLC assumes no liability for any damages of any kind arising out of the use of the information in this document.

Copyright ©2004-2006 Spansion LLC. All rights reserved. Spansion, the Spansion logo, and MirrorBit are trademarks of Spansion LLC. Other company and product names used in this publication are for identification purposes only and may be trademarks of their respective companies.