



# 12-Bit, 8-Channel Sampling ANALOG-TO-DIGITAL CONVERTER with I<sup>2</sup>C Interface

## FEATURES

- EIGHT CHANNEL MULTIPLEXER
- 50kHz SAMPLING RATE
- NO MISSING CODES
- 2.7V TO 5V OPERATION
- INTERNAL 2.5V REFERENCE
- I<sup>2</sup>C INTERFACE SUPPORTS:  
Standard, Fast, and High-Speed Modes
- TSSOP-16 PACKAGE

## DESCRIPTION

The ADS7828 is a single-supply, low-power, 12-bit data acquisition device that features a serial I<sup>2</sup>C interface and an 8-channel multiplexer. The Analog-to-Digital (A/D) converter features a sample-and-hold amplifier and internal, asynchronous clock. The combination of an I<sup>2</sup>C serial, two-wire interface and micropower consumption makes the ADS7828 ideal for applications requiring the A/D converter to be close to the input source in remote locations and for applications requiring isolation. The ADS7828 is available in a TSSOP-16.

## APPLICATIONS

- VOLTAGE-SUPPLY MONITORING
- ISOLATED DATA ACQUISITION
- TRANSDUCER INTERFACE
- BATTERY-OPERATED SYSTEMS
- REMOTE DATA ACQUISITION

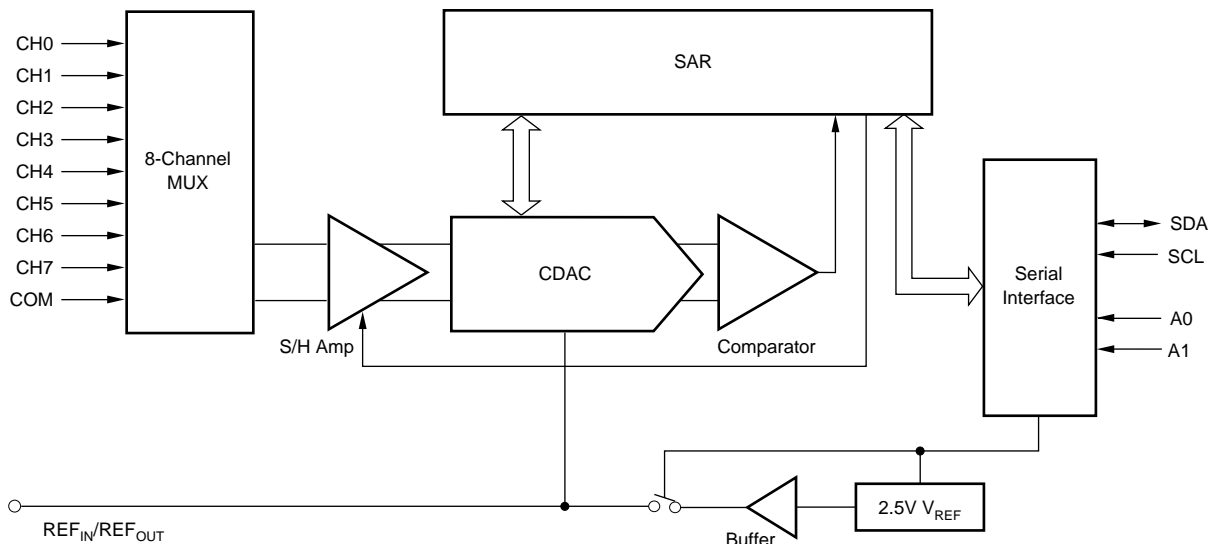

Please be aware that an important notice concerning availability, standard warranty, and use in critical applications of Texas Instruments semiconductor products and disclaimers thereto appears at the end of this data sheet.

## ABSOLUTE MAXIMUM RATINGS<sup>(1)</sup>

+V <sub>DD</sub> to GND	-0.3V to +6V
Digital Input Voltage to GND	-0.3V to +V <sub>DD</sub> + 0.3V
Operating Temperature Range	-40°C to +105°C
Storage Temperature Range	-65°C to +150°C
Junction Temperature (T <sub>J</sub> max)	+150°C
TSSOP Package	
Power Dissipation	(T <sub>J</sub> max - T <sub>A</sub> )/θ <sub>JA</sub>
θ <sub>JA</sub> Thermal Impedance	240°C/W
Lead Temperature, Soldering	
Vapor Phase (60s)	+215°C
Infrared (15s)	+220°C

NOTE: (1) Stresses above those listed under "Absolute Maximum Ratings" may cause permanent damage to the device. Exposure to absolute maximum conditions for extended periods may affect device reliability.



## ELECTROSTATIC DISCHARGE SENSITIVITY

This integrated circuit can be damaged by ESD. Texas Instruments recommends that all integrated circuits be handled with appropriate precautions. Failure to observe proper handling and installation procedures can cause damage.

ESD damage can range from subtle performance degradation to complete device failure. Precision integrated circuits may be more susceptible to damage because very small parametric changes could cause the device not to meet its published specifications.

## PACKAGE/ORDERING INFORMATION

PRODUCT	MAXIMUM INTEGRAL LINEARITY ERROR (LSB)	PACKAGE-LEAD	PACKAGE DESIGNATOR <sup>(1)</sup>	SPECIFIED TEMPERATURE RANGE	ORDERING NUMBER <sup>(2)</sup>	TRANSPORT MEDIA, QUANTITY
ADS7828E	±2	TSSOP-16	PW	-40°C to +85°C	ADS7828E/250	Tape and Reel, 250
"	"	"	"	"	ADS7828E/2K5	Tape and Reel, 2500
ADS7828EB	±1	TSSOP-16	PW	-40°C to +85°C	ADS7828EB/250	Tape and Reel, 250
"	"	"	"	"	ADS7828EB/2K5	Tape and Reel, 2500

NOTES: (1) For the most current specifications and package information, refer to our web site at [www.ti.com](http://www.ti.com). (2) Models with a slash (/) are available only in Tape and Reel in the quantities indicated (e.g., /2K5 indicates 2500 devices per reel). Ordering 2500 pieces of "ADS7828E/2K5" will get a single 2500-piece Tape and Reel.

## ELECTRICAL CHARACTERISTICS: +2.7V

At T<sub>A</sub> = -40°C to +85°C, +V<sub>DD</sub> = +2.7V, V<sub>REF</sub> = +2.5V, SCL Clock Frequency = 3.4MHz (High-Speed Mode), unless otherwise noted.

PARAMETER	CONDITIONS	ADS7828E			ADS7828EB			UNITS
		MIN	TYP	MAX	MIN	TYP	MAX	
<b>ANALOG INPUT</b>								
Full-Scale Input Scan	Positive Input - Negative Input	0		V <sub>REF</sub>	*		*	V
Absolute Input Range	Positive Input	-0.2		+V <sub>DD</sub> + 0.2	*		*	V
	Negative Input	-0.2		+0.2	*		*	V
Capacitance			25			*		pF
Leakage Current			±1			*		µA
<b>SYSTEM PERFORMANCE</b>								
No Missing Codes		12			*			Bits
Integral Linearity Error			±1.0	±2		±0.5	±1	LSB <sup>(1)</sup>
Differential Linearity Error			±1.0			±0.5	-1, +2	LSB
Offset Error			±1.0	±3		±0.75	±2	LSB
Offset Error Match			±0.2	±1		*	*	LSB
Gain Error			±1.0	±4		±0.75	±3	LSB
Gain Error Match			±0.2	±1		*	*	LSB
Noise			33			*		µVrms
Power-Supply Rejection			82			*		dB
<b>SAMPLING DYNAMICS</b>								
Throughput Frequency	High Speed Mode: SCL = 3.4MHz Fast Mode: SCL = 400kHz Standard Mode, SCL = 100kHz			50 8 2			*	kHz
Conversion Time			6			*		kHz µs
<b>AC ACCURACY</b>								
Total Harmonic Distortion	V <sub>IN</sub> = 2.5Vp-p at 10kHz		-82			*		dB <sup>(2)</sup>
Signal-to-Ratio	V <sub>IN</sub> = 2.5Vp-p at 10kHz		72			*		dB
Signal-to-(Noise+Distortion) Ratio	V <sub>IN</sub> = 2.5Vp-p at 10kHz		71			*		dB
Spurious-Free Dynamic Range	V <sub>IN</sub> = 2.5Vp-p at 10kHz		86			*		dB
Isolation Channel-to-Channel			120			*		dB
<b>VOLTAGE REFERENCE OUTPUT</b>								
Range		2.475	2.5	2.525	*	*	*	V
Internal Reference Drift			15			*		ppm/°C
Output Impedance	Internal Reference ON		110			*		Ω
	Internal Reference OFF		1			*		GΩ
Quiescent Current	Int. Ref. ON, SCL and SDA pulled HIGH		850			*		µA
<b>VOLTAGE REFERENCE INPUT</b>								
Range		0.05		V <sub>DD</sub>	*		*	V
Resistance			1			*		GΩ
Current Drain	High Speed Mode: SCL= 3.4MHz		20			*		µA

# ELECTRICAL CHARACTERISTICS: +2.7V (Cont.)

At  $T_A = -40^{\circ}\text{C}$  to  $+85^{\circ}\text{C}$ ,  $+V_{DD} = +2.7\text{V}$ ,  $V_{REF} = +2.5\text{V}$ , SCL Clock Frequency = 3.4MHz (High-Speed Mode), unless otherwise noted.

PARAMETER	CONDITIONS	ADS7828E			ADS7828EB			UNITS
		MIN	TYP	MAX	MIN	TYP	MAX	
<b>DIGITAL INPUT/OUTPUT</b>								
Logic Family			CMOS			*	*	V
Logic Levels: $V_{IH}$		$+V_{DD} \cdot 0.7$		$+V_{DD} + 0.5$	*		*	V
$V_{IL}$		-0.3		$+V_{DD} \cdot 0.3$	*		*	V
$V_{OL}$				0.4			*	V
Input Leakage: $I_{IH}$	Min. 3mA Sink Current			10			*	$\mu\text{A}$
$I_{IL}$	$V_{IH} = +V_{DD} + 0.5$				*		*	$\mu\text{A}$
Data Format	$V_{IL} = -0.3$	-10	Straight Binary			*		
<b>ADS7828 HARDWARE ADDRESS</b>			10010			*		Binary
<b>POWER-SUPPLY REQUIREMENTS</b>								
Power-Supply Voltage, $+V_{DD}$	Specified Performance	2.7		3.6	*		*	V
Quiescent Current	High Speed Mode: SCL = 3.4MHz		225	320		*	*	$\mu\text{A}$
	Fast Mode: SCL = 400kHz		100			*		$\mu\text{A}$
	Standard Mode, SCL = 100kHz		60			*		$\mu\text{A}$
Power Dissipation	High Speed Mode: SCL = 3.4MHz		675	1000		*	*	$\mu\text{W}$
	Fast Mode: SCL = 400kHz		300			*		$\mu\text{W}$
	Standard Mode, SCL = 100kHz		180			*		$\mu\text{W}$
Power-Down Mode	High Speed Mode: SCL = 3.4MHz		70			*		$\mu\text{A}$
w/Wrong Address Selected	Fast Mode: SCL = 400kHz		25			*		$\mu\text{A}$
	Standard Mode, SCL = 100kHz		6			*		$\mu\text{A}$
Full Power-Down	SCL Pulled HIGH, SDA Pulled HIGH		400	3000		*	*	nA
<b>TEMPERATURE RANGE</b>								
Specified Performance		-40		85	*		*	$^{\circ}\text{C}$

\* Specifications same as ADS7828E.

NOTES: (1) LSB means Least Significant Bit. With  $V_{REF}$  equal to 2.5V, 1LSB is 610 $\mu\text{V}$ . (2) THD measured out to the 9th-harmonic.

# ELECTRICAL CHARACTERISTICS: +5V

At  $T_A = -40^{\circ}\text{C}$  to  $+85^{\circ}\text{C}$ ,  $+V_{DD} = +5.0\text{V}$ ,  $V_{REF} = \text{External } +5.0\text{V}$ , SCL Clock Frequency = 3.4MHz (High-Speed Mode), unless otherwise noted.

PARAMETER	CONDITIONS	ADS7828E			ADS7828EB			UNITS
		MIN	TYP	MAX	MIN	TYP	MAX	
<b>ANALOG INPUT</b>								
Full-Scale Input Scan	Positive Input - Negative Input	0		$V_{REF}$	*		*	V
Absolute Input Range	Positive Input	-0.2		$+V_{DD} + 0.2$	*		*	V
	Negative Input	-0.2		+0.2	*		*	V
Capacitance			25			*		pF
Leakage Current			$\pm 1$			*		$\mu\text{A}$
<b>SYSTEM PERFORMANCE</b>								
No Missing Codes		12			*			Bits
Integral Linearity Error			$\pm 1.0$	$\pm 2$		$\pm 0.5$	$\pm 1$	LSB <sup>(1)</sup>
Differential Linearity Error			$\pm 1.0$			$\pm 0.5$	-1, +2	LSB
Offset Error			$\pm 1.0$	$\pm 3$		$\pm 0.75$	$\pm 2$	LSB
Offset Error Match				$\pm 1$			*	LSB
Gain Error			$\pm 1.0$	$\pm 3$		$\pm 0.75$	$\pm 2$	LSB
Gain Error Match				$\pm 1$			*	LSB
Noise			33			*		$\mu\text{V}_{\text{rms}}$
Power-Supply Rejection			82			*		dB
<b>SAMPLING DYNAMICS</b>								
Throughput Frequency	High Speed Mode: SCL = 3.4MHz			50			*	kHz
	Fast Mode: SCL = 400kHz			8			*	kHz
	Standard Mode, SCL = 100kHz			2			*	kHz
Conversion Time			6			*		$\mu\text{s}$
<b>AC ACCURACY</b>								
Total Harmonic Distortion	$V_{IN} = 2.5\text{Vp-p}$ at 10kHz		-82			*		dB <sup>(2)</sup>
Signal-to-Ratio	$V_{IN} = 2.5\text{Vp-p}$ at 10kHz		72			*		dB
Signal-to-(Noise+Distortion) Ratio	$V_{IN} = 2.5\text{Vp-p}$ at 10kHz		71			*		dB
Spurious-Free Dynamic Range	$V_{IN} = 2.5\text{Vp-p}$ at 10kHz		86			*		dB
Isolation Channel-to-Channel			120			*		dB
<b>VOLTAGE REFERENCE OUTPUT</b>								
Range		2.475	2.5	2.525	*	*	*	V
Internal Reference Drift			15					$\text{ppm}/^{\circ}\text{C}$
Output Impedance	Internal Reference ON		110			*		$\Omega$
	Internal Reference OFF		1			*		$\text{G}\Omega$
Quiescent Current	Int. Ref. ON, SCL and SDA pulled HIGH		1300			*		$\mu\text{A}$
<b>VOLTAGE REFERENCE INPUT</b>								
Range		0.05		$V_{DD}$	*		*	V
Resistance			1			*		$\text{G}\Omega$
Current Drain	High Speed Mode: SCL = 3.4MHz		20			*		$\mu\text{A}$

# ELECTRICAL CHARACTERISTICS: +5V (Cont.)

At  $T_A = -40^{\circ}\text{C}$  to  $+85^{\circ}\text{C}$ ,  $+V_{DD} = +5.0\text{V}$ ,  $V_{REF} = \text{External } +5.0\text{V}$ , SCL Clock Frequency = 3.4MHz (High-Speed Mode), unless otherwise noted.

PARAMETER	CONDITIONS	ADS7828E			ADS7828EB			UNITS
		MIN	TYP	MAX	MIN	TYP	MAX	
<b>DIGITAL INPUT/OUTPUT</b>								
Logic Family		CMOS			*			
Logic Levels: $V_{IH}$		$+V_{DD} \cdot 0.7$		$+V_{DD} + 0.5$	*		*	V
$V_{IL}$		-0.3		$+V_{DD} \cdot 0.3$	*		*	V
$V_{OL}$	Min. 3mA Sink Current			0.4			*	V
Input Leakage: $I_{IH}$	$V_{IH} = +V_{DD} + 0.5$			10			*	$\mu\text{A}$
$I_{IL}$	$V_{IL} = -0.3$	-10			*		*	$\mu\text{A}$
Data Format			Straight Binary		*			
<b>ADS7828 HARDWARE ADDRESS</b>			10010		*			Binary
<b>POWER-SUPPLY REQUIREMENTS</b>								
Power-Supply Voltage, $+V_{DD}$	Specified Performance	4.75	5	5.25	*		*	V
Quiescent Current	High Speed Mode: SCL = 3.4MHz		750	1000		*	*	$\mu\text{A}$
	Fast Mode: SCL = 400kHz		300			*		$\mu\text{A}$
	Standard Mode, SCL = 100kHz		150			*		$\mu\text{A}$
Power Dissipation	High Speed Mode: SCL = 3.4MHz		3.75	5		*	*	mW
	Fast Mode: SCL = 400kHz		1.5			*		mW
	Standard Mode, SCL = 100kHz		0.75			*		mW
Power-Down Mode	High Speed Mode: SCL = 3.4MHz		400			*		$\mu\text{A}$
w/Wrong Address Selected	Fast Mode: SCL = 400kHz		150			*		$\mu\text{A}$
	Standard Mode, SCL = 100kHz		35			*		$\mu\text{A}$
Full Power-Down	SCL Pulled HIGH, SDA Pulled HIGH		400	3000		*	*	nA
<b>TEMPERATURE RANGE</b>								
Specified Performance		-40		85	*		*	$^{\circ}\text{C}$

\* Specifications same as ADS7828E.

NOTES: (1) LSB means Least Significant Bit. With  $V_{REF}$  equal to 5.0V, 1LSB is 1.22mV. (2) THD measured out to the 9th-harmonic.

## PIN CONFIGURATION

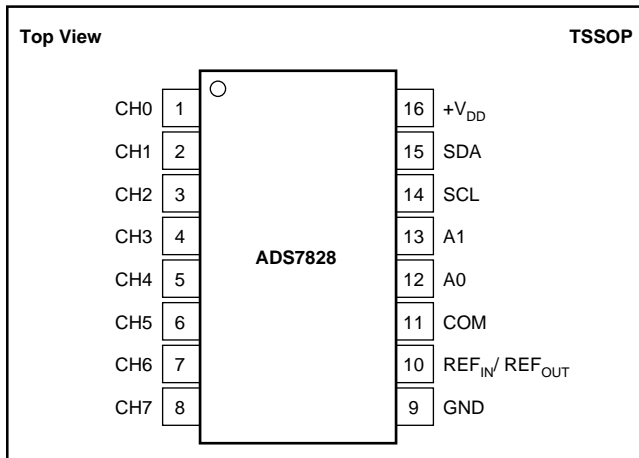

## PIN DESCRIPTIONS

PIN	NAME	DESCRIPTION
1	CH0	Analog Input Channel 0
2	CH1	Analog Input Channel 1
3	CH2	Analog Input Channel 2
4	CH3	Analog Input Channel 3
5	CH4	Analog Input Channel 4
6	CH5	Analog Input Channel 5
7	CH6	Analog Input Channel 6
8	CH7	Analog Input Channel 7
9	GND	Analog Ground
10	REF <sub>IN</sub> / REF <sub>OUT</sub>	Internal +2.5V Reference, External Reference Input
11	COM	Common to Analog Input Channel
12	A0	Slave Address Bit 0
13	A1	Slave Address Bit 1
14	SCL	Serial Clock
15	SDA	Serial Data
16	+V <sub>DD</sub>	Power Supply, 3.3V Nominal

## TIMING DIAGRAM

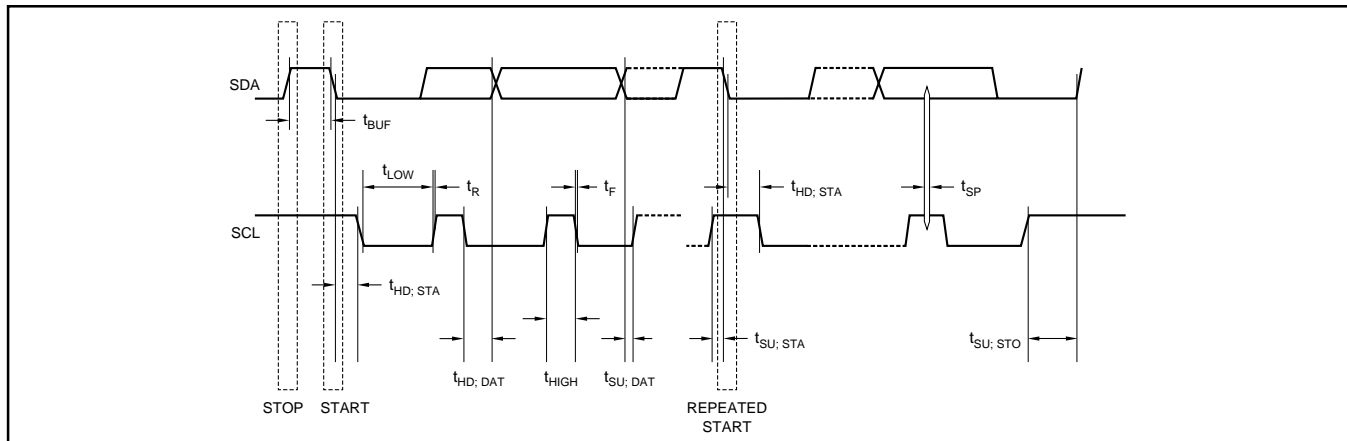

# TIMING CHARACTERISTICS<sup>(1)</sup>

At  $T_A = -40^{\circ}\text{C}$  to  $+85^{\circ}\text{C}$ ,  $+V_{DD} = +2.7\text{V}$ , unless otherwise noted.

PARAMETER	SYMBOL	CONDITIONS	MIN	MAX	UNITS
SCL Clock Frequency	$f_{\text{SCL}}$	Standard Mode Fast Mode High-Speed Mode, $C_B = 100\text{pF}$ max High-Speed Mode, $C_B = 400\text{pF}$ max		100 400 3.4 1.7	kHz kHz MHz MHz
Bus Free Time Between a STOP and START Condition	$t_{\text{BUF}}$	Standard Mode Fast Mode	4.7 1.3		$\mu\text{s}$ $\mu\text{s}$
Hold Time (Repeated) START Condition	$t_{\text{HD:STA}}$	Standard Mode Fast Mode High-Speed Mode	4.0 600 160		$\mu\text{s}$ ns ns
LOW Period of the SCL Clock	$t_{\text{LOW}}$	Standard Mode Fast Mode High-Speed Mode, $C_B = 100\text{pF}$ max <sup>(2)</sup> High-Speed Mode, $C_B = 400\text{pF}$ max <sup>(2)</sup>	4.7 1.3 160 320		$\mu\text{s}$ $\mu\text{s}$ ns ns
HIGH Period of the SCL Clock	$t_{\text{HIGH}}$	Standard Mode Fast Mode High-Speed Mode, $C_B = 100\text{pF}$ max <sup>(2)</sup> High-Speed Mode, $C_B = 400\text{pF}$ max <sup>(2)</sup>	4.0 600 60 120		$\mu\text{s}$ ns ns ns
Setup Time for a Repeated START Condition	$t_{\text{SU:STA}}$	Standard Mode Fast Mode High-Speed Mode	4.7 600 160		$\mu\text{s}$ ns ns
Data Setup Time	$t_{\text{SU:DAT}}$	Standard Mode Fast Mode High-Speed Mode	250 100 10		ns ns ns
Data Hold Time	$t_{\text{HD:DAT}}$	Standard Mode Fast Mode High-Speed Mode, $C_B = 100\text{pF}$ max <sup>(2)</sup> High-Speed Mode, $C_B = 400\text{pF}$ max <sup>(2)</sup>	0 0 0 <sup>(3)</sup> 0 <sup>(3)</sup>	0.9 0.9 70 150	$\mu\text{s}$ $\mu\text{s}$ ns ns
Rise Time of SCL Signal	$t_{\text{RCL}}$	Standard Mode Fast Mode High-Speed Mode, $C_B = 100\text{pF}$ max <sup>(2)</sup> High-Speed Mode, $C_B = 400\text{pF}$ max <sup>(2)</sup>	$20 + 0.1C_B$ $20 + 0.1C_B$ 10 20	1000 300 40 80	ns ns ns ns
Rise Time of SCL Signal After a Repeated START Condition and After an Acknowledge Bit	$t_{\text{RCL1}}$	Standard Mode Fast Mode High-Speed Mode, $C_B = 100\text{pF}$ max <sup>(2)</sup> High-Speed Mode, $C_B = 400\text{pF}$ max <sup>(2)</sup>	$20 + 0.1C_B$ $20 + 0.1C_B$ 10 20	1000 300 80 160	ns ns ns ns
Fall Time of SCL Signal	$t_{\text{FCL}}$	Standard Mode Fast Mode High-Speed Mode, $C_B = 100\text{pF}$ max <sup>(2)</sup> High-Speed Mode, $C_B = 400\text{pF}$ max <sup>(2)</sup>	$20 + 0.1C_B$ $20 + 0.1C_B$ 10 20	300 300 40 80	ns ns ns ns
Rise Time of SDA Signal	$t_{\text{RDA}}$	Standard Mode Fast Mode High-Speed Mode, $C_B = 100\text{pF}$ max <sup>(2)</sup> High-Speed Mode, $C_B = 400\text{pF}$ max <sup>(2)</sup>	$20 + 0.1C_B$ $20 + 0.1C_B$ 10 20	1000 300 80 160	ns ns ns ns
Fall Time of SDA Signal	$t_{\text{FDA}}$	Standard Mode Fast Mode High-Speed Mode, $C_B = 100\text{pF}$ max <sup>(2)</sup> High-Speed Mode, $C_B = 400\text{pF}$ max <sup>(2)</sup>	$20 + 0.1C_B$ $20 + 0.1C_B$ 10 20	300 300 80 160	ns ns ns ns
Setup Time for STOP Condition	$t_{\text{SU:STO}}$	Standard Mode Fast Mode High-Speed Mode	4.0 600 160		$\mu\text{s}$ ns ns
Capacitive Load for SDA and SCL Line	$C_B$			400	pF
Pulse Width of Spike Suppressed	$t_{\text{SP}}$	Fast Mode High-Speed Mode		50 10	ns ns
Noise Margin at the HIGH Level for Each Connected Device (Including Hysteresis)	$V_{\text{NH}}$	Standard Mode Fast Mode High-Speed Mode	0.2 $V_{\text{DD}}$		V
Noise Margin at the LOW Level for Each Connected Device (Including Hysteresis)	$V_{\text{NL}}$	Standard Mode Fast Mode High-Speed Mode	0.1 $V_{\text{DD}}$		V

NOTES: (1) All values referred to  $V_{\text{IHMIN}}$  and  $V_{\text{ILMAX}}$  levels. (2) For bus line loads  $C_B$  between 100pF and 400pF the timing parameters must be linearly interpolated. (3) A device must internally provide a data hold time to bridge the undefined part between  $V_{\text{IH}}$  and  $V_{\text{IL}}$  of the falling edge of the SCLH signal. An input circuit with a threshold as low as possible for the falling edge of the SCLH signal minimizes this hold time.

# TYPICAL CHARACTERISTICS

$T_A = +25^\circ\text{C}$ ,  $V_{DD} = +2.7\text{V}$ ,  $V_{REF} = \text{External } +2.5\text{V}$ ,  $f_{\text{SAMPLE}} = 50\text{kHz}$ , unless otherwise noted.

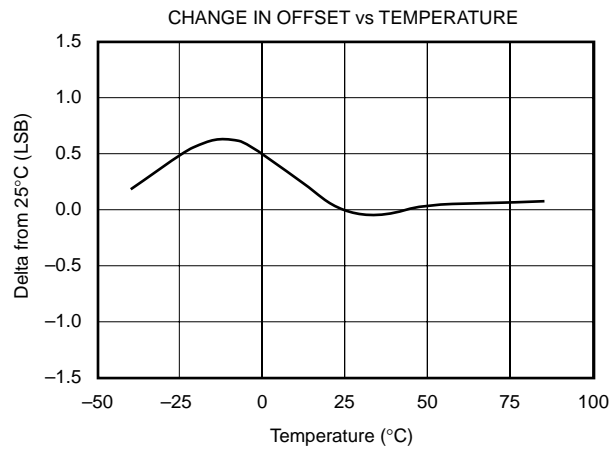
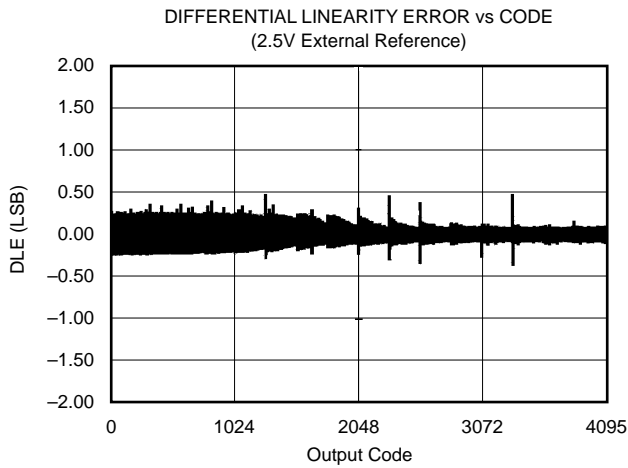
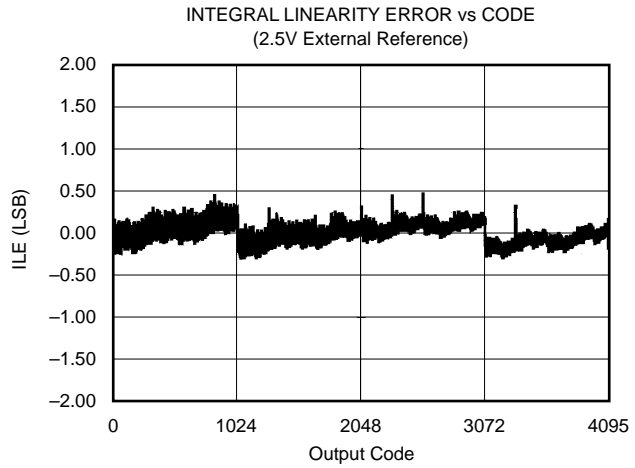
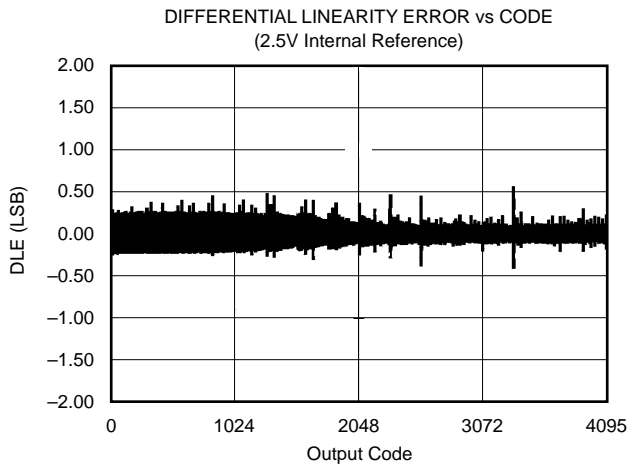
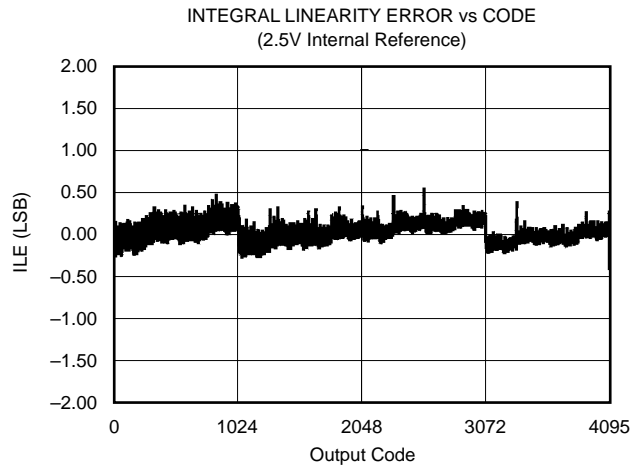
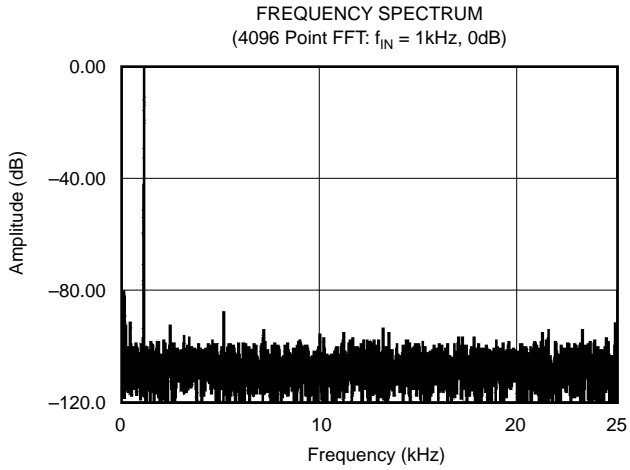

# TYPICAL CHARACTERISTICS (Cont.)

$T_A = +25^\circ\text{C}$ ,  $V_{DD} = +2.7\text{V}$ ,  $V_{REF} = \text{External } +2.5\text{V}$ ,  $f_{\text{SAMPLE}} = 50\text{kHz}$ , unless otherwise noted.

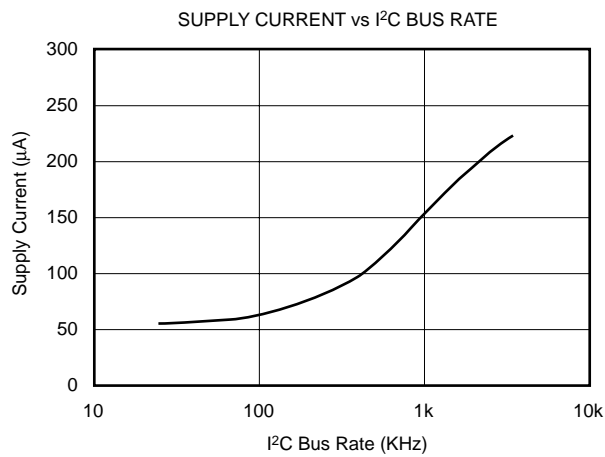
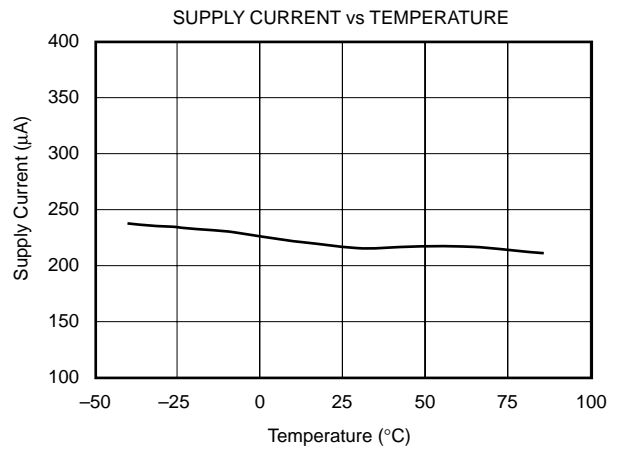
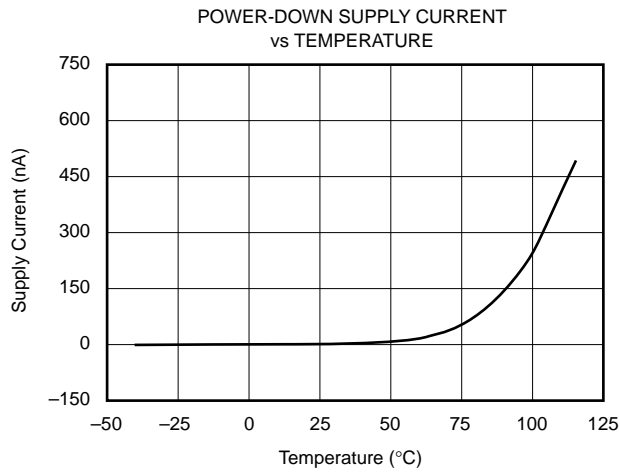
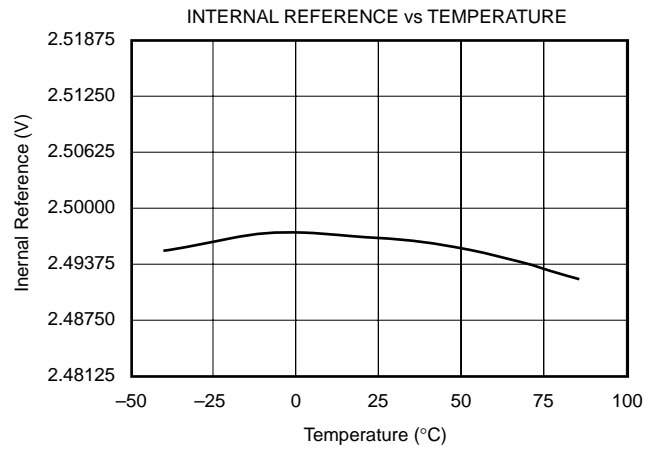
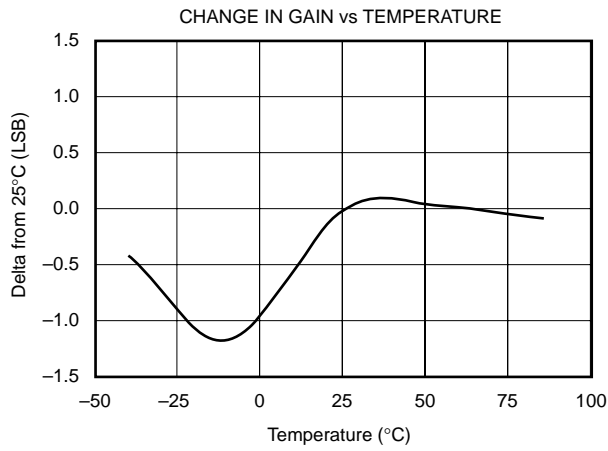

# THEORY OF OPERATION

The ADS7828 is a classic Successive Approximation Register (SAR) A/D converter. The architecture is based on capacitive redistribution which inherently includes a sample-and-hold function. The converter is fabricated on a 0.6 $\mu$ m CMOS process.

The ADS7828 core is controlled by an internally generated free-running clock. When the ADS7828 is not performing conversions or being addressed, it keeps the A/D converter core powered off, and the internal clock does not operate.

The basic operation of the ADS7828 is shown in Figure 1.

## ANALOG INPUT

When the converter enters the hold mode, the voltage on the selected CHx pin is captured on the internal capacitor array. The input current on the analog inputs depends on the conversion rate of the device. During the sample period, the source must charge the internal sampling capacitor (typically 25pF). After the capacitor has been fully charged, there is no further input current. The amount of charge transfer from the analog source to the converter is a function of conversion rate.

## REFERENCE

The ADS7828 can operate with its internal 2.5V reference or an external reference. When using a +2.7V supply, the internal 2.5V reference will provide full dynamic range for a 0V to +V<sub>DD</sub> analog input. If a +5V supply is used, an external 5V reference is required in order to provide full dynamic

range for a 0V to +V<sub>DD</sub> analog input. This external reference can be as low as 50mV.

As the reference voltage is reduced, the analog voltage weight of each digital output code is reduced. This is often referred to as the LSB (least significant bit) size and is equal to the reference voltage divided by 4096. This means that any offset or gain error inherent in the A/D converter will appear to increase, in terms of LSB size, as the reference voltage is reduced.

The noise inherent in the converter will also appear to increase with lower LSB size. With a 2.5V reference, the internal noise of the converter typically contributes only 0.32LSB peak-to-peak of potential error to the output code. When the external reference is 50mV, the potential error contribution from the internal noise will be 50 times larger—16LSBs. The errors due to the internal noise are gaussian in nature and can be reduced by averaging consecutive conversion results.

## DIGITAL INTERFACE

The ADS7828 supports the I<sup>2</sup>C serial bus and data transmission protocol, in all three defined modes: standard, fast, and high-speed. A device that sends data onto the bus is defined as a transmitter, and a device receiving data as a receiver. The device that controls the message is called a “master”. The devices that are controlled by the master are “slaves”. The bus must be controlled by a master device that generates the serial clock (SCL), controls the bus access, and generates the START and STOP conditions. The ADS7828 operates as a slave on the I<sup>2</sup>C bus. Connections to the bus are made via the open-drain I/O lines SDA and SCL.

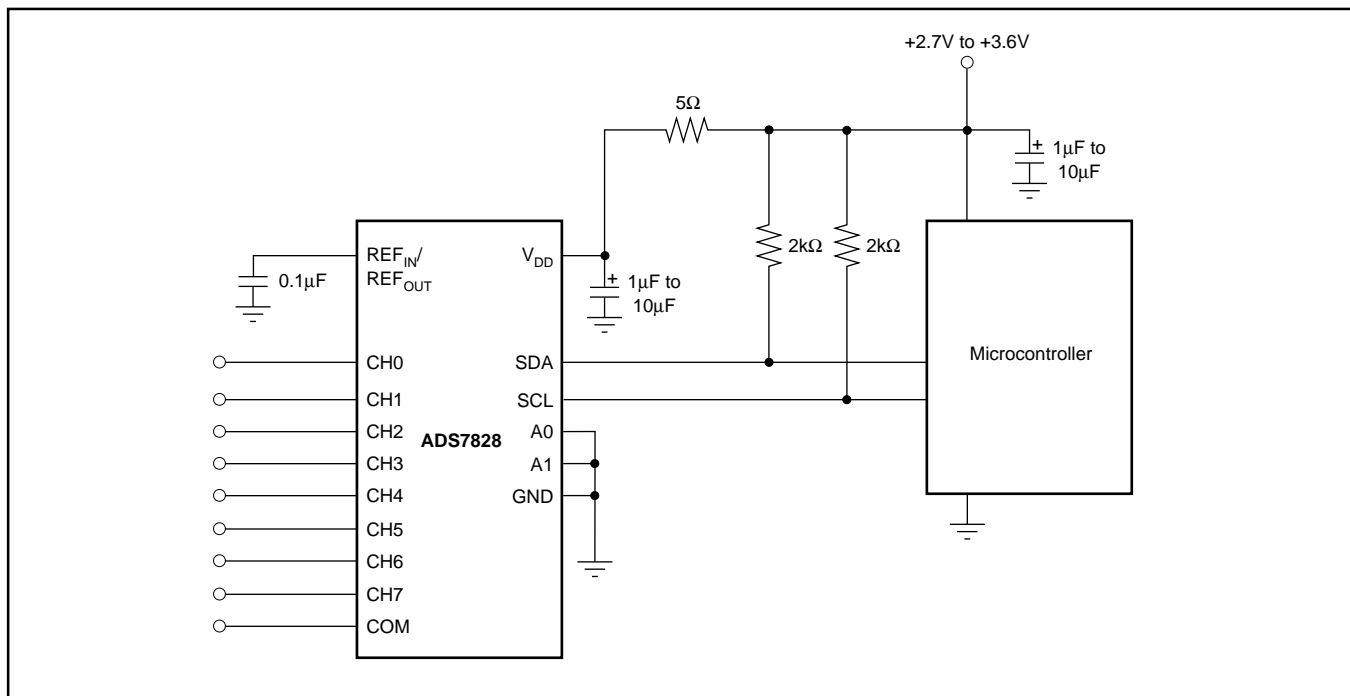

FIGURE 1. Basic Operation of the ADS7828.

The following bus protocol has been defined (as shown in Figure 2):

- Data transfer may be initiated only when the bus is not busy.
- During data transfer, the data line must remain stable whenever the clock line is HIGH. Changes in the data line while the clock line is HIGH will be interpreted as control signals.

Accordingly, the following bus conditions have been defined:

**Bus Not Busy:** Both data and clock lines remain HIGH.

**Start Data Transfer:** A change in the state of the data line, from HIGH to LOW, while the clock is HIGH, defines a START condition.

**Stop Data Transfer:** A change in the state of the data line, from LOW to HIGH, while the clock line is HIGH, defines the STOP condition.

**Data Valid:** The state of the data line represents valid data, when, after a START condition, the data line is stable for the duration of the HIGH period of the clock signal. There is one clock pulse per bit of data.

Each data transfer is initiated with a START condition and terminated with a STOP condition. The number of data bytes transferred between START and STOP conditions is not limited and is determined by the master device. The information is transferred byte-wise and each receiver acknowledges with a ninth-bit.

Within the I<sup>2</sup>C bus specifications a standard mode (100kHz clock rate), a fast mode (400kHz clock rate), and a high-speed mode (3.4MHz clock rate) are defined. The ADS7828 works in all three modes.

**Acknowledge:** Each receiving device, when addressed, is obliged to generate an acknowledge after the reception of each byte. The master device must generate an extra clock pulse that is associated with this acknowledge bit.

A device that acknowledges must pull down the SDA line during the acknowledge clock pulse in such a way that the SDA line is stable LOW during the HIGH period of the acknowledge clock pulse. Of course, setup and hold times

must be taken into account. A master must signal an end of data to the slave by not generating an acknowledge bit on the last byte that has been clocked out of the slave. In this case, the slave must leave the data line HIGH to enable the master to generate the STOP condition.

Figure 2 details how data transfer is accomplished on the I<sup>2</sup>C bus. Depending upon the state of the R/W bit, two types of data transfer are possible:

- 1. Data transfer from a master transmitter to a slave receiver.** The first byte transmitted by the master is the slave address. Next follows a number of data bytes. The slave returns an acknowledge bit after the slave address and each received byte.
- 2. Data transfer from a slave transmitter to a master receiver.** The first byte, the slave address, is transmitted by the master. The slave then returns an acknowledge bit. Next, a number of data bytes are transmitted by the slave to the master. The master returns an acknowledge bit after all received bytes other than the last byte. At the end of the last received byte, a 'not acknowledge' is returned.

The master device generates all of the serial clock pulses and the START and STOP conditions. A transfer is ended with a STOP condition or a repeated START condition. Since a repeated START condition is also the beginning of the next serial transfer, the bus will not be released.

The ADS7828 may operate in the following two modes:

- **Slave Receiver Mode:** Serial data and clock are received through SDA and SCL. After each byte is received, an acknowledge bit is transmitted. START and STOP conditions are recognized as the beginning and end of a serial transfer. Address recognition is performed by hardware after reception of the slave address and direction bit.
- **Slave Transmitter Mode:** The first byte (the slave address) is received and handled as in the slave receiver mode. However, in this mode the direction bit will indicate that the transfer direction is reversed. Serial data is transmitted on SDA by the ADS7828 while the serial clock is input on SCL. START and STOP conditions are recognized as the beginning and end of a serial transfer.

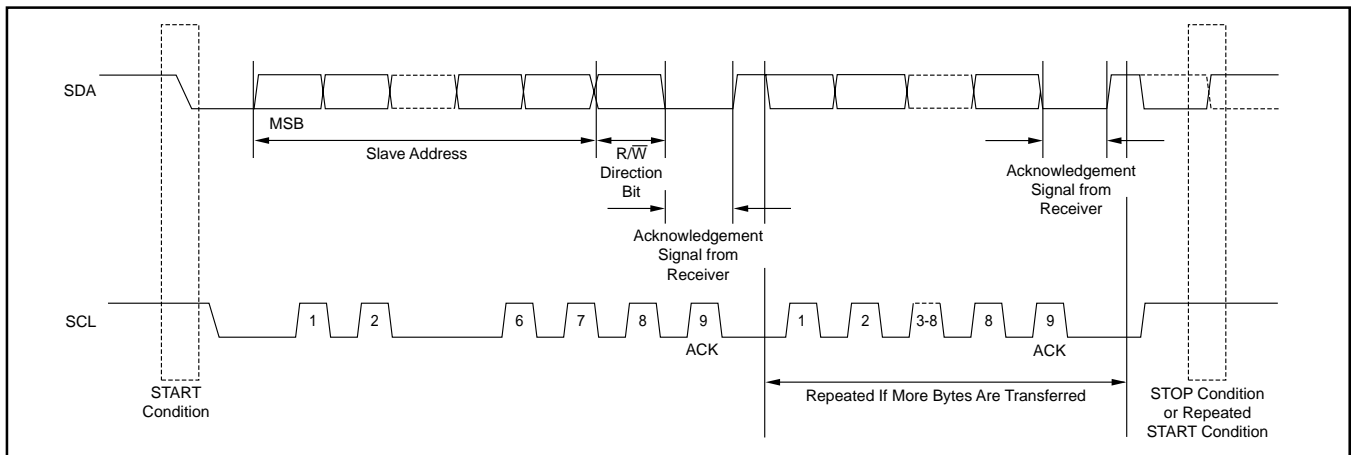

FIGURE 2. Simplified Diagram of the Analog Input.

## Address Byte

MSB	6	5	4	3	2	1	LSB
1	0	0	1	0	A1	A0	R $\overline{W}$

The address byte is the first byte received following the START condition from the master device. The first five bits (MSBs) of the slave address are factory pre-set to 10010. The next two bits of the address byte are the device select bits, A1 and A0. Input pins (A1-A0) on the ADS7828 determine these two bits of the device address for a particular ADS7828. A maximum of four devices with the same pre-set code can therefore be connected on the same bus at one time.

The A1-A0 Address Inputs can be connected to  $V_{DD}$  or digital ground, or can be actively driven by TTL or CMOS logic levels. The device address is set by the state of these pins upon power-up of the ADS7828.

The last bit of the address byte (R $\overline{W}$ ) defines the operation to be performed. When set to a "1" a read operation is selected; when set to a "0" a write operation is selected. Following the START condition the ADS7828 monitors the SDA bus, checking the device type identifier being transmitted. Upon receiving the 10010 code, the appropriate device select bits, and the R $\overline{W}$  bit, the slave device outputs an acknowledge signal on the SDA line.

## Command Byte

MSB	6	5	4	3	2	1	LSB
SD	C2	C1	C0	PD1	PD0	X	X

The ADS7828's operating mode is determined by a command byte which is illustrated above.

SD: Single-Ended/Differential Inputs

0: Differential Inputs

1: Single-Ended Inputs

C2 - C0: Channel Selections

PD1 - 0: Power-Down Selection

X: Unused

See Table I for Truth Table.

## POWER-DOWN SELECTION

PD1	PD0	DESCRIPTION
0	0	Power Down Between A/D Converter Conversions
0	1	Internal Reference OFF and A/D Converter ON
1	0	Internal Reference ON and A/D Converter OFF
1	1	Internal Reference ON and A/D Converter ON

## INITIATING CONVERSION

Provided the master has write-addressed it, the ADS7828 turns on the A/D converter's section and begins conversions when it receives BIT 4 of the command byte shown in the Command Byte. If the command byte is correct, the ADS7828 will return an ACK condition.

CHANNEL SELECTION CONTROL												
SD	C2	C1	C0	CH0	CH1	CH2	CH3	CH4	CH5	CH6	CH7	COM
0	0	0	0	+IN	-IN	—	—	—	—	—	—	—
0	0	0	1	—	—	+IN	-IN	—	—	—	—	—
0	0	1	0	—	—	—	—	+IN	-IN	—	—	—
0	0	1	1	—	—	—	—	—	—	+IN	-IN	—
0	1	0	0	-IN	+IN	—	—	—	—	—	—	—
0	1	0	1	—	—	-IN	+IN	—	—	—	—	—
0	1	1	0	—	—	—	—	-IN	+IN	—	—	—
0	1	1	1	—	—	—	—	—	—	-IN	+IN	—
1	0	0	0	+IN	—	—	—	—	—	—	—	-IN
1	0	0	1	—	—	+IN	—	—	—	—	—	-IN
1	0	1	0	—	—	—	—	+IN	—	—	—	-IN
1	0	1	1	—	—	—	—	—	—	+IN	—	-IN
1	1	0	0	—	+IN	—	—	—	—	—	—	-IN
1	1	0	1	—	—	—	+IN	—	—	—	—	-IN
1	1	1	0	—	—	—	—	—	+IN	—	—	-IN
1	1	1	1	—	—	—	—	—	—	—	+IN	-IN

TABLE I. Channel Selection Control Addressed by Command BYTE.

## READING DATA

Data can be read from the ADS7828 by read-addressing the part (LSB of address byte set to 1) and receiving the transmitted bytes. Converted data can only be read from the ADS7828 once a conversion has been initiated as described in the preceding section.

Each 12-bit data word is returned in two bytes, as shown below, where D11 is the MSB of the data word, and D0 is the LSB. Byte 0 is sent first, followed by Byte 1.

	MSB	6	5	4	3	2	1	LSB
BYTE 0	0	0	0	0	D11	D10	D9	D8
BYTE 1	D7	D6	D5	D4	D3	D2	D1	D0

## READING IN F/S MODE

Figure 3 describes the interaction between the master and the slave ADS7828 during Fast Mode Operation. At the end of reading conversion data the ADS7828 can be issued a repeated START condition by the master to secure bus operation for subsequent conversions of the A/D converter. This would be the most efficient way to perform continuous conversions.

## READING IN HS MODE

High Speed mode is fast enough that codes can be read out one at a time. In High Speed mode, there is not enough time for a single conversion to complete between the reception of a repeated START condition and the read-addressing byte, so the ADS7828 stretches the clock after the read-addressing byte has been fully received, holding it LOW until the conversion is complete.

See Figure 4 for typical read sequence for High Speed mode. Included in the read sequence is the shift from F/S to

HS modes. It may be desirable to remain in HS mode after reading a conversion; to do this, issue a repeated START instead of a STOP at the end of the read sequence, since a STOP causes the part to return to F/S mode.

## LAYOUT

For optimum performance, care should be taken with the physical layout of the ADS7828 circuitry. The basic SAR architecture is sensitive to glitches or sudden changes on the power supply, reference, ground connections, and digital inputs that occur just prior to latching the output of the analog comparator. Therefore, during any single conversion for an “n-bit” SAR converter, there are n “windows” in which large external transient voltages can easily affect the conversion result. Such glitches might originate from switching power supplies, nearby digital logic, and high-power devices.

With this in mind, power to the ADS7828 should be clean and well bypassed. A 0.1µF ceramic bypass capacitor should be placed as close to the device as possible. A 1µF to 10µF capacitor may also be needed if the impedance of the connection between +V<sub>DD</sub> and the power supply is high.

The ADS7828 architecture offers no inherent rejection of noise or voltage variation in regards to using an external reference input. This is of particular concern when the reference input is tied to the power supply. Any noise and ripple from the supply will appear directly in the digital results. While high-frequency noise can be filtered out, voltage variation due to line frequency (50Hz or 60Hz) can be difficult to remove.

The GND pin should be connected to a clean ground point. In many cases, this will be the “analog” ground. Avoid connections that are too near the grounding point of a microcontroller or digital signal processor. The ideal layout will include an analog ground plane dedicated to the converter and associated analog circuitry.

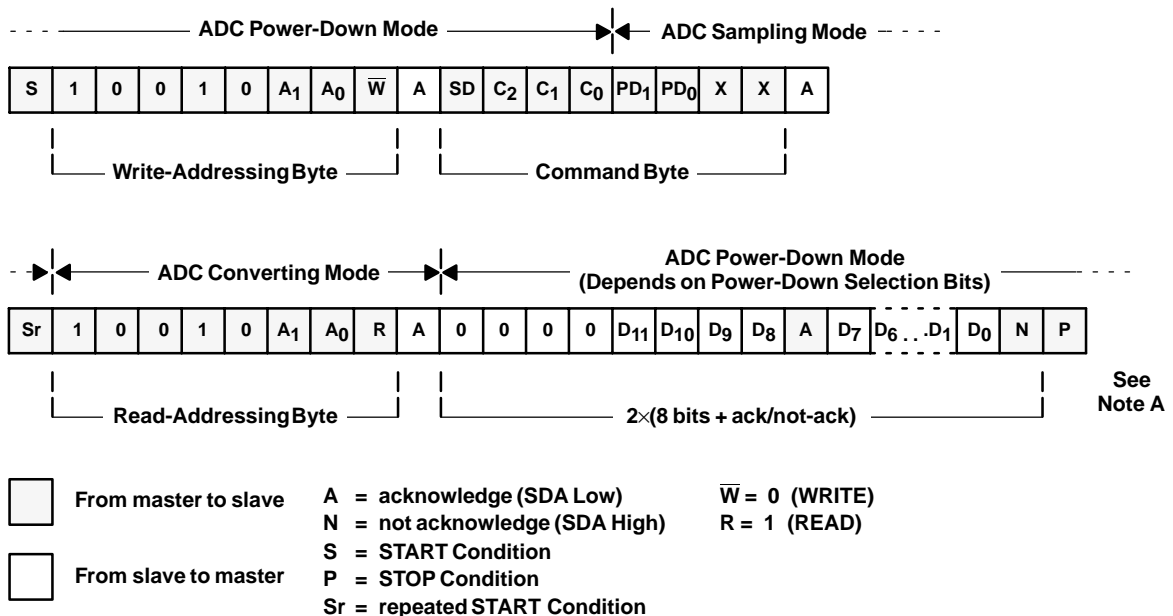

NOTE: (A) Use repeated START to secure bus operation and loop back to the stage of write-addressing for next conversion.

FIGURE 3. Typical Read Sequence in F/S Mode.

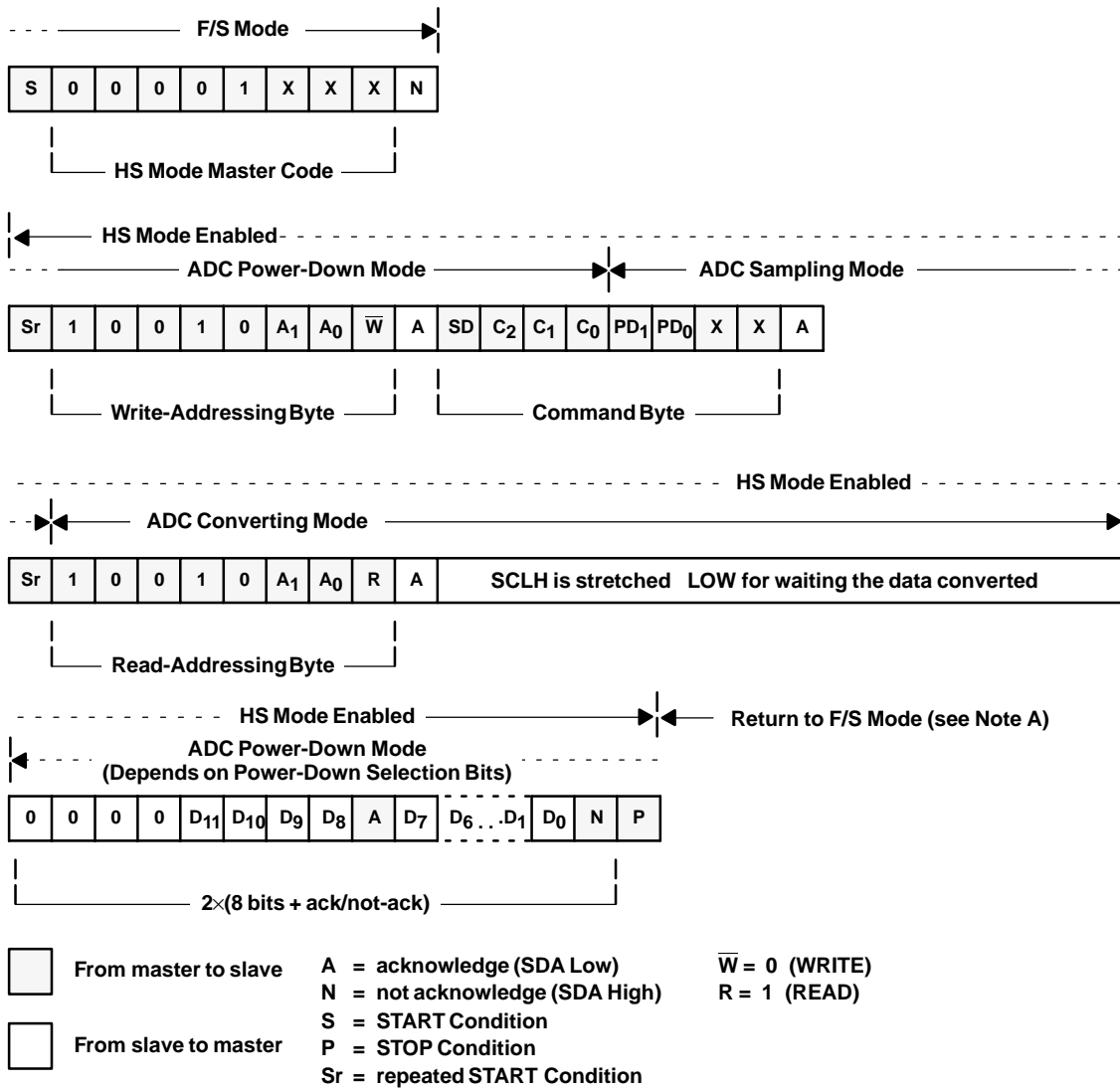

NOTE: (A) Use repeated START to remain in HS mode instead of STOP.

FIGURE 4. Typical Read Sequence in HS Mode.

PW (R-PDSO-G\*\*)

PLASTIC SMALL-OUTLINE PACKAGE

14 PINS SHOWN

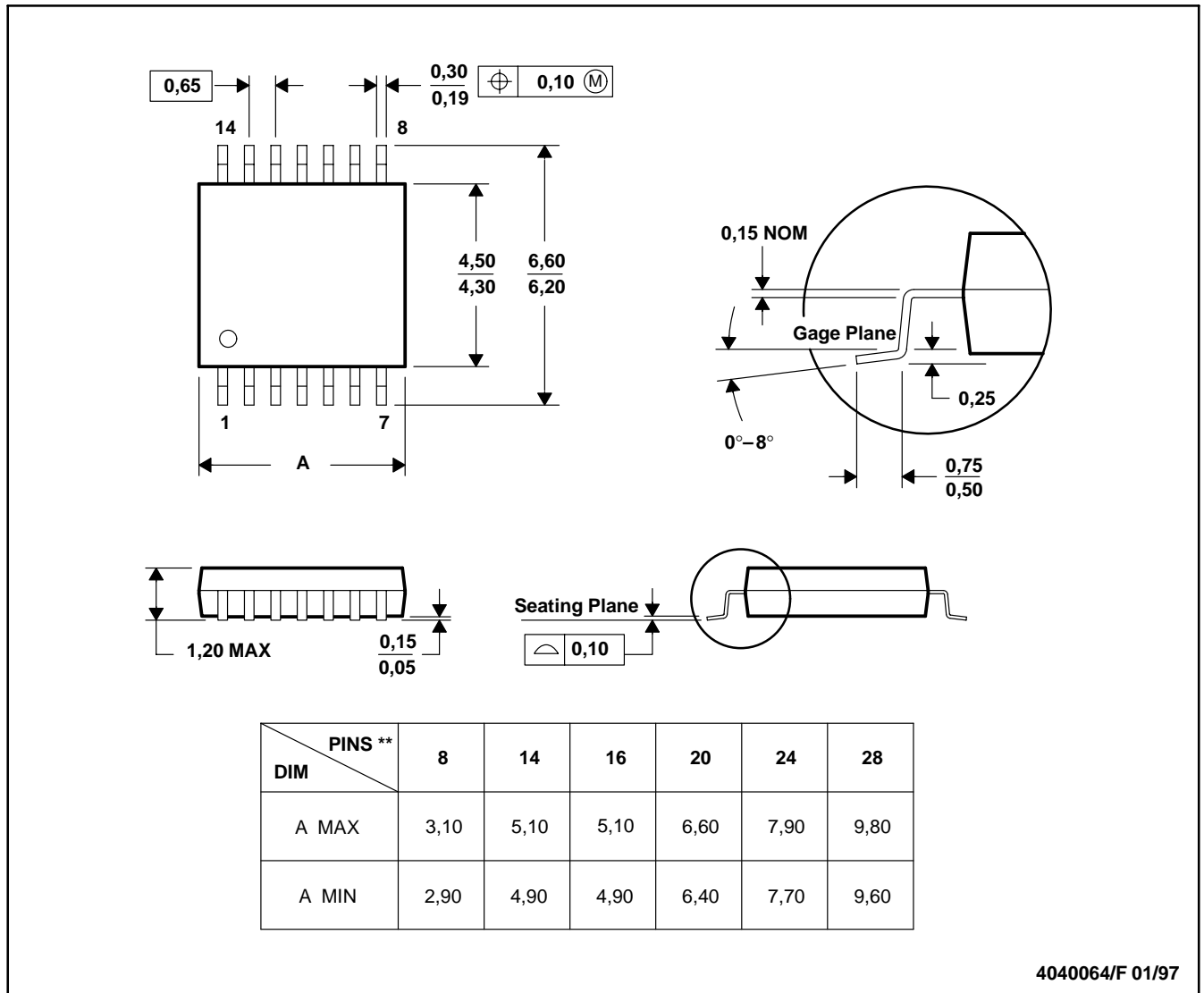

4040064/F 01/97

- NOTES: A. All linear dimensions are in millimeters.  
 B. This drawing is subject to change without notice.  
 C. Body dimensions do not include mold flash or protrusion not to exceed 0,15.  
 D. Falls within JEDEC MO-153

## IMPORTANT NOTICE

Texas Instruments Incorporated and its subsidiaries (TI) reserve the right to make corrections, modifications, enhancements, improvements, and other changes to its products and services at any time and to discontinue any product or service without notice. Customers should obtain the latest relevant information before placing orders and should verify that such information is current and complete. All products are sold subject to TI's terms and conditions of sale supplied at the time of order acknowledgment.

TI warrants performance of its hardware products to the specifications applicable at the time of sale in accordance with TI's standard warranty. Testing and other quality control techniques are used to the extent TI deems necessary to support this warranty. Except where mandated by government requirements, testing of all parameters of each product is not necessarily performed.

TI assumes no liability for applications assistance or customer product design. Customers are responsible for their products and applications using TI components. To minimize the risks associated with customer products and applications, customers should provide adequate design and operating safeguards.

TI does not warrant or represent that any license, either express or implied, is granted under any TI patent right, copyright, mask work right, or other TI intellectual property right relating to any combination, machine, or process in which TI products or services are used. Information published by TI regarding third-party products or services does not constitute a license from TI to use such products or services or a warranty or endorsement thereof. Use of such information may require a license from a third party under the patents or other intellectual property of the third party, or a license from TI under the patents or other intellectual property of TI.

Reproduction of information in TI data books or data sheets is permissible only if reproduction is without alteration and is accompanied by all associated warranties, conditions, limitations, and notices. Reproduction of this information with alteration is an unfair and deceptive business practice. TI is not responsible or liable for such altered documentation.

Resale of TI products or services with statements different from or beyond the parameters stated by TI for that product or service voids all express and any implied warranties for the associated TI product or service and is an unfair and deceptive business practice. TI is not responsible or liable for any such statements.

### Mailing Address:

Texas Instruments  
Post Office Box 655303  
Dallas, Texas 75265

This datasheet has been download from:

[www.datasheetcatalog.com](http://www.datasheetcatalog.com)

Datasheets for electronics components.