

AM26LV32E Low-Voltage High-Speed Quadruple Differential Line Receiver With ± 15 -KV IEC ESD Protection

1 Features

- Meets or Exceeds Standard TIA/EIA-422-B and ITU Recommendation V.11
- Operates From a Single 3.3-V Power Supply
- Switching Rates up to 32 MHz
- ESD Protection for RS422 Bus Pins (See [ESD Ratings](#))
- Low Power Dissipation: 27 mW Typ
- Open Circuit, Short Circuit, and Terminated Fail-Safe
- ± 7 -V Common-Mode Input Voltage Range With ± 200 -mV Sensitivity
- Accepts 5-V Logic Inputs With 3.3-V Supply (Enable Inputs)
- Input Hysteresis: 35 mV Typ
- Pin-to-Pin Compatible With AM26C32, AM26LS32
- I_{off} Supports Partial-Power-Down Mode Operation

2 Applications

- High-Reliability Automotive Applications
- Configuration Control/Print Support
- ATM and Cash Counters
- Smart Grid
- AC and Servo Motor Drives

3 Description

The AM26LV32E device consists of quadruple differential line receivers with 3-state outputs. This device is designed to meet TIA/EIA-422-B and ITU recommendation V.11 drivers with reduced supply voltage. The device is optimized for balanced bus transmission at switching rates up to 32 MHz. The 3-state outputs permit connection directly to a bus-organized system. The AM26LV32E has an internal fail-safe circuitry that prevents the device from putting an unknown voltage signal at the receiver outputs. In the open fail-safe, shorted fail-safe, and terminated fail-safe, a high state is produced at the respective output. This device is supported for partial-power-down applications using I_{off} . I_{off} circuitry disables the outputs, preventing damaging current back-flow through the device when it is powered down.

Device Information⁽¹⁾

PART NUMBER	PACKAGE	BODY SIZE (NOM)
AM26LV32E	SO (16)	10.20 mm x 5.30 mm
AM26LV32E	SOIC (16)	9.90 mm x 3.90 mm
AM26LV32E	VQFN (16)	4.00 mm x 3.50 mm
AM26LV32E	TSSOP (16)	5.00 mm x 4.40 mm

(1) For all available packages, see the orderable addendum at the end of the data sheet.

Logic Diagram (Positive Logic)

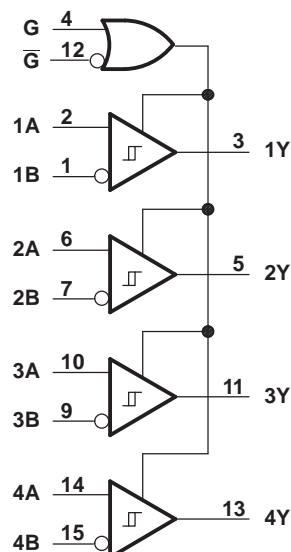

Table of Contents

1 Features 1 2 Applications 1 3 Description 1 4 Revision History 2 5 Pin Configuration and Functions 3 6 Specifications 4 6.1 Absolute Maximum Ratings 4 6.2 ESD Ratings 4 6.3 Recommended Operating Conditions 4 6.4 Thermal Information 4 6.5 Electrical Characteristics 5 6.6 Switching Characteristics 5 6.7 Typical Characteristics 6 7 Parameter Measurement Information 7 8 Detailed Description 8 8.1 Overview 8	8.2 Functional Block Diagram 8 8.3 Feature Description 8 8.4 Device Functional Modes 9 9 Application and Implementation 10 9.1 Application Information 10 9.2 Typical Application 10 10 Power Supply Recommendations 11 11 Layout 11 11.1 Layout Guidelines 11 11.2 Layout Example 12 12 Device and Documentation Support 13 12.1 Community Resources 13 12.2 Trademarks 13 12.3 Electrostatic Discharge Caution 13 12.4 Glossary 13 13 Mechanical, Packaging, and Orderable Information 13
---	---

4 Revision History

NOTE: Page numbers for previous revisions may differ from page numbers in the current version.

Changes from Revision A (May 2008) to Revision B	Page
<ul style="list-style-type: none"> • Added <i>Pin Configuration and Functions</i> section, <i>ESD Ratings</i> table, <i>Feature Description</i> section, <i>Device Functional Modes</i>, <i>Application and Implementation</i> section, <i>Power Supply Recommendations</i> section, <i>Layout</i> section, <i>Device and Documentation Support</i> section, and <i>Mechanical, Packaging, and Orderable Information</i> section 	1

5 Pin Configuration and Functions

**D, NS, or PW Package
16-Pin SOIC, SO, or TSSOP
Top View**

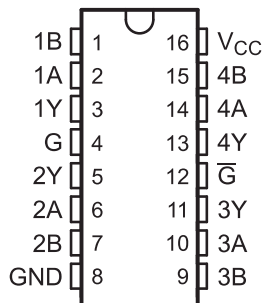

**RGY Package
16-Pin VQFN
Top View**

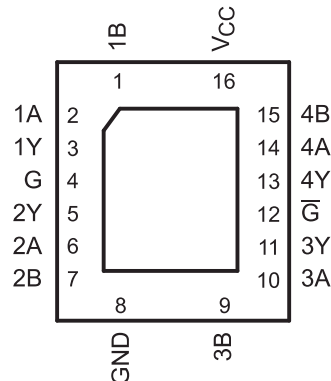

Pin Functions

PIN		I/O	DESCRIPTION
NAME	NO,		
1A	2	I	RS422/RS485 differential input (noninverting)
1B	1	I	RS422/RS485 differential input (inverting)
1Y	3	O	Logic level output
2A	6	I	RS422/RS485 differential input (noninverting)
2B	7	I	RS422/RS485 differential input (inverting)
2Y	5	O	Logic level output
3A	10	I	RS422/RS485 differential input (noninverting)
3B	9	I	RS422/RS485 differential input (inverting)
3Y	11	O	Logic level output
4A	14	I	RS422/RS485 differential input (noninverting)
4B	15	I	RS422/RS485 differential input (inverting)
4Y	13	O	Logic level output
G	4	I	Active-high select
\overline{G}	12	I	Active-low select
GND	8	—	Ground
V _{CC}	16	—	Power Supply

6 Specifications

6.1 Absolute Maximum Ratings

 over operating free-air temperature range (unless otherwise noted) ⁽¹⁾⁽²⁾

		MIN	MAX	UNIT	
V _{CC}	Supply voltage ⁽³⁾	-0.5	6	V	
V _I	Input voltage	A or B inputs	-14	14	V
		G or \bar{G} inputs	-0.5	6	
V _{ID}	Differential input voltage ⁽⁴⁾	-14	14	V	
V _O	Output voltage	-0.5	6	V	
I _O	Output current		±20	mA	
I _{IK}	Input clamp current	V _I < 0	-20	mA	
I _{OK}	Output clamp current	V _O < 0	-20	mA	
T _J	Operating virtual junction temperature		150	°C	
T _{stg}	Storage temperature	-65	150	°C	

- (1) Stresses beyond those listed under *Absolute Maximum Ratings* may cause permanent damage to the device. These are stress ratings only, which do not imply functional operation of the device at these or any other conditions beyond those indicated under *Recommended Operating Conditions*. Exposure to absolute-maximum-rated conditions for extended periods may affect device reliability.
- (2) This device is designed to meet TIA/EIA-422-B and ITU.
- (3) All voltage values except differential input voltage are with respect to the network GND.
- (4) Differential input voltage is measured at the non-inverting input with respect to the corresponding inverting input.

6.2 ESD Ratings

		VALUE	UNIT	
V _(ESD)	Electrostatic discharge	Human body model (HBM), per ANSI/ESDA/JEDEC JS-001 ⁽¹⁾	±15000	V
		IEC61000-4-2, Contact Gap Discharge	±8000	
		IEC61000-4-2, Air Gap Discharge	±15000	

- (1) JEDEC document JEP155 states that 500-V HBM allows safe manufacturing with a standard ESD control process. Manufacturing with less than 500-V HBM is possible with the necessary precautions. Pins listed as ±15000 V may actually have higher performance.

6.3 Recommended Operating Conditions

over operating free-air temperature range (unless otherwise noted)

		MIN	NOM	MAX	UNIT
V _{CC}	Supply voltage	3	3.3	3.6	V
V _{IH}	High-level input voltage	2		5.5	V
V _{IL}	Low-level input voltage	0		0.8	V
V _{IC}	Common-mode input voltage	-7		7	V
V _{ID}	Differential input voltage	-7		7	V
I _{OH}	High-level output current			-5	mA
I _{OL}	Low-level output current			5	mA
T _A	Operating free-air temperature	-40		85	°C

6.4 Thermal Information

THERMAL METRIC ⁽¹⁾	AM26LV32E				UNIT	
	D (SOIC)	PW (TSSOP)	NS (SOP)	RGY (VQFN)		
	16 PINS	16 PINS	16 PINS	16 PINS		
R _{θJA}	Junction-to-ambient thermal resistance	73.1	109	69	92	°C/W
R _{θJC(top)}	Junction-to-case (top) thermal resistance	38.4	34	34	40	°C/W

- (1) For more information about traditional and new thermal metrics, see the *Semiconductor and IC Package Thermal Metrics* application report, [SPRA953](#).

6.5 Electrical Characteristics

over recommended ranges of common-mode input, supply voltage, and operating free-air temperature (unless otherwise noted)

PARAMETER		TEST CONDITIONS	MIN	TYP	MAX	UNIT
V_{IT+}	Positive-going input threshold voltage, differential input				0.2	V
V_{IT-}	Negative-going input threshold voltage, differential input		-0.2			V
V_{hys}	Input hysteresis ($V_{IT+} - V_{IT-}$)			35		mV
V_{IK}	Input clamp voltage, G and \bar{G}	$I_I = -18$ mA			-1.5	V
V_{OH}	High-level output voltage	$V_{ID} = 200$ mV, $I_{OH} = -5$ mA	2.4	3.2		V
		$V_{ID} = 200$ mV, $I_{OH} = -100$ μ A	$V_{CC} - 0.1$			
V_{OL}	Low-level output voltage	$V_{ID} = -200$ mV, $I_{OL} = 5$ mA		0.17	0.5	V
		$V_{ID} = -200$ mV, $I_{OL} = 100$ μ A			0.1	
I_{OZ}	High-impedance state output current	$V_O = V_{CC}$ or GND			± 50	μ A
I_{off}	Output current with power off	$V_{CC} = 0$ V, $V_O = 0$ or 5.5 V			± 100	μ A
I_I	Line input current	Other input at 0 V	$V_I = 10$ V		1.5	mA
			$V_I = -10$ V		-2.5	
I_I	Enable input current, G and \bar{G}	$V_I = V_{CC}$ or GND			± 1	μ A
r_i	Input resistance	$V_{IC} = -7$ V to 7 V, Other input at 0 V	4	17		k Ω
I_{CC}	Supply current (total package)	G, $\bar{G} = V_{CC}$ or GND, No load, Line inputs open		8	17	mA
C_{pd}	Power dissipation capacitance	One channel		150		pF

6.6 Switching Characteristics

over recommended operating free-air temperature range (unless otherwise noted)

PARAMETER		TEST CONDITIONS	MIN	TYP ⁽¹⁾	MAX	UNIT
t_{PLH}	Propagation delay time, low- to high-level output	See Figure 2	8	16	26	ns
t_{PHL}	Propagation delay time, high- to low-level output		8	16	26	ns
t_t	Transition time	See Figure 2		5		ns
t_{PZH}	Output-enable time to high-level	See Figure 3		17	40	ns
t_{PZL}	Output-enable time to low-level	See Figure 3		10	40	ns
t_{PHZ}	Output-disable time from high-level	See Figure 3		20	40	ns
t_{PLZ}	Output-disable time from low-level	See Figure 3		16	40	ns
$t_{sk(p)}$	Pulse skew	See Figure 2 Figure 3		4	6	ns
$t_{sk(o)}$	Pulse skew	See Figure 2 Figure 3		4	6	ns
$t_{sk(pp)}$	Pulse skew (device to device)	See Figure 2 Figure 3		6	9	ns
$f_{(max)}$	Maximum operating frequency	See Figure 2		32		MHz

(1) All typical values are at $V_{CC} = 3.3$ V, $T_A = 25^\circ\text{C}$.

6.7 Typical Characteristics

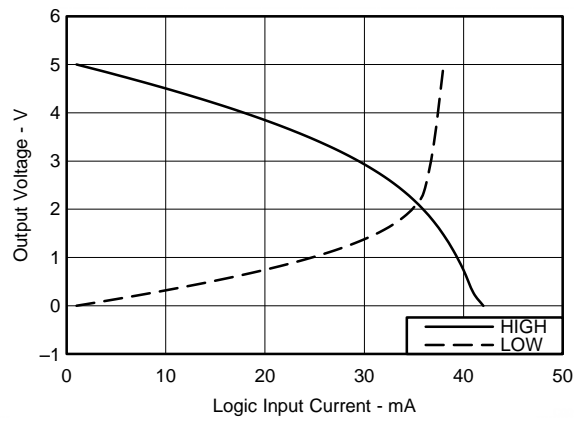
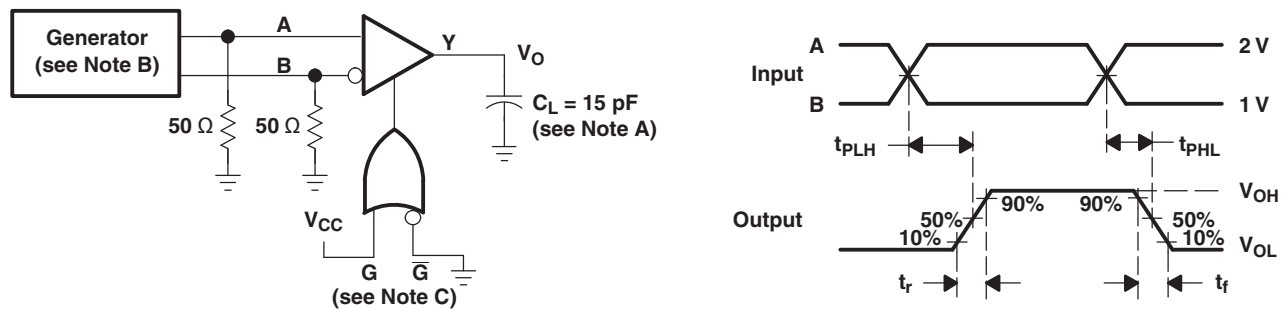

Figure 1. Output Voltage vs Input Current

7 Parameter Measurement Information



A. C_L includes probe and jig capacitance.

Figure 2. Switching Test Circuit and Voltage Waveforms

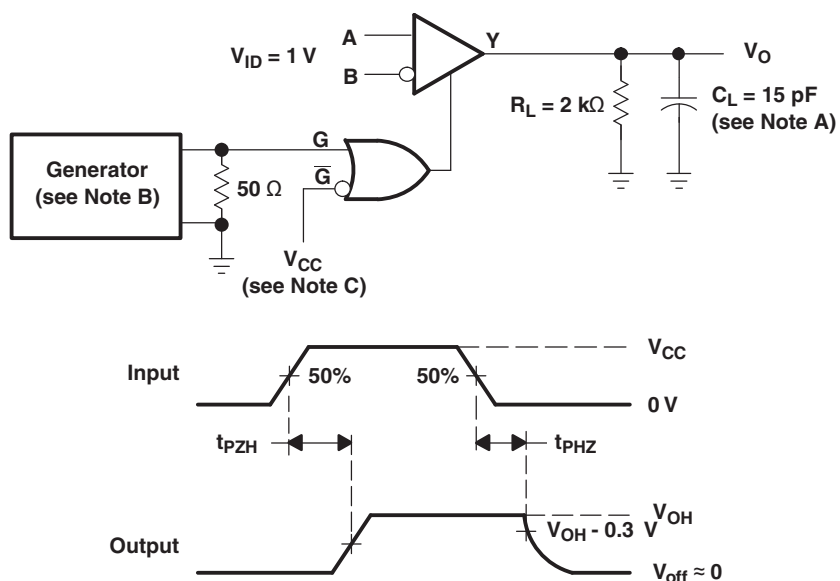

A. C_L includes probe and jig capacitance.

B. The input pulse is supplied by a generator having the following characteristics: PRR = 1 MHz, duty cycle \leq 50%, $t_r = t_f = 6$ ns.

Figure 3. Enable/Disable Time Test Circuit and Output Voltage Waveforms

8 Detailed Description

8.1 Overview

The AM26LV32E is a low-voltage, quadruple-differential line receiver that meets the necessary requirements for NSI TIA/EIA-422-B, TIA/EIA-423-B, and ITU Recommendation V.10 and V.11. This device allows a low power or low voltage MCU to interface with heavy machinery, subsystems and other devices through long wires of up to 1000 m, giving any design a reliable and easy to use connection. As with any RS422 interface, the AM26LV32E works in a differential voltage range, which enables very good signal integrity.

8.2 Functional Block Diagram

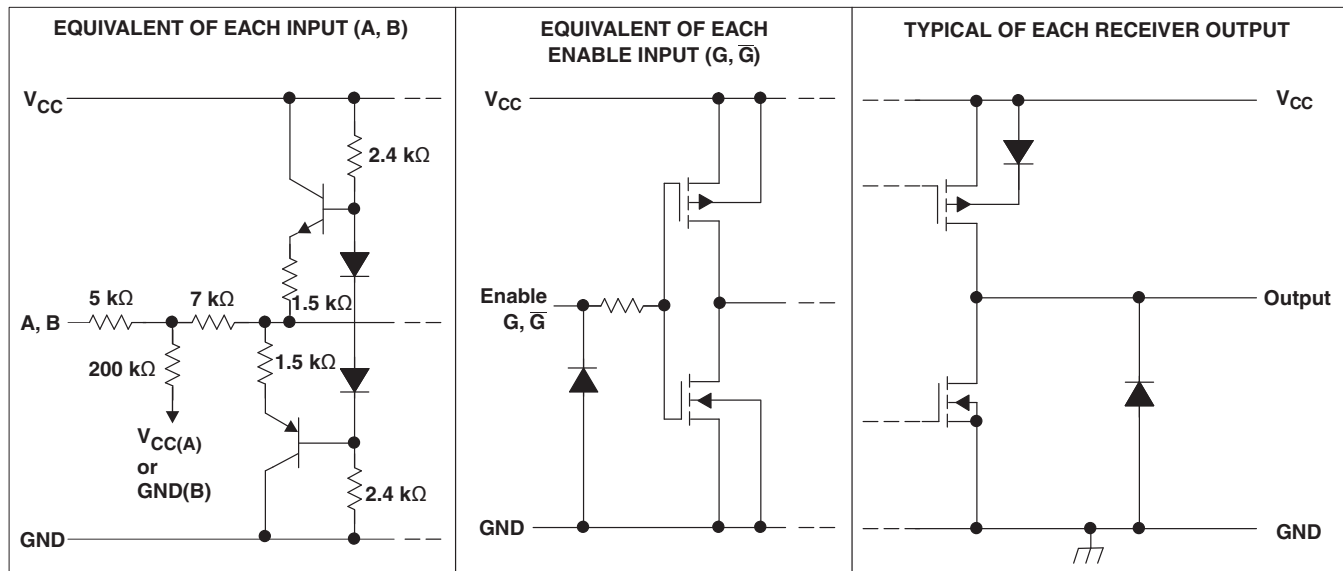

8.3 Feature Description

8.3.1 ± 7 -V Common-Mode Range With ± 200 -mV Sensitivity

For a common-mode voltage varying from -7 V to 7 V, the input voltage is acceptable in low ranges greater than 200 mV as a standard.

8.3.2 Input Fail-Safe Circuitry

RS-485 specifies that the receiver output state should be logic high for differential input voltages of $V_{AB} \geq +200$ mV and logic low for $V_{AB} \leq -200$ mV. For input voltages in between these limits, a receiver's output state is not defined and can randomly assume high or low. Removing the uncertainty of random output states, modern transceiver designs include internal biasing circuits that put the receiver output into a defined state (typically high) in the absence of a valid input signal. A loss of input signal can be caused by:

- an open circuit caused by a wire break or the unintentional disconnection of a transceiver from the bus
- a short circuit due to an insulation fault, connecting both conductors of a differential pair to one another
- an idle bus when none of the bus transceivers are active.

An open circuit caused by a wire break or the unintentional disconnection of a transceiver from the bus. The AM26LV32E has an internal circuit that ensures functionality during an open, terminated or short failure.

8.3.3 Active-High and Active-Low

The device can be configured using the G and \bar{G} logic inputs to select receiver output. The high voltage or logic 1 on the G pin, allows the device to operate on an active-high and having a low voltage or logic 0 on the \bar{G} enables active low operation. These are simply a way to configure the logic to match that of the receiving or transmitting controller or microprocessor.

8.4 Device Functional Modes

8.4.1 Enable and Disable

The receivers implemented in these RS422 devices can be configured using the G and \bar{G} pins to be enabled or disabled. This allows users to ignore or filter out transmissions as desired.

Table 1. Function Table (Each Driver)

DIFFERENTIAL INPUT	ENABLES		OUTPUT
	G	\bar{G}	
$V_{ID} \geq 0.2\text{ V}$	H	X	H
	X	L	H
$-0.2\text{ V} < V_{ID} < 0.2\text{ V}$	H	X	?
	X	L	?
$V_{ID} \leq -0.2\text{ V}$	H	X	L
	X	L	L
Open, shorted, or terminated	H	X	H
	X	L	H
X	L	H	Z

9 Application and Implementation

NOTE

Information in the following applications sections is not part of the TI component specification, and TI does not warrant its accuracy or completeness. TI's customers are responsible for determining suitability of components for their purposes. Customers should validate and test their design implementation to confirm system functionality.

9.1 Application Information

When designing a system that uses drivers, receivers, and transceivers that comply with RS-422 or RS-485, proper cable termination is essential for highly reliable applications with reduced reflections in the transmission line. Because RS-422 allows only one driver on the bus, if termination is used, it is placed only at the end of the cable near the last receiver. In general, RS-485 requires termination at both ends of the cable. Factors to consider when determining the type of termination usually are performance requirements of the application and the ever-present factor, cost. The different types of termination techniques discussed are unterminated lines, parallel termination, ac termination, and multipoint termination. Laboratory waveforms for each termination technique (except multipoint termination) illustrate the usefulness and robustness of RS-422 (and, indirectly, RS-485). Similar results can be obtained if 485-compliant devices and termination techniques are used. For laboratory experiments, 100 feet of 100- Ω , 24-AWG, twisted-pair cable (Bertek) was used. A single driver and receiver, TI AM26LV31E and AM26LV32E, respectively, were tested at room temperature with a 3.3-V supply voltage. Two plots per termination technique are shown. In each plot, the top waveform is the driver input and the bottom waveform is the receiver output. To show voltage waveforms related to transmission-line reflections, the first plot shows output waveforms from the driver at the start of the cable; the second plot shows input waveforms to the receiver at the far end of the cable.

9.2 Typical Application

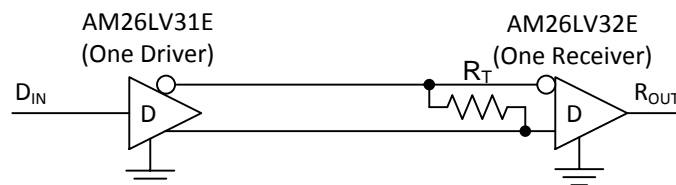

Figure 4. Differential Terminated Configuration

9.2.1 Design Requirements

Resistor and capacitor (if used) termination values are shown for each laboratory experiment, but vary from system to system. For example, the termination resistor, R_T , must be within 20% of the characteristic impedance, R_{OUT} , of the cable and can vary from about 80 Ω to 120 Ω .

9.2.2 Detailed Design Procedure

Figure 4 shows a configuration with R_T as termination. Although reflections are present at the receiver inputs at a data signaling rate of 200 kbps with no termination, the RS-422-compliant receiver reads only the input differential voltage and produces a clean signal at the output.

Typical Application (continued)

9.2.3 Application Curve

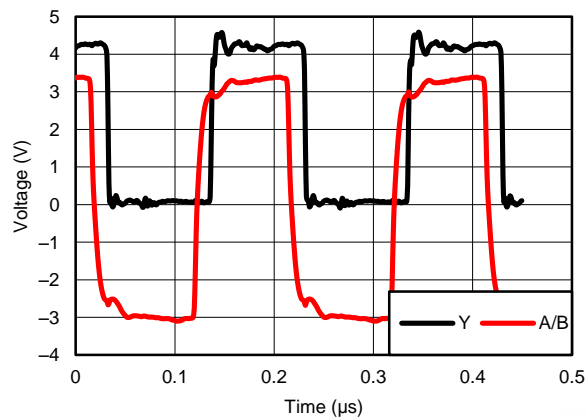

Figure 5. Differential 120-Ω Terminated Output Waveforms (CAT 5E Cable)

10 Power Supply Recommendations

Place 0.1- μ F bypass capacitors close to the power-supply pins to reduce errors coupling in from noisy or high-impedance power supplies.

11 Layout

11.1 Layout Guidelines

For best operational performance of the device, use good PCB layout practices, including:

- Noise can propagate into analog circuitry through the power pins of the circuit as a whole, as well as the operational amplifier. Bypass capacitors are used to reduce the coupled noise by providing low impedance power sources local to the analog circuitry.
 - Connect low-ESR, 0.1- μ F ceramic bypass capacitors between each supply pin and ground, placed as close to the device as possible. A single bypass capacitor from V+ to ground is applicable for single supply applications.
- Separate grounding for analog and digital portions of circuitry is one of the simplest and most-effective methods of noise suppression. One or more layers on multilayer PCBs are usually devoted to ground planes. A ground plane helps distribute heat and reduces EMI noise pickup. Make sure to physically separate digital and analog grounds, paying attention to the flow of the ground current.
- To reduce parasitic coupling, run the input traces as far away from the supply or output traces as possible. If it is not possible to keep them separate, it is much better to cross the sensitive trace perpendicular as opposed to in parallel with the noisy trace.
- Place the external components as close to the device as possible. Keeping RF and RG close to the inverting input minimizes parasitic capacitance.
- Keep the length of input traces as short as possible. Always remember that the input traces are the most sensitive part of the circuit.
- Consider a driven, low-impedance guard ring around the critical traces. A guard ring can significantly reduce leakage currents from nearby traces that are at different potentials.

11.2 Layout Example

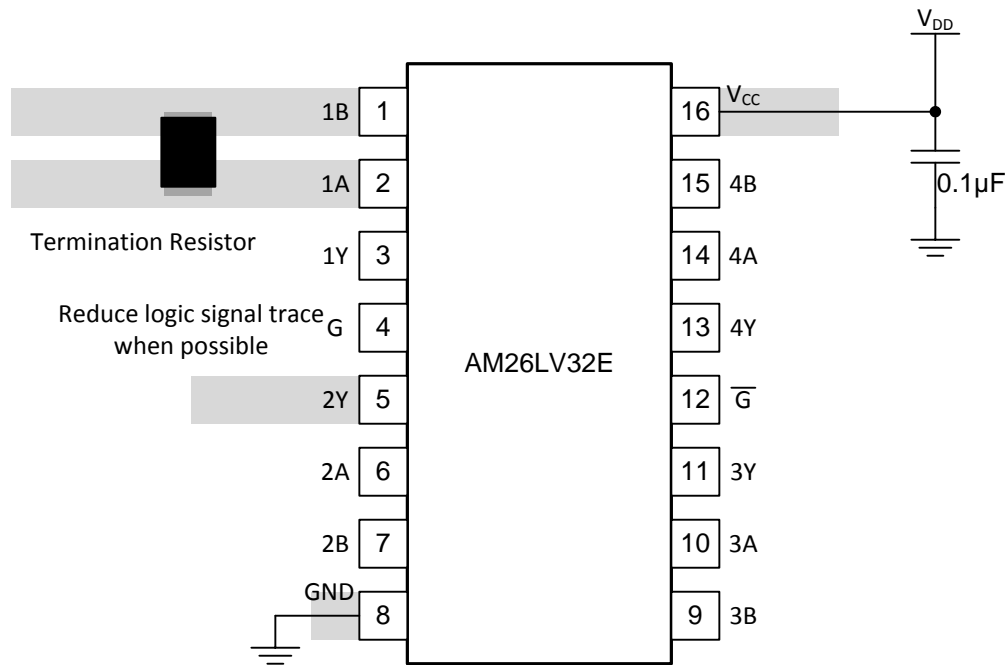

Figure 6. Trace Layout on PCB and Recommendations

12 Device and Documentation Support

12.1 Community Resources

The following links connect to TI community resources. Linked contents are provided "AS IS" by the respective contributors. They do not constitute TI specifications and do not necessarily reflect TI's views; see TI's [Terms of Use](#).

TI E2E™ Online Community *TI's Engineer-to-Engineer (E2E) Community*. Created to foster collaboration among engineers. At e2e.ti.com, you can ask questions, share knowledge, explore ideas and help solve problems with fellow engineers.

Design Support *TI's Design Support* Quickly find helpful E2E forums along with design support tools and contact information for technical support.

12.2 Trademarks

E2E is a trademark of Texas Instruments.
All other trademarks are the property of their respective owners.

12.3 Electrostatic Discharge Caution



These devices have limited built-in ESD protection. The leads should be shorted together or the device placed in conductive foam during storage or handling to prevent electrostatic damage to the MOS gates.

12.4 Glossary

[SLYZ022](#) — *TI Glossary*.

This glossary lists and explains terms, acronyms, and definitions.

13 Mechanical, Packaging, and Orderable Information

The following pages include mechanical, packaging, and orderable information. This information is the most current data available for the designated devices. This data is subject to change without notice and revision of this document. For browser-based versions of this data sheet, refer to the left-hand navigation.

PACKAGING INFORMATION

Orderable Device	Status (1)	Package Type	Package Drawing	Pins	Package Qty	Eco Plan (2)	Lead/Ball Finish (6)	MSL Peak Temp (3)	Op Temp (°C)	Device Marking (4/5)	Samples
AM26LV32EIDR	ACTIVE	SOIC	D	16	2500	Green (RoHS & no Sb/Br)	CU NIPDAU	Level-1-260C-UNLIM	-40 to 85	AM26LV32EI	Samples
AM26LV32EIDRG4	ACTIVE	SOIC	D	16	2500	Green (RoHS & no Sb/Br)	CU NIPDAU	Level-1-260C-UNLIM	-40 to 85	AM26LV32EI	Samples
AM26LV32EINSR	ACTIVE	SO	NS	16	2000	Green (RoHS & no Sb/Br)	CU NIPDAU	Level-1-260C-UNLIM	-40 to 85	26LV32EI	Samples
AM26LV32EIPWR	ACTIVE	TSSOP	PW	16	2000	Green (RoHS & no Sb/Br)	CU NIPDAU	Level-1-260C-UNLIM	-40 to 85	SB32	Samples
AM26LV32EIPWRG4	ACTIVE	TSSOP	PW	16	2000	Green (RoHS & no Sb/Br)	CU NIPDAU	Level-1-260C-UNLIM	-40 to 85	SB32	Samples
AM26LV32EIRGYR	ACTIVE	VQFN	RGY	16	3000	Green (RoHS & no Sb/Br)	CU NIPDAU	Level-2-260C-1 YEAR	-40 to 85	SB32	Samples
AM26LV32EIRGYRG4	ACTIVE	VQFN	RGY	16	3000	Green (RoHS & no Sb/Br)	CU NIPDAU	Level-2-260C-1 YEAR	-40 to 85	SB32	Samples

(1) The marketing status values are defined as follows:

ACTIVE: Product device recommended for new designs.

LIFEBUY: TI has announced that the device will be discontinued, and a lifetime-buy period is in effect.

NRND: Not recommended for new designs. Device is in production to support existing customers, but TI does not recommend using this part in a new design.

PREVIEW: Device has been announced but is not in production. Samples may or may not be available.

OBSELETE: TI has discontinued the production of the device.

(2) Eco Plan - The planned eco-friendly classification: Pb-Free (RoHS), Pb-Free (RoHS Exempt), or Green (RoHS & no Sb/Br) - please check <http://www.ti.com/productcontent> for the latest availability information and additional product content details.

TBD: The Pb-Free/Green conversion plan has not been defined.

Pb-Free (RoHS): TI's terms "Lead-Free" or "Pb-Free" mean semiconductor products that are compatible with the current RoHS requirements for all 6 substances, including the requirement that lead not exceed 0.1% by weight in homogeneous materials. Where designed to be soldered at high temperatures, TI Pb-Free products are suitable for use in specified lead-free processes.

Pb-Free (RoHS Exempt): This component has a RoHS exemption for either 1) lead-based flip-chip solder bumps used between the die and package, or 2) lead-based die adhesive used between the die and leadframe. The component is otherwise considered Pb-Free (RoHS compatible) as defined above.

Green (RoHS & no Sb/Br): TI defines "Green" to mean Pb-Free (RoHS compatible), and free of Bromine (Br) and Antimony (Sb) based flame retardants (Br or Sb do not exceed 0.1% by weight in homogeneous material)

(3) MSL, Peak Temp. - The Moisture Sensitivity Level rating according to the JEDEC industry standard classifications, and peak solder temperature.

(4) There may be additional marking, which relates to the logo, the lot trace code information, or the environmental category on the device.

⁽⁵⁾ Multiple Device Markings will be inside parentheses. Only one Device Marking contained in parentheses and separated by a "-" will appear on a device. If a line is indented then it is a continuation of the previous line and the two combined represent the entire Device Marking for that device.

⁽⁶⁾ Lead/Ball Finish - Orderable Devices may have multiple material finish options. Finish options are separated by a vertical ruled line. Lead/Ball Finish values may wrap to two lines if the finish value exceeds the maximum column width.

Important Information and Disclaimer:The information provided on this page represents TI's knowledge and belief as of the date that it is provided. TI bases its knowledge and belief on information provided by third parties, and makes no representation or warranty as to the accuracy of such information. Efforts are underway to better integrate information from third parties. TI has taken and continues to take reasonable steps to provide representative and accurate information but may not have conducted destructive testing or chemical analysis on incoming materials and chemicals. TI and TI suppliers consider certain information to be proprietary, and thus CAS numbers and other limited information may not be available for release.

In no event shall TI's liability arising out of such information exceed the total purchase price of the TI part(s) at issue in this document sold by TI to Customer on an annual basis.

OTHER QUALIFIED VERSIONS OF AM26LV32E :

- Enhanced Product: [AM26LV32E-EP](#)

NOTE: Qualified Version Definitions:

- Enhanced Product - Supports Defense, Aerospace and Medical Applications

TAPE AND REEL INFORMATION

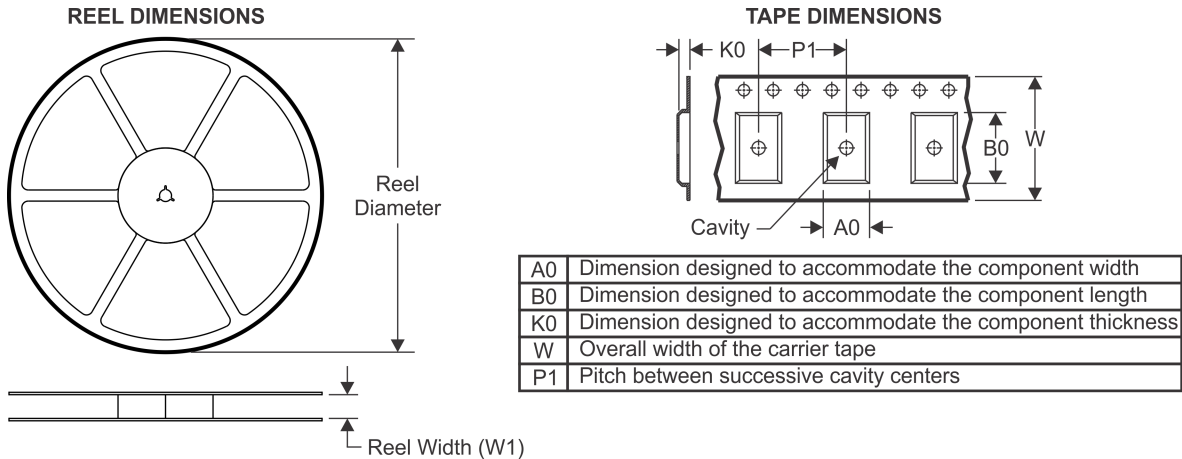

QUADRANT ASSIGNMENTS FOR PIN 1 ORIENTATION IN TAPE



*All dimensions are nominal

Device	Package Type	Package Drawing	Pins	SPQ	Reel Diameter (mm)	Reel Width W1 (mm)	A0 (mm)	B0 (mm)	K0 (mm)	P1 (mm)	W (mm)	Pin1 Quadrant
AM26LV32EIDR	SOIC	D	16	2500	330.0	16.4	6.5	10.3	2.1	8.0	16.0	Q1
AM26LV32EIPWR	TSSOP	PW	16	2000	330.0	12.4	6.9	5.6	1.6	8.0	12.0	Q1
AM26LV32EIRGYR	VQFN	RGY	16	3000	330.0	12.4	3.8	4.3	1.5	8.0	12.0	Q1

TAPE AND REEL BOX DIMENSIONS

*All dimensions are nominal

Device	Package Type	Package Drawing	Pins	SPQ	Length (mm)	Width (mm)	Height (mm)
AM26LV32EIDR	SOIC	D	16	2500	367.0	367.0	38.0
AM26LV32EIPWR	TSSOP	PW	16	2000	367.0	367.0	35.0
AM26LV32EIRGYR	VQFN	RGY	16	3000	367.0	367.0	35.0

D (R-PDSO-G16)

PLASTIC SMALL OUTLINE



4040047-6/M 06/11

- NOTES:
- A. All linear dimensions are in inches (millimeters).
 - B. This drawing is subject to change without notice.
 -  C. Body length does not include mold flash, protrusions, or gate burrs. Mold flash, protrusions, or gate burrs shall not exceed 0.006 (0,15) each side.
 -  D. Body width does not include interlead flash. Interlead flash shall not exceed 0.017 (0,43) each side.
 - E. Reference JEDEC MS-012 variation AC.

D (R-PDSO-G16)

PLASTIC SMALL OUTLINE



- NOTES:
- All linear dimensions are in millimeters.
 - This drawing is subject to change without notice.
 - Publication IPC-7351 is recommended for alternate designs.
 - Laser cutting apertures with trapezoidal walls and also rounding corners will offer better paste release. Customers should contact their board assembly site for stencil design recommendations. Refer to IPC-7525 for other stencil recommendations.
 - Customers should contact their board fabrication site for solder mask tolerances between and around signal pads.

PW (R-PDSO-G16)

PLASTIC SMALL OUTLINE

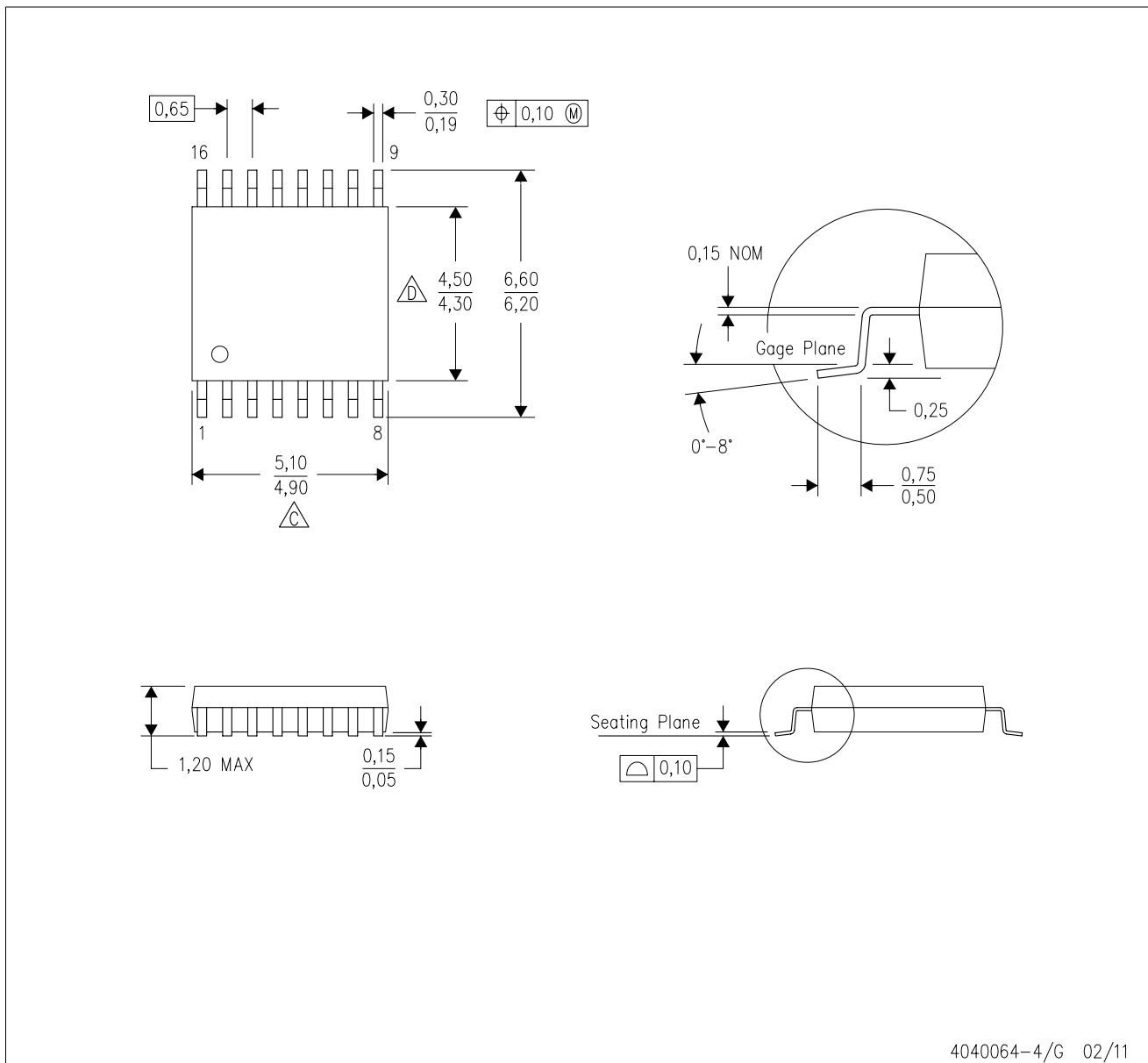

4040064-4/G 02/11

- NOTES:
- A. All linear dimensions are in millimeters. Dimensioning and tolerancing per ASME Y14.5M-1994.
 - B. This drawing is subject to change without notice.
 -  Body length does not include mold flash, protrusions, or gate burrs. Mold flash, protrusions, or gate burrs shall not exceed 0,15 each side.
 -  Body width does not include interlead flash. Interlead flash shall not exceed 0,25 each side.
 - E. Falls within JEDEC MO-153

PW (R-PDSO-G16)

PLASTIC SMALL OUTLINE

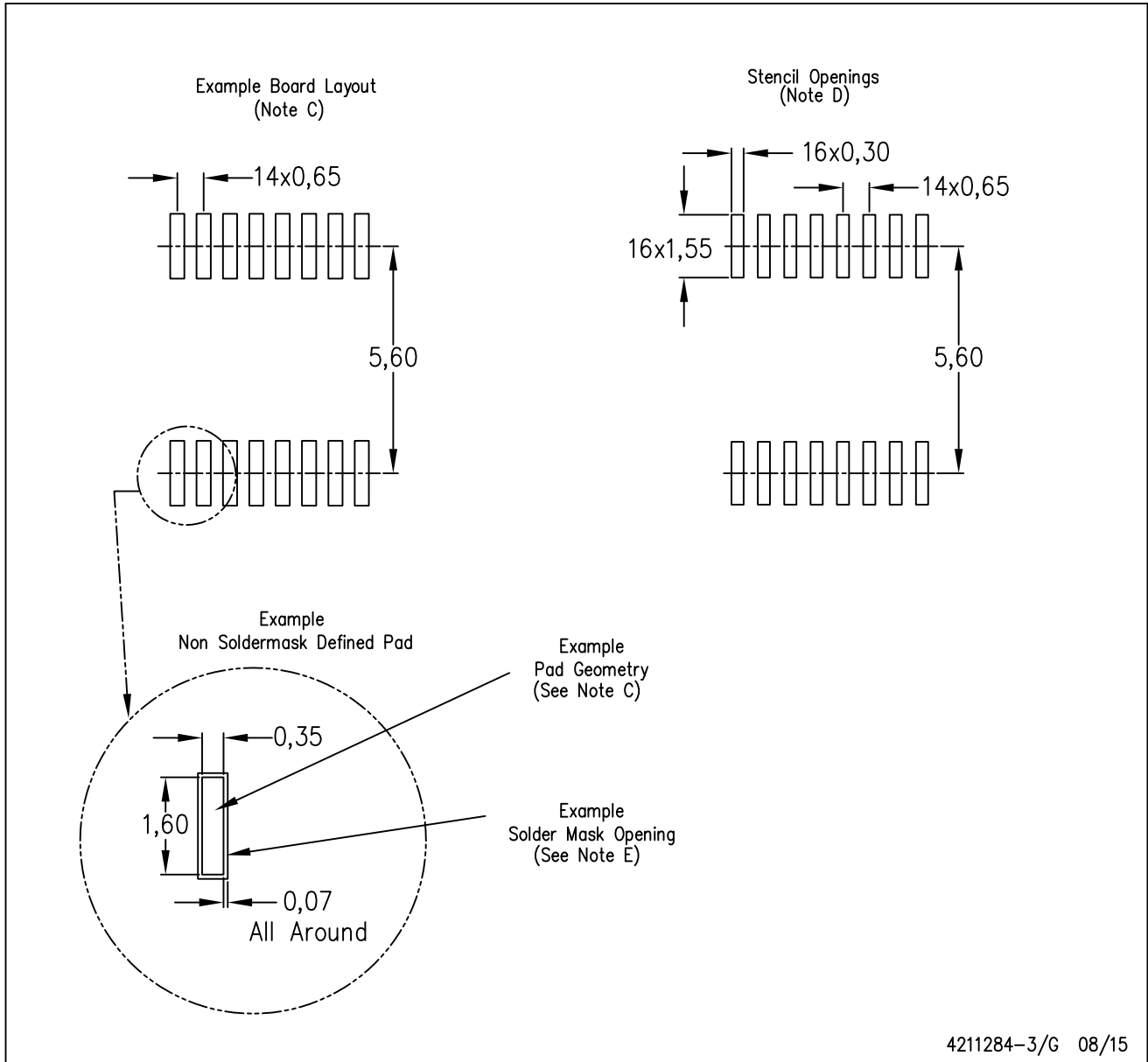

- NOTES:
- All linear dimensions are in millimeters.
 - This drawing is subject to change without notice.
 - Publication IPC-7351 is recommended for alternate designs.
 - Laser cutting apertures with trapezoidal walls and also rounding corners will offer better paste release. Customers should contact their board assembly site for stencil design recommendations. Refer to IPC-7525 for other stencil recommendations.
 - Customers should contact their board fabrication site for solder mask tolerances between and around signal pads.

RGY (R-PVQFN-N16)

PLASTIC QUAD FLATPACK NO-LEAD

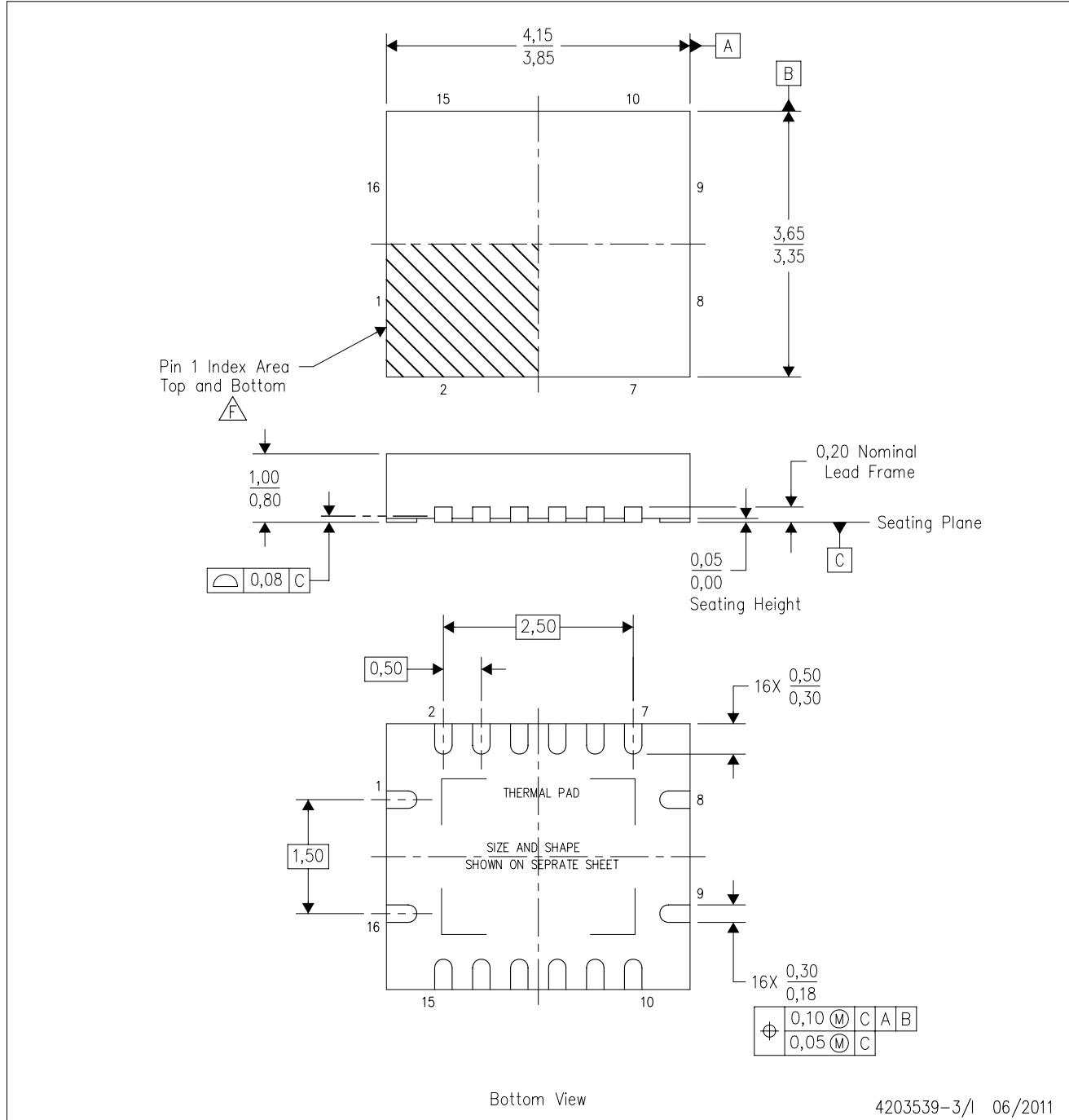

4203539-3/1 06/2011

- NOTES:
- All linear dimensions are in millimeters. Dimensioning and tolerancing per ASME Y14.5M-1994.
 - This drawing is subject to change without notice.
 - QFN (Quad Flatpack No-Lead) package configuration.
 - The package thermal pad must be soldered to the board for thermal and mechanical performance.
 - See the additional figure in the Product Data Sheet for details regarding the exposed thermal pad features and dimensions.
 - Pin 1 identifiers are located on both top and bottom of the package and within the zone indicated. The Pin 1 identifiers are either a molded, marked, or metal feature.
 - Package complies to JEDEC MO-241 variation BA.

RGY (R-PVQFN-N16)

PLASTIC QUAD FLATPACK NO-LEAD

THERMAL INFORMATION

This package incorporates an exposed thermal pad that is designed to be attached directly to an external heatsink. The thermal pad must be soldered directly to the printed circuit board (PCB). After soldering, the PCB can be used as a heatsink. In addition, through the use of thermal vias, the thermal pad can be attached directly to the appropriate copper plane shown in the electrical schematic for the device, or alternatively, can be attached to a special heatsink structure designed into the PCB. This design optimizes the heat transfer from the integrated circuit (IC).

For information on the Quad Flatpack No-Lead (QFN) package and its advantages, refer to Application Report, QFN/SON PCB Attachment, Texas Instruments Literature No. SLUA271. This document is available at www.ti.com.

The exposed thermal pad dimensions for this package are shown in the following illustration.



Bottom View

Exposed Thermal Pad Dimensions

4206353-3/P 03/14

NOTE: All linear dimensions are in millimeters

RGY (R-PVQFN-N16)

PLASTIC QUAD FLATPACK NO-LEAD



4208122-3/P 03/14

- NOTES:
- A. All linear dimensions are in millimeters.
 - B. This drawing is subject to change without notice.
 - C. Publication IPC-7351 is recommended for alternate designs.
 - D. This package is designed to be soldered to a thermal pad on the board. Refer to Application Note, Quad Flat-Pack QFN/SON PCB Attachment, Texas Instruments Literature No. SLUA271, and also the Product Data Sheets for specific thermal information, via requirements, and recommended board layout. These documents are available at www.ti.com <<http://www.ti.com>>.
 - E. Laser cutting apertures with trapezoidal walls and also rounding corners will offer better paste release. Customers should contact their board assembly site for stencil design recommendations. Refer to IPC 7525 for stencil design considerations.
 - F. Customers should contact their board fabrication site for minimum solder mask web tolerances between signal pads.

MECHANICAL DATA

NS (R-PDSO-G**)

PLASTIC SMALL-OUTLINE PACKAGE

14-PINS SHOWN



- NOTES:
- A. All linear dimensions are in millimeters.
 - B. This drawing is subject to change without notice.
 - C. Body dimensions do not include mold flash or protrusion, not to exceed 0,15.

IMPORTANT NOTICE

Texas Instruments Incorporated and its subsidiaries (TI) reserve the right to make corrections, enhancements, improvements and other changes to its semiconductor products and services per JESD46, latest issue, and to discontinue any product or service per JESD48, latest issue. Buyers should obtain the latest relevant information before placing orders and should verify that such information is current and complete. All semiconductor products (also referred to herein as "components") are sold subject to TI's terms and conditions of sale supplied at the time of order acknowledgment.

TI warrants performance of its components to the specifications applicable at the time of sale, in accordance with the warranty in TI's terms and conditions of sale of semiconductor products. Testing and other quality control techniques are used to the extent TI deems necessary to support this warranty. Except where mandated by applicable law, testing of all parameters of each component is not necessarily performed.

TI assumes no liability for applications assistance or the design of Buyers' products. Buyers are responsible for their products and applications using TI components. To minimize the risks associated with Buyers' products and applications, Buyers should provide adequate design and operating safeguards.

TI does not warrant or represent that any license, either express or implied, is granted under any patent right, copyright, mask work right, or other intellectual property right relating to any combination, machine, or process in which TI components or services are used. Information published by TI regarding third-party products or services does not constitute a license to use such products or services or a warranty or endorsement thereof. Use of such information may require a license from a third party under the patents or other intellectual property of the third party, or a license from TI under the patents or other intellectual property of TI.

Reproduction of significant portions of TI information in TI data books or data sheets is permissible only if reproduction is without alteration and is accompanied by all associated warranties, conditions, limitations, and notices. TI is not responsible or liable for such altered documentation. Information of third parties may be subject to additional restrictions.

Resale of TI components or services with statements different from or beyond the parameters stated by TI for that component or service voids all express and any implied warranties for the associated TI component or service and is an unfair and deceptive business practice. TI is not responsible or liable for any such statements.

Buyer acknowledges and agrees that it is solely responsible for compliance with all legal, regulatory and safety-related requirements concerning its products, and any use of TI components in its applications, notwithstanding any applications-related information or support that may be provided by TI. Buyer represents and agrees that it has all the necessary expertise to create and implement safeguards which anticipate dangerous consequences of failures, monitor failures and their consequences, lessen the likelihood of failures that might cause harm and take appropriate remedial actions. Buyer will fully indemnify TI and its representatives against any damages arising out of the use of any TI components in safety-critical applications.

In some cases, TI components may be promoted specifically to facilitate safety-related applications. With such components, TI's goal is to help enable customers to design and create their own end-product solutions that meet applicable functional safety standards and requirements. Nonetheless, such components are subject to these terms.

No TI components are authorized for use in FDA Class III (or similar life-critical medical equipment) unless authorized officers of the parties have executed a special agreement specifically governing such use.

Only those TI components which TI has specifically designated as military grade or "enhanced plastic" are designed and intended for use in military/aerospace applications or environments. Buyer acknowledges and agrees that any military or aerospace use of TI components which have **not** been so designated is solely at the Buyer's risk, and that Buyer is solely responsible for compliance with all legal and regulatory requirements in connection with such use.

TI has specifically designated certain components as meeting ISO/TS16949 requirements, mainly for automotive use. In any case of use of non-designated products, TI will not be responsible for any failure to meet ISO/TS16949.

Products

Audio	www.ti.com/audio
Amplifiers	amplifier.ti.com
Data Converters	dataconverter.ti.com
DLP® Products	www.dlp.com
DSP	dsp.ti.com
Clocks and Timers	www.ti.com/clocks
Interface	interface.ti.com
Logic	logic.ti.com
Power Mgmt	power.ti.com
Microcontrollers	microcontroller.ti.com
RFID	www.ti-rfid.com
OMAP Applications Processors	www.ti.com/omap
Wireless Connectivity	www.ti.com/wirelessconnectivity

Applications

Automotive and Transportation	www.ti.com/automotive
Communications and Telecom	www.ti.com/communications
Computers and Peripherals	www.ti.com/computers
Consumer Electronics	www.ti.com/consumer-apps
Energy and Lighting	www.ti.com/energy
Industrial	www.ti.com/industrial
Medical	www.ti.com/medical
Security	www.ti.com/security
Space, Avionics and Defense	www.ti.com/space-avionics-defense
Video and Imaging	www.ti.com/video

TI E2E Community

e2e.ti.com