

LM4040-N/LM4040Q-N Precision Micropower Shunt Voltage Reference

Check for Samples: [LM4040-N](#), [LM4040Q-N](#)

FEATURES

- 2.5V/SOT-23 AEC Q-100 Grades 1 and 3 available
- Small packages: SOT-23, TO-92 and SC70
- No output capacitor required
- Tolerates capacitive loads
- Fixed reverse breakdown voltages of 2.048V, 2.500V, 3.000V, 4.096V, 5.000V, 8.192V, and 10.000V

APPLICATIONS

- Portable, Battery-Powered Equipment
- Data Acquisition Systems
- Instrumentation
- Process Control
- Energy Management
- Product Testing
- Automotive
- Precision Audio Components

DESCRIPTION

Ideal for space critical applications, the LM4040 precision voltage reference is available in the sub-miniature SC70 and SOT-23 surface-mount package. The LM4040's advanced design eliminates the need for an external stabilizing capacitor while ensuring stability with any capacitive load, thus making the LM4040 easy to use. Further reducing design effort is the availability of several fixed reverse breakdown voltages: 2.048V, 2.500V, 3.000V, 4.096V, 5.000V, 8.192V, and 10.000V. The minimum operating current increases from 60 μ A for the LM4040-2.5 to 100 μ A for the LM4040-10.0. All versions have a maximum operating current of 15 mA.

The LM4040 utilizes fuse and zener-zap reverse breakdown voltage trim during wafer sort to ensure that the prime parts have an accuracy of better than $\pm 0.1\%$ (A grade) at 25°C. Bandgap reference temperature drift curvature correction and low dynamic impedance ensure stable reverse breakdown voltage accuracy over a wide range of operating temperatures and currents.

Also available is the LM4041 with two reverse breakdown voltage versions: adjustable and 1.2V. Please see the LM4041 data sheet.

Table 1. Key Specifications (LM4040-2.5)

	VALUE	UNIT
■ Output voltage tolerance (A grade, 25°C)	$\pm 0.1\%$ (max)	
■ Low output noise (10 Hz to 10 kHz)	35 μ V _{rms} (typ)	
■ Wide operating current range	60 μ A to 15 mA	
■ Industrial temperature range	-40°C to +85°C	
■ Extended temperature range	-40°C to +125°C	
■ Low temperature coefficient	100 ppm/°C (max)	

Connection Diagrams

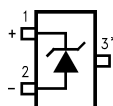

*This pin must be left floating or connected to pin 2.

Figure 1. SOT-23 NS Package (Top View)

Please be aware that an important notice concerning availability, standard warranty, and use in critical applications of Texas Instruments semiconductor products and disclaimers thereto appears at the end of this data sheet.

All trademarks are the property of their respective owners.

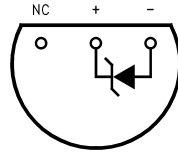
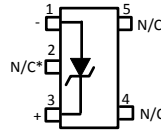

Figure 2. TO-92 NS Package(Bottom View)



*This pin must be left floating or connected to pin 1.

Figure 3. SC70 NS Package (Top View)

SOT-23 AND SC70 Package Marking Information

Only three fields of marking are possible on the SOT-23's and SC70's small surface. This table gives the meaning of the three fields.

First Field: R = Reference	
Second Field: Voltage Option J = 2.048V Voltage Option 2 = 2.500V Voltage Option K = 3.000V Voltage Option 4 = 4.096V Voltage Option 5 = 5.000V Voltage Option 8 = 8.192V Voltage Option 0 = 10.000V Voltage Option	
Third Field: Initial Reverse Breakdown Voltage or Reference Voltage Tolerance A = $\pm 0.1\%$ B = $\pm 0.2\%$ C = $\pm 0.5\%$ D = $\pm 1.0\%$ E = $\pm 2.0\%$	
Part Marking	Field Definition
RJA (SOT-23 only)	Reference, 2.048V, $\pm 0.1\%$
R2A (SOT-23 only)	Reference, 2.500V, $\pm 0.1\%$
RKA (SOT-23 only)	Reference, 3.000V, $\pm 0.1\%$
R4A (SOT-23 only)	Reference, 4.096V, $\pm 0.1\%$
R5A (SOT-23 only)	Reference, 5.000V, $\pm 0.1\%$
R8A (SOT-23 only)	Reference, 8.192V, $\pm 0.1\%$
R0A (SOT-23 only)	Reference, 10.000V, $\pm 0.1\%$
RJB	Reference, 2.048V, $\pm 0.2\%$
R2B	Reference, 2.500V, $\pm 0.2\%$
RKB	Reference, 3.000V, $\pm 0.2\%$
R4B	Reference, 4.096V, $\pm 0.2\%$
R5B	Reference, 5.000V, $\pm 0.2\%$
R8B (SOT-23 only)	Reference, 8.192V, $\pm 0.2\%$
R0B (SOT-23 only)	Reference, 10.000V, $\pm 0.2\%$
RJC	Reference, 2.048V, $\pm 0.5\%$
R2C	Reference, 2.500V, $\pm 0.5\%$

RKC	Reference, 3.000V, $\pm 0.5\%$
R4C	Reference, 4.096V, $\pm 0.5\%$
R5C	Reference, 5.000V, $\pm 0.5\%$
R8C (SOT-23 only)	Reference, 8.192V, $\pm 0.5\%$
R0C (SOT-23 only)	Reference, 10.000V, $\pm 0.5\%$
RJD	Reference, 2.048V, $\pm 1.0\%$
R2D	Reference, 2.500V, $\pm 1.0\%$
RKD	Reference, 3.000V, $\pm 1.0\%$
R4D	Reference, 4.096V, $\pm 1.0\%$
R5D	Reference, 5.000V, $\pm 1.0\%$
R8D (SOT-23 only)	Reference, 8.192V, $\pm 1.0\%$
R0D (SOT-23 only)	Reference, 10.000V, $\pm 1.0\%$
RJE	Reference, 2.048V, $\pm 2.0\%$
R2E	Reference, 2.500V, $\pm 2.0\%$
RKE	Reference, 3.000V, $\pm 2.0\%$



These devices have limited built-in ESD protection. The leads should be shorted together or the device placed in conductive foam during storage or handling to prevent electrostatic damage to the MOS gates.

Absolute Maximum Ratings ⁽¹⁾

Reverse Current	20 mA
Forward Current	10 mA
Power Dissipation ($T_A = 25^\circ\text{C}$) ⁽²⁾	
SOT-23 (M3) Package	306 mW
TO-92 (Z) Package	550 mW
SC-70 (M7) Package	241 mW
Storage Temperature	-65°C to $+150^\circ\text{C}$
Soldering Temperature ⁽³⁾	
SOT-23 (M3) Package	
Peak Reflow (30 sec)	$+260^\circ\text{C}$
TO-92 (Z) Package	
Soldering (10 sec)	$+260^\circ\text{C}$
SC-70 (M7) Package	
Peak Reflow (30 sec)	$+260^\circ\text{C}$
ESD Susceptibility	
Human Body Model ⁽⁴⁾	2 kV
Machine Model ⁽⁴⁾	200V

- (1) Absolute Maximum Ratings indicate limits beyond which damage to the device may occur. Operating Ratings indicate conditions for which the device is functional, but do not guarantee specific performance limits. For guaranteed specifications and test conditions, see the Electrical Characteristics. The guaranteed specifications apply only for the test conditions listed. Some performance characteristics may degrade when the device is not operated under the listed test conditions.
- (2) The maximum power dissipation must be derated at elevated temperatures and is dictated by T_{Jmax} (maximum junction temperature), θ_{JA} (junction to ambient thermal resistance), and T_A (ambient temperature). The maximum allowable power dissipation at any temperature is $PD_{max} = (T_{Jmax} - T_A)/\theta_{JA}$ or the number given in the Absolute Maximum Ratings, whichever is lower. For the LM4040, $T_{Jmax} = 125^\circ\text{C}$, and the typical thermal resistance (θ_{JA}), when board mounted, is $326^\circ\text{C}/\text{W}$ for the SOT-23 package, and $180^\circ\text{C}/\text{W}$ with 0.4" lead length and $170^\circ\text{C}/\text{W}$ with 0.125" lead length for the TO-92 package and $415^\circ\text{C}/\text{W}$ for the SC70 Package.
- (3) Peak Reflow Temperatures for Surface Mount devices are defined in "Absolute Maximum Ratings for Soldering", Literature Number: SNOA549C
- (4) The human body model is a 100 pF capacitor discharged through a 1.5 k Ω resistor into each pin. The machine model is a 200 pF capacitor discharged directly into each pin.

Operating Ratings ⁽¹⁾ ⁽²⁾

Temperature Range	($T_{\min} \leq T_A \leq T_{\max}$)
Industrial Temperature Range	$-40^{\circ}\text{C} \leq T_A \leq +85^{\circ}\text{C}$
Extended Temperature Range	$-40^{\circ}\text{C} \leq T_A \leq +125^{\circ}\text{C}$
Reverse Current	
LM4040-2.0	60 μA to 15 mA
LM4040-2.5	60 μA to 15 mA
LM4040-3.0	62 μA to 15 mA
LM4040-4.1	68 μA to 15 mA
LM4040-5.0	74 μA to 15 mA
LM4040-8.2	91 μA to 15 mA
LM4040-10.0	100 μA to 15 mA

- (1) Absolute Maximum Ratings indicate limits beyond which damage to the device may occur. Operating Ratings indicate conditions for which the device is functional, but do not guarantee specific performance limits. For guaranteed specifications and test conditions, see the Electrical Characteristics. The guaranteed specifications apply only for the test conditions listed. Some performance characteristics may degrade when the device is not operated under the listed test conditions.
- (2) The maximum power dissipation must be derated at elevated temperatures and is dictated by $T_{J\max}$ (maximum junction temperature), θ_{JA} (junction to ambient thermal resistance), and T_A (ambient temperature). The maximum allowable power dissipation at any temperature is $PD_{\max} = (T_{J\max} - T_A)/\theta_{JA}$ or the number given in the Absolute Maximum Ratings, whichever is lower. For the LM4040, $T_{J\max} = 125^{\circ}\text{C}$, and the typical thermal resistance (θ_{JA}), when board mounted, is $326^{\circ}\text{C}/\text{W}$ for the SOT-23 package, and $180^{\circ}\text{C}/\text{W}$ with 0.4" lead length and $170^{\circ}\text{C}/\text{W}$ with 0.125" lead length for the TO-92 package and $415^{\circ}\text{C}/\text{W}$ for the SC70 Package.

LM4040-2.0 Electrical Characteristics

V_R Tolerance Grades 'A' and 'B'; Temperature Grade 'I'

Boldface limits apply for $T_A = T_J = T_{MIN}$ to T_{MAX} ; all other limits $T_A = T_J = 25^\circ\text{C}$. The grades A and B designate initial Reverse Breakdown Voltage tolerances of $\pm 0.1\%$ and $\pm 0.2\%$, respectively.

Symbol	Parameter	Conditions	Typical (1)	LM4040AIM3 LM4040AIZ — Limits (2)	LM4040BIM3 LM4040BIZ LM4040BIM7 Limits (2)	Units
V_R	Reverse Breakdown Voltage	$I_R = 100\ \mu\text{A}$	2.048			V
	Reverse Breakdown Voltage Tolerance (3)	$I_R = 100\ \mu\text{A}$		± 2.0	± 4.1	mV (max)
I_{RMIN}	Minimum Operating Current		45			μA
				60	60	μA (max)
				65	65	μA (max)
$\Delta V_R/\Delta T$	Average Reverse Breakdown Voltage Temperature Coefficient (3)	$I_R = 10\ \text{mA}$	± 20			ppm/ $^\circ\text{C}$
		$I_R = 1\ \text{mA}$	± 15	± 100	± 100	ppm/ $^\circ\text{C}$ (max)
		$I_R = 100\ \mu\text{A}$	± 15			ppm/ $^\circ\text{C}$
$\Delta V_R/\Delta I_R$	Reverse Breakdown Voltage Change with Operating Current Change (4)	$I_{RMIN} \leq I_R \leq 1\ \text{mA}$	0.3			mV
				0.8	0.8	mV (max)
				1.0	1.0	mV (max)
		$1\ \text{mA} \leq I_R \leq 15\ \text{mA}$	2.5			mV
				6.0	6.0	mV (max)
		8.0	8.0	mV (max)		
Z_R	Reverse Dynamic Impedance	$I_R = 1\ \text{mA}$, $f = 120\ \text{Hz}$, $I_{AC} = 0.1\ I_R$	0.3			Ω
				0.8	0.8	Ω (max)
e_N	Wideband Noise	$I_R = 100\ \mu\text{A}$ $10\ \text{Hz} \leq f \leq 10\ \text{kHz}$	35			μV_{rms}
ΔV_R	Reverse Breakdown Voltage Long Term Stability	$t = 1000\ \text{hrs}$ $T = 25^\circ\text{C} \pm 0.1^\circ\text{C}$ $I_R = 100\ \mu\text{A}$	120			ppm

(1) Typicals are at $T_J = 25^\circ\text{C}$ and represent most likely parametric norm.

(2) Limits are 100% production tested at 25°C . Limits over temperature are guaranteed through correlation using Statistical Quality Control (SQC) methods. The limits are used to calculate National's AOQL.

(3) The boldface (over-temperature) limit for Reverse Breakdown Voltage Tolerance is defined as the room temperature Reverse Breakdown Voltage Tolerance $\pm[(\Delta V_R/\Delta T)(\text{max}\Delta T)(V_R)]$. Where, $\Delta V_R/\Delta T$ is the V_R temperature coefficient, $\text{max}\Delta T$ is the maximum difference in temperature from the reference point of 25°C to T_{MIN} or T_{MAX} , and V_R is the reverse breakdown voltage. The total over-temperature tolerance for the different grades in the industrial temperature range where $\text{max}\Delta T = 65^\circ\text{C}$ is shown below:

$$\text{A-grade: } \pm 0.75\% = \pm 0.1\% \pm 100\ \text{ppm}/^\circ\text{C} \times 65^\circ\text{C}$$

$$\text{B-grade: } \pm 0.85\% = \pm 0.2\% \pm 100\ \text{ppm}/^\circ\text{C} \times 65^\circ\text{C}$$

$$\text{C-grade: } \pm 1.15\% = \pm 0.5\% \pm 100\ \text{ppm}/^\circ\text{C} \times 65^\circ\text{C}$$

$$\text{D-grade: } \pm 1.98\% = \pm 1.0\% \pm 150\ \text{ppm}/^\circ\text{C} \times 65^\circ\text{C}$$

$$\text{E-grade: } \pm 2.98\% = \pm 2.0\% \pm 150\ \text{ppm}/^\circ\text{C} \times 65^\circ\text{C}$$

The total over-temperature tolerance for the different grades in the extended temperature range where $\text{max}\Delta T = 100^\circ\text{C}$ is shown below:

$$\text{C-grade: } \pm 1.5\% = \pm 0.5\% \pm 100\ \text{ppm}/^\circ\text{C} \times 100^\circ\text{C}$$

$$\text{D-grade: } \pm 2.5\% = \pm 1.0\% \pm 150\ \text{ppm}/^\circ\text{C} \times 100^\circ\text{C}$$

$$\text{E-grade: } \pm 3.5\% = \pm 2.0\% \pm 150\ \text{ppm}/^\circ\text{C} \times 100^\circ\text{C}$$

, as an example, the A-grade LM4040-2.5 has an over-temperature Reverse Breakdown Voltage tolerance of $\pm 2.5\% \times 0.75\% = \pm 19\ \text{mV}$.

(4) Load regulation is measured on pulse basis from no load to the specified load current. Output changes due to die temperature change must be taken into account separately.

LM4040-2.0 Electrical Characteristics

V_R Tolerance Grades 'A' and 'B'; Temperature Grade 'I' (continued)

Boldface limits apply for $T_A = T_J = T_{MIN}$ to T_{MAX} ; all other limits $T_A = T_J = 25^\circ\text{C}$. The grades A and B designate initial Reverse Breakdown Voltage tolerances of $\pm 0.1\%$ and $\pm 0.2\%$, respectively.

Symbol	Parameter	Conditions	Typical (1)	LM4040AIM3 LM4040AIZ — Limits (2)	LM4040BIM3 LM4040BIZ LM4040BIM7 Limits (2)	Units
V_{HYST}	Thermal Hysteresis (5)	$\Delta T = -40^\circ\text{C}$ to $+125^\circ\text{C}$	0.08			%

- (5) Thermal hysteresis is defined as the difference in voltage measured at $+25^\circ\text{C}$ after cycling to temperature -40°C and the 25°C measurement after cycling to temperature $+125^\circ\text{C}$.

LM4040-2.0 Electrical Characteristics

V_R Tolerance Grades 'C', 'D', and 'E'; Temperature Grade 'I'

Boldface limits apply for $T_A = T_J = T_{MIN}$ to T_{MAX} ; all other limits $T_A = T_J = 25^\circ\text{C}$. The grades C, D and E designate initial Reverse Breakdown Voltage tolerances of $\pm 0.5\%$, $\pm 1.0\%$ and $\pm 2.0\%$, respectively.

Symbol	Parameter	Conditions	Typical (1)	LM4040CIM3 LM4040CIZ LM4040CIM7 Limits (2)	LM4040DIM3 LM4040DIZ LM4040DIM7 Limits (2)	— LM4040EIZ LM4040EIM7 Limits (2)	Units
V_R	Reverse Breakdown Voltage	$I_R = 100 \mu\text{A}$	2.048				V
	Reverse Breakdown Voltage Tolerance (3)	$I_R = 100 \mu\text{A}$		± 10	± 20	± 41	mV (max)
I_{RMIN}	Minimum Operating Current		45				μA
			60	65	65	μA (max)	
			65	70	70	μA (max)	
$\Delta V_R/\Delta T$	Average Reverse Breakdown Voltage Temperature Coefficient (3)	$I_R = 10 \text{ mA}$	± 20				ppm/ $^\circ\text{C}$
		$I_R = 1 \text{ mA}$	± 15	± 100	± 150	± 150	ppm/ $^\circ\text{C}$ (max)
		$I_R = 100 \mu\text{A}$	± 15				ppm/ $^\circ\text{C}$
$\Delta V_R/\Delta I_R$	Reverse Breakdown Voltage Change with Operating Current Change (4)	$I_{RMIN} \leq I_R \leq 1 \text{ mA}$	0.3				mV
			0.8	1.0	1.0	mV (max)	
		$1 \text{ mA} \leq I_R \leq 15 \text{ mA}$	1.0	1.2	1.2	mV (max)	
			2.5			mV	
			6.0	8.0	8.0	mV (max)	
	8.0	10.0	10.0	mV (max)			
Z_R	Reverse Dynamic Impedance	$I_R = 1 \text{ mA}$, $f = 120 \text{ Hz}$ $I_{AC} = 0.1 I_R$	0.3				Ω
			0.9	1.1	1.1	Ω (max)	
e_N	Wideband Noise	$I_R = 100 \mu\text{A}$ $10 \text{ Hz} \leq f \leq 10 \text{ kHz}$	35				μV_{rms}

(1) Typicals are at $T_J = 25^\circ\text{C}$ and represent most likely parametric norm.

(2) Limits are 100% production tested at 25°C . Limits over temperature are guaranteed through correlation using Statistical Quality Control (SQC) methods. The limits are used to calculate National's AOQL.

(3) The boldface (over-temperature) limit for Reverse Breakdown Voltage Tolerance is defined as the room temperature Reverse Breakdown Voltage Tolerance $\pm[(\Delta V_R/\Delta T)(\text{max}\Delta T)(V_R)]$. Where, $\Delta V_R/\Delta T$ is the V_R temperature coefficient, $\text{max}\Delta T$ is the maximum difference in temperature from the reference point of 25°C to T_{MIN} or T_{MAX} , and V_R is the reverse breakdown voltage. The total over-temperature tolerance for the different grades in the industrial temperature range where $\text{max}\Delta T = 65^\circ\text{C}$ is shown below:

$$\text{A-grade: } \pm 0.75\% = \pm 0.1\% \pm 100 \text{ ppm}/^\circ\text{C} \times 65^\circ\text{C}$$

$$\text{B-grade: } \pm 0.85\% = \pm 0.2\% \pm 100 \text{ ppm}/^\circ\text{C} \times 65^\circ\text{C}$$

$$\text{C-grade: } \pm 1.15\% = \pm 0.5\% \pm 100 \text{ ppm}/^\circ\text{C} \times 65^\circ\text{C}$$

$$\text{D-grade: } \pm 1.98\% = \pm 1.0\% \pm 150 \text{ ppm}/^\circ\text{C} \times 65^\circ\text{C}$$

$$\text{E-grade: } \pm 2.98\% = \pm 2.0\% \pm 150 \text{ ppm}/^\circ\text{C} \times 65^\circ\text{C}$$

The total over-temperature tolerance for the different grades in the extended temperature range where $\text{max}\Delta T = 100^\circ\text{C}$ is shown below:

$$\text{C-grade: } \pm 1.5\% = \pm 0.5\% \pm 100 \text{ ppm}/^\circ\text{C} \times 100^\circ\text{C}$$

$$\text{D-grade: } \pm 2.5\% = \pm 1.0\% \pm 150 \text{ ppm}/^\circ\text{C} \times 100^\circ\text{C}$$

$$\text{E-grade: } \pm 3.5\% = \pm 2.0\% \pm 150 \text{ ppm}/^\circ\text{C} \times 100^\circ\text{C}$$

, as an example, the A-grade LM4040-2.5 has an over-temperature Reverse Breakdown Voltage tolerance of $\pm 2.5\text{V} \times 0.75\% = \pm 19 \text{ mV}$.

(4) Load regulation is measured on pulse basis from no load to the specified load current. Output changes due to die temperature change must be taken into account separately.

LM4040-2.0 Electrical Characteristics

V_R Tolerance Grades 'C', 'D', and 'E'; Temperature Grade 'I' (continued)

Boldface limits apply for $T_A = T_J = T_{MIN}$ to T_{MAX} ; all other limits $T_A = T_J = 25^\circ\text{C}$. The grades C, D and E designate initial Reverse Breakdown Voltage tolerances of $\pm 0.5\%$, $\pm 1.0\%$ and $\pm 2.0\%$, respectively.

Symbol	Parameter	Conditions	Typical (1)	LM4040CIM3 LM4040CIZ LM4040CIM7 Limits (2)	LM4040DIM3 LM4040DIZ LM4040DIM7 Limits (2)	— LM4040EIZ LM4040EIM7 Limits (2)	Units
ΔV_R	Reverse Breakdown Voltage Long Term Stability	t = 1000 hrs T = $25^\circ\text{C} \pm 0.1^\circ\text{C}$ $I_R = 100 \mu\text{A}$	120				ppm
V_{HYST}	Thermal Hysteresis (5)	$\Delta T = -40^\circ\text{C}$ to $+125^\circ\text{C}$	0.08				%

(5) Thermal hysteresis is defined as the difference in voltage measured at $+25^\circ\text{C}$ after cycling to temperature -40°C and the 25°C measurement after cycling to temperature $+125^\circ\text{C}$.

LM4040-2.0 Electrical Characteristics

V_R Tolerance Grades 'C', 'D', and 'E'; Temperature Grade 'E'

Boldface limits apply for $T_A = T_J = T_{MIN}$ to T_{MAX} ; all other limits $T_A = T_J = 25^\circ\text{C}$. The grades C, D and E designate initial Reverse Breakdown Voltage tolerances of $\pm 0.5\%$, $\pm 1.0\%$ and $\pm 2.0\%$, respectively.

Symbol	Parameter	Conditions	Typical (1)	LM4040CEM3 Limits (2)	LM4040DEM3 Limits (2)	LM4040EEM3 Limits (2)	Units
V_R	Reverse Breakdown Voltage	$I_R = 100 \mu\text{A}$	2.048				V
	Reverse Breakdown Voltage Tolerance ⁽³⁾	$I_R = 100 \mu\text{A}$		± 10	± 20	± 41	mV (max)
I_{RMIN}	Minimum Operating Current		45				μA
			60	65	65	μA (max)	
			68	73	73	μA (max)	
$\Delta V_R/\Delta T$	Average Reverse Breakdown Voltage Temperature Coefficient ⁽³⁾	$I_R = 10 \text{ mA}$	± 20				ppm/ $^\circ\text{C}$
		$I_R = 1 \text{ mA}$	± 15	± 100	± 150	± 150	ppm/ $^\circ\text{C}$ (max)
		$I_R = 100 \mu\text{A}$	± 15				ppm/ $^\circ\text{C}$
$\Delta V_R/\Delta I_R$	Reverse Breakdown Voltage Change with Operating Current Change ⁽⁴⁾	$I_{RMIN} \leq I_R \leq 1 \text{ mA}$	0.3				mV
			0.8	1.0	1.0	mV (max)	
			1.0	1.2	1.2	mV (max)	
		$1 \text{ mA} \leq I_R \leq 15 \text{ mA}$	2.5				mV
			6.0	8.0	8.0	mV (max)	
	8.0	10.0	10.0	mV (max)			
Z_R	Reverse Dynamic Impedance	$I_R = 1 \text{ mA}$, $f = 120 \text{ Hz}$, $I_{AC} = 0.1 I_R$	0.3				Ω
				0.9	1.1	1.1	Ω (max)
e_N	Wideband Noise	$I_R = 100 \mu\text{A}$ $10 \text{ Hz} \leq f \leq 10 \text{ kHz}$	35				μV_{rms}
ΔV_R	Reverse Breakdown Voltage Long Term Stability	$t = 1000 \text{ hrs}$ $T = 25^\circ\text{C} \pm 0.1^\circ\text{C}$ $I_R = 100 \mu\text{A}$	120				ppm

(1) Typicals are at $T_J = 25^\circ\text{C}$ and represent most likely parametric norm.

(2) Limits are 100% production tested at 25°C . Limits over temperature are guaranteed through correlation using Statistical Quality Control (SQC) methods. The limits are used to calculate National's AOQL.

(3) The boldface (over-temperature) limit for Reverse Breakdown Voltage Tolerance is defined as the room temperature Reverse Breakdown Voltage Tolerance $\pm[(\Delta V_R/\Delta T)(\max\Delta T)(V_R)]$. Where, $\Delta V_R/\Delta T$ is the V_R temperature coefficient, $\max\Delta T$ is the maximum difference in temperature from the reference point of 25°C to T_{MIN} or T_{MAX} , and V_R is the reverse breakdown voltage. The total over-temperature tolerance for the different grades in the industrial temperature range where $\max\Delta T = 65^\circ\text{C}$ is shown below:

$$\text{A-grade: } \pm 0.75\% = \pm 0.1\% \pm 100 \text{ ppm}/^\circ\text{C} \times 65^\circ\text{C}$$

$$\text{B-grade: } \pm 0.85\% = \pm 0.2\% \pm 100 \text{ ppm}/^\circ\text{C} \times 65^\circ\text{C}$$

$$\text{C-grade: } \pm 1.15\% = \pm 0.5\% \pm 100 \text{ ppm}/^\circ\text{C} \times 65^\circ\text{C}$$

$$\text{D-grade: } \pm 1.98\% = \pm 1.0\% \pm 150 \text{ ppm}/^\circ\text{C} \times 65^\circ\text{C}$$

$$\text{E-grade: } \pm 2.98\% = \pm 2.0\% \pm 150 \text{ ppm}/^\circ\text{C} \times 65^\circ\text{C}$$

The total over-temperature tolerance for the different grades in the extended temperature range where $\max\Delta T = 100^\circ\text{C}$ is shown below:

$$\text{C-grade: } \pm 1.5\% = \pm 0.5\% \pm 100 \text{ ppm}/^\circ\text{C} \times 100^\circ\text{C}$$

$$\text{D-grade: } \pm 2.5\% = \pm 1.0\% \pm 150 \text{ ppm}/^\circ\text{C} \times 100^\circ\text{C}$$

$$\text{E-grade: } \pm 3.5\% = \pm 2.0\% \pm 150 \text{ ppm}/^\circ\text{C} \times 100^\circ\text{C}$$

, as an example, the A-grade LM4040-2.5 has an over-temperature Reverse Breakdown Voltage tolerance of $\pm 2.5\% \times 0.75\% = \pm 19 \text{ mV}$.

(4) Load regulation is measured on pulse basis from no load to the specified load current. Output changes due to die temperature change must be taken into account separately.

LM4040-2.0 Electrical Characteristics**V_R Tolerance Grades 'C', 'D', and 'E'; Temperature Grade 'E' (continued)**

Boldface limits apply for T_A = T_J = T_{MIN} to T_{MAX}; all other limits T_A = T_J = 25°C. The grades C, D and E designate initial Reverse Breakdown Voltage tolerances of ±0.5%, ±1.0% and ±2.0%, respectively.

Symbol	Parameter	Conditions	Typical (1)	LM4040CEM3 Limits (2)	LM4040DEM3 Limits (2)	LM4040EEM3 Limits (2)	Units
V _{HYST}	Thermal Hysteresis (5)	ΔT = -40°C to +125°C	0.08				%

- (5) Thermal hysteresis is defined as the difference in voltage measured at +25°C after cycling to temperature -40°C and the 25°C measurement after cycling to temperature +125°C.

LM4040-2.5 Electrical Characteristics

V_R Tolerance Grades 'A' and 'B'; Temperature Grade 'I' (AEC Grade 3)

Boldface limits apply for $T_A = T_J = T_{MIN}$ to T_{MAX} ; all other limits $T_A = T_J = 25^\circ\text{C}$. The grades A and B designate initial Reverse Breakdown Voltage tolerances of $\pm 0.1\%$ and $\pm 0.2\%$, respectively.

Symbol	Parameter	Conditions	Typical (1)	LM4040AIM3	LM4040BIM3	Units
				LM4040AIZ	LM4040BIZ	
				—	LM4040BIM7	
				LM4040QAIM3	LM4040QBIM3	
				Limits (2)	Limits (2)	
V_R	Reverse Breakdown Voltage	$I_R = 100 \mu\text{A}$	2.500			V
	Reverse Breakdown Voltage Tolerance (3)	$I_R = 100 \mu\text{A}$		± 2.5	± 5.0	mV (max)
I_{RMIN}	Minimum Operating Current		45			μA
				60	60	μA (max)
				65	65	μA (max)
$\Delta V_R/\Delta T$	Average Reverse Breakdown Voltage Temperature Coefficient (3)	$I_R = 10 \text{ mA}$	± 20			ppm/ $^\circ\text{C}$
		$I_R = 1 \text{ mA}$	± 15	± 100	± 100	ppm/ $^\circ\text{C}$ (max)
		$I_R = 100 \mu\text{A}$	± 15			ppm/ $^\circ\text{C}$
$\Delta V_R/\Delta I_R$	Reverse Breakdown Voltage Change with Operating Current Change (4)	$I_{RMIN} \leq I_R \leq 1 \text{ mA}$	0.3			mV
				0.8	0.8	mV (max)
		$1 \text{ mA} \leq I_R \leq 15 \text{ mA}$		1.0	1.0	mV (max)
			2.5			mV
				6.0	6.0	mV (max)
		8.0	8.0	mV (max)		
Z_R	Reverse Dynamic Impedance	$I_R = 1 \text{ mA}$, $f = 120 \text{ Hz}$, $I_{AC} = 0.1 I_R$	0.3			Ω
				0.8	0.8	Ω (max)
e_N	Wideband Noise	$I_R = 100 \mu\text{A}$ $10 \text{ Hz} \leq f \leq 10 \text{ kHz}$	35			μV_{rms}

(1) Typicals are at $T_J = 25^\circ\text{C}$ and represent most likely parametric norm.

(2) Limits are 100% production tested at 25°C . Limits over temperature are guaranteed through correlation using Statistical Quality Control (SQC) methods. The limits are used to calculate National's AOQL.

(3) The boldface (over-temperature) limit for Reverse Breakdown Voltage Tolerance is defined as the room temperature Reverse Breakdown Voltage Tolerance $\pm[(\Delta V_R/\Delta T)(\max\Delta T)(V_R)]$. Where, $\Delta V_R/\Delta T$ is the V_R temperature coefficient, $\max\Delta T$ is the maximum difference in temperature from the reference point of 25°C to T_{MIN} or T_{MAX} , and V_R is the reverse breakdown voltage. The total over-temperature tolerance for the different grades in the industrial temperature range where $\max\Delta T = 65^\circ\text{C}$ is shown below:

$$\text{A-grade: } \pm 0.75\% = \pm 0.1\% \pm 100 \text{ ppm}/^\circ\text{C} \times 65^\circ\text{C}$$

$$\text{B-grade: } \pm 0.85\% = \pm 0.2\% \pm 100 \text{ ppm}/^\circ\text{C} \times 65^\circ\text{C}$$

$$\text{C-grade: } \pm 1.15\% = \pm 0.5\% \pm 100 \text{ ppm}/^\circ\text{C} \times 65^\circ\text{C}$$

$$\text{D-grade: } \pm 1.98\% = \pm 1.0\% \pm 150 \text{ ppm}/^\circ\text{C} \times 65^\circ\text{C}$$

$$\text{E-grade: } \pm 2.98\% = \pm 2.0\% \pm 150 \text{ ppm}/^\circ\text{C} \times 65^\circ\text{C}$$

The total over-temperature tolerance for the different grades in the extended temperature range where $\max\Delta T = 100^\circ\text{C}$ is shown below:

$$\text{C-grade: } \pm 1.5\% = \pm 0.5\% \pm 100 \text{ ppm}/^\circ\text{C} \times 100^\circ\text{C}$$

$$\text{D-grade: } \pm 2.5\% = \pm 1.0\% \pm 150 \text{ ppm}/^\circ\text{C} \times 100^\circ\text{C}$$

$$\text{E-grade: } \pm 3.5\% = \pm 2.0\% \pm 150 \text{ ppm}/^\circ\text{C} \times 100^\circ\text{C}$$

, as an example, the A-grade LM4040-2.5 has an over-temperature Reverse Breakdown Voltage tolerance of $\pm 2.5\text{V} \times 0.75\% = \pm 19 \text{ mV}$.

(4) Load regulation is measured on pulse basis from no load to the specified load current. Output changes due to die temperature change must be taken into account separately.

LM4040-2.5 Electrical Characteristics

V_R Tolerance Grades 'A' and 'B'; Temperature Grade 'I' (AEC Grade 3) (continued)

Boldface limits apply for $T_A = T_J = T_{MIN}$ to T_{MAX} ; all other limits $T_A = T_J = 25^\circ\text{C}$. The grades A and B designate initial Reverse Breakdown Voltage tolerances of $\pm 0.1\%$ and $\pm 0.2\%$, respectively.

Symbol	Parameter	Conditions	Typical (1)	LM4040AIM3	LM4040BIM3	Units
				LM4040AIZ	LM4040BIZ	
				—	LM4040BIM7	
				LM4040QAIM3	LM4040QBIM3	
				Limits (2)	Limits (2)	
ΔV_R	Reverse Breakdown Voltage Long Term Stability	t = 1000 hrs T = $25^\circ\text{C} \pm 0.1^\circ\text{C}$ $I_R = 100 \mu\text{A}$	120			ppm
V_{HYST}	Thermal Hysteresis (5)	$\Delta T = -40^\circ\text{C}$ to $+125^\circ\text{C}$	0.08			%

(5) Thermal hysteresis is defined as the difference in voltage measured at $+25^\circ\text{C}$ after cycling to temperature -40°C and the 25°C measurement after cycling to temperature $+125^\circ\text{C}$.

LM4040-2.5 Electrical Characteristics
 V_R Tolerance Grades 'C', 'D', and 'E'; Temperature Grade 'I' (AEC Grade 3)

Boldface limits apply for $T_A = T_J = T_{MIN}$ to T_{MAX} ; all other limits $T_A = T_J = 25^\circ\text{C}$. The grades C, D and E designate initial Reverse Breakdown Voltage tolerances of $\pm 0.5\%$, $\pm 1.0\%$ and $\pm 2.0\%$, respectively.

Symbol	Parameter	Conditions	Typical (1)	LM4040CIZ	LM4040DIZ	LM4040EIZ	Units
				LM4040CIM3	LM4040DIM3	LM4040EIM3	
				LM4040CIM7	LM4040DIM7	LM4040EIM7	
				LM4040QCIM3	LM4040QDIM3	LM4040QEIM3	
				Limits (2)	Limits (2)	Limits (2)	
V_R	Reverse Breakdown Voltage	$I_R = 100 \mu\text{A}$	2.500				V
	Reverse Breakdown Voltage Tolerance (3)	$I_R = 100 \mu\text{A}$		± 12	± 25	± 50	mV (max)
I_{RMIN}	Minimum Operating Current		45				μA
				60	65	65	μA (max)
				65	70	70	μA (max)
$\Delta V_R/\Delta T$	Average Reverse Breakdown Voltage Temperature Coefficient (3)	$I_R = 10 \text{ mA}$	± 20				ppm/ $^\circ\text{C}$
		$I_R = 1 \text{ mA}$	± 15	± 100	± 150	± 150	ppm/ $^\circ\text{C}$ (max)
		$I_R = 100 \mu\text{A}$	± 15				ppm/ $^\circ\text{C}$
$\Delta V_R/\Delta I_R$	Reverse Breakdown Voltage Change with Operating Current Change (4)	$I_{RMIN} \leq I_R \leq 1 \text{ mA}$	0.3				mV
				0.8	1.0	1.0	mV (max)
				1.0	1.2	1.2	mV (max)
		$1 \text{ mA} \leq I_R \leq 15 \text{ mA}$	2.5				mV
				6.0	8.0	8.0	mV (max)
				8.0	10.0	10.0	mV (max)
Z_R	Reverse Dynamic Impedance	$I_R = 1 \text{ mA}, f = 120 \text{ Hz}$ $I_{AC} = 0.1 I_R$	0.3				Ω
				0.9	1.1	1.1	Ω (max)
e_N	Wideband Noise	$I_R = 100 \mu\text{A}$ $10 \text{ Hz} \leq f \leq 10 \text{ kHz}$	35				μV_{rms}

(1) Typicals are at $T_J = 25^\circ\text{C}$ and represent most likely parametric norm.

(2) Limits are 100% production tested at 25°C . Limits over temperature are guaranteed through correlation using Statistical Quality Control (SQC) methods. The limits are used to calculate National's AOQL.

(3) The boldface (over-temperature) limit for Reverse Breakdown Voltage Tolerance is defined as the room temperature Reverse Breakdown Voltage Tolerance $\pm[(\Delta V_R/\Delta T)(\max\Delta T)(V_R)]$. Where, $\Delta V_R/\Delta T$ is the V_R temperature coefficient, $\max\Delta T$ is the maximum difference in temperature from the reference point of 25°C to T_{MIN} or T_{MAX} , and V_R is the reverse breakdown voltage. The total over-temperature tolerance for the different grades in the industrial temperature range where $\max\Delta T = 65^\circ\text{C}$ is shown below:

$$\text{A-grade: } \pm 0.75\% = \pm 0.1\% \pm 100 \text{ ppm}/^\circ\text{C} \times 65^\circ\text{C}$$

$$\text{B-grade: } \pm 0.85\% = \pm 0.2\% \pm 100 \text{ ppm}/^\circ\text{C} \times 65^\circ\text{C}$$

$$\text{C-grade: } \pm 1.15\% = \pm 0.5\% \pm 100 \text{ ppm}/^\circ\text{C} \times 65^\circ\text{C}$$

$$\text{D-grade: } \pm 1.98\% = \pm 1.0\% \pm 150 \text{ ppm}/^\circ\text{C} \times 65^\circ\text{C}$$

$$\text{E-grade: } \pm 2.98\% = \pm 2.0\% \pm 150 \text{ ppm}/^\circ\text{C} \times 65^\circ\text{C}$$

The total over-temperature tolerance for the different grades in the extended temperature range where $\max\Delta T = 100^\circ\text{C}$ is shown below:

$$\text{C-grade: } \pm 1.5\% = \pm 0.5\% \pm 100 \text{ ppm}/^\circ\text{C} \times 100^\circ\text{C}$$

$$\text{D-grade: } \pm 2.5\% = \pm 1.0\% \pm 150 \text{ ppm}/^\circ\text{C} \times 100^\circ\text{C}$$

$$\text{E-grade: } \pm 3.5\% = \pm 2.0\% \pm 150 \text{ ppm}/^\circ\text{C} \times 100^\circ\text{C}$$

, as an example, the A-grade LM4040-2.5 has an over-temperature Reverse Breakdown Voltage tolerance of $\pm 2.5\text{V} \times 0.75\% = \pm 19 \text{ mV}$.

(4) Load regulation is measured on pulse basis from no load to the specified load current. Output changes due to die temperature change must be taken into account separately.

LM4040-2.5 Electrical Characteristics **V_R Tolerance Grades 'C', 'D', and 'E'; Temperature Grade 'I' (AEC Grade 3) (continued)**

Boldface limits apply for $T_A = T_J = T_{MIN}$ to T_{MAX} ; all other limits $T_A = T_J = 25^\circ\text{C}$. The grades C, D and E designate initial Reverse Breakdown Voltage tolerances of $\pm 0.5\%$, $\pm 1.0\%$ and $\pm 2.0\%$, respectively.

Symbol	Parameter	Conditions	Typical (1)	LM4040CIZ	LM4040DIZ	LM4040EIZ	Units
				LM4040CIM3	LM4040DIM3	LM4040EIM3	
				LM4040CIM7	LM4040DIM7	LM4040EIM7	
				LM4040QCIM3	LM4040QDIM3	LM4040QEIM3	
				Limits (2)	Limits (2)	Limits (2)	
ΔV_R	Reverse Breakdown Voltage Long Term Stability	t = 1000 hrs T = 25°C $\pm 0.1^\circ\text{C}$ $I_R = 100 \mu\text{A}$	120				ppm
V_{HYST}	Thermal Hysteresis (5)	$\Delta T = -40^\circ\text{C}$ to $+125^\circ\text{C}$	0.08				%

(5) Thermal hysteresis is defined as the difference in voltage measured at $+25^\circ\text{C}$ after cycling to temperature -40°C and the 25°C measurement after cycling to temperature $+125^\circ\text{C}$.

LM4040-2.5 Electrical Characteristics
V_R Tolerance Grades 'C', 'D', and 'E'; Temperature Grade 'E' (AEC Grade 1)

Boldface limits apply for T_A = T_J = T_{MIN} to T_{MAX}; all other limits T_A = T_J = 25°C. The grades C, D and E designate initial Reverse Breakdown Voltage tolerances of ±0.5%, ±1.0% and ±2.0%, respectively.

Symbol	Parameter	Conditions	Typical (1)	LM4040CEM3	LM4040DEM3	LM4040EEM3	Units
				LM4040QCEM3	LM4040QDEM3	LM4040QEEM3	
				Limits (2)	Limits (2)	Limits (2)	
V _R	Reverse Breakdown Voltage	I _R = 100 μA	2.500				V
	Reverse Breakdown Voltage Tolerance ⁽³⁾	I _R = 100 μA		±12	±25	±50	mV (max)
				±38	±63	±88	mV (max)
I _{RMIN}	Minimum Operating Current		45				μA
				60	65	65	μA (max)
				68	73	73	μA (max)
ΔV _R /ΔT	Average Reverse Breakdown Voltage Temperature Coefficient ⁽³⁾	I _R = 10 mA	±20				ppm/°C
		I _R = 1 mA	±15	±100	±150	±150	ppm/°C (max)
		I _R = 100 μA	±15				ppm/°C
ΔV _R /ΔI _R	Reverse Breakdown Voltage Change with Operating Current Change ⁽⁴⁾	I _{RMIN} ≤ I _R ≤ 1 mA	0.3				mV
				0.8	1.0	1.0	mV (max)
				1.0	1.2	1.2	mV (max)
		1 mA ≤ I _R ≤ 15 mA	2.5				mV
				6.0	8.0	8.0	mV (max)
		8.0	10.0	10.0	mV (max)		
Z _R	Reverse Dynamic Impedance	I _R = 1 mA, f = 120 Hz, I _{AC} = 0.1 I _R	0.3				Ω
				0.9	1.1	1.1	Ω (max)
e _N	Wideband Noise	I _R = 100 μA 10 Hz ≤ f ≤ 10 kHz	35				μV _{rms}
ΔV _R	Reverse Breakdown Voltage Long Term Stability	t = 1000 hrs T = 25°C ±0.1°C I _R = 100 μA	120				ppm

(1) Typicals are at T_J = 25°C and represent most likely parametric norm.

(2) Limits are 100% production tested at 25°C. Limits over temperature are guaranteed through correlation using Statistical Quality Control (SQC) methods. The limits are used to calculate National's AOQL.

(3) The boldface (over-temperature) limit for Reverse Breakdown Voltage Tolerance is defined as the room temperature Reverse Breakdown Voltage Tolerance ±[(ΔV_R/ΔT)(maxΔT)(V_R)]. Where, ΔV_R/ΔT is the V_R temperature coefficient, maxΔT is the maximum difference in temperature from the reference point of 25°C to T_{MIN} or T_{MAX}, and V_R is the reverse breakdown voltage. The total over-temperature tolerance for the different grades in the industrial temperature range where maxΔT = 65°C is shown below:

$$\text{A-grade: } \pm 0.75\% = \pm 0.1\% \pm 100 \text{ ppm/}^\circ\text{C} \times 65^\circ\text{C}$$

$$\text{B-grade: } \pm 0.85\% = \pm 0.2\% \pm 100 \text{ ppm/}^\circ\text{C} \times 65^\circ\text{C}$$

$$\text{C-grade: } \pm 1.15\% = \pm 0.5\% \pm 100 \text{ ppm/}^\circ\text{C} \times 65^\circ\text{C}$$

$$\text{D-grade: } \pm 1.98\% = \pm 1.0\% \pm 150 \text{ ppm/}^\circ\text{C} \times 65^\circ\text{C}$$

$$\text{E-grade: } \pm 2.98\% = \pm 2.0\% \pm 150 \text{ ppm/}^\circ\text{C} \times 65^\circ\text{C}$$

The total over-temperature tolerance for the different grades in the extended temperature range where max ΔT = 100 °C is shown below:

$$\text{C-grade: } \pm 1.5\% = \pm 0.5\% \pm 100 \text{ ppm/}^\circ\text{C} \times 100^\circ\text{C}$$

$$\text{D-grade: } \pm 2.5\% = \pm 1.0\% \pm 150 \text{ ppm/}^\circ\text{C} \times 100^\circ\text{C}$$

$$\text{E-grade: } \pm 3.5\% = \pm 2.0\% \pm 150 \text{ ppm/}^\circ\text{C} \times 100^\circ\text{C}$$

, as an example, the A-grade LM4040-2.5 has an over-temperature Reverse Breakdown Voltage tolerance of ±2.5V × 0.75% = ±19 mV.

(4) Load regulation is measured on pulse basis from no load to the specified load current. Output changes due to die temperature change must be taken into account separately.

LM4040-2.5 Electrical Characteristics**V_R Tolerance Grades 'C', 'D', and 'E'; Temperature Grade 'E' (AEC Grade 1) (continued)**

Boldface limits apply for T_A = T_J = T_{MIN} to T_{MAX}; all other limits T_A = T_J = 25°C. The grades C, D and E designate initial Reverse Breakdown Voltage tolerances of ±0.5%, ±1.0% and ±2.0%, respectively.

Symbol	Parameter	Conditions	Typical (1)	LM4040CEM3	LM4040DEM3	LM4040EEM3	Units
				LM4040QCEM3	LM4040QDEM3	LM4040QEEM3	
				Limits (2)	Limits (2)	Limits (2)	
V _{HYST}	Thermal Hysteresis (5)	ΔT= -40°C to +125°C	0.08				%

(5) Thermal hysteresis is defined as the difference in voltage measured at +25°C after cycling to temperature -40°C and the 25°C measurement after cycling to temperature +125°C.

LM4040-3.0 Electrical Characteristics

V_R Tolerance Grades 'A' and 'B'; Temperature Grade 'I'

Boldface limits apply for $T_A = T_J = T_{MIN}$ to T_{MAX} ; all other limits $T_A = T_J = 25^\circ\text{C}$. The grades A and B designate initial Reverse Breakdown Voltage tolerances of $\pm 0.1\%$ and $\pm 0.2\%$, respectively.

Symbol	Parameter	Conditions	Typical (1)	LM4040AIM3 LM4040AIZ — Limits (2)	LM4040BIM3 LM4040BIZ LM4040BIM7 Limits (2)	Units
V_R	Reverse Breakdown Voltage	$I_R = 100 \mu\text{A}$	3.000			V
	Reverse Breakdown Voltage Tolerance (3)	$I_R = 100 \mu\text{A}$		± 3.0	± 6.0	mV (max)
I_{RMIN}	Minimum Operating Current		47			μA
				62	62	μA (max)
				67	67	μA (max)
$\Delta V_R/\Delta T$	Average Reverse Breakdown Voltage Temperature Coefficient (3)	$I_R = 10 \text{ mA}$	± 20			ppm/ $^\circ\text{C}$
		$I_R = 1 \text{ mA}$	± 15	± 100	± 100	ppm/ $^\circ\text{C}$ (max)
		$I_R = 100 \mu\text{A}$	± 15			ppm/ $^\circ\text{C}$
$\Delta V_R/\Delta I_R$	Reverse Breakdown Voltage Change with Operating Current Change (4)	$I_{RMIN} \leq I_R \leq 1 \text{ mA}$	0.6			mV
				0.8	0.8	mV (max)
				1.1	1.1	mV (max)
		$1 \text{ mA} \leq I_R \leq 15 \text{ mA}$	2.7			mV
				6.0	6.0	mV (max)
		9.0	9.0	mV (max)		
Z_R	Reverse Dynamic Impedance	$I_R = 1 \text{ mA}$, $f = 120 \text{ Hz}$, $I_{AC} = 0.1 I_R$	0.4			Ω
				0.9	0.9	Ω (max)
e_N	Wideband Noise	$I_R = 100 \mu\text{A}$ $10 \text{ Hz} \leq f \leq 10 \text{ kHz}$	35			μV_{rms}
ΔV_R	Reverse Breakdown Voltage Long Term Stability	$t = 1000 \text{ hrs}$ $T = 25^\circ\text{C} \pm 0.1^\circ\text{C}$ $I_R = 100 \mu\text{A}$	120			ppm

(1) Typicals are at $T_J = 25^\circ\text{C}$ and represent most likely parametric norm.

(2) Limits are 100% production tested at 25°C . Limits over temperature are guaranteed through correlation using Statistical Quality Control (SQC) methods. The limits are used to calculate National's AOQL.

(3) The boldface (over-temperature) limit for Reverse Breakdown Voltage Tolerance is defined as the room temperature Reverse Breakdown Voltage Tolerance $\pm[(\Delta V_R/\Delta T)(\max\Delta T)(V_R)]$. Where, $\Delta V_R/\Delta T$ is the V_R temperature coefficient, $\max\Delta T$ is the maximum difference in temperature from the reference point of 25°C to T_{MIN} or T_{MAX} , and V_R is the reverse breakdown voltage. The total over-temperature tolerance for the different grades in the industrial temperature range where $\max\Delta T = 65^\circ\text{C}$ is shown below:

$$\text{A-grade: } \pm 0.75\% = \pm 0.1\% \pm 100 \text{ ppm}/^\circ\text{C} \times 65^\circ\text{C}$$

$$\text{B-grade: } \pm 0.85\% = \pm 0.2\% \pm 100 \text{ ppm}/^\circ\text{C} \times 65^\circ\text{C}$$

$$\text{C-grade: } \pm 1.15\% = \pm 0.5\% \pm 100 \text{ ppm}/^\circ\text{C} \times 65^\circ\text{C}$$

$$\text{D-grade: } \pm 1.98\% = \pm 1.0\% \pm 150 \text{ ppm}/^\circ\text{C} \times 65^\circ\text{C}$$

$$\text{E-grade: } \pm 2.98\% = \pm 2.0\% \pm 150 \text{ ppm}/^\circ\text{C} \times 65^\circ\text{C}$$

The total over-temperature tolerance for the different grades in the extended temperature range where $\max\Delta T = 100^\circ\text{C}$ is shown below:

$$\text{C-grade: } \pm 1.5\% = \pm 0.5\% \pm 100 \text{ ppm}/^\circ\text{C} \times 100^\circ\text{C}$$

$$\text{D-grade: } \pm 2.5\% = \pm 1.0\% \pm 150 \text{ ppm}/^\circ\text{C} \times 100^\circ\text{C}$$

$$\text{E-grade: } \pm 3.5\% = \pm 2.0\% \pm 150 \text{ ppm}/^\circ\text{C} \times 100^\circ\text{C}$$

, as an example, the A-grade LM4040-2.5 has an over-temperature Reverse Breakdown Voltage tolerance of $\pm 2.5\% \times 0.75\% = \pm 19 \text{ mV}$.

(4) Load regulation is measured on pulse basis from no load to the specified load current. Output changes due to die temperature change must be taken into account separately.

LM4040-3.0 Electrical Characteristics

V_R Tolerance Grades 'A' and 'B'; Temperature Grade 'I' (continued)

Boldface limits apply for $T_A = T_J = T_{MIN}$ to T_{MAX} ; all other limits $T_A = T_J = 25^\circ\text{C}$. The grades A and B designate initial Reverse Breakdown Voltage tolerances of $\pm 0.1\%$ and $\pm 0.2\%$, respectively.

Symbol	Parameter	Conditions	Typical (1)	LM4040AIM3 LM4040AIZ — Limits (2)	LM4040BIM3 LM4040BIZ LM4040BIM7 Limits (2)	Units
V_{HYST}	Thermal Hysteresis (5)	$\Delta T = -40^\circ\text{C}$ to $+125^\circ\text{C}$	0.08			%

- (5) Thermal hysteresis is defined as the difference in voltage measured at $+25^\circ\text{C}$ after cycling to temperature -40°C and the 25°C measurement after cycling to temperature $+125^\circ\text{C}$.

LM4040-3.0 Electrical Characteristics

V_R Tolerance Grades 'C', 'D', and 'E'; Temperature Grade 'I'

Boldface limits apply for $T_A = T_J = T_{MIN}$ to T_{MAX} ; all other limits $T_A = T_J = 25^\circ\text{C}$. The grades C, D and E designate initial Reverse Breakdown Voltage tolerances of $\pm 0.5\%$, $\pm 1.0\%$ and $\pm 2.0\%$, respectively.

Symbol	Parameter	Conditions	Typical (1)	LM4040CIM3 LM4040CIZ LM4040CIM7 Limits (2)	LM4040DIM3 LM4040DIZ LM4040DIM7 Limits (2)	LM4040EIM7 LM4040EIZ — Limits (2)	Units
V_R	Reverse Breakdown Voltage	$I_R = 100 \mu\text{A}$	3.000				V
	Reverse Breakdown Voltage Tolerance (3)	$I_R = 100 \mu\text{A}$		± 15	± 30	± 60	mV (max)
I_{RMIN}	Minimum Operating Current		45				μA
			60	65	65	μA (max)	
			65	70	70	μA (max)	
$\Delta V_R/\Delta T$	Average Reverse Breakdown Voltage Temperature Coefficient (3)	$I_R = 10 \text{ mA}$	± 20				ppm/ $^\circ\text{C}$
		$I_R = 1 \text{ mA}$	± 15	± 100	± 150	± 150	ppm/ $^\circ\text{C}$ (max)
		$I_R = 100 \mu\text{A}$	± 15				ppm/ $^\circ\text{C}$
$\Delta V_R/\Delta I_R$	Reverse Breakdown Voltage Change with Operating Current Change (4)	$I_{RMIN} \leq I_R \leq 1 \text{ mA}$	0.4				mV
			0.8	1.1	1.1	mV (max)	
			1.1	1.3	1.3	mV (max)	
		$1 \text{ mA} \leq I_R \leq 15 \text{ mA}$	2.7				mV
			6.0	8.0	8.0	mV (max)	
	9.0	11.0	11.0	mV (max)			
Z_R	Reverse Dynamic Impedance	$I_R = 1 \text{ mA}$, $f = 120 \text{ Hz}$ $I_{AC} = 0.1 I_R$	0.4				Ω
			0.9	1.2	1.2	Ω (max)	
e_N	Wideband Noise	$I_R = 100 \mu\text{A}$ $10 \text{ Hz} \leq f \leq 10 \text{ kHz}$	35				μV_{rms}

(1) Typicals are at $T_J = 25^\circ\text{C}$ and represent most likely parametric norm.

(2) Limits are 100% production tested at 25°C . Limits over temperature are guaranteed through correlation using Statistical Quality Control (SQC) methods. The limits are used to calculate National's AOQL.

(3) The boldface (over-temperature) limit for Reverse Breakdown Voltage Tolerance is defined as the room temperature Reverse Breakdown Voltage Tolerance $\pm[(\Delta V_R/\Delta T)(\text{max}\Delta T)(V_R)]$. Where, $\Delta V_R/\Delta T$ is the V_R temperature coefficient, $\text{max}\Delta T$ is the maximum difference in temperature from the reference point of 25°C to T_{MIN} or T_{MAX} , and V_R is the reverse breakdown voltage. The total over-temperature tolerance for the different grades in the industrial temperature range where $\text{max}\Delta T = 65^\circ\text{C}$ is shown below:

$$\text{A-grade: } \pm 0.75\% = \pm 0.1\% \pm 100 \text{ ppm}/^\circ\text{C} \times 65^\circ\text{C}$$

$$\text{B-grade: } \pm 0.85\% = \pm 0.2\% \pm 100 \text{ ppm}/^\circ\text{C} \times 65^\circ\text{C}$$

$$\text{C-grade: } \pm 1.15\% = \pm 0.5\% \pm 100 \text{ ppm}/^\circ\text{C} \times 65^\circ\text{C}$$

$$\text{D-grade: } \pm 1.98\% = \pm 1.0\% \pm 150 \text{ ppm}/^\circ\text{C} \times 65^\circ\text{C}$$

$$\text{E-grade: } \pm 2.98\% = \pm 2.0\% \pm 150 \text{ ppm}/^\circ\text{C} \times 65^\circ\text{C}$$

The total over-temperature tolerance for the different grades in the extended temperature range where $\text{max}\Delta T = 100^\circ\text{C}$ is shown below:

$$\text{C-grade: } \pm 1.5\% = \pm 0.5\% \pm 100 \text{ ppm}/^\circ\text{C} \times 100^\circ\text{C}$$

$$\text{D-grade: } \pm 2.5\% = \pm 1.0\% \pm 150 \text{ ppm}/^\circ\text{C} \times 100^\circ\text{C}$$

$$\text{E-grade: } \pm 3.5\% = \pm 2.0\% \pm 150 \text{ ppm}/^\circ\text{C} \times 100^\circ\text{C}$$

, as an example, the A-grade LM4040-2.5 has an over-temperature Reverse Breakdown Voltage tolerance of $\pm 2.5\% \times 0.75\% = \pm 19 \text{ mV}$.

(4) Load regulation is measured on pulse basis from no load to the specified load current. Output changes due to die temperature change must be taken into account separately.

LM4040-3.0 Electrical Characteristics

V_R Tolerance Grades 'C', 'D', and 'E'; Temperature Grade 'I' (continued)

Boldface limits apply for $T_A = T_J = T_{MIN}$ to T_{MAX} ; all other limits $T_A = T_J = 25^\circ\text{C}$. The grades C, D and E designate initial Reverse Breakdown Voltage tolerances of $\pm 0.5\%$, $\pm 1.0\%$ and $\pm 2.0\%$, respectively.

Symbol	Parameter	Conditions	Typical (1)	LM4040CIM3 LM4040CIZ LM4040CIM7 Limits (2)	LM4040DIM3 LM4040DIZ LM4040DIM7 Limits (2)	LM4040EIM7 LM4040EIZ — Limits (2)	Units
ΔV_R	Reverse Breakdown Voltage Long Term Stability	t = 1000 hrs T = $25^\circ\text{C} \pm 0.1^\circ\text{C}$ $I_R = 100 \mu\text{A}$	120				ppm
V_{HYST}	Thermal Hysteresis (5)	$\Delta T = -40^\circ\text{C}$ to $+125^\circ\text{C}$	0.08				%

(5) Thermal hysteresis is defined as the difference in voltage measured at $+25^\circ\text{C}$ after cycling to temperature -40°C and the 25°C measurement after cycling to temperature $+125^\circ\text{C}$.

LM4040-3.0 Electrical Characteristics

V_R Tolerance Grades 'C', 'D', and 'E'; Temperature Grade 'E'

Boldface limits apply for $T_A = T_J = T_{MIN}$ to T_{MAX} ; all other limits $T_A = T_J = 25^\circ\text{C}$. The grades C, D and E designate initial Reverse Breakdown Voltage tolerances of $\pm 0.5\%$, $\pm 1.0\%$ and $\pm 2.0\%$, respectively.

Symbol	Parameter	Conditions	Typical (1)	LM4040CEM3 Limits (2)	LM4040DEM3 Limits (2)	LM4040EEM3 Limits (2)	Units
V_R	Reverse Breakdown Voltage	$I_R = 100 \mu\text{A}$	3.000				V
	Reverse Breakdown Voltage Tolerance (3)	$I_R = 100 \mu\text{A}$		± 15 ± 45	± 30 ± 75	± 60 ± 105	mV (max) mV (max)
I_{RMIN}	Minimum Operating Current		47				μA
				62	67	67	μA (max)
				70	75	75	μA (max)
$\Delta V_R/\Delta T$	Average Reverse Breakdown Voltage Temperature Coefficient (3)	$I_R = 10 \text{ mA}$	± 20				ppm/ $^\circ\text{C}$
		$I_R = 1 \text{ mA}$	± 15	± 100	± 150	± 150	ppm/ $^\circ\text{C}$ (max)
		$I_R = 100 \mu\text{A}$	± 15				ppm/ $^\circ\text{C}$
$\Delta V_R/\Delta I_R$	Reverse Breakdown Voltage Change with Operating Current Change (4)	$I_{RMIN} \leq I_R \leq 1 \text{ mA}$	0.4				mV
			0.8	1.1	1.1	mV (max)	
		$1 \text{ mA} \leq I_R \leq 15 \text{ mA}$	1.1	1.3	1.3	mV (max)	
			2.7			mV	
			9.0	11.0	11.0	mV (max)	
Z_R	Reverse Dynamic Impedance	$I_R = 1 \text{ mA}$, $f = 120 \text{ Hz}$, $I_{AC} = 0.1 I_R$	0.4				Ω
			0.9	1.2	1.2	Ω (max)	
e_N	Wideband Noise	$I_R = 100 \mu\text{A}$ $10 \text{ Hz} \leq f \leq 10 \text{ kHz}$	35				μV_{rms}
ΔV_R	Reverse Breakdown Voltage Long Term Stability	$t = 1000 \text{ hrs}$ $T = 25^\circ\text{C} \pm 0.1^\circ\text{C}$ $I_R = 100 \mu\text{A}$	120				ppm

(1) Typicals are at $T_J = 25^\circ\text{C}$ and represent most likely parametric norm.

(2) Limits are 100% production tested at 25°C . Limits over temperature are guaranteed through correlation using Statistical Quality Control (SQC) methods. The limits are used to calculate National's AOQL.

(3) The boldface (over-temperature) limit for Reverse Breakdown Voltage Tolerance is defined as the room temperature Reverse Breakdown Voltage Tolerance $\pm[(\Delta V_R/\Delta T)(\max\Delta T)(V_R)]$. Where, $\Delta V_R/\Delta T$ is the V_R temperature coefficient, $\max\Delta T$ is the maximum difference in temperature from the reference point of 25°C to T_{MIN} or T_{MAX} , and V_R is the reverse breakdown voltage. The total over-temperature tolerance for the different grades in the industrial temperature range where $\max\Delta T = 65^\circ\text{C}$ is shown below:

$$\text{A-grade: } \pm 0.75\% = \pm 0.1\% \pm 100 \text{ ppm}/^\circ\text{C} \times 65^\circ\text{C}$$

$$\text{B-grade: } \pm 0.85\% = \pm 0.2\% \pm 100 \text{ ppm}/^\circ\text{C} \times 65^\circ\text{C}$$

$$\text{C-grade: } \pm 1.15\% = \pm 0.5\% \pm 100 \text{ ppm}/^\circ\text{C} \times 65^\circ\text{C}$$

$$\text{D-grade: } \pm 1.98\% = \pm 1.0\% \pm 150 \text{ ppm}/^\circ\text{C} \times 65^\circ\text{C}$$

$$\text{E-grade: } \pm 2.98\% = \pm 2.0\% \pm 150 \text{ ppm}/^\circ\text{C} \times 65^\circ\text{C}$$

The total over-temperature tolerance for the different grades in the extended temperature range where $\max\Delta T = 100^\circ\text{C}$ is shown below:

$$\text{C-grade: } \pm 1.5\% = \pm 0.5\% \pm 100 \text{ ppm}/^\circ\text{C} \times 100^\circ\text{C}$$

$$\text{D-grade: } \pm 2.5\% = \pm 1.0\% \pm 150 \text{ ppm}/^\circ\text{C} \times 100^\circ\text{C}$$

$$\text{E-grade: } \pm 3.5\% = \pm 2.0\% \pm 150 \text{ ppm}/^\circ\text{C} \times 100^\circ\text{C}$$

, as an example, the A-grade LM4040-2.5 has an over-temperature Reverse Breakdown Voltage tolerance of $\pm 2.5\% \times 0.75\% = \pm 19 \text{ mV}$.

(4) Load regulation is measured on pulse basis from no load to the specified load current. Output changes due to die temperature change must be taken into account separately.

LM4040-3.0 Electrical Characteristics**V_R Tolerance Grades 'C', 'D', and 'E'; Temperature Grade 'E' (continued)**

Boldface limits apply for T_A = T_J = T_{MIN} to T_{MAX}; all other limits T_A = T_J = 25°C. The grades C, D and E designate initial Reverse Breakdown Voltage tolerances of ±0.5%, ±1.0% and ±2.0%, respectively.

Symbol	Parameter	Conditions	Typical (1)	LM4040CEM3 Limits (2)	LM4040DEM3 Limits (2)	LM4040EEM3 Limits (2)	Units
V _{HYST}	Thermal Hysteresis (5)	ΔT = -40°C to +125°C	0.08				%

(5) Thermal hysteresis is defined as the difference in voltage measured at +25°C after cycling to temperature -40°C and the 25°C measurement after cycling to temperature +125°C.

LM4040-4.1 Electrical Characteristics

V_R Tolerance Grades 'A' and 'B'; Temperature Grade 'I'

Boldface limits apply for $T_A = T_J = T_{MIN}$ to T_{MAX} ; all other limits $T_A = T_J = 25^\circ\text{C}$. The grades A and B designate initial Reverse Breakdown Voltage tolerances of $\pm 0.1\%$ and $\pm 0.2\%$, respectively.

Symbol	Parameter	Conditions	Typical (1)	LM4040AIM3 LM4040AIZ — Limits (2)	LM4040BIM3 LM4040BIZ LM4040BIM7 Limits (2)	Units
V_R	Reverse Breakdown Voltage	$I_R = 100 \mu\text{A}$	4.096			V
	Reverse Breakdown Voltage Tolerance (3)	$I_R = 100 \mu\text{A}$		± 4.1 ± 31	± 8.2 ± 35	mV (max) mV (max)
I_{RMIN}	Minimum Operating Current		50			μA
				68	68	μA (max)
				73	73	μA (max)
$\Delta V_R/\Delta T$	Average Reverse Breakdown Voltage Temperature Coefficient (3)	$I_R = 10 \text{ mA}$	± 30			ppm/ $^\circ\text{C}$
		$I_R = 1 \text{ mA}$	± 20	± 100	± 100	ppm/ $^\circ\text{C}$ (max)
		$I_R = 100 \mu\text{A}$	± 20			ppm/ $^\circ\text{C}$
$\Delta V_R/\Delta I_R$	Reverse Breakdown Voltage Change with Operating Current Change (4)	$I_{RMIN} \leq I_R \leq 1 \text{ mA}$	0.5			mV
				0.9	0.9	mV (max)
				1.2	1.2	mV (max)
		$1 \text{ mA} \leq I_R \leq 15 \text{ mA}$	3.0			mV
				7.0	7.0	mV (max)
		10.0	10.0	mV (max)		
Z_R	Reverse Dynamic Impedance	$I_R = 1 \text{ mA}$, $f = 120 \text{ Hz}$, $I_{AC} = 0.1 I_R$	0.5			Ω
				1.0	1.0	Ω (max)
e_N	Wideband Noise	$I_R = 100 \mu\text{A}$ $10 \text{ Hz} \leq f \leq 10 \text{ kHz}$	80			μV_{rms}
ΔV_R	Reverse Breakdown Voltage Long Term Stability	$t = 1000 \text{ hrs}$ $T = 25^\circ\text{C} \pm 0.1^\circ\text{C}$ $I_R = 100 \mu\text{A}$	120			ppm

(1) Typicals are at $T_J = 25^\circ\text{C}$ and represent most likely parametric norm.

(2) Limits are 100% production tested at 25°C . Limits over temperature are guaranteed through correlation using Statistical Quality Control (SQC) methods. The limits are used to calculate National's AOQL.

(3) The boldface (over-temperature) limit for Reverse Breakdown Voltage Tolerance is defined as the room temperature Reverse Breakdown Voltage Tolerance $\pm[(\Delta V_R/\Delta T)(\max\Delta T)(V_R)]$. Where, $\Delta V_R/\Delta T$ is the V_R temperature coefficient, $\max\Delta T$ is the maximum difference in temperature from the reference point of 25°C to T_{MIN} or T_{MAX} , and V_R is the reverse breakdown voltage. The total over-temperature tolerance for the different grades in the industrial temperature range where $\max\Delta T = 65^\circ\text{C}$ is shown below:

$$\text{A-grade: } \pm 0.75\% = \pm 0.1\% \pm 100 \text{ ppm}/^\circ\text{C} \times 65^\circ\text{C}$$

$$\text{B-grade: } \pm 0.85\% = \pm 0.2\% \pm 100 \text{ ppm}/^\circ\text{C} \times 65^\circ\text{C}$$

$$\text{C-grade: } \pm 1.15\% = \pm 0.5\% \pm 100 \text{ ppm}/^\circ\text{C} \times 65^\circ\text{C}$$

$$\text{D-grade: } \pm 1.98\% = \pm 1.0\% \pm 150 \text{ ppm}/^\circ\text{C} \times 65^\circ\text{C}$$

$$\text{E-grade: } \pm 2.98\% = \pm 2.0\% \pm 150 \text{ ppm}/^\circ\text{C} \times 65^\circ\text{C}$$

The total over-temperature tolerance for the different grades in the extended temperature range where $\max\Delta T = 100^\circ\text{C}$ is shown below:

$$\text{C-grade: } \pm 1.5\% = \pm 0.5\% \pm 100 \text{ ppm}/^\circ\text{C} \times 100^\circ\text{C}$$

$$\text{D-grade: } \pm 2.5\% = \pm 1.0\% \pm 150 \text{ ppm}/^\circ\text{C} \times 100^\circ\text{C}$$

$$\text{E-grade: } \pm 3.5\% = \pm 2.0\% \pm 150 \text{ ppm}/^\circ\text{C} \times 100^\circ\text{C}$$

, as an example, the A-grade LM4040-2.5 has an over-temperature Reverse Breakdown Voltage tolerance of $\pm 2.5\% \times 0.75\% = \pm 19 \text{ mV}$.

(4) Load regulation is measured on pulse basis from no load to the specified load current. Output changes due to die temperature change must be taken into account separately.

LM4040-4.1 Electrical Characteristics

V_R Tolerance Grades 'A' and 'B'; Temperature Grade 'I' (continued)

Boldface limits apply for $T_A = T_J = T_{MIN}$ to T_{MAX} ; all other limits $T_A = T_J = 25^\circ\text{C}$. The grades A and B designate initial Reverse Breakdown Voltage tolerances of $\pm 0.1\%$ and $\pm 0.2\%$, respectively.

Symbol	Parameter	Conditions	Typical (1)	LM4040AIM3 LM4040AIZ — Limits (2)	LM4040BIM3 LM4040BIZ LM4040BIM7 Limits (2)	Units
V_{HYST}	Thermal Hysteresis (5)	$\Delta T = -40^\circ\text{C}$ to $+125^\circ\text{C}$	0.08			%

- (5) Thermal hysteresis is defined as the difference in voltage measured at $+25^\circ\text{C}$ after cycling to temperature -40°C and the 25°C measurement after cycling to temperature $+125^\circ\text{C}$.

LM4040-4.1 Electrical Characteristics

V_R Tolerance Grades 'C' and 'D'; Temperature Grade 'I'

Boldface limits apply for $T_A = T_J = T_{MIN}$ to T_{MAX} ; all other limits $T_A = T_J = 25^\circ\text{C}$. The grades C and D designate initial Reverse Breakdown Voltage tolerances of $\pm 0.5\%$ and $\pm 1.0\%$, respectively.

Symbol	Parameter	Conditions	Typical (1)	LM4040CIM3 LM4040CIZ LM4040CIM7 Limits (2)	LM4040DIM3 LM4040DIZ LM4040DIM7 Limits (2)	Units
V_R	Reverse Breakdown Voltage	$I_R = 100 \mu\text{A}$	4.096			V
	Reverse Breakdown Voltage Tolerance (3)	$I_R = 100 \mu\text{A}$		± 20 ± 47	± 41 ± 81	mV (max) mV (max)
I_{RMIN}	Minimum Operating Current		50			μA
				68	73	μA (max)
				73	78	μA (max)
$\Delta V_R/\Delta T$	Average Reverse Breakdown Voltage Temperature Coefficient (3)	$I_R = 10 \text{ mA}$	± 30			ppm/ $^\circ\text{C}$
		$I_R = 1 \text{ mA}$	± 20	± 100	± 150	ppm/ $^\circ\text{C}$ (max)
		$I_R = 100 \mu\text{A}$	± 20			ppm/ $^\circ\text{C}$
$\Delta V_R/\Delta I_R$	Reverse Breakdown Voltage Change with Operating Current Change (4)	$I_{RMIN} \leq I_R \leq 1 \text{ mA}$	0.5			mV
				0.9	1.2	mV (max)
				1.2	1.5	mV (max)
		$1 \text{ mA} \leq I_R \leq 15 \text{ mA}$	3.0			mV
				7.0	9.0	mV (max)
		10.0	13.0	mV (max)		
Z_R	Reverse Dynamic Impedance	$I_R = 1 \text{ mA}$, $f = 120 \text{ Hz}$, $I_{AC} = 0.1 I_R$	0.5			Ω
				1.0	1.3	Ω (max)
e_N	Wideband Noise	$I_R = 100 \mu\text{A}$ $10 \text{ Hz} \leq f \leq 10 \text{ kHz}$	80			μV_{rms}
ΔV_R	Reverse Breakdown Voltage Long Term Stability	$t = 1000 \text{ hrs}$ $T = 25^\circ\text{C} \pm 0.1^\circ\text{C}$ $I_R = 100 \mu\text{A}$	120			ppm

(1) Typicals are at $T_J = 25^\circ\text{C}$ and represent most likely parametric norm.

(2) Limits are 100% production tested at 25°C . Limits over temperature are guaranteed through correlation using Statistical Quality Control (SQC) methods. The limits are used to calculate National's AOQL.

(3) The boldface (over-temperature) limit for Reverse Breakdown Voltage Tolerance is defined as the room temperature Reverse Breakdown Voltage Tolerance $\pm[(\Delta V_R/\Delta T)(\max\Delta T)(V_R)]$. Where, $\Delta V_R/\Delta T$ is the V_R temperature coefficient, $\max\Delta T$ is the maximum difference in temperature from the reference point of 25°C to T_{MIN} or T_{MAX} , and V_R is the reverse breakdown voltage. The total over-temperature tolerance for the different grades in the industrial temperature range where $\max\Delta T = 65^\circ\text{C}$ is shown below:

$$\text{A-grade: } \pm 0.75\% = \pm 0.1\% \pm 100 \text{ ppm}/^\circ\text{C} \times 65^\circ\text{C}$$

$$\text{B-grade: } \pm 0.85\% = \pm 0.2\% \pm 100 \text{ ppm}/^\circ\text{C} \times 65^\circ\text{C}$$

$$\text{C-grade: } \pm 1.15\% = \pm 0.5\% \pm 100 \text{ ppm}/^\circ\text{C} \times 65^\circ\text{C}$$

$$\text{D-grade: } \pm 1.98\% = \pm 1.0\% \pm 150 \text{ ppm}/^\circ\text{C} \times 65^\circ\text{C}$$

$$\text{E-grade: } \pm 2.98\% = \pm 2.0\% \pm 150 \text{ ppm}/^\circ\text{C} \times 65^\circ\text{C}$$

The total over-temperature tolerance for the different grades in the extended temperature range where $\max\Delta T = 100^\circ\text{C}$ is shown below:

$$\text{C-grade: } \pm 1.5\% = \pm 0.5\% \pm 100 \text{ ppm}/^\circ\text{C} \times 100^\circ\text{C}$$

$$\text{D-grade: } \pm 2.5\% = \pm 1.0\% \pm 150 \text{ ppm}/^\circ\text{C} \times 100^\circ\text{C}$$

$$\text{E-grade: } \pm 3.5\% = \pm 2.0\% \pm 150 \text{ ppm}/^\circ\text{C} \times 100^\circ\text{C}$$

, as an example, the A-grade LM4040-2.5 has an over-temperature Reverse Breakdown Voltage tolerance of $\pm 2.5\text{V} \times 0.75\% = \pm 19 \text{ mV}$.

(4) Load regulation is measured on pulse basis from no load to the specified load current. Output changes due to die temperature change must be taken into account separately.

LM4040-4.1 Electrical Characteristics

V_R Tolerance Grades 'C' and 'D'; Temperature Grade 'I' (continued)

Boldface limits apply for $T_A = T_J = T_{MIN}$ to T_{MAX} ; all other limits $T_A = T_J = 25^\circ\text{C}$. The grades C and D designate initial Reverse Breakdown Voltage tolerances of $\pm 0.5\%$ and $\pm 1.0\%$, respectively.

Symbol	Parameter	Conditions	Typical (1)	LM4040CIM3 LM4040CIZ LM4040CIM7 Limits (2)	LM4040DIM3 LM4040DIZ LM4040DIM7 Limits (2)	Units
V_{HYST}	Thermal Hysteresis (5)	$\Delta T = -40^\circ\text{C}$ to $+125^\circ\text{C}$	0.08			%

- (5) Thermal hysteresis is defined as the difference in voltage measured at $+25^\circ\text{C}$ after cycling to temperature -40°C and the 25°C measurement after cycling to temperature $+125^\circ\text{C}$.

LM4040-5.0 Electrical Characteristics

V_R Tolerance Grades 'A' and 'B'; Temperature Grade 'I'

Boldface limits apply for $T_A = T_J = T_{MIN}$ to T_{MAX} ; all other limits $T_A = T_J = 25^\circ\text{C}$. The grades A and B designate initial Reverse Breakdown Voltage tolerances of $\pm 0.1\%$ and $\pm 0.2\%$, respectively.

Symbol	Parameter	Conditions	Typical (1)	LM4040AIM3 LM4040AIZ — Limits (2)	LM4040BIM3 LM4040BIZ LM4040BIM7 Limits (2)	Units
V_R	Reverse Breakdown Voltage	$I_R = 100 \mu\text{A}$	5.000			V
	Reverse Breakdown Voltage Tolerance (3)	$I_R = 100 \mu\text{A}$		± 5.0 ± 38	± 10 ± 43	mV (max) mV (max)
I_{RMIN}	Minimum Operating Current		54			μA
				74	74	μA (max)
				80	80	μA (max)
$\Delta V_R/\Delta T$	Average Reverse Breakdown Voltage Temperature Coefficient (3)	$I_R = 10 \text{ mA}$	± 30			ppm/ $^\circ\text{C}$
		$I_R = 1 \text{ mA}$	± 20	± 100	± 100	ppm/ $^\circ\text{C}$ (max)
		$I_R = 100 \mu\text{A}$	± 20			ppm/ $^\circ\text{C}$
$\Delta V_R/\Delta I_R$	Reverse Breakdown Voltage Change with Operating Current Change (4)	$I_{RMIN} \leq I_R \leq 1 \text{ mA}$	0.5			mV
				1.0	1.0	mV (max)
				1.4	1.4	mV (max)
		$1 \text{ mA} \leq I_R \leq 15 \text{ mA}$	3.5			mV
				8.0	8.0	mV (max)
		12.0	12.0	mV (max)		
Z_R	Reverse Dynamic Impedance	$I_R = 1 \text{ mA}$, $f = 120 \text{ Hz}$, $I_{AC} = 0.1 I_R$	0.5			Ω
				1.1	1.1	Ω (max)
e_N	Wideband Noise	$I_R = 100 \mu\text{A}$ $10 \text{ Hz} \leq f \leq 10 \text{ kHz}$	80			μV_{rms}
ΔV_R	Reverse Breakdown Voltage Long Term Stability	$t = 1000 \text{ hrs}$ $T = 25^\circ\text{C} \pm 0.1^\circ\text{C}$ $I_R = 100 \mu\text{A}$	120			ppm

(1) Typicals are at $T_J = 25^\circ\text{C}$ and represent most likely parametric norm.

(2) Limits are 100% production tested at 25°C . Limits over temperature are guaranteed through correlation using Statistical Quality Control (SQC) methods. The limits are used to calculate National's AOQL.

(3) The boldface (over-temperature) limit for Reverse Breakdown Voltage Tolerance is defined as the room temperature Reverse Breakdown Voltage Tolerance $\pm[(\Delta V_R/\Delta T)(\max\Delta T)(V_R)]$. Where, $\Delta V_R/\Delta T$ is the V_R temperature coefficient, $\max\Delta T$ is the maximum difference in temperature from the reference point of 25°C to T_{MIN} or T_{MAX} , and V_R is the reverse breakdown voltage. The total over-temperature tolerance for the different grades in the industrial temperature range where $\max\Delta T = 65^\circ\text{C}$ is shown below:

$$\text{A-grade: } \pm 0.75\% = \pm 0.1\% \pm 100 \text{ ppm}/^\circ\text{C} \times 65^\circ\text{C}$$

$$\text{B-grade: } \pm 0.85\% = \pm 0.2\% \pm 100 \text{ ppm}/^\circ\text{C} \times 65^\circ\text{C}$$

$$\text{C-grade: } \pm 1.15\% = \pm 0.5\% \pm 100 \text{ ppm}/^\circ\text{C} \times 65^\circ\text{C}$$

$$\text{D-grade: } \pm 1.98\% = \pm 1.0\% \pm 150 \text{ ppm}/^\circ\text{C} \times 65^\circ\text{C}$$

$$\text{E-grade: } \pm 2.98\% = \pm 2.0\% \pm 150 \text{ ppm}/^\circ\text{C} \times 65^\circ\text{C}$$

The total over-temperature tolerance for the different grades in the extended temperature range where $\max\Delta T = 100^\circ\text{C}$ is shown below:

$$\text{C-grade: } \pm 1.5\% = \pm 0.5\% \pm 100 \text{ ppm}/^\circ\text{C} \times 100^\circ\text{C}$$

$$\text{D-grade: } \pm 2.5\% = \pm 1.0\% \pm 150 \text{ ppm}/^\circ\text{C} \times 100^\circ\text{C}$$

$$\text{E-grade: } \pm 3.5\% = \pm 2.0\% \pm 150 \text{ ppm}/^\circ\text{C} \times 100^\circ\text{C}$$

, as an example, the A-grade LM4040-2.5 has an over-temperature Reverse Breakdown Voltage tolerance of $\pm 2.5\text{V} \times 0.75\% = \pm 19 \text{ mV}$.

(4) Load regulation is measured on pulse basis from no load to the specified load current. Output changes due to die temperature change must be taken into account separately.

LM4040-5.0 Electrical Characteristics

V_R Tolerance Grades 'A' and 'B'; Temperature Grade 'I' (continued)

Boldface limits apply for $T_A = T_J = T_{MIN}$ to T_{MAX} ; all other limits $T_A = T_J = 25^\circ\text{C}$. The grades A and B designate initial Reverse Breakdown Voltage tolerances of $\pm 0.1\%$ and $\pm 0.2\%$, respectively.

Symbol	Parameter	Conditions	Typical (1)	LM4040AIM3 LM4040AIZ — Limits (2)	LM4040BIM3 LM4040BIZ LM4040BIM7 Limits (2)	Units
V_{HYST}	Thermal Hysteresis (5)	$\Delta T = -40^\circ\text{C}$ to $+125^\circ\text{C}$	0.08			%

- (5) Thermal hysteresis is defined as the difference in voltage measured at $+25^\circ\text{C}$ after cycling to temperature -40°C and the 25°C measurement after cycling to temperature $+125^\circ\text{C}$.

LM4040-5.0 Electrical Characteristics

V_R Tolerance Grades 'C' and 'D'; Temperature Grade 'I'

Boldface limits apply for $T_A = T_J = T_{MIN}$ to T_{MAX} ; all other limits $T_A = T_J = 25^\circ\text{C}$. The grades C and D designate initial Reverse Breakdown Voltage tolerances of $\pm 0.5\%$ and $\pm 1.0\%$, respectively.

Symbol	Parameter	Conditions	Typical (1)	LM4040CIM3 LM4040CIZ LM4040CIM7 Limits (2)	LM4040DIM3 LM4040DI2 LM4040DIM7 Limits (2)	Units
V_R	Reverse Breakdown Voltage	$I_R = 100 \mu\text{A}$	5.000			V
	Reverse Breakdown Voltage Tolerance (3)	$I_R = 100 \mu\text{A}$		± 25 ± 58	± 50 ± 99	mV (max) mV (max)
I_{RMIN}	Minimum Operating Current		54			μA
				74	79	μA (max)
				80	85	μA (max)
$\Delta V_R/\Delta T$	Average Reverse Breakdown Voltage Temperature Coefficient (3)	$I_R = 10 \text{ mA}$	± 30			ppm/ $^\circ\text{C}$
		$I_R = 1 \text{ mA}$	± 20	± 100	± 150	ppm/ $^\circ\text{C}$ (max)
		$I_R = 100 \mu\text{A}$	± 20			ppm/ $^\circ\text{C}$
$\Delta V_R/\Delta I_R$	Reverse Breakdown Voltage Change with Operating Current Change (4)	$I_{RMIN} \leq I_R \leq 1 \text{ mA}$	0.5			mV
				1.0	1.3	mV (max)
				1.4	1.8	mV (max)
		$1 \text{ mA} \leq I_R \leq 15 \text{ mA}$	3.5			mV
				8.0	10.0	mV (max)
		12.0	15.0	mV (max)		
Z_R	Reverse Dynamic Impedance	$I_R = 1 \text{ mA}$, $f = 120 \text{ Hz}$, $I_{AC} = 0.1 I_R$	0.5			Ω
				1.1	1.5	Ω (max)
e_N	Wideband Noise	$I_R = 100 \mu\text{A}$ $10 \text{ Hz} \leq f \leq 10 \text{ kHz}$	80			μV_{rms}
ΔV_R	Reverse Breakdown Voltage Long Term Stability	$t = 1000 \text{ hrs}$ $T = 25^\circ\text{C} \pm 0.1^\circ\text{C}$ $I_R = 100 \mu\text{A}$	120			ppm

(1) Typicals are at $T_J = 25^\circ\text{C}$ and represent most likely parametric norm.

(2) Limits are 100% production tested at 25°C . Limits over temperature are guaranteed through correlation using Statistical Quality Control (SQC) methods. The limits are used to calculate National's AOQL.

(3) The boldface (over-temperature) limit for Reverse Breakdown Voltage Tolerance is defined as the room temperature Reverse Breakdown Voltage Tolerance $\pm[(\Delta V_R/\Delta T)(\max\Delta T)(V_R)]$. Where, $\Delta V_R/\Delta T$ is the V_R temperature coefficient, $\max\Delta T$ is the maximum difference in temperature from the reference point of 25°C to T_{MIN} or T_{MAX} , and V_R is the reverse breakdown voltage. The total over-temperature tolerance for the different grades in the industrial temperature range where $\max\Delta T = 65^\circ\text{C}$ is shown below:

$$\text{A-grade: } \pm 0.75\% = \pm 0.1\% \pm 100 \text{ ppm}/^\circ\text{C} \times 65^\circ\text{C}$$

$$\text{B-grade: } \pm 0.85\% = \pm 0.2\% \pm 100 \text{ ppm}/^\circ\text{C} \times 65^\circ\text{C}$$

$$\text{C-grade: } \pm 1.15\% = \pm 0.5\% \pm 100 \text{ ppm}/^\circ\text{C} \times 65^\circ\text{C}$$

$$\text{D-grade: } \pm 1.98\% = \pm 1.0\% \pm 150 \text{ ppm}/^\circ\text{C} \times 65^\circ\text{C}$$

$$\text{E-grade: } \pm 2.98\% = \pm 2.0\% \pm 150 \text{ ppm}/^\circ\text{C} \times 65^\circ\text{C}$$

The total over-temperature tolerance for the different grades in the extended temperature range where $\max\Delta T = 100^\circ\text{C}$ is shown below:

$$\text{C-grade: } \pm 1.5\% = \pm 0.5\% \pm 100 \text{ ppm}/^\circ\text{C} \times 100^\circ\text{C}$$

$$\text{D-grade: } \pm 2.5\% = \pm 1.0\% \pm 150 \text{ ppm}/^\circ\text{C} \times 100^\circ\text{C}$$

$$\text{E-grade: } \pm 3.5\% = \pm 2.0\% \pm 150 \text{ ppm}/^\circ\text{C} \times 100^\circ\text{C}$$

, as an example, the A-grade LM4040-2.5 has an over-temperature Reverse Breakdown Voltage tolerance of $\pm 2.5\% \times 0.75\% = \pm 19 \text{ mV}$.

(4) Load regulation is measured on pulse basis from no load to the specified load current. Output changes due to die temperature change must be taken into account separately.

LM4040-5.0 Electrical Characteristics

V_R Tolerance Grades 'C' and 'D'; Temperature Grade 'I' (continued)

Boldface limits apply for $T_A = T_J = T_{MIN}$ to T_{MAX} ; all other limits $T_A = T_J = 25^\circ\text{C}$. The grades C and D designate initial Reverse Breakdown Voltage tolerances of $\pm 0.5\%$ and $\pm 1.0\%$, respectively.

Symbol	Parameter	Conditions	Typical (1)	LM4040CIM3 LM4040CIZ LM4040CIM7 Limits (2)	LM4040DIM3 LM4040DIZ LM4040DIM7 Limits (2)	Units
V_{HYST}	Thermal Hysteresis (5)	$\Delta T = -40^\circ\text{C}$ to $+125^\circ\text{C}$	0.08			%

(5) Thermal hysteresis is defined as the difference in voltage measured at $+25^\circ\text{C}$ after cycling to temperature -40°C and the 25°C measurement after cycling to temperature $+125^\circ\text{C}$.

LM4040-5.0 Electrical Characteristics

V_R Tolerance Grades 'C' and 'D'; Temperature Grade 'E'

Boldface limits apply for $T_A = T_J = T_{MIN}$ to T_{MAX} ; all other limits $T_A = T_J = 25^\circ\text{C}$. The grades C and D designate initial Reverse Breakdown Voltage tolerances of $\pm 0.5\%$ and $\pm 1.0\%$, respectively.

Symbol	Parameter	Conditions	Typical	LM4040CEM3	LM4040DEM3	Units
				Limits	Limits	
				(1)	(1)	
V_R	Reverse Breakdown Voltage	$I_R = 100 \mu\text{A}$	5.000			V
	Reverse Breakdown Voltage Tolerance ⁽²⁾	$I_R = 100 \mu\text{A}$		± 25	± 50	mV (max)
I_{RMIN}	Minimum Operating Current		54			μA
				74	79	μA (max)
				83	88	μA (max)
$\Delta V_R/\Delta T$	Average Reverse Breakdown Voltage Temperature Coefficient ⁽²⁾	$I_R = 10 \text{ mA}$	± 30			ppm/ $^\circ\text{C}$
		$I_R = 1 \text{ mA}$	± 20	± 100	± 150	ppm/ $^\circ\text{C}$ (max)
		$I_R = 100 \mu\text{A}$	± 20			ppm/ $^\circ\text{C}$
$\Delta V_R/\Delta I_R$	Reverse Breakdown Voltage Change with Operating Current Change ⁽³⁾	$I_{RMIN} \leq I_R \leq 1 \text{ mA}$	0.5			mV
				1.0	1.0	mV (max)
		$1 \text{ mA} \leq I_R \leq 15 \text{ mA}$		1.4	1.8	mV (max)
			3.5			mV
				8.0	8.0	mV (max)
		12.0	15.0	mV (max)		
Z_R	Reverse Dynamic Impedance	$I_R = 1 \text{ mA}$, $f = 120 \text{ Hz}$, $I_{AC} = 0.1 I_R$	0.5			Ω
				1.1	1.1	Ω (max)
e_N	Wideband Noise	$I_R = 100 \mu\text{A}$ $10 \text{ Hz} \leq f \leq 10 \text{ kHz}$	80			μV_{rms}
ΔV_R	Reverse Breakdown Voltage Long Term Stability	$t = 1000 \text{ hrs}$ $T = 25^\circ\text{C} \pm 0.1^\circ\text{C}$ $I_R = 100 \mu\text{A}$	120			ppm

- (1) Limits are 100% production tested at 25°C . Limits over temperature are guaranteed through correlation using Statistical Quality Control (SQC) methods. The limits are used to calculate National's AOQL.
- (2) The boldface (over-temperature) limit for Reverse Breakdown Voltage Tolerance is defined as the room temperature Reverse Breakdown Voltage Tolerance $\pm[(\Delta V_R/\Delta T)(\max\Delta T)(V_R)]$. Where, $\Delta V_R/\Delta T$ is the V_R temperature coefficient, $\max\Delta T$ is the maximum difference in temperature from the reference point of 25°C to T_{MIN} or T_{MAX} , and V_R is the reverse breakdown voltage. The total over-temperature tolerance for the different grades in the industrial temperature range where $\max\Delta T = 65^\circ\text{C}$ is shown below:

$$\text{A-grade: } \pm 0.75\% = \pm 0.1\% \pm 100 \text{ ppm}/^\circ\text{C} \times 65^\circ\text{C}$$

$$\text{B-grade: } \pm 0.85\% = \pm 0.2\% \pm 100 \text{ ppm}/^\circ\text{C} \times 65^\circ\text{C}$$

$$\text{C-grade: } \pm 1.15\% = \pm 0.5\% \pm 100 \text{ ppm}/^\circ\text{C} \times 65^\circ\text{C}$$

$$\text{D-grade: } \pm 1.98\% = \pm 1.0\% \pm 150 \text{ ppm}/^\circ\text{C} \times 65^\circ\text{C}$$

$$\text{E-grade: } \pm 2.98\% = \pm 2.0\% \pm 150 \text{ ppm}/^\circ\text{C} \times 65^\circ\text{C}$$

The total over-temperature tolerance for the different grades in the extended temperature range where $\max\Delta T = 100^\circ\text{C}$ is shown below:

$$\text{C-grade: } \pm 1.5\% = \pm 0.5\% \pm 100 \text{ ppm}/^\circ\text{C} \times 100^\circ\text{C}$$

$$\text{D-grade: } \pm 2.5\% = \pm 1.0\% \pm 150 \text{ ppm}/^\circ\text{C} \times 100^\circ\text{C}$$

$$\text{E-grade: } \pm 3.5\% = \pm 2.0\% \pm 150 \text{ ppm}/^\circ\text{C} \times 100^\circ\text{C}$$

, as an example, the A-grade LM4040-2.5 has an over-temperature Reverse Breakdown Voltage tolerance of $\pm 2.5\% \times 0.75\% = \pm 19 \text{ mV}$.

- (3) Load regulation is measured on pulse basis from no load to the specified load current. Output changes due to die temperature change must be taken into account separately.

LM4040-5.0 Electrical Characteristics V_R Tolerance Grades 'C' and 'D'; Temperature Grade 'E' (continued)

Boldface limits apply for T_A = T_J = T_{MIN} to T_{MAX}; all other limits T_A = T_J = 25°C. The grades C and D designate initial Reverse Breakdown Voltage tolerances of ±0.5% and ±1.0%, respectively.

Symbol	Parameter	Conditions	Typical	LM4040CEM3	LM4040DEM3	Units
				Limits	Limits	
				(1)	(1)	
V _{HYST}	Thermal Hysteresis (4)	ΔT = -40°C to +125°C	0.08			%

(4) Thermal hysteresis is defined as the difference in voltage measured at +25°C after cycling to temperature -40°C and the 25°C measurement after cycling to temperature +125°C.

LM4040-8.2 Electrical Characteristics

V_R Tolerance Grades 'A' and 'B'; Temperature Grade 'I'

Boldface limits apply for $T_A = T_J = T_{MIN}$ to T_{MAX} ; all other limits $T_A = T_J = 25^\circ\text{C}$. The grades A and B designate initial Reverse Breakdown Voltage tolerances of $\pm 0.1\%$ and $\pm 0.2\%$, respectively.

Symbol	Parameter	Conditions	Typical (1)	LM4040AIM3	LM4040BIM3	Units
				LM4040AIZ	LM4040BIZ	
				Limits	Limits	
				(2)	(2)	
V_R	Reverse Breakdown Voltage	$I_R = 150 \mu\text{A}$	8.192			V
	Reverse Breakdown Voltage Tolerance (3)	$I_R = 150 \mu\text{A}$		± 8.2	± 16	mV (max)
I_{RMIN}	Minimum Operating Current		67			μA
				91	91	μA (max)
				95	95	μA (max)
$\Delta V_R/\Delta T$	Average Reverse Breakdown Voltage Temperature Coefficient (3)	$I_R = 10 \text{ mA}$	± 40			ppm/ $^\circ\text{C}$
		$I_R = 1 \text{ mA}$	± 20	± 100	± 100	ppm/ $^\circ\text{C}$ (max)
		$I_R = 150 \mu\text{A}$	± 20			ppm/ $^\circ\text{C}$
$\Delta V_R/\Delta I_R$	Reverse Breakdown Voltage Change with Operating Current Change (4)	$I_{RMIN} \leq I_R \leq 1 \text{ mA}$	0.6			mV
				1.3	1.3	mV (max)
				2.5	2.5	mV (max)
		$1 \text{ mA} \leq I_R \leq 15 \text{ mA}$	7.0			mV
				10.0	10.0	mV (max)
				18.0	18.0	mV (max)
Z_R	Reverse Dynamic Impedance	$I_R = 1 \text{ mA}$, $f = 120 \text{ Hz}$, $I_{AC} = 0.1 I_R$	0.6			Ω
				1.5	1.5	Ω (max)
e_N	Wideband Noise	$I_R = 150 \mu\text{A}$ $10 \text{ Hz} \leq f \leq 10 \text{ kHz}$	130			μV_{rms}
ΔV_R	Reverse Breakdown Voltage Long Term Stability	$t = 1000 \text{ hrs}$ $T = 25^\circ\text{C} \pm 0.1^\circ\text{C}$ $I_R = 150 \mu\text{A}$	120			ppm

- (1) Typicals are at $T_J = 25^\circ\text{C}$ and represent most likely parametric norm.
(2) Limits are 100% production tested at 25°C . Limits over temperature are guaranteed through correlation using Statistical Quality Control (SQC) methods. The limits are used to calculate National's AOQL.
(3) The boldface (over-temperature) limit for Reverse Breakdown Voltage Tolerance is defined as the room temperature Reverse Breakdown Voltage Tolerance $\pm[(\Delta V_R/\Delta T)(\max\Delta T)(V_R)]$. Where, $\Delta V_R/\Delta T$ is the V_R temperature coefficient, $\max\Delta T$ is the maximum difference in temperature from the reference point of 25°C to T_{MIN} or T_{MAX} , and V_R is the reverse breakdown voltage. The total over-temperature tolerance for the different grades in the industrial temperature range where $\max\Delta T = 65^\circ\text{C}$ is shown below:

$$\text{A-grade: } \pm 0.75\% = \pm 0.1\% \pm 100 \text{ ppm}/^\circ\text{C} \times 65^\circ\text{C}$$

$$\text{B-grade: } \pm 0.85\% = \pm 0.2\% \pm 100 \text{ ppm}/^\circ\text{C} \times 65^\circ\text{C}$$

$$\text{C-grade: } \pm 1.15\% = \pm 0.5\% \pm 100 \text{ ppm}/^\circ\text{C} \times 65^\circ\text{C}$$

$$\text{D-grade: } \pm 1.98\% = \pm 1.0\% \pm 150 \text{ ppm}/^\circ\text{C} \times 65^\circ\text{C}$$

$$\text{E-grade: } \pm 2.98\% = \pm 2.0\% \pm 150 \text{ ppm}/^\circ\text{C} \times 65^\circ\text{C}$$

The total over-temperature tolerance for the different grades in the extended temperature range where $\max\Delta T = 100^\circ\text{C}$ is shown below:

$$\text{C-grade: } \pm 1.5\% = \pm 0.5\% \pm 100 \text{ ppm}/^\circ\text{C} \times 100^\circ\text{C}$$

$$\text{D-grade: } \pm 2.5\% = \pm 1.0\% \pm 150 \text{ ppm}/^\circ\text{C} \times 100^\circ\text{C}$$

$$\text{E-grade: } \pm 3.5\% = \pm 2.0\% \pm 150 \text{ ppm}/^\circ\text{C} \times 100^\circ\text{C}$$

, as an example, the A-grade LM4040-2.5 has an over-temperature Reverse Breakdown Voltage tolerance of $\pm 2.5\text{V} \times 0.75\% = \pm 19 \text{ mV}$.

- (4) Load regulation is measured on pulse basis from no load to the specified load current. Output changes due to die temperature change must be taken into account separately.

LM4040-8.2 Electrical Characteristics

V_R Tolerance Grades 'A' and 'B'; Temperature Grade 'I' (continued)

Boldface limits apply for $T_A = T_J = T_{MIN}$ to T_{MAX} ; all other limits $T_A = T_J = 25^\circ\text{C}$. The grades A and B designate initial Reverse Breakdown Voltage tolerances of $\pm 0.1\%$ and $\pm 0.2\%$, respectively.

Symbol	Parameter	Conditions	Typical (1)	LM4040AIM3	LM4040BIM3	Units
				LM4040AIZ	LM4040BIZ	
				Limits	Limits	
				(2)	(2)	
V_{HYST}	Thermal Hysteresis (5)	$\Delta T = -40^\circ\text{C}$ to $+125^\circ\text{C}$	0.08			%

- (5) Thermal hysteresis is defined as the difference in voltage measured at $+25^\circ\text{C}$ after cycling to temperature -40°C and the 25°C measurement after cycling to temperature $+125^\circ\text{C}$.

LM4040-8.2 Electrical Characteristics

V_R Tolerance Grades 'C' and 'D'; Temperature Grade 'I'

Boldface limits apply for $T_A = T_J = T_{MIN}$ to T_{MAX} ; all other limits $T_A = T_J = 25^\circ\text{C}$. The grades C and D designate initial Reverse Breakdown Voltage tolerances of $\pm 0.5\%$ and $\pm 1.0\%$, respectively.

Symbol	Parameter	Conditions	Typical (1)	LM4040CIM3	LM4040DIM3	Units
				LM4040CIZ	LM4040DIZ	
				Limits	Limits	
				(2)	(2)	
V_R	Reverse Breakdown Voltage	$I_R = 150 \mu\text{A}$	8.192			V
	Reverse Breakdown Voltage Tolerance (3)	$I_R = 150 \mu\text{A}$		± 41	± 82	mV (max)
I_{RMIN}	Minimum Operating Current		67			μA
				91	96	μA (max)
				95	100	μA (max)
$\Delta V_R/\Delta T$	Average Reverse Breakdown Voltage Temperature Coefficient (3)	$I_R = 10 \text{ mA}$	± 40			ppm/ $^\circ\text{C}$
		$I_R = 1 \text{ mA}$	± 20	± 100	± 150	ppm/ $^\circ\text{C}$ (max)
		$I_R = 150 \mu\text{A}$	± 20			ppm/ $^\circ\text{C}$
$\Delta V_R/\Delta I_R$	Reverse Breakdown Voltage Change with Operating Current Change (4)	$I_{RMIN} \leq I_R \leq 1 \text{ mA}$	0.6			mV
				1.3	1.7	mV (max)
				2.5	3.0	mV (max)
		$1 \text{ mA} \leq I_R \leq 15 \text{ mA}$	7.0			mV
				10.0	15.0	mV (max)
				18.0	24.0	mV (max)
Z_R	Reverse Dynamic Impedance	$I_R = 1 \text{ mA}, f = 120 \text{ Hz}, I_{AC} = 0.1 I_R$	0.6			Ω
				1.5	1.9	Ω (max)
e_N	Wideband Noise	$I_R = 150 \mu\text{A}$ $10 \text{ Hz} \leq f \leq 10 \text{ kHz}$	130			μV_{rms}
ΔV_R	Reverse Breakdown Voltage Long Term Stability	$t = 1000 \text{ hrs}$ $T = 25^\circ\text{C} \pm 0.1^\circ\text{C}$ $I_R = 150 \mu\text{A}$	120			ppm

- (1) Typicals are at $T_J = 25^\circ\text{C}$ and represent most likely parametric norm.
(2) Limits are 100% production tested at 25°C . Limits over temperature are guaranteed through correlation using Statistical Quality Control (SQC) methods. The limits are used to calculate National's AOQL.
(3) The boldface (over-temperature) limit for Reverse Breakdown Voltage Tolerance is defined as the room temperature Reverse Breakdown Voltage Tolerance $\pm[(\Delta V_R/\Delta T)(\max\Delta T)(V_R)]$. Where, $\Delta V_R/\Delta T$ is the V_R temperature coefficient, $\max\Delta T$ is the maximum difference in temperature from the reference point of 25°C to T_{MIN} or T_{MAX} , and V_R is the reverse breakdown voltage. The total over-temperature tolerance for the different grades in the industrial temperature range where $\max\Delta T = 65^\circ\text{C}$ is shown below:

$$\text{A-grade: } \pm 0.75\% = \pm 0.1\% \pm 100 \text{ ppm}/^\circ\text{C} \times 65^\circ\text{C}$$

$$\text{B-grade: } \pm 0.85\% = \pm 0.2\% \pm 100 \text{ ppm}/^\circ\text{C} \times 65^\circ\text{C}$$

$$\text{C-grade: } \pm 1.15\% = \pm 0.5\% \pm 100 \text{ ppm}/^\circ\text{C} \times 65^\circ\text{C}$$

$$\text{D-grade: } \pm 1.98\% = \pm 1.0\% \pm 150 \text{ ppm}/^\circ\text{C} \times 65^\circ\text{C}$$

$$\text{E-grade: } \pm 2.98\% = \pm 2.0\% \pm 150 \text{ ppm}/^\circ\text{C} \times 65^\circ\text{C}$$

The total over-temperature tolerance for the different grades in the extended temperature range where $\max\Delta T = 100^\circ\text{C}$ is shown below:

$$\text{C-grade: } \pm 1.5\% = \pm 0.5\% \pm 100 \text{ ppm}/^\circ\text{C} \times 100^\circ\text{C}$$

$$\text{D-grade: } \pm 2.5\% = \pm 1.0\% \pm 150 \text{ ppm}/^\circ\text{C} \times 100^\circ\text{C}$$

$$\text{E-grade: } \pm 3.5\% = \pm 2.0\% \pm 150 \text{ ppm}/^\circ\text{C} \times 100^\circ\text{C}$$

, as an example, the A-grade LM4040-2.5 has an over-temperature Reverse Breakdown Voltage tolerance of $\pm 2.5\text{V} \times 0.75\% = \pm 19 \text{ mV}$.

- (4) Load regulation is measured on pulse basis from no load to the specified load current. Output changes due to die temperature change must be taken into account separately.

LM4040-8.2 Electrical Characteristics

V_R Tolerance Grades 'C' and 'D'; Temperature Grade 'I' (continued)

Boldface limits apply for $T_A = T_J = T_{MIN}$ to T_{MAX} ; all other limits $T_A = T_J = 25^\circ\text{C}$. The grades C and D designate initial Reverse Breakdown Voltage tolerances of $\pm 0.5\%$ and $\pm 1.0\%$, respectively.

Symbol	Parameter	Conditions	Typical (1)	LM4040CIM3	LM4040DIM3	Units
				LM4040CIZ	LM4040DIZ	
				Limits	Limits	
				(2)	(2)	
V_{HYST}	Thermal Hysteresis (5)	$\Delta T = -40^\circ\text{C}$ to $+125^\circ\text{C}$	0.08			%

(5) Thermal hysteresis is defined as the difference in voltage measured at $+25^\circ\text{C}$ after cycling to temperature -40°C and the 25°C measurement after cycling to temperature $+125^\circ\text{C}$.

LM4040-10.0 Electrical Characteristics

V_R Tolerance Grades 'A' and 'B'; Temperature Grade 'I'

Boldface limits apply for $T_A = T_J = T_{MIN}$ to T_{MAX} ; all other limits $T_A = T_J = 25^\circ\text{C}$. The grades A and B designate initial Reverse Breakdown Voltage tolerances of $\pm 0.1\%$ and $\pm 0.2\%$, respectively.

Symbol	Parameter	Conditions	Typical (1)	LM4040AIM3	LM4040BIM3	Units
				LM4040AIZ	LM4040BIZ	
				Limits	Limits	
				(2)	(2)	
V_R	Reverse Breakdown Voltage	$I_R = 150 \mu\text{A}$	10.00			V
	Reverse Breakdown Voltage Tolerance (3)	$I_R = 150 \mu\text{A}$		± 10	± 20	mV (max)
I_{RMIN}	Minimum Operating Current		75			μA
				100	100	μA (max)
				103	103	μA (max)
$\Delta V_R/\Delta T$	Average Reverse Breakdown Voltage Temperature Coefficient (3)	$I_R = 10 \text{ mA}$	± 40			ppm/ $^\circ\text{C}$
		$I_R = 1 \text{ mA}$	± 20	± 100	± 100	ppm/ $^\circ\text{C}$ (max)
		$I_R = 150 \mu\text{A}$	± 20			ppm/ $^\circ\text{C}$
$\Delta V_R/\Delta I_R$	Reverse Breakdown Voltage Change with Operating Current Change (4)	$I_{RMIN} \leq I_R \leq 1 \text{ mA}$	0.8			mV
				1.5	1.5	mV (max)
				3.5	3.5	mV (max)
		$1 \text{ mA} \leq I_R \leq 15 \text{ mA}$	8.0			mV
				12.0	12.0	mV (max)
				23.0	23.0	mV (max)
Z_R	Reverse Dynamic Impedance	$I_R = 1 \text{ mA}, f = 120 \text{ Hz}, I_{AC} = 0.1 I_R$	0.7			Ω
				1.7	1.7	Ω (max)
e_N	Wideband Noise	$I_R = 150 \mu\text{A}$ $10 \text{ Hz} \leq f \leq 10 \text{ kHz}$	180			μV_{rms}
ΔV_R	Reverse Breakdown Voltage Long Term Stability	$t = 1000 \text{ hrs}$ $T = 25^\circ\text{C} \pm 0.1^\circ\text{C}$ $I_R = 150 \mu\text{A}$	120			ppm

- (1) Typicals are at $T_J = 25^\circ\text{C}$ and represent most likely parametric norm.
(2) Limits are 100% production tested at 25°C . Limits over temperature are guaranteed through correlation using Statistical Quality Control (SQC) methods. The limits are used to calculate National's AOQL.
(3) The boldface (over-temperature) limit for Reverse Breakdown Voltage Tolerance is defined as the room temperature Reverse Breakdown Voltage Tolerance $\pm[(\Delta V_R/\Delta T)(\max\Delta T)(V_R)]$. Where, $\Delta V_R/\Delta T$ is the V_R temperature coefficient, $\max\Delta T$ is the maximum difference in temperature from the reference point of 25°C to T_{MIN} or T_{MAX} , and V_R is the reverse breakdown voltage. The total over-temperature tolerance for the different grades in the industrial temperature range where $\max\Delta T = 65^\circ\text{C}$ is shown below:

$$\text{A-grade: } \pm 0.75\% = \pm 0.1\% \pm 100 \text{ ppm}/^\circ\text{C} \times 65^\circ\text{C}$$

$$\text{B-grade: } \pm 0.85\% = \pm 0.2\% \pm 100 \text{ ppm}/^\circ\text{C} \times 65^\circ\text{C}$$

$$\text{C-grade: } \pm 1.15\% = \pm 0.5\% \pm 100 \text{ ppm}/^\circ\text{C} \times 65^\circ\text{C}$$

$$\text{D-grade: } \pm 1.98\% = \pm 1.0\% \pm 150 \text{ ppm}/^\circ\text{C} \times 65^\circ\text{C}$$

$$\text{E-grade: } \pm 2.98\% = \pm 2.0\% \pm 150 \text{ ppm}/^\circ\text{C} \times 65^\circ\text{C}$$

The total over-temperature tolerance for the different grades in the extended temperature range where $\max\Delta T = 100^\circ\text{C}$ is shown below:

$$\text{C-grade: } \pm 1.5\% = \pm 0.5\% \pm 100 \text{ ppm}/^\circ\text{C} \times 100^\circ\text{C}$$

$$\text{D-grade: } \pm 2.5\% = \pm 1.0\% \pm 150 \text{ ppm}/^\circ\text{C} \times 100^\circ\text{C}$$

$$\text{E-grade: } \pm 3.5\% = \pm 2.0\% \pm 150 \text{ ppm}/^\circ\text{C} \times 100^\circ\text{C}$$

, as an example, the A-grade LM4040-2.5 has an over-temperature Reverse Breakdown Voltage tolerance of $\pm 2.5\text{V} \times 0.75\% = \pm 19 \text{ mV}$.

- (4) Load regulation is measured on pulse basis from no load to the specified load current. Output changes due to die temperature change must be taken into account separately.

LM4040-10.0 Electrical Characteristics
V_R Tolerance Grades 'A' and 'B'; Temperature Grade 'I' (continued)

Boldface limits apply for T_A = T_J = T_{MIN} to T_{MAX}; all other limits T_A = T_J = 25°C. The grades A and B designate initial Reverse Breakdown Voltage tolerances of ±0.1% and ±0.2%, respectively.

Symbol	Parameter	Conditions	Typical (1)	LM4040AIM3	LM4040BIM3	Units
				LM4040AIZ	LM4040BIZ	
				Limits	Limits	
				(2)	(2)	
V _{HYST}	Thermal Hysteresis (5)	ΔT = -40°C to +125°C	0.08			%

(5) Thermal hysteresis is defined as the difference in voltage measured at +25°C after cycling to temperature -40°C and the 25°C measurement after cycling to temperature +125°C.

LM4040-10.0 Electrical Characteristics

V_R Tolerance Grades 'C' and 'D'; Temperature Grade 'I'

Boldface limits apply for $T_A = T_J = T_{MIN}$ to T_{MAX} ; all other limits $T_A = T_J = 25^\circ\text{C}$. The grades C and D designate initial Reverse Breakdown Voltage tolerances of $\pm 0.5\%$ and $\pm 1.0\%$, respectively.

Symbol	Parameter	Conditions	Typical (1)	LM4040CIM3	LM4040DIM3	Units
				LM4040CIZ	LM4040DIZ	
				Limits	Limits	
				(2)	(2)	
V_R	Reverse Breakdown Voltage	$I_R = 150 \mu\text{A}$	10.00			V
	Reverse Breakdown Voltage Tolerance (3)	$I_R = 150 \mu\text{A}$		± 50	± 100	mV (max)
I_{RMIN}	Minimum Operating Current		75			μA
				100	110	μA (max)
				103	113	μA (max)
$\Delta V_R/\Delta T$	Average Reverse Breakdown Voltage Temperature Coefficient (3)	$I_R = 10 \text{ mA}$	± 40			ppm/ $^\circ\text{C}$
		$I_R = 1 \text{ mA}$	± 20	± 100	± 150	ppm/ $^\circ\text{C}$ (max)
		$I_R = 150 \mu\text{A}$	± 20			ppm/ $^\circ\text{C}$
$\Delta V_R/\Delta I_R$	Reverse Breakdown Voltage Change with Operating Current Change (4)	$I_{RMIN} \leq I_R \leq 1 \text{ mA}$	0.8			mV
				1.5	2.0	mV (max)
				3.5	4.0	mV (max)
		$1 \text{ mA} \leq I_R \leq 15 \text{ mA}$	8.0			mV
				12.0	18.0	mV (max)
				23.0	29.0	mV (max)
Z_R	Reverse Dynamic Impedance	$I_R = 1 \text{ mA}, f = 120 \text{ Hz}, I_{AC} = 0.1 I_R$	0.7			Ω
				1.7	2.3	Ω (max)
e_N	Wideband Noise	$I_R = 150 \mu\text{A}$ $10 \text{ Hz} \leq f \leq 10 \text{ kHz}$	180			μV_{rms}
ΔV_R	Reverse Breakdown Voltage Long Term Stability	$t = 1000 \text{ hrs}$ $T = 25^\circ\text{C} \pm 0.1^\circ\text{C}$ $I_R = 150 \mu\text{A}$	120			ppm

- (1) Typicals are at $T_J = 25^\circ\text{C}$ and represent most likely parametric norm.
(2) Limits are 100% production tested at 25°C . Limits over temperature are guaranteed through correlation using Statistical Quality Control (SQC) methods. The limits are used to calculate National's AOQL.
(3) The boldface (over-temperature) limit for Reverse Breakdown Voltage Tolerance is defined as the room temperature Reverse Breakdown Voltage Tolerance $\pm[(\Delta V_R/\Delta T)(\max\Delta T)(V_R)]$. Where, $\Delta V_R/\Delta T$ is the V_R temperature coefficient, $\max\Delta T$ is the maximum difference in temperature from the reference point of 25°C to T_{MIN} or T_{MAX} , and V_R is the reverse breakdown voltage. The total over-temperature tolerance for the different grades in the industrial temperature range where $\max\Delta T = 65^\circ\text{C}$ is shown below:

$$\text{A-grade: } \pm 0.75\% = \pm 0.1\% \pm 100 \text{ ppm}/^\circ\text{C} \times 65^\circ\text{C}$$

$$\text{B-grade: } \pm 0.85\% = \pm 0.2\% \pm 100 \text{ ppm}/^\circ\text{C} \times 65^\circ\text{C}$$

$$\text{C-grade: } \pm 1.15\% = \pm 0.5\% \pm 100 \text{ ppm}/^\circ\text{C} \times 65^\circ\text{C}$$

$$\text{D-grade: } \pm 1.98\% = \pm 1.0\% \pm 150 \text{ ppm}/^\circ\text{C} \times 65^\circ\text{C}$$

$$\text{E-grade: } \pm 2.98\% = \pm 2.0\% \pm 150 \text{ ppm}/^\circ\text{C} \times 65^\circ\text{C}$$

The total over-temperature tolerance for the different grades in the extended temperature range where $\max\Delta T = 100^\circ\text{C}$ is shown below:

$$\text{C-grade: } \pm 1.5\% = \pm 0.5\% \pm 100 \text{ ppm}/^\circ\text{C} \times 100^\circ\text{C}$$

$$\text{D-grade: } \pm 2.5\% = \pm 1.0\% \pm 150 \text{ ppm}/^\circ\text{C} \times 100^\circ\text{C}$$

$$\text{E-grade: } \pm 3.5\% = \pm 2.0\% \pm 150 \text{ ppm}/^\circ\text{C} \times 100^\circ\text{C}$$

, as an example, the A-grade LM4040-2.5 has an over-temperature Reverse Breakdown Voltage tolerance of $\pm 2.5\text{V} \times 0.75\% = \pm 19 \text{ mV}$.

- (4) Load regulation is measured on pulse basis from no load to the specified load current. Output changes due to die temperature change must be taken into account separately.

LM4040-10.0 Electrical Characteristics

V_R Tolerance Grades 'C' and 'D'; Temperature Grade 'I' (continued)

Boldface limits apply for $T_A = T_J = T_{MIN}$ to T_{MAX} ; all other limits $T_A = T_J = 25^\circ\text{C}$. The grades C and D designate initial Reverse Breakdown Voltage tolerances of $\pm 0.5\%$ and $\pm 1.0\%$, respectively.

Symbol	Parameter	Conditions	Typical (1)	LM4040CIM3	LM4040DIM3	Units
				LM4040CIZ	LM4040DIZ	
				Limits	Limits	
				(2)	(2)	
V_{HYST}	Thermal Hysteresis (5)	$\Delta T = -40^\circ\text{C}$ to $+125^\circ\text{C}$	0.08			%

- (5) Thermal hysteresis is defined as the difference in voltage measured at $+25^\circ\text{C}$ after cycling to temperature -40°C and the 25°C measurement after cycling to temperature $+125^\circ\text{C}$.

Typical Performance Characteristics

Temperature Drift for Different Average Temperature Coefficient

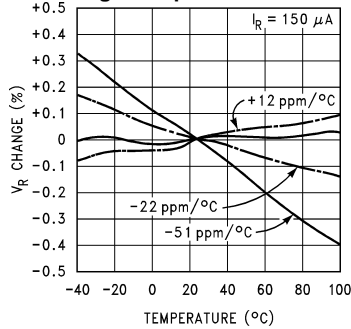

Output Impedance vs Frequency

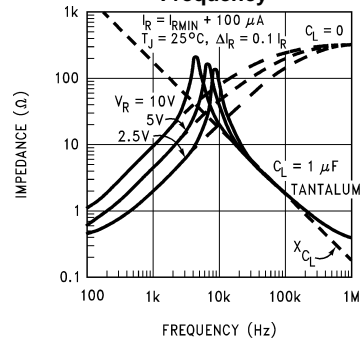

Output Impedance vs Frequency

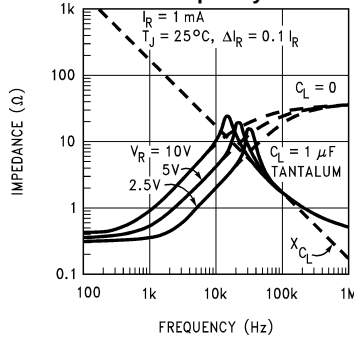

Reverse Characteristics and Minimum Operating Current

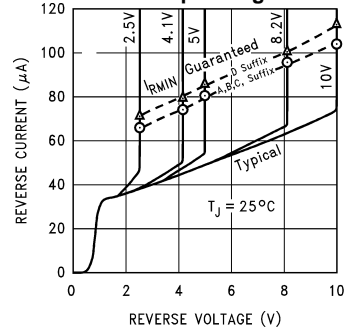

Noise Voltage vs Frequency

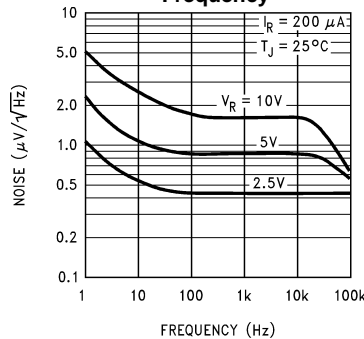

Start-Up Characteristics

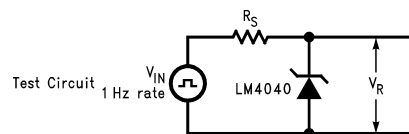

Figure 4. LM4040-2.5 $R_S = 30k$

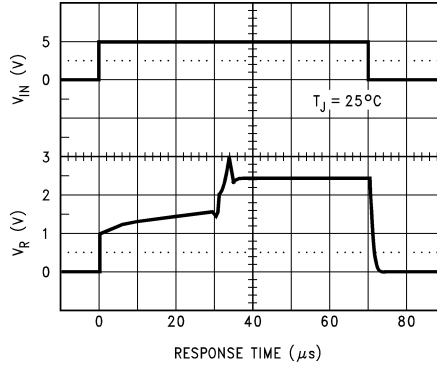

Figure 5. LM4040-5.0 $R_S = 30k$

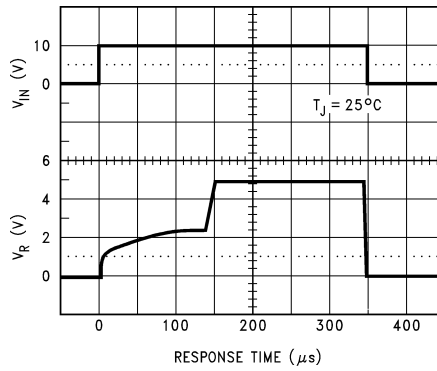
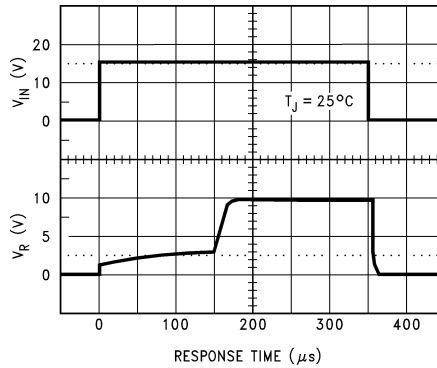
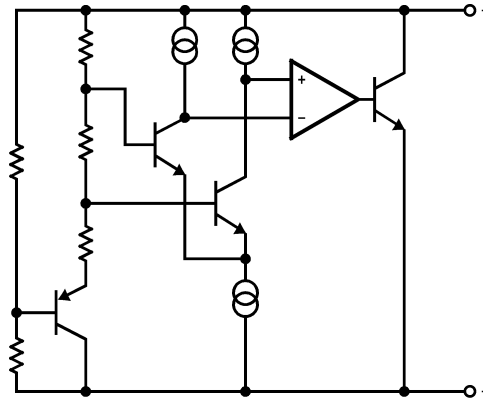

Figure 6. LM4040-10.0 $R_S = 30k$



Functional Block Diagram



Applications Information

The LM4040 is a precision micro-power curvature-corrected bandgap shunt voltage reference. For space critical applications, the LM4040 is available in the sub-miniature SOT-23 and SC70 surface-mount package. The LM4040 has been designed for stable operation without the need of an external capacitor connected between the “+” pin and the “-” pin. If, however, a bypass capacitor is used, the LM4040 remains stable. Reducing design effort is the availability of several fixed reverse breakdown voltages: 2.048V, 2.500V, 3.000V, 4.096V, 5.000V, 6.000, 8.192V, and 10.000V. The minimum operating current increases from 60 μ A for the LM4040-2.048 and LM4040-2.5 to 100 μ A for the LM4040-10.0. All versions have a maximum operating current of 15 mA.

LM4040s in the SOT-23 packages have a parasitic Schottky diode between pin 2 (-) and pin 3 (Die attach interface contact). Therefore, pin 3 of the SOT-23 package must be left floating or connected to pin 2.

LM4040s in the SC70 have a parasitic Schottky diode between pin 1 (-) and pin 2 (Die attach interface contact). Therefore, pin 2 must be left floating or connected to pin1.

The 4.096V version allows single +5V 12-bit ADCs or DACs to operate with an LSB equal to 1 mV. For 12-bit ADCs or DACs that operate on supplies of 10V or greater, the 8.192V version gives 2 mV per LSB.

The typical thermal hysteresis specification is defined as the change in +25°C voltage measured after thermal cycling. The device is thermal cycled to temperature -40°C and then measured at 25°C. Next the device is thermal cycled to temperature +125°C and again measured at 25°C. The resulting V_{OUT} delta shift between the 25°C measurements is thermal hysteresis. Thermal hysteresis is common in precision references and is induced by thermal-mechanical package stress. Changes in environmental storage temperature, operating temperature and board mounting temperature are all factors that can contribute to thermal hysteresis.

In a conventional shunt regulator application (Figure 7), an external series resistor (R_S) is connected between the supply voltage and the LM4040. R_S determines the current that flows through the load (I_L) and the LM4040 (I_Q). Since load current and supply voltage may vary, R_S should be small enough to supply at least the minimum acceptable I_Q to the LM4040 even when the supply voltage is at its minimum and the load current is at its maximum value. When the supply voltage is at its maximum and I_L is at its minimum, R_S should be large enough so that the current flowing through the LM4040 is less than 15 mA.

R_S is determined by the supply voltage, (V_S), the load and operating current, (I_L and I_Q), and the LM4040's reverse breakdown voltage, V_R .

$$R_S = \frac{V_S - V_R}{I_L + I_Q} \quad (1)$$

Typical Applications

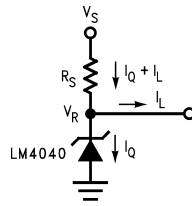
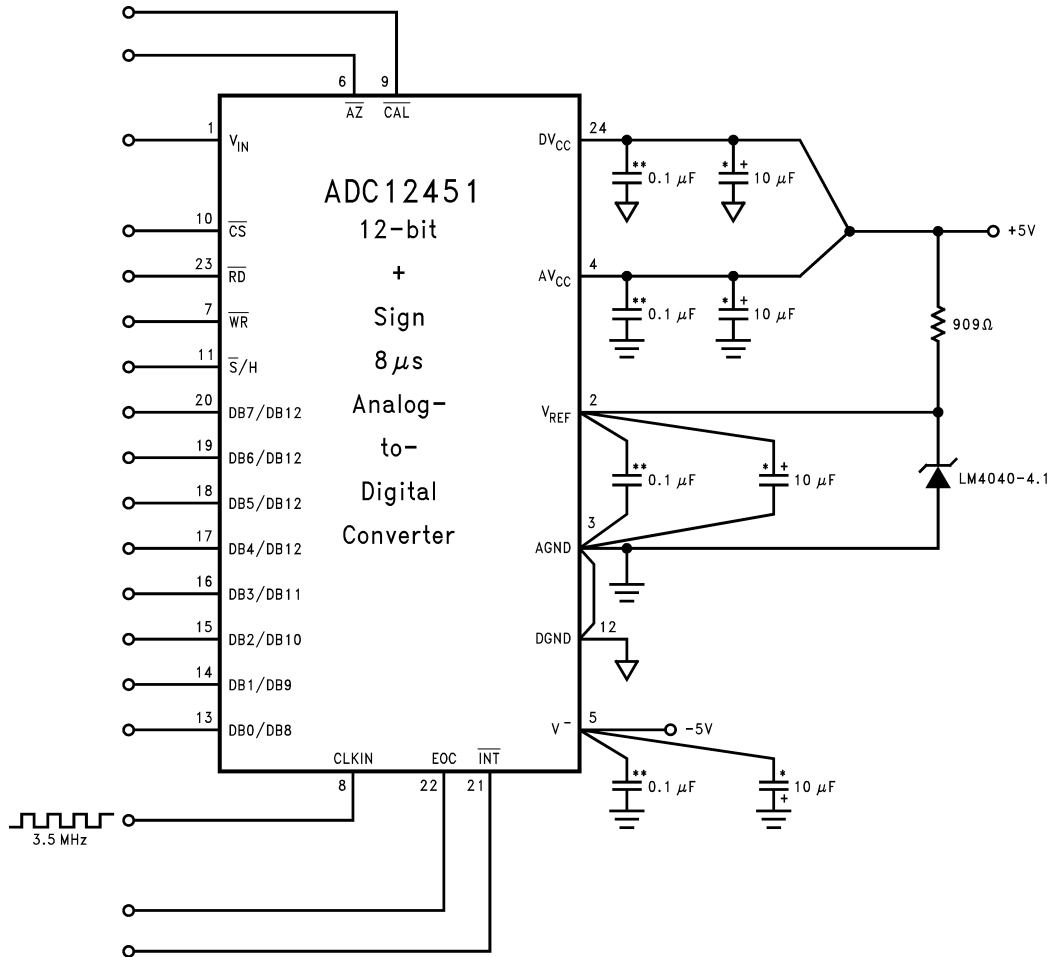

Figure 7. Shunt Regulator



**Ceramic monolithic
*Tantalum

Figure 8. LM4040-4.1's Nominal 4.096 breakdown voltage gives ADC12451 1 mV/LSB

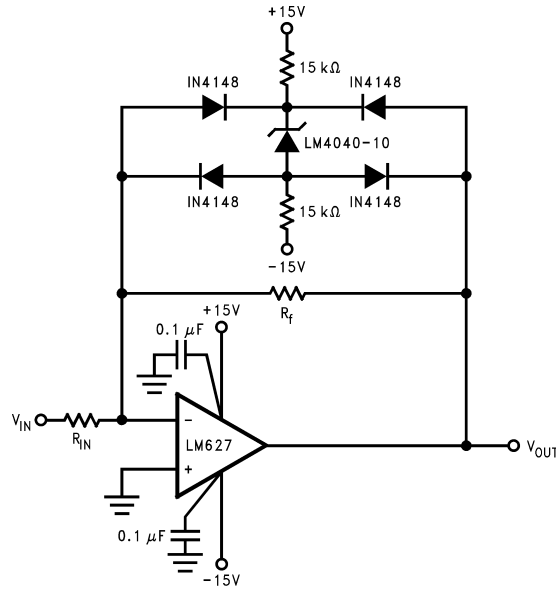

Figure 9. Bounded amplifier reduces saturation-induced delays and can prevent succeeding stage damage.
 Nominal clamping voltage is $\pm 11.5V$ (LM4040's reverse breakdown voltage +2 diode V_F).

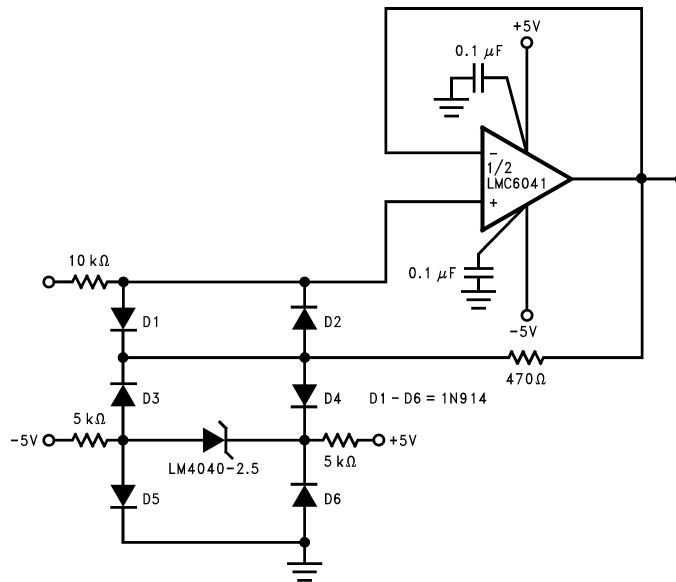

Figure 10. Protecting Op Amp input. The bounding voltage is $\pm 4V$ with the LM4040-2.5
 (LM4040's reverse breakdown voltage + 3 diode V_F).

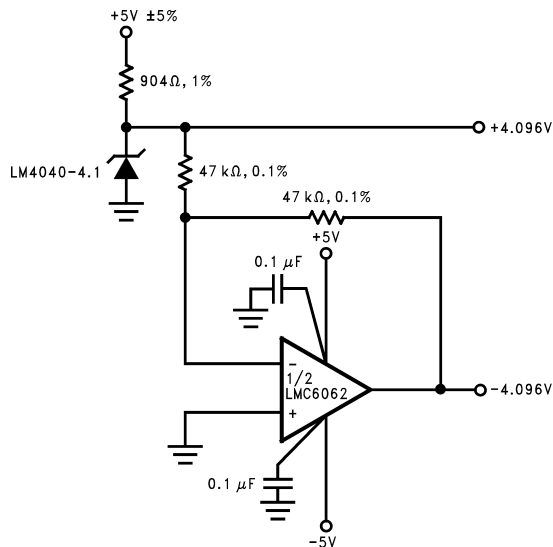

Figure 11. Precision ±4.096V Reference

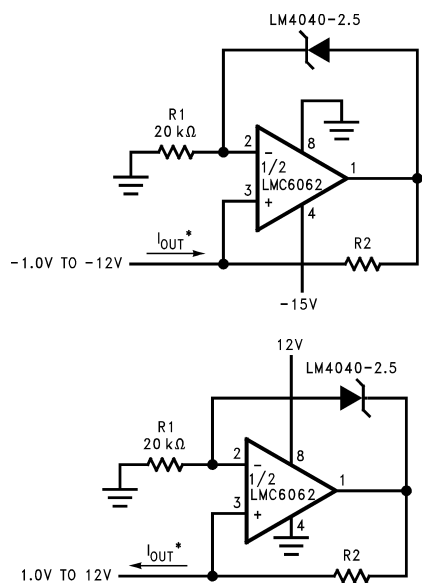

Figure 12. Precision 1 μA to 1 mA Current Sources

$$I_{OUT} = \frac{2.5V}{R_2}$$

(2)

PACKAGING INFORMATION

Orderable Device	Status (1)	Package Type	Package Drawing	Pins	Package Qty	Eco Plan (2)	Lead/Ball Finish	MSL Peak Temp (3)	Samples (Requires Login)
LM4040AIM3-10.0	ACTIVE	SOT-23	DBZ	3	1000	TBD	CU SNPB	Level-1-260C-UNLIM	
LM4040AIM3-10.0/NOPB	ACTIVE	SOT-23	DBZ	3	1000	Green (RoHS & no Sb/Br)	CU SN	Level-1-260C-UNLIM	
LM4040AIM3-2.0	ACTIVE	SOT-23	DBZ	3	1000	TBD	CU SNPB	Level-1-260C-UNLIM	
LM4040AIM3-2.0/NOPB	ACTIVE	SOT-23	DBZ	3	1000	Green (RoHS & no Sb/Br)	CU SN	Level-1-260C-UNLIM	
LM4040AIM3-2.5	ACTIVE	SOT-23	DBZ	3	1000	TBD	CU SNPB	Level-1-260C-UNLIM	
LM4040AIM3-2.5/NOPB	ACTIVE	SOT-23	DBZ	3	1000	Green (RoHS & no Sb/Br)	CU SN	Level-1-260C-UNLIM	
LM4040AIM3-3.0	ACTIVE	SOT-23	DBZ	3	1000	TBD	CU SNPB	Level-1-260C-UNLIM	
LM4040AIM3-3.0/NOPB	ACTIVE	SOT-23	DBZ	3	1000	Green (RoHS & no Sb/Br)	CU SN	Level-1-260C-UNLIM	
LM4040AIM3-4.1	ACTIVE	SOT-23	DBZ	3	1000	TBD	CU SNPB	Level-1-260C-UNLIM	
LM4040AIM3-4.1/NOPB	ACTIVE	SOT-23	DBZ	3	1000	Green (RoHS & no Sb/Br)	CU SN	Level-1-260C-UNLIM	
LM4040AIM3-5.0	ACTIVE	SOT-23	DBZ	3	1000	TBD	CU SNPB	Level-1-260C-UNLIM	
LM4040AIM3-5.0/NOPB	ACTIVE	SOT-23	DBZ	3	1000	Green (RoHS & no Sb/Br)	CU SN	Level-1-260C-UNLIM	
LM4040AIM3X-10	ACTIVE	SOT-23	DBZ	3	3000	TBD	CU SNPB	Level-1-260C-UNLIM	
LM4040AIM3X-10/NOPB	ACTIVE	SOT-23	DBZ	3	3000	Green (RoHS & no Sb/Br)	CU SN	Level-1-260C-UNLIM	
LM4040AIM3X-2.0/NOPB	ACTIVE	SOT-23	DBZ	3	3000	Green (RoHS & no Sb/Br)	CU SN	Level-1-260C-UNLIM	
LM4040AIM3X-2.5	ACTIVE	SOT-23	DBZ	3	3000	TBD	CU SNPB	Level-1-260C-UNLIM	
LM4040AIM3X-2.5/NOPB	ACTIVE	SOT-23	DBZ	3	3000	Green (RoHS & no Sb/Br)	CU SN	Level-1-260C-UNLIM	
LM4040AIM3X-3.0/NOPB	ACTIVE	SOT-23	DBZ	3	3000	Green (RoHS & no Sb/Br)	CU SN	Level-1-260C-UNLIM	
LM4040AIM3X-4.1/NOPB	ACTIVE	SOT-23	DBZ	3	3000	Green (RoHS & no Sb/Br)	CU SN	Level-1-260C-UNLIM	
LM4040AIM3X-5.0	ACTIVE	SOT-23	DBZ	3	3000	TBD	CU SNPB	Level-1-260C-UNLIM	
LM4040AIM3X-5.0/NOPB	ACTIVE	SOT-23	DBZ	3	3000	Green (RoHS & no Sb/Br)	CU SN	Level-1-260C-UNLIM	

Orderable Device	Status (1)	Package Type	Package Drawing	Pins	Package Qty	Eco Plan (2)	Lead/Ball Finish	MSL Peak Temp (3)	Samples (Requires Login)
LM4040AIZ-10.0/NOPB	ACTIVE	TO-92	LP	3	1800	Green (RoHS & no Sb/Br)	Call TI	Level-1-NA-UNLIM	
LM4040AIZ-2.5/NOPB	ACTIVE	TO-92	LP	3	1800	Green (RoHS & no Sb/Br)	Call TI	Level-1-NA-UNLIM	
LM4040AIZ-4.1/NOPB	ACTIVE	TO-92	LP	3	1800	Green (RoHS & no Sb/Br)	Call TI	Level-1-NA-UNLIM	
LM4040AIZ-5.0/NOPB	ACTIVE	TO-92	LP	3	1800	Green (RoHS & no Sb/Br)	Call TI	Level-1-NA-UNLIM	
LM4040BIM3-10.0	ACTIVE	SOT-23	DBZ	3	1000	TBD	CU SNPB	Level-1-260C-UNLIM	
LM4040BIM3-10.0/NOPB	ACTIVE	SOT-23	DBZ	3	1000	Green (RoHS & no Sb/Br)	CU SN	Level-1-260C-UNLIM	
LM4040BIM3-2.0/NOPB	ACTIVE	SOT-23	DBZ	3	1000	Green (RoHS & no Sb/Br)	CU SN	Level-1-260C-UNLIM	
LM4040BIM3-2.5	ACTIVE	SOT-23	DBZ	3	1000	TBD	CU SNPB	Level-1-260C-UNLIM	
LM4040BIM3-2.5/NOPB	ACTIVE	SOT-23	DBZ	3	1000	Green (RoHS & no Sb/Br)	CU SN	Level-1-260C-UNLIM	
LM4040BIM3-3.0	ACTIVE	SOT-23	DBZ	3	1000	TBD	CU SNPB	Level-1-260C-UNLIM	
LM4040BIM3-3.0/NOPB	ACTIVE	SOT-23	DBZ	3	1000	Green (RoHS & no Sb/Br)	CU SN	Level-1-260C-UNLIM	
LM4040BIM3-4.1	ACTIVE	SOT-23	DBZ	3	1000	TBD	CU SNPB	Level-1-260C-UNLIM	
LM4040BIM3-4.1/NOPB	ACTIVE	SOT-23	DBZ	3	1000	Green (RoHS & no Sb/Br)	CU SN	Level-1-260C-UNLIM	
LM4040BIM3-5.0	ACTIVE	SOT-23	DBZ	3	1000	TBD	CU SNPB	Level-1-260C-UNLIM	
LM4040BIM3-5.0/NOPB	ACTIVE	SOT-23	DBZ	3	1000	Green (RoHS & no Sb/Br)	CU SN	Level-1-260C-UNLIM	
LM4040BIM3-8.2	ACTIVE	SOT-23	DBZ	3	1000	TBD	CU SNPB	Level-1-260C-UNLIM	
LM4040BIM3-8.2/NOPB	ACTIVE	SOT-23	DBZ	3	1000	Green (RoHS & no Sb/Br)	CU SN	Level-1-260C-UNLIM	
LM4040BIM3X-10	ACTIVE	SOT-23	DBZ	3	3000	TBD	CU SNPB	Level-1-260C-UNLIM	
LM4040BIM3X-10/NOPB	ACTIVE	SOT-23	DBZ	3	3000	Green (RoHS & no Sb/Br)	CU SN	Level-1-260C-UNLIM	
LM4040BIM3X-2.0/NOPB	ACTIVE	SOT-23	DBZ	3	3000	Green (RoHS & no Sb/Br)	CU SN	Level-1-260C-UNLIM	
LM4040BIM3X-2.5	ACTIVE	SOT-23	DBZ	3	3000	TBD	CU SNPB	Level-1-260C-UNLIM	

Orderable Device	Status (1)	Package Type	Package Drawing	Pins	Package Qty	Eco Plan (2)	Lead/Ball Finish	MSL Peak Temp (3)	Samples (Requires Login)
LM4040BIM3X-2.5/NOPB	ACTIVE	SOT-23	DBZ	3	3000	Green (RoHS & no Sb/Br)	CU SN	Level-1-260C-UNLIM	
LM4040BIM3X-3.0/NOPB	ACTIVE	SOT-23	DBZ	3	3000	Green (RoHS & no Sb/Br)	CU SN	Level-1-260C-UNLIM	
LM4040BIM3X-4.1	ACTIVE	SOT-23	DBZ	3	3000	TBD	CU SNPB	Level-1-260C-UNLIM	
LM4040BIM3X-4.1/NOPB	ACTIVE	SOT-23	DBZ	3	3000	Green (RoHS & no Sb/Br)	CU SN	Level-1-260C-UNLIM	
LM4040BIM3X-5.0	ACTIVE	SOT-23	DBZ	3	3000	TBD	CU SNPB	Level-1-260C-UNLIM	
LM4040BIM3X-5.0/NOPB	ACTIVE	SOT-23	DBZ	3	3000	Green (RoHS & no Sb/Br)	CU SN	Level-1-260C-UNLIM	
LM4040BIM7-2.0/NOPB	ACTIVE	SC70	DCK	5	1000	Green (RoHS & no Sb/Br)	CU SN	Level-1-260C-UNLIM	
LM4040BIM7-2.5	ACTIVE	SC70	DCK	5	1000	TBD	CU SNPB	Level-1-260C-UNLIM	
LM4040BIM7-2.5/NOPB	ACTIVE	SC70	DCK	5	1000	Green (RoHS & no Sb/Br)	CU SN	Level-1-260C-UNLIM	
LM4040BIM7-5.0/NOPB	ACTIVE	SC70	DCK	5	1000	Green (RoHS & no Sb/Br)	CU SN	Level-1-260C-UNLIM	
LM4040BIM7X-2.5/NOPB	ACTIVE	SC70	DCK	5	3000	Green (RoHS & no Sb/Br)	CU SN	Level-1-260C-UNLIM	
LM4040BIZ-10.0/NOPB	ACTIVE	TO-92	LP	3	1800	Green (RoHS & no Sb/Br)	Call TI	Level-1-NA-UNLIM	
LM4040BIZ-2.5/NOPB	ACTIVE	TO-92	LP	3	1800	Green (RoHS & no Sb/Br)	Call TI	Level-1-NA-UNLIM	
LM4040BIZ-4.1/NOPB	ACTIVE	TO-92	LP	3	1800	Green (RoHS & no Sb/Br)	Call TI	Level-1-NA-UNLIM	
LM4040BIZ-5.0/NOPB	ACTIVE	TO-92	LP	3	1800	Green (RoHS & no Sb/Br)	Call TI	Level-1-NA-UNLIM	
LM4040CEM3-2.5	ACTIVE	SOT-23	DBZ	3	1000	TBD	CU SNPB	Level-1-260C-UNLIM	
LM4040CEM3-2.5/NOPB	ACTIVE	SOT-23	DBZ	3	1000	Green (RoHS & no Sb/Br)	CU SN	Level-1-260C-UNLIM	
LM4040CEM3-3.0/NOPB	ACTIVE	SOT-23	DBZ	3	1000	Green (RoHS & no Sb/Br)	CU SN	Level-1-260C-UNLIM	
LM4040CEM3-5.0	ACTIVE	SOT-23	DBZ	3	1000	TBD	CU SNPB	Level-1-260C-UNLIM	
LM4040CEM3-5.0/NOPB	ACTIVE	SOT-23	DBZ	3	1000	Green (RoHS & no Sb/Br)	CU SN	Level-1-260C-UNLIM	

Orderable Device	Status (1)	Package Type	Package Drawing	Pins	Package Qty	Eco Plan (2)	Lead/Ball Finish	MSL Peak Temp (3)	Samples (Requires Login)
LM4040CEM3X-3.0/NOPB	ACTIVE	SOT-23	DBZ	3	3000	Green (RoHS & no Sb/Br)	CU SN	Level-1-260C-UNLIM	
LM4040CEM3X-5.0	ACTIVE	SOT-23	DBZ	3	3000	TBD	CU SNPB	Level-1-260C-UNLIM	
LM4040CEM3X-5.0/NOPB	ACTIVE	SOT-23	DBZ	3	3000	Green (RoHS & no Sb/Br)	CU SN	Level-1-260C-UNLIM	
LM4040CIM3-10.0	ACTIVE	SOT-23	DBZ	3	1000	TBD	CU SNPB	Level-1-260C-UNLIM	
LM4040CIM3-10.0/NOPB	ACTIVE	SOT-23	DBZ	3	1000	Green (RoHS & no Sb/Br)	CU SN	Level-1-260C-UNLIM	
LM4040CIM3-2.0	ACTIVE	SOT-23	DBZ	3	1000	TBD	CU SNPB	Level-1-260C-UNLIM	
LM4040CIM3-2.0/NOPB	ACTIVE	SOT-23	DBZ	3	1000	Green (RoHS & no Sb/Br)	CU SN	Level-1-260C-UNLIM	
LM4040CIM3-2.5	ACTIVE	SOT-23	DBZ	3	1000	TBD	CU SNPB	Level-1-260C-UNLIM	
LM4040CIM3-2.5/NOPB	ACTIVE	SOT-23	DBZ	3	1000	Green (RoHS & no Sb/Br)	CU SN	Level-1-260C-UNLIM	
LM4040CIM3-3.0	ACTIVE	SOT-23	DBZ	3	1000	TBD	CU SNPB	Level-1-260C-UNLIM	
LM4040CIM3-3.0/NOPB	ACTIVE	SOT-23	DBZ	3	1000	Green (RoHS & no Sb/Br)	CU SN	Level-1-260C-UNLIM	
LM4040CIM3-4.1	ACTIVE	SOT-23	DBZ	3	1000	TBD	CU SNPB	Level-1-260C-UNLIM	
LM4040CIM3-4.1/NOPB	ACTIVE	SOT-23	DBZ	3	1000	Green (RoHS & no Sb/Br)	CU SN	Level-1-260C-UNLIM	
LM4040CIM3-5.0	ACTIVE	SOT-23	DBZ	3	1000	TBD	CU SNPB	Level-1-260C-UNLIM	
LM4040CIM3-5.0/NOPB	ACTIVE	SOT-23	DBZ	3	1000	Green (RoHS & no Sb/Br)	CU SN	Level-1-260C-UNLIM	
LM4040CIM3-8.2	ACTIVE	SOT-23	DBZ	3	1000	TBD	CU SNPB	Level-1-260C-UNLIM	
LM4040CIM3-8.2/NOPB	ACTIVE	SOT-23	DBZ	3	1000	Green (RoHS & no Sb/Br)	CU SN	Level-1-260C-UNLIM	
LM4040CIM3X-10	ACTIVE	SOT-23	DBZ	3	3000	TBD	CU SNPB	Level-1-260C-UNLIM	
LM4040CIM3X-10/NOPB	ACTIVE	SOT-23	DBZ	3	3000	Green (RoHS & no Sb/Br)	CU SN	Level-1-260C-UNLIM	
LM4040CIM3X-2.0/NOPB	ACTIVE	SOT-23	DBZ	3	3000	Green (RoHS & no Sb/Br)	CU SN	Level-1-260C-UNLIM	
LM4040CIM3X-2.5	ACTIVE	SOT-23	DBZ	3	3000	TBD	CU SNPB	Level-1-260C-UNLIM	
LM4040CIM3X-2.5/NOPB	ACTIVE	SOT-23	DBZ	3	3000	Green (RoHS & no Sb/Br)	CU SN	Level-1-260C-UNLIM	

Orderable Device	Status (1)	Package Type	Package Drawing	Pins	Package Qty	Eco Plan (2)	Lead/Ball Finish	MSL Peak Temp (3)	Samples (Requires Login)
LM4040CIM3X-3.0	ACTIVE	SOT-23	DBZ	3	3000	TBD	CU SNPB	Level-1-260C-UNLIM	
LM4040CIM3X-3.0/NOPB	ACTIVE	SOT-23	DBZ	3	3000	Green (RoHS & no Sb/Br)	CU SN	Level-1-260C-UNLIM	
LM4040CIM3X-4.1	ACTIVE	SOT-23	DBZ	3	3000	TBD	CU SNPB	Level-1-260C-UNLIM	
LM4040CIM3X-4.1/NOPB	ACTIVE	SOT-23	DBZ	3	3000	Green (RoHS & no Sb/Br)	CU SN	Level-1-260C-UNLIM	
LM4040CIM3X-5.0	ACTIVE	SOT-23	DBZ	3	3000	TBD	CU SNPB	Level-1-260C-UNLIM	
LM4040CIM3X-5.0/NOPB	ACTIVE	SOT-23	DBZ	3	3000	Green (RoHS & no Sb/Br)	CU SN	Level-1-260C-UNLIM	
LM4040CIM7-2.0/NOPB	ACTIVE	SC70	DCK	5	1000	Green (RoHS & no Sb/Br)	CU SN	Level-1-260C-UNLIM	
LM4040CIM7-2.5/NOPB	ACTIVE	SC70	DCK	5	1000	Green (RoHS & no Sb/Br)	CU SN	Level-1-260C-UNLIM	
LM4040CIM7X-2.5/NOPB	ACTIVE	SC70	DCK	5	3000	Green (RoHS & no Sb/Br)	CU SN	Level-1-260C-UNLIM	
LM4040CIZ-10.0/NOPB	ACTIVE	TO-92	LP	3	1800	Green (RoHS & no Sb/Br)	Call TI	Level-1-NA-UNLIM	
LM4040CIZ-2.5/LFT8	ACTIVE	TO-92	LP	3	2000	Green (RoHS & no Sb/Br)	Call TI	Level-1-NA-UNLIM	
LM4040CIZ-2.5/NOPB	ACTIVE	TO-92	LP	3	1800	Green (RoHS & no Sb/Br)	Call TI	Level-1-NA-UNLIM	
LM4040CIZ-4.1/NOPB	ACTIVE	TO-92	LP	3	1800	Green (RoHS & no Sb/Br)	Call TI	Level-1-NA-UNLIM	
LM4040CIZ-5.0/NOPB	ACTIVE	TO-92	LP	3	1800	Green (RoHS & no Sb/Br)	Call TI	Level-1-NA-UNLIM	
LM4040DEM3-2.0	ACTIVE	SOT-23	DBZ	3	1000	TBD	CU SNPB	Level-1-260C-UNLIM	
LM4040DEM3-2.0/NOPB	ACTIVE	SOT-23	DBZ	3	1000	Green (RoHS & no Sb/Br)	CU SN	Level-1-260C-UNLIM	
LM4040DEM3-2.5/NOPB	ACTIVE	SOT-23	DBZ	3	1000	Green (RoHS & no Sb/Br)	CU SN	Level-1-260C-UNLIM	
LM4040DEM3-3.0/NOPB	ACTIVE	SOT-23	DBZ	3	1000	Green (RoHS & no Sb/Br)	CU SN	Level-1-260C-UNLIM	
LM4040DEM3-5.0	ACTIVE	SOT-23	DBZ	3	1000	TBD	CU SNPB	Level-1-260C-UNLIM	
LM4040DEM3-5.0/NOPB	ACTIVE	SOT-23	DBZ	3	1000	Green (RoHS & no Sb/Br)	CU SN	Level-1-260C-UNLIM	

Orderable Device	Status (1)	Package Type	Package Drawing	Pins	Package Qty	Eco Plan (2)	Lead/Ball Finish	MSL Peak Temp (3)	Samples (Requires Login)
LM4040DEM3X-2.5/NOPB	ACTIVE	SOT-23	DBZ	3	3000	Green (RoHS & no Sb/Br)	CU SN	Level-1-260C-UNLIM	
LM4040DEM3X-5.0	ACTIVE	SOT-23	DBZ	3	3000	TBD	CU SNPB	Level-1-260C-UNLIM	
LM4040DEM3X-5.0/NOPB	ACTIVE	SOT-23	DBZ	3	3000	Green (RoHS & no Sb/Br)	CU SN	Level-1-260C-UNLIM	
LM4040DIM3-10.0	ACTIVE	SOT-23	DBZ	3	1000	TBD	CU SNPB	Level-1-260C-UNLIM	
LM4040DIM3-10.0/NOPB	ACTIVE	SOT-23	DBZ	3	1000	Green (RoHS & no Sb/Br)	CU SN	Level-1-260C-UNLIM	
LM4040DIM3-2.0/NOPB	ACTIVE	SOT-23	DBZ	3	1000	Green (RoHS & no Sb/Br)	CU SN	Level-1-260C-UNLIM	
LM4040DIM3-2.5	ACTIVE	SOT-23	DBZ	3	1000	TBD	CU SNPB	Level-1-260C-UNLIM	
LM4040DIM3-2.5/NOPB	ACTIVE	SOT-23	DBZ	3	1000	Green (RoHS & no Sb/Br)	CU SN	Level-1-260C-UNLIM	
LM4040DIM3-3.0	ACTIVE	SOT-23	DBZ	3	1000	TBD	CU SNPB	Level-1-260C-UNLIM	
LM4040DIM3-3.0/NOPB	ACTIVE	SOT-23	DBZ	3	1000	Green (RoHS & no Sb/Br)	CU SN	Level-1-260C-UNLIM	
LM4040DIM3-4.1	ACTIVE	SOT-23	DBZ	3	1000	TBD	CU SNPB	Level-1-260C-UNLIM	
LM4040DIM3-4.1/NOPB	ACTIVE	SOT-23	DBZ	3	1000	Green (RoHS & no Sb/Br)	CU SN	Level-1-260C-UNLIM	
LM4040DIM3-5.0	ACTIVE	SOT-23	DBZ	3	1000	TBD	CU SNPB	Level-1-260C-UNLIM	
LM4040DIM3-5.0/NOPB	ACTIVE	SOT-23	DBZ	3	1000	Green (RoHS & no Sb/Br)	CU SN	Level-1-260C-UNLIM	
LM4040DIM3-8.2/NOPB	ACTIVE	SOT-23	DBZ	3	1000	Green (RoHS & no Sb/Br)	CU SN	Level-1-260C-UNLIM	
LM4040DIM3X-10	ACTIVE	SOT-23	DBZ	3	3000	TBD	CU SNPB	Level-1-260C-UNLIM	
LM4040DIM3X-10/NOPB	ACTIVE	SOT-23	DBZ	3	3000	Green (RoHS & no Sb/Br)	CU SN	Level-1-260C-UNLIM	
LM4040DIM3X-2.0/NOPB	ACTIVE	SOT-23	DBZ	3	3000	Green (RoHS & no Sb/Br)	CU SN	Level-1-260C-UNLIM	
LM4040DIM3X-2.5	ACTIVE	SOT-23	DBZ	3	3000	TBD	CU SNPB	Level-1-260C-UNLIM	
LM4040DIM3X-2.5/NOPB	ACTIVE	SOT-23	DBZ	3	3000	Green (RoHS & no Sb/Br)	CU SN	Level-1-260C-UNLIM	
LM4040DIM3X-3.0/NOPB	ACTIVE	SOT-23	DBZ	3	3000	Green (RoHS & no Sb/Br)	CU SN	Level-1-260C-UNLIM	
LM4040DIM3X-4.1	ACTIVE	SOT-23	DBZ	3	3000	TBD	CU SNPB	Level-1-260C-UNLIM	

Orderable Device	Status (1)	Package Type	Package Drawing	Pins	Package Qty	Eco Plan (2)	Lead/Ball Finish	MSL Peak Temp (3)	Samples (Requires Login)
LM4040DIM3X-4.1/NOPB	ACTIVE	SOT-23	DBZ	3	3000	Green (RoHS & no Sb/Br)	CU SN	Level-1-260C-UNLIM	
LM4040DIM3X-5.0	ACTIVE	SOT-23	DBZ	3	3000	TBD	CU SNPB	Level-1-260C-UNLIM	
LM4040DIM3X-5.0/NOPB	ACTIVE	SOT-23	DBZ	3	3000	Green (RoHS & no Sb/Br)	CU SN	Level-1-260C-UNLIM	
LM4040DIM7-2.0/NOPB	ACTIVE	SC70	DCK	5	1000	Green (RoHS & no Sb/Br)	CU SN	Level-1-260C-UNLIM	
LM4040DIM7-2.5/NOPB	ACTIVE	SC70	DCK	5	1000	Green (RoHS & no Sb/Br)	CU SN	Level-1-260C-UNLIM	
LM4040DIM7-5.0	ACTIVE	SC70	DCK	5	1000	TBD	CU SNPB	Level-1-260C-UNLIM	
LM4040DIM7-5.0/NOPB	ACTIVE	SC70	DCK	5	1000	Green (RoHS & no Sb/Br)	CU SN	Level-1-260C-UNLIM	
LM4040DIZ-10.0/NOPB	ACTIVE	TO-92	LP	3	1800	Green (RoHS & no Sb/Br)	Call TI	Level-1-NA-UNLIM	
LM4040DIZ-2.5/NOPB	ACTIVE	TO-92	LP	3	1800	Green (RoHS & no Sb/Br)	Call TI	Level-1-NA-UNLIM	
LM4040DIZ-4.1/NOPB	ACTIVE	TO-92	LP	3	1800	Green (RoHS & no Sb/Br)	Call TI	Level-1-NA-UNLIM	
LM4040DIZ-5.0/LFT1	ACTIVE	TO-92	LP	3	2000	Green (RoHS & no Sb/Br)	Call TI	Level-1-NA-UNLIM	
LM4040DIZ-5.0/NOPB	ACTIVE	TO-92	LP	3	1800	Green (RoHS & no Sb/Br)	Call TI	Level-1-NA-UNLIM	
LM4040EEM3-2.5/NOPB	ACTIVE	SOT-23	DBZ	3	1000	Green (RoHS & no Sb/Br)	CU SN	Level-1-260C-UNLIM	
LM4040EEM3-3.0/NOPB	ACTIVE	SOT-23	DBZ	3	1000	Green (RoHS & no Sb/Br)	CU SN	Level-1-260C-UNLIM	
LM4040EIM3-2.5	ACTIVE	SOT-23	DBZ	3	1000	TBD	CU SNPB	Level-1-260C-UNLIM	
LM4040EIM3-2.5/NOPB	ACTIVE	SOT-23	DBZ	3	1000	Green (RoHS & no Sb/Br)	CU SN	Level-1-260C-UNLIM	
LM4040EIM3-3.0/NOPB	ACTIVE	SOT-23	DBZ	3	1000	Green (RoHS & no Sb/Br)	CU SN	Level-1-260C-UNLIM	
LM4040EIM3X-2.5	ACTIVE	SOT-23	DBZ	3	3000	TBD	CU SNPB	Level-1-260C-UNLIM	
LM4040EIM3X-2.5/NOPB	ACTIVE	SOT-23	DBZ	3	3000	Green (RoHS & no Sb/Br)	CU SN	Level-1-260C-UNLIM	

Orderable Device	Status (1)	Package Type	Package Drawing	Pins	Package Qty	Eco Plan (2)	Lead/Ball Finish	MSL Peak Temp (3)	Samples (Requires Login)
LM4040EIM3X-3.0/NOPB	ACTIVE	SOT-23	DBZ	3	3000	Green (RoHS & no Sb/Br)	CU SN	Level-1-260C-UNLIM	
LM4040EIM7-2.0/NOPB	ACTIVE	SC70	DCK	5	1000	Green (RoHS & no Sb/Br)	CU SN	Level-1-260C-UNLIM	
LM4040QAIM3-2.5/NOPB	ACTIVE	SOT-23	DBZ	3	1000	Green (RoHS & no Sb/Br)	CU SN	Level-1-260C-UNLIM	
LM4040QAIM3X2.5/NOPB	ACTIVE	SOT-23	DBZ	3	3000	Green (RoHS & no Sb/Br)	CU SN	Level-1-260C-UNLIM	
LM4040QBIM3-2.5/NOPB	ACTIVE	SOT-23	DBZ	3	1000	Green (RoHS & no Sb/Br)	CU SN	Level-1-260C-UNLIM	
LM4040QBIM3X2.5/NOPB	ACTIVE	SOT-23	DBZ	3	3000	Green (RoHS & no Sb/Br)	CU SN	Level-1-260C-UNLIM	
LM4040QCEM3-2.5/NOPB	ACTIVE	SOT-23	DBZ	3	1000	Green (RoHS & no Sb/Br)	CU SN	Level-1-260C-UNLIM	
LM4040QCIM3-2.5/NOPB	ACTIVE	SOT-23	DBZ	3	1000	Green (RoHS & no Sb/Br)	CU SN	Level-1-260C-UNLIM	
LM4040QCIM3X2.5/NOPB	ACTIVE	SOT-23	DBZ	3	3000	Green (RoHS & no Sb/Br)	CU SN	Level-1-260C-UNLIM	
LM4040QDEM3-2.5/NOPB	ACTIVE	SOT-23	DBZ	3	1000	Green (RoHS & no Sb/Br)	CU SN	Level-1-260C-UNLIM	
LM4040QDIM3-2.5/NOPB	ACTIVE	SOT-23	DBZ	3	1000	Green (RoHS & no Sb/Br)	CU SN	Level-1-260C-UNLIM	
LM4040QDIM3X2.5/NOPB	ACTIVE	SOT-23	DBZ	3	3000	Green (RoHS & no Sb/Br)	CU SN	Level-1-260C-UNLIM	
LM4040QEEM3-2.5/NOPB	ACTIVE	SOT-23	DBZ	3	1000	Green (RoHS & no Sb/Br)	CU SN	Level-1-260C-UNLIM	
LM4040QEIM3-2.5/NOPB	ACTIVE	SOT-23	DBZ	3	1000	Green (RoHS & no Sb/Br)	CU SN	Level-1-260C-UNLIM	
LM4040QEIM3X2.5/NOPB	ACTIVE	SOT-23	DBZ	3	3000	Green (RoHS & no Sb/Br)	CU SN	Level-1-260C-UNLIM	

(1) The marketing status values are defined as follows:

ACTIVE: Product device recommended for new designs.

LIFEBUY: TI has announced that the device will be discontinued, and a lifetime-buy period is in effect.

NRND: Not recommended for new designs. Device is in production to support existing customers, but TI does not recommend using this part in a new design.

PREVIEW: Device has been announced but is not in production. Samples may or may not be available.

OBSOLETE: TI has discontinued the production of the device.

⁽²⁾ Eco Plan - The planned eco-friendly classification: Pb-Free (RoHS), Pb-Free (RoHS Exempt), or Green (RoHS & no Sb/Br) - please check <http://www.ti.com/productcontent> for the latest availability information and additional product content details.

TBD: The Pb-Free/Green conversion plan has not been defined.

Pb-Free (RoHS): TI's terms "Lead-Free" or "Pb-Free" mean semiconductor products that are compatible with the current RoHS requirements for all 6 substances, including the requirement that lead not exceed 0.1% by weight in homogeneous materials. Where designed to be soldered at high temperatures, TI Pb-Free products are suitable for use in specified lead-free processes.

Pb-Free (RoHS Exempt): This component has a RoHS exemption for either 1) lead-based flip-chip solder bumps used between the die and package, or 2) lead-based die adhesive used between the die and leadframe. The component is otherwise considered Pb-Free (RoHS compatible) as defined above.

Green (RoHS & no Sb/Br): TI defines "Green" to mean Pb-Free (RoHS compatible), and free of Bromine (Br) and Antimony (Sb) based flame retardants (Br or Sb do not exceed 0.1% by weight in homogeneous material)

⁽³⁾ MSL, Peak Temp. -- The Moisture Sensitivity Level rating according to the JEDEC industry standard classifications, and peak solder temperature.

Important Information and Disclaimer: The information provided on this page represents TI's knowledge and belief as of the date that it is provided. TI bases its knowledge and belief on information provided by third parties, and makes no representation or warranty as to the accuracy of such information. Efforts are underway to better integrate information from third parties. TI has taken and continues to take reasonable steps to provide representative and accurate information but may not have conducted destructive testing or chemical analysis on incoming materials and chemicals. TI and TI suppliers consider certain information to be proprietary, and thus CAS numbers and other limited information may not be available for release.

In no event shall TI's liability arising out of such information exceed the total purchase price of the TI part(s) at issue in this document sold by TI to Customer on an annual basis.

OTHER QUALIFIED VERSIONS OF LM4040-N, LM4040-N-Q1 :

- Catalog: [LM4040-N](#)
- Automotive: [LM4040-N-Q1](#)

NOTE: Qualified Version Definitions:

- Catalog - TI's standard catalog product
- Automotive - Q100 devices qualified for high-reliability automotive applications targeting zero defects

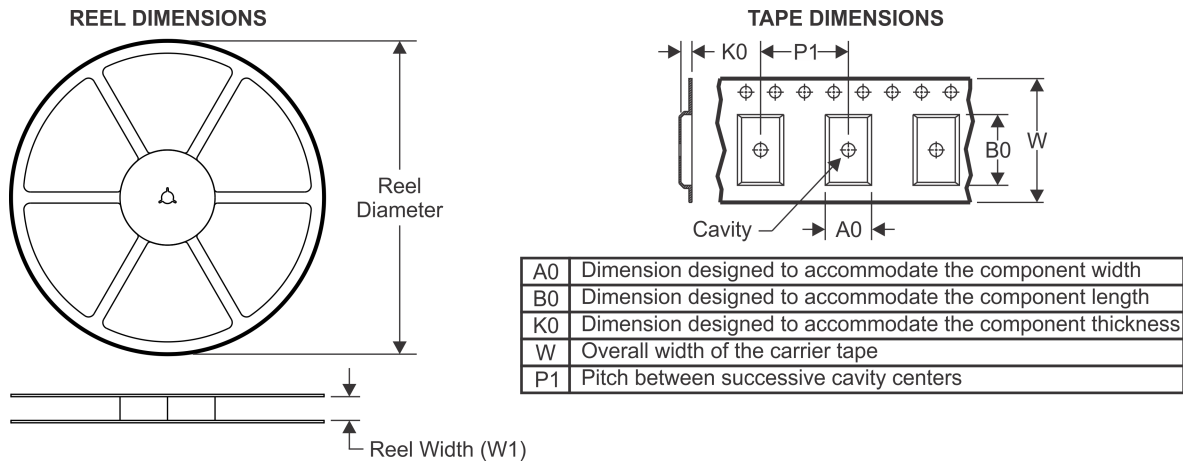
TAPE AND REEL INFORMATION

QUADRANT ASSIGNMENTS FOR PIN 1 ORIENTATION IN TAPE



*All dimensions are nominal

Device	Package Type	Package Drawing	Pins	SPQ	Reel Diameter (mm)	Reel Width W1 (mm)	A0 (mm)	B0 (mm)	K0 (mm)	P1 (mm)	W (mm)	Pin1 Quadrant
LM4040AIM3-10.0	SOT-23	DBZ	3	1000	178.0	8.4	3.3	2.9	1.22	4.0	8.0	Q3
LM4040AIM3-10.0/NOPB	SOT-23	DBZ	3	1000	178.0	8.4	3.3	2.9	1.22	4.0	8.0	Q3
LM4040AIM3-2.0	SOT-23	DBZ	3	1000	178.0	8.4	3.3	2.9	1.22	4.0	8.0	Q3
LM4040AIM3-2.0/NOPB	SOT-23	DBZ	3	1000	178.0	8.4	3.3	2.9	1.22	4.0	8.0	Q3
LM4040AIM3-2.5	SOT-23	DBZ	3	1000	178.0	8.4	3.3	2.9	1.22	4.0	8.0	Q3
LM4040AIM3-2.5/NOPB	SOT-23	DBZ	3	1000	178.0	8.4	3.3	2.9	1.22	4.0	8.0	Q3
LM4040AIM3-3.0	SOT-23	DBZ	3	1000	178.0	8.4	3.3	2.9	1.22	4.0	8.0	Q3
LM4040AIM3-3.0/NOPB	SOT-23	DBZ	3	1000	178.0	8.4	3.3	2.9	1.22	4.0	8.0	Q3
LM4040AIM3-4.1	SOT-23	DBZ	3	1000	178.0	8.4	3.3	2.9	1.22	4.0	8.0	Q3
LM4040AIM3-4.1/NOPB	SOT-23	DBZ	3	1000	178.0	8.4	3.3	2.9	1.22	4.0	8.0	Q3
LM4040AIM3-5.0	SOT-23	DBZ	3	1000	178.0	8.4	3.3	2.9	1.22	4.0	8.0	Q3
LM4040AIM3-5.0/NOPB	SOT-23	DBZ	3	1000	178.0	8.4	3.3	2.9	1.22	4.0	8.0	Q3
LM4040AIM3X-10	SOT-23	DBZ	3	3000	178.0	8.4	3.3	2.9	1.22	4.0	8.0	Q3
LM4040AIM3X-10/NOPB	SOT-23	DBZ	3	3000	178.0	8.4	3.3	2.9	1.22	4.0	8.0	Q3
LM4040AIM3X-2.0/NOPB	SOT-23	DBZ	3	3000	178.0	8.4	3.3	2.9	1.22	4.0	8.0	Q3
LM4040AIM3X-2.5	SOT-23	DBZ	3	3000	178.0	8.4	3.3	2.9	1.22	4.0	8.0	Q3
LM4040AIM3X-2.5/NOPB	SOT-23	DBZ	3	3000	178.0	8.4	3.3	2.9	1.22	4.0	8.0	Q3
LM4040AIM3X-3.0/NOPB	SOT-23	DBZ	3	3000	178.0	8.4	3.3	2.9	1.22	4.0	8.0	Q3

Device	Package Type	Package Drawing	Pins	SPQ	Reel Diameter (mm)	Reel Width W1 (mm)	A0 (mm)	B0 (mm)	K0 (mm)	P1 (mm)	W (mm)	Pin1 Quadrant
LM4040AIM3X-4.1/NOPB	SOT-23	DBZ	3	3000	178.0	8.4	3.3	2.9	1.22	4.0	8.0	Q3
LM4040AIM3X-5.0	SOT-23	DBZ	3	3000	178.0	8.4	3.3	2.9	1.22	4.0	8.0	Q3
LM4040AIM3X-5.0/NOPB	SOT-23	DBZ	3	3000	178.0	8.4	3.3	2.9	1.22	4.0	8.0	Q3
LM4040BIM3-10.0	SOT-23	DBZ	3	1000	178.0	8.4	3.3	2.9	1.22	4.0	8.0	Q3
LM4040BIM3-10.0/NOPB	SOT-23	DBZ	3	1000	178.0	8.4	3.3	2.9	1.22	4.0	8.0	Q3
LM4040BIM3-2.0/NOPB	SOT-23	DBZ	3	1000	178.0	8.4	3.3	2.9	1.22	4.0	8.0	Q3
LM4040BIM3-2.5	SOT-23	DBZ	3	1000	178.0	8.4	3.3	2.9	1.22	4.0	8.0	Q3
LM4040BIM3-2.5/NOPB	SOT-23	DBZ	3	1000	178.0	8.4	3.3	2.9	1.22	4.0	8.0	Q3
LM4040BIM3-3.0	SOT-23	DBZ	3	1000	178.0	8.4	3.3	2.9	1.22	4.0	8.0	Q3
LM4040BIM3-3.0/NOPB	SOT-23	DBZ	3	1000	178.0	8.4	3.3	2.9	1.22	4.0	8.0	Q3
LM4040BIM3-4.1	SOT-23	DBZ	3	1000	178.0	8.4	3.3	2.9	1.22	4.0	8.0	Q3
LM4040BIM3-4.1/NOPB	SOT-23	DBZ	3	1000	178.0	8.4	3.3	2.9	1.22	4.0	8.0	Q3
LM4040BIM3-5.0	SOT-23	DBZ	3	1000	178.0	8.4	3.3	2.9	1.22	4.0	8.0	Q3
LM4040BIM3-5.0/NOPB	SOT-23	DBZ	3	1000	178.0	8.4	3.3	2.9	1.22	4.0	8.0	Q3
LM4040BIM3-8.2	SOT-23	DBZ	3	1000	178.0	8.4	3.3	2.9	1.22	4.0	8.0	Q3
LM4040BIM3-8.2/NOPB	SOT-23	DBZ	3	1000	178.0	8.4	3.3	2.9	1.22	4.0	8.0	Q3
LM4040BIM3X-10	SOT-23	DBZ	3	3000	178.0	8.4	3.3	2.9	1.22	4.0	8.0	Q3
LM4040BIM3X-10/NOPB	SOT-23	DBZ	3	3000	178.0	8.4	3.3	2.9	1.22	4.0	8.0	Q3
LM4040BIM3X-2.0/NOPB	SOT-23	DBZ	3	3000	178.0	8.4	3.3	2.9	1.22	4.0	8.0	Q3
LM4040BIM3X-2.5	SOT-23	DBZ	3	3000	178.0	8.4	3.3	2.9	1.22	4.0	8.0	Q3
LM4040BIM3X-2.5/NOPB	SOT-23	DBZ	3	3000	178.0	8.4	3.3	2.9	1.22	4.0	8.0	Q3
LM4040BIM3X-3.0/NOPB	SOT-23	DBZ	3	3000	178.0	8.4	3.3	2.9	1.22	4.0	8.0	Q3
LM4040BIM3X-4.1	SOT-23	DBZ	3	3000	178.0	8.4	3.3	2.9	1.22	4.0	8.0	Q3
LM4040BIM3X-4.1/NOPB	SOT-23	DBZ	3	3000	178.0	8.4	3.3	2.9	1.22	4.0	8.0	Q3
LM4040BIM3X-5.0	SOT-23	DBZ	3	3000	178.0	8.4	3.3	2.9	1.22	4.0	8.0	Q3
LM4040BIM3X-5.0/NOPB	SOT-23	DBZ	3	3000	178.0	8.4	3.3	2.9	1.22	4.0	8.0	Q3
LM4040BIM7-2.0/NOPB	SC70	DCK	5	1000	178.0	8.4	2.25	2.45	1.2	4.0	8.0	Q3
LM4040BIM7-2.5	SC70	DCK	5	1000	178.0	8.4	2.25	2.45	1.2	4.0	8.0	Q3
LM4040BIM7-2.5/NOPB	SC70	DCK	5	1000	178.0	8.4	2.25	2.45	1.2	4.0	8.0	Q3
LM4040BIM7-5.0/NOPB	SC70	DCK	5	1000	178.0	8.4	2.25	2.45	1.2	4.0	8.0	Q3
LM4040BIM7X-2.5/NOPB	SC70	DCK	5	3000	178.0	8.4	2.25	2.45	1.2	4.0	8.0	Q3
LM4040CEM3-2.5	SOT-23	DBZ	3	1000	178.0	8.4	3.3	2.9	1.22	4.0	8.0	Q3
LM4040CEM3-2.5/NOPB	SOT-23	DBZ	3	1000	178.0	8.4	3.3	2.9	1.22	4.0	8.0	Q3
LM4040CEM3-3.0/NOPB	SOT-23	DBZ	3	1000	178.0	8.4	3.3	2.9	1.22	4.0	8.0	Q3
LM4040CEM3-5.0	SOT-23	DBZ	3	1000	178.0	8.4	3.3	2.9	1.22	4.0	8.0	Q3
LM4040CEM3-5.0/NOPB	SOT-23	DBZ	3	1000	178.0	8.4	3.3	2.9	1.22	4.0	8.0	Q3
LM4040CEM3X-3.0/NOPB	SOT-23	DBZ	3	3000	178.0	8.4	3.3	2.9	1.22	4.0	8.0	Q3
LM4040CEM3X-5.0	SOT-23	DBZ	3	3000	178.0	8.4	3.3	2.9	1.22	4.0	8.0	Q3
LM4040CEM3X-5.0/NOPB	SOT-23	DBZ	3	3000	178.0	8.4	3.3	2.9	1.22	4.0	8.0	Q3
LM4040CIM3-10.0	SOT-23	DBZ	3	1000	178.0	8.4	3.3	2.9	1.22	4.0	8.0	Q3
LM4040CIM3-10.0/NOPB	SOT-23	DBZ	3	1000	178.0	8.4	3.3	2.9	1.22	4.0	8.0	Q3
LM4040CIM3-2.0	SOT-23	DBZ	3	1000	178.0	8.4	3.3	2.9	1.22	4.0	8.0	Q3
LM4040CIM3-2.0/NOPB	SOT-23	DBZ	3	1000	178.0	8.4	3.3	2.9	1.22	4.0	8.0	Q3

Device	Package Type	Package Drawing	Pins	SPQ	Reel Diameter (mm)	Reel Width W1 (mm)	A0 (mm)	B0 (mm)	K0 (mm)	P1 (mm)	W (mm)	Pin1 Quadrant
LM4040CIM3-2.5	SOT-23	DBZ	3	1000	178.0	8.4	3.3	2.9	1.22	4.0	8.0	Q3
LM4040CIM3-2.5/NOPB	SOT-23	DBZ	3	1000	178.0	8.4	3.3	2.9	1.22	4.0	8.0	Q3
LM4040CIM3-3.0	SOT-23	DBZ	3	1000	178.0	8.4	3.3	2.9	1.22	4.0	8.0	Q3
LM4040CIM3-3.0/NOPB	SOT-23	DBZ	3	1000	178.0	8.4	3.3	2.9	1.22	4.0	8.0	Q3
LM4040CIM3-4.1	SOT-23	DBZ	3	1000	178.0	8.4	3.3	2.9	1.22	4.0	8.0	Q3
LM4040CIM3-4.1/NOPB	SOT-23	DBZ	3	1000	178.0	8.4	3.3	2.9	1.22	4.0	8.0	Q3
LM4040CIM3-5.0	SOT-23	DBZ	3	1000	178.0	8.4	3.3	2.9	1.22	4.0	8.0	Q3
LM4040CIM3-5.0/NOPB	SOT-23	DBZ	3	1000	178.0	8.4	3.3	2.9	1.22	4.0	8.0	Q3
LM4040CIM3-8.2	SOT-23	DBZ	3	1000	178.0	8.4	3.3	2.9	1.22	4.0	8.0	Q3
LM4040CIM3-8.2/NOPB	SOT-23	DBZ	3	1000	178.0	8.4	3.3	2.9	1.22	4.0	8.0	Q3
LM4040CIM3X-10	SOT-23	DBZ	3	3000	178.0	8.4	3.3	2.9	1.22	4.0	8.0	Q3
LM4040CIM3X-10/NOPB	SOT-23	DBZ	3	3000	178.0	8.4	3.3	2.9	1.22	4.0	8.0	Q3
LM4040CIM3X-2.0/NOPB	SOT-23	DBZ	3	3000	178.0	8.4	3.3	2.9	1.22	4.0	8.0	Q3
LM4040CIM3X-2.5	SOT-23	DBZ	3	3000	178.0	8.4	3.3	2.9	1.22	4.0	8.0	Q3
LM4040CIM3X-2.5/NOPB	SOT-23	DBZ	3	3000	178.0	8.4	3.3	2.9	1.22	4.0	8.0	Q3
LM4040CIM3X-3.0	SOT-23	DBZ	3	3000	178.0	8.4	3.3	2.9	1.22	4.0	8.0	Q3
LM4040CIM3X-3.0/NOPB	SOT-23	DBZ	3	3000	178.0	8.4	3.3	2.9	1.22	4.0	8.0	Q3
LM4040CIM3X-4.1	SOT-23	DBZ	3	3000	178.0	8.4	3.3	2.9	1.22	4.0	8.0	Q3
LM4040CIM3X-4.1/NOPB	SOT-23	DBZ	3	3000	178.0	8.4	3.3	2.9	1.22	4.0	8.0	Q3
LM4040CIM3X-5.0	SOT-23	DBZ	3	3000	178.0	8.4	3.3	2.9	1.22	4.0	8.0	Q3
LM4040CIM3X-5.0/NOPB	SOT-23	DBZ	3	3000	178.0	8.4	3.3	2.9	1.22	4.0	8.0	Q3
LM4040CIM7-2.0/NOPB	SC70	DCK	5	1000	178.0	8.4	2.25	2.45	1.2	4.0	8.0	Q3
LM4040CIM7-2.5/NOPB	SC70	DCK	5	1000	178.0	8.4	2.25	2.45	1.2	4.0	8.0	Q3
LM4040CIM7X-2.5/NOPB	SC70	DCK	5	3000	178.0	8.4	2.25	2.45	1.2	4.0	8.0	Q3
LM4040DEM3-2.0	SOT-23	DBZ	3	1000	178.0	8.4	3.3	2.9	1.22	4.0	8.0	Q3
LM4040DEM3-2.0/NOPB	SOT-23	DBZ	3	1000	178.0	8.4	3.3	2.9	1.22	4.0	8.0	Q3
LM4040DEM3-2.5/NOPB	SOT-23	DBZ	3	1000	178.0	8.4	3.3	2.9	1.22	4.0	8.0	Q3
LM4040DEM3-3.0/NOPB	SOT-23	DBZ	3	1000	178.0	8.4	3.3	2.9	1.22	4.0	8.0	Q3
LM4040DEM3-5.0	SOT-23	DBZ	3	1000	178.0	8.4	3.3	2.9	1.22	4.0	8.0	Q3
LM4040DEM3-5.0/NOPB	SOT-23	DBZ	3	1000	178.0	8.4	3.3	2.9	1.22	4.0	8.0	Q3
LM4040DEM3X-2.5/NOPB	SOT-23	DBZ	3	3000	178.0	8.4	3.3	2.9	1.22	4.0	8.0	Q3
LM4040DEM3X-5.0	SOT-23	DBZ	3	3000	178.0	8.4	3.3	2.9	1.22	4.0	8.0	Q3
LM4040DEM3X-5.0/NOPB	SOT-23	DBZ	3	3000	178.0	8.4	3.3	2.9	1.22	4.0	8.0	Q3
LM4040DIM3-10.0	SOT-23	DBZ	3	1000	178.0	8.4	3.3	2.9	1.22	4.0	8.0	Q3
LM4040DIM3-10.0/NOPB	SOT-23	DBZ	3	1000	178.0	8.4	3.3	2.9	1.22	4.0	8.0	Q3
LM4040DIM3-2.0/NOPB	SOT-23	DBZ	3	1000	178.0	8.4	3.3	2.9	1.22	4.0	8.0	Q3
LM4040DIM3-2.5	SOT-23	DBZ	3	1000	178.0	8.4	3.3	2.9	1.22	4.0	8.0	Q3
LM4040DIM3-2.5/NOPB	SOT-23	DBZ	3	1000	178.0	8.4	3.3	2.9	1.22	4.0	8.0	Q3
LM4040DIM3-3.0	SOT-23	DBZ	3	1000	178.0	8.4	3.3	2.9	1.22	4.0	8.0	Q3
LM4040DIM3-3.0/NOPB	SOT-23	DBZ	3	1000	178.0	8.4	3.3	2.9	1.22	4.0	8.0	Q3
LM4040DIM3-4.1	SOT-23	DBZ	3	1000	178.0	8.4	3.3	2.9	1.22	4.0	8.0	Q3
LM4040DIM3-4.1/NOPB	SOT-23	DBZ	3	1000	178.0	8.4	3.3	2.9	1.22	4.0	8.0	Q3
LM4040DIM3-5.0	SOT-23	DBZ	3	1000	178.0	8.4	3.3	2.9	1.22	4.0	8.0	Q3

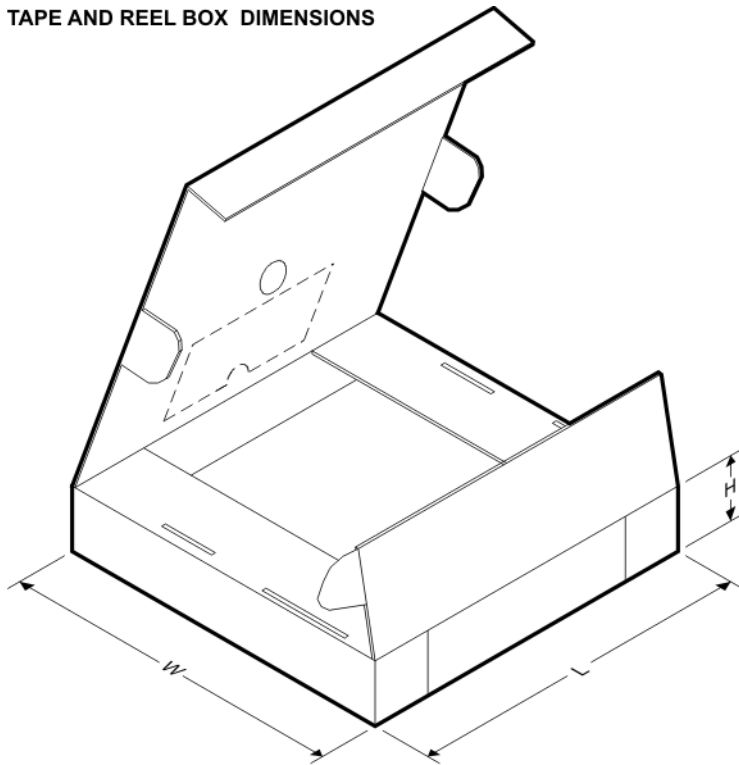
Device	Package Type	Package Drawing	Pins	SPQ	Reel Diameter (mm)	Reel Width W1 (mm)	A0 (mm)	B0 (mm)	K0 (mm)	P1 (mm)	W (mm)	Pin1 Quadrant
LM4040DIM3-5.0/NOPB	SOT-23	DBZ	3	1000	178.0	8.4	3.3	2.9	1.22	4.0	8.0	Q3
LM4040DIM3-8.2/NOPB	SOT-23	DBZ	3	1000	178.0	8.4	3.3	2.9	1.22	4.0	8.0	Q3
LM4040DIM3X-10	SOT-23	DBZ	3	3000	178.0	8.4	3.3	2.9	1.22	4.0	8.0	Q3
LM4040DIM3X-10/NOPB	SOT-23	DBZ	3	3000	178.0	8.4	3.3	2.9	1.22	4.0	8.0	Q3
LM4040DIM3X-2.0/NOPB	SOT-23	DBZ	3	3000	178.0	8.4	3.3	2.9	1.22	4.0	8.0	Q3
LM4040DIM3X-2.5	SOT-23	DBZ	3	3000	178.0	8.4	3.3	2.9	1.22	4.0	8.0	Q3
LM4040DIM3X-2.5/NOPB	SOT-23	DBZ	3	3000	178.0	8.4	3.3	2.9	1.22	4.0	8.0	Q3
LM4040DIM3X-3.0/NOPB	SOT-23	DBZ	3	3000	178.0	8.4	3.3	2.9	1.22	4.0	8.0	Q3
LM4040DIM3X-4.1	SOT-23	DBZ	3	3000	178.0	8.4	3.3	2.9	1.22	4.0	8.0	Q3
LM4040DIM3X-4.1/NOPB	SOT-23	DBZ	3	3000	178.0	8.4	3.3	2.9	1.22	4.0	8.0	Q3
LM4040DIM3X-5.0	SOT-23	DBZ	3	3000	178.0	8.4	3.3	2.9	1.22	4.0	8.0	Q3
LM4040DIM3X-5.0/NOPB	SOT-23	DBZ	3	3000	178.0	8.4	3.3	2.9	1.22	4.0	8.0	Q3
LM4040DIM7-2.0/NOPB	SC70	DCK	5	1000	178.0	8.4	2.25	2.45	1.2	4.0	8.0	Q3
LM4040DIM7-2.5/NOPB	SC70	DCK	5	1000	178.0	8.4	2.25	2.45	1.2	4.0	8.0	Q3
LM4040DIM7-5.0	SC70	DCK	5	1000	178.0	8.4	2.25	2.45	1.2	4.0	8.0	Q3
LM4040DIM7-5.0/NOPB	SC70	DCK	5	1000	178.0	8.4	2.25	2.45	1.2	4.0	8.0	Q3
LM4040EEM3-2.5/NOPB	SOT-23	DBZ	3	1000	178.0	8.4	3.3	2.9	1.22	4.0	8.0	Q3
LM4040EEM3-3.0/NOPB	SOT-23	DBZ	3	1000	178.0	8.4	3.3	2.9	1.22	4.0	8.0	Q3
LM4040EIM3-2.5	SOT-23	DBZ	3	1000	178.0	8.4	3.3	2.9	1.22	4.0	8.0	Q3
LM4040EIM3-2.5/NOPB	SOT-23	DBZ	3	1000	178.0	8.4	3.3	2.9	1.22	4.0	8.0	Q3
LM4040EIM3-3.0/NOPB	SOT-23	DBZ	3	1000	178.0	8.4	3.3	2.9	1.22	4.0	8.0	Q3
LM4040EIM3X-2.5	SOT-23	DBZ	3	3000	178.0	8.4	3.3	2.9	1.22	4.0	8.0	Q3
LM4040EIM3X-2.5/NOPB	SOT-23	DBZ	3	3000	178.0	8.4	3.3	2.9	1.22	4.0	8.0	Q3
LM4040EIM3X-3.0/NOPB	SOT-23	DBZ	3	3000	178.0	8.4	3.3	2.9	1.22	4.0	8.0	Q3
LM4040EIM7-2.0/NOPB	SC70	DCK	5	1000	178.0	8.4	2.25	2.45	1.2	4.0	8.0	Q3
LM4040QAIM3-2.5/NOPB	SOT-23	DBZ	3	1000	178.0	8.4	3.3	2.9	1.22	4.0	8.0	Q3
LM4040QAIM3X2.5/NOPB	SOT-23	DBZ	3	3000	178.0	8.4	3.3	2.9	1.22	4.0	8.0	Q3
LM4040QBIM3-2.5/NOPB	SOT-23	DBZ	3	1000	178.0	8.4	3.3	2.9	1.22	4.0	8.0	Q3
LM4040QBIM3X2.5/NOPB	SOT-23	DBZ	3	3000	178.0	8.4	3.3	2.9	1.22	4.0	8.0	Q3
LM4040QCEM3-2.5/NOP B	SOT-23	DBZ	3	1000	178.0	8.4	3.3	2.9	1.22	4.0	8.0	Q3
LM4040QCIM3-2.5/NOPB	SOT-23	DBZ	3	1000	178.0	8.4	3.3	2.9	1.22	4.0	8.0	Q3
LM4040QCIM3X2.5/NOP B	SOT-23	DBZ	3	3000	178.0	8.4	3.3	2.9	1.22	4.0	8.0	Q3
LM4040QDEM3-2.5/NOP B	SOT-23	DBZ	3	1000	178.0	8.4	3.3	2.9	1.22	4.0	8.0	Q3
LM4040QDIM3-2.5/NOPB	SOT-23	DBZ	3	1000	178.0	8.4	3.3	2.9	1.22	4.0	8.0	Q3
LM4040QDIM3X2.5/NOP B	SOT-23	DBZ	3	3000	178.0	8.4	3.3	2.9	1.22	4.0	8.0	Q3
LM4040QEEM3-2.5/NOP B	SOT-23	DBZ	3	1000	178.0	8.4	3.3	2.9	1.22	4.0	8.0	Q3
LM4040QEIM3-2.5/NOPB	SOT-23	DBZ	3	1000	178.0	8.4	3.3	2.9	1.22	4.0	8.0	Q3
LM4040QEIM3X2.5/NOPB	SOT-23	DBZ	3	3000	178.0	8.4	3.3	2.9	1.22	4.0	8.0	Q3

TAPE AND REEL BOX DIMENSIONS

*All dimensions are nominal

Device	Package Type	Package Drawing	Pins	SPQ	Length (mm)	Width (mm)	Height (mm)
LM4040AIM3-10.0	SOT-23	DBZ	3	1000	203.0	190.0	41.0
LM4040AIM3-10.0/NOPB	SOT-23	DBZ	3	1000	203.0	190.0	41.0
LM4040AIM3-2.0	SOT-23	DBZ	3	1000	203.0	190.0	41.0
LM4040AIM3-2.0/NOPB	SOT-23	DBZ	3	1000	203.0	190.0	41.0
LM4040AIM3-2.5	SOT-23	DBZ	3	1000	203.0	190.0	41.0
LM4040AIM3-2.5/NOPB	SOT-23	DBZ	3	1000	203.0	190.0	41.0
LM4040AIM3-3.0	SOT-23	DBZ	3	1000	203.0	190.0	41.0
LM4040AIM3-3.0/NOPB	SOT-23	DBZ	3	1000	203.0	190.0	41.0
LM4040AIM3-4.1	SOT-23	DBZ	3	1000	203.0	190.0	41.0
LM4040AIM3-4.1/NOPB	SOT-23	DBZ	3	1000	203.0	190.0	41.0
LM4040AIM3-5.0	SOT-23	DBZ	3	1000	203.0	190.0	41.0
LM4040AIM3-5.0/NOPB	SOT-23	DBZ	3	1000	203.0	190.0	41.0
LM4040AIM3X-10	SOT-23	DBZ	3	3000	206.0	191.0	90.0
LM4040AIM3X-10/NOPB	SOT-23	DBZ	3	3000	206.0	191.0	90.0
LM4040AIM3X-2.0/NOPB	SOT-23	DBZ	3	3000	206.0	191.0	90.0
LM4040AIM3X-2.5	SOT-23	DBZ	3	3000	206.0	191.0	90.0
LM4040AIM3X-2.5/NOPB	SOT-23	DBZ	3	3000	206.0	191.0	90.0
LM4040AIM3X-3.0/NOPB	SOT-23	DBZ	3	3000	206.0	191.0	90.0
LM4040AIM3X-4.1/NOPB	SOT-23	DBZ	3	3000	206.0	191.0	90.0
LM4040AIM3X-5.0	SOT-23	DBZ	3	3000	206.0	191.0	90.0

Device	Package Type	Package Drawing	Pins	SPQ	Length (mm)	Width (mm)	Height (mm)
LM4040AIM3X-5.0/NOPB	SOT-23	DBZ	3	3000	206.0	191.0	90.0
LM4040BIM3-10.0	SOT-23	DBZ	3	1000	203.0	190.0	41.0
LM4040BIM3-10.0/NOPB	SOT-23	DBZ	3	1000	203.0	190.0	41.0
LM4040BIM3-2.0/NOPB	SOT-23	DBZ	3	1000	203.0	190.0	41.0
LM4040BIM3-2.5	SOT-23	DBZ	3	1000	203.0	190.0	41.0
LM4040BIM3-2.5/NOPB	SOT-23	DBZ	3	1000	203.0	190.0	41.0
LM4040BIM3-3.0	SOT-23	DBZ	3	1000	203.0	190.0	41.0
LM4040BIM3-3.0/NOPB	SOT-23	DBZ	3	1000	203.0	190.0	41.0
LM4040BIM3-4.1	SOT-23	DBZ	3	1000	203.0	190.0	41.0
LM4040BIM3-4.1/NOPB	SOT-23	DBZ	3	1000	203.0	190.0	41.0
LM4040BIM3-5.0	SOT-23	DBZ	3	1000	203.0	190.0	41.0
LM4040BIM3-5.0/NOPB	SOT-23	DBZ	3	1000	203.0	190.0	41.0
LM4040BIM3-8.2	SOT-23	DBZ	3	1000	203.0	190.0	41.0
LM4040BIM3-8.2/NOPB	SOT-23	DBZ	3	1000	203.0	190.0	41.0
LM4040BIM3X-10	SOT-23	DBZ	3	3000	206.0	191.0	90.0
LM4040BIM3X-10/NOPB	SOT-23	DBZ	3	3000	206.0	191.0	90.0
LM4040BIM3X-2.0/NOPB	SOT-23	DBZ	3	3000	206.0	191.0	90.0
LM4040BIM3X-2.5	SOT-23	DBZ	3	3000	206.0	191.0	90.0
LM4040BIM3X-2.5/NOPB	SOT-23	DBZ	3	3000	206.0	191.0	90.0
LM4040BIM3X-3.0/NOPB	SOT-23	DBZ	3	3000	206.0	191.0	90.0
LM4040BIM3X-4.1	SOT-23	DBZ	3	3000	206.0	191.0	90.0
LM4040BIM3X-4.1/NOPB	SOT-23	DBZ	3	3000	206.0	191.0	90.0
LM4040BIM3X-5.0	SOT-23	DBZ	3	3000	206.0	191.0	90.0
LM4040BIM3X-5.0/NOPB	SOT-23	DBZ	3	3000	206.0	191.0	90.0
LM4040BIM7-2.0/NOPB	SC70	DCK	5	1000	203.0	190.0	41.0
LM4040BIM7-2.5	SC70	DCK	5	1000	203.0	190.0	41.0
LM4040BIM7-2.5/NOPB	SC70	DCK	5	1000	203.0	190.0	41.0
LM4040BIM7-5.0/NOPB	SC70	DCK	5	1000	203.0	190.0	41.0
LM4040BIM7X-2.5/NOPB	SC70	DCK	5	3000	206.0	191.0	90.0
LM4040CEM3-2.5	SOT-23	DBZ	3	1000	203.0	190.0	41.0
LM4040CEM3-2.5/NOPB	SOT-23	DBZ	3	1000	203.0	190.0	41.0
LM4040CEM3-3.0/NOPB	SOT-23	DBZ	3	1000	203.0	190.0	41.0
LM4040CEM3-5.0	SOT-23	DBZ	3	1000	203.0	190.0	41.0
LM4040CEM3-5.0/NOPB	SOT-23	DBZ	3	1000	203.0	190.0	41.0
LM4040CEM3X-3.0/NOPB	SOT-23	DBZ	3	3000	206.0	191.0	90.0
LM4040CEM3X-5.0	SOT-23	DBZ	3	3000	206.0	191.0	90.0
LM4040CEM3X-5.0/NOPB	SOT-23	DBZ	3	3000	206.0	191.0	90.0
LM4040CIM3-10.0	SOT-23	DBZ	3	1000	203.0	190.0	41.0
LM4040CIM3-10.0/NOPB	SOT-23	DBZ	3	1000	203.0	190.0	41.0
LM4040CIM3-2.0	SOT-23	DBZ	3	1000	203.0	190.0	41.0
LM4040CIM3-2.0/NOPB	SOT-23	DBZ	3	1000	203.0	190.0	41.0
LM4040CIM3-2.5	SOT-23	DBZ	3	1000	203.0	190.0	41.0
LM4040CIM3-2.5/NOPB	SOT-23	DBZ	3	1000	203.0	190.0	41.0
LM4040CIM3-3.0	SOT-23	DBZ	3	1000	203.0	190.0	41.0

Device	Package Type	Package Drawing	Pins	SPQ	Length (mm)	Width (mm)	Height (mm)
LM4040CIM3-3.0/NOPB	SOT-23	DBZ	3	1000	203.0	190.0	41.0
LM4040CIM3-4.1	SOT-23	DBZ	3	1000	203.0	190.0	41.0
LM4040CIM3-4.1/NOPB	SOT-23	DBZ	3	1000	203.0	190.0	41.0
LM4040CIM3-5.0	SOT-23	DBZ	3	1000	203.0	190.0	41.0
LM4040CIM3-5.0/NOPB	SOT-23	DBZ	3	1000	203.0	190.0	41.0
LM4040CIM3-8.2	SOT-23	DBZ	3	1000	203.0	190.0	41.0
LM4040CIM3-8.2/NOPB	SOT-23	DBZ	3	1000	203.0	190.0	41.0
LM4040CIM3X-10	SOT-23	DBZ	3	3000	206.0	191.0	90.0
LM4040CIM3X-10/NOPB	SOT-23	DBZ	3	3000	206.0	191.0	90.0
LM4040CIM3X-2.0/NOPB	SOT-23	DBZ	3	3000	206.0	191.0	90.0
LM4040CIM3X-2.5	SOT-23	DBZ	3	3000	206.0	191.0	90.0
LM4040CIM3X-2.5/NOPB	SOT-23	DBZ	3	3000	206.0	191.0	90.0
LM4040CIM3X-3.0	SOT-23	DBZ	3	3000	206.0	191.0	90.0
LM4040CIM3X-3.0/NOPB	SOT-23	DBZ	3	3000	206.0	191.0	90.0
LM4040CIM3X-4.1	SOT-23	DBZ	3	3000	206.0	191.0	90.0
LM4040CIM3X-4.1/NOPB	SOT-23	DBZ	3	3000	206.0	191.0	90.0
LM4040CIM3X-5.0	SOT-23	DBZ	3	3000	206.0	191.0	90.0
LM4040CIM3X-5.0/NOPB	SOT-23	DBZ	3	3000	206.0	191.0	90.0
LM4040CIM7-2.0/NOPB	SC70	DCK	5	1000	203.0	190.0	41.0
LM4040CIM7-2.5/NOPB	SC70	DCK	5	1000	203.0	190.0	41.0
LM4040CIM7X-2.5/NOPB	SC70	DCK	5	3000	206.0	191.0	90.0
LM4040DEM3-2.0	SOT-23	DBZ	3	1000	203.0	190.0	41.0
LM4040DEM3-2.0/NOPB	SOT-23	DBZ	3	1000	203.0	190.0	41.0
LM4040DEM3-2.5/NOPB	SOT-23	DBZ	3	1000	203.0	190.0	41.0
LM4040DEM3-3.0/NOPB	SOT-23	DBZ	3	1000	203.0	190.0	41.0
LM4040DEM3-5.0	SOT-23	DBZ	3	1000	203.0	190.0	41.0
LM4040DEM3-5.0/NOPB	SOT-23	DBZ	3	1000	203.0	190.0	41.0
LM4040DEM3X-2.5/NOPB	SOT-23	DBZ	3	3000	206.0	191.0	90.0
LM4040DEM3X-5.0	SOT-23	DBZ	3	3000	206.0	191.0	90.0
LM4040DEM3X-5.0/NOPB	SOT-23	DBZ	3	3000	206.0	191.0	90.0
LM4040DIM3-10.0	SOT-23	DBZ	3	1000	203.0	190.0	41.0
LM4040DIM3-10.0/NOPB	SOT-23	DBZ	3	1000	203.0	190.0	41.0
LM4040DIM3-2.0/NOPB	SOT-23	DBZ	3	1000	203.0	190.0	41.0
LM4040DIM3-2.5	SOT-23	DBZ	3	1000	203.0	190.0	41.0
LM4040DIM3-2.5/NOPB	SOT-23	DBZ	3	1000	203.0	190.0	41.0
LM4040DIM3-3.0	SOT-23	DBZ	3	1000	203.0	190.0	41.0
LM4040DIM3-3.0/NOPB	SOT-23	DBZ	3	1000	203.0	190.0	41.0
LM4040DIM3-4.1	SOT-23	DBZ	3	1000	203.0	190.0	41.0
LM4040DIM3-4.1/NOPB	SOT-23	DBZ	3	1000	203.0	190.0	41.0
LM4040DIM3-5.0	SOT-23	DBZ	3	1000	203.0	190.0	41.0
LM4040DIM3-5.0/NOPB	SOT-23	DBZ	3	1000	203.0	190.0	41.0
LM4040DIM3-8.2/NOPB	SOT-23	DBZ	3	1000	203.0	190.0	41.0
LM4040DIM3X-10	SOT-23	DBZ	3	3000	206.0	191.0	90.0
LM4040DIM3X-10/NOPB	SOT-23	DBZ	3	3000	206.0	191.0	90.0

Device	Package Type	Package Drawing	Pins	SPQ	Length (mm)	Width (mm)	Height (mm)
LM4040DIM3X-2.0/NOPB	SOT-23	DBZ	3	3000	206.0	191.0	90.0
LM4040DIM3X-2.5	SOT-23	DBZ	3	3000	206.0	191.0	90.0
LM4040DIM3X-2.5/NOPB	SOT-23	DBZ	3	3000	206.0	191.0	90.0
LM4040DIM3X-3.0/NOPB	SOT-23	DBZ	3	3000	206.0	191.0	90.0
LM4040DIM3X-4.1	SOT-23	DBZ	3	3000	206.0	191.0	90.0
LM4040DIM3X-4.1/NOPB	SOT-23	DBZ	3	3000	206.0	191.0	90.0
LM4040DIM3X-5.0	SOT-23	DBZ	3	3000	206.0	191.0	90.0
LM4040DIM3X-5.0/NOPB	SOT-23	DBZ	3	3000	206.0	191.0	90.0
LM4040DIM7-2.0/NOPB	SC70	DCK	5	1000	203.0	190.0	41.0
LM4040DIM7-2.5/NOPB	SC70	DCK	5	1000	203.0	190.0	41.0
LM4040DIM7-5.0	SC70	DCK	5	1000	203.0	190.0	41.0
LM4040DIM7-5.0/NOPB	SC70	DCK	5	1000	203.0	190.0	41.0
LM4040EEM3-2.5/NOPB	SOT-23	DBZ	3	1000	203.0	190.0	41.0
LM4040EEM3-3.0/NOPB	SOT-23	DBZ	3	1000	203.0	190.0	41.0
LM4040EIM3-2.5	SOT-23	DBZ	3	1000	203.0	190.0	41.0
LM4040EIM3-2.5/NOPB	SOT-23	DBZ	3	1000	203.0	190.0	41.0
LM4040EIM3-3.0/NOPB	SOT-23	DBZ	3	1000	203.0	190.0	41.0
LM4040EIM3X-2.5	SOT-23	DBZ	3	3000	206.0	191.0	90.0
LM4040EIM3X-2.5/NOPB	SOT-23	DBZ	3	3000	206.0	191.0	90.0
LM4040EIM3X-3.0/NOPB	SOT-23	DBZ	3	3000	206.0	191.0	90.0
LM4040EIM7-2.0/NOPB	SC70	DCK	5	1000	203.0	190.0	41.0
LM4040QAIM3-2.5/NOPB	SOT-23	DBZ	3	1000	203.0	190.0	41.0
LM4040QAIM3X2.5/NOPB	SOT-23	DBZ	3	3000	206.0	191.0	90.0
LM4040QBIM3-2.5/NOPB	SOT-23	DBZ	3	1000	203.0	190.0	41.0
LM4040QBIM3X2.5/NOPB	SOT-23	DBZ	3	3000	206.0	191.0	90.0
LM4040QCEM3-2.5/NOPB	SOT-23	DBZ	3	1000	203.0	190.0	41.0
LM4040QCIM3-2.5/NOPB	SOT-23	DBZ	3	1000	203.0	190.0	41.0
LM4040QCIM3X2.5/NOPB	SOT-23	DBZ	3	3000	206.0	191.0	90.0
LM4040QDEM3-2.5/NOPB	SOT-23	DBZ	3	1000	203.0	190.0	41.0
LM4040QDIM3-2.5/NOPB	SOT-23	DBZ	3	1000	203.0	190.0	41.0
LM4040QDIM3X2.5/NOPB	SOT-23	DBZ	3	3000	206.0	191.0	90.0
LM4040QEEM3-2.5/NOPB	SOT-23	DBZ	3	1000	203.0	190.0	41.0
LM4040QEIM3-2.5/NOPB	SOT-23	DBZ	3	1000	203.0	190.0	41.0
LM4040QEIM3X2.5/NOPB	SOT-23	DBZ	3	3000	206.0	191.0	90.0

DCK (R-PDSO-G5)

PLASTIC SMALL-OUTLINE PACKAGE

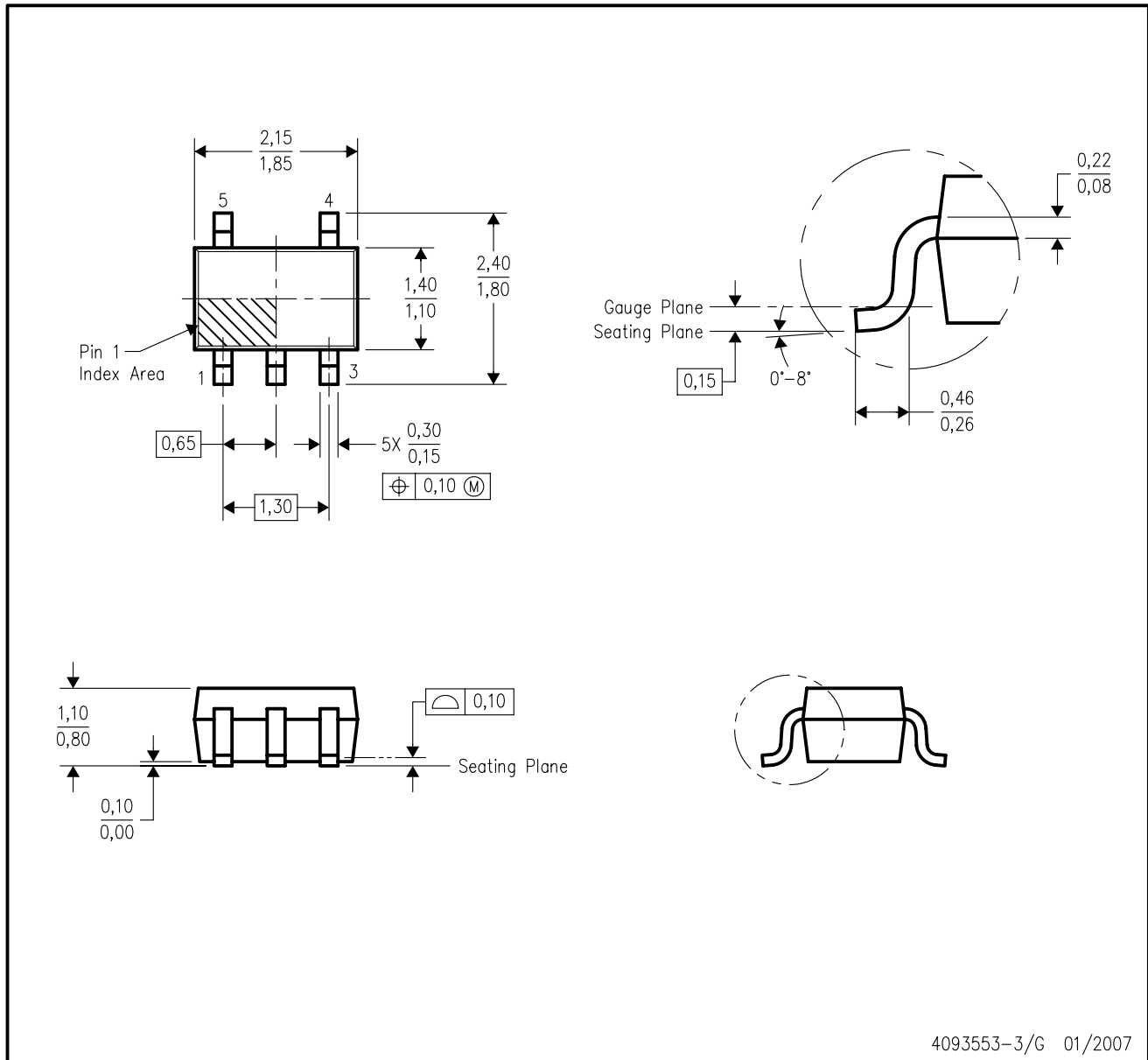

- NOTES:
- A. All linear dimensions are in millimeters.
 - B. This drawing is subject to change without notice.
 - C. Body dimensions do not include mold flash or protrusion. Mold flash and protrusion shall not exceed 0.15 per side.
 - D. Falls within JEDEC MO-203 variation AA.

DBZ (R-PDSO-G3)

PLASTIC SMALL-OUTLINE

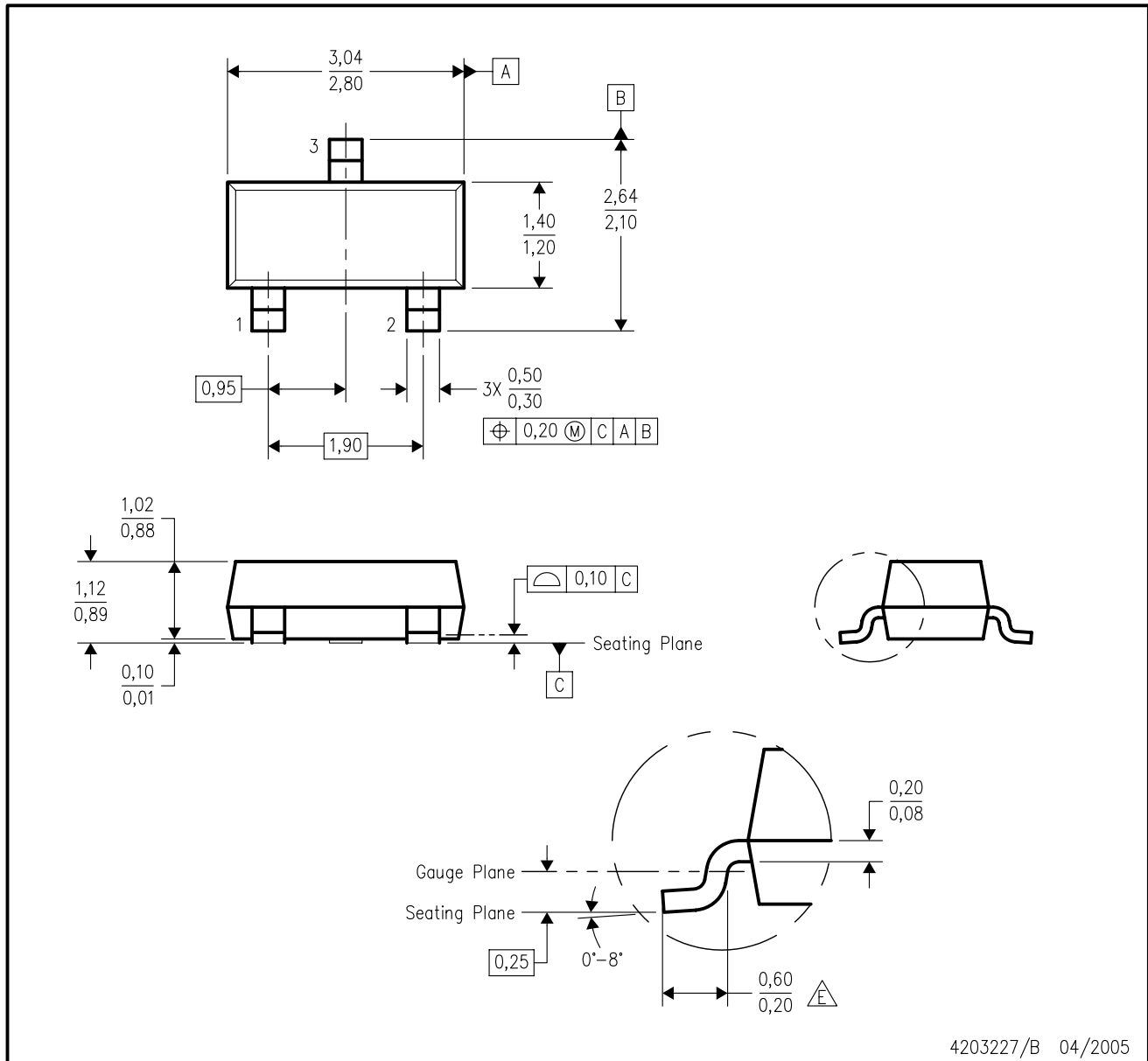

- NOTES:
- A. All linear dimensions are in millimeters. Dimensioning and tolerancing per ASME Y14.5M-1994.
 - B. This drawing is subject to change without notice.
 - C. Lead dimensions are inclusive of plating.
 - D. Body dimensions are exclusive of mold flash and protrusion. Mold flash and protrusion not to exceed 0.25 per side.
 - $\triangle E$ Falls within JEDEC TO-236 variation AB, except minimum foot length.

LP (O-PBCY-W3)

PLASTIC CYLINDRICAL PACKAGE

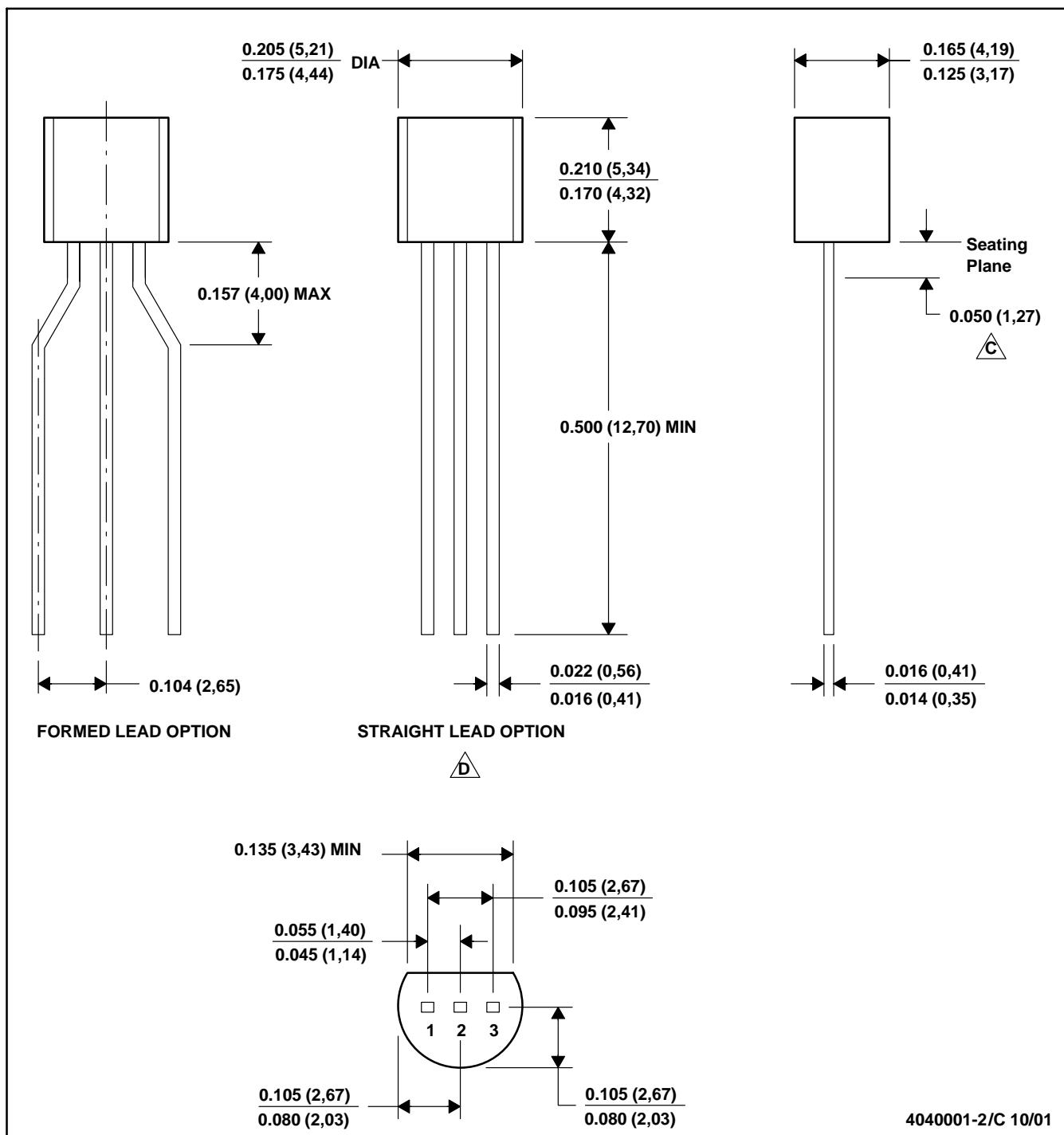

- NOTES: A. All linear dimensions are in inches (millimeters).
 B. This drawing is subject to change without notice.
 C. Lead dimensions are not controlled within this area
 D. Falls within JEDEC TO -226 Variation AA (TO-226 replaces TO-92)
 E. Shipping Method:
 Straight lead option available in bulk pack only.
 Formed lead option available in tape & reel or ammo pack.

MECHANICAL DATA

MSOT002A – OCTOBER 1994 – REVISED NOVEMBER 2001

LP (O-PBCY-W3)

PLASTIC CYLINDRICAL PACKAGE

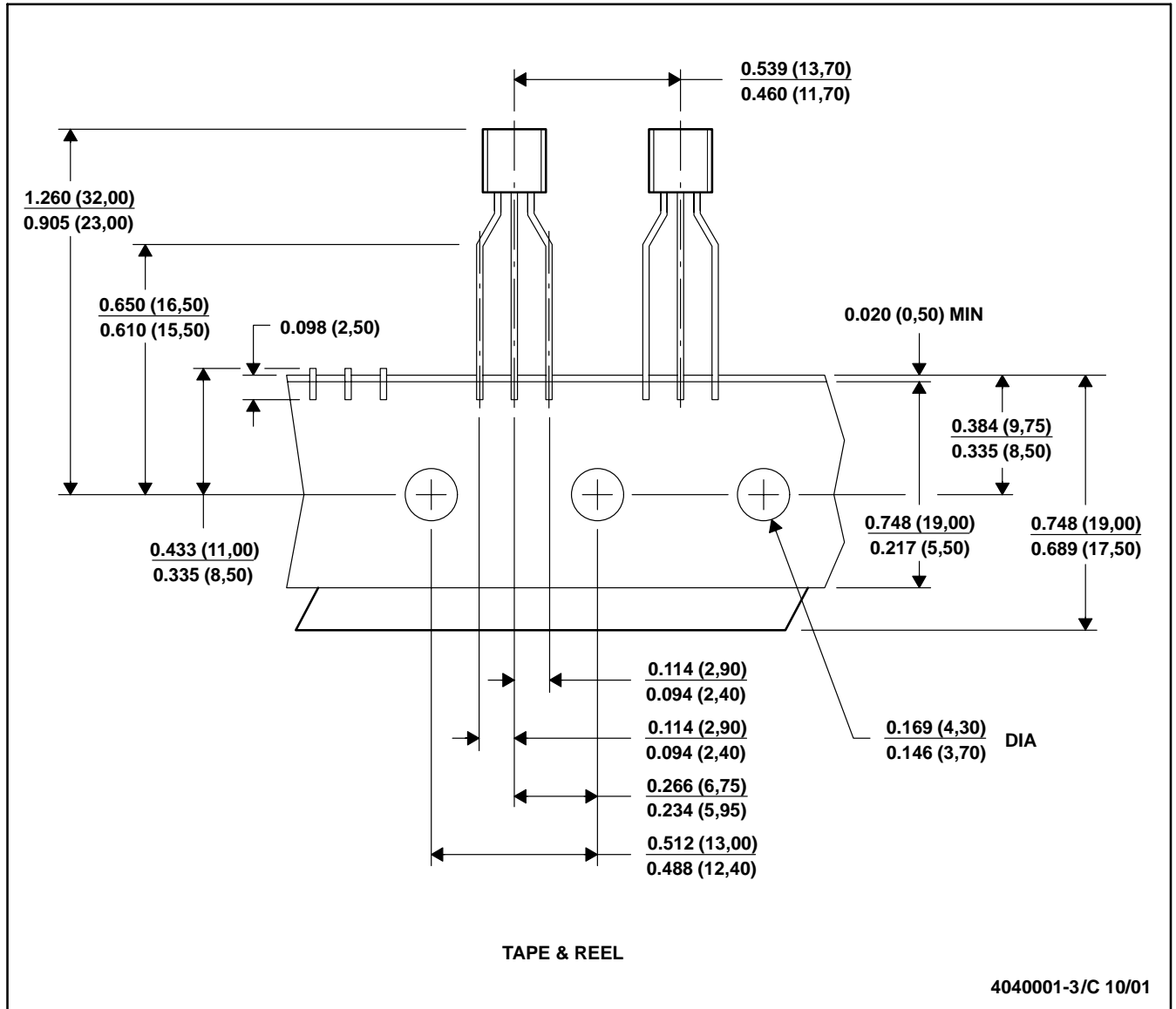

- NOTES: A. All linear dimensions are in inches (millimeters).
 B. This drawing is subject to change without notice.
 C. Tape and Reel information for the Format Lead Option package.

IMPORTANT NOTICE

Texas Instruments Incorporated and its subsidiaries (TI) reserve the right to make corrections, enhancements, improvements and other changes to its semiconductor products and services per JESD46, latest issue, and to discontinue any product or service per JESD48, latest issue. Buyers should obtain the latest relevant information before placing orders and should verify that such information is current and complete. All semiconductor products (also referred to herein as "components") are sold subject to TI's terms and conditions of sale supplied at the time of order acknowledgment.

TI warrants performance of its components to the specifications applicable at the time of sale, in accordance with the warranty in TI's terms and conditions of sale of semiconductor products. Testing and other quality control techniques are used to the extent TI deems necessary to support this warranty. Except where mandated by applicable law, testing of all parameters of each component is not necessarily performed.

TI assumes no liability for applications assistance or the design of Buyers' products. Buyers are responsible for their products and applications using TI components. To minimize the risks associated with Buyers' products and applications, Buyers should provide adequate design and operating safeguards.

TI does not warrant or represent that any license, either express or implied, is granted under any patent right, copyright, mask work right, or other intellectual property right relating to any combination, machine, or process in which TI components or services are used. Information published by TI regarding third-party products or services does not constitute a license to use such products or services or a warranty or endorsement thereof. Use of such information may require a license from a third party under the patents or other intellectual property of the third party, or a license from TI under the patents or other intellectual property of TI.

Reproduction of significant portions of TI information in TI data books or data sheets is permissible only if reproduction is without alteration and is accompanied by all associated warranties, conditions, limitations, and notices. TI is not responsible or liable for such altered documentation. Information of third parties may be subject to additional restrictions.

Resale of TI components or services with statements different from or beyond the parameters stated by TI for that component or service voids all express and any implied warranties for the associated TI component or service and is an unfair and deceptive business practice. TI is not responsible or liable for any such statements.

Buyer acknowledges and agrees that it is solely responsible for compliance with all legal, regulatory and safety-related requirements concerning its products, and any use of TI components in its applications, notwithstanding any applications-related information or support that may be provided by TI. Buyer represents and agrees that it has all the necessary expertise to create and implement safeguards which anticipate dangerous consequences of failures, monitor failures and their consequences, lessen the likelihood of failures that might cause harm and take appropriate remedial actions. Buyer will fully indemnify TI and its representatives against any damages arising out of the use of any TI components in safety-critical applications.

In some cases, TI components may be promoted specifically to facilitate safety-related applications. With such components, TI's goal is to help enable customers to design and create their own end-product solutions that meet applicable functional safety standards and requirements. Nonetheless, such components are subject to these terms.

No TI components are authorized for use in FDA Class III (or similar life-critical medical equipment) unless authorized officers of the parties have executed a special agreement specifically governing such use.

Only those TI components which TI has specifically designated as military grade or "enhanced plastic" are designed and intended for use in military/aerospace applications or environments. Buyer acknowledges and agrees that any military or aerospace use of TI components which have **not** been so designated is solely at the Buyer's risk, and that Buyer is solely responsible for compliance with all legal and regulatory requirements in connection with such use.

TI has specifically designated certain components as meeting ISO/TS16949 requirements, mainly for automotive use. In any case of use of non-designated products, TI will not be responsible for any failure to meet ISO/TS16949.

Products

Audio	www.ti.com/audio
Amplifiers	amplifier.ti.com
Data Converters	dataconverter.ti.com
DLP® Products	www.dlp.com
DSP	dsp.ti.com
Clocks and Timers	www.ti.com/clocks
Interface	interface.ti.com
Logic	logic.ti.com
Power Mgmt	power.ti.com
Microcontrollers	microcontroller.ti.com
RFID	www.ti-rfid.com
OMAP Applications Processors	www.ti.com/omap
Wireless Connectivity	www.ti.com/wirelessconnectivity

Applications

Automotive and Transportation	www.ti.com/automotive
Communications and Telecom	www.ti.com/communications
Computers and Peripherals	www.ti.com/computers
Consumer Electronics	www.ti.com/consumer-apps
Energy and Lighting	www.ti.com/energy
Industrial	www.ti.com/industrial
Medical	www.ti.com/medical
Security	www.ti.com/security
Space, Avionics and Defense	www.ti.com/space-avionics-defense
Video and Imaging	www.ti.com/video

TI E2E Community

e2e.ti.com