



## ULTRA-SMALL SUPPLY VOLTAGE SUPERVISORS

### FEATURES

- Small, 5-Pin SC-70 (SOT-323) Package
- Supply Current of 9  $\mu$ A
- Power-On Reset Generator With Fixed Delay Time
  - TPS3800 = 100 ms
  - TPS3801 = 200 ms
  - TPS3802 = 400 ms
- Precision Supply Voltage Monitor 1.8 V, 2.5 V, 2.7 V, 3 V, 3.3 V, 5 V, and Adjustable
- Manual Reset Input (Except TPS3801-01)
- Temperature Range: -40°C to 85°C

### APPLICATIONS

- Applications Using DSPs, Microcontrollers, or Microprocessors
- Wireless Communication Systems
- Portable/Battery-Powered Equipment
- Programmable Controls
- Intelligent Instruments
- Industrial Equipment
- Notebook/Desktop Computers
- Automotive Systems

### DESCRIPTION

The TPS380x family of supervisory circuits monitor supply voltages to provide circuit initialization and timing supervision, primarily for DSPs and other processor-based systems.

These devices assert a push-pull  $\overline{\text{RESET}}$  signal when the SENSE (adjustable version) or  $V_{\text{DD}}$  (fixed version) drops below a preset threshold. The  $\overline{\text{RESET}}$  output remains asserted for the factory programmed delay time after the SENSE or  $V_{\text{DD}}$  return above its threshold.

The TPS380x devices, except the TPS3801-01, incorporate a manual reset input ( $\overline{\text{MR}}$ ). A low level at  $\overline{\text{MR}}$  causes  $\overline{\text{RESET}}$  to become active.

The TPS380x uses a precision reference to achieve an overall threshold accuracy of 2% - 2.5%. These devices are available in a 5-pin SC-70 package, which is only about half the size of a 5-pin SOT-23 package.

The TPS380x devices are fully specified over a temperature range of -40°C to 85°C.

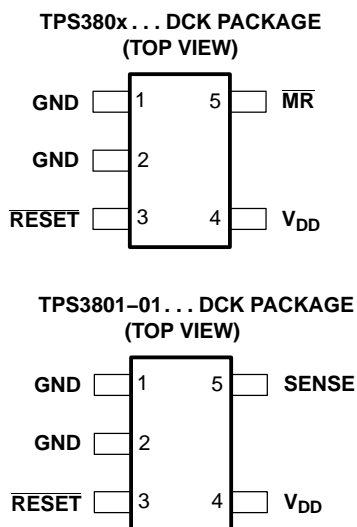

### typical applications

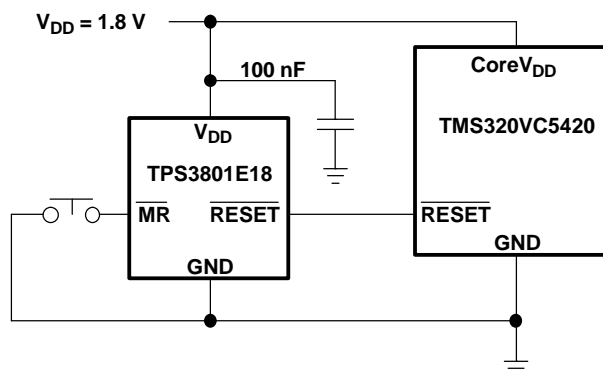

Please be aware that an important notice concerning availability, standard warranty, and use in critical applications of Texas Instruments semiconductor products and disclaimers thereto appears at the end of this data sheet.



These devices have limited built-in ESD protection. The leads should be shorted together or the device placed in conductive foam during storage or handling to prevent electrostatic damage to the MOS gates.

### AVAILABLE OPTIONS

T <sub>A</sub>	Device name	THRESHOLD VOLTAGE	TYP DELAY TIME	MARKING
-40°C to 85°C	TPS3801-01DCK	Adjustable (V <sub>ref</sub> = 1.14 V)	200 ms	ARF
	TPS3801E18DCK	1.71 V	200 ms	ARE
	TPS3801J25DCK	2.25 V	200 ms	NJA
	TPS3800G27DCK	2.5 V	95 ms	ARI
	TPS3801L30DCK	2.64 V	200 ms	NPA
	TPS3801K33DCK	2.93 V	200 ms	NWA
	TPS3802L30DCK	2.64 V	380 ms	ASA
	TPS3802K33DCK	2.93 V	380 ms	ARK
	TPS3801T50DCK	4.00 V	25 ms	AVI
	TPS3801I50DCK	4.55 V	200 ms	NSA

### ABSOLUTE MAXIMUM RATINGS

over operating free-air temperature range (unless otherwise noted) (1) (2)

	UNIT
Supply voltage, V <sub>DD</sub>	7 V
All other pins	-0.3 V to 7 V
Maximum low-output current, I <sub>OL</sub>	5 mA
Maximum high-output current, I <sub>OH</sub>	-5 mA
Input-clamp current, I <sub>IK</sub> (V <sub>I</sub> < 0 or V <sub>I</sub> > V <sub>DD</sub> )	±20 mA
Output-clamp current, I <sub>OK</sub> (V <sub>O</sub> < 0 or V <sub>O</sub> > V <sub>DD</sub> )	±20 mA
Operating junction temperature range, T <sub>J</sub> (3)	-40°C to 85°C
Storage temperature range, T <sub>stg</sub>	-65°C to 150°C
Soldering temperature (3 seconds)	260°C

- (1) Stresses beyond those listed under "absolute maximum ratings" may cause permanent damage to the device. These are stress ratings only, and functional operation of the device at these or any other conditions beyond those indicated under "recommended operating conditions" is not implied. Exposure to absolute-maximum-rated conditions for extended periods may affect device reliability.
- (2) All voltage values are with respect to GND. For reliable operation, the device should not be operated at 7 V for more than t=1000h continuously.
- (3) Due to the low dissipation power of this device, it is assumed that T<sub>J</sub> = T<sub>A</sub>.

### RECOMMENDED OPERATING CONDITIONS

		min	max	unit
Supply voltage, V <sub>DD</sub>	TPS3801J25, TPS3801L30, TPS3801K33, TPS3801I50, TPS3801T50	2	6	V
	All other devices	1.6	4	
Input voltage, V <sub>I</sub>		0	V <sub>DD</sub> +0.3	V
High-level input voltage, V <sub>IH</sub>		0.7×V <sub>DD</sub>		V
Low-level input voltage, V <sub>IL</sub>			0.3×V <sub>DD</sub>	V
Input transition rise and fall rate at MR, Δt/ΔV			100	ns/V
Operating free-air temperature range, T <sub>A</sub>		-40	85	°C

## ELECTRICAL CHARACTERISTICS

over -40°C to 85°C free-air temperature range (unless otherwise noted)

parameter		test conditions	min	typ	max	unit	
V <sub>OH</sub>	High-level output voltage ( $\overline{\text{RESET}}$ )	V <sub>DD</sub> = 1.6 V to 6 V I <sub>OH</sub> = -500 μA	V <sub>DD</sub> -0.2			V	
		V <sub>DD</sub> = 3.3 V I <sub>OH</sub> = -2 mA	V <sub>DD</sub> -0.4				
		V <sub>DD</sub> = 6 V I <sub>OH</sub> = -4 mA (1)	V <sub>DD</sub> -0.4				
V <sub>OL</sub>	Low-level output voltage ( $\overline{\text{RESET}}$ )	V <sub>DD</sub> = 1.6 V to 6 V, I <sub>OL</sub> = 500 μA	0.2			V	
		V <sub>DD</sub> = 3.3 V, I <sub>OL</sub> = 2 mA	0.4				
		V <sub>DD</sub> = 6 V, I <sub>OL</sub> = 4 mA (1)	0.4				
Power-up reset voltage (2)		V <sub>DD</sub> ≥ 1.1 V, I <sub>OL</sub> = 50 μA	0.2			V	
V <sub>IT-</sub>	Negative-going input threshold voltage (3)	TPS380x-01	T <sub>A</sub> = -40°C to 85°C	1.117	1.14	1.163	V
		TPS380xE18		1.67	1.71	1.75	
		TPS380xJ25		2.2	2.25	2.3	
		TPS380xG27		2.45	2.5	2.55	
		TPS380xL30		2.58	2.64	2.7	
		TPS380xK33		2.87	2.93	2.99	
		TPS380xI50		4.45	4.55	4.65	
		TPS380xT50		3.92	4	4.08	
V <sub>hys</sub>	Threshold hysteresis	TPS380x-01	15			mV	
		TPS380xx18	25				
		TPS380xx25	30				
		TPS380xx27	35				
		TPS380xx30	35				
		TPS380xx33	40				
		TPS380xx50	60				
I <sub>IH</sub>	High-level input current ( $\overline{\text{MR}}$ )	$\overline{\text{MR}} = 0.7 \times V_{\text{DD}}$ , V <sub>DD</sub> = 6 V	-40	-60	-100	μA	
I <sub>IL</sub>	Low-level input current ( $\overline{\text{MR}}$ )	$\overline{\text{MR}} = 0$ V, V <sub>DD</sub> = 6 V	-130	-200	-340	μA	
I <sub>I</sub>	Input current (SENSE)		-25		25	nA	
I <sub>DD</sub>	Supply current	TPS3801J25, TPS3801L30, TPS3801K33, TPS3801I50, TPS3801T50	V <sub>DD</sub> = 2 V, $\overline{\text{MR}}$ and output unconnected	9 12		μA	
			V <sub>DD</sub> = 6 V, $\overline{\text{MR}}$ and output unconnected	20 25			
		TPS3801-01	V <sub>DD</sub> = 1.6 V, SENSE = 0 V to V <sub>DD</sub> , output unconnected	7	10		
			V <sub>DD</sub> = 4 V, SENSE = 0 V to V <sub>DD</sub> , output unconnected	9	12		
		TPS3801E18, TPS3800G27, TPS3802K33, TPS3802L30	V <sub>DD</sub> = 1.6 V, $\overline{\text{MR}}$ and output unconnected	8	11		
		V <sub>DD</sub> = 4 V, $\overline{\text{MR}}$ and output unconnected	13	18			
C <sub>i</sub>	Input capacitance	V <sub>I</sub> = 0 V to V <sub>DD</sub>	5		pF		

(1) Only valid for the TPS3801J25, TPS3801L30, TPS3801K33, TPS3801I50, and TPS3801T50.

(2) The lowest supply voltage at which  $\overline{\text{RESET}}$  becomes active.  $t_r, V_{\text{DD}} \geq 15 \mu\text{s/V}$ .

(3) To ensure the best stability of the threshold voltage, a bypass capacitor (0.1-μF ceramic) should be placed near the supply terminals.

TIMING REQUIREMENTS

at  $R_L = 1\text{ M}\Omega$ ,  $C_L = 50\text{ pF}$ ,  $T_A = 25^\circ\text{C}$

parameter		TEST CONDITIONS	min	TYP	max	unit	
$t_w$	Pulse width	at SENSE	$V_{DD} = 1.6\text{ V}, V_{IH} = 1.1 \times V_{IT-}, V_{IL} = 0.9 \times V_{IT-}$			1	$\mu\text{s}$
		at $V_{DD}$	$V_{DD} = V_{IT-} + 0.2\text{ V}, V_{DD} = V_{IT-} - 0.2\text{ V}$			3	
		at $\overline{\text{MR}}$	$V_{DD} \geq V_{IT-} + 0.2\text{ V}, V_{IL} = 0.3 \times V_{DD}, V_{IH} = 0.7 \times V_{DD}$			100	ns

SWITCHING CHARACTERISTICS

at  $R_L = 1\text{ M}\Omega$ ,  $C_L = 50\text{ pF}$ ,  $T_A = 25^\circ\text{C}$

parameter		TEST CONDITIONS	min	TYP	max	unit
$t_d$	$\overline{\text{RESET}}$ recovery delay time	TPS3801T50	15	25	35	ms
		TPS3800	60	95	140	
		TPS3801	120	200	280	
		TPS3802	240	380	560	
$t_{PHL}$	Propagation (delay) time, high-to-low-level output	$\overline{\text{MR}}$ to $\overline{\text{RESET}}$ delay	$V_{DD} \geq V_{IT-} + 0.2\text{ V}, V_{IL} = 0.3 \times V_{DD}, V_{IH} = 0.7 \times V_{DD}$		15	ns
		$V_{DD}$ to $\overline{\text{RESET}}$ delay	$V_{IL} = V_{IT-} - 0.2\text{ V}, V_{IH} = V_{IT-} + 0.2\text{ V}$		1	$\mu\text{s}$
		SENSE to $\overline{\text{RESET}}$				

FUNCTIONAL BLOCK DIAGRAM

FUNCTION/TRUTH TABLE, TPS380x

$\overline{\text{MR}}$	$V_{DD} > V_{IT}$	$\overline{\text{RESET}}$
L	0	L
L	1	L
H	0	L
H	1	H

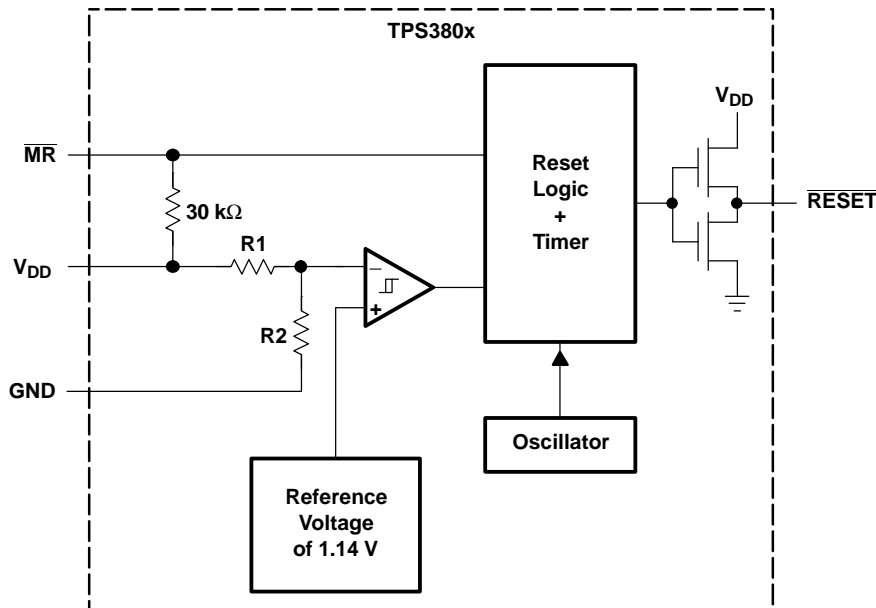

Figure 1. functional block diagram

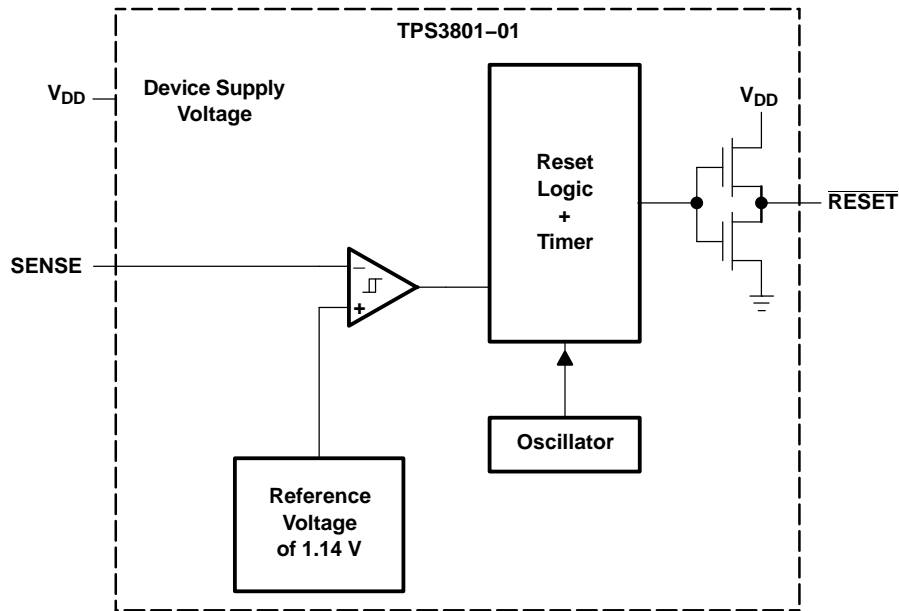
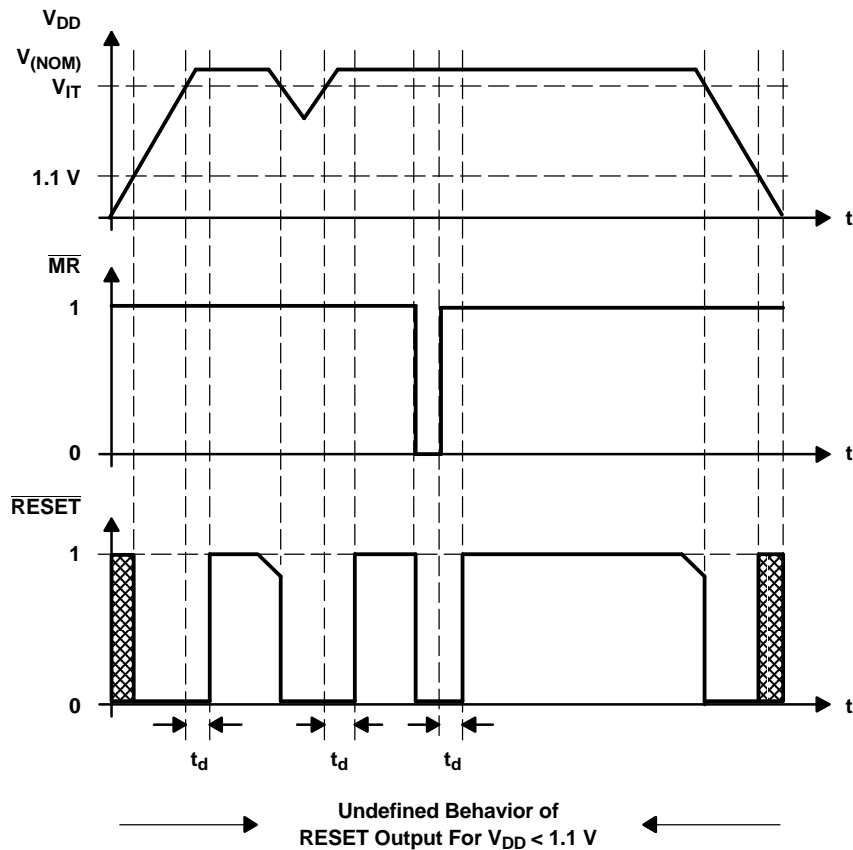

Figure 2. functional block diagram (continued)

### TIMING DIAGRAM



NOTE:  $\overline{\text{RESET}}$  should not be forced high during the power-up sequence (until  $V_{\text{DD}} > 1.1 \text{ V}$ ).

TYPICAL CHARACTERISTICS

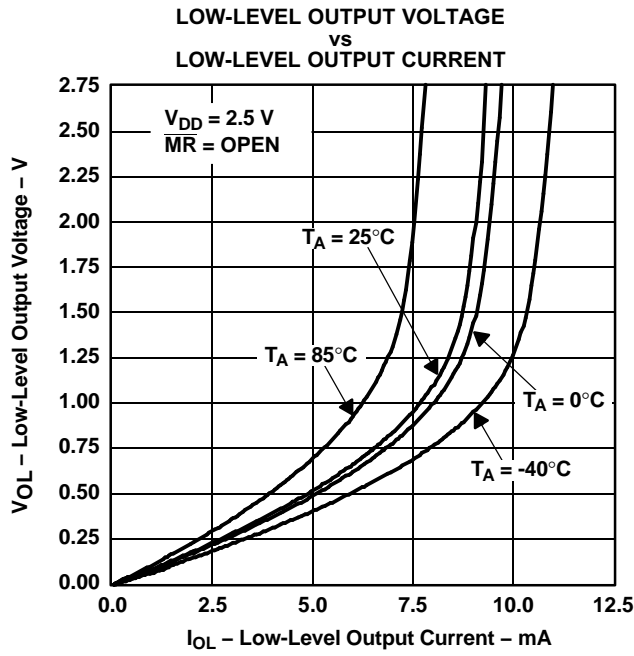

Figure 3.

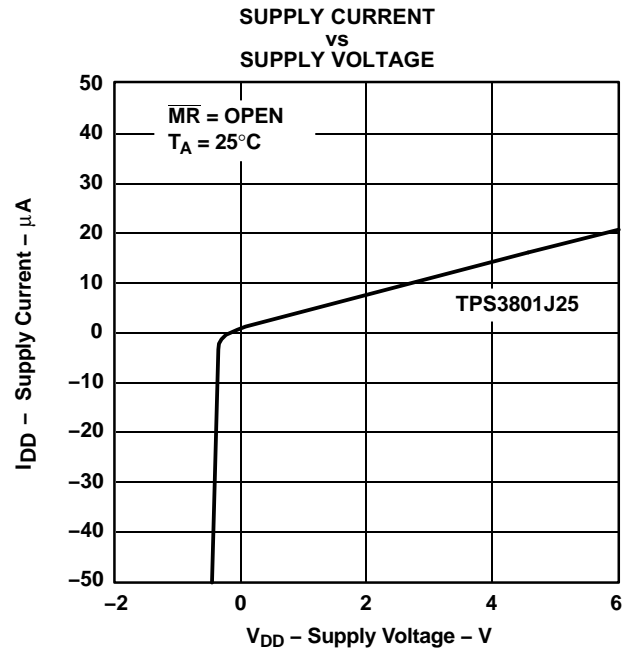

Figure 4.

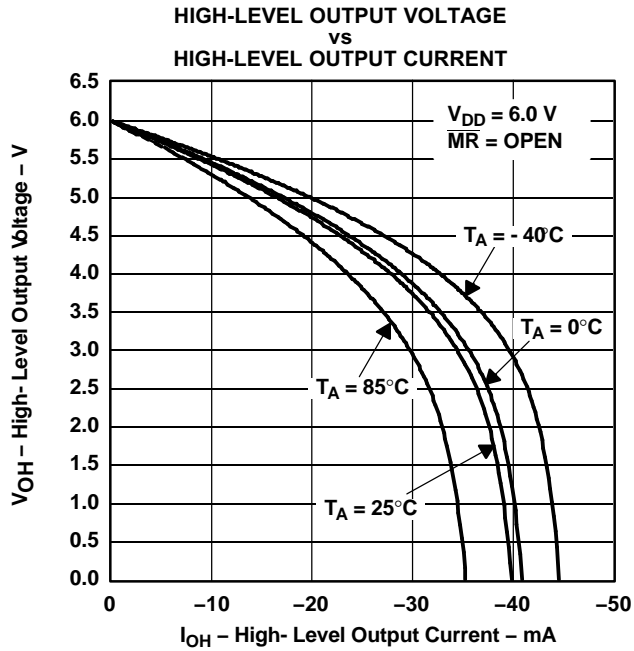

Figure 5.

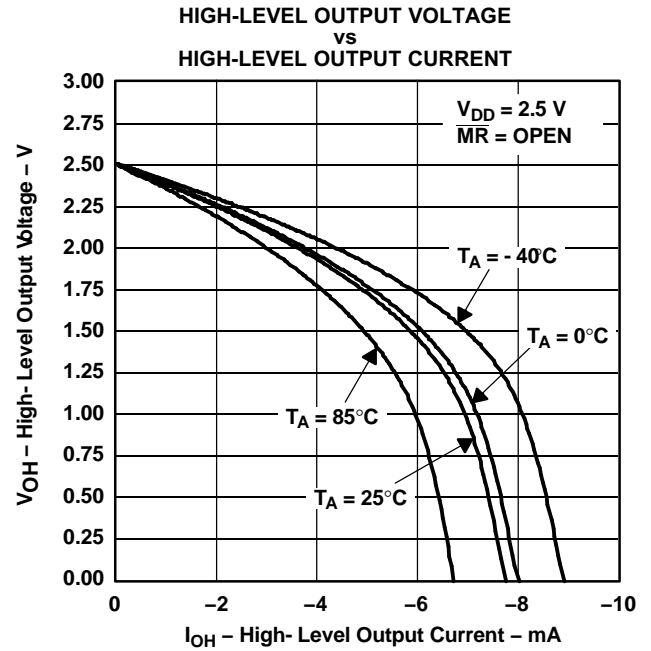

Figure 6.

**TYPICAL CHARACTERISTICS (continued)**

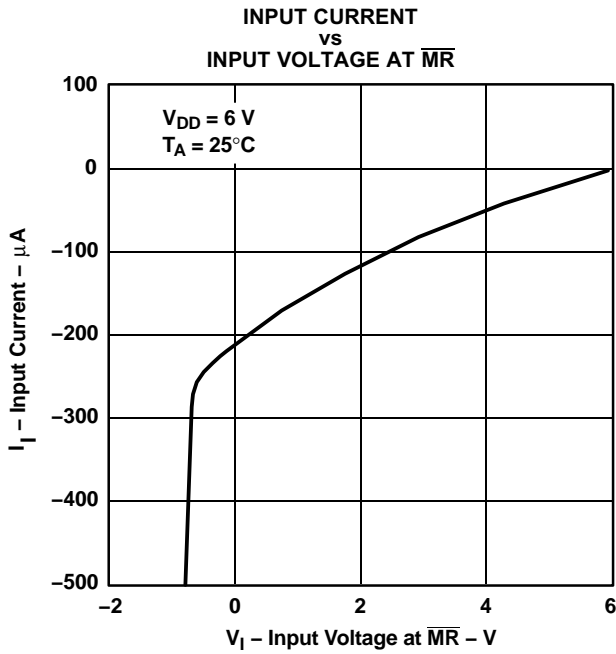

Figure 7.

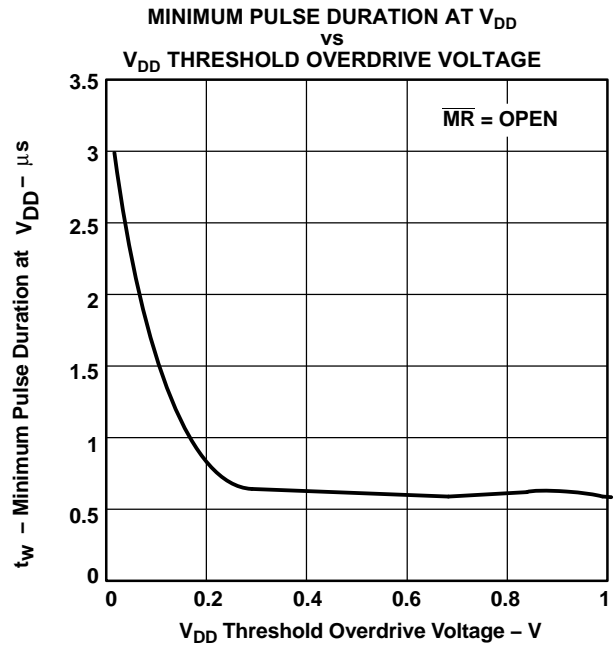

Figure 8.

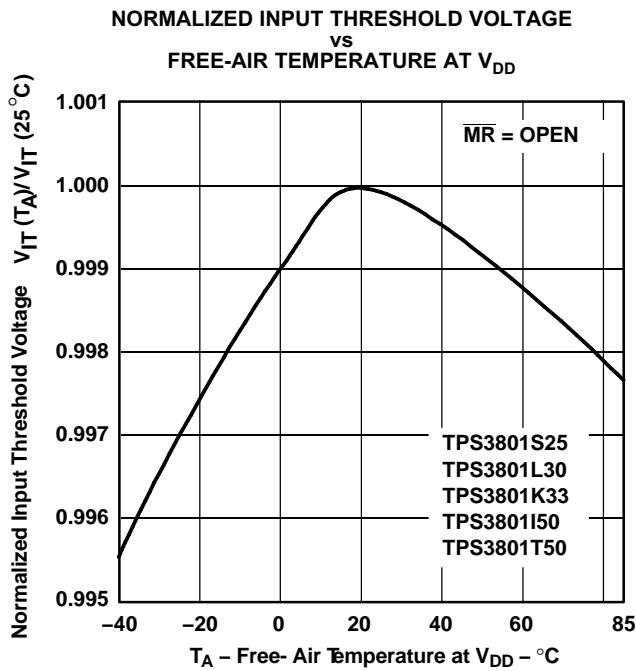

Figure 9.

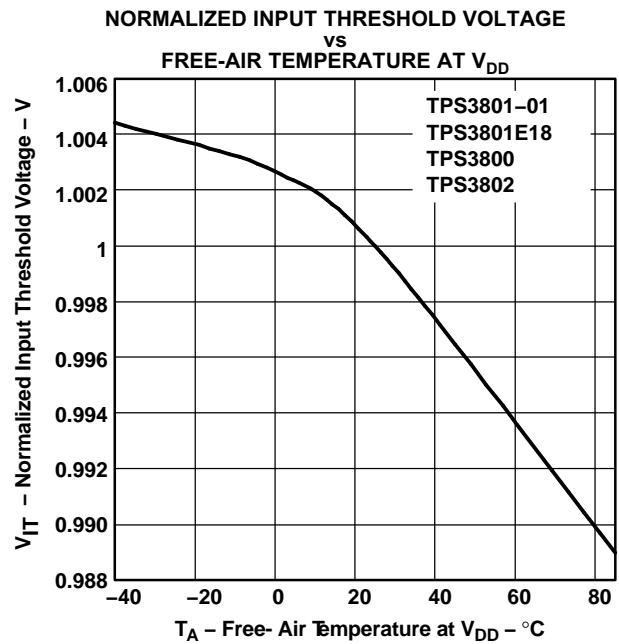

Figure 10.

**PACKAGING INFORMATION**

Orderable Device	Status <sup>(1)</sup>	Package Type	Package Drawing	Pins	Package Qty	Eco Plan <sup>(2)</sup>	Lead/Ball Finish	MSL Peak Temp <sup>(3)</sup>
TPS3800G27DCKR	ACTIVE	SC70	DCK	5	3000	Green (RoHS & no Sb/Br)	CU NIPDAU	Level-1-260C-UNLIM
TPS3800G27DCKRG4	ACTIVE	SC70	DCK	5	3000	Green (RoHS & no Sb/Br)	CU NIPDAU	Level-1-260C-UNLIM
TPS3801-01DCKR	ACTIVE	SC70	DCK	5	3000	Green (RoHS & no Sb/Br)	CU NIPDAU	Level-1-260C-UNLIM
TPS3801-01DCKRG4	ACTIVE	SC70	DCK	5	3000	Green (RoHS & no Sb/Br)	CU NIPDAU	Level-1-260C-UNLIM
TPS3801E18DCKR	ACTIVE	SC70	DCK	5	3000	Green (RoHS & no Sb/Br)	CU NIPDAU	Level-1-260C-UNLIM
TPS3801E18DCKRG4	ACTIVE	SC70	DCK	5	3000	Green (RoHS & no Sb/Br)	CU NIPDAU	Level-1-260C-UNLIM
TPS3801I50DCKR	ACTIVE	SC70	DCK	5	3000	Green (RoHS & no Sb/Br)	CU NIPDAU	Level-1-260C-UNLIM
TPS3801I50DCKRG4	ACTIVE	SC70	DCK	5	3000	Green (RoHS & no Sb/Br)	CU NIPDAU	Level-1-260C-UNLIM
TPS3801J25DCKR	ACTIVE	SC70	DCK	5	3000	Green (RoHS & no Sb/Br)	CU NIPDAU	Level-1-260C-UNLIM
TPS3801J25DCKRG4	ACTIVE	SC70	DCK	5	3000	Green (RoHS & no Sb/Br)	CU NIPDAU	Level-1-260C-UNLIM
TPS3801K33DCKR	ACTIVE	SC70	DCK	5	3000	Green (RoHS & no Sb/Br)	CU NIPDAU	Level-1-260C-UNLIM
TPS3801K33DCKRG4	ACTIVE	SC70	DCK	5	3000	Green (RoHS & no Sb/Br)	CU NIPDAU	Level-1-260C-UNLIM
TPS3801L30DCKR	ACTIVE	SC70	DCK	5	3000	Green (RoHS & no Sb/Br)	CU NIPDAU	Level-1-260C-UNLIM
TPS3801L30DCKRG4	ACTIVE	SC70	DCK	5	3000	Green (RoHS & no Sb/Br)	CU NIPDAU	Level-1-260C-UNLIM
TPS3801T50DCKR	ACTIVE	SC70	DCK	5	3000	Green (RoHS & no Sb/Br)	CU NIPDAU	Level-1-260C-UNLIM
TPS3801T50DCKRG4	ACTIVE	SC70	DCK	5	3000	Green (RoHS & no Sb/Br)	CU NIPDAU	Level-1-260C-UNLIM
TPS3801T50DCKT	OBSOLETE	SC70	DCK	5		TBD	Call TI	Call TI
TPS3802K33DCKR	ACTIVE	SC70	DCK	5	3000	Green (RoHS & no Sb/Br)	CU NIPDAU	Level-1-260C-UNLIM
TPS3802K33DCKRG4	ACTIVE	SC70	DCK	5	3000	Green (RoHS & no Sb/Br)	CU NIPDAU	Level-1-260C-UNLIM
TPS3802L30DCKR	ACTIVE	SC70	DCK	5	3000	Green (RoHS & no Sb/Br)	CU NIPDAU	Level-1-260C-UNLIM
TPS3802L30DCKRG4	ACTIVE	SC70	DCK	5	3000	Green (RoHS & no Sb/Br)	CU NIPDAU	Level-1-260C-UNLIM

<sup>(1)</sup> The marketing status values are defined as follows:

**ACTIVE:** Product device recommended for new designs.

**LIFEBUY:** TI has announced that the device will be discontinued, and a lifetime-buy period is in effect.

**NRND:** Not recommended for new designs. Device is in production to support existing customers, but TI does not recommend using this part in a new design.

**PREVIEW:** Device has been announced but is not in production. Samples may or may not be available.

**OBSOLETE:** TI has discontinued the production of the device.

<sup>(2)</sup> Eco Plan - The planned eco-friendly classification: Pb-Free (RoHS), Pb-Free (RoHS Exempt), or Green (RoHS & no Sb/Br) - please check

<http://www.ti.com/productcontent> for the latest availability information and additional product content details.

**TBD:** The Pb-Free/Green conversion plan has not been defined.

**Pb-Free (RoHS):** TI's terms "Lead-Free" or "Pb-Free" mean semiconductor products that are compatible with the current RoHS requirements for all 6 substances, including the requirement that lead not exceed 0.1% by weight in homogeneous materials. Where designed to be soldered at high temperatures, TI Pb-Free products are suitable for use in specified lead-free processes.

**Pb-Free (RoHS Exempt):** This component has a RoHS exemption for either 1) lead-based flip-chip solder bumps used between the die and package, or 2) lead-based die adhesive used between the die and leadframe. The component is otherwise considered Pb-Free (RoHS compatible) as defined above.

**Green (RoHS & no Sb/Br):** TI defines "Green" to mean Pb-Free (RoHS compatible), and free of Bromine (Br) and Antimony (Sb) based flame retardants (Br or Sb do not exceed 0.1% by weight in homogeneous material)

<sup>(3)</sup> MSL, Peak Temp. -- The Moisture Sensitivity Level rating according to the JEDEC industry standard classifications, and peak solder temperature.

**Important Information and Disclaimer:**The information provided on this page represents TI's knowledge and belief as of the date that it is provided. TI bases its knowledge and belief on information provided by third parties, and makes no representation or warranty as to the accuracy of such information. Efforts are underway to better integrate information from third parties. TI has taken and continues to take reasonable steps to provide representative and accurate information but may not have conducted destructive testing or chemical analysis on incoming materials and chemicals. TI and TI suppliers consider certain information to be proprietary, and thus CAS numbers and other limited information may not be available for release.

In no event shall TI's liability arising out of such information exceed the total purchase price of the TI part(s) at issue in this document sold by TI to Customer on an annual basis.

DCK (R-PDSO-G5)

PLASTIC SMALL-OUTLINE PACKAGE

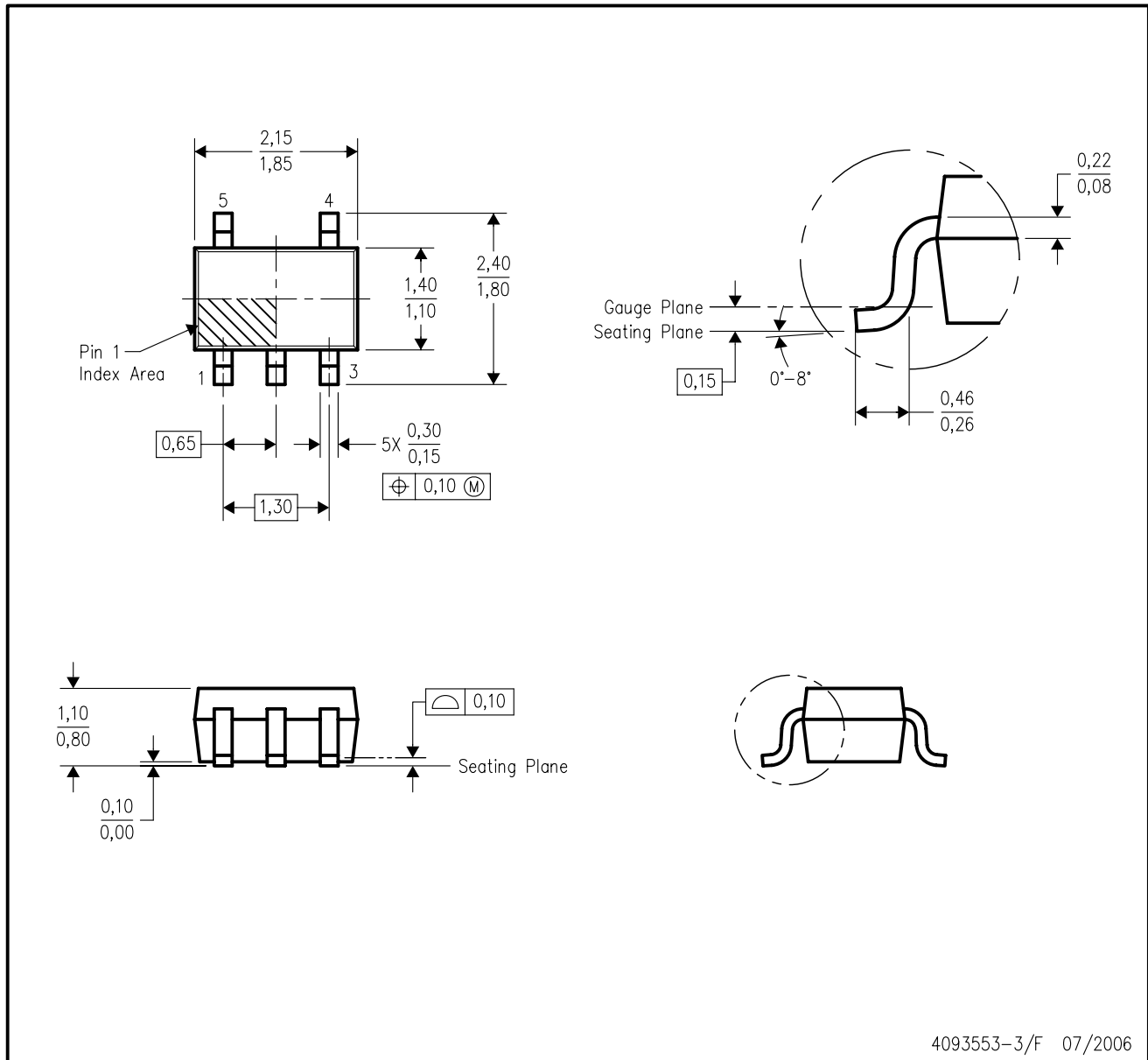

- NOTES:
- A. All linear dimensions are in millimeters.
  - B. This drawing is subject to change without notice.
  - C. Body dimensions do not include mold flash or protrusion. Mold flash and protrusion shall not exceed 0.15 per side.
  - D. Falls within JEDEC MO-203 variation AA.

## IMPORTANT NOTICE

Texas Instruments Incorporated and its subsidiaries (TI) reserve the right to make corrections, modifications, enhancements, improvements, and other changes to its products and services at any time and to discontinue any product or service without notice. Customers should obtain the latest relevant information before placing orders and should verify that such information is current and complete. All products are sold subject to TI's terms and conditions of sale supplied at the time of order acknowledgment.

TI warrants performance of its hardware products to the specifications applicable at the time of sale in accordance with TI's standard warranty. Testing and other quality control techniques are used to the extent TI deems necessary to support this warranty. Except where mandated by government requirements, testing of all parameters of each product is not necessarily performed.

TI assumes no liability for applications assistance or customer product design. Customers are responsible for their products and applications using TI components. To minimize the risks associated with customer products and applications, customers should provide adequate design and operating safeguards.

TI does not warrant or represent that any license, either express or implied, is granted under any TI patent right, copyright, mask work right, or other TI intellectual property right relating to any combination, machine, or process in which TI products or services are used. Information published by TI regarding third-party products or services does not constitute a license from TI to use such products or services or a warranty or endorsement thereof. Use of such information may require a license from a third party under the patents or other intellectual property of the third party, or a license from TI under the patents or other intellectual property of TI.

Reproduction of information in TI data books or data sheets is permissible only if reproduction is without alteration and is accompanied by all associated warranties, conditions, limitations, and notices. Reproduction of this information with alteration is an unfair and deceptive business practice. TI is not responsible or liable for such altered documentation.

Resale of TI products or services with statements different from or beyond the parameters stated by TI for that product or service voids all express and any implied warranties for the associated TI product or service and is an unfair and deceptive business practice. TI is not responsible or liable for any such statements.

Following are URLs where you can obtain information on other Texas Instruments products and application solutions:

<b>Products</b>		<b>Applications</b>	
Amplifiers	<a href="http://amplifier.ti.com">amplifier.ti.com</a>	Audio	<a href="http://www.ti.com/audio">www.ti.com/audio</a>
Data Converters	<a href="http://dataconverter.ti.com">dataconverter.ti.com</a>	Automotive	<a href="http://www.ti.com/automotive">www.ti.com/automotive</a>
DSP	<a href="http://dsp.ti.com">dsp.ti.com</a>	Broadband	<a href="http://www.ti.com/broadband">www.ti.com/broadband</a>
Interface	<a href="http://interface.ti.com">interface.ti.com</a>	Digital Control	<a href="http://www.ti.com/digitalcontrol">www.ti.com/digitalcontrol</a>
Logic	<a href="http://logic.ti.com">logic.ti.com</a>	Military	<a href="http://www.ti.com/military">www.ti.com/military</a>
Power Mgmt	<a href="http://power.ti.com">power.ti.com</a>	Optical Networking	<a href="http://www.ti.com/opticalnetwork">www.ti.com/opticalnetwork</a>
Microcontrollers	<a href="http://microcontroller.ti.com">microcontroller.ti.com</a>	Security	<a href="http://www.ti.com/security">www.ti.com/security</a>
Low Power Wireless	<a href="http://www.ti.com/lpw">www.ti.com/lpw</a>	Telephony	<a href="http://www.ti.com/telephony">www.ti.com/telephony</a>
		Video & Imaging	<a href="http://www.ti.com/video">www.ti.com/video</a>
		Wireless	<a href="http://www.ti.com/wireless">www.ti.com/wireless</a>

Mailing Address: Texas Instruments  
Post Office Box 655303 Dallas, Texas 75265

Copyright © 2006, Texas Instruments Incorporated