



SBOS141A – JANUARY 1984 – REVISED AUGUST 2003

PRECISION VOLTAGE-TO-CURRENT CONVERTER/TRANSMITTER

FEATURES

- 4mA TO 20mA TRANSMITTER
- SELECTABLE INPUT/OUTPUT RANGES:
0V to +5V, 0V to +10V Inputs
0mA to 20mA, 5mA to 25mA Outputs
Other Ranges
- 0.005% MAX NONLINEARITY, 14 BIT
- PRECISION +10V REFERENCE OUTPUT
- SINGLE SUPPLY OPERATION
- WIDE SUPPLY RANGE: 13.5V to 40V

DESCRIPTION

The XTR110 is a precision voltage-to-current converter designed for analog signal transmission. It accepts inputs of 0 to 5V or 0 to 10V and can be connected for outputs of 4 to 20mA, 0 to 20mA, 5 to 25mA and many other commonly used ranges.

A precision on-chip metal film resistor network provides input scaling and current offsetting. An internal 10V voltage reference can be used to drive external circuitry.

The XTR110 is available in 16-pin plastic DIP, ceramic DIP and SOL-16 surface-mount packages. Commercial and industrial temperature range models are available.

APPLICATIONS

- INDUSTRIAL PROCESS CONTROL
- PRESSURE/TEMPERATURE TRANSMITTERS
- CURRENT-MODE BRIDGE EXCITATION
- GROUNDING TRANSDUCER CIRCUITS
- CURRENT SOURCE REFERENCE FOR DATA ACQUISITION
- PROGRAMMABLE CURRENT SOURCE FOR TEST EQUIPMENT
- POWER PLANT/ENERGY SYSTEM MONITORING

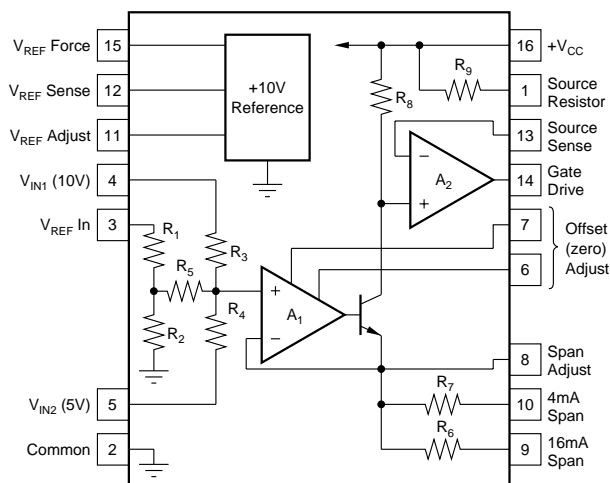

Please be aware that an important notice concerning availability, standard warranty, and use in critical applications of Texas Instruments semiconductor products and disclaimers thereto appears at the end of this data sheet.

All trademarks are the property of their respective owners.

PRODUCTION DATA information is current as of publication date. Products conform to specifications per the terms of Texas Instruments standard warranty. Production processing does not necessarily include testing of all parameters.

SPECIFICATIONS

ELECTRICAL

At $T_A = +25^\circ\text{C}$ and $V_{CC} = +24\text{V}$ and $R_L = 250\Omega^{**}$, unless otherwise specified.

PARAMETER	CONDITIONS	XTR110AG, KP, KU			XTR110BG			UNITS
		MIN	TYP	MAX	MIN	TYP	MAX	
TRANSMITTER								
Transfer Function			$I_O = 10 [(V_{REF}/16) + (V_{IN1}/4) + (V_{IN2}/2)] / R_{SPAN}$					
Input Range: $V_{IN1}^{(5)}$ V_{IN2}	Specified Performance	0		+10	*		*	V
	Specified Performance	0		+5	*		*	V
Current, I_O	Specified Performance ⁽¹⁾	4		20	*		*	mA
	Derated Performance ⁽¹⁾	0		40	*		*	mA
Nonlinearity	16mA/20mA Span ⁽²⁾		0.01	0.025		0.002	0.005	% of Span
Offset Current, I_{OS}	$I_O = 4\text{mA}^{(1)}$							
Initial	(1)		0.2	0.4		0.02	0.1	% of Span
vs Temperature	(1)		0.0003	0.005		*	0.003	% of Span/ $^\circ\text{C}$
vs Supply, V_{CC}	(1)		0.0005	0.005		*	*	% of Span/V
Span Error	$I_O = 20\text{mA}$							
Initial	(1)		0.3	0.6		0.05	0.2	% of Span
vs Temperature	(1)		0.0025	0.005		0.0009	0.003	% of Span/ $^\circ\text{C}$
vs Supply, V_{CC}	(1)		0.003	0.005		*	*	% of Span/V
Output Resistance	From Drain of FET (Q_{EXT}) ⁽³⁾		10×10^9			*	*	Ω
Input Resistance	V_{IN1}		27			*	*	k Ω
	V_{IN2}		22			*	*	k Ω
	V_{REF} In		19			*	*	k Ω
Dynamic Response								
Settling Time	To 0.1% of Span		15			*	*	μs
	To 0.01% of Span		20			*	*	μs
Slew Rate			1.3			*	*	mA/ μs
VOLTAGE REFERENCE								
Output Voltage		+9.95	+10	+10.05	+9.98	*	+10.02	V
vs Temperature			35	50		15	30	ppm/ $^\circ\text{C}$
vs Supply, V_{CC}	Line Regulation		0.0002	0.005		*	*	%/V
vs Output Current	Load Regulation		0.0005	0.01		*	*	%/mA
vs Time			100			*	*	ppm/1k hrs
Trim Range		-0.100		+0.25	*		*	V
Output Current	Specified Performance	10			*			mA
POWER SUPPLY								
Input Voltage, V_{CC}		+13.5		+40	*		*	V
Quiescent Current	Excluding I_O		3	4.5		*	*	mA
TEMPERATURE RANGE								
Specification: AG, BG		-40		+85	*		*	$^\circ\text{C}$
KP, KU		0		+70	*		*	$^\circ\text{C}$
Operating: AG, BG		-55		+125	*		*	$^\circ\text{C}$
KP, KU		-25		+85	*		*	$^\circ\text{C}$

* Specifications same as AG/KP grades. ** Specifications apply to the range of R_L shown in Typical Performance Curves.

NOTES: (1) Including internal reference. (2) Span is the change in output current resulting from a full-scale change in input voltage. (3) Within compliance range limited by $(+V_{CC} - 2V) + V_{DS}$ required for linear operation of the FET. (4) For V_{REF} adjustment circuit see Figure 3. (5) For extended I_{REF} drive circuit see Figure 4. (5) Unit may be damaged. See section, "Input Voltage Range".

ABSOLUTE MAXIMUM RATINGS

Power Supply, $+V_{CC}$	40V
Input Voltage, V_{IN1} , V_{IN2} , V_{REF} In	$+V_{CC}$
See text regarding safe negative input voltage range.	
Storage Temperature Range: A, B	-55°C to $+125^\circ\text{C}$
K, U	-40°C to $+85^\circ\text{C}$
Lead Temperature	
(soldering, 10s) G, P	300°C
(wave soldering, 3s) U	260°C
Output Short-Circuit Duration, Gate Drive	
and V_{REF} Force	Continuous to common and $+V_{CC}$
Output Current Using Internal 50Ω Resistor	40mA



ELECTROSTATIC DISCHARGE SENSITIVITY

This integrated circuit can be damaged by ESD. Texas Instruments recommends that all integrated circuits be handled with appropriate precautions. Failure to observe proper handling and installation procedures can cause damage.

ESD damage can range from subtle performance degradation to complete device failure. Precision integrated circuits may be more susceptible to damage because very small parametric changes could cause the device not to meet its published specifications.

PIN CONFIGURATION

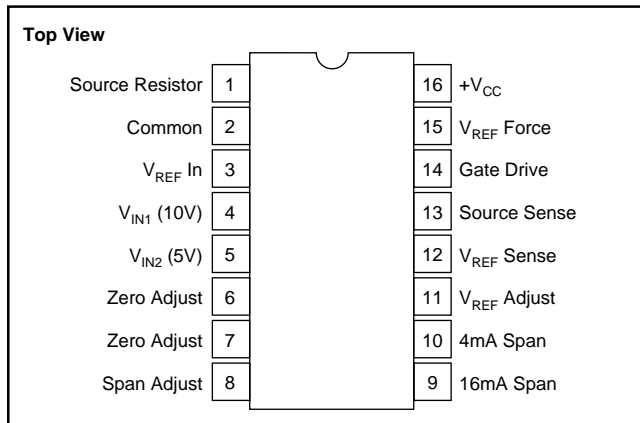

PACKAGE INFORMATION

PRODUCT	PACKAGE	PACKAGE DRAWING NUMBER ⁽¹⁾
XTR110AG	16-Pin Ceramic DIP	109
XTR110BG	16-Pin Ceramic DIP	109
XTR110KP	16-Pin Plastic DIP	180
XTR110KU	SOL-16 Surface-Mount	211

NOTE: (1) For detailed drawing and dimension table, please see end of data sheet, or Appendix C of Burr-Brown IC Data Book.

ORDERING INFORMATION

PRODUCT	PACKAGE	TEMPERATURE RANGE
XTR110AG	16-Pin Ceramic DIP	-40°C to +85°C
XTR110BG	16-Pin Ceramic DIP	-40°C to +85°C
XTR110KP	16-Pin Plastic DIP	0°C to +70°C
XTR110KU	SOL-16 Surface-Mount	0°C to +70°C

TYPICAL PERFORMANCE CURVES

T_A = +25°C, V_{CC} = 24VDC, R_L = 250Ω, unless otherwise noted.

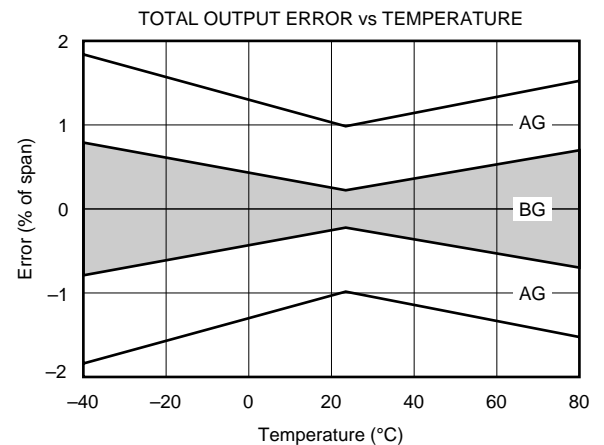
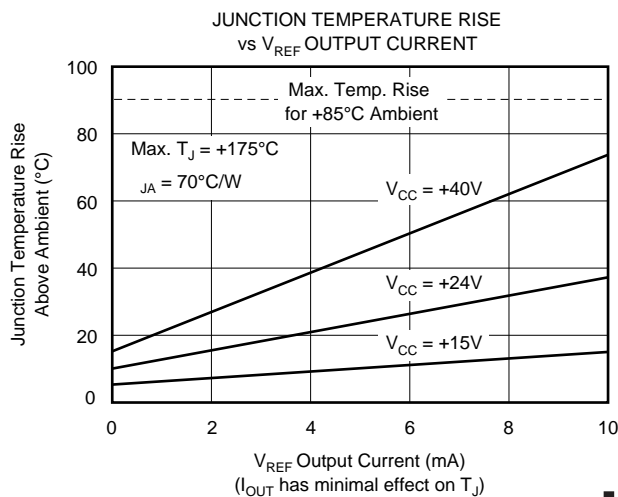
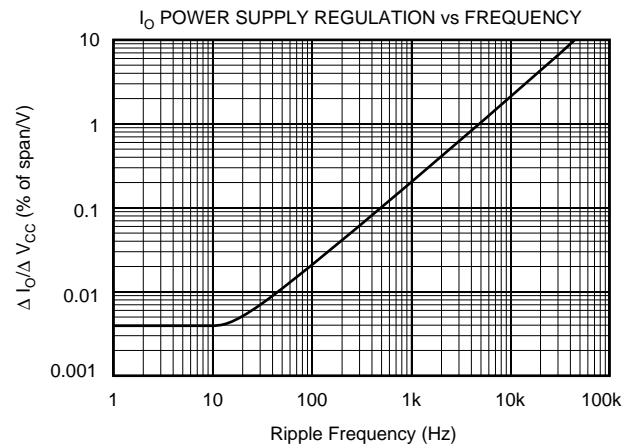
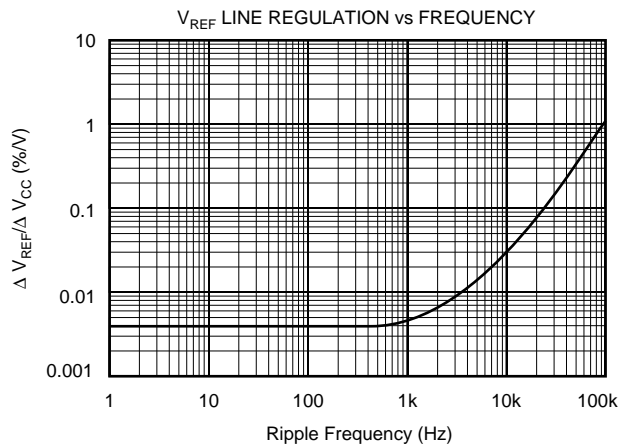

TYPICAL PERFORMANCE CURVES (CONT)

At $T_A = +25^\circ\text{C}$, $V_{CC} = 24\text{VDC}$, $R_L = 250\Omega$, unless otherwise noted.

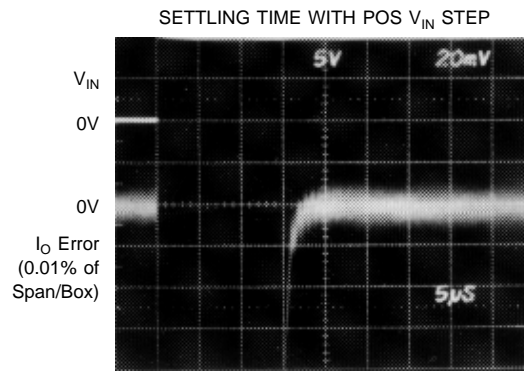
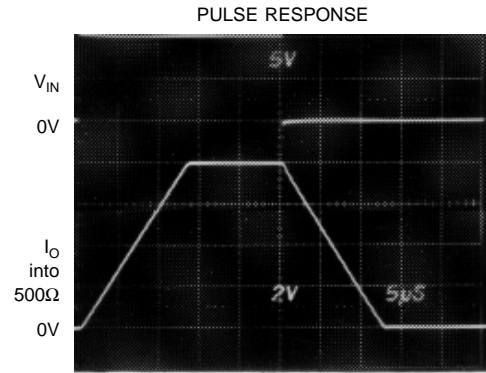
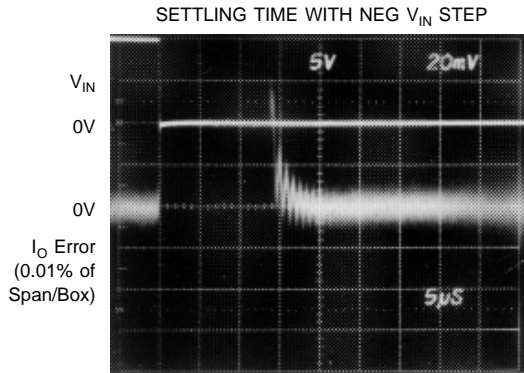
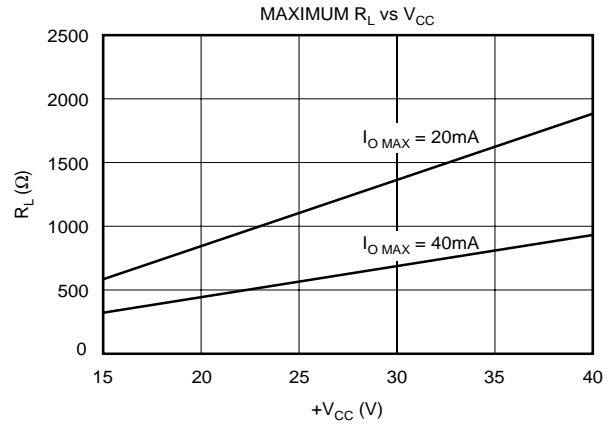
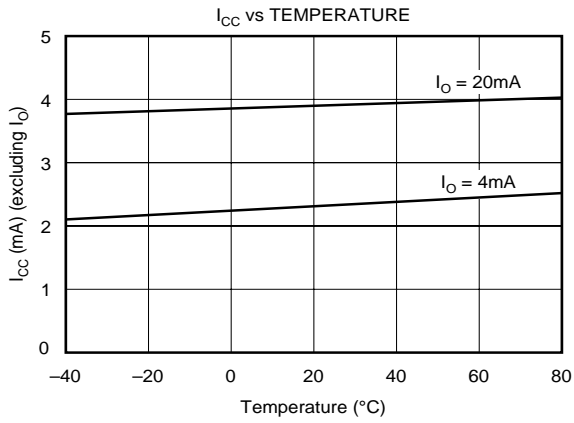

APPLICATIONS INFORMATION

Figure 1 shows the basic connections required for 0 to 10V input and 4 to 20mA output. Other input voltage and output current ranges require changes in connections of pins 3, 4, 5, 9 and 10 as shown in the table of Figure 1.

The complete transfer function of the XTR110 is:

$$I_O = \frac{10 \left[\frac{(V_{REF IN})}{16} + \frac{(V_{IN1})}{4} + \frac{(V_{IN2})}{2} \right]}{R_{SPAN}} \quad (1)$$

R_{SPAN} is the internal 50Ω resistor, R_9 , when connected as shown in Figure 1. An external R_{SPAN} can be connected for different output current ranges as described later.

EXTERNAL TRANSISTOR

An external pass transistor, Q_{EXT} , is required as shown in Figure 1. This transistor conducts the output signal current. A P-channel MOSFET transistor is recommended. It must have a voltage rating equal or greater than the maximum power supply voltage. Various recommended types are shown in Table I.

MANUFACTURER	PART NO.	BV _{DSS} ⁽¹⁾	BV _{GS} ⁽¹⁾	PACKAGE
Ferranti	ZVP1304A	40V	20V	TO-92
	ZVP1304B	40V	20V	TO-39
	ZVP1306A	60V	20V	TO-92
	ZVP1306B	60V	20V	TO-39
International Rectifier	IRF9513	60V	20V	TO-220
Motorola	MTP8P08	80V	20V	TO-220
RCA	RFL1P08	80V	20V	TO-39
	RFT2P08	80V	20V	TO-220
Siliconix (preferred)	VP0300B	30V	40V	TO-39
	VP0300L	30V	40V	TO-92
	VP0300M	30V	40V	TO-237
	VP0808B	80V	40V	TO-39
	VP0808L	80V	40V	TO-92
	VP0808M	80V	40V	TO-237
Supertex	VP1304N2	40V	20V	TO-220
	VP1304N3	40V	20V	TO-92
	VP1306N2	60V	20V	TO-220
	VP1306N3	60V	20V	TO-92

NOTE: (1) BV_{DSS}—Drain-source breakdown voltage. BV_{GS}—Gate-source breakdown voltage.

TABLE I. Available P-Channel MOSFETs.

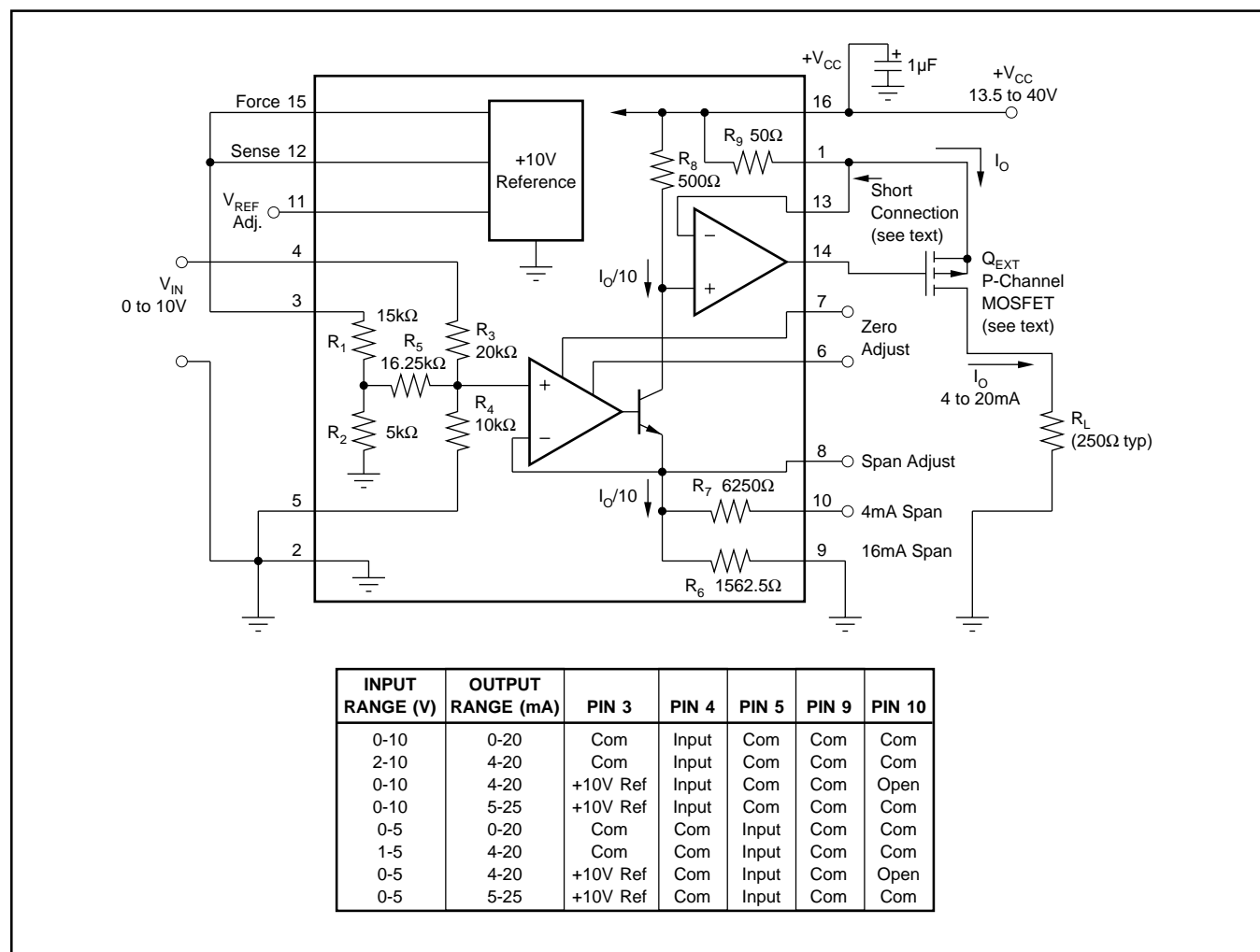

FIGURE 1. Basic Circuit Connection.

If the supply voltage, $+V_{CC}$, exceeds the gate-to-source breakdown voltage of Q_{EXT} , and the output connection (drain of Q_{EXT}) is broken, Q_{EXT} could fail. If the gate-to-source breakdown voltage is lower than $+V_{CC}$, Q_{EXT} can be protected with a 12V zener diode connected from gate to source.

Two PNP discrete transistors (Darlington-connected) can be used for Q_{EXT} —see Figure 2. Note that an additional capacitor is required for stability. Integrated Darlington transistors are not recommended because their internal base-emitter resistors cause excessive error.

TRANSISTOR DISSIPATION

Maximum power dissipation of Q_{EXT} depends on the power supply voltage and full-scale output current. Assuming that the load resistance is low, the power dissipated by Q_{EXT} is:

$$P_{MAX} = (+V_{CC}) I_{FS} \quad (2)$$

The transistor type and heat sinking must be chosen according to the maximum power dissipation to prevent overheating. See Table II for general recommendations.

PACKAGE TYPE	ALLOWABLE POWER DISSIPATION
TO-92	Lowest: Use minimum supply and at +25°C.
TO-237	Acceptable: Trade-off supply and temperature.
TO-39	Good: Adequate for majority of designs.
TO-220	Excellent: For prolonged maximum stress.
TO-3	Use if hermetic package is required.

TABLE II. External Transistor Package Type and Dissipation.

INPUT VOLTAGE RANGE

The internal op amp A_1 can be damaged if its non-inverting input (an internal node) is pulled more than 0.5V below common (0V). This could occur if input pins 3, 4 or 5 were driven with an op amp whose output could swing negative under abnormal conditions. The voltage at the input of A_1 is:

$$V_{A1} = \frac{(V_{REF IN})}{16} + \frac{(V_{IN1})}{4} + \frac{(V_{IN2})}{2} \quad (3)$$

This voltage should not be allowed to go more negative than $-0.5V$. If necessary, a clamp diode can be connected from the negative-going input to common to clamp the input voltage.

COMMON (Ground)

Careful attention should be directed toward proper connection of the common (grounds). All commons should be joined at one point as close to pin 2 of the XTR110 as possible. The exception is the I_{OUT} return. It can be returned to any point where it will not modulate the common at pin 2.

VOLTAGE REFERENCE

The reference voltage is accurately regulated at pin 12 ($V_{REF SENSE}$). To preserve accuracy, any load including pin

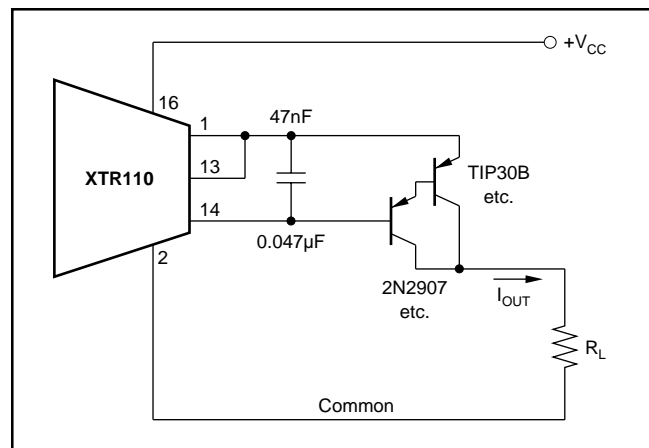
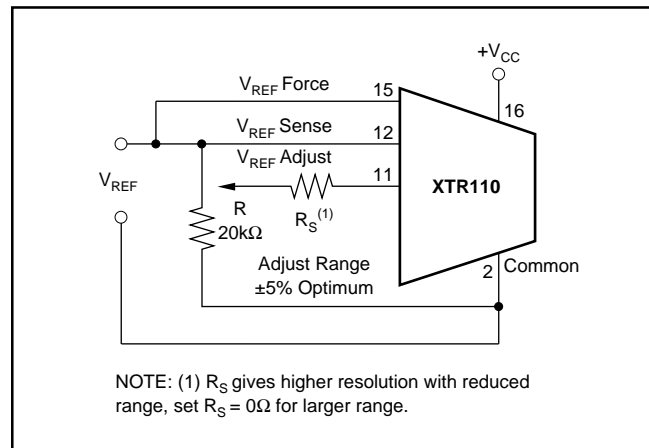
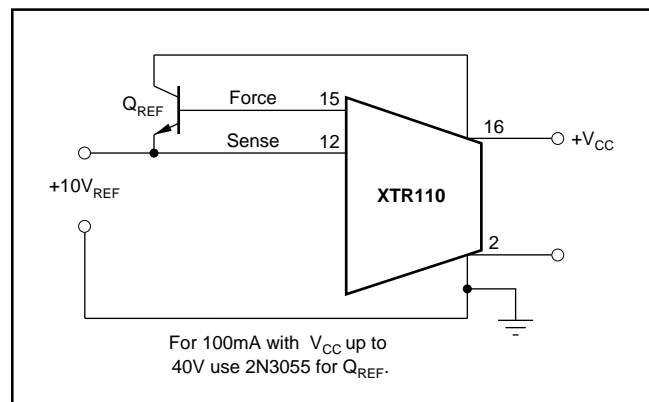

FIGURE 2. Q_{EXT} Using PNP Transistors.



NOTE: (1) R_S gives higher resolution with reduced range, set $R_S = 0\Omega$ for larger range.

FIGURE 3. Optional Adjustment of Reference Voltage.



For 100mA with V_{CC} up to 40V use 2N3055 for Q_{REF} .

FIGURE 4. Increasing Reference Current Drive.

3 should be connected to this point. The circuit in Figure 3 shows adjustment of the voltage reference.

The current drive capability of the XTR110's internal reference is 10mA. This can be extended if desired by adding an external NPN transistor shown in Figure 4.

OFFSET (ZERO) ADJUSTMENT

The offset current can be adjusted by using the potentiometer, R_1 , shown in Figure 5. Set the input voltage to zero and then adjust R_1 to give 4mA at the output. For spans starting

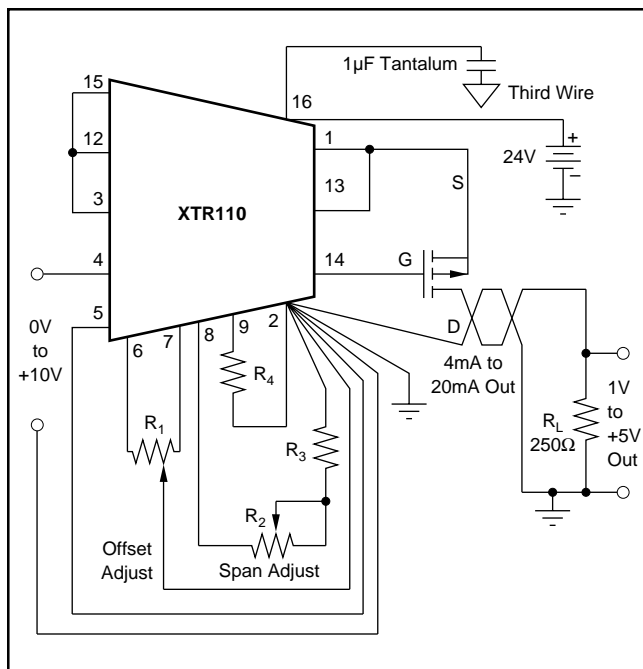

FIGURE 5. Offset and Span Adjustment Circuit for 0V to +10V Input, 4mA to 20mA Output.

at 0mA, the following special procedure is recommended: set the input to a small nonzero value and then adjust R_1 to the proper output current. When the input is zero the output will be zero. Figures 6 and 7 show graphically how offset is adjusted.

SPAN ADJUSTMENT

The span is adjusted at the full-scale output current using the potentiometer, R_2 , shown in Figure 5. This adjustment is interactive with the offset adjustment, and a few iterations may be necessary. For the circuit shown, set the input voltage to +10V full scale and adjust R_2 to give 20mA full-scale output. Figures 6 and 7 show graphically how span is adjusted.

The values of R_2 , R_3 , and R_4 for adjusting the span are determined as follows: choose R_4 in series to slightly decrease the span; then choose R_2 and R_3 to increase the span to be adjustable about the center value.

LOW TEMPERATURE COEFFICIENT OPERATION

Although the precision resistors in the XTR110 track within 1ppm/°C, the output current depends upon the absolute temperature coefficient (TC) of any one of the resistors, R_6 , R_7 , R_8 , and R_9 . Since the absolute TC of the output current can have 20ppm/°C, maximum, the TC of the output current can have 20ppm/°C drift. For low TC operation, zero TC resistors can be substituted for either the span resistors (R_6 or R_7) or for the source resistor (R_9) but not both.

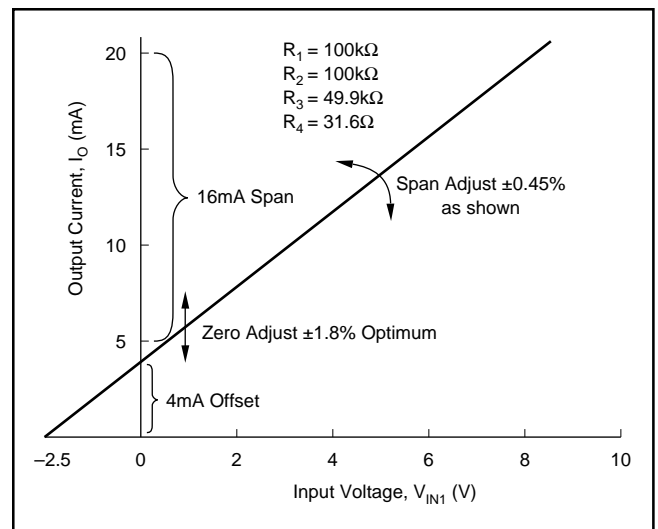

FIGURE 6. Zero and Span of 0V to +10V Input, 4mA to 20mA Output Configuration (see Figure 5).

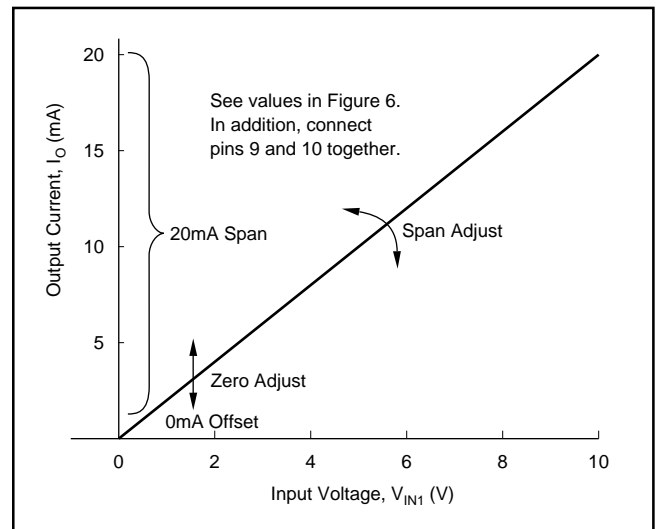

FIGURE 7. Zero and Span of 0V to +10V_{IN}, 0mA to 20mA Output Configuration (see Figure 5).

EXTENDED SPAN

For spans beyond 40mA, the internal 50Ω resistor (R_9) may be replaced by an external resistor connected between pins 13 and 16.

Its value can be calculated as follows:

$$R_{EXT} = R_9 (\text{Span}_{OLD} / \text{Span}_{NEW})$$

Since the internal thin-film resistors have a 20% absolute value tolerance, measure R_9 before determining the final value of R_{EXT} . Self-heating of R_{EXT} can cause nonlinearity. Therefore, choose one with a low TC and adequate power rating. See Figure 10 for application.

TYPICAL APPLICATIONS

The XTR110 is ideal for a variety of applications requiring high noise immunity current-mode signal transmission. The precision +10V reference can be used to excite bridges and transducers. Selectable ranges make it very useful as a precision programmable current source. The compact design

and low price of the XTR110 allow versatility with a minimum of external components and design engineering expense.

Figures 8 through 10 show typical applications of the XTR110.

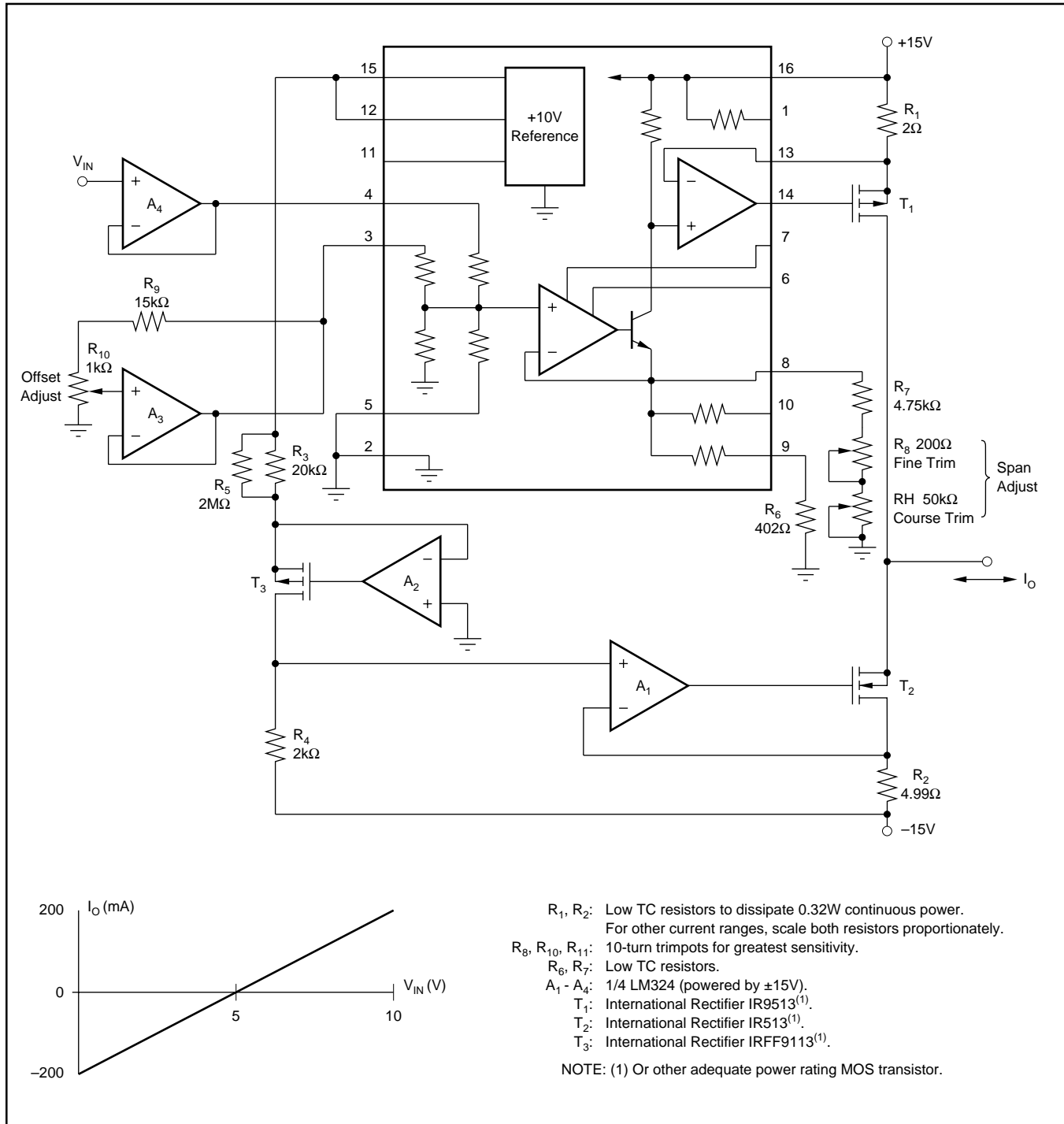

FIGURE 8. $\pm 200mA$ Current Pump.

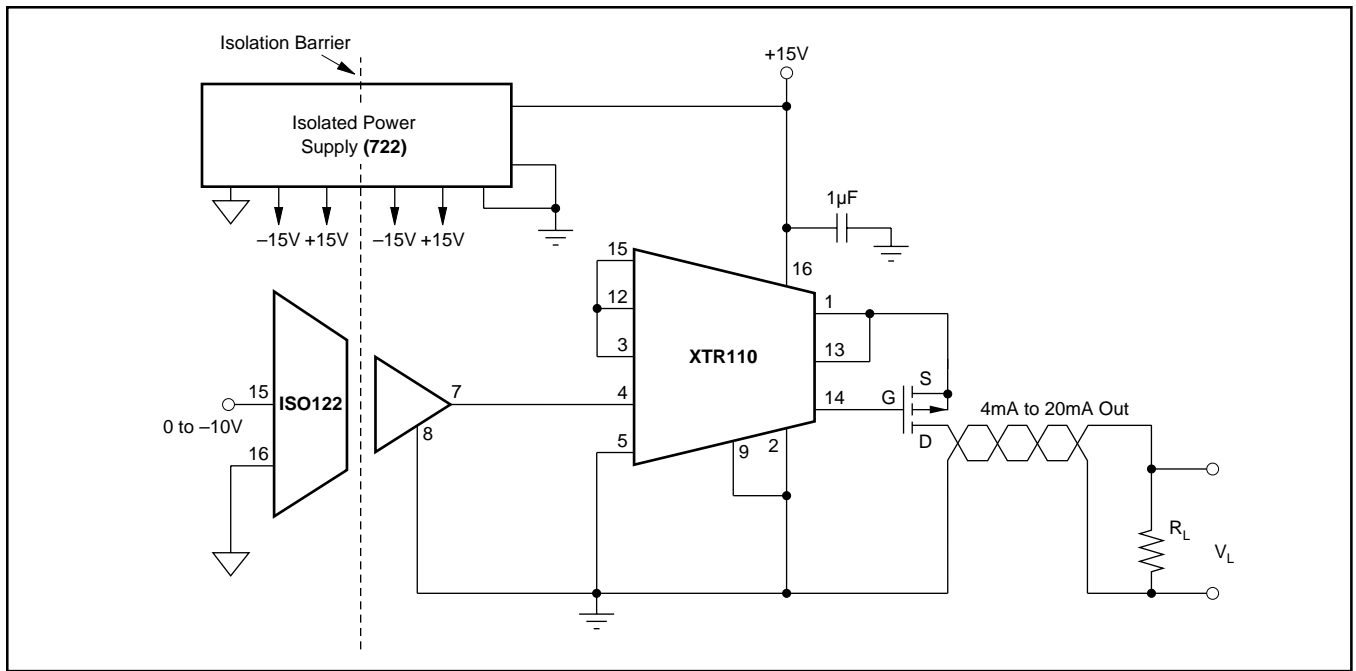

FIGURE 9. Isolated 4mA to 20mA Channel.

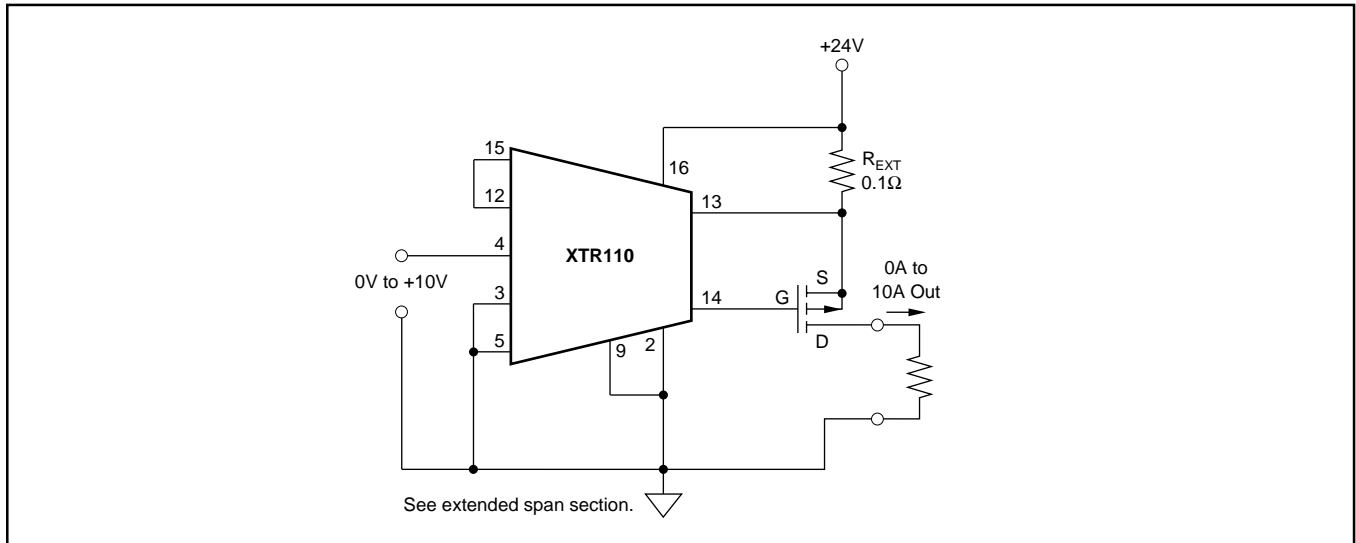
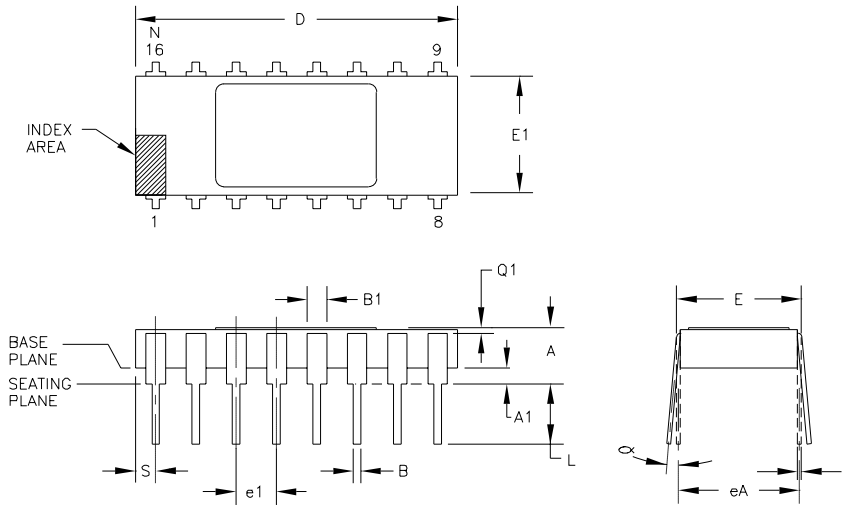

FIGURE 10. 0A to 10A Output Voltage-to-Current Converter.

PACKAGE DRAWINGS

Package Number 109 - 16-Lead, Ceramic Side Braze DIP, .300 Wide



DIM	INCHES		MILLIMETERS		NOTE
	MIN.	MAX.	MIN.	MAX.	
A	.105	.175	2.67	4.45	
A1	.025	.055	0.64	1.40	
B	.015	.021	0.38	0.53	5
B1	.038	.060	0.97	1.52	5
C	.008	.012	0.20	0.30	
D	.770	.830	19.56	21.08	
E	.290	.325	7.37	8.26	
E1	.280	.310	7.11	7.87	6
e1	.100 TYP.		2.54 TYP.		2
eA	.300 TYP.		7.62 TYP.		2
L	.125	.175	3.18	4.45	
N	16		16		4
Q1	.010	--	0.25	--	
S	.020	.065	0.51	1.65	

- NOTES:**
1. DIMENSIONING AND TOLERANCING PER ANSI Y14.5-1973.
 2. LEADS WITHIN .005 IN. (0.13mm) RADIUS OF TRUE POSITION (TP) AT GAUGE PLANE WITH MAXIMUM MATERIAL CONDITION AND UNIT INSTALLED.
 3. α APPLIES TO SPREAD LEADS PRIOR TO INSTALLATION.
 4. N IS THE NUMBER OF TERMINAL POSITIONS.

5. OUTLINES ON WHICH THE SEATING PLANE IS COINCIDENT WITH THE PLANE (A1 = 0), TERMINALS LEAD STANDOFFS ARE NOT REQUIRED, AND B1 MAY EQUAL B ALONG ANY PART OF THE LEAD ABOVE THE SEATING/BASE PLANE.
6. E1 DOES NOT INCLUDE PARTICLES OF PACKING MATERIALS.
7. CONTROLLING DIMENSION: INCH.
8. A VISUAL INDEX FEATURE MUST BE LOCATED WITHIN THE CROSS-HATCHED AREA.

PACKAGE NUMBER: ZZ109 REV.: D
JEDEC NUMBER: MO-36-AD

Package Number 180 - 16-Pin Plastic, Single-Wide DIP

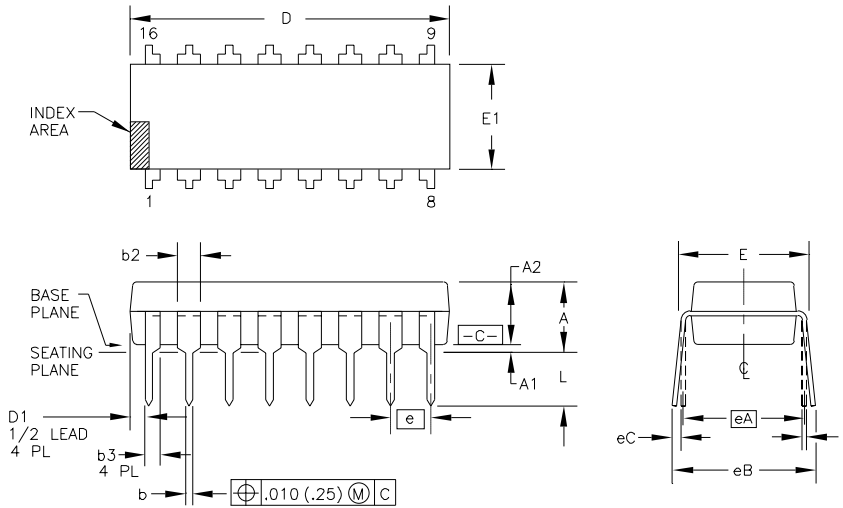

DIM	INCHES		MILLIMETERS		NOTE
	MIN.	MAX.	MIN.	MAX.	
A	--	.210	--	5.33	3
A1	.015	--	0.38	--	3
A2	.115	.195	2.92	4.95	
b	.014	.022	0.36	0.56	
b2	.045	.070	1.14	1.78	9
b3	.030	.045	0.76	1.14	9
c	.008	.014	0.20	0.36	
D	.735	.775	18.67	21.34	4
D1	.005	--	0.13	--	4
E	.300	.325	7.62	8.26	5
E1	.240	.280	6.10	7.11	4
e	.100 BASIC		2.54 BASIC		
eA	.300 BASIC		7.63 BASIC		5
eB	--	.430	--	10.92	6

- NOTES:**
1. ALL DIMENSIONS ARE IN INCHES.
 2. DIMENSIONING AND TOLERANCING PER ANSI Y14.5M-1982.
 3. DIMENSIONS A, A1, AND L ARE MEASURED WITH THE PACKAGE SEATED IN JEDEC SEATING PLANE GAUGE GS-3.
 4. D, D1, AND E1 DIMENSIONS DO NOT INCLUDE MOLD FLASH OR PROTRUSIONS. MOLD FLASH OR PROTRUSIONS SHALL NOT EXCEED .010 (0.25mm).
 5. E AND eA MEASURED WITH THE LEADS CONSTRAINED TO BE PERPENDICULAR TO DATUM \overline{C} .
 6. eB AND eC ARE MEASURED AT THE LEAD TIPS WITH THE LEADS UNCONSTRAINED.
 7. N IS THE MAXIMUM OF TERMINAL POSITIONS.

8. POINTED OR ROUNDED LEAD TIPS ARE PREFERRED TO EASE INSERTION.
9. b2 AND b3 MAXIMUM DIMENSIONS DO NOT INCLUDE DAMBAR PROTRUSIONS. DAMBAR PROTRUSIONS SHALL NOT EXCEED .010 (0.25mm).
10. DISTANCE BETWEEN LEADS INCLUDING DAMBAR PROTRUSIONS TO BE .005 (0.13mm) MINIMUM.
11. A VISUAL INDEX FEATURE MUST BE LOCATED WITHIN THE CROSS-HATCHED AREA.
12. FOR AUTOMATIC INSERTION, ANY RAISED IRREGULARITY ON THE TOP SURFACE (STEP, MESA, ETC.) SHALL BE SYMMETRICAL ABOUT THE LATERAL AND LONGITUDINAL PACKAGE CENTERLINES.

PACKAGE NUMBER: ZZ180 REV.: F
JEDEC NUMBER: MS-001-BB

PACKAGE DRAWINGS (CONT)

Package Number 211 - 16-Lead SOIC, .300 Wide

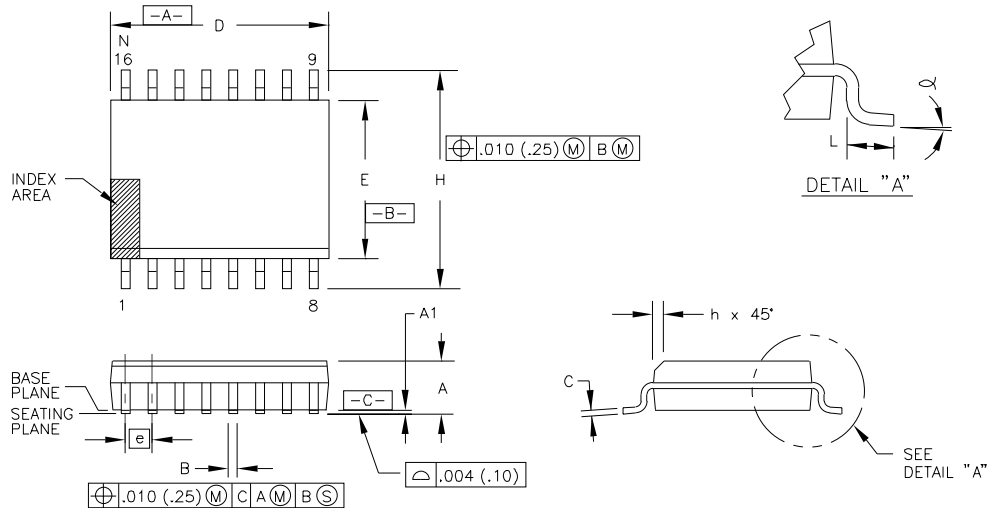

DIM	INCHES		MILLIMETERS		N	E	DIM	INCHES		MILLIMETERS		N	E	NOTES:
	MIN.	MAX.	MIN.	MAX.				MIN.	MAX.	MIN.	MAX.			
A	.0926	.1043	2.35	2.65										<p>1. DIMENSIONING AND TOLERANCING PER ANSI Y14.5M-1982.</p> <p>2. DIMENSION D DOES NOT INCLUDE MOLD FLASH, PROTRUSIONS OR GATE BURRS. MOLD FLASH, PROTRUSIONS AND GATE BURRS SHALL NOT EXCEED .006 IN. (0.15 mm) PER SIDE.</p> <p>3. DIMENSION E DOES NOT INCLUDE INTER-LEAD FLASH OR PROTRUSIONS. INTER-LEAD FLASH AND PROTRUSIONS SHALL NOT EXCEED .010 IN. (0.25 mm) PER SIDE.</p> <p>4. THE CHAMFER ON THE BODY IS OPTIONAL. IF IT IS NOT PRESENT,</p>
A1	.004	.0118	0.10	0.30									<p>5. L IS THE LENGTH OF TERMINAL FOR SOLDERING TO A SUBSTRATE.</p> <p>6. N IS THE NUMBER OF TERMINAL POSITIONS.</p> <p>7. THE LEAD WIDTH B, AS MEASURED .014 IN. (0.36 mm) OR GREATER ABOVE THE SEATING PLANE, SHALL NOT EXCEED A MAXIMUM VALUE OF .024 IN. (0.61 mm).</p> <p>8. LEAD TO LEAD COPLANARITY SHALL BE LESS THAN .004 IN. (0.10 mm) FROM SEATING PLANE.</p>	
B	.013	.020	0.33	0.51	7									
C	.0091	.0125	0.23	0.32										
D	.3977	.4133	10.10	10.50	2									
E	.2914	.2992	7.40	7.60	3									
e	.050 BASIC		1.27 BASIC											
H	.394	.419	10.00	10.65										
h	.010	.029	0.25	0.75	4									
L	.016	.050	0.40	1.27	5									
N		16		16	6									
alpha	0°	8°	0°	8°										

PACKAGE NUMBER: ZZ211 REV.: F
JEDEC NUMBER: MS-013-AA

PACKAGING INFORMATION

Orderable Device	Status ⁽¹⁾	Package Type	Package Drawing	Pins	Package Qty	Eco Plan ⁽²⁾	Lead/Ball Finish	MSL Peak Temp ⁽³⁾
XTR110AD	OBSOLETE	XCEPT	Y	0		TBD	Call TI	Call TI
XTR110AG	NRND	CDIP SB	JD	16	24	Green (RoHS & no Sb/Br)	Call TI	N / A for Pkg Type
XTR110BG	NRND	CDIP SB	JD	16	24	Green (RoHS & no Sb/Br)	Call TI	N / A for Pkg Type
XTR110KP	ACTIVE	PDIP	N	16	25	TBD	CU NIPDAU	N / A for Pkg Type
XTR110KU	ACTIVE	SOIC	DW	16	48	TBD	CU NIPDAU	Level-2-220C-1 YEAR
XTR110KU/1K	ACTIVE	SOIC	DW	16	1000	TBD	CU NIPDAU	Level-2-220C-1 YEAR

⁽¹⁾ The marketing status values are defined as follows:

ACTIVE: Product device recommended for new designs.

LIFEBUY: TI has announced that the device will be discontinued, and a lifetime-buy period is in effect.

NRND: Not recommended for new designs. Device is in production to support existing customers, but TI does not recommend using this part in a new design.

PREVIEW: Device has been announced but is not in production. Samples may or may not be available.

OBSOLETE: TI has discontinued the production of the device.

⁽²⁾ Eco Plan - The planned eco-friendly classification: Pb-Free (RoHS), Pb-Free (RoHS Exempt), or Green (RoHS & no Sb/Br) - please check <http://www.ti.com/productcontent> for the latest availability information and additional product content details.

TBD: The Pb-Free/Green conversion plan has not been defined.

Pb-Free (RoHS): TI's terms "Lead-Free" or "Pb-Free" mean semiconductor products that are compatible with the current RoHS requirements for all 6 substances, including the requirement that lead not exceed 0.1% by weight in homogeneous materials. Where designed to be soldered at high temperatures, TI Pb-Free products are suitable for use in specified lead-free processes.

Pb-Free (RoHS Exempt): This component has a RoHS exemption for either 1) lead-based flip-chip solder bumps used between the die and package, or 2) lead-based die adhesive used between the die and leadframe. The component is otherwise considered Pb-Free (RoHS compatible) as defined above.

Green (RoHS & no Sb/Br): TI defines "Green" to mean Pb-Free (RoHS compatible), and free of Bromine (Br) and Antimony (Sb) based flame retardants (Br or Sb do not exceed 0.1% by weight in homogeneous material)

⁽³⁾ MSL, Peak Temp. -- The Moisture Sensitivity Level rating according to the JEDEC industry standard classifications, and peak solder temperature.

Important Information and Disclaimer:The information provided on this page represents TI's knowledge and belief as of the date that it is provided. TI bases its knowledge and belief on information provided by third parties, and makes no representation or warranty as to the accuracy of such information. Efforts are underway to better integrate information from third parties. TI has taken and continues to take reasonable steps to provide representative and accurate information but may not have conducted destructive testing or chemical analysis on incoming materials and chemicals. TI and TI suppliers consider certain information to be proprietary, and thus CAS numbers and other limited information may not be available for release.

In no event shall TI's liability arising out of such information exceed the total purchase price of the TI part(s) at issue in this document sold by TI to Customer on an annual basis.

JD (R-CDIP-T**)

CERAMIC SIDE-BRAZE DUAL-IN-LINE PACKAGE

20 PINS SHOWN

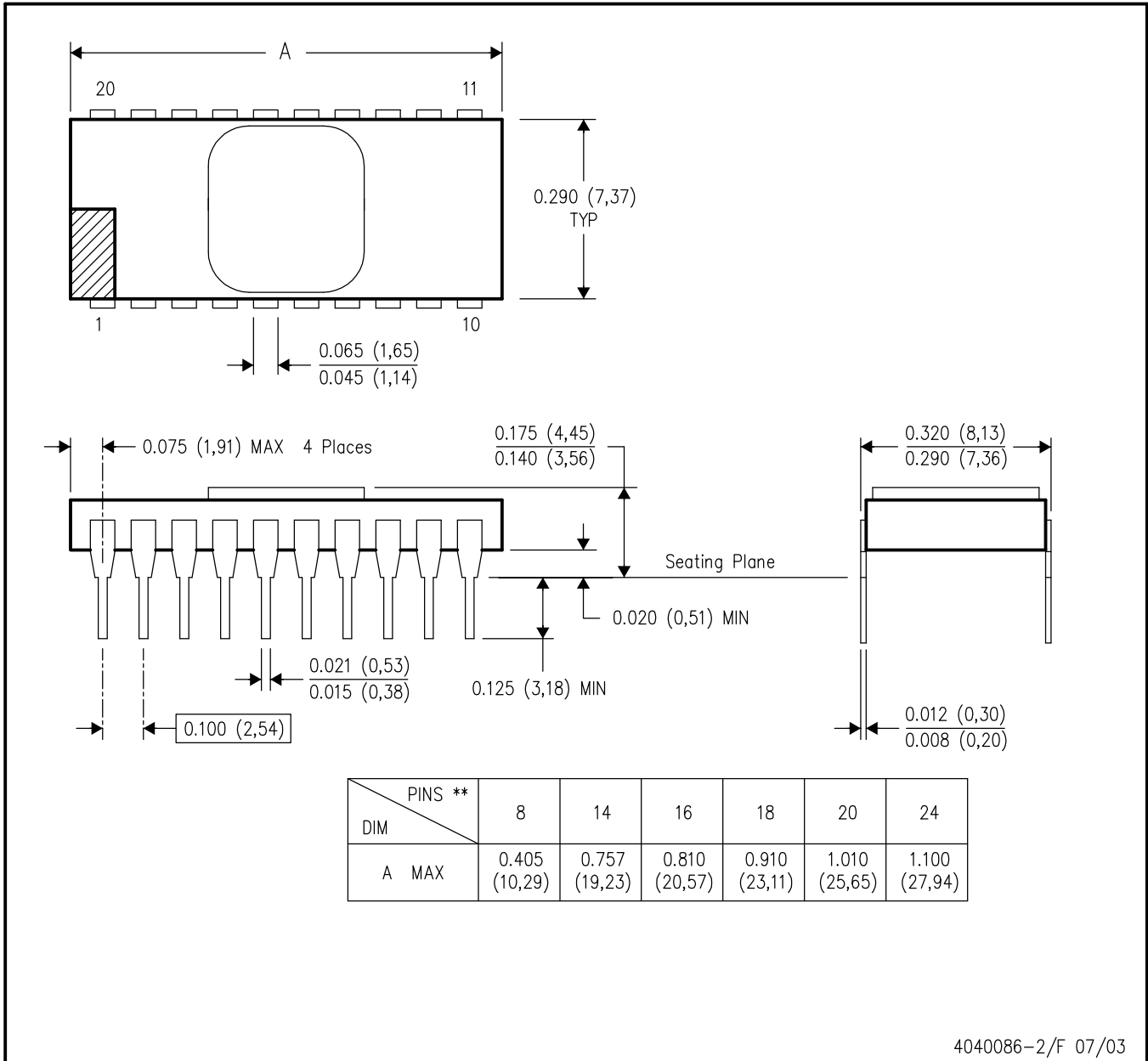

4040086-2/F 07/03



- NOTES:
- A. All linear dimensions are in inches (millimeters).
 - B. This drawing is subject to change without notice.
 - C. This package is hermetically sealed with a metal lid.
 - D. The terminals are gold plated.
 - E. Falls within MIL STD 1835 CDIP2 - T8, T14, T16, T18, T20 and T24 respectively.

N (R-PDIP-T**)

PLASTIC DUAL-IN-LINE PACKAGE

16 PINS SHOWN



- NOTES:
- A. All linear dimensions are in inches (millimeters).
 - B. This drawing is subject to change without notice.
 -  Falls within JEDEC MS-001, except 18 and 20 pin minimum body length (Dim A).
 -  The 20 pin end lead shoulder width is a vendor option, either half or full width.

DW (R-PDSO-G16)

PLASTIC SMALL-OUTLINE PACKAGE

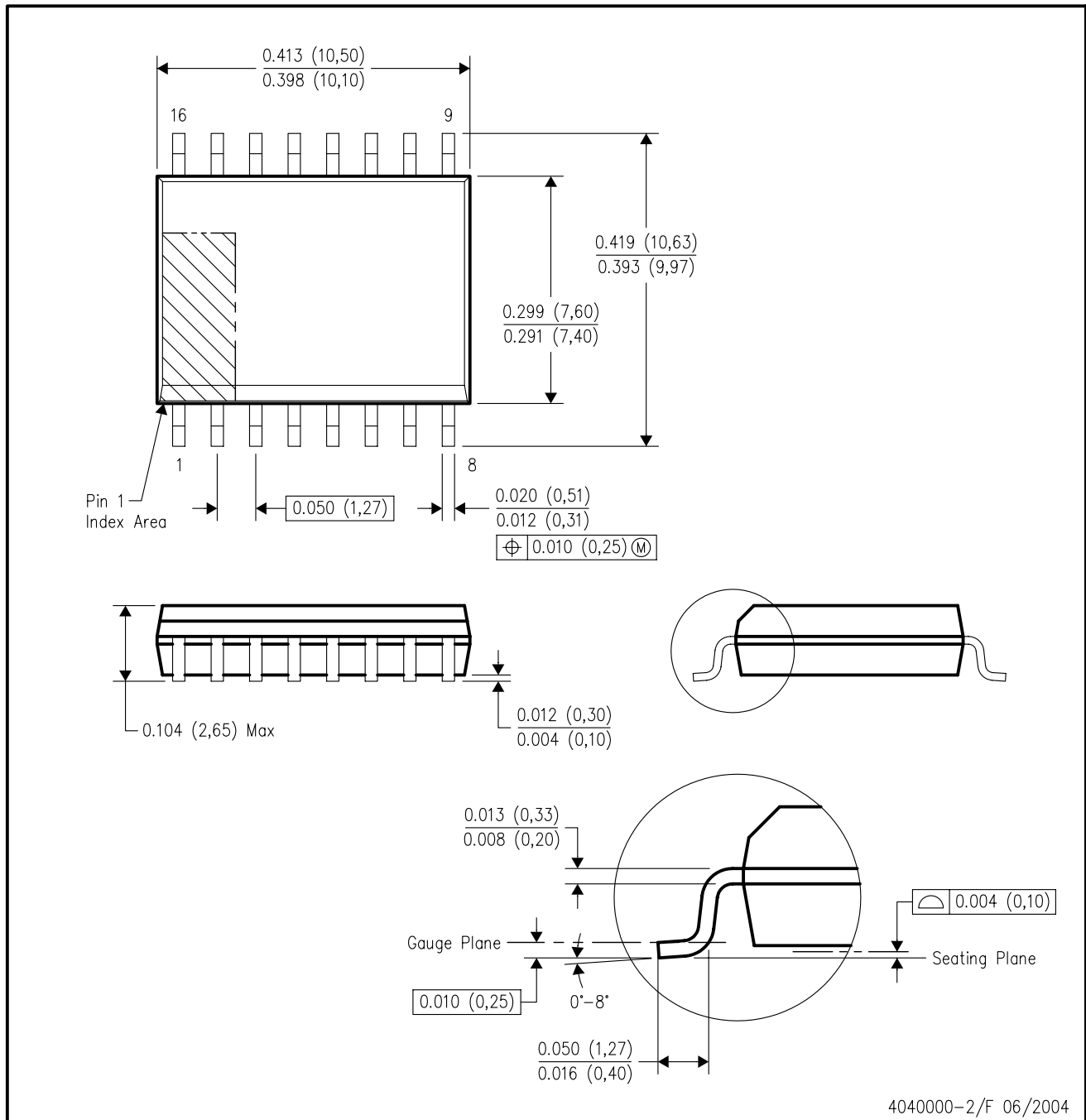

- NOTES:
- A. All linear dimensions are in inches (millimeters).
 - B. This drawing is subject to change without notice.
 - C. Body dimensions do not include mold flash or protrusion not to exceed 0.006 (0,15).
 - D. Falls within JEDEC MS-013 variation AA.

IMPORTANT NOTICE

Texas Instruments Incorporated and its subsidiaries (TI) reserve the right to make corrections, modifications, enhancements, improvements, and other changes to its products and services at any time and to discontinue any product or service without notice. Customers should obtain the latest relevant information before placing orders and should verify that such information is current and complete. All products are sold subject to TI's terms and conditions of sale supplied at the time of order acknowledgment.

TI warrants performance of its hardware products to the specifications applicable at the time of sale in accordance with TI's standard warranty. Testing and other quality control techniques are used to the extent TI deems necessary to support this warranty. Except where mandated by government requirements, testing of all parameters of each product is not necessarily performed.

TI assumes no liability for applications assistance or customer product design. Customers are responsible for their products and applications using TI components. To minimize the risks associated with customer products and applications, customers should provide adequate design and operating safeguards.

TI does not warrant or represent that any license, either express or implied, is granted under any TI patent right, copyright, mask work right, or other TI intellectual property right relating to any combination, machine, or process in which TI products or services are used. Information published by TI regarding third-party products or services does not constitute a license from TI to use such products or services or a warranty or endorsement thereof. Use of such information may require a license from a third party under the patents or other intellectual property of the third party, or a license from TI under the patents or other intellectual property of TI.

Reproduction of information in TI data books or data sheets is permissible only if reproduction is without alteration and is accompanied by all associated warranties, conditions, limitations, and notices. Reproduction of this information with alteration is an unfair and deceptive business practice. TI is not responsible or liable for such altered documentation.

Resale of TI products or services with statements different from or beyond the parameters stated by TI for that product or service voids all express and any implied warranties for the associated TI product or service and is an unfair and deceptive business practice. TI is not responsible or liable for any such statements.

Following are URLs where you can obtain information on other Texas Instruments products and application solutions:

Products		Applications	
Amplifiers	amplifier.ti.com	Audio	www.ti.com/audio
Data Converters	dataconverter.ti.com	Automotive	www.ti.com/automotive
DSP	dsp.ti.com	Broadband	www.ti.com/broadband
Interface	interface.ti.com	Digital Control	www.ti.com/digitalcontrol
Logic	logic.ti.com	Military	www.ti.com/military
Power Mgmt	power.ti.com	Optical Networking	www.ti.com/opticalnetwork
Microcontrollers	microcontroller.ti.com	Security	www.ti.com/security
		Telephony	www.ti.com/telephony
		Video & Imaging	www.ti.com/video
		Wireless	www.ti.com/wireless

Mailing Address: Texas Instruments
Post Office Box 655303 Dallas, Texas 75265

Copyright © 2006, Texas Instruments Incorporated