

8

7

6

5

4

3

2

1

DO NOT SCALE DRAWING

THE INFORMATION CONTAINED HEREIN IS THE EXCLUSIVE PROPERTY OF VIRGINIA PANEL CORPORATION AND IS SUBMITTED FOR USE BY THE CUSTOMER ONLY. THE DATA SHALL NOT BE DUPLICATED, USED OR DISCLOSED IN WHOLE OR IN PART FOR ANY PURPOSE OTHER THAN TO MAINTAIN THE EQUIPMENT PROVIDED. CONSULT WITH VIRGINIA PANEL CORPORATION ENGINEERING IF MORE DETAIL IS REQUIRED.

REVISIONS			
REV	DESCRIPTION	DATE	ENGR
A	DRAWING ORIGINATION - ECN #5907	3/30/15	R GARMAN

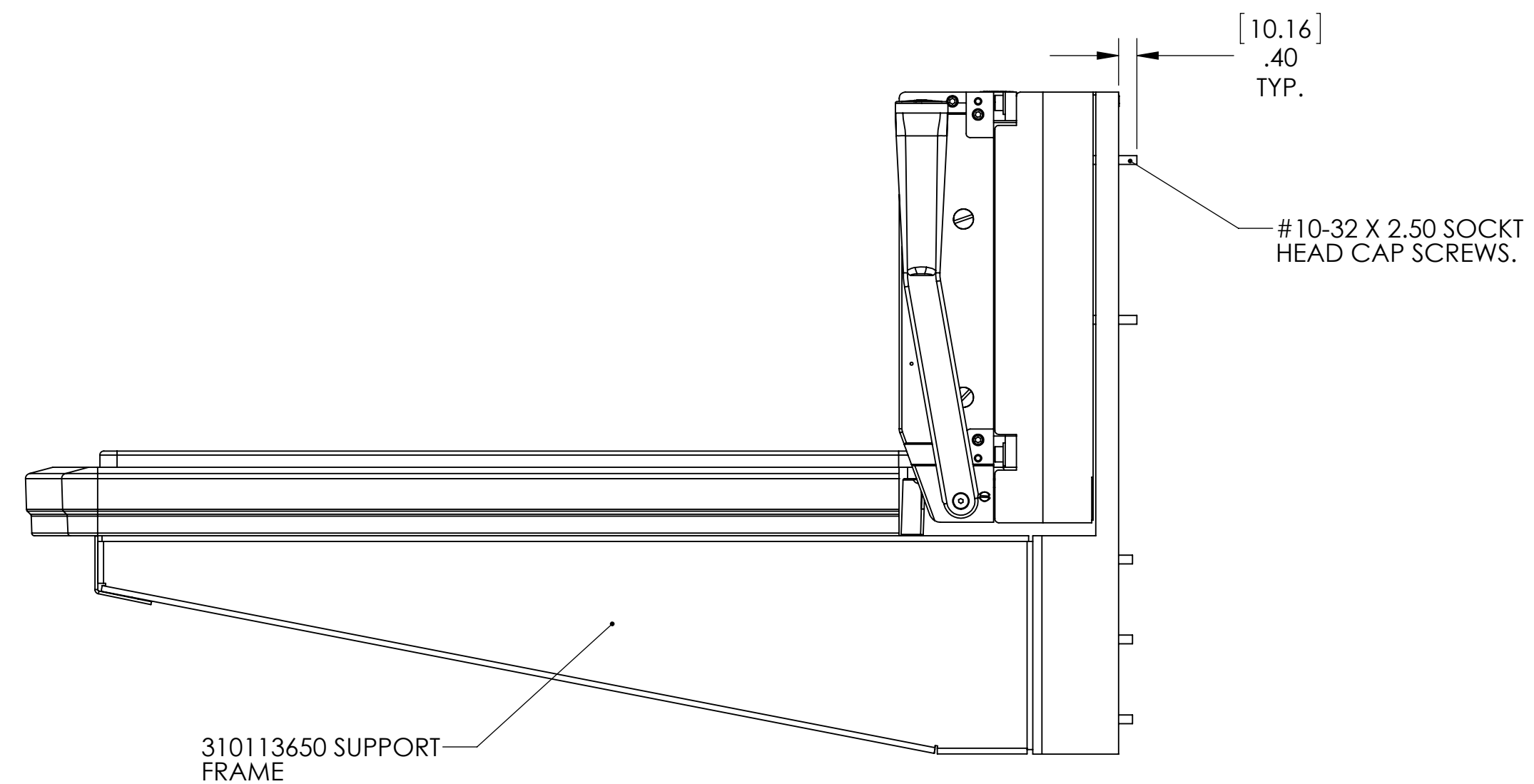
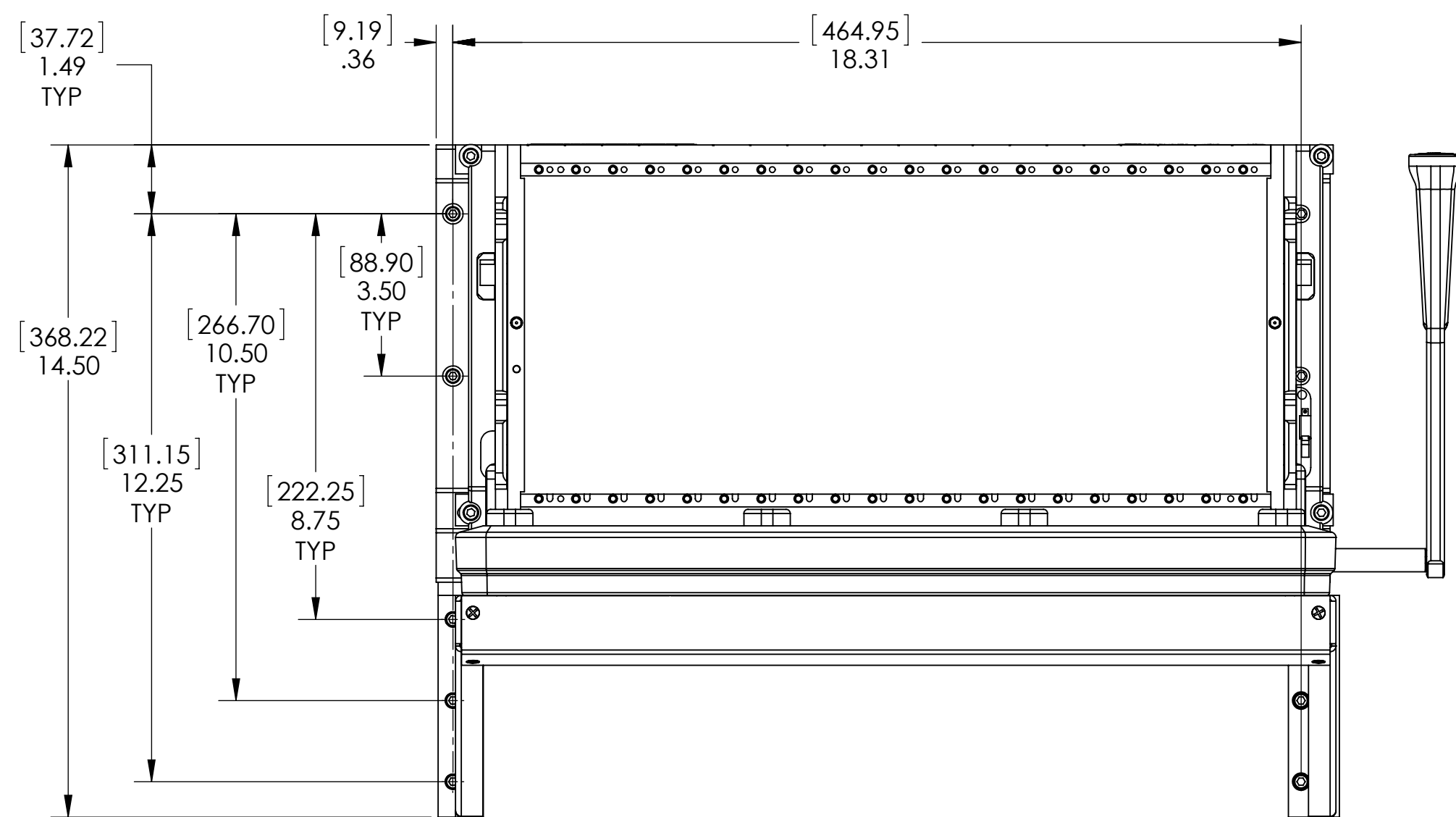
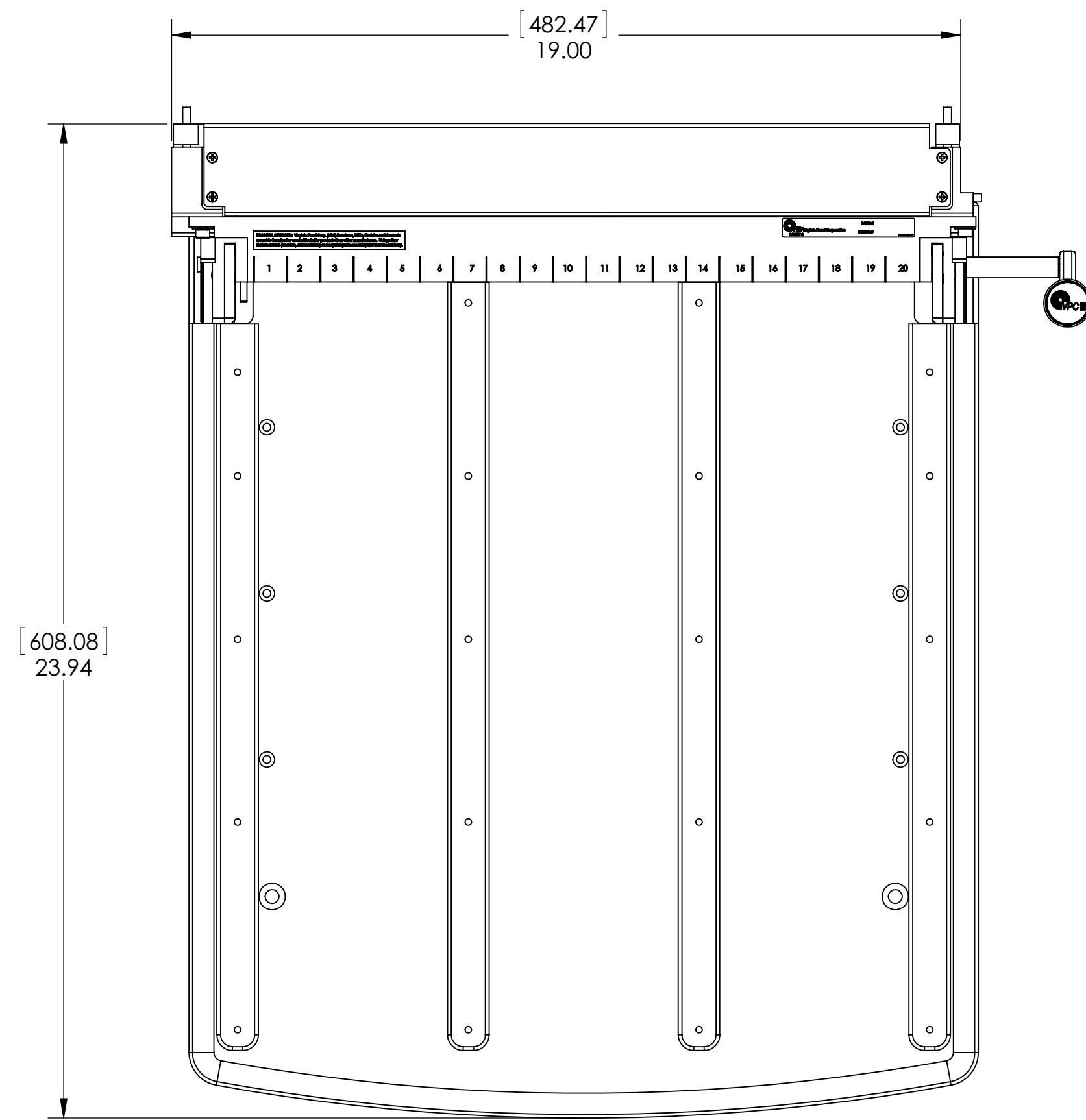

- NOTES:
1. FOR APPLICATION USE AND CARE INFORMATION CONSULT VPC USERS GUIDE @ WWW.VPC.COM
 2. CHASSIS FLANGE KIT INCLUDED BUT NOT SHOWN.
 3. TO ASSEMBLE, SEE SHEET 2 OF CUSOTMER DRAWING.

CUSTOMER DRAWING			
VIRGINIA PANEL CORPORATION WWW.VPC.COM			
G20 Rcvr, Fixed Rack Mnt For 40-923 Chassis			
RELATIVE CONNECTOR POSITIONS AND WIRE ROUTING ARE GENERIC AND MAY VARY WITH PRODUCT.	SIZE: D	CAGE CODE: 18117	DWG. NO.: 310120195
DIMENSIONS ARE SHOWN AS: [MILLIMETERS] INCHES	SCALE: 1:4	310120195	3/30/15 SHEET 1 OF 3

8

7

6

5

4

3

2

1

DO NOT SCALE DRAWING

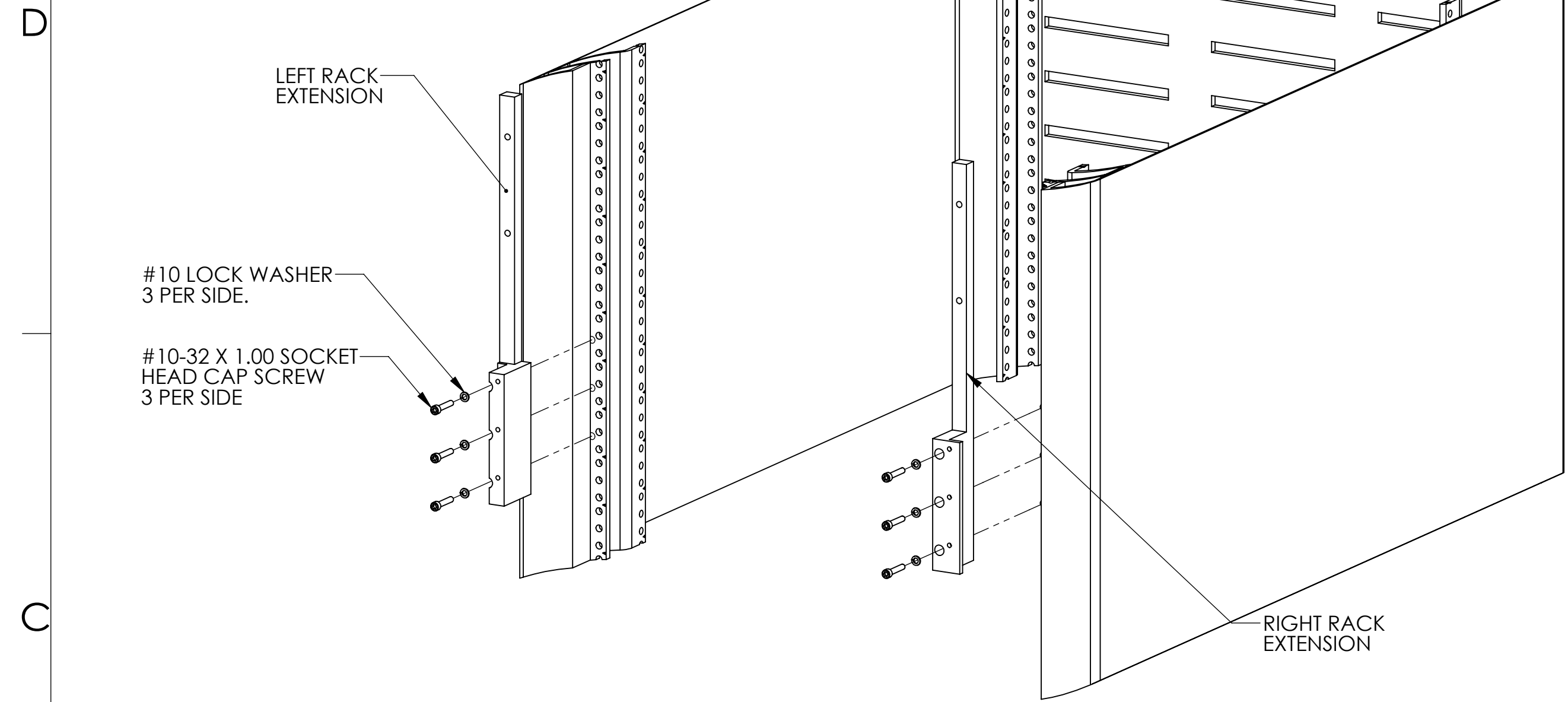

STEP 1: INSTALL LEFT AND RIGHT RACK EXTENSIONS INTO 19" EQUIPMENT RACK USING SIX #10-32 X 1.00 SOCKET HEAD CAP SCREWS AND #10 LOCK WASHERS FROM 310113650.

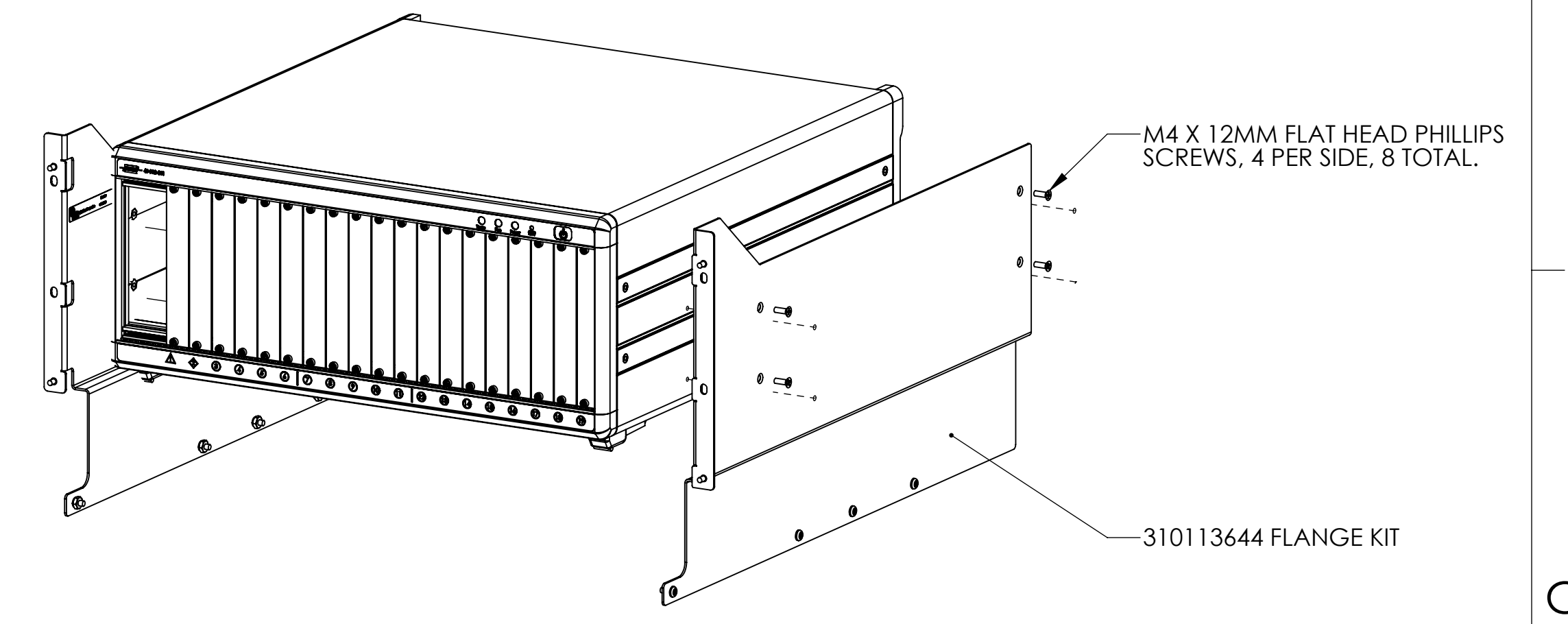

STEP 2: INSTALL 310113644 FLANGES ONTO 90-423-001 CHASSIS (CUSTOMER SUPPLIED) USING EIGHT M4 X 12MM FLAT HEAD PHILLIPS SCREWS (SUPPLIED WITH 310113644). REMOVE CARRY HANDLE AND ALL FEET FROM CHASSIS PRIOR TO ATTACHING FLANGES.

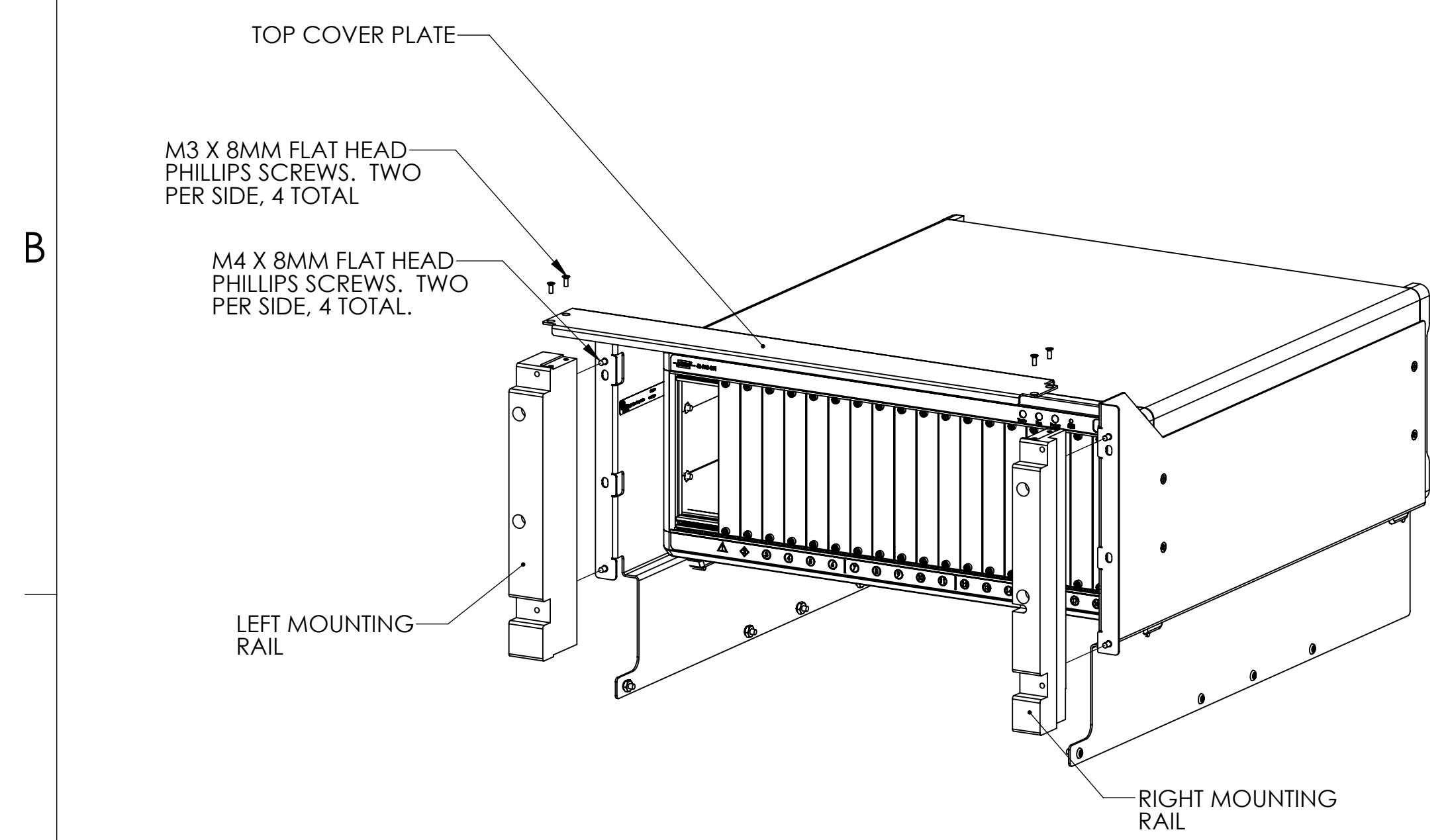

STEP 3: ATTACH LEFT AND RIGHT MOUNTING RAILS TO FLANGES USING FOUR M4X8MM FLAT HEAD PHILLIPS SCREWS INCLUDED WITH 310113644. ATTACH THE TOP COVER PLATE TO THE LEFT AND RIGHT MOUNTING RAILS USING TWO M3 X 8MM FLAT HEAD PHILLIPS SCREWS PER SIDE (4 TOTAL).

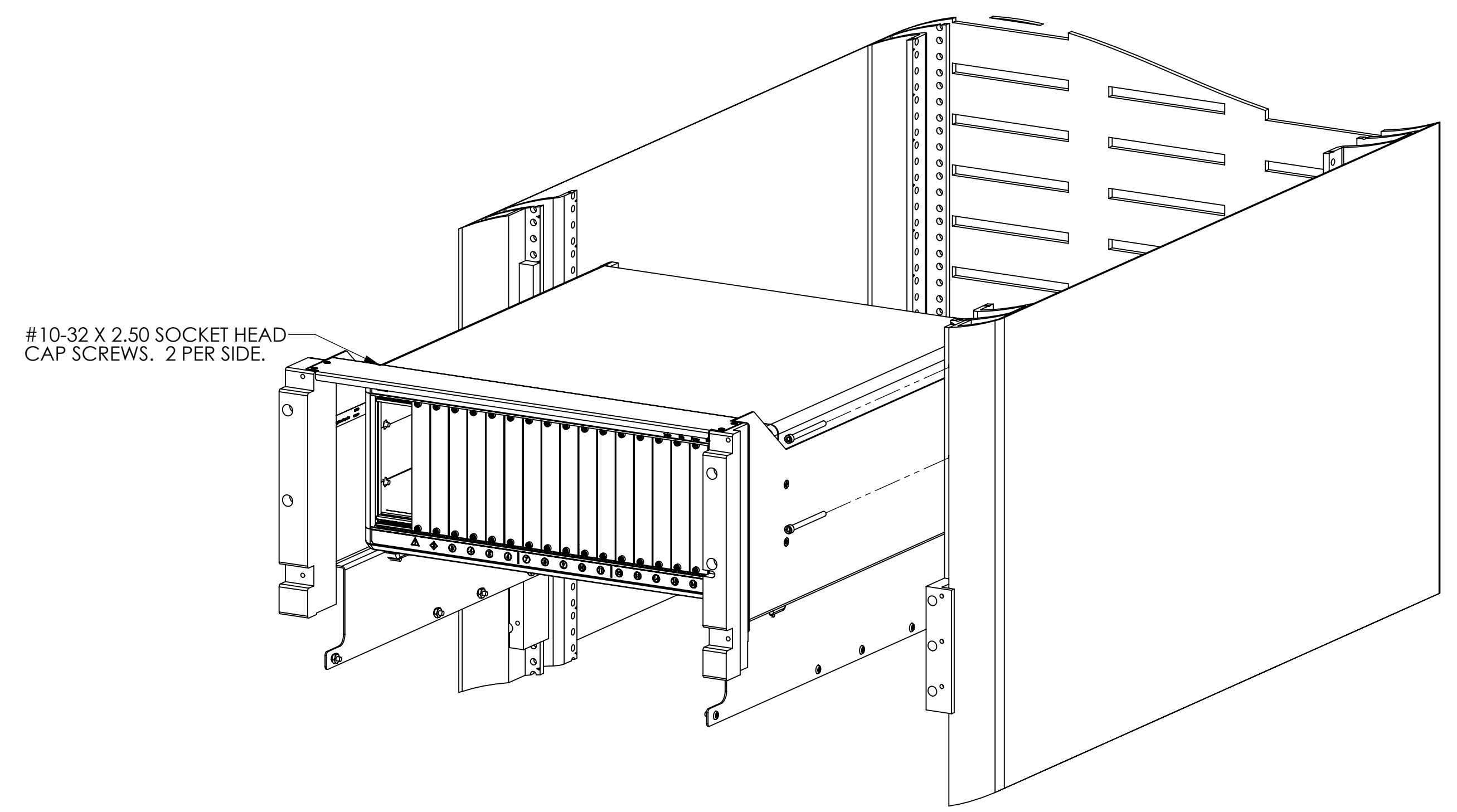

STEP 4: INSTALL SUB-ASSEMBLY FROM STEP #3 INTO 19" EQUIPMENT RACK FROM STEP #1. USE #10-32 X 2.50 SOCKET HEAD CAP SCREWS FROM 310113650 TO SECURE INTO RACK. REAR OF CHASSIS MUST BE SUPPORTED BY CUSTOMER.

NOTES:

CUSTOMER DRAWING				
DIMENSIONS ARE SHOWN AS:	SIZE	CAGE CODE	DWG. NO.	REV
[MILLIMETERS]	D	18117	310120195	A
INCHES	SCALE: 1:4	310120195	3/30/15	SHEET 2 OF 3

DO NOT SCALE DRAWING

D

D

C

C

B

B

A

A

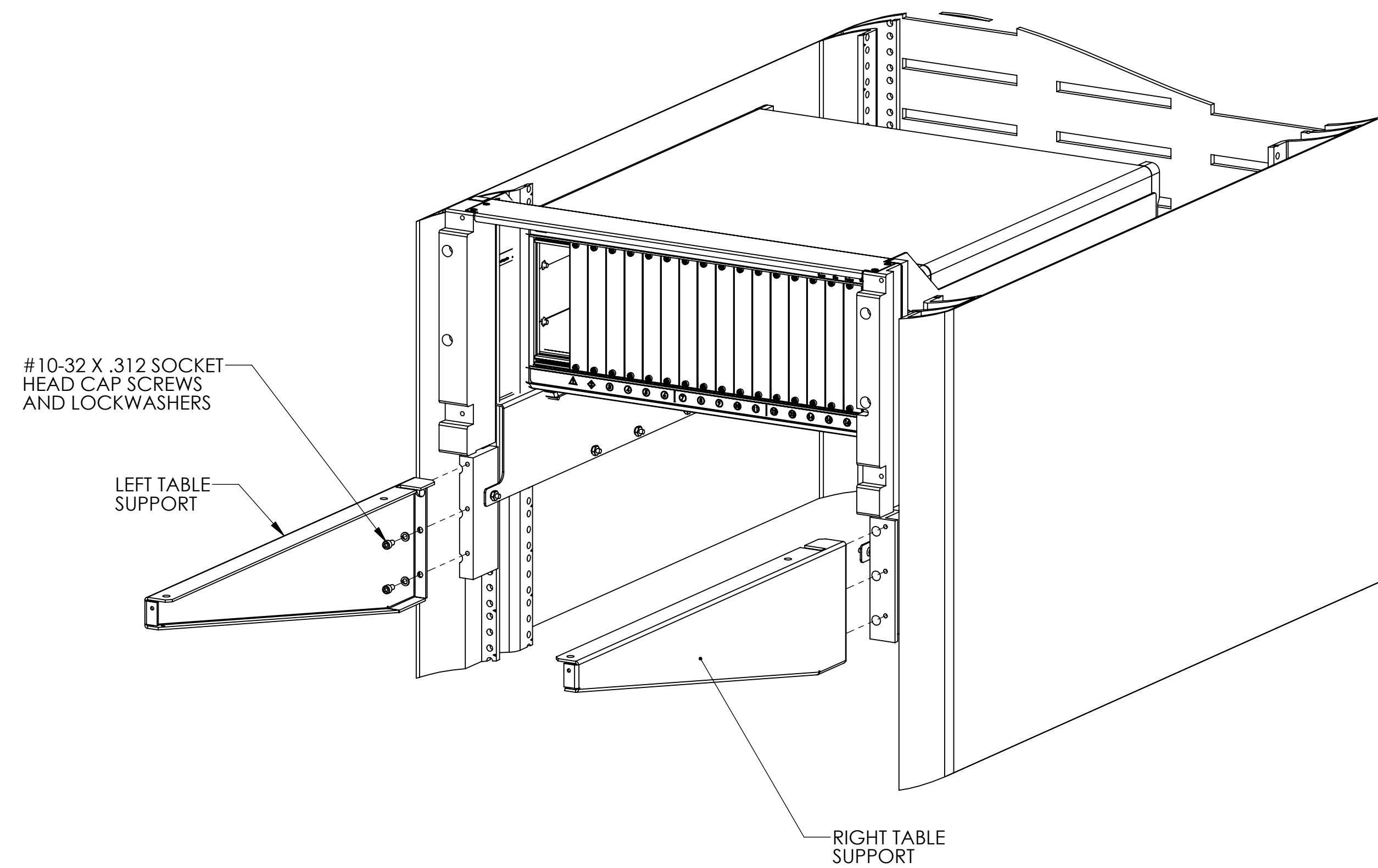

#10-32 X .312 SOCKET HEAD CAP SCREWS AND LOCK WASHERS

LEFT TABLE SUPPORT

RIGHT TABLE SUPPORT

STEP 5: INSTALL LEFT AND RIGHT TABLE SUPPORTS TO LEFT AND RIGHT RACK EXTENSIONS USING THREE #10-32 X .31 SOCKET HEAD CAP SCREWS PER SIDE (6 TOTAL).

NOTES:

M5 X 16MM SOCKET HEAD CAP SCREWS AND FLAT WASHERS, 2 PER SIDE, 4 TOTAL.

#6-32 X .25 100 DEG FLAT HEAD PHILLIPS SCREWS 2 PER SIDE, 4 TOTAL

1/4-20 X .50 SOCKET HEAD CAP SCREWS AND LOCK WASHERS, 4 TOTAL.

FRONT PLATE

STEP 6: MOUNT RECEIVER TO LEFT AND RIGHT TABLE SUPPORTS USING TWO 1/4-20 X .50 SOCKET HEAD CAP SCREWS AND LOCK WASHERS PER SIDE, 4 TOTAL. THEN ATTACH TO LEFT AND RIGHT MOUNTING RAILS USING TWO M5 X 16MM SOCKET HEAD CAP SCREWS AND FLAT WASHERS PER SIDE, 4 TOTAL. ATTACH FRONT PLATE USING TWO #6-32 X .25 100 DEG. FLAT HEAD PHILLIPS SCREWS, TWO PER SIDE, FOUR TOTAL. REFER TO PXI PULL THRU USERS MANUAL AT WWW.VPC.COM FOR FINAL ALIGNMENT PROCEDURES.

CUSTOMER DRAWING

DIMENSIONS ARE SHOWN AS:	SIZE	CAGE CODE	DWG. NO.	REV
[MILLIMETERS]	D	18117	310120195	A
INCHES	SCALE: 1:4	310120195	3/30/15	SHEET 3 OF 3