

## Ceramic Disc Capacitors Class 1, 100 V (DC) Narrow Tolerance

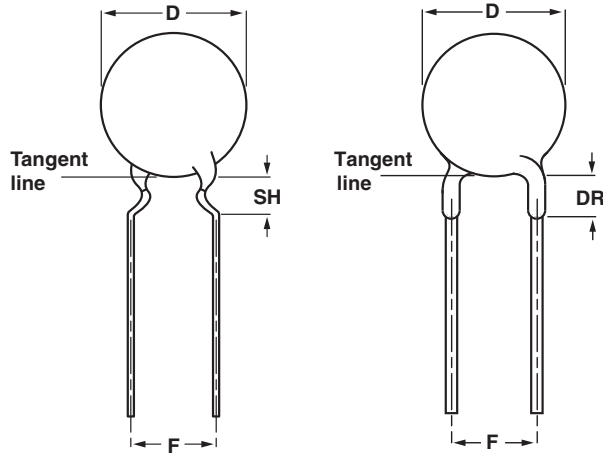

Capacitors with 5 mm (0.20") and 2.5 mm (0.100") lead spacing

### TEMPERATURE COEFFICIENTS:

Class 1 NP0; N750

### SECTIONAL SPECIFICATIONS:

Class 1 IEC 60 384-8,  
EIA 198

### CLIMATIC CATEGORY:

Class 1 55/125/56

### OPERATING TEMPERATURE RANGE:

Class 1 - 55 to + 125 °C

### MARKING

Marking indicates capacitance value and tolerance in accordance with "EIA 198".

### FEATURES

- Low losses
- High stability
- High capacitance in small size
- Kinked (preferred) or straight leads
- Lead (Pb)-free available



**RoHS**  
COMPLIANT

### APPLICATIONS

- Bypassing
- Coupling
- Resonant circuit

### DESIGN

The capacitors consist of a ceramic disc both sides of which are silver-plated. Connection leads are made of tinned copper having a diameter of 0.6 mm.

The capacitors have inward kinked leads with a spacing of 5 mm (0.200") and 2.5 mm (0.100") and a lead length from 4 to 30 mm. Encapsulation is made of phenolic resin.

### CAPACITANCE RANGE:

Class 1, at 1 MHz, 1.2 V (RMS); 1.5 to 560 pF  
1 kHz,  $1 \pm 0.2$  V (RMS) for capacitance values higher than 1000 pF

### RATED DC VOLTAGE:

100 V

### DIELECTRIC STRENGTH:

250 % of rated voltage

### INSULATION RESISTANCE AT 100 V (DC):

$\geq 10\ 000\ M\Omega$

### TOLERANCE ON CAPACITANCE:

$\pm 0.25\ pF$ ;  $\pm 0.5\ pF$ ;  $\pm 2\ %$

### DISSIPATION FACTOR:

Class 1,  $C \leq 30\ pF$ ;  $\leq 20 \times (10/C + 0.7) \times 10^{-4}$  maximum  
Class 1,  $C > 30\ pF$ ;  $\leq 0.2\ %$

The capacitors meet the essential requirements of "EIA 198". Unless stated otherwise all electrical values apply at an ambient temperature of  $25 \pm 3\ ^\circ C$ , at normal atmospheric conditions.

# LV 100 V Narrow Tolerance



Vishay BCcomponents

Ceramic Disc Capacitors  
Class 1, 100 V (DC) Narrow Tolerance

TEMPERATURE COEFFICIENT IN ACCORDANCE WITH "RS198"		
C = 0.0	0 = - 1	G = ± 30
M = 1.0	1 = - 10	H = ± 60
P = 1.5	2 = - 100	J = ± 120
R = 2.2	3 = - 1000	K = ± 250
S = 3.3	5 = + 1	L = ± 500
T = 4.7	6 = + 10	M = ± 1000
U = 7.5	7 = + 100	N = ± 2500
-	8 = + 1000	-

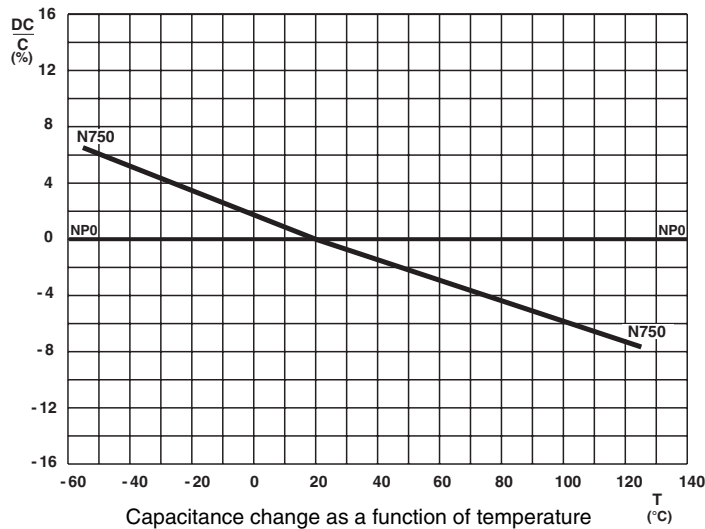

ORDERING INFORMATION, CLASS 1, 100 V (DC), KINKED AND STRAIGHT					
C (pF)	TOL. (%)	D <sub>max</sub> (mm)	LEAD SPACING F (mm)	SH/DR max <sup>(2)</sup> (mm)	CLEAR TEXT CODE
					13 <sup>th</sup> DIGIT: T = REEL; U = AMMO; 3 = BULK
<b>CLASS 1NP0</b>					
1.5	± 0.25 pF	5.0	5.0	4.0	D159C20C0KH6.J5R
1.8			2.5	1.5	D159C20C0KH6.L2R
			5.0	4.0	D189C20C0KH6.J5R
2.2			2.5	1.5	D189C20C0KH6.L2R
			5.0	4.0	D229C20C0JH6.J5R
3.3			2.5	1.5	D229C20C0JH6.L2R
			5.0	4.0	D339C20C0JH6.J5R
4.7			2.5	1.5	D339C20C0JH6.L2R
			5.0	4.0	D479C20C0HH6.J5R
6.8			2.5	1.5	D479C20C0HH6.L2R
			5.0	4.0	D689C20C0HH6.J5R
10			2.5	1.5	D689C20C0HH6.L2R
	5.0	4.0	D100G20C0GH6.J5R		
15	2.5	1.5	D100G20C0GH6.L2R		
	5.0	4.0	D150G20C0GH6.J5R		
22	2.5	1.5	D150G20C0GH6.L2R		
	5.0	4.0	D220G20C0GH6.J5R		
33	2.5	1.5	D220G20C0GH6.L2R		
	5.0	4.0	D330G20C0GH6.J5R		
			2.5	1.5	D330G20C0GH6.L2R



# LV 100 V Narrow Tolerance

Ceramic Disc Capacitors  
Class 1, 100 V (DC) Narrow Tolerance

Vishay BCcomponents

## ORDERING INFORMATION, CLASS 1, 100 V (DC), KINKED AND STRAIGHT

C (pF)	TOL. (%)	D <sub>max</sub> (mm)	LEAD SPACING F (mm)	SH/DR max <sup>(2)</sup> (mm)	CLEAR TEXT CODE	
					13 <sup>th</sup> DIGIT: T = REEL; U = AMMO; 3 = BULK	
47	± 2 %	6.5	5.0	4.0	D470G25C0GH6.J5R	
			2.5	1.5	D470G25C0GH6.L2R	
68			5.0	4.0	D680G25C0GH6.J5R	
			2.5	1.5	D680G25C0GH6.L2R	
100		7.5	5.0	4.0	D101G29C0GH6.J5R	
			2.5	1.5	D101G29C0GH6.L2R	
150		8.5	5.0	4.0	D151G33C0GH6.J5R	
			2.5	1.5	D151G33C0GH6.L2R	
220		11.0	5.0	4.0	D221G43C0GH6.J5R	
			2.5	1.5	D221G43C0GH6.L2R	
<b>CLASS 1 N750</b>						
6.8		± 0.25 pF	5.5	5.0	4.0	D689C20U2JH6.J5R
10	± 2 %	2.5		1.5	D689C20U2JH6.L2R	
		5.0		4.0	D100G20U2JH6.J5R	
15		2.5		1.5	D100G20U2JH6.L2R	
		5.0		4.0	D150G20U2JH6.J5R	
22		2.5		1.5	D150G20U2JH6.L2R	
		5.0		4.0	D220G20U2JH6.J5R	
33		2.5		1.5	D220G20U2JH6.L2R	
		5.0		4.0	D330G20U2JH6.J5R	
47		2.5		1.5	D330G20U2JH6.L2R	
		5.0		4.0	D470G20U2JH6.J5R	
68		6.5		2.5	1.5	D470G20U2JH6.L2R
				5.0	4.0	D680G25U2JH6.J5R
100		7.5		2.5	1.5	D680G25U2JH6.L2R
				5.0	4.0	D101G29U2JH6.J5R
150		8.5		2.5	1.5	D101G29U2JH6.L2R
			5.0	4.0	D151G33U2JH6.J5R	
220	10	2.5	1.5	D151G33U2JH6.L2R		
		5.0	4.0	D221G39U2JH6.J5R		
330	12	2.5	1.5	D221G39U2JH6.L2R		
		5.0	4.0	D331G47U2JH6.J5R		
			2.5	1.5	D331G47U2JH6.L2R	

### Notes

1. Maximum thickness 3.5 mm
2. SH = seated height; DR = run down
3. Lead style codes refer to inward kinked leads and straight leads

## PACKAGING

D <sub>max</sub> (mm)	SIZE CODE	PACKAGING QUANTITIES		
		BULK	REEL	AMMO
5.0 (0.20")	20	1000	2500	2000
6.5 (0.25")	25			
7.5 (0.29")	29			
8.5 (0.33")	33			
10.0 (0.39")	39			
11.0 (0.43")	43			
12.0 (0.47")	47			

### Note

1. The capacitors are supplied in bulk packaging (cardboard boxes), in tape on reel or in ammpack

# LV 100 V Narrow Tolerance

Vishay BCcomponents

Ceramic Disc Capacitors  
Class 1, 100 V (DC) Narrow Tolerance

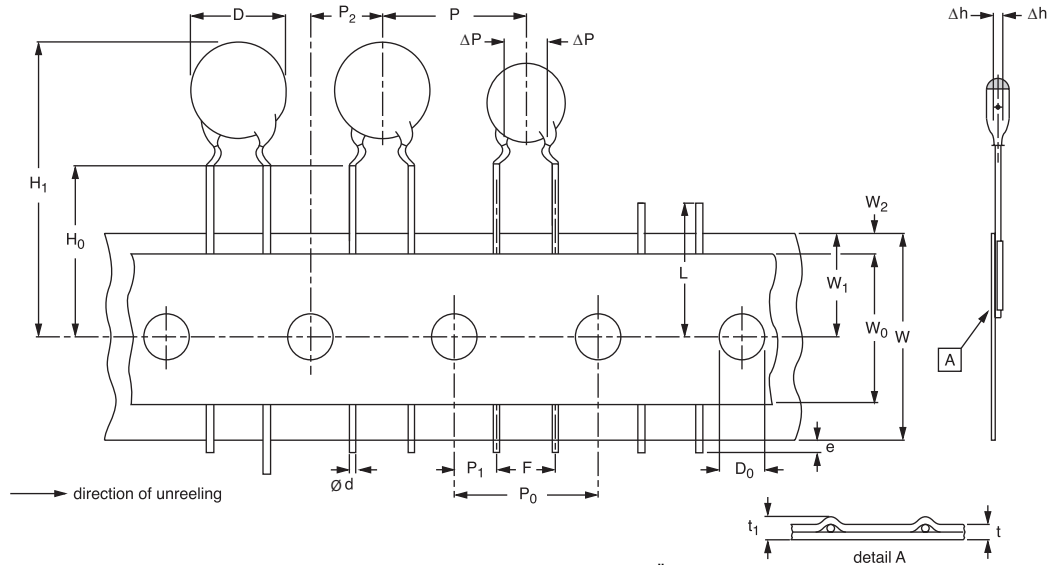

Kinked capacitors on tape, lead spacing 5.0 mm (0.2")

DIMENSIONS OF TAPE		DIMENSIONS (mm)	
		NOMINAL	TOLERANCE
D	body diameter	11.0 maximum	-
d	lead diameter	0.6	± 0.05
P	pitch between capacitors	12.7	± 1.0
P <sub>0</sub>	feed-hole pitch	12.7	± 0.3; note 1
ΔP	plane deviation	1.0 maximum	-
P <sub>1</sub>	feed-hole centre to lead centre	3.85	± 0.7; note 2
P <sub>2</sub>	feed-hole centre to component centre	6.35	± 1.3; note 2
F	lead spacing	5.0	+ 0.6 - 0.4
Δh	component alignment	0	± 1.0
W	tape width	18.0	+ 1.0 - 0.5
W <sub>0</sub>	hold-down tape width	5.0 minimum	-
W <sub>1</sub>	hole position	9.0	+ 0.75 - 0.5
W <sub>2</sub>	hold-down tape margin	3.0 maximum	-
H <sub>0</sub>	height to seating plane	16.0	± 0.5
H <sub>1</sub>	maximum component height	32.0	-
e	lead end protrusion	1.0 maximum	-
L	maximum length of snapped lead	11.0	-
D <sub>0</sub>	feed-hole diameter	4.0	± 0.2
t	total tape thickness	0.9 maximum	-
t <sub>1</sub>	maximum thickness of tape and wires	1.5 maximum	-

## Notes

1. Cumulative pitch error:  $\pm \leq 1$  mm/20 pitches
2. Obliquity maximum 3°



# LV 100 V Narrow Tolerance

Ceramic Disc Capacitors  
Class 1, 100 V (DC) Narrow Tolerance

Vishay BCcomponents

## REEL AND TAPE DATA in millimeters

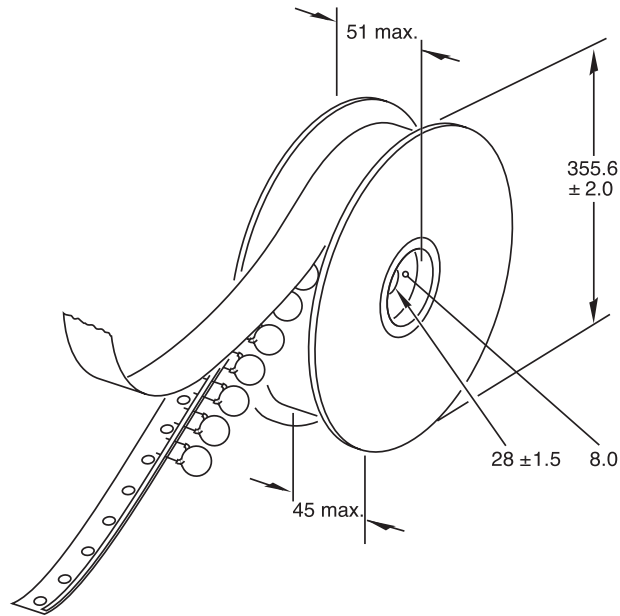

Reel with capacitors on tape

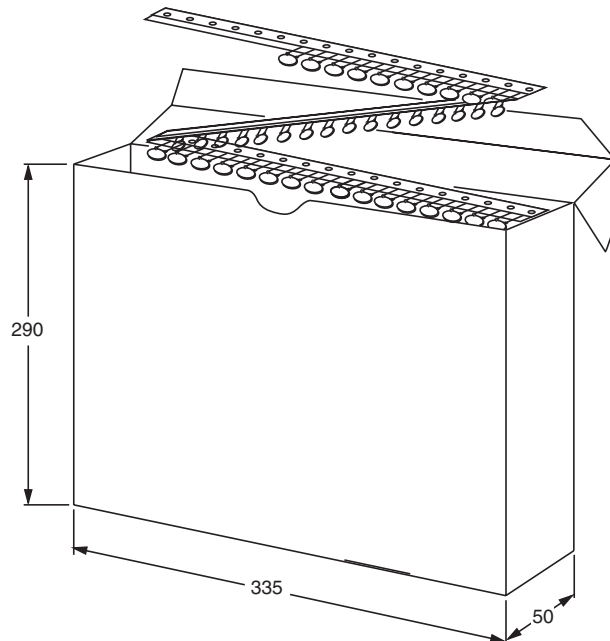

Ampopack with capacitors on tape



## Disclaimer

All product specifications and data are subject to change without notice.

Vishay Intertechnology, Inc., its affiliates, agents, and employees, and all persons acting on its or their behalf (collectively, "Vishay"), disclaim any and all liability for any errors, inaccuracies or incompleteness contained herein or in any other disclosure relating to any product.

Vishay disclaims any and all liability arising out of the use or application of any product described herein or of any information provided herein to the maximum extent permitted by law. The product specifications do not expand or otherwise modify Vishay's terms and conditions of purchase, including but not limited to the warranty expressed therein, which apply to these products.

No license, express or implied, by estoppel or otherwise, to any intellectual property rights is granted by this document or by any conduct of Vishay.

The products shown herein are not designed for use in medical, life-saving, or life-sustaining applications unless otherwise expressly indicated. Customers using or selling Vishay products not expressly indicated for use in such applications do so entirely at their own risk and agree to fully indemnify Vishay for any damages arising or resulting from such use or sale. Please contact authorized Vishay personnel to obtain written terms and conditions regarding products designed for such applications.

Product names and markings noted herein may be trademarks of their respective owners.