



Industrial Memory Specialist & Solution

www.imsolution.com.tw

Industrial Memory Specialist & Solution

MAN Diesel & Turbo SE

SATA 6Gb/s SSD Specification

Revision 2.1



Product Overview of SATA 6Gb/s SSD

- **Capacity**
 - 512GB
- **SATA Interface**
 - SATA Revision 3.1
 - SATA 1.5Gbps, 3Gbps, and 6Gbps interface
- **Flash Interface**
 - Flash type: SLC mode / Psuedo SLC
- **Performance**
 - Read: up to 530 MB/s
 - Write: up to 470 MB/s
- **Power Consumption**
 - Active mode: < 3200mW
 - Idle mode: < 215mW
 - DEVSLP mode: < 5mW
- **TBW (Terabytes Written)**
 - 9100TBW of 512GB model
- **MTBF**
 - > 2M hours
- **Advanced Flash Management**
 - Static and Dynamic Wear Leveling
 - Bad Block Management
 - TRIM
 - NCQ
 - SMART
 - Over-Provision
 - Firmware Update
- **Low Power Management**
 - DEVSLP Mode (Optional)
 - DIPM/HIPM Mode
- **Temperature Range**
 - Operation: 0°C ~ 70°C (c-Temp)
 - Operation: -40°C ~ 85°C (i-Temp)
 - Storage: -40°C ~ 85°C
- **RoHS compliant**



TABLE OF CONTENTS

1.	INTRODUCTION	5
1.0	Part Numbers	5
1.1.	General Description	5
1.2.	Controller Block Diagram	5
1.3.	Product Block Diagram.....	6
1.4.	Flash Management.....	6
1.4.1.	<i>Error Correction Code (ECC)</i>	6
1.4.2.	<i>Wear Leveling</i>	6
1.4.3.	<i>Bad Block Management</i>	7
1.4.4.	<i>TRIM</i>	7
1.4.5.	<i>SMART</i>	7
1.4.6.	<i>Over-Provision</i>	7
1.4.7.	<i>Firmware Upgrade</i>	8
1.5.	Low Power Management	8
1.5.1.	<i>DIPM/HIPM Mode</i>	8
1.6.	Power Loss Protection: Flushing Mechanism	8
1.7.	Advanced Device Security Features	8
1.7.1.	<i>Secure Erase</i>	8
1.7.2.	<i>Write Protect</i>	9
1.8.	SSD Lifetime Management.....	9
1.8.1.	<i>Terabytes Written (TBW)</i>	9
1.9.	An Adaptive Approach to Performance Tuning.....	9
1.9.1.	<i>Throughput</i>	9
1.9.2.	<i>Predict & Fetch</i>	10
1.10.	Pseudo SLC	10
2.	PRODUCT SPECIFICATIONS	11
3.	ENVIRONMENTAL SPECIFICATIONS.....	12
3.1.	Environmental Conditions.....	12
3.1.1.	<i>Temperature and Humidity</i>	12
3.1.2.	<i>Shock</i>	13
3.1.3.	<i>Vibration</i>	13
3.1.4.	<i>Drop</i>	13
3.1.5.	<i>Bending</i>	13



3.1.6.	Torque	14
3.1.7.	Electrostatic Discharge (ESD)	14
3.1.8.	EMI Compliance	14
3.2.	MTBF	14
3.3.	Certification & Compliance	14
4.	ELECTRICAL SPECIFICATIONS.....	15
4.1.	Supply Voltage.....	15
4.2.	Power Consumption.....	15
5.	INTERFACE.....	16
5.1.	Pin Assignment and Descriptions.....	16
6.	SUPPORTED COMMANDS.....	17
6.1.	ATA Command List.....	17
6.2.	Identify Device Data	18
7.	PHYSICAL DIMENSION	22
8.	TERMINOLOGY	23

1. INTRODUCTION



1.0 Part Numbers

P/N (C TEMP)	CAPACITY	SEQUENTIAL	
		Read(MB/s)	Write(MB/s)
FA512GS3T-MAN2	512GB SSD	530	470

1.1. General Description

Imsolution's 2.5" SATA Solid State Disk (SSD) delivers cutting edge flash drive technology with Serial ATA III interface, including being fully compliant with standard 2.5-inch form factor, providing low power consumption compared to traditional hard drive and hot-swapping when removing/replacing/upgrading flash disks. The device is designed based on the standard 7-pin interface for data segment and 15-pin for power segment. Its capacity could provide a wide range up to 512GB. Read/Write performance up to 530/470 MB/s. The drive PCB has been conformal coated using an epoxy layer.

1.2. Controller Block Diagram

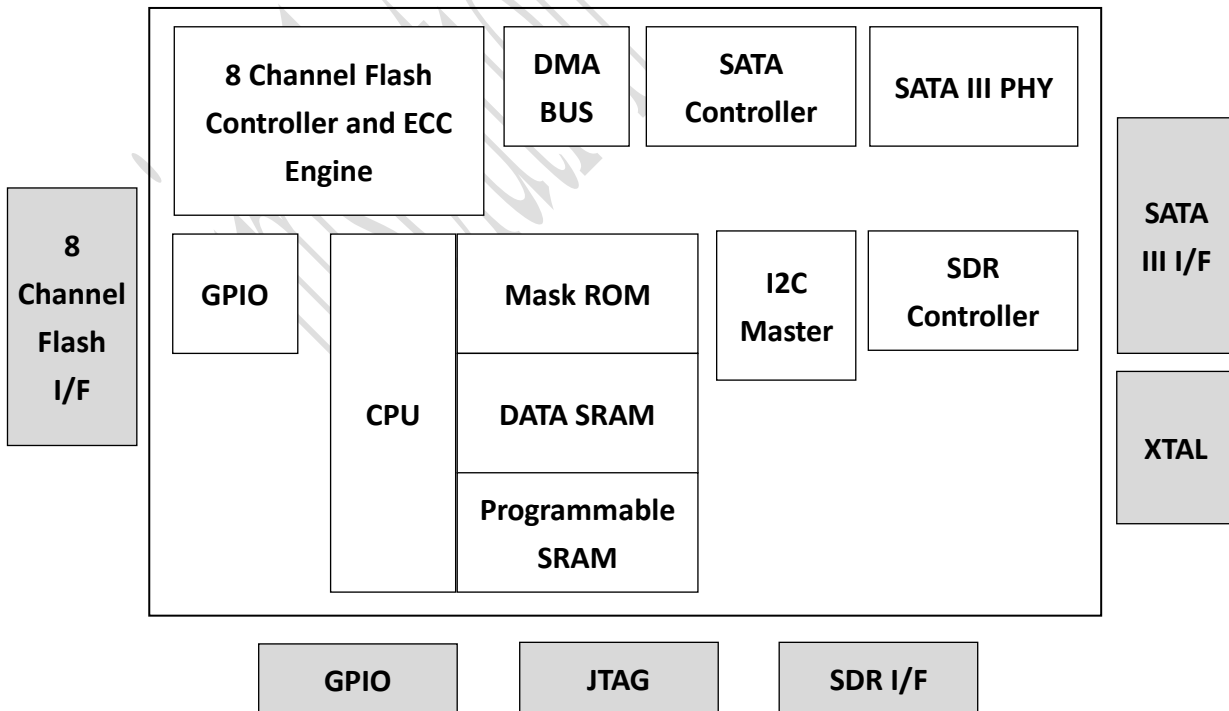

Figure 1-1 Controller Block Diagram

1.3. Product Block Diagram

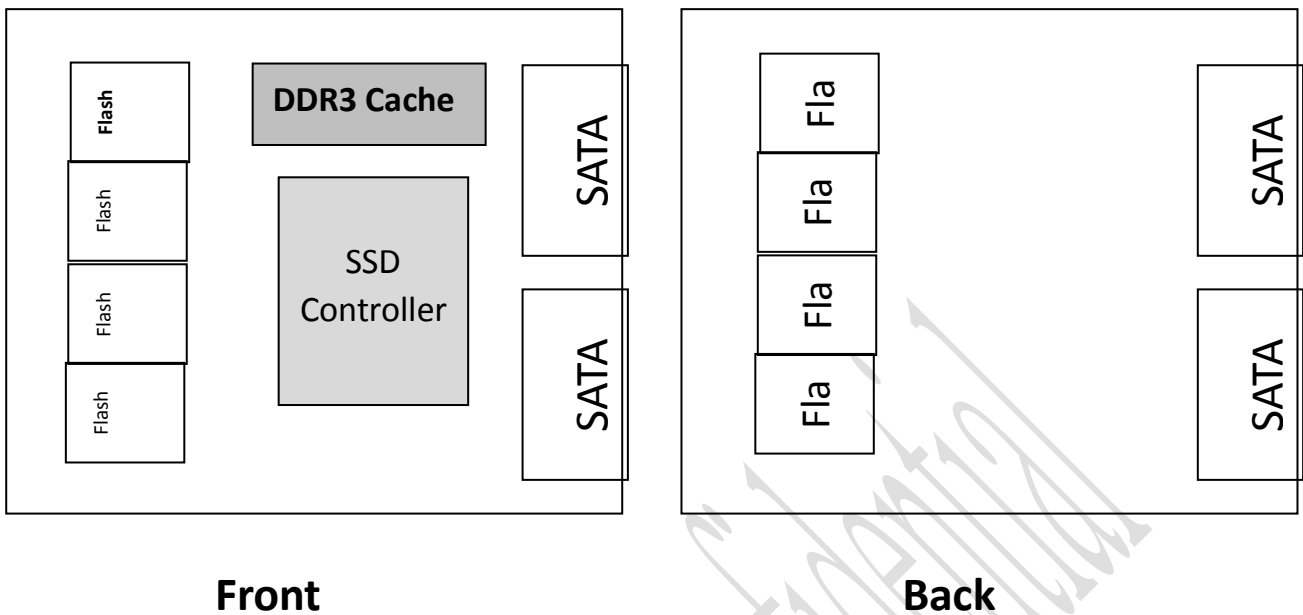

Figure 1-2 Product Block Diagram

1.4. Flash Management

1.4.1. Error Correction Code (ECC)

Flash memory cells will deteriorate with use, which might generate random bit errors in the stored data. Thus, IMSOLUTION SSD 2.5" SATA SSD applies the BCH ECC algorithm, which can detect and correct errors occur during read process, ensure data been read correctly, as well as protect data from corruption.

1.4.2. Wear Leveling

NAND flash devices can only undergo a limited number of program/erase cycles, and in most cases, the flash media are not used evenly. If some areas get updated more frequently than others, the lifetime of the device would be reduced significantly. Thus, Wear Leveling is applied to extend the lifespan of NAND flash by evenly distributing write and erase cycles across the media.

Imsolution provides advanced Wear Leveling algorithm, which can efficiently spread out the flash usage through the whole flash media area. Moreover, by implementing both dynamic and static Wear Leveling algorithms, the life expectancy of the NAND flash is greatly improved.

1.4.3. Bad Block Management

Bad blocks are blocks that include one or more invalid bits, and their reliability is not guaranteed. Blocks that are identified and marked as bad by the manufacturer are referred to as “Initial Bad Blocks”. Bad blocks that are developed during the lifespan of the flash are named “Later Bad Blocks”. Imsolution implements an efficient bad block management algorithm to detect the factory-produced bad blocks and manages any bad blocks that appear with use. This practice further prevents data being stored into bad blocks and improves the data reliability.

1.4.4. TRIM

TRIM is a feature which helps improve the read/write performance and speed of solid-state drives (SSD). Unlike hard disk drives (HDD), SSDs are not able to overwrite existing data, so the available space gradually becomes smaller with each use. With the TRIM command, the operating system can inform the SSD which blocks of data are no longer in use and can be removed permanently. Thus, the SSD will perform the erase action, which prevents unused data from occupying blocks all the time.

1.4.5. SMART

SMART, an acronym for Self-Monitoring, Analysis and Reporting Technology, is an open standard that allows a hard disk drive to automatically detect its health and report potential failures. When a failure is recorded by SMART, users can choose to replace the drive to prevent unexpected outage or data loss. Moreover, SMART can inform users of impending failures while there is still time to perform proactive actions, such as copy data to another device.

1.4.6. Over-Provision

Over Provisioning refers to the inclusion of extra NAND capacity in a SSD, which is not visible and cannot be used by users. With Over Provisioning, the performance and IOPS (Input / Output Operations per Second) are improved by providing the controller additional space to manage P/E cycles, which enhances the reliability and endurance as well. Moreover, the write amplification of the SSD becomes lower when the controller writes data to the flash.

1.4.7. Firmware Upgrade

Firmware can be considered as a set of instructions on how the device communicates with the host. Firmware will be upgraded when new features are added, compatibility issues are fixed, or read/write performance gets improved.

1.5. Low Power Management

1.5.1. DIPM/HIPM Mode

SATA interfaces contain two low power management states for power saving: Partial and Slumber modes. For Partial mode, the device has to resume to full operation within 10 microseconds, whereas the device will spend 10 milliseconds to become fully operational in the Slumber mode. SATA interfaces allow low power modes to be initiated by Host (HIPM, Host Initiated Power Management) or Device (DIPM, Device Initiated Power Management). As for HIPM, Partial or Slumber mode can be invoked directly by the software. For DIPM, the device will send requests to enter Partial or Slumber mode.

1.6. Power Loss Protection: Flushing Mechanism

Power Loss Protection is a mechanism to prevent data loss during unexpected power failure. DRAM is a volatile memory and frequently used as temporary cache or buffer between the controller and the NAND flash to improve the SSD performance. However, one major concern of the DRAM is that it is not able to keep data during power failure. For IMSOLUTION SSD, SDR performs as a cache, and its sizes include 8MB or 32MB. Only when the data is fully committed to the NAND flash will the controller send acknowledgement (ACK) to the host. Such implementation can prevent false-positive performance and the risk of power cycling issues. In general, IMSOLUTION SSD proves to provide the reliability required by consumer, industrial, and enterprise-level applications.

1.7. Advanced Device Security Features

1.7.1. Secure Erase

Secure Erase is a standard ATA command and will write all "0xFF" to fully wipe all the data on hard drives and SSDs. When this command is issued, the SSD controller will erase its storage blocks and return to its factory default settings.

1.7.2. Write Protect

When a SSD contains too many bad blocks and data are continuously written in, then the SSD might not be usable anymore. Thus, Write Protect is a mechanism to prevent data from being written in and protect the accuracy of data that are already stored in the SSD.

1.8. SSD Lifetime Management

1.8.1. Terabytes Written (TBW)

TBW (Terabytes Written) is a measurement of SSDs' expected lifespan, which represents the amount of data written to the device. To calculate the TBW of a SSD, the following equation is applied:

$$TBW = [(NAND\ Endurance) \times (SSD\ Capacity) \times (WLE)] / WAF$$

NAND Endurance: NAND endurance refers to the P/E (Program/Erase) cycle of a NAND flash.

SSD Capacity: The SSD capacity is the specific capacity in total of a SSD.

WLE: Wear Leveling Efficiency (WLE) represents the ratio of the average amount of erases on all the blocks to the erases on any block at maximum.

WAF: Write Amplification Factor (WAF) is a numerical value representing the ratio between the amount of data that a SSD controller needs to write and the amount of data that the host's flash controller writes. A better WAF, which is near 1, guarantees better endurance and lower frequency of data written to flash memory.

1.9. An Adaptive Approach to Performance Tuning

1.9.1. Throughput

Based on the available space of the disk, IMSOLUTION SSD will regulate the read/write speed and manage the performance of throughput. When there still remains a lot of space, the firmware will continuously perform read/write action. There is still no need to implement garbage collection to allocate and release memory, which will accelerate the read/write processing to improve the performance. Contrarily, when the space is going to be used up, IMSOLUTION SSD will slow down the read/write processing, and implement garbage collection to release memory. Hence, read/write performance will become slower.

1.9.2. Predict & Fetch

Normally, when the host tries to read data from the SSD, the SSD will only perform one read action after receiving one command. However, IMSOLUTION SSD applies **Predict & Fetch** to improve the read speed. When the host issues sequential read commands to the SSD, the SSD will automatically expect that the following will also be read commands. Thus, before receiving the next command, next page/sector data of flash has been already prepared to be read out. Accordingly, this accelerates the data processing time, and the host does not need to wait so long to receive data.

1.10. Pseudo SLC

Pseudo SLC can be considered as an extended version of the MLC. While MLC contains both fast and slow pages, pseudo SLC only applies fast pages for programming. The concept of pseudo SLC is demonstrated in the two tables below. The first and second bits of a memory cell represent a fast and slow page respectively, as shown in the left table. Since only fast pages are programmed when applying pseudo SLC, the bits highlighted in red are used, as shown in the right table. Accordingly, because only fast pages are programmed, pseudo SLC provides better performance and endurance than MLC. Moreover, pseudo SLC performs similarly to the SLC, yet more cost effective. One thing to note regarding pseudo SLC is that due to the mechanism of only programming fast pages, the capacity of the device will be halved in order to achieve higher performance.

MLC Flash		→	Pseudo SLC	
1 st bit (fast)	2 nd bit (slow)		1 st bit (fast)	2 nd bit (slow)
1	1		1	1
1	0		1	0
0	1		0	1
0	0		0	0



2. PRODUCT SPECIFICATIONS



- **Capacity**
 - From 32GB up to 1TB
- **Electrical/Physical Interface**
 - SATA Interface
 - ◆ Compliant with SATA Revision 3.1
 - ◆ Compatible with SATA 1.5Gbps, 3Gbps and 6Gbps interface
 - ◆ NCQ support up to queue depth = 32
 - ◆ Support power management
 - ◆ Support expanded register for SATA protocol 48 bits addressing mode
 - ◆ Embedded BIST function for SATA PHY for low cost mass production
- **Supported NAND Flash**
 - Toshiba 19nm / A19nm MLC, Toggle1.0 and Toggle2.
 - Supports MLC large block 16K/page NAND flash
 - Support ONFI 3.0 and Toggle 2.0 interface: 5 channels at maximum
- **ECC Scheme**
 - IMSOLUTION SSD 2.5" SATA SSD can correct up to 72 bits error in 1K Byte data.
- **UART function**
- **GPIO**
- **Support SMART and TRIM commands**



3. ENVIRONMENTAL SPECIFICATIONS



3.1. Environmental Conditions

3.1.1. Temperature and Humidity

- Temperature:
 - ◆ Storage: -40°C to 85°C
 - ◆ Operational: 0°C to 70°C (C-temp)
 - ◆ Operational: -40°C to 85°C (i-Temp)
- Humidity:
 - ◆ RH 90% under 40°C (operational)

Table 3-1 High Temperature Test Condition

	Temperature	Humidity	Test Time
Operation (C-Temp)	70°C	0% RH	72 hours
Operation (I-Temp)	85°C	0% RH	72 hours
Storage (C-Temp)	85°C	0% RH	72 hours
Storage (I-Temp)	85°C	0% RH	168 hours

Result: No any abnormality is detected.

Table 3-2 Low Temperature Test Condition

	Temperature	Humidity	Test Time
Operation (C-Temp)	0°C	0% RH	72 hours
Operation (I-Temp)	-40°C	0% RH	72 hours
Storage (C-Temp)	-40°C	0% RH	72 hours
Storage (I-Temp)	-40°C	0% RH	168 hours

Result: No any abnormality is detected.

Table 3-3 High Humidity Test Condition

	Temperature	Humidity	Test Time
Operation (C-Temp)	0°C	0% RH	72 hours
Operation (I-Temp)	-40°C	0% RH	72 hours
Storage (C-Temp)	-40°C	0% RH	72 hours
Storage (I-Temp)	-40°C	0% RH	168 hours

Result: No any abnormality is detected.

**Table 3-4 Temperature Cycle Test**

	Temperature	Test time	Cycle
Operation (C-Temp)	0°C	30 min	10 cycles
	70°C	30 min	
Operation (I-Temp)	-40°C	30 min	20 cycles
	85°C	30 min	
Storage (C-Temp)	-40°C	30 min	10 cycles
	85°C	30 min	
Storage (I-Temp)	-40°C	30 min	50 cycles
	85°C	30 min	

Result: No any abnormality is detected.

3.1.2. Shock

Table 3-5 Shock Specification

	Acceleration Force	Half Sin Pulse Duration
Non-operational	1500G	0.5ms
Operational	1500G	0.5ms

Result: No any abnormality is detected when power on.

3.1.3. Vibration

Table 3-6 Vibration Specification

	Condition		Vibration Orientation
	Frequency/Displacement	Frequency/Acceleration	
Operational	20Hz~80Hz/1.52mm	80Hz~2000Hz/20G	X, Y, Z axis/60 min for each

Result: No any abnormality is detected when power on.

3.1.4. Drop

Table 3-7 Drop Specification

	Height of Drop	Number of Drop
Non-operational	80cm free fall	6 face of each unit

Result: No any abnormality is detected when power on.

3.1.5. Bending

Table 3-8 Bending Specification

	Force	Action
Non-operational	≥ 50N	Hold 1min/5times

Result: No any abnormality is detected when power on.

3.1.6. Torque

Table 3-9 Torque Specification

	Force	Action
Non-operational	1.263N-m or 10deg	Hold 1min/5times

Result: No any abnormality is detected when power on.

3.1.7. Electrostatic Discharge (ESD)

Table 3-10 Contact ESD Specification

Device	Temperature	Relative Humidity	+/- 4KV	Result
2.5" SSD	24.0°C	49% (RH)	Device functions are affected, but EUT will be back to its normal or operational state automatically.	PASS

3.1.8. EMI Compliance

- FCC: CISPR22
- CE: EN55022
- BSMI 13438

3.2. MTBF

MTBF, an acronym for Mean Time Between Failures, is a measure of a device's reliability. Its value represents the average time between a repair and the next failure. The measure is typically in units of hours. The higher the MTBF value, the higher the reliability of the device. The predicted result of Imsolution's IMSOLUTION SSD 2.5" SATA SSD is more than 2,000,000 hours.

3.3. Certification & Compliance

- RoHS
- SATA III (SATA Rev. 3.1)
- Up to ATA/ATAPI-8 (Including S.M.A.R.T)



4. ELECTRICAL SPECIFICATIONS



4.1. Supply Voltage

Table 4-1 Supply Voltage

Parameter	Rating
Operating Voltage	3.3V +/-5% (Default) 5V +/- 5% (Option)
Maximum Ripple	100mV, 0~30MHz

4.2. Power Consumption

Table 4-2 Power Consumption

Capacity	Read	Write	Partial	Slumber	Idle
32GB	1,540	1,520	53	40	195
64GB	1,540	2,260	50	35	195
128GB	1,580	2,730	50	35	190
256GB	3,100	3,200	70	55	215

Unit: mW

5. INTERFACE

5.1. Pin Assignment and Descriptions

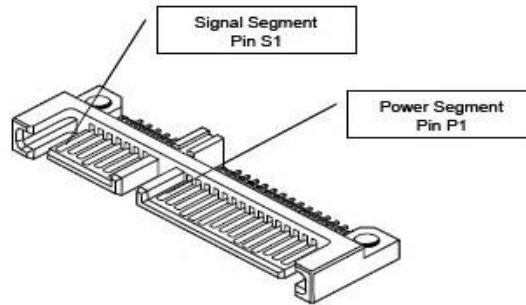

Figure 5-1 IMSOLUTION SSD 2.5" SATA SSD Pin Assignment

Table 5-1 Signal Segment Pin Assignment and Descriptions

Pin Number	Function
S1	GND
S2	A+ (Differential Signal Pair A)
S3	A – (Differential Signal Pair A)
S4	GND
S5	B – (Differential Signal Pair B)
S6	B+ (Differential Signal Pair B)
S7	GND

Table 5-2 Power Segment Pin Assignment and Descriptions

Pin Number	Function
P1	Not Used (3.3V)
P2	Not Used (3.3V)
P3	DEVSLP
P4	GND
P5	GND
P6	GND
P7	5V pre-charge
P8	5V
P9	5V
P10	GND
P11	Reserved
P12	GND
P13	Not Used (12V pre-charge)
P14	Not Used (12V)
P15	Not Used (12V)

6. SUPPORTED COMMANDS

6.1. ATA Command List

Table 6-1 ATA Command List

Op Code	Description	Op Code	Description
00h	NOP	97h	IDLE
06h	Data Set Management	98h	CHECK POWER MODE
10h-1Fh	Recalibrate	99h	SLEEP
20h	Read Sectors	B0h	SMART
21h	Read Sectors without Retry	B1h	DEVICE CONFIGURATION
24h	Read Sectors EXT	C4h	Read Multiple
25h	Read DMA EXT	C5h	Write Multiple
27h	Read Native Max Address EXT	C6h	Set Multiple Mode
29h	Read Multiple EXT	C8h	Read DMA
2Fh	Read Log EXT	C9h	Read DMA without Retry
30h	Write Sectors	CAh	Write DMA
31h	Write Sectors without Retry	CBh	Write DMA without Retry
34h	Write Sectors EXT	CEh	Write Multiple FUA EXT
35h	Write DMA EXT	E0h	Standby Immediate
37h	Set Native Max Address EXT	E1h	Idle Immediate
38h	CFA WRITE SECTORS WITHOUT ERASE	E2h	Standby
39h	Write Multiple EXT	E3h	Idle
3Dh	Write DMA FUA EXT	E4h	Read Buffer
3Fh	Write Long EXT	E5h	Check Power Mode
40h	Read Verify Sectors	E6h	Sleep
41h	Read Verify Sectors without Retry	E7h	Flush Cache
42h	Read Verify Sectors EXT	E8h	Write Buffer
45h	WRITE UNCORRECTABLE EXT	EAh	Flush Cache EXT
60h	Read FPDMA Queued	ECh	Identify Device
61h	Write FPDMA Queued	EFh	Set Features
70h-7Fh	Seek	F1h	Security Set Password
90h	Execute Device Diagnostic	F2h	Security Unlock
91h	Initialize Device Parameters	F3h	Security Erase Prepare
92h	Download Microcode	F4h	Security Erase Unit
93h	DOWNLOAD MICROCODE DMA	F5h	Security Freeze Lock
94h	STANDBY IMMEDIATE	F6h	Security Disable Password
95h	IDLE IMMEDIATE	F8h	Read Native Max Address



96h	STANDBY	F9h	Set Max Address
-----	---------	-----	-----------------

6.2. Identify Device Data

The following table details the sector data returned by the IDENTIFY DEVICE command.

Table 6-2 List of Device Identification

Word	F: Fixed V: Variable X: Both	Default Value	Description
0	F	0040h	General configuration bit-significant information
1	X	*1	Obsolete – Number of logical cylinders
2	V	C837h	Specific configuration
3	X	0010h	Obsolete – Number of logical heads (16)
4-5	X	00000000h	Retired
6	X	003Fh	Obsolete – Number of logical sectors per logical track (63)
7-8	V	00000000h	Reserved for assignment by the Compact Flash Association
9	X	0000h	Retired
10-19	F	Varies	Serial number (20 ASCII characters)
20-21	X	0000h	Retired
22	X	0000h	Obsolete
23-26	F	Varies	Firmware revision (8 ASCII characters)
27-46	F	Varies	Model number (xxxxxxx)
47	F	8010h	7:0- Maximum number of sectors transferred per interrupt on MULTIPLE commands
48	F	4000h	Trusted Computing feature set options(not support)
49	F	2F00h	Capabilities
50	F	4000h	Capabilities
51-52	X	00000000h	Obsolete
53	F	0007h	Words 88 and 70:64 valid
54	X	*1	Obsolete – Number of logical cylinders
55	X	0010h	Obsolete – Number of logical heads (16)
56	X	003Fh	Obsolete – Number of logical sectors per track (63)
57-58	X	*2	Obsolete – Current capacity in sectors
59	F	0110h	Number of sectors transferred per interrupt on MULTIPLE commands
60-61	F	*3	Maximum number of sector (28bit LBA mode)



62	X	0000h	Obsolete
63	F	0407h	Multi-word DMA modes supported/selected
Word	F: Fixed V: Variable X: Both	Default Value	Description
64	F	0003h	PIO modes supported
65	F	0078h	Minimum Multiword DMA transfer cycle time per word
66	F	0078h	Manufacturer's recommended Multiword DMA transfer cycle time
67	F	0078h	Minimum PIO transfer cycle time without flow control
68	F	0078h	Minimum PIO transfer cycle time with IORDY flow control
69	F	0100h	Additional Supported (support download microcode DMA)
70	F	0000h	Reserved
71-74	F	0000000000000000 0h	Reserved for the IDENTIFY PACKET DEVICE command
75	F	001Fh	Queue depth
76	F	670eh	Serial SATA capabilities
77	F	0084h	Serial ATA Additional Capabilities
78	F	014Ch	Serial ATA features supported
79	V	0040h	Serial ATA features enabled
80	F	07F8h	Major Version Number
81	F	0000h	Minor Version Number
82	F	346bh	Command set supported
83	F	7d09h	Command set supported
84	F	6063h	Command set/feature supported extension
85	V	3469h	Command set/feature enabled
86	V	bc01h	Command set/feature enabled
87	V	6063h	Command set/feature default
88	V	003Fh	Ultra DMA Modes
89	F	0001h	Time required for security erase unit completion
90	F	001Eh	Time required for Enhanced security erase completion
91	V	0000h	Current advanced power management value
92	V	FFFEh	Master Password Revision Code
93	F	0000h	Hardware reset result. The contents of the bits (12:0) of this word can be changed only during the execution



			of hardware reset.
94	V	0000h	Vendor's recommended and actual acoustic management value
Word	F: Fixed V: Variable X: Both	Default Value	Description
95	F	0000h	Stream Minimum Request Size
96	V	0000h	Streaming Transfer Time – DMA
97	V	0000h	Streaming Access Latency – DMA and PIO
98-99	F	0000h	Streaming Performance Granularity
100-103	V	*4	Maximum user LBA for 48 bit Address feature set
104	V	0000h	Streaming Transfer Time – PIO
105	F	0008h	Maximum number of 512-byte blocks per DATA SET MANAGEMENT command
106	F	4000h	Physical sector size/Logical sector size
107	F	0000h	Inter-seek delay for ISO-7779 acoustic testing in microseconds
108-111	F	0000000000000000 0h	Unique ID
112-115	F	0000000000000000 0h	Reserved
116	V	0000h	Reserved
117-118	F	00000000h	Words per logical Sector
119	F	4014h	Supported settings
120	F	4014h	Command set/Feature Enabled/Supported
121-126	F	0h	Reserved
127	F	0h	Removable Media Status Notification feature set support
128	V	0021h	Security status
129-140	X	0h	Vendor specific
141	X	0001h	Vendor specific
142-159	X	0h	Vendor specific
160	F	0h	Compact Flash Association (CFA) power mode 1
161-167	X	0h	Reserved for assignment by the CFA
168	F	3h 2.5 inch 4h 1.8 inch 5h Less than 1.8 inch	Device Nominal Form Factor



169	F	0001h	DATA SET MANAGEMENT command is supported
170-173	F	0h	Additional Product Identifier
174-175		0h	Reserve
176-205	V	0h	Current media serial number
Word	F: Fixed V: Variable X: Both	Default Value	Description
206	F	0h	SCT Command Transport
207-208	F	0h	Reserved
209	F	4000h	Alignment of logical blocks within a physical block
210-211	V	0000h	Write-Read-Verify Sector Count Mode 3 (not support)
212-213	F	0000h	Write-Read-Verify Sector Count Mode 2 (not support)
214-216		0000h	NV Cache relate (not support)
217	F	0001h	Non-rotating media device
218	F	0h	Reserved
219	F	0h	NV Cache relate (not support)
220	V	0h	Write read verify feature set current mode
221		0h	Reserved
222	F	107Fh	Transport major version number
223	F	0h	Transport minor version number
224-229		0h	reserved
230-233		0h	Extend number of user addressable sectors
234		0001h	Minimum number of 512-byte data blocks per DOWNLOAD MICROCODE command for mode 03h
235		0080h	Maximum number of 512-byte data blocks per DOWNLOAD MICROCODE command for mode 03h
236-254	F	0h	Reserved
255	X	XXA5h XX is variable	Integrity word (Checksum and Signature)



7. PHYSICAL DIMENSION

Dimension: 100.00mm(L) x 69.85mm(W) x 7.00mm(H)

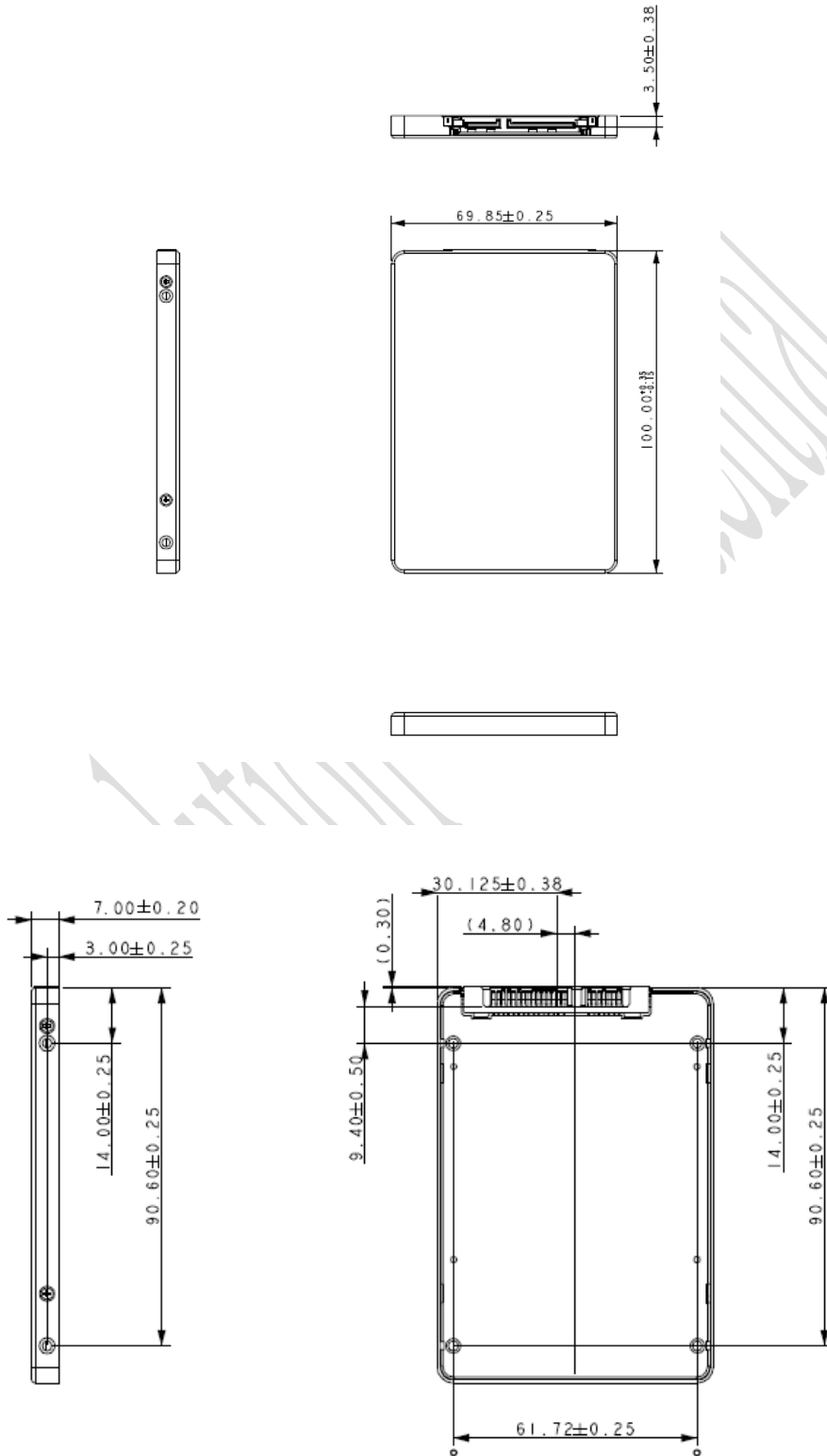

8. TERMINOLOGY



The following table is to list out the acronyms that have been applied throughout the document.

Table 8-1 List of Terminology

Term	Definitions
ATTO	Commercial performance benchmark application
DEVSLP	Device sleep mode
DIPM	Device initiated power management
HIPM	Host initiated power management
LBA	Logical block addressing
MB	Mega-byte
MTBF	Mean time between failures
NCQ	Native command queue
SATA	Serial advanced technology attachment
SDR	Synchronous dynamic access memory
S.M.A.R.T.	Self-monitoring, analysis and reporting technology
SSD	Solid state disk