

# Ceramic Resonators (CERALOCK®)

## CERAMIC RESONATORS (CERALOCK®)

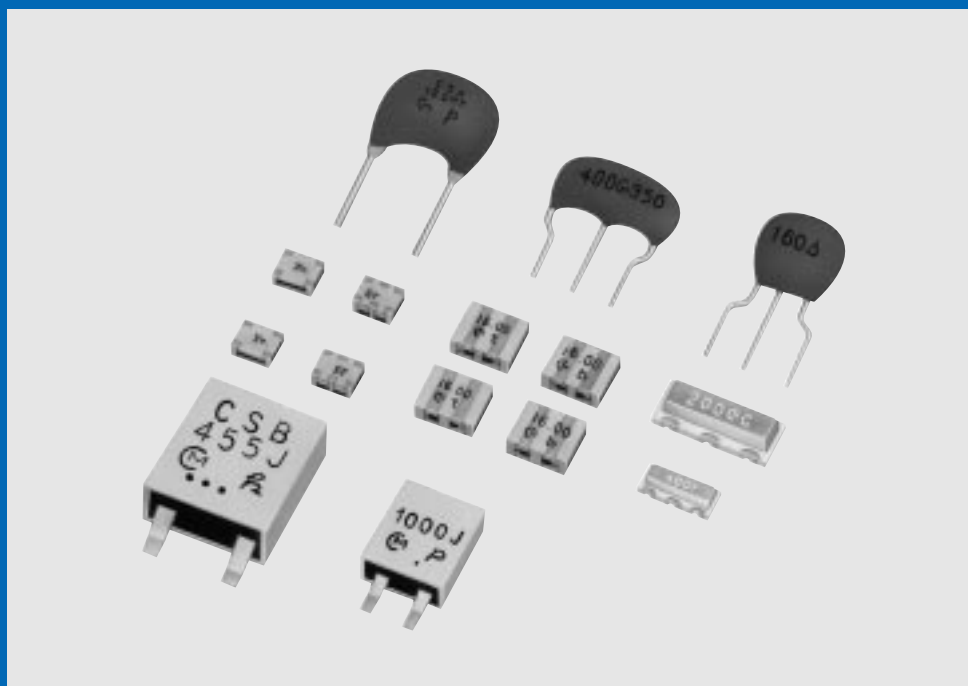

**muRata** *Innovator  
in Electronics*

Murata  
Manufacturing Co., Ltd.

Cat.No.P16E-12

# CONTENTS

CERALOCK® and "CERALOCK" in this catalog are the trademarks of Murata Manufacturing Co., Ltd.

Part Numbering	2
<b>1</b> Chip Type Three-Terminals CSTCC/E/G/R/V/W Series	3
<b>2</b> Chip Type Two-Terminals CSACV/W Series	7
● MHz Chip Type Notice (Soldering and Mounting)	10
MHz Chip Type Notice	11
MHz Chip Type CSTC Series Packaging	13
MHz Chip Type CSAC Series Packaging	15
<b>3</b> Lead Type Three-Terminals CSTLA/CSTLS Series	16
<b>4</b> Lead Type Two-Terminals CSALA/CSALS Series	18
MHz Lead type Notice	20
MHz Lead Type CSTLA/CSTLS Series Packaging	21
MHz Lead Type CSALA/CSALS Series Packaging	26
<b>5</b> Chip Type Two-Terminals CSBFB Series	28
● CSBFB_J 430-519kHz Notice (Soldering and Mounting)	30
● CSBFB_J 700-1250kHz Notice (Soldering and Mounting)	31
<b>6</b> Lead Type Two-Terminals CSBLA Series	32
● CSBLA Series Notice(Soldering and Mounting)	34
kHz CSBFB/CSBLA Series Notice	35
kHz CSBFB/CSBLA Series Packaging	36
Application Circuits Utilizing	37

● **Part Numbering** (The structure of the "Global Part Numbers" that have been adopted since June 2001 and the meaning of each code are described herein.)  
 (If you have any questions about details, inquire at your usual Murata sales office or distributor.)

**CERALOCK® (MHz)**

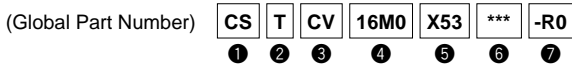

① Product ID

Product ID	
CS	Ceramic Resonators

② Frequency/Capacitance

Code	Frequency/Capacitance
A	MHz No capacitance built-in
T	MHz Built-in Capacitance

③ Structure/Size

Code	Structure/Size
LA	Lead Type
LS	Round Lead Type
CC	Cap Chip Type
CR	Small-cap Chip Type
CV	Monolithic Chip Type
CW	Small Monolithic Chip Type

④ Nominal Center Frequency

Expressed by four-digit alphanumerics. The unit is in hertz (Hz). A decimal point is expressed by the capital letter "M".

⑤ Design

Code	Design
G□□	Thickness Shear Vibration
T□□	Thickness Longitudinal Vibration
X□□	Thickness Longitudinal Vibration(3rd overtone)

□□ indicates initial frequency tolerance and load capacity.

**CERALOCK® (kHz)**

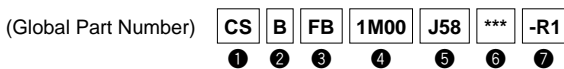

① Product ID

Product ID	
CS	Ceramic Resonators

② Frequency/Capacitance

Code	Frequency/Capacitance
B	kHz No capacitance built-in

③ Structure/Size

Code	Structure/Size
LA	Two-Terminal Lead Type
FB	SMD Type

④ Nominal Center Frequency

Expressed by four-digit alphanumerics. The unit is in hertz (Hz). If the unit is "kHz", it is expressed by three figures plus "K". If the unit is "MHz", a decimal point is expressed by the capital letter "M".

⑥ Individual Specification

Code	Individual Specification
***	Three-digit alphanumerics express "Individual Specification".

With standard products, "⑥ Individual Specification" is omitted, and "⑦ Package Specification Code" is carried up.

⑦ Packaging

Code	Packaging
-B0	Bulk
-A0	Radial Taping H <sub>0</sub> =18mm
-A1	Radial Taping H <sub>0</sub> =16mm
-R0	Plastic Taping ø=180mm
-R1	Plastic Taping ø=330mm

Radial taping is applied to lead type and plastic taping to chip type.

⑤ Design

Code	Design
E□□	Area Shear Vibration
J□□	Area Shear Vibration (Closed Type)

□□ indicates initial frequency tolerance and load capacity.

⑥ Individual Specification

Code	Individual Specification
***	Three-digit alphanumerics express "Individual Specification".

With standard products, "⑥ Individual Specification" is omitted, and "⑦ Package Specification Code" is carried up.

⑦ Packaging

Code	Packaging
-B0	Bulk
-R1	Plastic Taping ø=330mm

# Ceramic Resonators(CERALOCK®)



## Chip Type Three-Terminals CSTCC/E/G/R/V/W Series

Chip "CERALOCK" with built-in load capacitance in an extremely small package.

MURATA's package technology expertise has enabled the development of the Chip "CERALOCK" with built-in load capacitors.

High-density mounting can be realized because of the small package and the elimination of the need for an external load capacitor.

### ■ Features

1. Oscillation circuits do not require external load capacitors.
2. The series is available in a wide frequency range.
3. The resonators are extremely small and have a low profile.
4. No adjustment is necessary for oscillation circuits.

### ■ Applicatons

- Clock oscillators for microprocessors.
- Electronic control circuits for small electronic equipment such as hand held movie.
- Audio-visual applications (Camcorder, Remote Controller, etc.)
- Office automation equipments (DVD, CD-ROM, HDD, FDD, etc.)
- Automotive electronics. (CSTCC\_G\_A series, CSTCR\_G\_A series, CSTCV\_X\_A series)
- Dual Tone Multi Frequency (DTMF) generator for cordless telephones.



CSTCC\_G(A)  
2.00-3.99  
8.00-10.00MHz

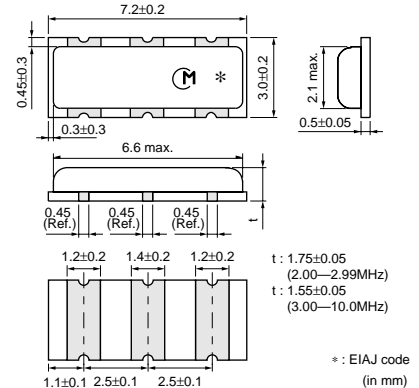

CSTCR\_G(A)  
4.00-7.99MHz

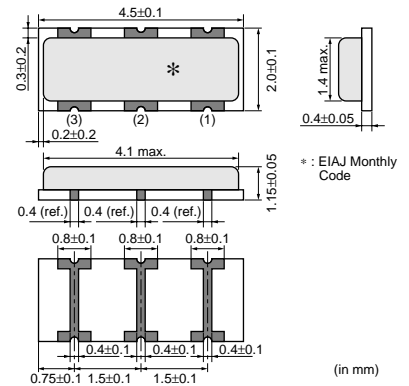

CSTCV\_T\_J  
10.01-13.49MHz  
CSTCV\_X\_J  
13.50-19.99MHz

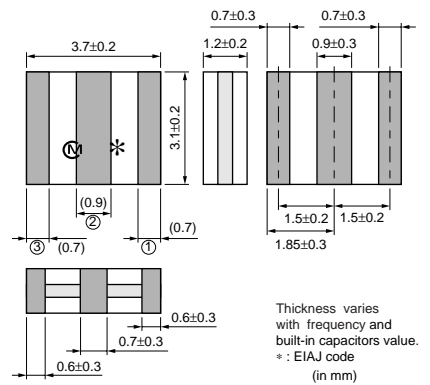

CSTCV\_X\_Q  
14.70-70.00MHz

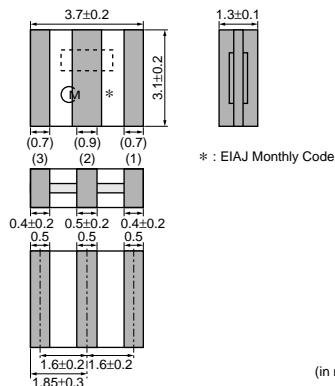

CSTCW\_X  
20.00-70.00MHz

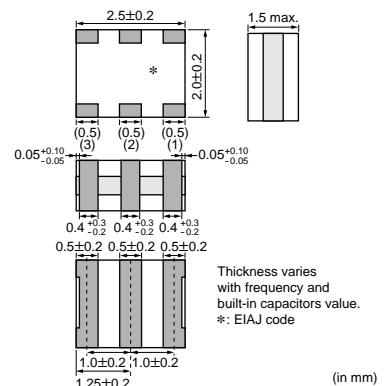

Continued on the following page. ↗

1

Continued from the preceding page.

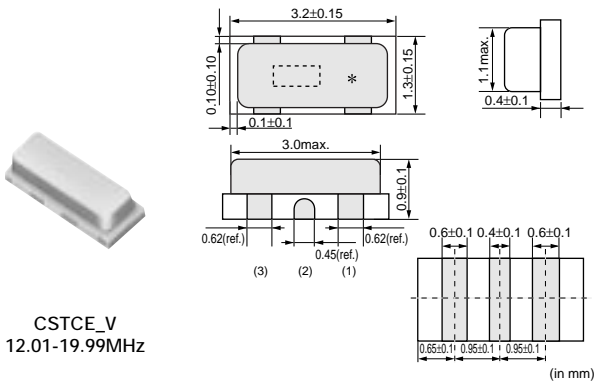

CSTCE\_V  
12.01-19.99MHz

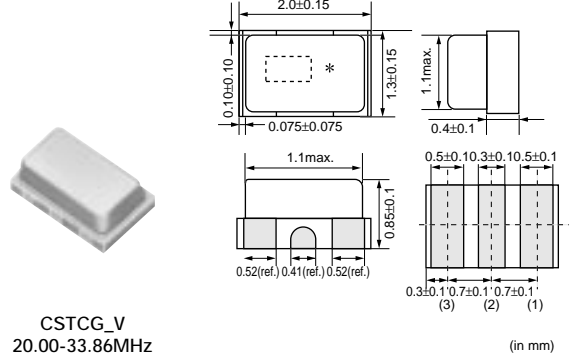

CSTCG\_V  
20.00-33.86MHz

Part Number	Oscillating Frequency (MHz)	Initial Tolerance (%)	Temp.Stability (%)	Temperature Range (°C)	Aging (10 years) (%)	Use
CSTCV_T_J	10.01 to 13.49	±0.5	±0.4	-20 to 80	±0.3	-
CSTCE_V	12.01 to 19.99	±0.5	±0.3	-20 to 80	±0.3	for ultra small electronics
CSTCV_X_J	13.50 to 19.99	±0.5	±0.3	-20 to 80	±0.3	-
CSTCV_X_Q	14.70 to 70.00	±0.5	±0.3	-40 to 125	±0.1	for automotive electronics
CSTCC_G	2.00 to 3.99, 8.00 to 10.0	±0.5	±0.3	-20 to 80	±0.3	-
CSTCC_G_A	2.00 to 3.99, 8.00 to 10.0	±0.5	±0.4	-40 to 125	±0.3	for automotive electronics
CSTCG_V	20.00 to 33.86	±0.5	±0.3	-20 to 80	±0.3	for ultra small electronics
CSTCW_X	20.00 to 70.00	±0.5	±0.2	-20 to 80	±0.1	-
CSTCR_G	4.00 to 7.99	±0.5	±0.2	-20 to 80	±0.1	-
CSTCR_G_A	4.00 to 7.99	±0.5	±0.3	-40 to 125	±0.1	for automotive electronics

Irregular or stop oscillation may occur under unmatched circuit conditions. Please check the actual conditions prior to use.

### ■ Oscillation Frequency Measuring Circuit

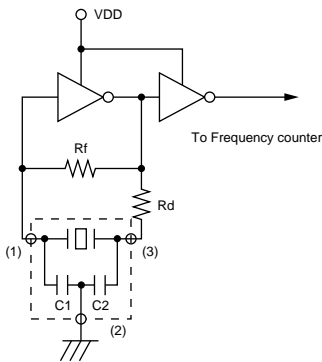

■ Standard Land Pattern Dimensions

CSTCC\_G(A) (2.00-3.99, 8.00-10.00MHz)

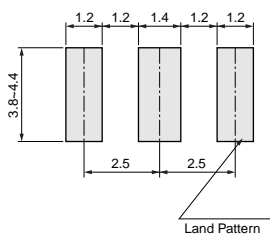

(in mm)

CSTCR\_G(A) (4.00-7.99MHz)

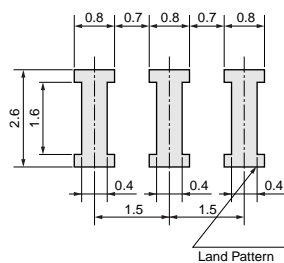

(in mm)

CSTCV\_T\_J (10.01-13.49MHz)/CSTCV\_X\_J (13.50-19.99MHz)

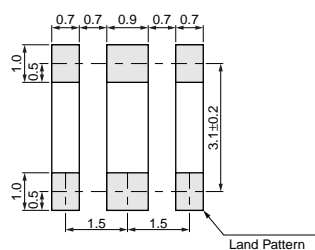

(in mm)

CSTCV\_X\_Q (14.70-70.00MHz)

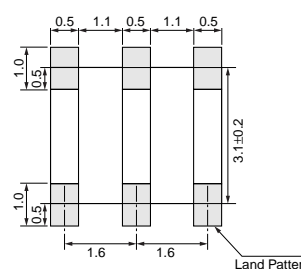

(in mm)

CSTCW\_X (20.00-70.00MHz)

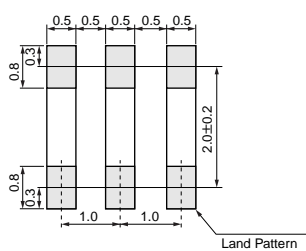

(in mm)

■ Standard Land Pattern Dimensions

CSTCE\_V (12.01-19.99MHz)

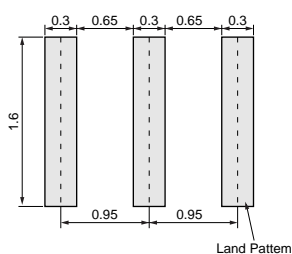

(in mm)

CSTCG\_V (20.00-33.86MHz)

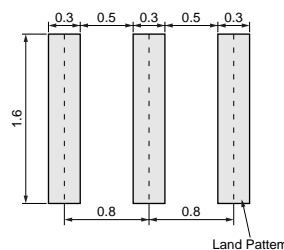

(in mm)

## ■ Oscillation Frequency Temperature Stability

CSTCC\_G(A)

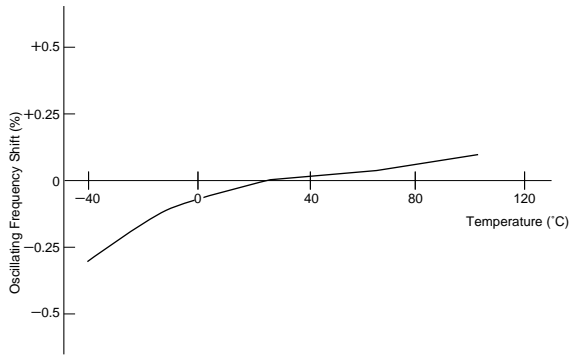

CSTCR\_G(A)

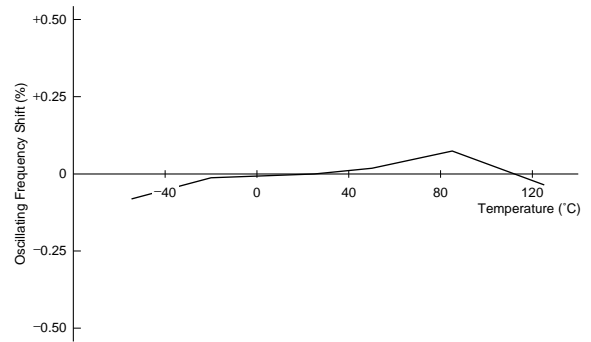

CSTCV\_T\_J

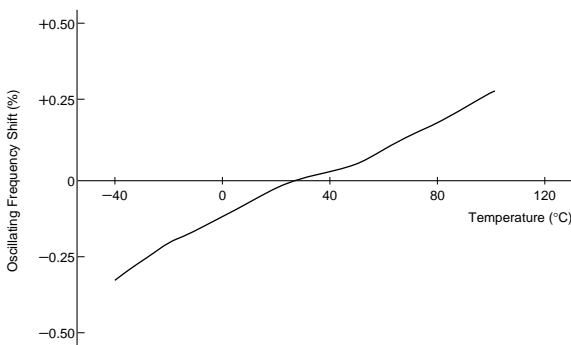

CSTCV\_X\_J

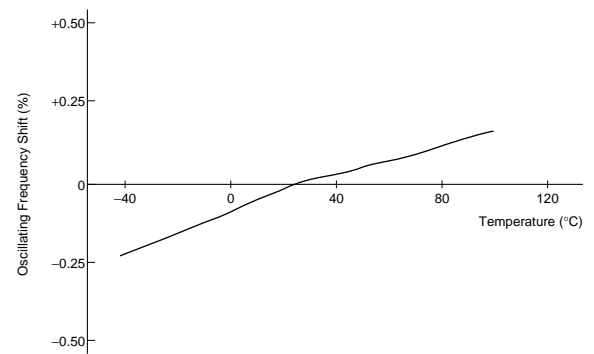

CSTCV\_X\_Q

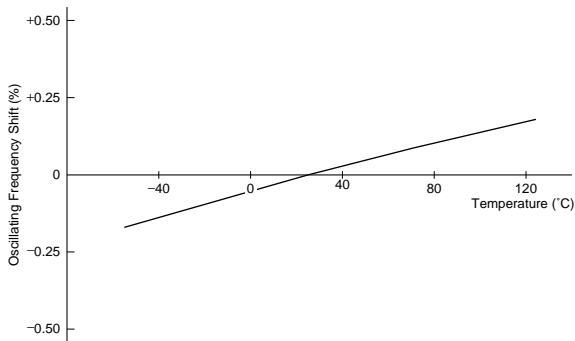

CSTCW\_X

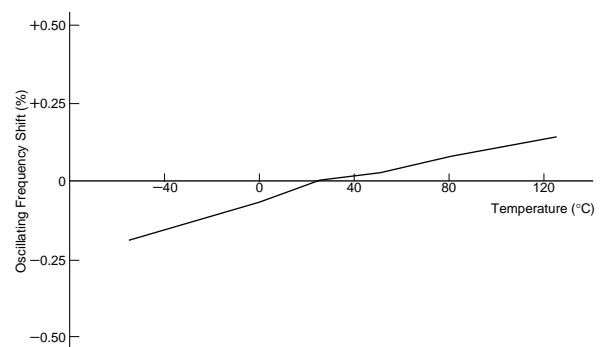

CSTCE\_V

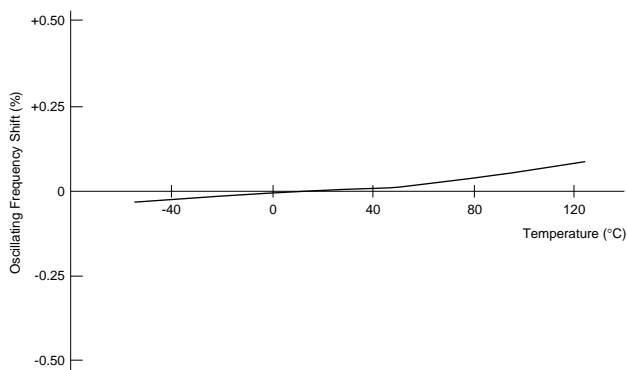

CSTCG\_V

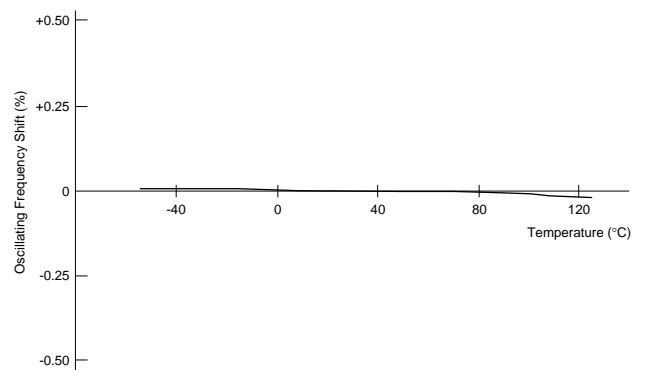

# Ceramic Resonators(CERALOCK®)



## Chip Type Two-Terminals CSACV/W Series

Wide range of chip "CERALOCK" is now available. This diverse series owes its development to MURATA's package technology expertise and original mass production techniques. It enables high-density mounting and further miniaturization of electronic equipment.

### ■ Features

1. The series is available in a wide frequency range.
2. The resonators are extremely small and have a low profile. (CSACV series)
3. No adjustment is necessary for oscillation circuits.

### ■ Applications

- Clock oscillators for microprocessors.
- Electronic control circuits for small electronic equipment.
- Automotive electronics. (CSACV\_X\_A series)



CSACV\_T\_J  
10.01-13.49MHz

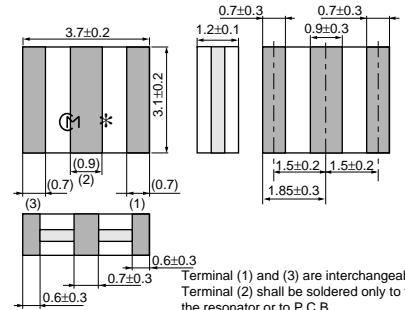

Terminal (1) and (3) are interchangeable. Terminal (2) shall be soldered only to fix the resonator or to P.C.B. Terminal (2) shall be electrically floating so it shall not be connected to anywhere. Thickness varies with frequency. \*: EIAJ code (in mm)



CSACV\_X\_J  
13.50-19.99MHz

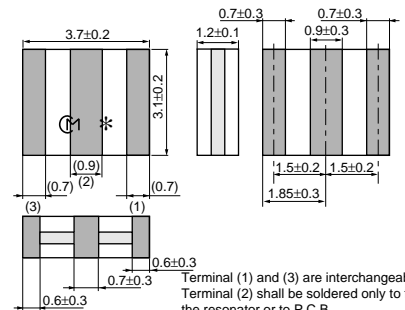

Terminal (1) and (3) are interchangeable. Terminal (2) shall be soldered only to fix the resonator or to P.C.B. Terminal (2) shall be electrically floating so it shall not be connected to anywhere. Thickness varies with frequency. \*: EIAJ code (in mm)



CSACV\_X\_Q  
14.70-70.00MHz

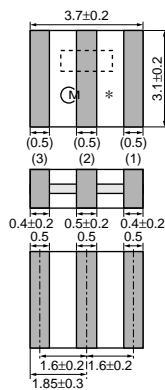

Terminal (1) and (3) are interchangeable. Terminal (2) shall be soldered only to fix the resonator on to P.C.B. Terminal (2) shall be electrically floating so it shall not be connected to anywhere.

\*: EIAJ Monthly Code

(in mm)



CSACW\_X  
20.00-70.00MHz

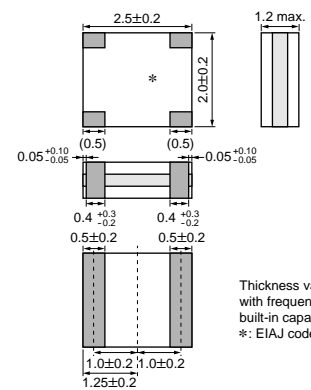

Thickness varies with frequency and built-in capacitors value. \*: EIAJ code

(in mm)

Part Number	Oscillating Frequency (MHz)	Initial Tolerance (%)	Temp.Stability (%)	Temperature Range (°C)	Aging (10 years) (%)	Use
CSACV_T_J	10.01 to 13.49	±0.5	±0.5	-20 to 80	±0.5	-
CSACV_X_J	13.50 to 19.99	±0.5	±0.3	-20 to 80	±0.3	-
CSACV_X_Q	14.70 to 70.00	±0.5	±0.3	-40 to 125	±0.1	for automotive electronics
CSACW_X_53	20.00 to 24.99	±0.5	±0.2	-20 to 80	±0.1	-
CSACW_X_51	25.00 to 70.00	±0.5	±0.2	-20 to 80	±0.1	-

Irregular or stop oscillation may occur under unmatched circuit conditions. Please check the actual conditions prior to use.

## ■ Oscillation Frequency Measuring Circuit

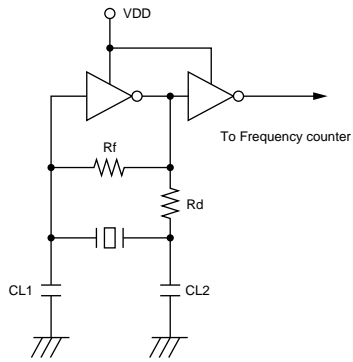

2

## ■ Standard Land Pattern Dimensions

CSACV\_T\_J 10.01-13.49MHz/CSACV\_X\_J 13.50-19.99MHz

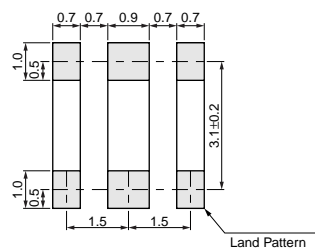

(in mm)

CSACV\_X\_Q 14.70-70.00MHz

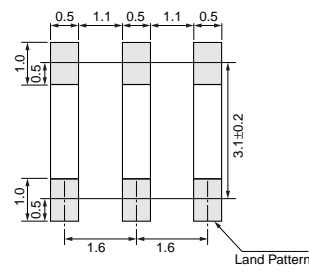

(in mm)

CSACW\_X 20.00-70.00MHz

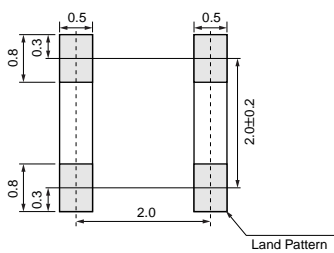

(in mm)

## ■ Oscillation Frequency Temperature Stability

CSACV\_T\_J

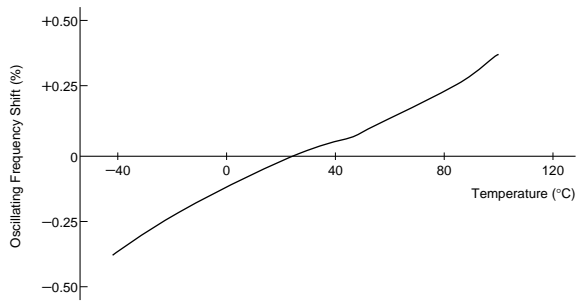

CSACV\_X\_J

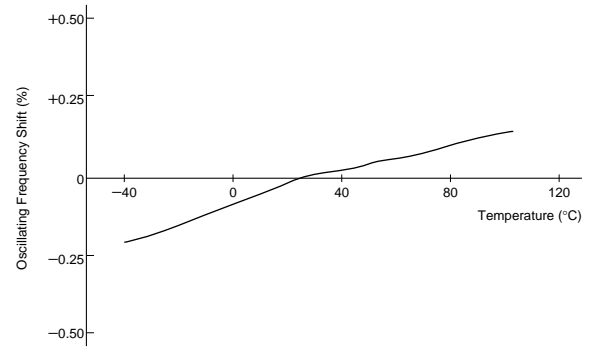

CSACV\_X\_Q

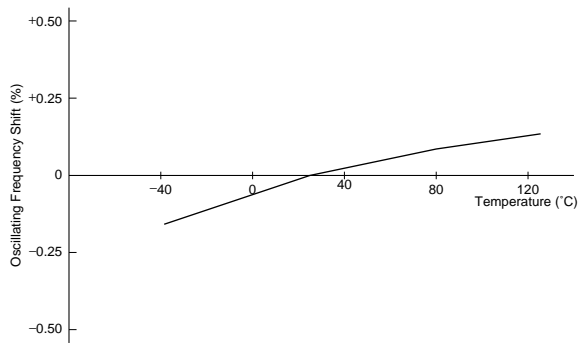

CSACW\_X

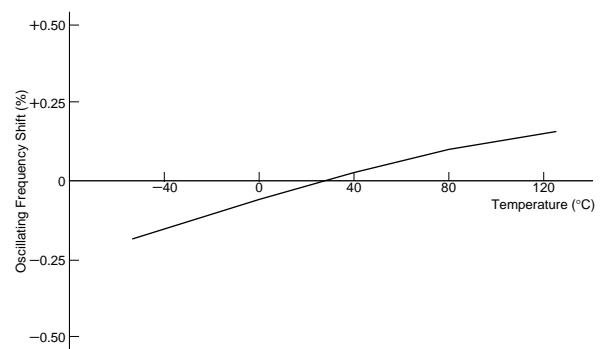

2

## MHz Chip Type Notice (Soldering and Mounting)

2

### 1. Soldering Condition

#### (1) Reflow

Following profile of heat stress 1 times is applied to resonator, then being place in natural condition for 1 hour, resonator shall be measure.

1. Pre-heating conditions shall be +140 to +160°C for 60 to 120 seconds. Ascending time up to +150°C shall be longer than 30 second.
2. Heating conditions shall be within 20 seconds at +230°C min., but peak temperature shall be lower than +240°C.

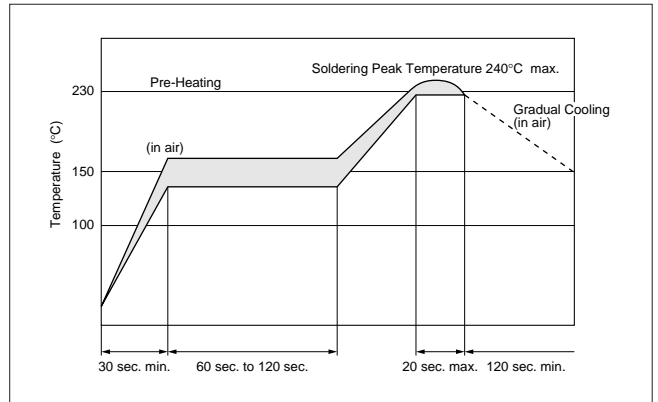

#### (2) Soldering Iron

Soldering iron of +270±5°C shall be placed 0.5mm above from electrode of resonator. Melting solder through soldering iron shall be applied to electrode for 3±1 seconds, then being place in natural condition for 24 hour, resonator shall be measured.

### 2. Wash

Some series are not withstand washing. Please check the right list before use.

#### (1) Cleaning Solvent

HCFC, Isopropanol, Tap water, Demineralized water, Cleanthrough750H, Pine alpha 100S, Techno care FRW

#### (2) Temperature Difference : $\Delta T$ \*1

$\Delta T \leq 60^\circ\text{C}$  ( $\Delta T = \text{Component} - \text{solvent}$ )

\*1 ex. In case the component at +90°C immerses into cleaning solvent at +60°C, then  $\Delta T = 30^\circ\text{C}$ .

Series	Wash
<b>CSTCC (Except 2.00-3.49MHz)</b>	Available
<b>CSTCV</b>	Available
<b>CSACV</b>	Available
<b>CSTCR</b>	Not Available
<b>CSTCC (Only 2.00-3.49MHz)</b>	Not Available
<b>CSTCW</b>	Not Available
<b>CSACW</b>	Not Available
<b>CSTCE</b>	Not Available
<b>CSTCG</b>	Not Available

#### (3) Condition

##### 1. Ultrasonic Wash

1 minute max. in above solvent at +60°C max.  
(Frequency : 28kHz, Output : 20W/L)

##### 2. Immersion Wash

5 minutes max. in above solvent at +60°C max.

##### 3. Shower or Rinse Wash

5 minutes max. in above solvent at +60°C max.

#### (4) Drying

5 minutes max. by air blow at +80°C max.

#### (5) Others

1. Total washing time should be within 10 minutes.
2. Please insure the component is thoroughly evaluated in your application circuit.
3. The component may be damaged if it is washed with chlorine, petroleum, or alkali cleaning solvent.

## MHz Chip Type Notice

### ■ Notice (Storage and Operating Conditions)

#### CSTCC\_G

Please do not apply excess mechanical stress to the component and terminals at soldering.

The component is recommended with placement machines with employ optical placement capabilities.

The component might be resulted in damage by excessivemechanical force. Please make sure that you have evaluated by using placementmachines before going into mass production. Do not use placement machines whichutilize mechanical positioning. Please contact Murata for details beforehand.

#### 1. CSTCC\_G(2.00MHz-3.49MHz)

Conformal coating or washing to the component is not acceptable. Because it is not hermetically sealed.

#### 2. CSTCC\_G(3.50MHz-10.0MHz)

Conformal coating of the component is acceptable. However, the resin material, curing temperature, and other process conditions should be evaluated to confirm stable electrical characteristics are maintained.

### ■ Notice (Storage and Operating Conditions)

#### CSTCC\_G\_A/CSTCR\_G\_A

Please do not apply excess mechanical stress to the component and terminals at soldering.

Conformal coating of the component is acceptable.

However, the resin material, curing temperature, and other process conditions should be evaluated to confirm stable electrical characteristics are maintained.

The component is recommended with placement machines

with employ optical placement capabilities.

The component might be resulted in damage by excessivemechanical force. Please make sure that you have evaluated by using placementmachines before going into mass production. Do not use placement machines whichutilize mechanical positioning. Please contact Murata for details beforehand.

### ■ Notice (Storage and Operating Conditions)

#### CSTCV\_T\_J/CSTCV\_X\_J/CSACV\_T\_J/CSACV\_X\_J

Please do not apply excess mechanical stress to the component and terminals at soldering.

Conformal coating of the component is acceptable.

However, the resin material, curing temperature, and other process conditions should be evaluated to confirm stable electrical characteristics are maintained.

### ■ Notice (Storage and Operating Conditions)

#### CSTCV\_X\_Q/CSACV\_X\_Q

Please do not apply excess mechanical stress to the component and terminals at soldering.

Conformal coating of the component is acceptable.

However, the resin material, curing temperature, and other process conditions should be evaluated to confirm stable electrical characteristics are maintained.

The component is recommended with placement machines which employ optical placement capabilities. In some cases, placement machines which utilize mechanical positioning may apply excessive mechanical force which might result in damage to the ceramic resonator. Please contact Murata before mounting this product using placement machines which use mechanical positioning.

### ■ Notice (Storage and Operating Conditions)

#### CSTCW\_X/CSACW\_X

Please do not apply excess mechanical stress to the component and terminals at soldering.

Conformal coating or washing to the component is not acceptable. Because it is not hermetically sealed.

## MHz Chip Type Notice

### ■ Notice (Storage and Operating Conditions)

CSTCE\_V/CSTCG\_V/CSTCR\_G

Please do not apply excess mechanical stress to the component and terminals at soldering.

Conformal coating or washing to the component is not acceptable. Because it is not hermetically sealed.

The component is recommended with placement machines with employ optical placement capabilities.

The component might be resulted in damage by excessivemechanical force. Please make sure that you have evaluated by using placementmachines before going into mass production. Do not use placement machines whichutilize mechanical positioning. Please contact Murata for details beforehand.

### ■ Notice (Rating)

The component may be damaged if excess mechanical stress is applied.

### ■ Notice (Handling)

"CERLOCK" may stop oscillating or oscillate irregularly under improper circuit conditions.

# MHz Chip Type CSTC Series Packaging

## Minimum Quantity

Part Number	Plastic Tape ø180mm	Plastic Tape ø330mm	Bulk	Dimensions
CSTCC_G	2,000	6,000	500	a
CSTCC_G_A	2,000	6,000	500	a
CSTCR_G	3,000	9,000	500	a
CSTCR_G_A	3,000	9,000	500	a
CSTCV_T_J	2,000	6,000	500	a
CSTCV_X_J	2,000	6,000	500	a
CSTCV_X_Q	2,000	6,000	500	a
CSTCW_X	3,000	9,000	500	b
CSTCE_V	3,000	9,000	500	b
CSTCG_V	3,000	9,000	500	b

The order quantity should be an integral multiple of the "Minimum Quantity" shown above.

(pcs.)

## Dimensions of Reel

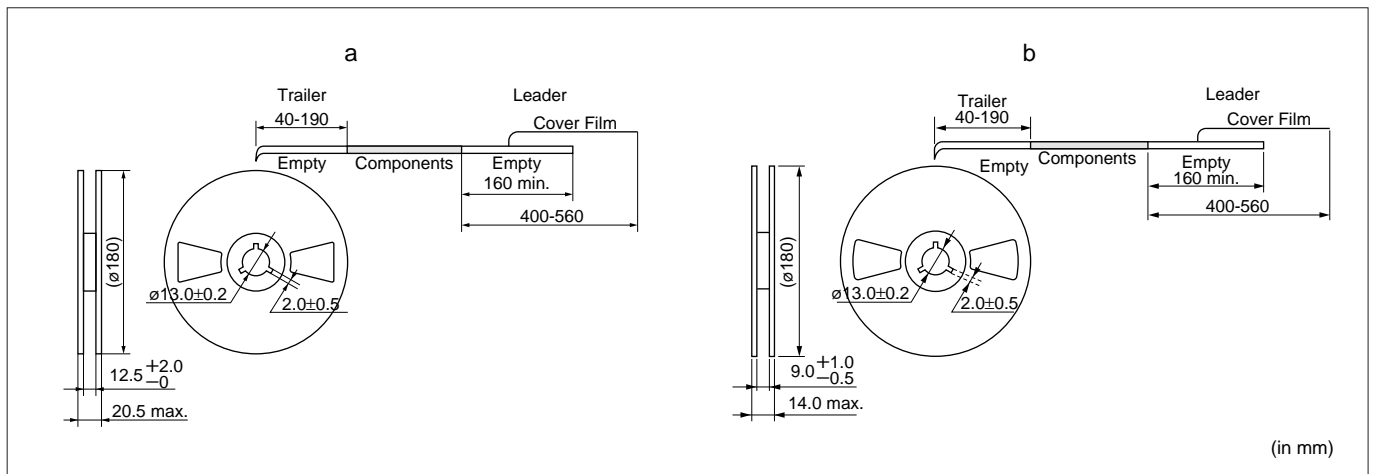

(in mm)

## Dimensions of Taping

CSTCC\_G(A) less than 3.00MHz

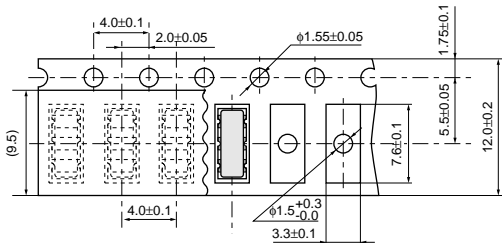

The cover film peel strength force 0.1 to 0.7N  
The cover film peel speed 300mm/min.

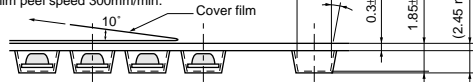

(in mm)

CSTCC\_G(A) more than 3.00MHz

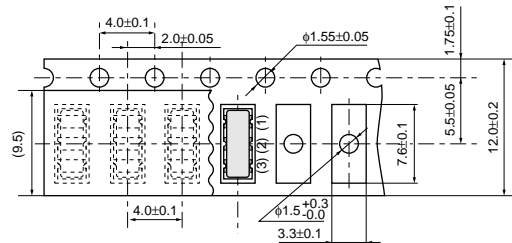

The cover film peel strength force 0.1 to 0.7N  
The cover film peel speed 300mm/min.

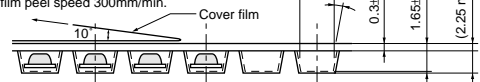

(in mm)

Continued on the following page. ↗

# MHz Chip Type CSTC Series Packaging

Continued from the preceding page.

## Dimensions of Taping

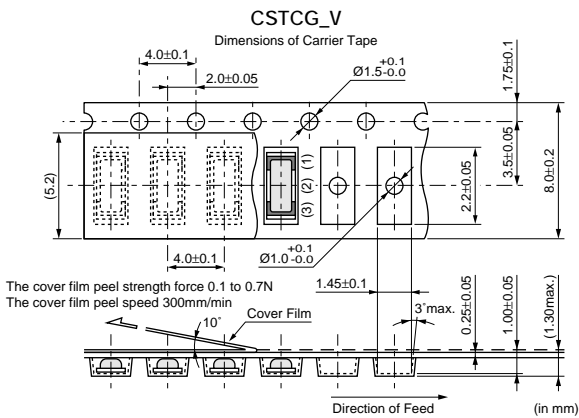
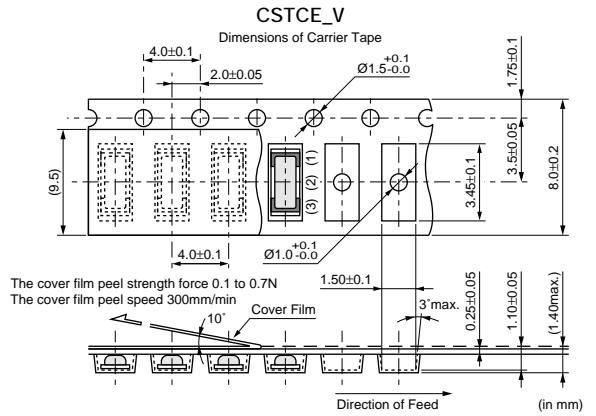
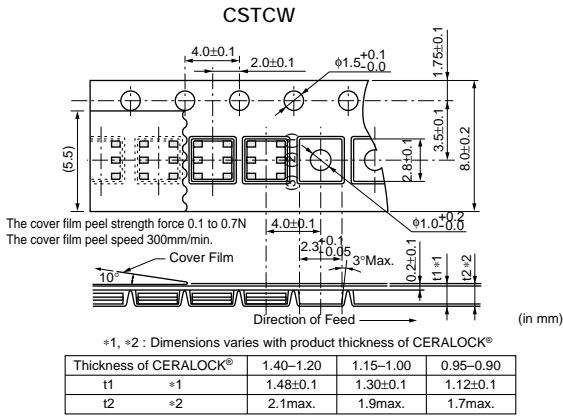
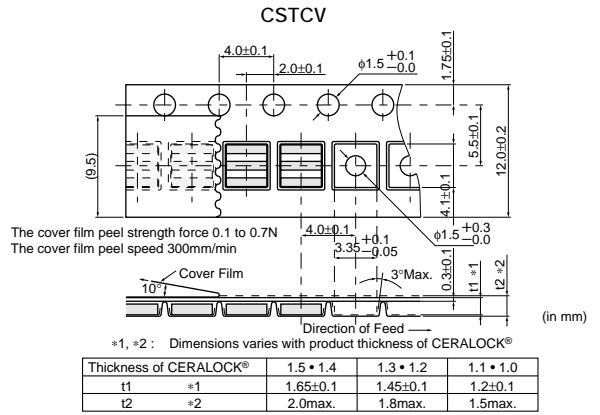
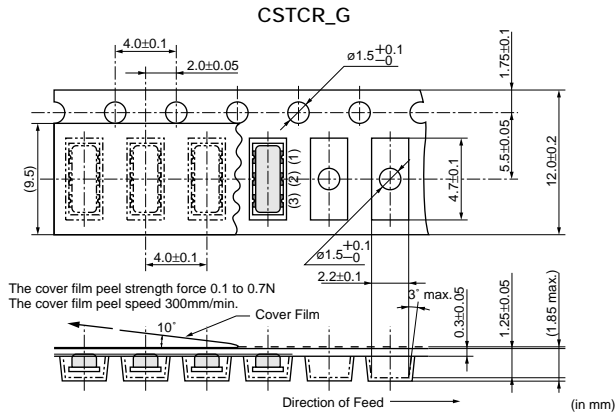

# MHz Chip Type CSAC Series Packaging

## Minimum Quantity

Part Number	Plastic Tape ø180mm	Plastic Tape ø330mm	Bulk	Dimensions
CSACV_T_J	2,000	6,000	500	a
CSACV_X_J	2,000	6,000	500	a
CSACV_X_Q	2,000	6,000	500	a
CSACW_X	3,000	9,000	500	b

The order quantity should be an integral multiple of the "Minimum Quantity" shown above.

(pcs.)

## Dimensions of Reel

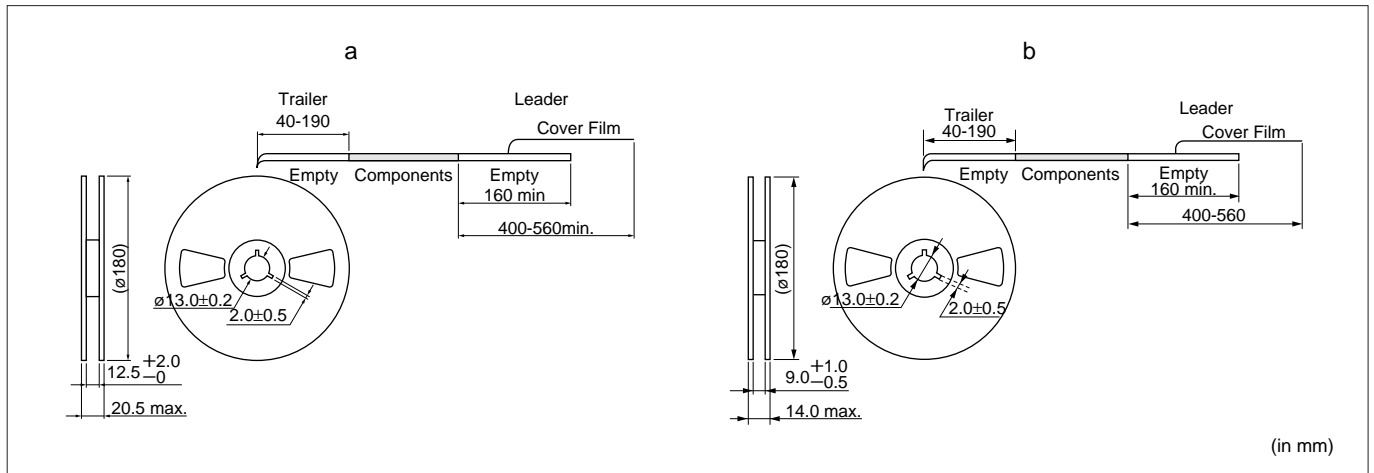

(in mm)

## Dimensions of Taping

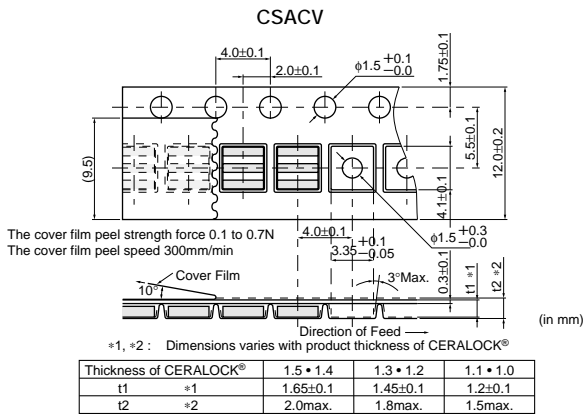

(in mm)

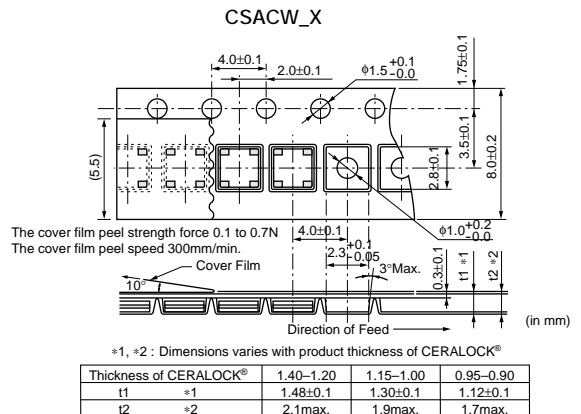

(in mm)

# Ceramic Resonators(CERALOCK®)



## Lead Type Three-Terminals CSTLA/CSTLS Series

3

"CERALOCK" with built-in load capacitors. MURATA's ceramic resonator, "CERALOCK", has been widely applied as the most suitable component for clock oscillators in a broad range of microprocessors. The CSTLS series (MHz band) and CSTLA series (MHz band) can be used in the design of oscillation circuits not requiring external load capacitors, enabling both high-density mounting and cost reduction.

### ■ Features

1. Oscillation circuits do not require external load capacitors.
2. The series is stable over a wide temperature range.
3. The resonators are compact, light weight and exhibit superior shock resistance performance.
4. They enable the design of oscillator circuits requiring no adjustment.
5. The series is inexpensive and available in stable supply.
6. There are some variation of built-in capacitance value to apply various of IC.

### ■ Applications

- DTMF generators.
- Clock oscillators for microcomputers.
- Automotive electronics.  
(Suffixed "A" ex. CSTLS\_G\_A)
- Remote control units.
- Automated office equipment.

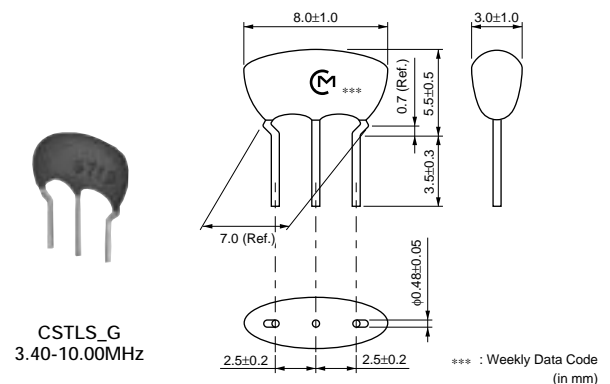
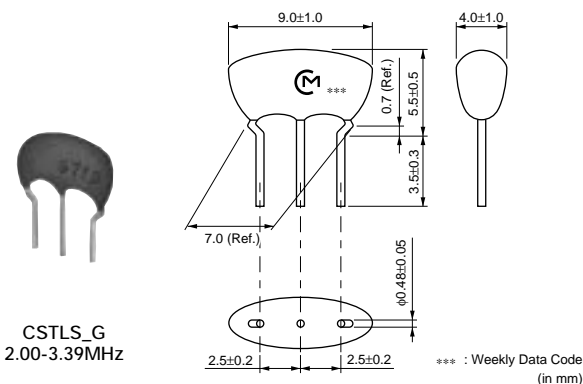
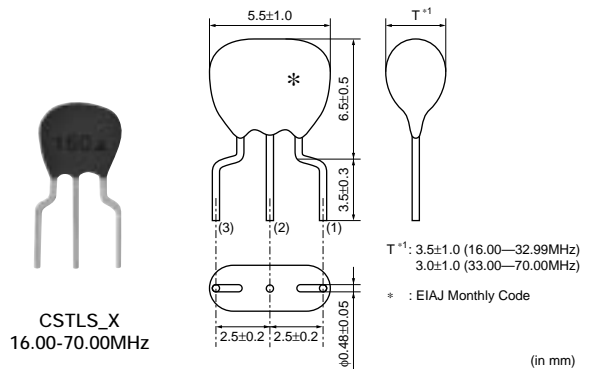
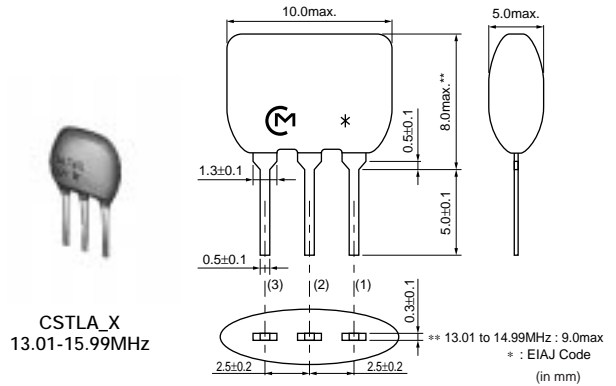
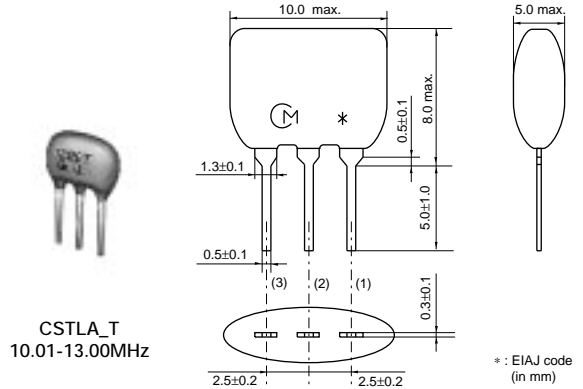

Part Number	Oscillating Frequency (MHz)	Initial Tolerance (%)	Temp.Stability (%)	Temperature Range (°C)	Aging (10 years) (%)	Use
<b>CSTLA_T</b>	10.01 to 13.00	±0.5	±0.4	-20 to 80	±0.3	-
<b>CSTLA_X</b>	13.01 to 15.99	±0.5	±0.3	-20 to 80	±0.3	-
<b>CSTLS_X</b>	16.00 to 70.00	±0.5	±0.2	-20 to 80	±0.2	-
<b>CSTLS_G</b>	2.00 to 3.39	±0.5	±0.2	-20 to 80	±0.2	-
<b>CSTLS_G</b>	3.40 to 10.00	±0.5	±0.2	-20 to 80	±0.2	-

Irregular or stop oscillation may occur under unmatched circuit conditions. Please check the actual conditions prior to use.  
The order quantity should be an integral multiple of the Minimum Quantity shown in the packaging page.

### ■ Oscillation Frequency Measuring Circuit

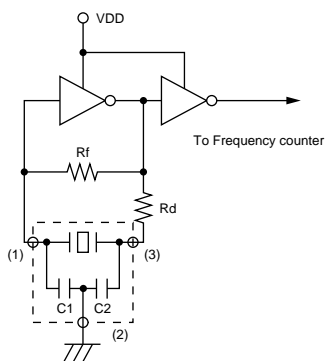

### ■ Oscillation Frequency Temperature Stability

CSTLA\_T

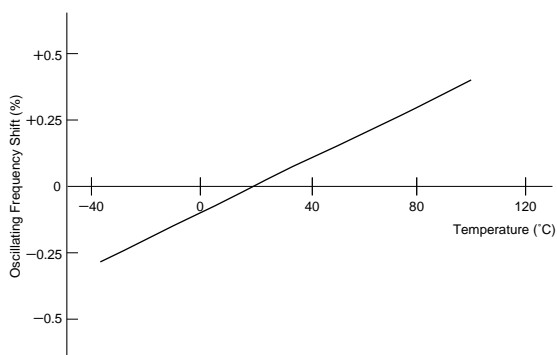

CSTLA\_X

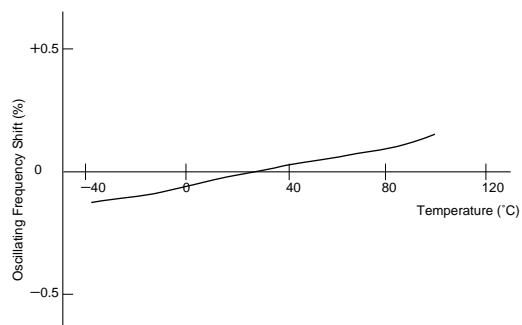

CSTLS\_G

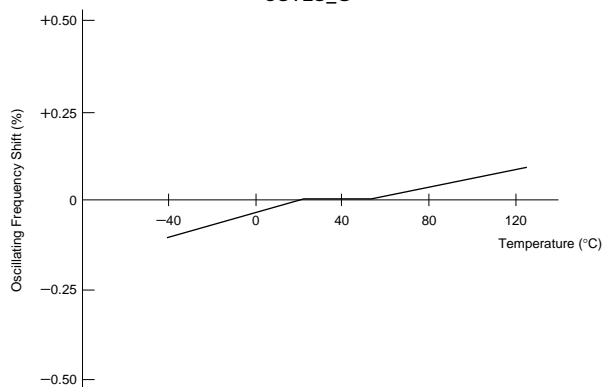

CSTLS\_X

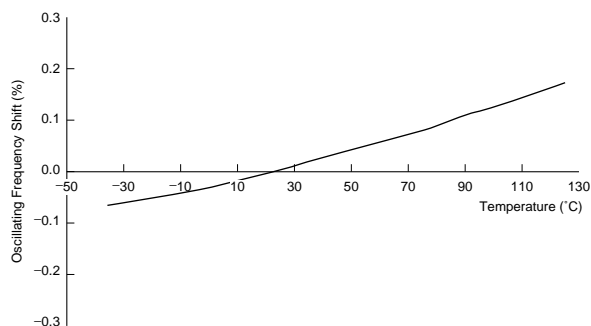

# Ceramic Resonators(CERALOCK<sup>®</sup>)



## Lead Type Two-Terminals CSALA/CSALS Series

"CERALOCK" with two leaded terminals.  
 The CSALA and CSBLA series ceramic resonator owe their development to MURATA's innovative expert technologies and the application of mass production techniques typically utilized in the manufacture of piezoelectric ceramic components. Because of their high mechanical Q and consistent high quality, both the CSALA and CSBLA series are ideally suited to microprocessor and remote control unit applications. The CSBLA series includes the thin and compact J type which is ideal in high-speed 4-bit microprocessor applications.  
 In addition, MURATA offers a special "CERALOCK" version suitable for automatic insertion utilizing tape and reel and other packaging forms. For further information, please contact your local MURATA representative office or authorized distributor.

### ■ Features

1. The series is stable over a wide temperature range and with respect to long-term aging.
2. The series comprises fixed, tuned, solid-state devices.
3. The resonators are miniature and light weight.
4. They exhibit excellent shock resistance performance.
5. Oscillating circuits requiring no adjustment can be designed by utilizing these resonators in conjunction with transistors or appropriate ICs.

### ■ Applications

- Square-wave and sine-wave oscillator.
- Clock generator for microprocessors.
- Remote control systems.

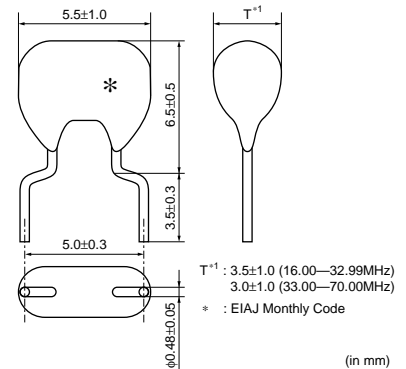
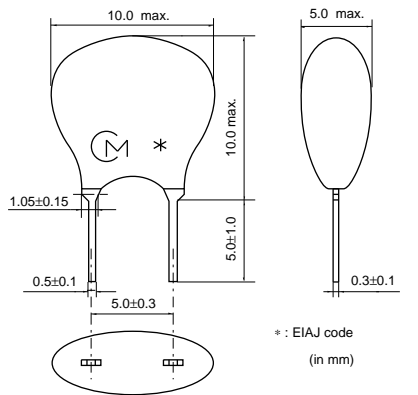
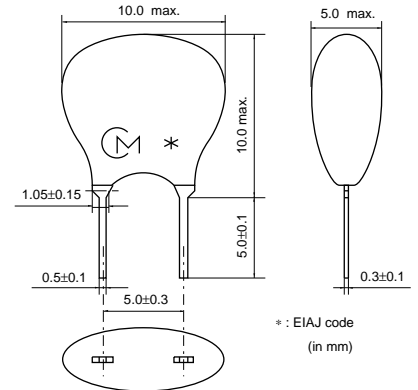

Part Number	Oscillating Frequency (MHz)	Initial Tolerance (%)	Temp.Stability (%)	Temperature Range (°C)	Aging (10 years) (%)	Use
CSALA_T	10.01 to 13.00	±0.5	±0.5	-20 to 80	±0.5	-
CSALA_X	13.01 to 15.99	±0.5	±0.3	-20 to 80	±0.3	-
CSALS_X	16.00 to 70.00	±0.5	±0.2	-20 to 80	±0.2	-

Irregular or stop oscillation may occur under unmatched circuit conditions. Please check the actual conditions prior to use.  
 The order quantity should be an integral multiple of the Minimum Quantity shown in the packaging page.

## ■ Oscillation Frequency Measuring Circuit

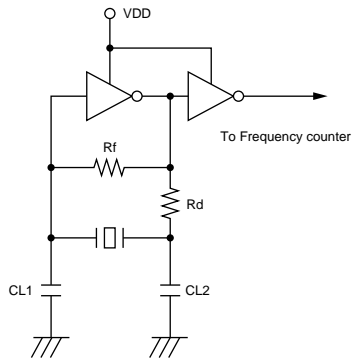

## ■ Oscillation Frequency Temperature Stability

CSALA\_T

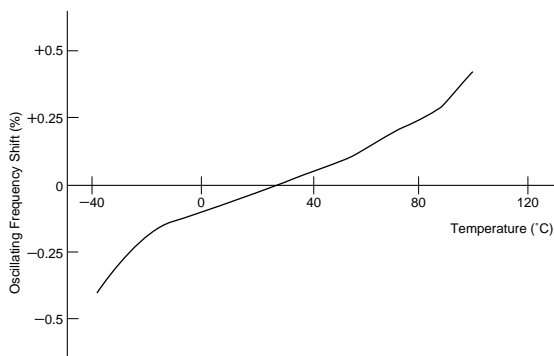

CSALA\_X

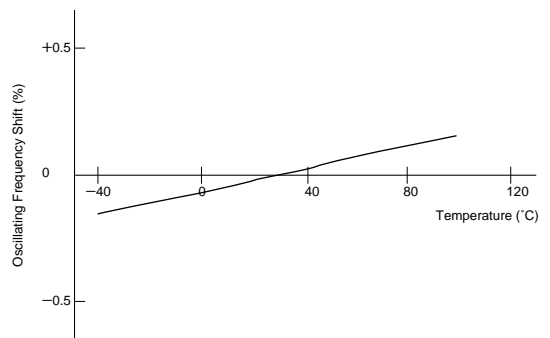

CSALS\_X

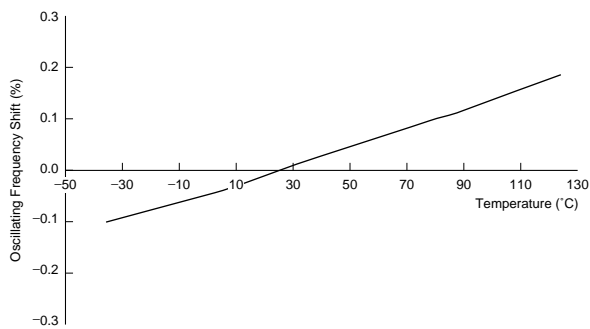

## MHz Lead type Notice

### ■ Notice (Soldering and Mounting)

CSTLA\_T/CSTLA\_X/CSALA\_T/CSALA\_X

#### (1)Cleaning Solvent

HCFC, Isopropanol, Tap water, Demineralized water,  
Cleanthrough750H, Pine alpha 100S, Techno care FRW

#### (2)Condition

1. Ultrasonic Wash  
1 minute max. in above solvent at +60°C max.  
(Frequency:28kHz, Output:20W/L)
2. Immersion Wash  
5 minutes max. in above solvent at +60°C max.
3. Shower or Rinse Wash  
5 minutes max. in above solvent at +60°C max.

#### (3)Drying

5 minutes max. by air blow at +80°C max.

#### (4)Others

1. In case of immersing in cleaning solvent, the temperature of component must be returned to room temperature after soldering
2. Total washing time should be within 10 minutes.
3. Please insure the component is thoroughly evaluated in your application circuit.
4. The component may be damaged if it is washed with chlorine, petroleum or alkali cleaning solvent.

### ■ Notice (Soldering and Mounting)

CSTLS\_G/CSTLS\_X/CSALS\_X

The component cannot be withstand washing.

### ■ Notice (Storage and Operating Conditions)

CSTLA\_T/CSTLA\_X/CSALA\_T/CSALA\_X

Please do not apply excess mechanical stress to the component and lead terminals at soldering.

Conformal coating of the component is acceptable.

However, the resin material, curing temperature, and other process conditions should be evaluated to confirm stable electrical characteristics are maintained.

### ■ Notice (Storage and Operating Conditions)

CSTLS\_G/CSTLS\_X/CSALS\_X

Please do not apply excess mechanical stress to the component and lead terminals at soldering.

Conformal coating or washing to the component is not acceptable. Because it is not hermetically sealed.

### ■ Notice (Rating)

The component may be damaged if excess mechanical stress is applied.

### ■ Notice (Handling)

"CERLOCK" may stop oscillating or oscillate irregularly under improper circuit conditions.

## MHz Lead Type CSTLA/CSTLS Series Packaging

### ■ CSTLA/CSTLS Series Minimum Quantity

Part Number	Ammo Pack	Bulk
CSTLA_T (10.01 to 13.00MHz)	1,000	500
CSTLA_X (13.01 to 15.99MHz)	1,000	500
CSTLS_X (16.00 to 70.00MHz)	2,000	500
CSTLS_G (2.00 to 3.39MHz)	1,500	500
CSTLS_G (3.40 to 10.0MHz)	2,000	500

The order quantity should be an integral multiple of the "Minimum Quantity" shown above.

(pcs.)

### ■ Tape Dimensions of CSTLA\_T

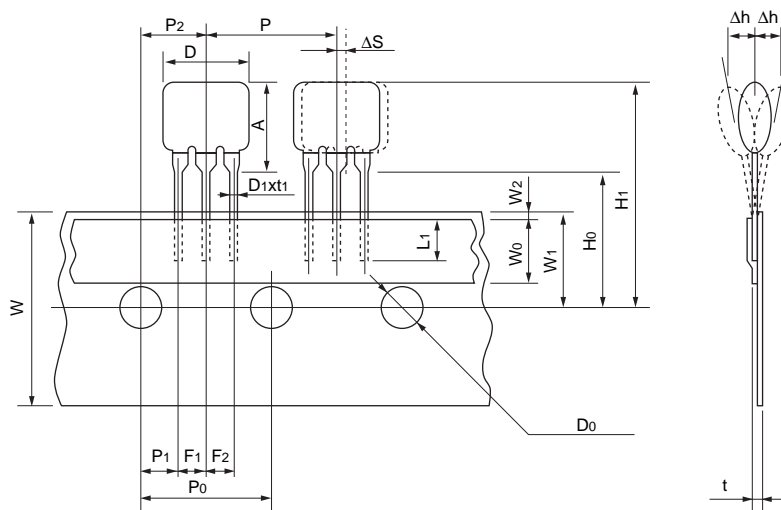

Item	Code	Dimensions	Tolerance	Remarks
Width of diameter	D	10.0 max.	-	
Height of resonator	A	8.0 max.	-	
Dimensions of terminal	D <sub>1</sub> × t <sub>1</sub>	0.5 × 0.3	±0.1	
Lead length under the hold down tape	L <sub>1</sub>	3.0 min.	-	
Pitch of component	P	12.7	±0.5	Tolerance for pitches 10 × P <sub>0</sub> = 127 ± 1
Pitch of sprocket hole	P <sub>0</sub>	12.7	±0.2	
Length from sprocket hole center to lead	P <sub>1</sub>	3.85	±0.5	
Length from sprocket hole center to component center	P <sub>2</sub>	6.35	±0.5	
Lead spacing (I)	F <sub>1</sub>	2.5	±0.2	
Lead spacing (II)	F <sub>2</sub>	2.5	±0.2	
Slant to the forward or backward	Δh	0	±1.0	1mm max.
Width of carrier tape	W	18.0	±0.5	
Width of hold down tape	W <sub>0</sub>	6.0 min.	-	Hold down tape doesn't exceed the carrier tape.
Position of sprocket hole	W <sub>1</sub>	9.0	±0.5	
Gap of hold down tape and carrier tape	W <sub>2</sub>	0	+0.5 -0	
Distance between the center of sprocket hole and lead stopper	H <sub>0</sub>	18.0	±0.5	
Total height of resonator	H <sub>1</sub>	26.5 max.	-	
Diameter of sprocket hole	D <sub>0</sub>	∅4.0	±0.2	
Total tape thickness	t	0.6	±0.2	
Body tilt	ΔS	0	±1.0	

(in mm)

Continued on the following page.

## MHz Lead Type CSTLA/CSTLS Series Packaging

Continued from the preceding page.

### ■ Tape Dimensions of CSTLA\_X

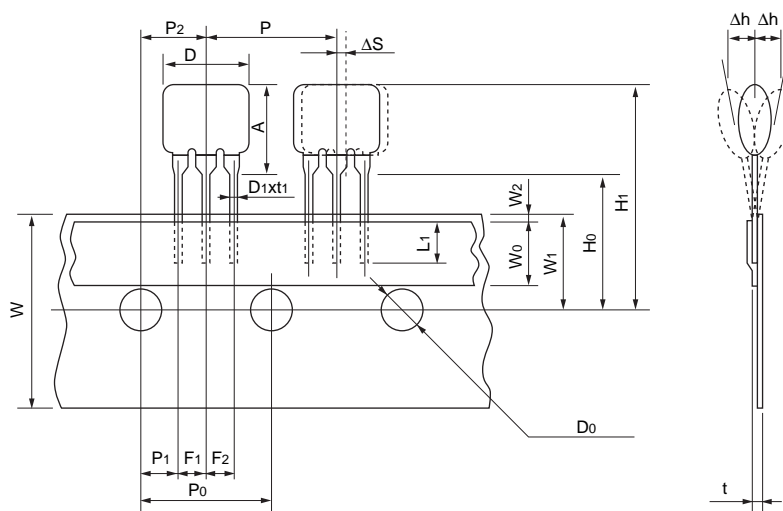

Item	Code	Dimensions	Tolerance	Remarks
Width of diameter	D	10.0 max.	-	
Height of resonator	A	8.0 max.	-	13.01 to 14.99MHz : 9.0 max.
Dimensions of terminal	D1x1	0.5x0.3	±0.1	
Lead length under the hold down tape	L1	3.0 min.	-	
Pitch of component	P	12.7	±0.5	Tolerance for pitches 10xP0=127±1
Pitch of sprocket hole	P0	12.7	±0.2	
Length from sprocket hole center to lead	P1	3.85	±0.5	
Length from sprocket hole center to component center	P2	6.35	±0.5	
Lead spacing (I)	F1	2.5	±0.2	
Lead spacing (II)	F2	2.5	±0.2	
Slant to the forward or backward	Δh	0	±1.0	1mm max.
Width of carrier tape	W	18.0	±0.5	
Width of hold down tape	W0	6.0 min.	-	Hold down tape doesn't exceed the carrier tape.
Position of sprocket hole	W1	9.0	±0.5	
Gap of hold down tape and carrier tape	W2	0	+0.5 -0	
Distance between the center of sprocket hole and lead stopper	H0	18.0	±0.5	
Total height of resonator	H1	26.5 max.	-	13.01 to 14.99MHz : 27.5 max.
Diameter of sprocket hole	D0	ø4.0	±0.2	
Total tape thickness	t	0.6	±0.2	
Body tilt	ΔS	0	±1.0	

(in mm)

Continued on the following page. ↗

## MHz Lead Type CSTLA/CSTLS Series Packaging

Continued from the preceding page.

### ■ Tape Dimensions of CSTLS\_X

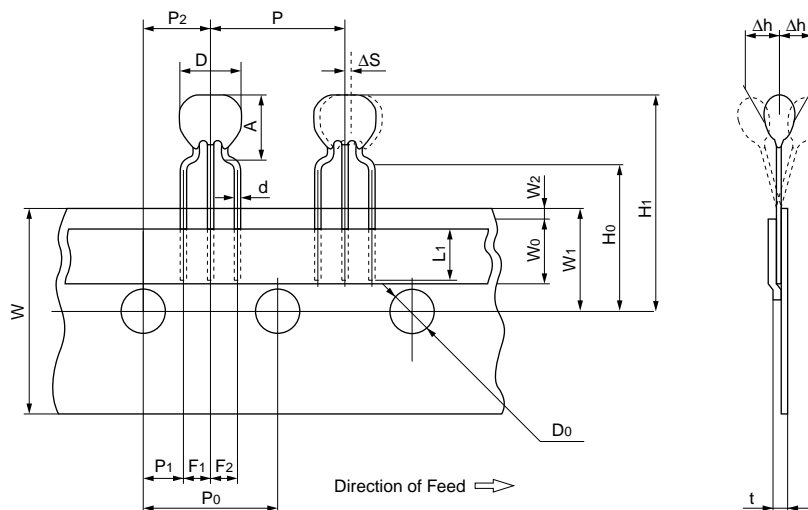

Item	Code	Dimensions	Tolerance	Remarks
Width of diameter	D	5.5	±1.0	
Height of resonator	A	6.5	±0.5	
Dimensions of terminal	d	ø0.48	±0.05	
Lead length under the hold down tape	L1	5.0 min.	—	
Pitch of component	P	12.7	±0.5	Tolerance for Pitches 10xP0=127±1
Pitch of sprocket hole	P0	12.7	±0.2	
Length from sprocket hole center to lead	P1	3.85	±0.5	
Length from sprocket hole center to component center	P2	6.35	±0.5	
Lead spacing (I)	F1	2.5	±0.2	
Lead spacing (II)	F2	2.5	±0.2	
Slant to the forward or backward	Δh	0	±1.0	1mm max.
Width of carrier tape	W	18.0	±0.5	
Width of hold down tape	W0	6.0 min.	—	Hold down tape doesn't exceed the carrier tape.
Position of sprocket hole	W1	9.0	±0.5	
Gap of hold down tape and carrier tape	W2	0	+0.5 -0.0	
Distance between the center of sprocket hole and lead stopper	H0	18.0	±0.5	
Total height of resonator	H1	24.5	±0.1	
Diameter of sprocket hole	D0	ø4.0	±0.2	
Total tape thickness	t	0.6	±0.2	
Body tilt	ΔS	0	±1.0	

(in mm)

Continued on the following page. ↗

# MHz Lead Type CSTLA/CSTLS Series Packaging

Continued from the preceding page.

## ■ Tape Dimensions of CSTLS\_G (2.00 to 3.39MHz)

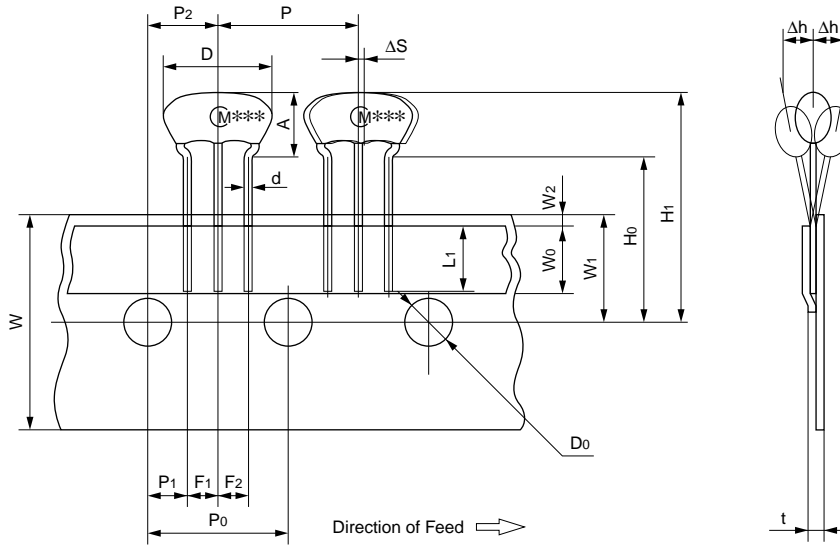

Item	Code	Dimensions	Tolerance	Remarks
Width of diameter	D	9.0	±1.0	
Height of resonator	A	5.5	±0.5	
Dimensions of terminal	d	ø0.48	±0.05	
Lead length under the hold down tape	L <sub>1</sub>	5.0 min.	-	
Pitch of component	P	12.7	±0.5	Tolerance for Pitches 10xP <sub>0</sub> =127±1
Pitch of sprocket hole	P <sub>0</sub>	12.7	±0.2	
Length from sprocket hole center to lead	P <sub>1</sub>	3.85	±0.5	
Length from sprocket hole center to component center	P <sub>2</sub>	6.35	±0.5	
Lead spacing (I)	F <sub>1</sub>	2.5	±0.2	
Lead spacing (II)	F <sub>2</sub>	2.5	±0.2	
Slant to the forward or backward	Δh	0	±1.0	1mm max.
Width of carrier tape	W	18.0	±0.5	
Width of hold down tape	W <sub>0</sub>	6.0 min.	-	Hold down tape doesn't exceed the carrier tape.
Position of sprocket hole	W <sub>1</sub>	9.0	±0.5	
Gap of hold down tape and carrier tape	W <sub>2</sub>	0	+0.5 -0	
Distance between the center of sprocket hole and lead stopper	H <sub>0</sub>	18.0	±0.5	
Total height of resonator	H <sub>1</sub>	23.5	±0.1	
Diameter of sprocket hole	D <sub>0</sub>	ø4.0	±0.2	
Total tape thickness	t	0.6	±0.2	
Body tilt	ΔS	0	±1.0	

(in mm)

Continued on the following page. ↗

## MHz Lead Type CSTLA/CSTLS Series Packaging

Continued from the preceding page.

### ■ Tape Dimensions of CSTLS\_G (3.40 to 10.00MHz)

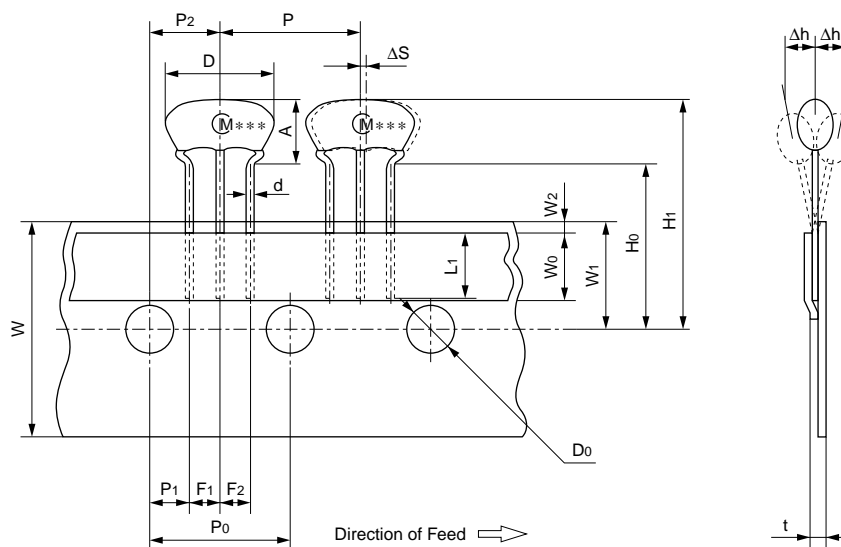

Item	Code	Dimensions	Tolerance	Remarks
Width of diameter	D	8.0	±1.0	
Height of resonator	A	5.5	±0.5	
Dimensions of terminal	d	ø0.48	±0.05	
Lead length under the hold down tape	L1	5.0 min.	—	
Pitch of component	P	12.7	±0.5	Tolerance for Pitches 10xP0=127±1
Pitch of sprocket hole	P0	12.7	±0.2	
Length from sprocket hole center to lead	P1	3.85	±0.5	
Length from sprocket hole center to component center	P2	6.35	±0.5	
Lead spacing (I)	F1	2.5	±0.2	
Lead spacing (II)	F2	2.5	±0.2	
Slant to the forward or backward	Δh	0	±1.0	1mm max.
Width of carrier tape	W	18.0	±0.5	
Width of hold down tape	W0	6.0 min.	—	Hold down tape does not exceed the carrier tape.
Position of sprocket hole	W1	9.0	±0.5	
Gap of hold down tape and carrier tape	W2	0	+0.5 -0	
Distance between the center of sprocket hole and lead stopper	H0	18.0	±0.5	
Total height of resonator	H1	23.5	±1.0	
Diameter of sprocket hole	D0	ø4.0	±0.2	
Total tape thickness	t	0.6	±0.2	
Body tilt	ΔS	0	±1.0	

(in mm)

## MHz Lead Type CSALA/CSALS Series Packaging

### ■ CSALA/CSALS Series Minimum Quantity

Part Number	Ammo Pack	Bulk
CSALA_T (10.01 to 13.00MHz)	1,500	500
CSALA_X (13.01 to 15.99MHz)	1,500	500
CSALS_X (16.00 to 70.00MHz)	2,000	500

The order quantity should be an integral multiple of the "Minimum Quantity" shown above.

(pcs.)

### ■ Tape Dimensions of CSALA

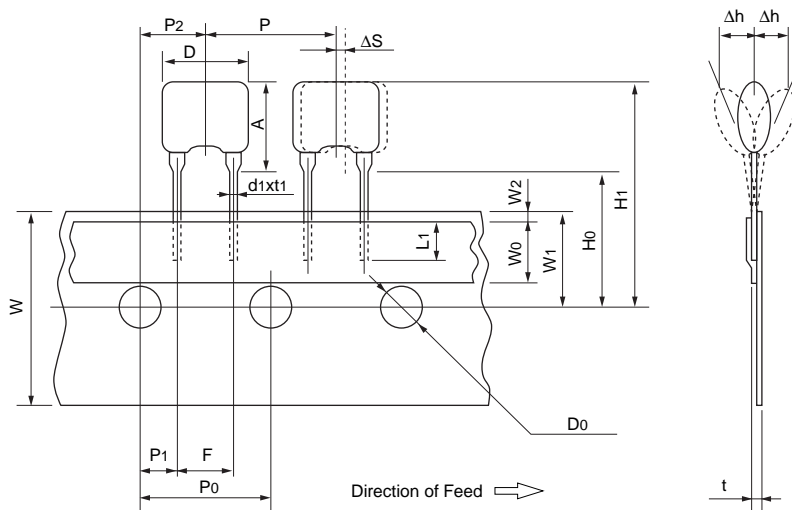

Item	Code	Dimensions	Tolerance	Remarks
Width of diameter	D	10.0 max.		
Height of resonator	A	10.0 max.		
Dimensions of terminal	d1 x t1	0.5 x 0.3	±0.1	
Lead length under the hole down tape	L1	3.0 min.		
Pitch of component	P	12.7	±0.5	Tolerance for pitches 10 x P0=127±1
Pitch of sprocket	P0	12.7	±0.2	
Length from hole center to lead	P1	3.85	±0.5	
Length from hole center to component center	P2	6.35	±0.5	
Lead spacing	F	5.0	+0.5 -0.2	
Slant to the forward or backward	$\Delta h$	0	±1.0	1mm max.
Width of carrier tape	W	18.0	±0.5	
Width of hold down tape	W0	6.0 min.		Hold down tape does not exceed the carrier tape
Position of sprocket hole	W1	9.0	±0.5	
Gap of hold down tape and carrier tape	W2	0	+0.5 -0	
Distance between the center of sprocket hole and lead stopper	H0	18.0	±0.5	
Total height of resonator	H1	28.5 max.		
Diameter of sprocket hole	D0	ø4.0	±0.2	
Total thickness of tape	t	0.6	±0.2	
Body tilt	DS	0	±1.0	

(in mm)

Continued on the following page.

## MHz Lead Type CSALA/CSALS Series Packaging

Continued from the preceding page.

### ■ Tape Dimensions of CSALS

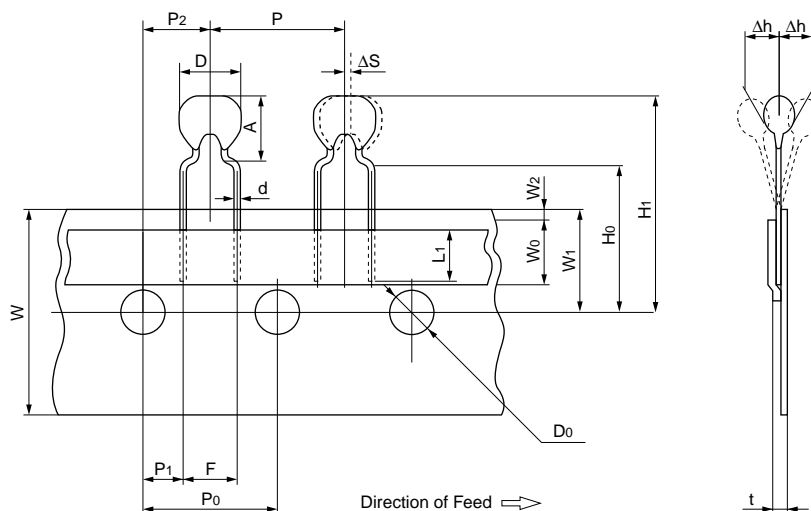

Item	Code	Dimensions	Tolerance	Remarks
Width of diameter	D	5.5	±1.0	
Height of resonator	A	6.5	±0.5	
Dimensions of terminal	d	ø0.48	±0.05	
Lead length under the hold down tape	L1	5.0 min.		
Pitch of component	P	12.7	±0.5	
Pitch of sprocket hole	P0	12.7	±0.2	Tolerance for Pitches 10xP0=127±1
Length from sprocket hole center to lead	P1	3.85	±0.5	
Length from sprocket hole center to component center	P2	6.35	±0.5	
Lead spacing	F	5.0	±0.3	
Slant to the forward or backward	Δh	0	±1.0	1mm max.
Width of carrier tape	W	18.0	±0.5	
Width of hold down tape	W0	6.0 min.		Hold down tape doesn't exceed the carrier tape.
Position of sprocket hole	W1	9.0	±0.5	
Gap of hold down tape and carrier tape	W2	0	+0.5 -0.0	
Distance between the center of sprocket hole and lead stopper	H0	18.0	±0.5	
Total height of resonator	H1	24.5	±1.0	
Diameter of sprocket hole	Do	ø4.0	±0.2	
Total tape thickness	t	0.6	±0.2	
Body tilt	ΔS	0	±1.0	

(in mm)

# Ceramic Resonators(CERALOCK®)



## Chip Type Two-Terminals CSBFB Series

Can be reflow soldered and mounted by automatic placers.  
 MURATA's original package technologies have enabled the development of the kHz band "CERALOCK".  
 The series is perfect in miniature remote control units and AV modules.

### ■ Features

1. The series withstands reflow soldering.
2. The series is mountable by automatic placers.
3. No adjustment is necessary for oscillation circuits.

### ■ Applications

- Clock oscillators for microprocessors.
- OA equipment.
- AV modules.



CSBFB\_J  
430-519kHz

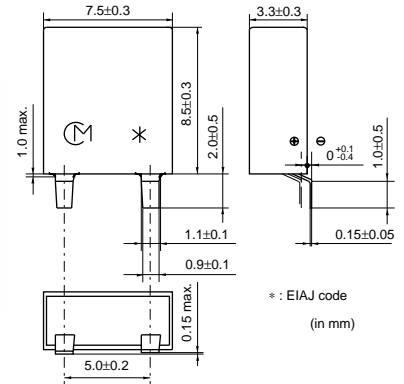

CSBFB\_J  
700-1250kHz

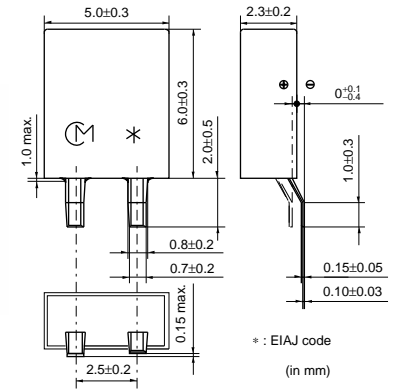

5

Part Number	Oscillating Frequency (kHz)	Initial Tolerance (%)	Temp.Stability (%)	Temperature Range (°C)	Aging (10 years) (%)	Use
CSBFB_J	430 to 519, 700 to 1250	±0.5	±0.3	-20 to 80	±0.3	-

Irregular or stop oscillation may occur under unmatched circuit conditions. Please check the actual conditions prior to use.

### ■ Oscillation Frequency Measuring Circuit

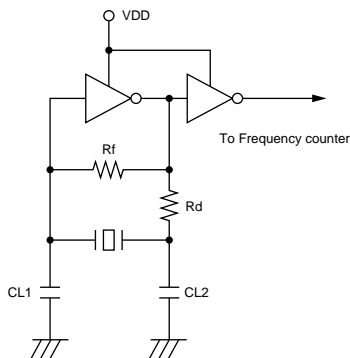

### ■ Oscillation Frequency Temperature Stability

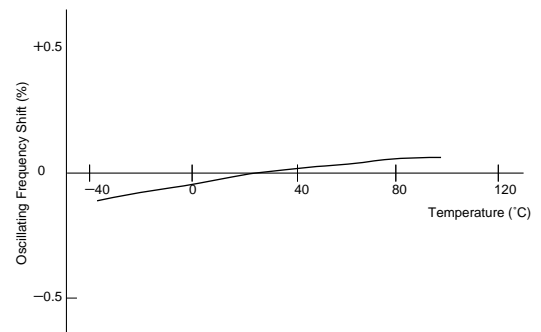

Continued on the following page.

Continued from the preceding page.

### Standard Land Pattern Dimensions

CSBFB\_J (430-519kHz)

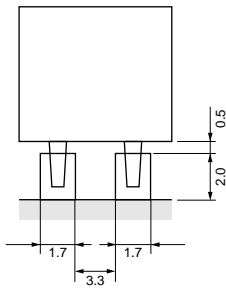

(in mm)

CSBFB\_J (700-1250kHz)

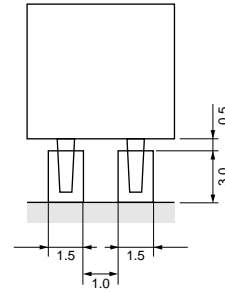

(in mm)

## CSBFB\_J 430-519kHz Notice (Soldering and Mounting)

### 1. Soldering Condition

#### (1) Reflow

Right profile of heat stress is applied to resonator, then being place in natural condition for 1 hour, resonator shall be measured.

1. Pre-heating conditions shall be +140 to +160°C for 60 to 120 seconds. Ascending time up to +150°C shall be longer than 30 second.
2. Heating conditions shall be within 20 seconds at +225°C min., but peak temperature shall be lower than +235°C.

#### (2) Soldering Iron

Soldering iron of +270±5°C shall be placed 0.5mm above from electrode of resonator. Melting solder through soldering iron shall be applied to electrode for 3±1 seconds, then being place in natural condition for 24 hour, resonator shall be measured.

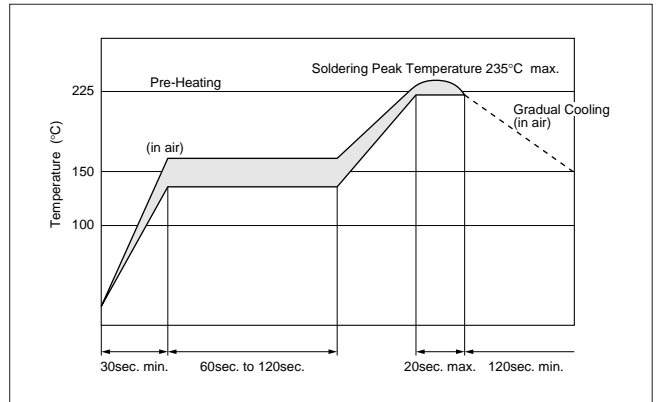

### 2. Wash

#### (1) Cleaning Solvent

HCFC, Isopropanol, Tap water, Demineralized water, Cleanthrough750H, Pine alpha 100S, Techno care FRW

#### (2) Temperature Difference : $\Delta T *1$

$\Delta T \leq 60^\circ\text{C}$  ( $\Delta T = \text{Component} - \text{solvent}$ )

\*1 ex. In case the component at +90°C immerses into cleaning solvent at +60°C, then  $\Delta T = 30^\circ\text{C}$ .

#### (3) Condition

##### 1. Ultrasonic Wash

1 minute max. in above solvent at +60°C max.  
(Frequency : 28kHz, Output : 20W/L)

##### 2. Immersion Wash

5 minutes max. in above solvent at +60°C max.

##### 3. Shower or Rinse Wash

5 minutes max. in above solvent at +60°C max.

#### (4) Drying

5 minutes max. by air blow at +80°C max.

#### (5) Others

1. Total washing time should be within 10 minutes.
2. Please insure the component is thoroughly evaluated in your application circuit.
3. The component may be damaged if it is washed with chlorine, petroleum, or alkali cleaning solvent.

5

# CSFBF\_J 700-1250kHz Notice (Soldering and Mounting)

## 1. Soldering Condition

### (1) Reflow

Right profile of heat stress is applied to resonator, then being place in natural condition for 1 hour, resonator shall be measured.

1. Pre-heating conditions shall be +140 to +160°C for 60 to 120 seconds. Ascending time up to +150°C shall be longer than 30 second.
2. Heating conditions shall be within 20 seconds at +215°C min., but peak temperature shall be lower than +225°C.

### (2) Soldering Iron

Soldering iron of +270±5°C shall be placed 0.5mm above from electrode of resonator. Melting solder through soldering iron shall be applied to electrode for 3±1 seconds, then being place in natural condition for 24 hour, resonator shall be measured.

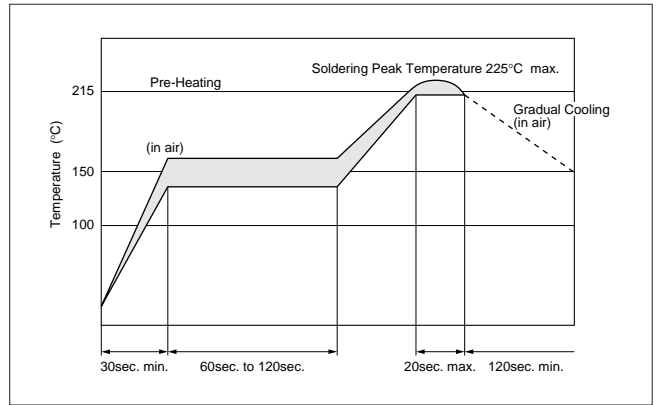

## 2. Wash

### (1) Cleaning Solvent

HCFC, Isopropanol, Tap water, Demineralized water, Cleanthrough750H, Pine alpha 100S, Techno care FRW

### (2) Temperature Difference : $\Delta T *1$

$\Delta T \leq 60^\circ\text{C}$  ( $\Delta T = \text{Component} - \text{solvent}$ )

\*1 ex. In case the component at +90°C immerses into cleaning solvent at +60°C, then  $\Delta T = 30^\circ\text{C}$ .

### (3) Condition

#### 1. Ultrasonic Wash

1 minute max. in above solvent at +60°C max.  
(Frequency : 28kHz, Output : 20W/L)

#### 2. Immersion Wash

5 minutes max. in above solvent at +60°C max.

#### 3. Shower or Rinse Wash

5 minutes max. in above solvent at +60°C max.

### (4) Drying

5 minutes max. by air blow at +80°C max.

### (5) Others

1. Total washing time should be within 10 minutes.
2. Please insure the component is thoroughly evaluated in your application circuit.
3. The component may be damaged if it is washed with chlorine, petroleum, or alkali cleaning solvent.

# Ceramic Resonators(CERALOCK®)



## Lead Type Two-Terminals CSBLA Series

"CERALOCK" with two leaded terminals.  
 The CSALA and CSBLA series ceramic resonator owe their development to MURATA's innovative expert technologies and the application of mass production techniques typically utilized in the manufacture of piezoelectric ceramic components. Because of their high mechanical Q and consistent high quality, both the CSALA and CSBLA series are ideally suited to microprocessor and remote control unit applications. The CSBLA series includes the thin and compact J type which is ideal in high-speed 4-bit microprocessor applications.  
 In addition, MURATA offers a special "CERALOCK" version suitable for automatic insertion utilizing tape and reel and other packaging forms. For further information, please contact your local MURATA representative office or authorized distributor.

### ■ Features

1. The series is stable over a wide temperature range and with respect to long-term aging.
2. The series comprises fixed, tuned, solid-state devices.
3. The resonators are miniature and light weight.
4. They exhibit excellent shock resistance performance.
5. Oscillating circuits requiring no adjustment can be designed by utilizing these resonators in conjunction with transistors or appropriate ICs.

### ■ Applications

- Square-wave and sine-wave oscillator.
- Clock generator for microprocessors.
- Remote control systems.

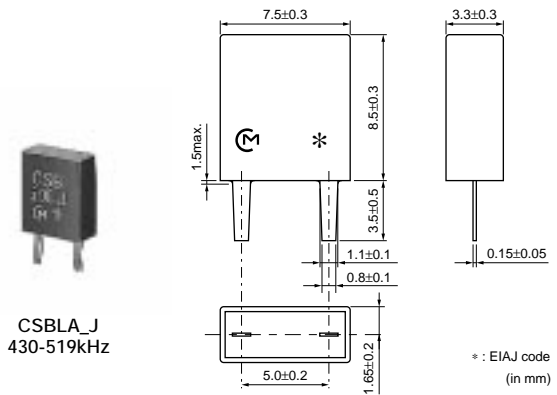
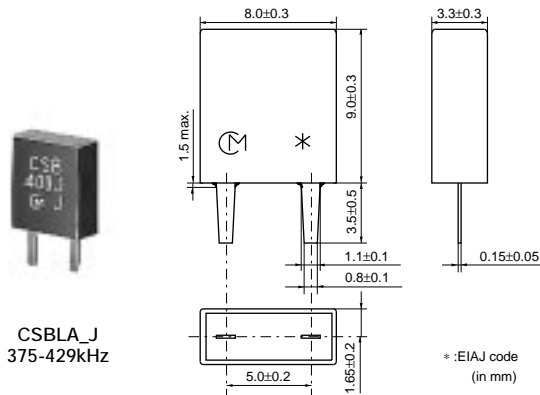
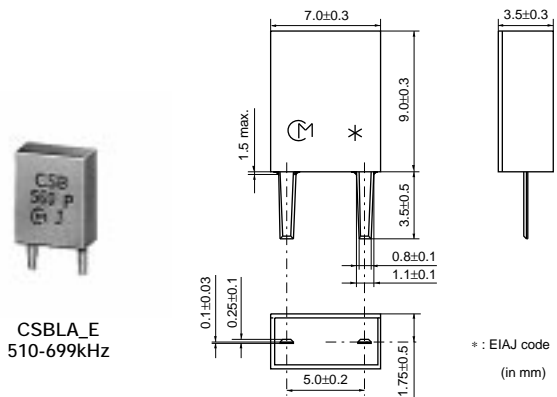
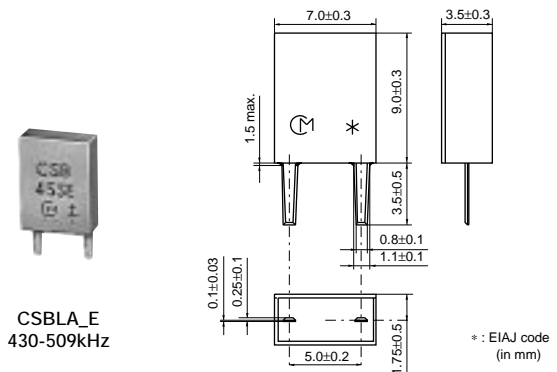
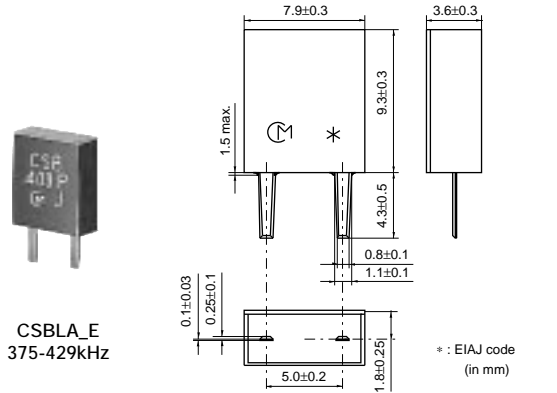

Continued on the following page. ↗

Continued from the preceding page.

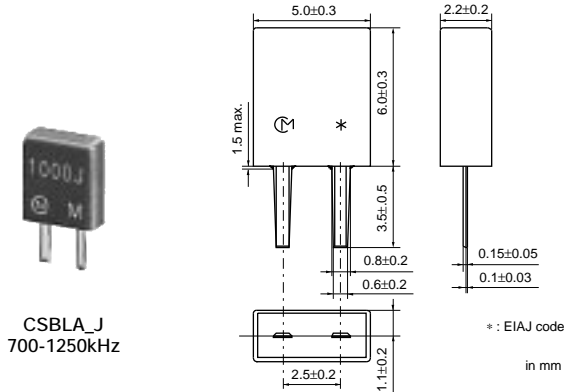
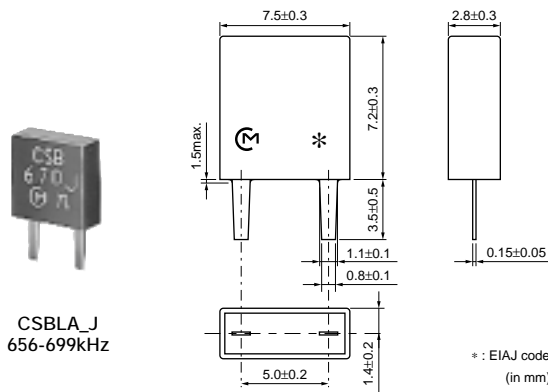
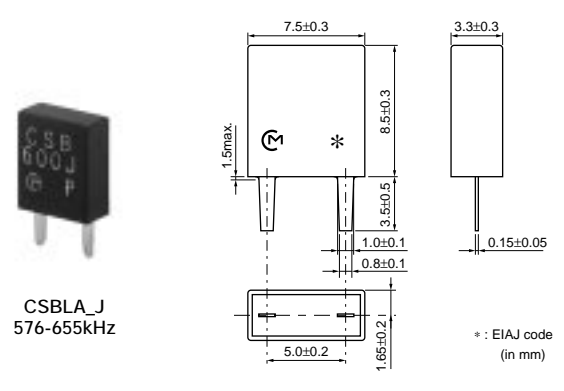
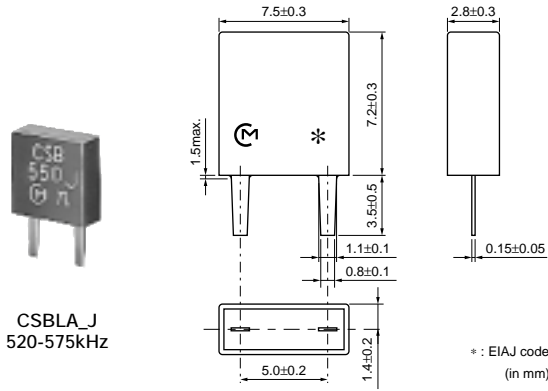

Part Number	Oscillating Frequency (kHz)	Initial Tolerance	Temp. Stability (%)	Temperature Range (°C)	Aging (10 years) (%)	Use
CSBLA_E	375 to 429, 510 to 699	±2kHz	±0.3	-20 to 80	±0.3	-
CSBLA_E	430 to 509	±2kHz	±0.3	-20 to 80	±0.3	-
CSBLA_J	375 to 575, 656 to 1250	±0.5%	±0.3	-20 to 80	±0.3	-
CSBLA_J	576 to 655	±0.5%	±0.3	-20 to 80	±0.3	-

Irregular or stop oscillation may occur under unmatched circuit conditions. Please check the actual conditions prior to use.  
The order quantity should be an integral multiple of the Minimum Quantity shown in the packaging page.

### ■ Oscillation Frequency Measuring Circuit

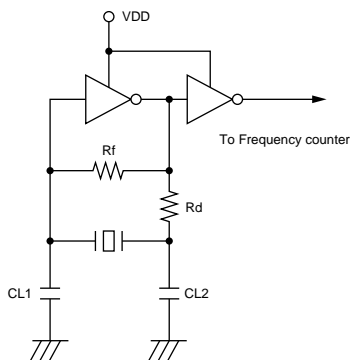

### ■ Oscillation Frequency Temperature Stability

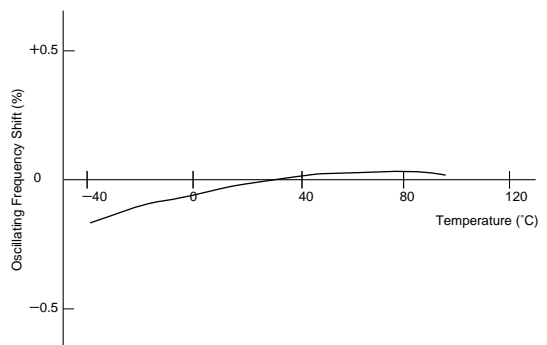

## CSBLA Series Notice(Soldering and Mounting)

### ■ Notice (Soldering and Mounting)

CSBLA\_E

The component cannot be withstand washing.

### ■ Notice (Soldering and Mounting)

CSBLA\_J

#### (1)Cleaning Solvent

HCFC, Isopropanol, Tap water, Demineralized water,  
Cleanthrough750H, Pine alpha 100S, Techno care FRW

#### (2)Temperature Difference: $\Delta T$ \*1

$\Delta T \leq 30^{\circ}\text{C}$  ( $\Delta T = \text{Component} - \text{solvent}$ )

\*1 ex. In case the component at  $+90^{\circ}\text{C}$  immerses into  
cleaning solvent at  $+60^{\circ}\text{C}$ , then  $\Delta T = 30^{\circ}\text{C}$ .

#### (3)Condition

##### 1. Ultrasonic Wash

1 minute max. in above solvent at  $+60^{\circ}\text{C}$  max.

(Frequency:28kHz, Output:20W/L)

##### 2. Immersion Wash

5 minutes max. in above solvent at  $+60^{\circ}\text{C}$  max.

##### 3. Shower or Rinse Wash

5 minutes max. in above solvent at  $+60^{\circ}\text{C}$  max.

#### (4)Drying

5 minutes max. by air blow at  $+80^{\circ}\text{C}$  max.

#### (5)Others

1. Total washing time should be within 10 minutes.

2. Please insure the component is thoroughly  
evaluated in your application circuit.

3. The component may be damaged if it is washed with  
alkali cleaning solvent.

## kHz CSBFB/CSBLA Series Notice

### ■ Notice (storage and operating condition)

#### CSBFB\_J

Please do not apply excess mechanical stress to the component and lead terminals at soldering.

Conformal coating of the component is acceptable.

However, the resin material, curing temperature, and other process conditions should be evaluated to confirm stable electrical characteristics are maintained.

Ultrasonic cleaning of the component is acceptable.

However, the size of bath, size and thickness of PBC should be evaluated to confirm stable electrical characteristics are maintained.

In case of the bulk component, dry heating treatment (130 C. for 5 hours min.) is required before reflow soldering. Then, the component should be soldering within 48 hours after dry heating treatment.

### ■ Notice (storage and operating condition)

#### CSBLA\_E

Please do not apply excess mechanical stress to the component and lead terminals at soldering.

Conformal coating or washing to the component is not acceptable. Because it is not hermetically sealed.

### ■ Notice (storage and operating condition)

#### CSBLA\_J

Please do not apply excess mechanical stress to the component and lead terminals at soldering.

Conformal coating of the component is acceptable.

However, the resin material, curing temperature, and other process conditions should be evaluated to confirm stable electrical characteristics are maintained.

Ultrasonic cleaning of the component is acceptable.

However, the size of bath, size and thickness of PBC should be evaluated to confirm stable electrical characteristics are maintained.

### ■ Notice (Rating)

The component may be damaged if excess mechanical stress is applied.

### ■ Notice (Handling)

"CERLOCK" may stop oscillating or oscillate irregularly under improper circuit conditions.

## kHz CSBFB/CSBLA Series Packaging

### CSBFB Series Minimum Quantity

Part Number	Plastic Tape ø330mm	Bulk
CSBFB_J (430 to 519kHz)	1,500	500
CSBFB_J (700 to 1250kHz)	3,000	1,000

The order quantity should be an integral multiple of the "Minimum Quantity" shown above.

(pcs.)

### Dimensions of Reel

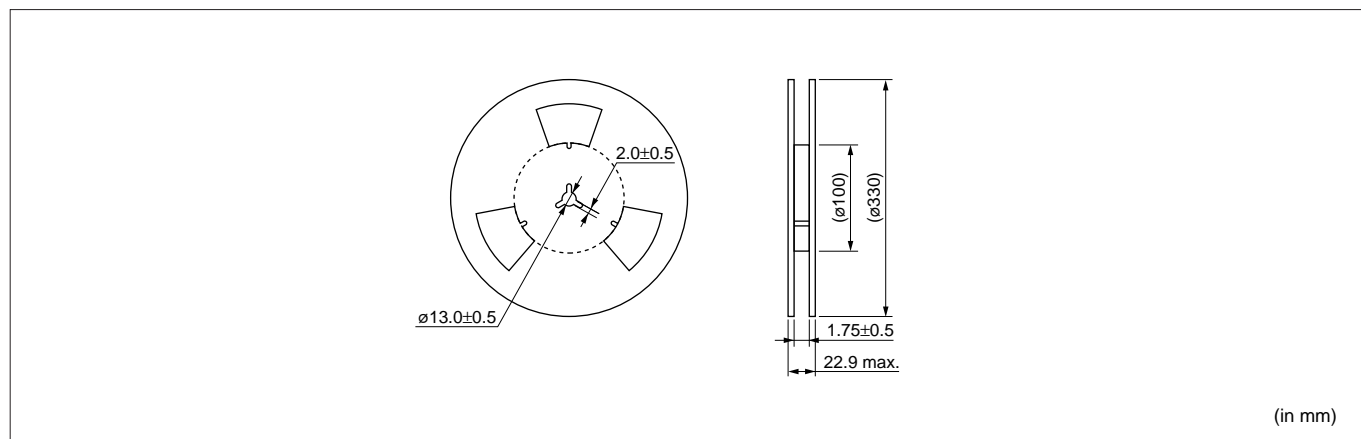

(in mm)

### CSBFB\_J (430-519kHz)

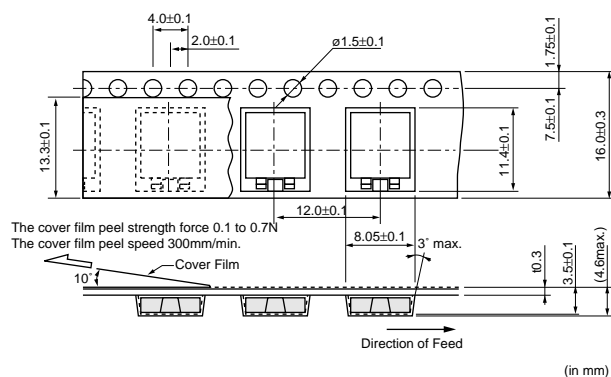

(in mm)

### CSBFB\_J (700-1250kHz)

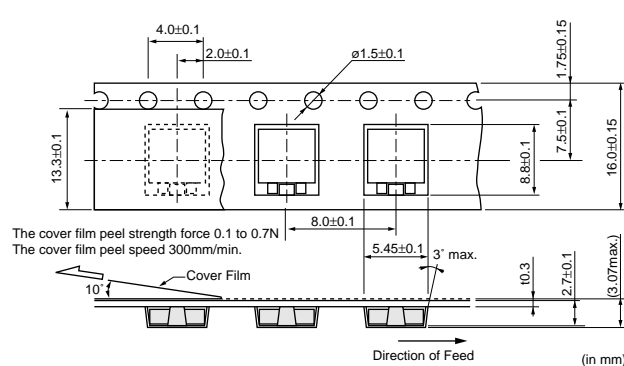

(in mm)

### CSBLA Series Minimum Quantity

Part Number	Magazine	Bulk
CSBLA_E	50	500
CSBLA_J (375 to 699kHz)	50	500
CSBLA_J (700 to 1250kHz)	100	1,000

The order quantity should be an integral multiple of the "Minimum Quantity" shown above.

(pcs.)

## Application Circuits Utilizing

### ■ TMP87CM40AN(TOSHIBA)

8-bit Microcomputer

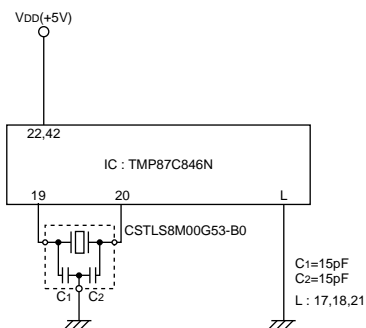

### ■ MC68HC908JB8(MOTOROLA)

8-bit Microcomputer

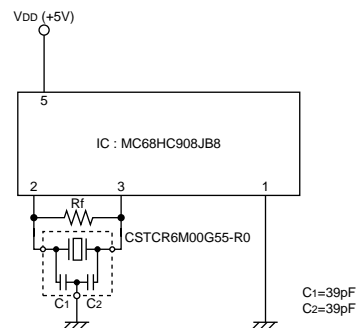

### ■ uPD78018F(NEC)

8-bit Microcomputer

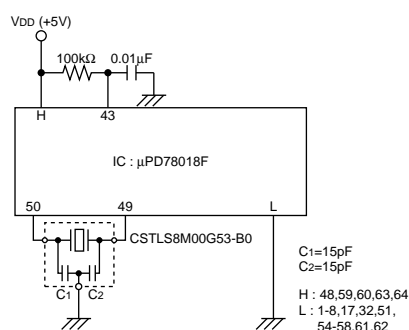

### ■ HD64F3337(HITACHI)

8-bit Microcomputer

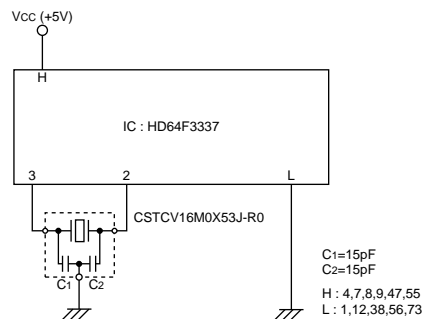

### ■ ML66517(OKI)

8-bit Microcomputer

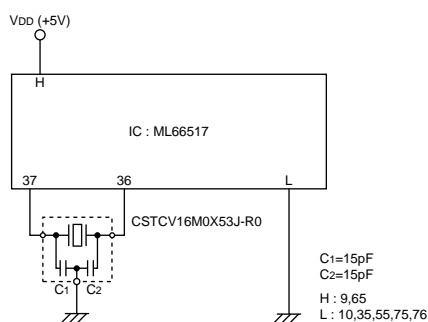

### ■ M38039MF(MITSUBISHI)

8-bit Microcomputer

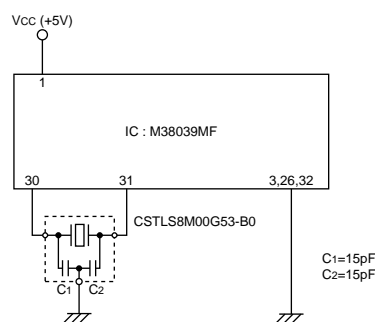

Continued on the following page.

## Application Circuits Utilizing

Continued from the preceding page.

### ■ M34280M1(MITSUBISHI)

Remote Control Unit

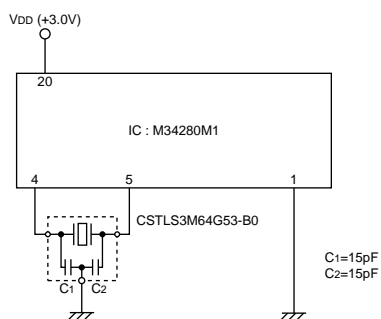

### ■ uPD65(NEC)

Speech Synthesizer

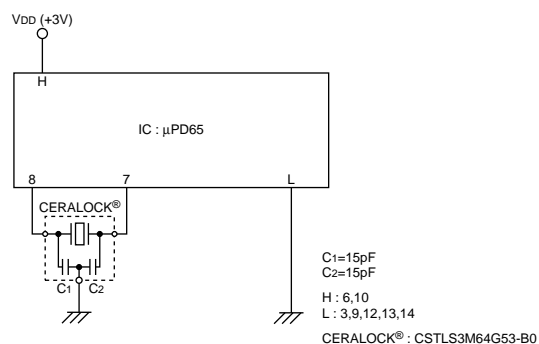

### ■ uPD754304(NEC)

4-bit Microcomputer

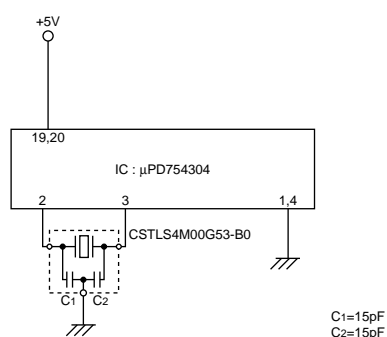

### ■ LC651154F(SANYO)

4-bit Microcomputer

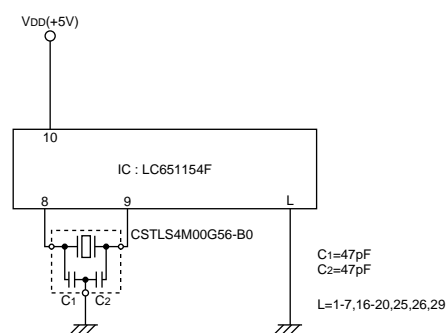

### ■ LC7367JM(SANYO)

Tone/Pulse Dialer

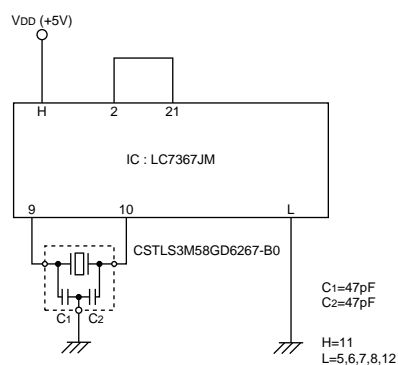

### ■ ML7005MB(OKI)

Tone/Pulse Dialer

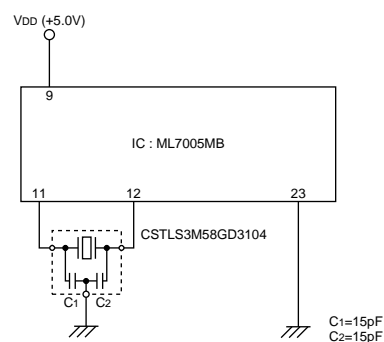

Continued on the following page.

## Application Circuits Utilizing

Continued from the preceding page.

### ■ uPD70F3102GJ(NEC)

32-bit Microcomputer

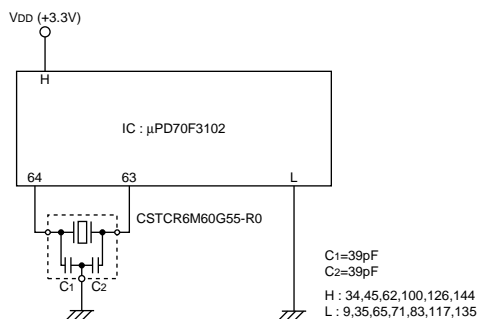

### ■ CXD2598Q(SONY)

Digital Signal Processing IC for CD

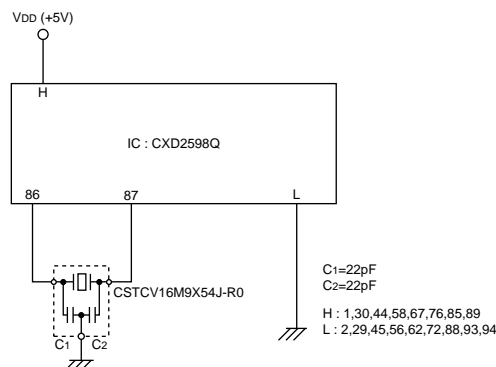

### ■ LC895299(SANYO)

Error Correction of CD-ROM LSI

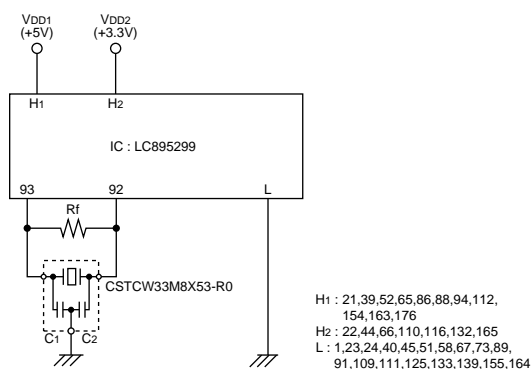

### ■ TMP47C660AN(TOSHIBA)

4-bit Microcomputer

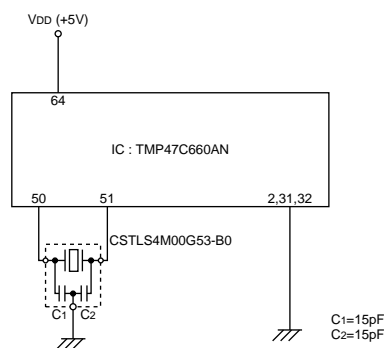

### ■ TA8690AN(TOSHIBA)

TV Horizontal/Compatible with Synthesizer Circuit

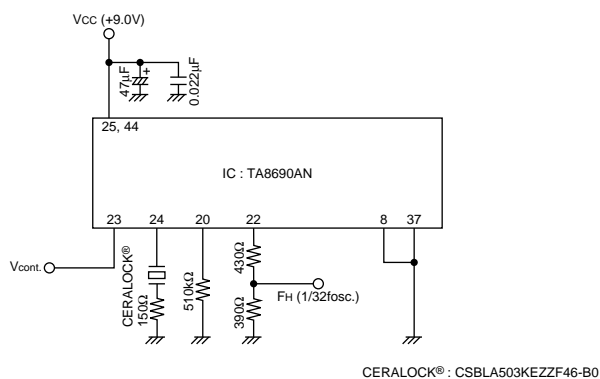

### ■ LA3410(SANYO)

FM Stereo MPX

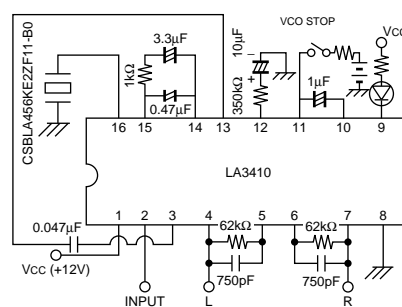

Continued on the following page.

## Application Circuits Utilizing

Continued from the preceding page.

### ■ TEA2130(THOMSON)

TV Horizontal/Compatible with Synthesizer Circuit

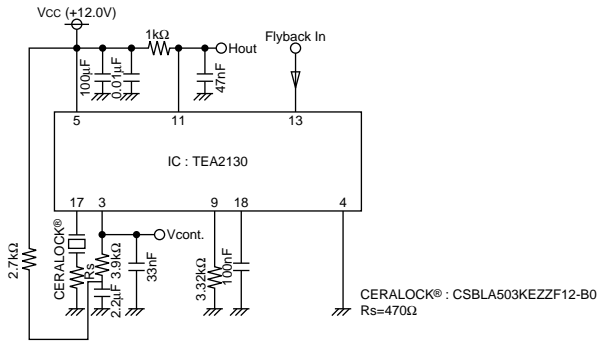

### ■ LA7687(SANYO)

TV Horizontal/Compatible with Synthesizer Circuit

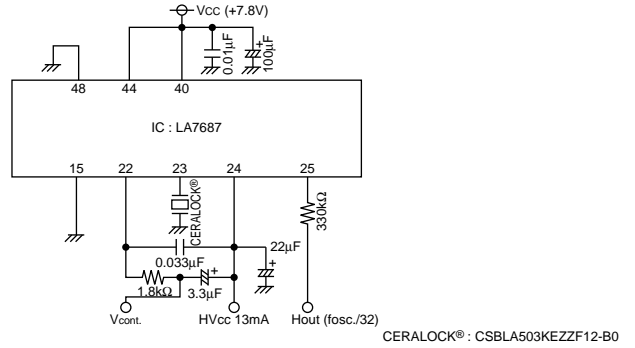

### ■ Oscillation Circuit Incorporating Transistor

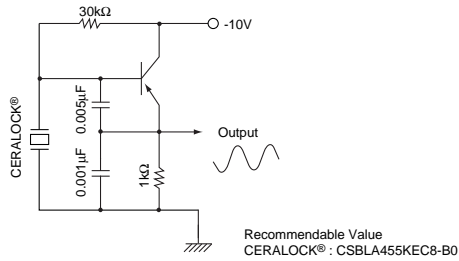

**⚠ Note:**

1. Export Control

⟨For customers outside Japan⟩

Murata products should not be used or sold for use in the development, production, stockpiling or utilization of any conventional weapons or mass-destructive weapons (nuclear weapons, chemical or biological weapons, or missiles), or any other weapons.

⟨For customers in Japan⟩

For products which are controlled items subject to the "Foreign Exchange and Foreign Trade Law" of Japan, the export license specified by the law is required for export.

2. Please contact our sales representatives or product engineers before using our products listed in this catalog for the applications listed below which require especially high reliability for the prevention of defects which might directly cause damage to the third party's life, body or property, or when intending to use one of our products for other applications than specified in this catalog.

- ① Aircraft equipment
- ② Aerospace equipment
- ③ Undersea equipment
- ④ Power plant equipment
- ⑤ Medical equipment
- ⑥ Transportation equipment (vehicles, trains, ships, etc.)
- ⑦ Traffic signal equipment
- ⑧ Disaster prevention / crime prevention equipment
- ⑨ Data-processing equipment
- ⑩ Application of similar complexity and/or reliability requirements to the applications listed in the above

3. Product specifications in this catalog are as of April 2001. They are subject to change or our products in it may be discontinued without advance notice. Please check with our sales representatives or product engineers before your ordering. If there are any questions, please contact our sales representatives or product engineers.

4. Please read CAUTION and Notice in this catalog for safety. This catalog has only typical specifications. Therefore you are requested to approve our product specification or to transact the approval sheet for product specification, before your ordering.

5. Please note that unless otherwise specified, we shall assume no responsibility whatsoever for any conflict or dispute that may occur in connection with the effect of our and/or third party's intellectual property rights and other related rights in consideration of your using our products and/or information described or contained in our catalogs. In this connection, no representation shall be made to the effect that any third parties are authorized to use the rights mentioned above under licenses without our consent.

6. None of ozone depleting substances (ODS) under the Montreal Protocol is used in manufacturing process of us.